

Technical University of Denmark



## The Pan-European Reference Grid Developed in the ELECTRA Project for Deriving Innovative Observability Concepts in the Web-of-Cells Framework

**Marinelli, Mattia; Pertl, Michael; Rezkalla, Michel M.N.; Kosmecki, Michal; Canevese, Silvia; Obushevs, Artjoms; Morch, Andrei Z.**

*Published in:*

Proceedings of the 51st International Universities Power Engineering Conference (UPEC)

*Publication date:*

2016

*Document Version*

Peer reviewed version

[Link back to DTU Orbit](#)

*Citation (APA):*

Marinelli, M., Pertl, M., Rezkalla, M. M. N., Kosmecki, M., Canevese, S., Obushevs, A., & Morch, A. Z. (2016). The Pan-European Reference Grid Developed in the ELECTRA Project for Deriving Innovative Observability Concepts in the Web-of-Cells Framework. In Proceedings of the 51st International Universities Power Engineering Conference (UPEC) IEEE.

## DTU Library

Technical Information Center of Denmark

---

### General rights

Copyright and moral rights for the publications made accessible in the public portal are retained by the authors and/or other copyright owners and it is a condition of accessing publications that users recognise and abide by the legal requirements associated with these rights.

- Users may download and print one copy of any publication from the public portal for the purpose of private study or research.
- You may not further distribute the material or use it for any profit-making activity or commercial gain
- You may freely distribute the URL identifying the publication in the public portal

If you believe that this document breaches copyright please contact us providing details, and we will remove access to the work immediately and investigate your claim.

# The Pan-European Reference Grid Developed in ELECTRA for Deriving Innovative Observability Concepts in the Web-of-Cells Framework

Mattia Marinelli<sup>1</sup>, Michael Pertl<sup>1</sup>, Michel Rezkalla<sup>1</sup>,  
Michal Kosmecki<sup>2</sup>, Silvia Canevese<sup>3</sup>, Artjoms Obushevs<sup>4</sup>, Andrei Morch<sup>5</sup>

<sup>1</sup>Center for Electric Power and Energy, Department of Electrical Engineering, DTU - Technical University of Denmark

<sup>2</sup>Institute of Power Engineering, Gdańsk, Poland

<sup>3</sup>Ricerca sul Sistema Energetico - RSE, Milano, Italy

<sup>4</sup>Institute of Physical Energetics, Smart Grid Research Centre, Riga, Latvia

<sup>5</sup>Department of Energy Systems, SINTEF Energy Research, Trondheim, Norway

**Abstract**— In the ELECTRA EU project, an innovative approach for frequency and voltage control is investigated, with reference to future power system scenarios characterized by massive amounts of distributed energy resources. A control architecture based on dividing the power system into a web of subsystems, the so-called cells, is proposed. Cells are individual control entities but also need to be coordinated together at system-wide level, in order to ensure secure and reliable overall operation (at Pan-European level). Task 5.4 in the ELECTRA project focuses on deriving novel observability concepts at system-wide scale. The methodology proposed in the task analyzes the system performance by investigating typical phenomena peculiar to each stability type and by developing observables necessary for the novel Web-of-Cells based control methods to operate properly at cell- and inter-cell level. Crucial aspects of angle, frequency and voltage stability are considered, according to the stability classification by CIGRÉ. In order to carry out the evaluations, a suitable test multi-cell grid model is developed. The paper aims at describing this reference model and at presenting the approach used in the task for assessing system stability in the developed WoC framework.

**Index Terms**—HVDC transmission, Power system stability; Power system modeling; Reference grid.

## I. INTRODUCTION

A considerable amount of research efforts is put nowadays to investigate various aspects needed to allow for a shift from a traditional power system, where frequency and voltages are controlled by a relatively small set of very large units, to a futuristic system, where potentially all power devices can be involved in the controlling actions, in order to accommodate massive amounts of (mainly small-scale) distributed energy resources.

In the ELECTRA project, in particular, innovative control schemes are being investigated in order to assess whether conventional frequency and voltage controlling approaches are still suitable, or which aspects need to be revised for the considered future scenarios [1], [2]. Adequate observability of the power system's operating state is notably becoming a more and more urgent requirement for a reliable and secure supply of electricity. Suitable subsets of observables are the

starting point for control design [3]-[5]. On the whole, the approach adopted in ELECTRA to deal with power system control is based on a web of subsystems, called cells, which are operated by Cell Operators (CO), entities similar to present TSOs. For control purposes, a CO has to act on the inner resources of its own cell and can also cooperate with other COs, in particular with the neighbouring cells COs, so that the whole power system, i.e. the whole Web-of-Cells (WoC), is stable and secure [6]. A cell can be defined as a group of interconnected loads, concentrated generation plants and/or distributed energy resources and storage units, all within well-defined grid boundaries corresponding to a physical portion of the grid and to a confined geographical area; neighbouring cells are connected by tie lines. A cell may include nodes at different voltage levels (HV, MV, LV).

Based on operational security requirements a cell is in 'normal state' when in real-time operation:

- it is able to follow the scheduled consumption/generation set-point so that the voltage, frequency and power flows are within the operational security limits;
- it is able to activate sufficient flexible ancillary resources (active and reactive power reserves).

A cell needs to aggregate sufficient flexible resources to manage the uncertainty (variability) due to internal generation/load forecasting errors, but in case of need it can reach its balanced condition by interacting with neighbouring cells. A microgrid, instead, needs to aggregate sufficient resources to potentially allow internal generation and load to balance without any external contributions, i.e. to allow for islanded operation.

In order to keep a secure operation of a cell, or a whole WoC, in the normal state, two main control types are needed:

- Balance Control, which includes all control loops (or control actions) that ensure, in real-time operation, the power balance between generation and load;

- Voltage Control, which includes all control loops (or control actions) that ensure, in real-time operation, that voltage at each node remains within operational limits.

Task 5.4 in the ELECTRA project focuses on deriving novel observability concepts at the system-wide scale. The proposed methodology analyses the system performance by investigating typical phenomena peculiar to each stability type (Section II) and by developing observables necessary for the novel WoC-based control methods to operate properly at cell- and inter-cell level [7]. Crucial aspects of angle, frequency and voltage stability will be considered, according to the stability classification by CIGRÉ [8]. In order to carry out the investigation, a suitable reference grid is developed and described in Section III.

## II. TASK METHODOLOGY AND SYSTEM-WIDE TOPICS

The work methodology adopted in the task can be summarized as follows.

A set of relevant topics for analyzing system-wide stability is chosen according to the traditional system stability classification presented in [8] and considering future trends in power system development (e.g. HVDC network expansion) and commercial schedule impact over physical power flows (e.g., loop flows):

- Topic 1: Cell transient stability (large disturbance stability)
- Topic 2: Cell small signal stability with focus on inter-cell oscillation (small disturbance stability)
- Topic 3: Inertia at WoC level (frequency stability)
- Topic 4: Voltage stability (transmission capacity)
- Topic 5: Inter-cell loop flows
- Topic 6: HVDC operation (trip/runback)

For each of the topics analyzed, focus is put, first of all, on the main phenomena involved, along with the solutions used today to face them. In each topic, then, differences between the traditional way of controlling the power system and the proposed way to control a future power system structured as a WoC are pointed out, and summarized in a picture with the structure illustrated in Fig. 1. Detailed results are provided in [7], while an overview of the topics is reported below.

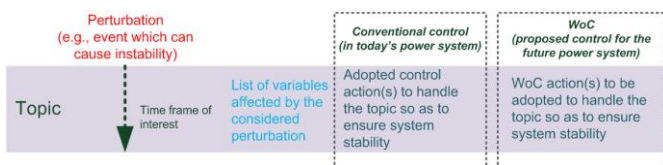

Fig. 1. Support scheme for a detailed comparison between the traditional and the proposed ways to control the power system.

### Topic 1: Cell transient stability (large disturbance stability)

Transient stability is one out of many power system stability aspects with particular focus on the short term, typically 1 - 30 seconds after the incident [9]. Transient stability defines the ability of a power system to maintain synchronism after being subject to a severe transient disturbance such as a three phase fault, loss of generation or loss of a large load (i.e., if the power system is able to move from one state to the next one with system variables

remaining within safe limits). The power system variables like bus voltages, power flows, rotor angles as well as other system variables may deviate greatly from their operational set point values after being subject to a severe disturbance, and depending on the system initial conditions they will/will not reach a steady value after clearance of the disturbance, i.e. if transient stability is given/not given. The nonlinear power system characteristics are highly influencing the stability of the power system itself while transient stability gains special interest when long distance heavy power transmissions are involved. Due to its nonlinear character, fast evolution and catastrophic practical implications, transient stability is one of the most important and at the same time most problematic issues to assess and even more to control.

*Remark:* within a WoC power system control architecture, transient stability has to be assessed (and control actions guaranteeing it have to be designed) with reference both to individual cells and to the whole WoC itself.

### Topic 2: Cell small signal stability

Small signal stability is concerned with the ability of the power system to maintain synchronism under small disturbances (sufficiently small so that linearization of the system equations is permissible for purposes of analysis).

Instability may arise in two forms: increase of rotor angle due to lack of sufficient synchronization torque, or rotor oscillations of increasing amplitude due to lack of sufficient damping torque.

While interconnections result in operating economy and increased reliability through mutual assistance, they contribute to increased complexity of stability problems and increased consequences of instability. With the growth of extensive power systems, and especially with the interconnection of these systems by ties of limited capacity, oscillations can reappear. There are several reasons for this reappearance [10]:

- For inter-area oscillations, the synchronous machine damping circuit is no longer effective, as the damping produced is reduced in approximately inverse proportion to the square of the effective external-impedance-plus-stator-impedance, and so it practically disappears.
- The proliferation of automatic controls has increased the probability of adverse interactions among them.
- Automatic controls are practically the only devices that may produce negative damping; the damping of the uncontrolled system is itself very small and could easily allow the continually changing load and generation to result in undesired tie-line power oscillations.
- A small oscillation in each generator that may be insignificant may add up to a tie-line oscillation that is very significant relative to its rating.
- Higher tie-line loading increases both the tendency to oscillate and the importance of the oscillation.

*Remark:* within a WoC context, small disturbance stability, has to be assessed (and control actions guaranteeing it have to

be designed) with reference to the whole WoC itself, i.e., by analysing inter-cell oscillations.

*Topic 3: Inertia at Pan-European level (frequency stability)*

The energy stored in the power system and instantly available to be exchanged is accounted for mainly by kinetic energy of the connected electric machines (synchronous and asynchronous generators and motors). Inertia is an inherent mechanical feature of rotating masses and it acts as an early intrinsic countermeasure against frequency deviation after perturbations due to load-generation imbalances. More precisely, as it is well known, the *present* structure of the controlled power system response to a sudden change in the active power balance can be divided into five stages [11]-[12], the second of which is indeed the Inertial Response (IR):

- First of all, the magnetic field of synchronous generators releases electromagnetic energy, for about 1/3 s, to contribute to maintaining synchronism.
- After the electromagnetic release, the IR acts, for few seconds at most; IR of synchronous machines is the inherent release of kinetic energy stored in the rotors of the rotating generators.
- Within a few seconds from the event the Primary Frequency Reserve (PFR) is activated, which should be completely deployed by a time interval which in present ENTSO-E requirements is indicated as 30 s from the event; the related control action stabilizes frequency to a steady state which is usually different from the setpoint frequency value, so that a steady deviation with respect to the set point frequency is reached.
- Within (typically, according to the present ENTSO-E requirements) 15 minutes from the event, the secondary control reserve is deployed, to bring frequency back to its nominal value and free up the PFR.
- The secondary control reserve is followed and supported by the tertiary one, which frees up the previous two.

Therefore, when the active power balance in a power system undergoes a large disturbance, both rotor angle and frequency stability have to be considered: in fact, as also highlighted by [12], the former is concerned with keeping synchronism throughout the system, and the latter with keeping the system operating in a tolerable point of frequency equilibrium and with minimal loss of load. Inertia contributes to both “kinds” of stability: in fact, IR is related to the rotor angle change in synchronous machines, so it contributes to rotor angle stability, namely it contributes to keeping this angle within suitable bounds so that synchronism is preserved; it also contributes to frequency stability, because it affects both the Rate Of Change Of Frequency (ROCOF) and the maximal frequency deviation: the former, in turn, influences the behaviour of protective relays (whose action can lead not only to island operation, but also to system blackout), the latter is directly connected to load shedding.

*Remark:* with reference to a WoC system architecture, overall frequency stability can be assessed, e.g., by evaluating the amount of necessary versus the amount of available

physical inertia in each cell and of more or less flexible resources able to supply frequency control actions; then, control actions to achieve it can be designed, e.g. by introducing a possible synthetic inertia contribution (to reduce the absolute ROCOF) from new power-electronics-connected devices or new – and faster than the present PFR – contributions to frequency deviation containment.

*Topic 4: Voltage stability (transmission capacity)*

Typically, voltage stability denotes the ability of a power system to maintain voltages within limits at all its buses under normal operation and after a disturbance. It consists in the ability to maintain equilibrium between load demand and generation supply from the power system, mainly in terms of reactive power. Voltage instability may occur in the form of a progressive fall or rise of voltages of some buses and may contribute to a blackout.

While this definition implies that voltage stability is a global or wide-area issue, it is also among other stability types an important constraint for radial or point-to-point power transfer capability. In this respect, voltage instability is caused by the incapability of the generation and transmission system to deliver the reactive power necessary to satisfy load demand, whilst keeping the voltages in a permissible range. For example, for extra high voltages (EHV) lines longer than 80 km voltage drop starts to dominate as a factor limiting transfer until up to around 300 km, where small signal and transient stability are the most important limiting factors [13]. From this perspective, voltage stability analysis is a significant part of Pan-European system analysis.

In the context of ELECTRA and Pan-European system analysis, the problem of voltage (in)stability can be redefined as a power supply problem specifying the limits of the power that can be supplied to the load and in this way determining stability of the supply or stability of the transfer corridors.

*Topic 5: Inter-cell loop flows*

An inter cell loop flow is a physical phenomenon that occurs when there is a difference between commercial schedules and physical flows of power between the producers and the customers. As shown in Fig. 2 [14], the power transmitted from a producer to a consumer flows through all lines connecting the two, not only along the shortest distance between them.

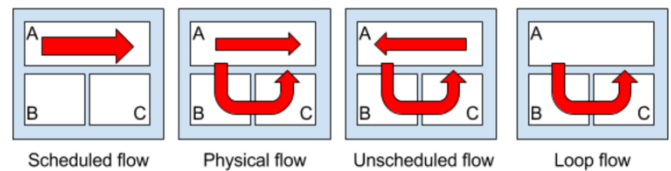

Fig. 2. Terms explaining inter-cell loop flows.

The scheduled flows are defined according to the market solution and describe the contracted import/export between and within the cells in the system. As seen in Fig. 2, some of the power flows through Cell B and Cell C before going back into cell A. The unscheduled flows are the difference between the physical flow and the scheduled flow. Loop flows are the

unscheduled flows through cells, which are not part of the scheduled flow.

Power loop flows occur when a cell does not have enough internal grid infrastructures to handle new production. The power is diverted through neighbouring cells and then back into a different part of the producing cell. This can cause overloading of critical sections of tie-lines, thus impacting on system stability.

#### Topic 6: HVDC operation (trip/runback)

Irrespective of smart-grid development pace and direction, HVDC technology will play an important role in future power system operation, either as a means for power plants (mostly offshore wind power) interconnection, bulk-power transmission corridors, or even as a backbone of a Pan-European transmission system (DC Grid). Constantly increasing power levels and attainable lengths of the HVDC connections result in increasing peril for the secure AC power system operation in case of a disturbance causing a DC link to trip. Power imbalances, e.g., surplus on sending end and shortage on receiving end, can provoke effects similar to those stemming from tripping out aggregated generation or load. In such an event, active power imbalance would most likely be accompanied by reactive power flow change, resulting in further aggravation of voltage problems. Moreover, if the tripped HVDC link was operating between two parts of a synchronous system also connected by other tie lines, these could become overloaded and eventually trip.

Occasionally, when a DC link is a main transmission corridor for power delivery to an islanded power system (e.g. Gotland, Corsica-Sardinia), an abrupt termination of transmission might also cause frequency fluctuations and, depending on the current operating state of the islanded power system, activation of special protection schemes (e.g. UFLS – Under Frequency Load Shedding) in order to restore the power balance. Therefore, from the stability point of view, HVDC malfunction can have impact on almost all stability-related aspects of a power system.

### III. PAN-EUROPEAN REFERENCE GRID

#### A. CIGRÉ European HV Benchmark

The European HV Benchmark network proposed in the CIGRÉ report [15] laid the foundation for the derived Pan-European test grid for ELECTRA Task 5.4, described subsequently. A synthetic overview of the original CIGRÉ grid is reported in Fig. 3.

The network transmission voltages used are 220 kV and 380 kV, which are typical in European transmission systems. Generation bus voltages are 22 kV, and the system frequency is 50 Hz. The system is a balanced three-phase HV transmission network, and assumes ideal line transposition. The HV transmission network benchmark consists of 13 buses and covers three geographical areas, referred to as Areas 1, 2, and 3, denoted by dashed lines. Area 1 is predominantly a generation center. Area 2, situated about 500 km far from Area 1, is a load center with a small amount of generation available. Area 3 is situated between the main

generation Area 1 and the main load center Area 2. Three voltage levels exist in the network: generation bus voltage of 22 kV, primary transmission high voltage of 220 kV, and a long line connecting Areas 1 and 2 at the EHV level of 380 kV. Bus 6a in Area 2 is a suitable location for studying the incorporation of large-scale renewable energy sources such as wind energy conversion systems.

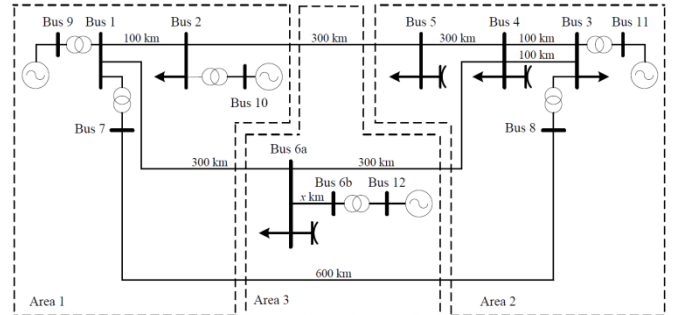

Fig. 3. CIGRÉ European HV grid.

#### B. Pan-European Test Grid developed in ELECTRA

Since the CIGRÉ grid only represents a pure AC grid and ELECTRA focuses on the future power system, it has been extended with a multi-terminal DC grid (MT-DC) and also subjected to a revision of the AC side. Furthermore, the grid topology has been modified in order to create a more diverse and flexible model while trying to keep it as simple as possible. More precisely, in order to represent an equivalent transnational grid, aggregations of loads and of generation units have been adopted, and both conventional and renewable units have been assumed to be connected to most of the buses. The result is reported in Fig. 4. The network includes a 220 and 400 kV AC grid together with a meshed 725 kV MT-DC grid. The three areas in the CIGRÉ grid have become three cells (Cells 1, 2 and 3), and the MT-DC grid is assumed as an additional cell (Cell 4). It has been decided to equip conventional units with either a gas turbine governor or a hydraulic governor; the excitation system models are consistent with ENTSO-E recommendation on transmission system dynamic model [16]; both the governor models and the excitation system models adopted are IEEE standards. Renewable units are modelled as wind turbines of type 3 (i.e., doubly fed induction generator based) and as full converter based generation units, which could represent wind turbines of type 4 or photovoltaics (PV) since both are completely decoupled from the AC grid through the converter and present similar transient behaviour.

The MT-DC grid in Cell 4 connects a Static Generation Unit (SGU) with the AC grid at four different locations via voltage source converters (VSC). The DC voltage level has been chosen so that it allows direct connection of HVDC VSC converters without need of internal transformers for stepping down the AC side. The VSCs are controlled according to a master/slave principle, i.e. Converter 4.3 controls the AC and the DC voltage at its terminals and, thus, acts as the master while the other grid connected converters, i.e. the slaves, control their AC terminal voltage and the

active power flow through them. Converter 4.8 connects the SGU with the MT-DC grid and controls the AC voltage and frequency at the remote AC Bus 4.8. The SGU can represent any kind of converter connected generation, e.g., wind power or PV. Table I gives an overview of the cells' main characteristics.

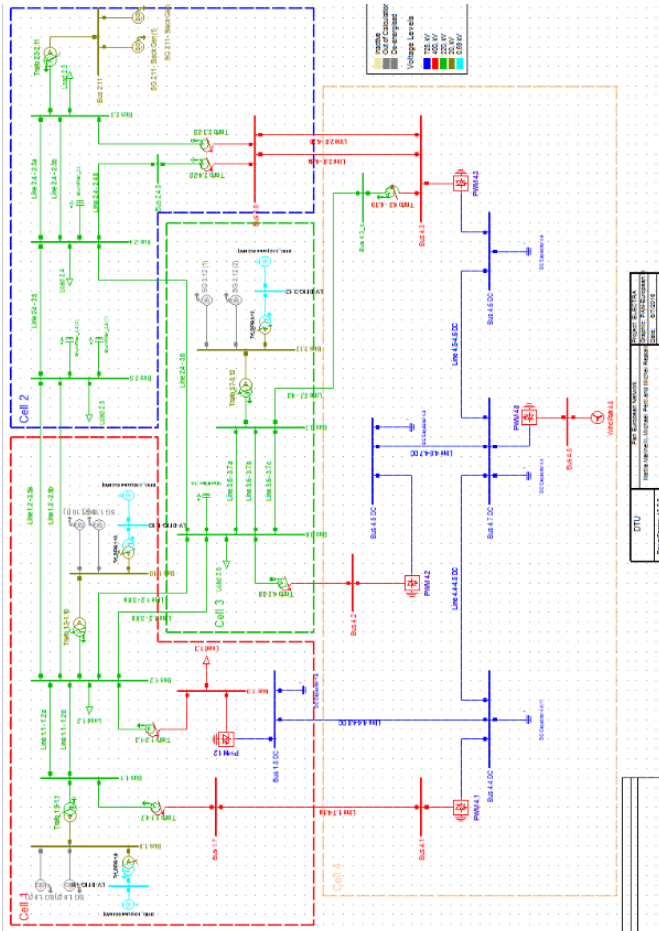

Fig. 4. Topology of the proposed Pan-European reference power system.

It has to be noted that the generation capacity in the system exceeds what is required to cover the demand, so that it is not possible for the generation units to produce full power at the same time. In this way it is possible to investigate several renewable penetration scenarios, having conventional plants progressively displaced (i.e., physically disconnecting synchronous machines from the network) so as to make room for renewable resources.

In order to be able to achieve realistic results with time domain simulations, some preliminary considerations have to be made. These involve, e.g., the models of (a)synchronous machines, transformers, converters and loads. Load modeling has to gain special attention due to its large impact on the results. The loads are here representing the aggregated behaviour of the underlying distribution system. Thus, the loads are modelled as static loads, i.e. the active and reactive power consumed by the loads is sensitive to changes in voltage and frequency. This behaviour is usually described by ZIP models ( $Z$  = constant impedance,  $I$  = constant current,  $P$

= constant power) for voltage dependence, which are extended by a term to account for frequency dependence. The exponential model for voltage dependence extended with a linear model for the frequency dependence is shown in (1) and (2) for active and reactive power consumption, respectively:

$$P = P_0(\bar{V}^\alpha)(1 + K_{pf}\Delta f) \quad (1)$$

$$Q = Q_0(\bar{V}^\beta)(1 + K_{qf}\Delta f) \quad (2)$$

where:

$$\bar{V} = V/V_0 \quad \text{and} \quad \Delta f = f - f_0 \quad (3)$$

- $P, Q$  - actual active/reactive power drawn by the load
- $P_0, Q_0$  - nominal active/reactive power of the load
- $V$  - actual voltage
- $V_0$  - nominal voltage
- $\alpha, \beta$  - exponential coefficients for ZIP characterization (0 = constant power, 1 = constant current, 2 = constant impedance)
- $K_{pf}, K_{qf}$  - linear coefficients for frequency dependence of active and reactive power, respectively

In the reference grid model, the voltage dependence on active power is set to constant current ( $\alpha = 1$ ) and the one of reactive power to constant impedance ( $\beta = 2$ ). However, for voltage values below 0.7 and above 1.2 pu, the voltage dependence is changed to constant impedance in order to minimize computational problems. The coefficients for frequency dependence are set to  $K_{pf} = 1.5$  and  $K_{qf} = -1$ . The coefficients for voltage and frequency dependence are set according to the common practice for stability studies which is also recommended in [17].

Table I  
Overview of the cell main characteristics

	Cell 1	Cell 2	Cell 3	Cell 4
Voltage levels (kV)	20; 220; 400; 725	20; 220; 400	20; 220	400; 725
AC/DC	AC and DC	AC	AC	AC and DC
Nominal generation power ( $P_{nom}$ )	2x400;2x500 MVA synchronous machines (gas turbine governors)  100x6 MW (type 3 wind turbines) 100x6 MW (type 3 wind turbines)	2x700 MVA synchronous machine (gas turbine governor)  note: this machine is used as the slack for load flow calculations	2x500 MVA synchronous machines (hydraulic governors)  100x6 MW (type 3 wind turbines)	1x600 MVA equivalent wind generation (type 4)
Nominal consumption power	2x1000 MW + j 2x165 MVar loads	3x400 MW + j 3x130 MVar loads	1x400 MW + j 1x130 MVar;	no load
Number of tie-lines (AC unless specified differently)	Cell 1-2: 2 Cell 1-3: 2 Cell 1-4: 1 Cell 1-4: 1 DC	Cell 2-1: 2 Cell 2-4: 2 Cell 2-3: 1	Cell 3-2: 1 Cell 3-4: 1 Cell 3-4: 1	Cell 4-1: 1 Cell 4-1: 1 Cell 4-2: 2
Number of internal lines	2x220 kV line	4x220 kV lines	3x220 kV line	3x725 kV lines
Nominal HVDC capacity	1x500 MVA PWM converter	no PWM converter	no PWM converter	3x500 MVA PWM converters

## Simulation scenarios

To carry out the system-wide investigations, several operating scenarios with different levels of RES penetration have been defined. The generation from RES ranges from 0 to 90% with respect to the total load. To set up particularly challenging simulation scenarios, a heavily loaded system has been assumed, since generally the stability of highly loaded systems is lower than the one of lightly loaded systems. This is mainly caused by generators operating closer to their limits. The total load set-point of the system for the proposed scenarios corresponds to 2600 MW with  $\cos(\phi) = 0.95$  (inductive).

Table II summarizes the scenarios key aspects such as RES penetration level – or nominal power  $P_{RES}$  – in relative and absolute values, number and set point of active Synchronous Generators (SGs) and the system inertia  $2H$ . Scenario I provides the base case without penetration of RES and generation exclusively from SGs, i.e. all eight SGs are in service which corresponds to a total system inertia  $2H = 10$  s. In the following scenarios, the RES penetration continuously increases while the share of synchronous generation is simultaneously decreased. SGs are consecutively shut down to keep the active power set-points at a reasonable level. The share of RES generation is equally divided between DFIG wind turbines and full converter generation.

Table II  
Summary of the Defined Simulation Scenarios

Scenario	$P_{RES}$ w.r.t. total load (%)	$P_{RES}$ (MW)	Number of conventional generators in service	SGs setpoint $P_{SG}$ (MW)	Loading of SGs % $P_{nom}$	Total system inertia $2H$ (s)
I	0	0	8	325	76	10
II	25	650	8	244	57	10
III	25	650	6	325	76	7.5
IV	50	1300	6	217	51	7.5
V	50	1300	4	325	76	5
VI	75	1950	3	217	51	3.75
VII	75	1950	2	325	76	2.5
VIII	90	2340	2	130	31	2.5

## IV. CONCLUSIONS

The paper has provided an overview of the current research activities currently carried out in the ELECTRA project, with particular focus on task 5.4 on Pan-European observables. A dedicated reference grid has been defined in order to validate the WoC concept and derive new observables.

An overview of the relevant system-wide topics to be analysed has been presented, highlighting the link with the need for increasing observability. The main characteristics of the reference grid adopted for the investigations have been described. Specific observables will be derived based on angle, frequency and voltage stability studies related to the considered topics.

The final results of the task will be made available in the public deliverable [7] in the early months of 2017. The implemented model in PowerFactory will be made available for research purposes once the task is over.

## ACKNOWLEDGEMENTS

The work in this paper has been supported by the European Commission, under the FP7 project ELECTRA (grant no: 609687; web site [www.ElectraIRP.eu](http://www.ElectraIRP.eu)).

## REFERENCES

- [1] L. Martini, A. Morch, L. Radaelli, C. Caerts, C. Tornelli, S. Hänninen, and H. Brunner, "Electra IRP approach to voltage and frequency control for future power systems with high DER penetration," in *23rd International Conference on Electricity Distribution CIRED*, 2015, pp. 1-4, Lyon, 15–18 June 2015.
- [2] C. Caerts et al., "Specification of Smart Grids high level functional architecture for frequency and voltage control." ELECTRA Deliverable D3.1: WP3 Scenarios and case studies for future power system operation. 2015
- [3] A.Z. Morch et al., "Adaptive Assessment of Future Scenarios and Mapping of Observability Needs." ELECTRA Deliverable D5.1: WP5: Increased Observability. 2015.
- [4] K. Visscher, M. Marinelli, A.Z. Morch, and S.H. Jakobsen, "Identification of observables for future grids - The framework developed in the ELECTRA project," in *PowerTech, 2015 IEEE Eindhoven*, pp.1-6, June 29 2015-July 2 2015.
- [5] A. Morch, S. H. Jakobsen, K. Visscher, and M. Marinelli, "Future control architecture and emerging observability needs," *Power Engineering, Energy and Electrical Drives (POWERENG)*, 2015 International Conference on, pp. 1-5, Riga, 11-13 May 2015.
- [6] M. Rezkalla, K. Heussen, M. Marinelli, J. Hu, and H.W. Bindner, "Identification of Requirements for Distribution Management Systems in the Smart Grid Context," *Universities Power Engineering Conference (UPEC)*, 2015 Proceedings of the 50th International, pp. 1-6, Staffordshire, 1-4 Sep. 2015.
- [7] M. Marinelli et al., "Functional description of the monitoring and observability detailed concepts for the Pan-European Control Schemes." ELECTRA Deliverable D5.4: WP5 Increased observability. 2016 – in press.
- [8] P. Kundur, J. Paserba, V. Ajjarapu, G. Andersson, A. Bose, C. Canizares, N. Hatziargyriou, D. Hill, A. Stankovic, C. Taylor, T. Van Cutsem, and V. Vittal, "Definition and classification of power system stability IEEE/CIGRE joint task force on stability terms and definitions," *Power Systems*, IEEE Transactions on, vol.19, no.3, pp.1387-1401, Aug. 2004.
- [9] M. Pavella, D. Ernst, and D. Ruiz-Vega, "Transient Stability of Power Systems A Unified Approach to Assessment and Control," *Kluwer Acad. Publ.*, pp. 1–254, 2000.
- [10] L. L. Grigsby, "Power System Stability and Control. The Electric Power Engineering Handbook," CRC Press/IEEE Press, 2001.
- [11] ENTSO-E, "Continental Europe Operation Handbook", Policy 1 and Annex to Policy 1, 2009. <https://www.entsoe.eu/publications/system-operations-reports/operation-handbook/Pages/default.aspx>
- [12] V. Knap, R. Sinha, M. Swierczynski, D.-I. Stroe, and S. Chaudhary, "Grid inertial response with Lithium-ion battery energy storage systems," in *Industrial Electronics (ISIE)*, 2014 IEEE 23rd International Symposium on, pp.1817-1822, 1-4 June 2014.
- [13] R. Kumar, "Assuring voltage stability in the smart grid," in *Innovative Smart Grid Technologies (ISGT)*, 2011 IEEE PES, 2011, pp. 1–4.
- [14] THEMA Consulting Group, "Loop flows - Final advice", prepared for the European Commission [https://ec.europa.eu/energy/sites/ener/files/documents/201310\\_loop-flows\\_study.pdf](https://ec.europa.eu/energy/sites/ener/files/documents/201310_loop-flows_study.pdf)
- [15] CIGRÉ Report "Benchmark Systems for Network Integration of Renewable and Distributed Energy Resources", CIGRE Task Force C6.04.02, July 2009.
- [16] ENTSO-E Report "Documentation on controller tests in test grid configurations", ENTSO-E Sub-Group System Protection and Dynamics, 26 November 2013.
- [17] K. Sun, "Power System Operations & Planning - Load Modeling" 2015.