



# Open Research Online

---

The Open University's repository of research publications and other research outputs

## Design study for wire and arc additive manufacture

### Journal Item

How to cite:

Mehnen, Jorn; Ding, Jialuo; Lockett, Helen and Kazanas, Panos (2014). Design study for wire and arc additive manufacture. *International Journal of Product Development*, 19(1/2/3) pp. 2–20.

For guidance on citations see [FAQs](#).

© 2014 Inderscience Enterprises Ltd.

Version: Version of Record

Link(s) to article on publisher's website:

<http://dx.doi.org/doi:10.1504/IJPD.2014.060028>

<http://www.inderscience.com/info/inarticle.php?artid=60028>

---

Copyright and Moral Rights for the articles on this site are retained by the individual authors and/or other copyright owners. For more information on Open Research Online's data [policy](#) on reuse of materials please consult the policies page.

---

[oro.open.ac.uk](http://oro.open.ac.uk)

---

## **Design study for wire and arc additive manufacture**

---

### **Jörn Mehnen\* and Jialuo Ding**

Manufacturing and Materials Department,  
School of Applied Science,  
Cranfield University,  
Cranfield, Bedfordshire, MK43 0AL, UK  
Email: j.mehnen@cranfield.ac.uk  
Email: jialuo.ding@cranfield.ac.uk  
\*Corresponding author

### **Helen Lockett**

Department of Aerospace Engineering,  
School of Engineering,  
Cranfield University,  
Cranfield, Bedfordshire, MK43 0AL, UK  
Email: h.lockett@cranfield.ac.uk

### **Panos Kazanas**

Aerospace Vehicle Design Department,  
School of Engineering,  
Cranfield University,  
Cranfield, Bedfordshire, MK43 0AL, UK  
Email: p.kazanas@cranfield.ac.uk

**Abstract:** Additive Manufacture (AM) is a technique whereby freeform structures are produced by building up material in a layer by layer fashion. Among the different AM processes, Wire and Arc Additive Manufacture (WAAM) has the ability to manufacture large custom-made metal workpiece with high efficiency. A design study has been performed to explore the process capabilities of fabricating complicated geometries using WAAM. Features such as enclosed structures, crossing structures, and balanced building structures have been investigated in this study. Finite Element (FE) models are employed to take the thermo-mechanical performance into account. Robot tool path design has been performed to transfer the WAAM component designs into real components efficiently. This paper covers these essential design steps from a technical as well as practical point of view.

**Keywords:** additive manufacture, wire and arc additive manufacture, design for manufacture, FE simulation.

**Reference** to this paper should be made as follows: Mehnen, J., Ding, J., Lockett, H. and Kazanas, P. (XXXX) 'Design study for wire and arc additive manufacture', *Int. J. Product Development*, Vol. X, No. Y, pp.xxx-xxx.

*J. Mehnen et al.*

**Biographical notes:** Jörn Mehnen has a background in computer science, mathematics, statistics as well as mechanical engineering, having done an MSc, PhD and Habilitation at TU Dortmund, Germany. He joined Cranfield University in 2007 at the Manufacturing Department as a Senior Lecturer. He has a vast background in soft computing as well as engineering process virtualisation. Since he joined Cranfield University he has been the Principal Investigator of four major national projects and been involved in three national Research and Technology Development projects as well as EU funded projects. He has published extensively in his research career. He is on the review panel of more than 10 leading journals.

Jialuo Ding received her Bachelor's degree in Mechanical Engineering from Yanshan University, China in 2005. She received her double Master's degree from Cranfield University (UK) and Beihang University (China) in 2008. She is currently a PhD student in the Manufacturing and Materials Department of Cranfield University. Her research interests include thermo-mechanical FE modelling, additive manufacturing process, robotics and optimisation.

Helen Lockett is a Senior Lecturer in the School of Engineering at Cranfield University. Her research interests are in engineering design and computer aided design, particularly focused on the development of techniques to support design for manufacture/ maintainability. In her PhD research she developed a knowledge based manufacturing advisor for moulded parts. More recently she has investigated the design opportunities for additive manufacture, particularly for aerospace applications. She has also undertaken research in design for maintainability and the extended lifecycle, utilising information collected from products in-use.

Panos Kazanas obtained his Mechanical Engineering in 1993 in Aristotle University of Thessaloniki. He obtained his MSc in CAD/CAM from Cranfield University in 1995 and worked in the oil & gas industry for 11 years. He returned to Cranfield to obtain an MSc in Welding Engineering. He is currently a PhD student in the AVD Department of Cranfield University. His research interests include Design for Additive Manufacturing (AM) process with weld metal deposition and FEA analysis of AM proposed designs.

---

## 1 Introduction

Aerospace industry estimates requirements of about 20 million tonnes of billet material over the next 20 years. With machining rates of ca. 90% and ever increasing material costs especially in titanium (Wood, 2009), conventional manufacturing strategies need reconsideration. New sustainable, cost and time efficient, and environmentally friendly manufacturing processes are required by the modern industry. New Additive Manufacturing (AM) technologies are currently the subject of significant interest. Among the different AM processes, Wire and Arc based Additive Manufacturing (WAAM) technologies provide new routes to manufacture near net shape metal parts. In the WAAM process, 3D metallic components are built by depositing beads of weld metal in a layer by layer fashion (Spencer et al., 1998). Standard welding processes, such as Gas Metal Arc Welding (GMAW) and Gas Tungsten Arc Welding (GTAW), can be utilised in WAAM which provide high deposition rates. Modern automation technologies enable high geometric flexibility. With the local shielding technique, highly reactive metallic

### *Design study for wire and arc additive manufacture*

components can be fabricated in an out-of-chamber environment (Almeida and Williams, 2010). Various materials can be applied in the WAAM process, such as steel, aluminium alloy and titanium alloy (as shown in Figure 1).

**Figure 1** WAAM components: (a) mild steel honeycomb structure; (b) aluminium stiffened panel structure; (c) 1 metre long Ti64 wall structure (see online version for colours)

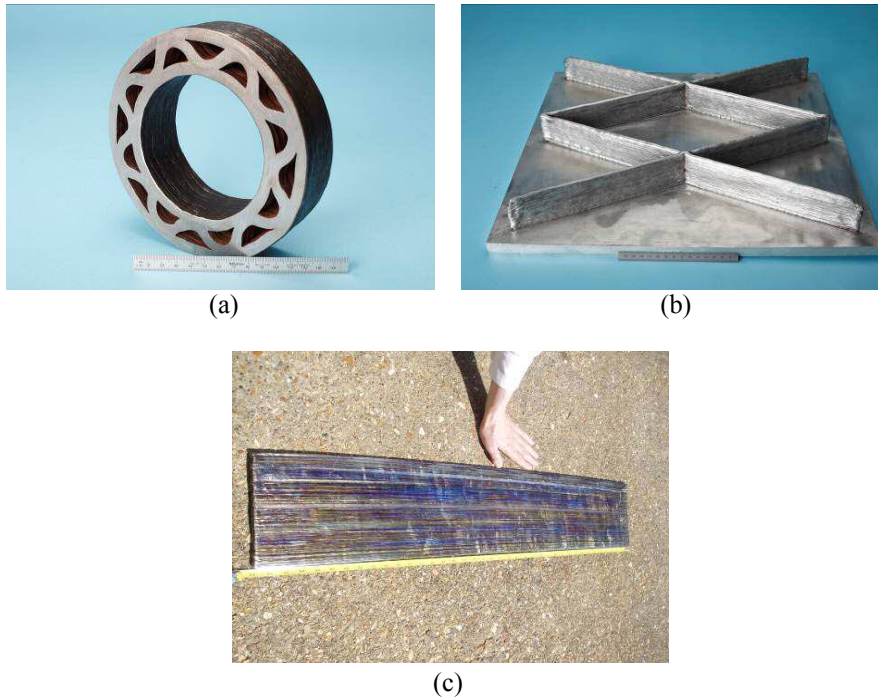

In order to achieve a well integrated process that utilises the full power of the AM technique, each process step has to be set up and linked optimally. Design for WAAM identifies workpiece geometries that are most suitable for the final real-world applications. For example, in aerospace new light weight stiffeners are used which need to satisfy specific mechanical constraints. AM is an ideal way of manufacturing and testing innovative designs because AM removes many of the constraints that one typically encounters in conventional manufacturing (Lockett and Kazanas, 2009; Bernard and Fischer, 2002; Bernard and Karunakaran, 2007). The final quality of the WAAM components depends on the deposition strategy which needs to be explored with different design plans.

The wire based welding techniques used in the WAAM process can provide high deposition rates. However, the large heat input of these processes also brings significant residual stresses and distortions. These issues can badly impact the accuracy of the final shape of the parts and their mechanical performance. Therefore, it is important to take the thermo-mechanical behaviour of the WAAM process into consideration during the design stage. FE modelling is a widely used technique in the area of welding (Casalino and Ludovico, 2008; Murugan et al., 2001; Colegrove et al., 2010) and AM processes (Chin et al., 2001a; Chin et al., 2001b; Mughal et al., 2006; Nickel et al., 2001; Ding et al., 2011). With the great improvement of the computer power, 3D transient thermo-

mechanical model became the most popular model. A moving heat source is usually utilised with filler material model which can provide accurate predictions ([Mughal et al., 2006](#); [Nickel et al., 2001](#)). However, this conventional transient model is not suitable for the thermo-mechanical analysis of large-scale WAAM components because of the long computational time. A more efficient model has been introduced based on the steady-state thermal analysis which can save around 80% computational time ([Ding et al., 2011](#)). This model attaches an Eulerian reference frame to the welding torch and the material “flows” through the FE mesh. Steady state temperature distributions are calculated and are used as an input to a 3D mechanical model for residual stress and distortion analysis.

Design for WAAM also tackles the issues of how to efficiently transfer the design into the real-world manufacture. In the actual WAAM process, the welding paths are executed by a robotic system. The conventional robot programming with a teach pendant is very time-consuming especially for complex paths. To generate a robot programme efficiently, some researchers “mirror” milling tool paths generated from commercial CAD/CAM software or use sliced routines from Rapid Prototyping software ([Ericsson et al., 2005](#)). However, both these ways are not flexible because of software constraints. Therefore, researchers often develop their own tools to achieve specific part designs ([Ribeiro, 1998](#); [Zhang et al., 2002](#)). An automatic robot path generation tool has been generated in this research to generate robot code directly from CAD models. This tool can significantly reduce the time on robot programming from hours with a teach pendant to a couple of minutes. Moreover, the optimal deposition parameters process ([Mehnen and Trautmann, 2008](#)) can be easily integrated in the deposition using this tool.

This paper touches on the design for WAAM process, in particular, the design of unconventional stiffeners. A study with different designs of the stiffeners is introduced to decide the best structures. Different building strategies have been explored through experiments. Thermo-mechanical FE models are developed to predict the thermally induced stresses and distortions. At last, the automatic generation of robot tool paths from CAD data is discussed.

## **2 Design of stiffened panels**

WAAM has the potential to transform current models of manufacturing because it gives designers the freedom to produce parts with a wide range of geometric shapes, without many of the shape or accessibility constraints of traditional manufacturing processes. WAAM also increases manufacturing flexibility because parts can be tailored for bespoke production without the high tooling costs associated with existing manufacturing processes. This section will present the results of an investigation into the design of stiffened panels with unconventional stiffeners that could be produced using WAAM.

A WAAM design study has investigated various designs for stiffened panels. These light weight panels can be used for aerospace applications. The WAAM process allows the design of quite unconventional structures that show a greatly improved buckling performance in comparison to traditional stiffener designs. WAAM parts can be designed to specific load cases and can therefore be more flexibly designed than workpieces that are fabricated from metallic billets. WAAM provides a more sustainable solution to integral machining because the amount of waste material can be greatly reduce using WAAM.

*Design study for wire and arc additive manufacture*

The design studies for WAAM stiffened panels were performed in two steps in silico. In the first step, five different panel designs were included. CAD models of the stiffened panels were generated and stresses under uni-axial loads were analysed using FE models. The dimension of the substrate plate for each model is 500 mm × 500 mm, and the stiffener's height is 50 mm. As shown in Figure 2(a), loads with density of 100 N/mm were applied on opposite edges of the plate in the x direction. Two material properties, Ti-6Al-4V and generic mild steel, are utilised in this study.

The results of the analyses are shown in Figure 2(b). The results are presented using the buckling index which is defined as the buckling load per kilogram (kN/kg). A lighter structure with the same buckling load will have a higher buckling index. One can see that the simple unsupported plate has, of course, a very small buckling index of 3.61 and 3.71 for titanium and steel, respectively. The complex wave structure has only a slightly higher index than the plain steel plate. Thus, this design can be ruled out as a useful support solution. The blade structure and the curve structures can improve the buckling index four to five times. The corrugation design is the best from all these designs which can significantly increase the buckling index to nearly 14 times higher than the plain plate in mild steel and around 12 times higher in Ti-6Al-4V. This corrugation stiffener cannot be produced using conventional machining due to the need to produce an enclosed void inside the stiffener.

**Figure 2** Selected WAAM panel designs with uni-axial load applied: (a) uni-axial load; (b) buckling index (see online version for colours)

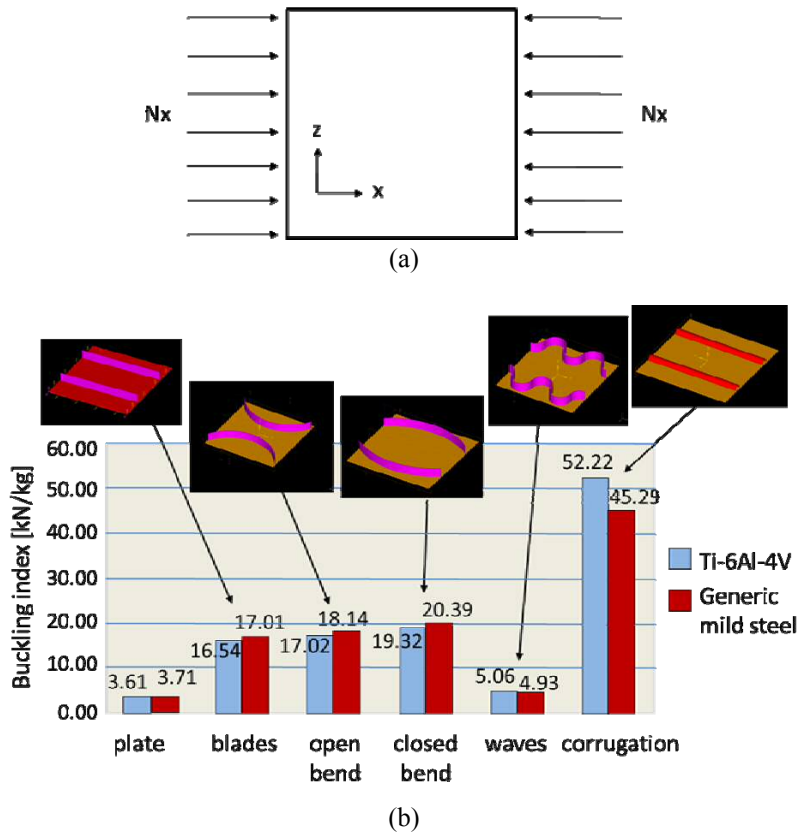

A new study was performed on further four designs of the stiffener panel which introduced crossing structures with straight walls and curved walls. The mechanical performance under bi-axial loads was analysed using FE models. The same dimension of the substrate plate and stiffener's height is utilised in this study as in the last study. As shown in Figure 3(a), loads with density of 100 N/mm were applied on the edges of the plate in both x and z direction. Figure 3(b) shows the buckling index for each model. One can see that the crossing structure can improve the buckling index significantly. The structure with the combinations of open curves and the closed curves increased the buckling index more than nine times comparing to the plain plate.

**Figure 3** Selected WAAM panel designs with bi-axial load applied: (a) uni-axis load; (b) buckling index (see online version for colours)

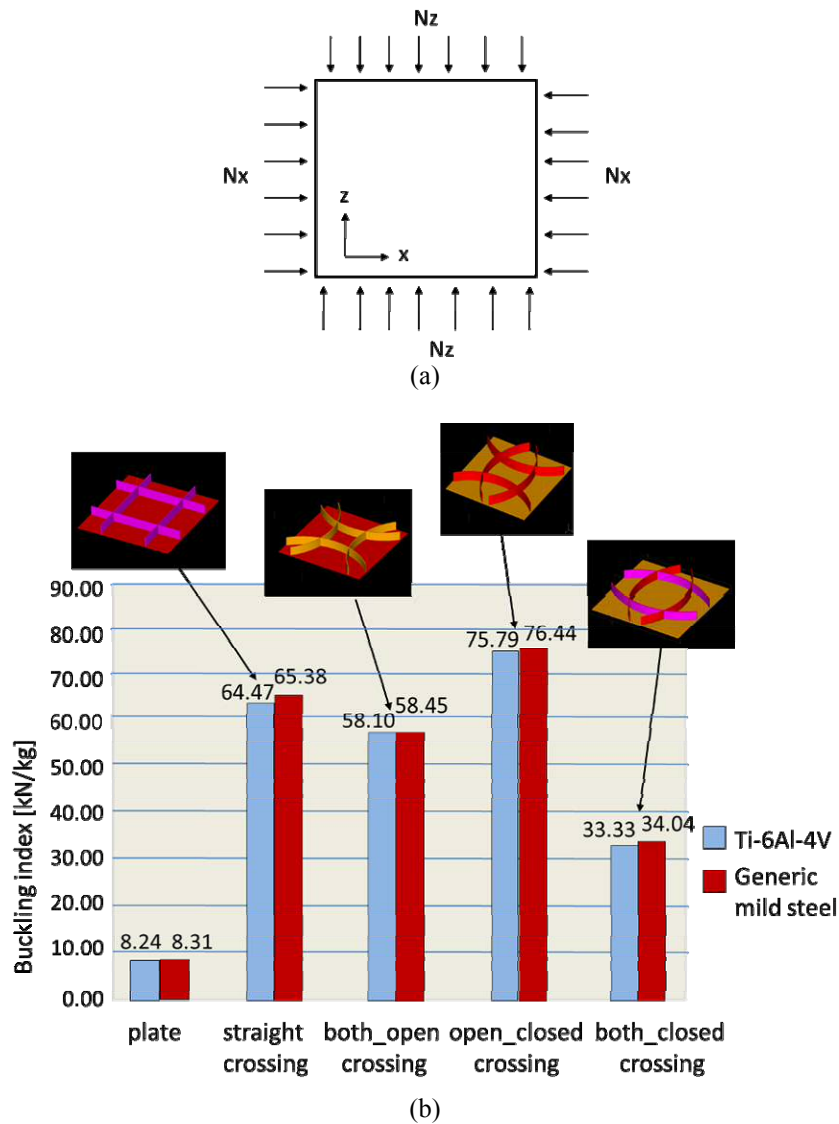

### **3 Manufacture of WAAM features**

WAAM has the advantage that one can manufacture parts with geometric features that cannot be produced using conventional machining processes, with greatly reduced waste material. In the study of last section, the corrugation structure and crossing structures show their significant advantage with high buckling index. However, WAAM also has its limitations which have to be taken into account during the design for WAAM. This section will present the results of practical experiments to produce a range of design features using WAAM.

#### *3.1 Enclosed structure*

The corrugation structure can greatly increase the buckling index. However, this structure involves enclosed features. It needs different deposition strategies to the fabrication of normal vertical walls where the torch position is vertical to the substrate. In the powder based AM process, additional support items are usually required for building non-vertical structures ([Weiss et al., 1997](#)). An initial experiment has been performed to investigate the process' capability of producing inclined walls that could be incorporated in real world parts using the WAAM process. The experiments were performed using the Cold Metal Transfer (CMT) technique. The details of this initial study have been published by [Kazanas et al. \(2012\)](#). Based on the result of this earlier study, building strategies for more complicated geometrical features, such as enclosed structures and cross structures, are investigated in the present study.

The initial study demonstrated that inclined walls can be produced as shown in Figure 4(a). The angle of the torch is set to be equal to the targeted wall angle. The torch is offset after every bead in the direction of the wall growth. Furthermore the torch welding travel direction is reversed after each layer deposited. Figure 4(b) shows mild steel walls built with angles 60°, 45°, 30° and 15° to the substrate. The capability of building horizontal wall is also explored using the WAAM process as shown in Figure 4(c). No support in any of these walls has been utilised.

The knowledge obtained from the previous experiments has been used to fabricate enclosed shapes. As shown in Figure 5(a), an enclosed shape with rectangular section has been successfully fabricated. The two vertical walls were built first and then they were bridged by a horizontal wall. A further development for the process was the production of the enclosed shape with the section of half circle (as shown in Figure 5(b)). It was produced by building two quarter circles and joining them in the middle. Although the quarter circles were built –using WAAM and a standard gas metal arc welding (GMAW) process was selected for joining them. This was done in order to provide higher heat input and achieve better fusion for the entire thickness of the joint. This enclosed semi-circle feature demonstrates the ability to build corrugation stiffened panels without support structures.



**Figure 4** Inclined wall fabrication: (a) deposition strategy; (b) inclined WAAM walls with different angles; (c) horizontal wall (see online version for colours)

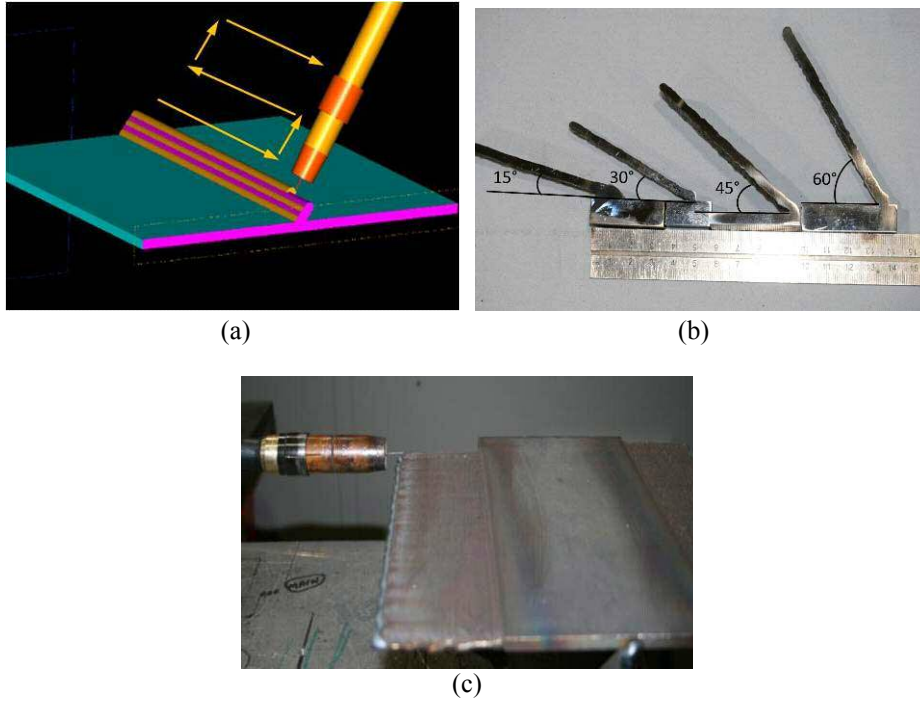

**Figure 5** Enclosed structures with section of (a) 50 mm square; (b) 50 mm radius semicircle (see online version for colours)

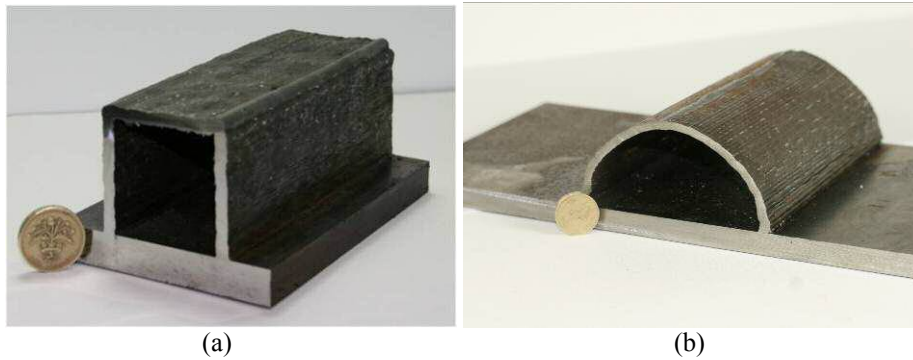

### 3.2 Cross structure

An investigation into the feasibility of manufacturing cross structures using WAAM has also been performed. This study focuses on cross structures with straight walls. CMT facilities were utilised and the welding parameters were set to produce 4 mm thick walls with 0.8 mm mild steel wire. Initial investigations found that building a cross structure

*Design study for wire and arc additive manufacture*

by successively depositing two perpendicular walls caused undesirable features such as peak development and deposition failure as shown in Figure 6. The peak at the wall intersection is due to the overlap of the weld beads in this area and the deposition failure is caused by the accumulation of a depression on one side of the crossing. As demonstrated in Figure 6(b), once the depression was generated it caused an unstable arc when the welding torch passed this area. The effect worsens when more layers of weld beads are added which finally generates an obvious gap and causes arc failure.

**Figure 6** Undesirable features of crossing structure: (a) Peak development; (b) deposition failure (see online version for colours)



In order to further study the peak development problem four 200 mm x 200 mm cross shapes have been fabricated. Each wall was fabricated with a different build pattern as shown in Figure 7. The four build patterns investigated were *Direct Crossing* which uses a repeated pattern of perpendicular layers, *Direct Crossing 2* in which the direction of travel is reversed after each layer, *Opposite Angles* which is deposited as two “back to back” L-shapes and *Opposite Angles 2* which is deposited as L-shapes starting from each of the four cross members in turn.

**Figure 7** Layer deposition strategies for crossings: (a) Direct Crossing, (b) Direct Crossing 2, (c) Opposite Angles, (d) Opposite Angles 2

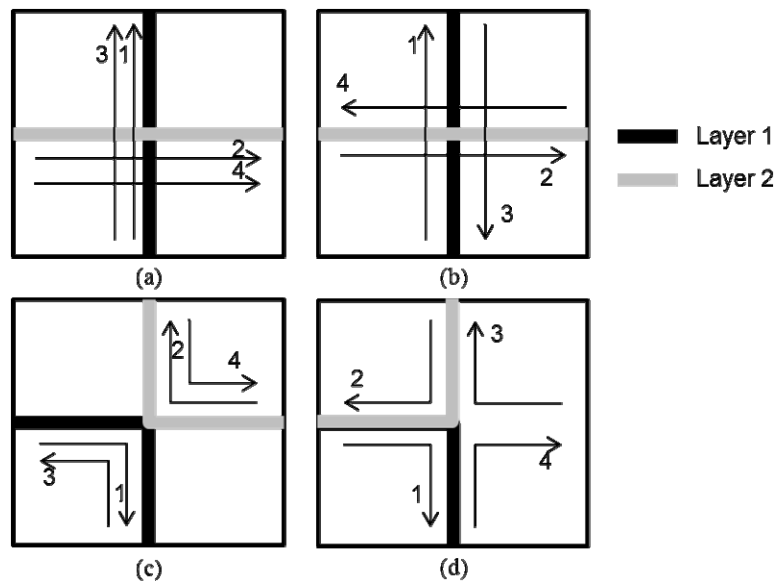

Measurements were taken after every five layers in the locations indicated in Figure 8 (on all four cross members), using a digital Vernier calliper. The peak value ( $hp$ ) has been compared to the average wall height (excluding the peak measurement) for each layer. The results were plotted against the layer number for 30 layers as shown in Figure 9.

**Figure 8** Measurement locations for peak development study (side elevation)

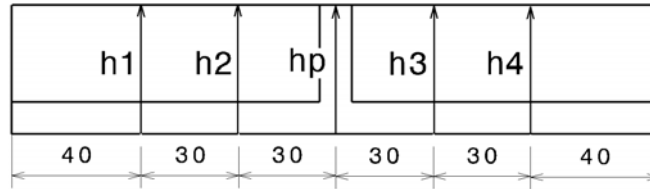

**Figure 9** Peak height measurements for different crossing build patterns

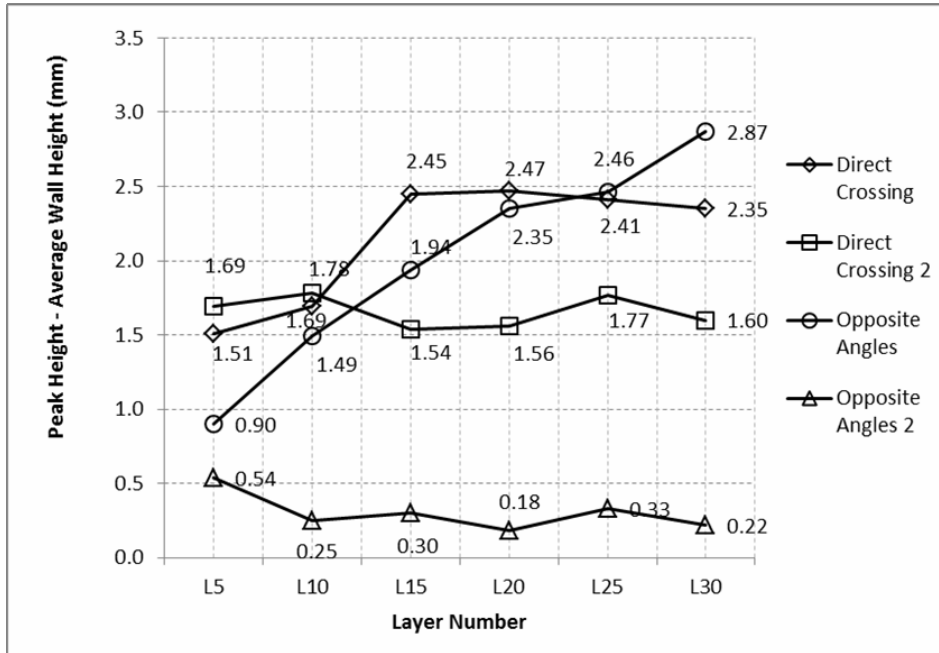

The results show that for the *Opposite Angles* build pattern the peak continues to increase in height for all 30 layers, and for the *Direct Crossing* build pattern the peak increases in height for 15 layers. The *Direct Crossing 2* and *Opposite Angles 2* strategies achieve a stable peak height after 5 layers. The *Opposite Angles 2* method has the lowest peak values at less than 0.4 mm, and the *Direct Crossing 2* pattern less than 1.8 mm. Both of these strategies give acceptable results for practical purposes.

Figure 10 shows how the deposition failure is eliminated by reversing the building direction after each layer using the *Direct Crossing 2* build pattern. Using this pattern the depression which is generated in one layer is levelled out by the next. Figure 11 shows a

*Design study for wire and arc additive manufacture*

section through the cross structure produced using the building pattern *Opposite Angles 2* and shows that the peak at the crossing is small using this pattern. The cut section shows smooth radii in the intersection corners. The *Opposite Angles 2* build pattern achieves the best results but is more complex to program than the direct crossing pattern.

**Figure 10** Schematic diagram of (a) development of deposition failure; (b) elimination of deposition failure

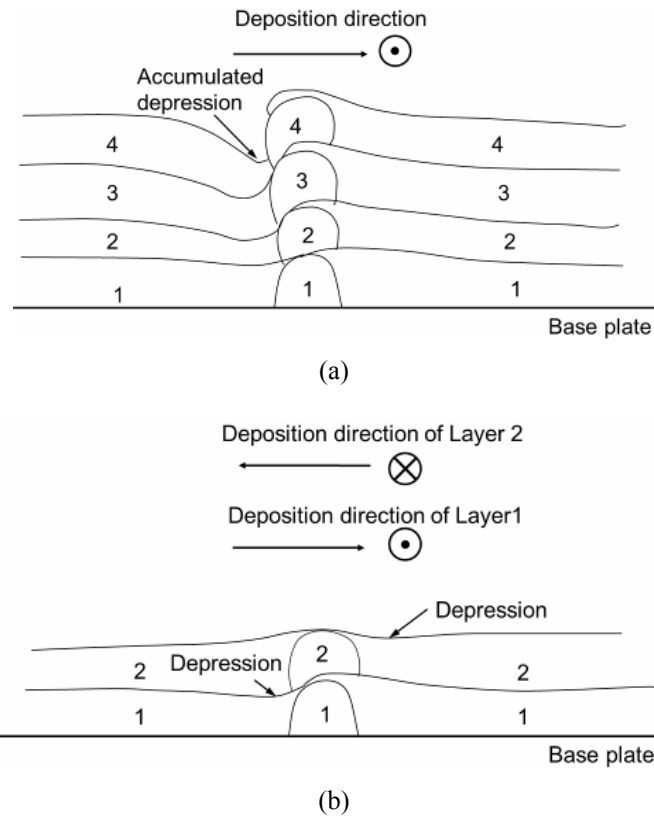

**Figure 11** Example of crossing feature manufactured using build pattern *Opposite Angles 2*: (a) cross structure; (b) cut section (see online version for colours)

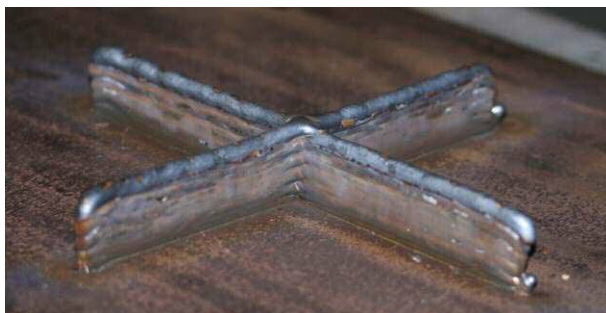

(a)



(b)

The experiments discussed in this section have demonstrated a basis to allow designers to consider WAAM as an alternative to conventional metal processes. The ability to produce inclined and horizontal walls without support structures, and the combination of wall features to produce crossings and closed section shapes provides the foundation for producing a wide range of practical, structural designs using WAAM. WAAM could also be coupled with other processes such as casting and extrusion in order to provide even greater flexibility and reduce the cost of expensive tooling.

#### **4 FEM modelling of WAAM process**

In order to predict the thermo-mechanical behaviour of the WAAM process, a three dimensional FEM model has been developed. Two modelling strategies have been utilised. In the first strategy a transient thermal analysis was performed and the nodal temperature histories were applied as an input in the sequential mechanical simulation. Temperature depended material properties were used for both thermal and mechanical simulation. The heat source was modelled using the Goldak ellipsoidal model moving along the weld bead (Goldak et al., 1984). The material adding process is modelled by activating the meshes successively with the moving heat source. The thermal boundary conditions include convection heat loss, radiation heat loss, and the heat loss through the cooling plate beneath the base plate. The mechanical boundary condition took the clamping system into consideration. The details of this model and the verifications on a multi-layered wall structure have been published in a previous paper (Ding et al., 2011). Based on this model, a further study was made on the thermo-mechanical performance of utilising WAAM process on the cross structures. In addition, a balanced build strategy was investigated using the FE model.

Figure 12 demonstrates the transient temperature and stress performance of the WAAM process on a multi-layered wall structure. Only half the wall structure has been modelled due to symmetry. Figure 12(a) shows the temperature profile when the heat source travelled 35 mm along the fourth layer of the deposited wall. The area with grey colour represents the fusion zone where the temperature exceeds 1500°C. As the welding torch travelled the melt metallic material added to the wall and heated up the adjacent area. The temperature dropped dramatically in the area behind the fusion zone. The material from the previously deposited layers was reheated when the new material was added.

Figure 12(b) shows the corresponding longitudinal stress distribution. One can see that the stress in the area where the material was heated up by the welding torch is very low because of the significantly reduced yield stress level by the high temperatures. Compressive stress was generated in front of the fusion zone due to the thermal expansion of the heated material. Tensile stress was generated in the area behind the heat source due to the contraction of the cooling material which was constrained by the base plate to maintain the original length. This in turn results in longitudinal compressive residual stresses in the base plate, especially in the area where the clamps were located. The tensile stress from the already deposited material was released as the material was reheated. However, the tensile stress was generated again in this area after the heat source past.

*Design study for wire and arc additive manufacture*

With this transient FE model, the thermo-mechanical performance of building the crossing structure has been analysed. Two of the build strategies have been proved to be able to achieve good quality. Two of the building strategies (*Direct Crossing 2* and *Opposite Angles* – see Figure 7) were investigated in this study –. The thermally induced residual stresses were compared between these two building patterns.

The size of the base plate in the FE model is  $100 \times 100 \times 12$  mm. The width of the crossing wall is 5 mm, and the layer height is 2 mm. Each model was built with two layers of material deposited on the base plate. An interpass cooling time of 5 seconds was used between subsequent layers. The clamps were modelled on the four corners of the base plate.

**Figure 12** Transient thermo-mechanical performance: (a) temperature profile when the heat source travelled 35 mm along the fourth layer of the deposited wall; (b) corresponding longitudinal stress distribution (see online version for colours)

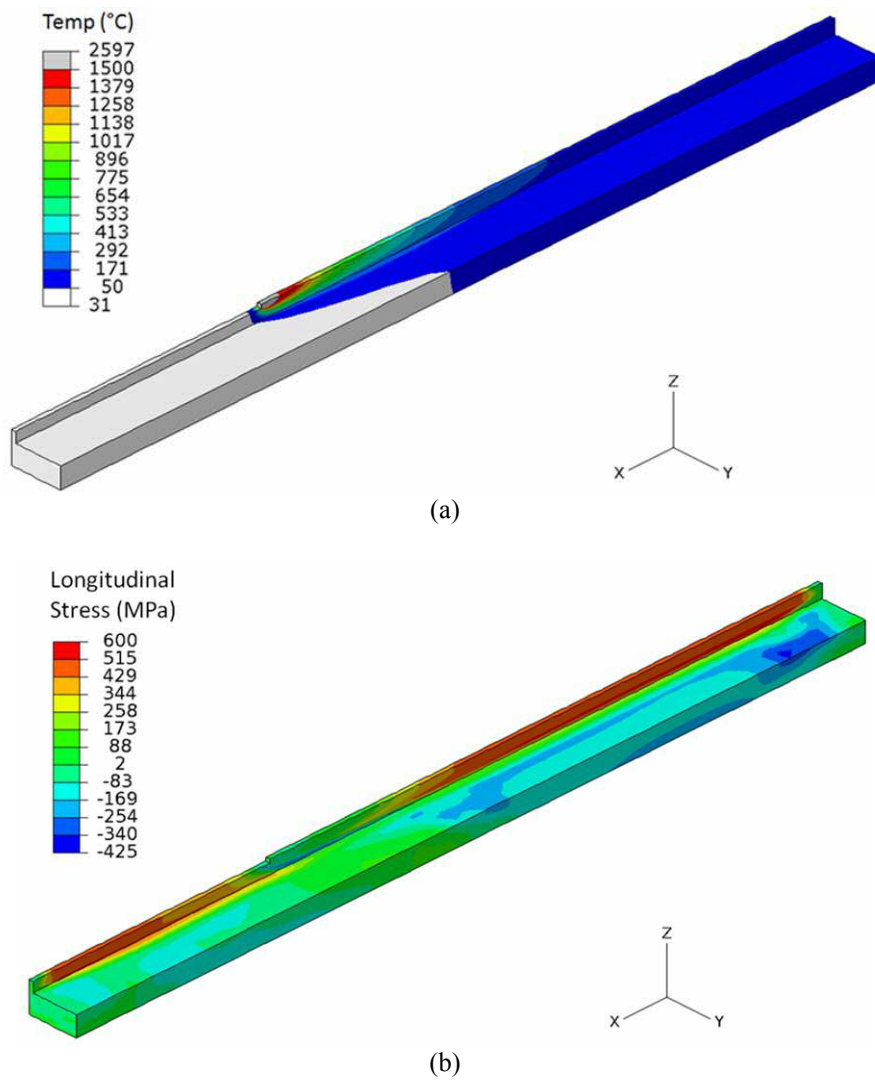

As shown in Figure 13, the results from the two different building strategies gave very similar stress distributions. High level tensile stresses were generated along the walls on their deposition directions. Note that in both cases the stress level in the middle area of the deposited cross was much lower than the rest of the deposited wall. The possible reason is that the crossing structure increased the stiffness of the intersection area which reduced the stress level. Balanced compressive stresses were distributed in the surrounding areas of the deposited wall. Symmetric compressive stresses were developed in the component that built with building pattern of direct crossing, while slightly dissymmetric compressive stresses were distributed in the component using building pattern of opposite angles. It is very difficult to tell which deposition pattern is better in the consideration of the thermo-mechanical performance as the difference of the residual stresses generated by these two patterns is very small.

**Figure 13** Stress distribution on cross structure: (a) stress along x direction from building pattern of direct crossing; (b) stress along x direction from building pattern of opposite angles; (c) stress along y direction from building pattern of direct crossing; (d) stress along y direction from building pattern of opposite angles (see online version for colours)

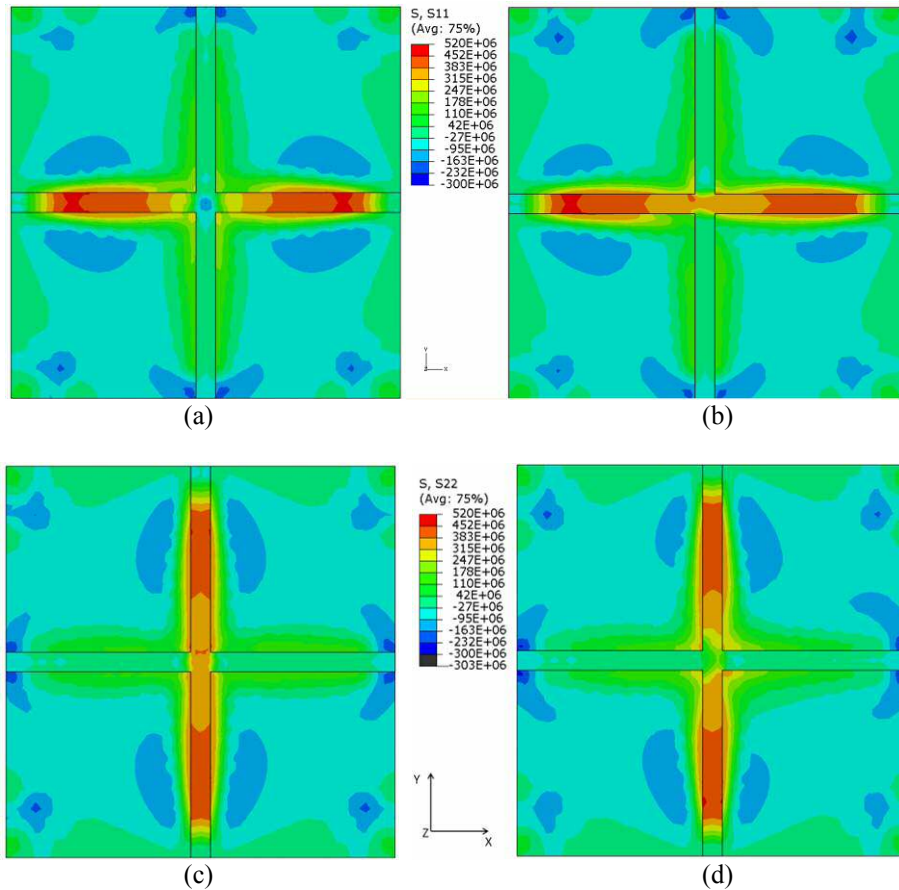

The FE model was also utilised for the thermo-mechanical performance of the balanced build strategy. The balanced building strategy adds materials on both sides of the base

### *Design study for wire and arc additive manufacture*

plate. It has been verified through experiments that the out-of-plane deformation can be greatly reduced using this method. Figure 14 shows a Ti64 frame structure fabricated with the balanced building strategy. The walls with frame features were built on one side of the base plate first and then the base plate was turned over for depositing the same structures on the other side. As can be seen from Figure 14, nearly no out-of-plane distortion can be observed on the final component.

**Figure 14** Frame structure manufactured with the balanced building strategy (see online version for colours)

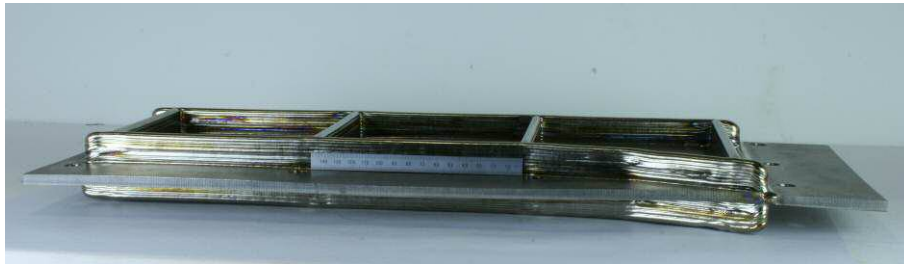

The thermo-mechanical performance of a double sided wall structure was studied to help understand the mechanism behind the balanced building strategy. A different FE to the previously used transient FE approach was utilised in this study. In this model, the thermal analysis was performed in a steady-state way. The static thermal distribution was then transferred into temperature history data and was input into the mechanical model as thermal loads. This modelling approach can significantly save computational time which is particularly suitable for the thermo-mechanical analysis of the large scale WAAM process. The details of this approach and the verification on a multi-layered wall structure can be found in (Ding et al., 2011).

In this study, two walls with 5 layers were modelled on both sides of a base plate with the dimension of 250 mm × 60 mm × 6 mm. The weld beads are 5 mm in width and 2 mm in height. Five layers of materials were deposited on one side of the base plate and then another five layers of materials were added on the other side of the base plate. The clamping system was set on the long edge of the base plate which constrained the movement of the component during the deposition process. Another model with five layer materials built on one side the base plate only was also provided to show comparison with the models with the balanced building strategy.

The stress in the longitudinal direction is dominant to the stresses in the other directions. The longitudinal stress distributions that were generated after the completion of the deposition are shown in Figure 15. It can be observed from Figure 15(a) that in the single sided wall structure uniformly distributed tensile stresses are generated across all the layers of the deposited wall. The stresses in the base plate adjacent to the deposited wall are also tensile, and the longitudinal stresses go into compression near the bottom of the base plate. When building on both sides of the base plate similar level of tensile stresses are generated along the deposited walls on both sides of the base plate (Figure 15(b)). Compressive stresses are generated in the base plate, however the magnitude is lower than those generated in the base plate of the single sided wall structure.



**Figure 15** Stress distribution of: (a) single sided wall structure, (b) double sided wall structure built (view cut has been applied on the mid-length of the models) (see online version for colours)

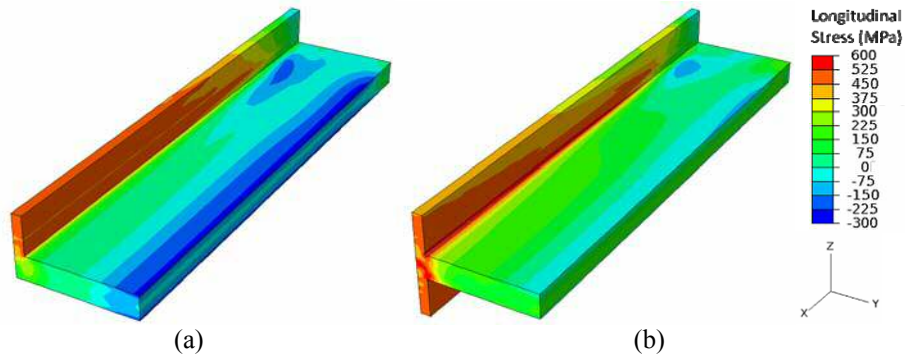
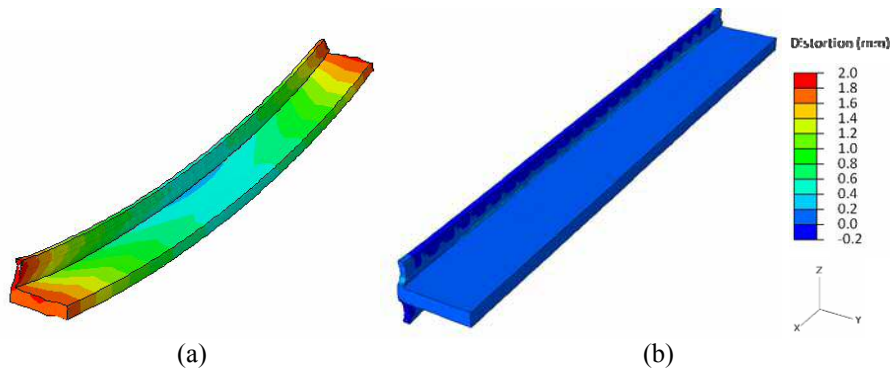

Figure 16 shows the distortions after the clamps are removed. One can see that the single-sided wall structure generated significant out-of-plane distortions due to the uneven distribution of the stresses. In contrast, the level of the out-of-plane distortions generated by the double-sided wall structures was negligible. Balanced stresses were generated by building structures from both sides of the base plate, thus very little distortion was generated.

**Figure 16** Distortion after clamps are removed: (a) single sided wall structure, (b) double sided wall structure (deformation scale factor: 10) (see online version for colours)



## 5 Robot path determination

In order to efficiently realise the WAAM designs, a robot path generation program has been developed in Matlab. This tool contains two main modules – a slicing module and a robot program generation module. By executing these two modules automatically, the program can slice the designed AM parts and generate the ready-to-use path code for a Fanuc robot in one go. A user-friendly interface has also been developed to simplify the setting of parameters.

*Design study for wire and arc additive manufacture*

The function of the slicing module generates isolines from the CAD model and produces the sequenced points on the path. The algorithm generated for this module can remove duplicate points which usually appear when CAD models with poor triangulation quality are sliced. The program also supports the user in reducing the number of output points by setting up the tolerance which is very useful for building large parts.

The robot program generation module takes these points and generates a Fanuc robot program in ASCII format. Some key parameters for the welding process can easily be set by the users, including welding process parameters such as arc on/off position, travel speed of the welding torch, waiting time between layers, building sequence for the part with several sub-parts, etc. The output robot program can be simulated and checked using the Fanuc robot off-line software ROBOGUIDE©. The software also translates the program from ASCII format into binary format that can be executed by the robot.

**Figure 17** Robot path generation process: (a) CAD model; (b) isoline paths; (c) robot simulation; (d) WAAM part (see online version for colours)

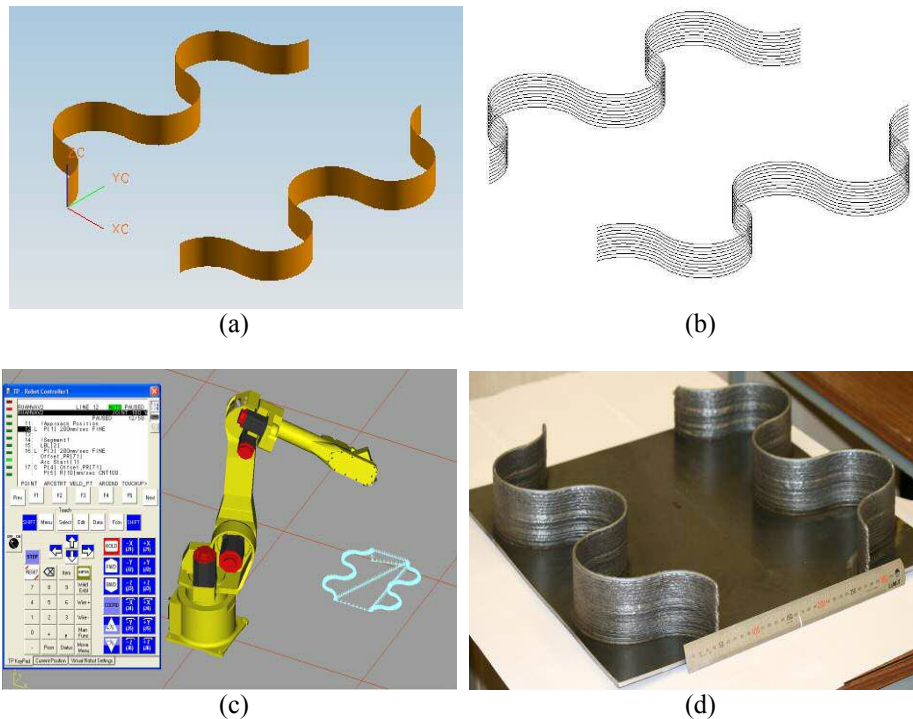

Figure 17 shows the general process of building an AM part from a CAD model. The program first slices the CAD model (Figure 17(a)) from STL data into isoline paths (Figure 17(b)), and then generates the robot program which can be checked in the simulation (Figure 17(c)). Figure 17(d) shows the manufactured AM part using the generated robot program. The total time spent on the robot program generation with is just several minutes. Comparing to the previous experience of using a teach pedant, a huge amount of robot programming time can be saved. Moreover, it also makes building complex three dimensional AM parts possible.

## 6 Conclusions

The WAAM process is an innovative concept that opens a vast space of options for manufacturing large light structures. The WAAM process is especially useful e.g. in manufacturing or repairing parts for aerospace industry where complex light weight structures are required. Due to the high flexibility of the WAAM process, these parts can be tailor made. The arc welding process provides very favourable material properties yielding ready-to-use parts.

The process chain consists of several steps that are feeding into each other. In the Design for WAAM step, new geometries are generated which have been experimentally tested. FE models help understanding and predicting the thermo-mechanical performance of the WAAM process. The gap from CAD design to robotic manufacture of WAAM parts has been closed by an automatic path generation tool. This tool can generate robot paths directly from CAD geometries. Moreover, optimal building parameters and building strategies can be integrated into the robot programme efficiently using this tool.

Future work focuses on investigating the full range of design capabilities and constraints for WAAM and improving the integration of each process step into one single automated smooth process. Sustainability analyses on various industry case studies are part of ongoing research. Minimising the distortions of the WAAM structures and identifying the best building strategies using simulations and systematically designed experiments is also one research focus in the future work.

## Acknowledgements

This research was carried out under RUAM (Ready to Use Additive Manufacturing) project (131) of the IMRC (Innovative Manufacturing Research Centre) Cranfield funded by EPSRC, UK. The authors would like to thank all the RUAM members for their support.

## References

- Almeida, P.M., and Williams, S. 'Innovative process model of Ti-6Al-4V additive layer manufacturing using cold metal transfer (CMT).' Paper Presented at *the Twenty-First Annual International Solid Freeform Fabrication Symposium*. 9-11 August 2010. Austin, America.
- Bernard, A., and Fischer, A. (2002) 'New trends in rapid product development', *CIRP Annals-Manufacturing Technology*, Vol. 51 No. 2, pp. 635-652
- Bernard, A. and Karunakaran, K.P. (2007) 'Rapid manufacturing of metallic objects: a challenge for research and industry', in Bartolo, P. et al (Eds.), *Virtual and rapid manufacturing*, Taylor & Francis Group, London, pp. 7-14.
- Casalino, G. and Ludovico, A.D. (2008) 'Finite element simulation of high speed pulse welding of high specific strength metal alloys', *Journal of Materials Processing Technology*, Vol. 197 No. 1-3, pp. 301-305.
- Chin, R. K., Beuth, J. L. and Amon, C. H. (2001) 'Successive Deposition of Metals in Solid Freeform Fabrication Processes, Part 1: Thermomechanical Models of Layers and Droplet Columns', *Journal of Manufacturing Science and Engineering*, Vol. 123 No. 4, pp. 623-631.
- Chin, R. K., Beuth, J. L. and Amon, C. H. (2001) 'Successive Deposition of Metals in Solid Freeform Fabrication Processes, Part 2: Thermomechanical Models of Adjacent Droplets', *Journal of Manufacturing Science and Engineering*, Vol. 123 No. 4, pp. 632-638.

*Design study for wire and arc additive manufacture*

- Colegrove, P., Ikeagu, C., Thistlethwaite, A., Williams, S., Nagy, T., Suder, W., Steuwer, A., and Pirling, T., (2009) 'Welding Process Impact on Residual Stress and Distortion', *Science and Technology of Welding and Joining*, Vol. 14 No. 9, pp. 717-725.
- Ding, J., Colegrove, P., Mehnen, J., Ganguly, S., Sequeira Almeida, P.M., Wang, F., and Williams, S. (2011) 'Thermo-mechanical analysis of Wire and Arc Additive Layer Manufacturing process on large multi-layer parts', *Computational Materials Science*, Vol. 50 No. 12, pp. 3315-3322.
- Ericsson, M., Nylen, P., Danielsson, F., and Johansson, H. 'Off-Line Programming of Robots for Metal Deposition', Paper Presented at the *7th International Conference on Trends in Welding Research*, 16-20 May 2005. Georgia, America.
- Goldak, J., Chakravarti, A. and Bibby, M. (1984) 'New finite element model for welding heat sources', *Metallurgical Transactions B*, Vol. 15B, pp. 299-305.
- Kazanas, P., Deherkar, P., Almeida, P., Lockett, H. L., and Williams, S. W. (2012) 'Fabrication of geometrical features using wire and arc additive manufacture'. Proceedings of the Institution of Mechanical Engineers, Part B, *Journal of Engineering Manufacture* (accepted for publication)
- Lockett, H., and Kazanas, P. (2009) 'Design for additive layer manufacture', *The Laser User*, Vol. 57, pp. 22-23.
- Mehnen, J., and Trautmann, H., 'Robust Multi-objective Optimisation of Weld Bead Geometry for Additive Manufacturing'. Paper Presented at the *6th CIRP International Seminar on Intelligent Computation in Manufacturing Engineering*. 23-25 July 2008. Naples, Italy.
- Murugan, S., Rai, S.K., Kumar, P.V., Jayakumar, T., Raj, B. and Bose, M.S.C. (2001) 'Temperature distribution and residual stresses due to multipass welding in type 304 stainless steel and low carbon steel weld pads', *International Journal of Pressure Vessels and Piping*, Vol. 78 No. 4, pp. 307-317.
- Mughal, M.P., Mufti, R., and Fawad, H. (2006) 'The mechanical effects of deposition patterns in welding-based layered manufacturing', *Proceeding of the Institution of Mechanical Engineers, Part B: Journal of Engineering Manufacture*, Vol. 221, pp. 1499-1509.
- Nickel, A.H., Barnett, D.M., and Prinz, F.B. (2001) 'Thermal stresses and deposition patterns in layered manufacturing', *Material Science and Engineering A-Structural Materials: Properties, Microstructure and Processing*, Vol. 317, pp. 59-64.
- Ribeiro, A. F. M. (1998) '3D printing with metals', *Computing & Control Engineering Journal*, Vol. 9 No. 1, pp. 31-38.
- Spencer, J.D., Dicken, P.M, and Wykes, C.M. (1998) 'Rapid Prototyping of Metal Parts by Three-Dimensional Welding', *Proceeding of the Institution of Mechanical Engineers, Part B: Journal of Engineering Manufacture*, Vol. 212, pp. 175-182.
- Weiss, L.E., Merz, R., Prinz, F.B., Neplotnik, G., Padmanabhan, P., Schultz, L., and Ramaswami, K. (1997) 'Shape deposition manufacturing of heterogeneous structures', *Journal of Manufacturing Systems*, Vol. 16 No. 4, pp. 239-248.
- Wood, D. (2009) 'Additive Layer manufacturing at Airbus – Real-ity check or view into the future?', *TCT*, Vol. 17 No. 3, pp. 23-27.
- Zhang, Y. M., Li, P., Chen, Y. and Male, A. T. (2002) 'Automated system for welding-based rapid prototyping', *Mechatronics*, Vol. 12 No. 1, pp. 37-53.