



University of HUDDERSFIELD

University of Huddersfield Repository

van Vuuren, Pieter A., Xu, Yuandong, Gu, Fengshou and Ball, Andrew

Monitoring gearbox oil viscosity by means of motor current signal analysis

Original Citation

van Vuuren, Pieter A., Xu, Yuandong, Gu, Fengshou and Ball, Andrew (2017) Monitoring gearbox oil viscosity by means of motor current signal analysis. In: First World Congress on Condition Monitoring - WCCM 2017, 13th-16th June 2017, ILEC Conference Centre, London. (Unpublished)

This version is available at <http://eprints.hud.ac.uk/32266/>

The University Repository is a digital collection of the research output of the University, available on Open Access. Copyright and Moral Rights for the items on this site are retained by the individual author and/or other copyright owners. Users may access full items free of charge; copies of full text items generally can be reproduced, displayed or performed and given to third parties in any format or medium for personal research or study, educational or not-for-profit purposes without prior permission or charge, provided:

- The authors, title and full bibliographic details is credited in any copy;
- A hyperlink and/or URL is included for the original metadata page; and
- The content is not changed in any way.

For more information, including our policy and submission procedure, please contact the Repository Team at: E.mailbox@hud.ac.uk.

<http://eprints.hud.ac.uk/>

Monitoring gearbox oil viscosity by means of motor current signal analysis

Pieter A. van Vuuren

School of Electrical, Electronic and Computer Engineering, North-West University,
Potchefstroom, 2520, South Africa
+27-18 299 1901
pieter.vanvuuren@nwu.ac.za

Yuandong Xu, Fengshou Gu and Andrew D. Ball

Centre for Efficiency and Performance Engineering, University of Huddersfield,
Huddersfield, UK

Abstract

A number of gearbox failures can be attributed to lubricant related problems. One measure of the condition of gearbox oil is its viscosity. In electrically powered systems, motor current signal analysis allows online estimation of the viscosity of gearbox oil without requiring additional sensors. Previous work on this problem entailed monitoring the power (and change in power) of sidebands of the shaft frequency in the induction motor current spectrum. Sideband frequencies in the current spectrum can however be influenced by other potential problems in the electromechanical system ranging from bearing faults to gearbox teeth damage.

Changes in the lubricant viscosity result in changes in the mechanical and thermal losses in the system. These small deviations in the mechanical and thermal losses in the system become visible in the ratio of the electrical energy demanded by the induction motor to the kinetic energy of the rotating mechanical parts. Speed and load invariance can be ensured by normalizing the measured energy ratio with lookup table values obtained when the system attained thermal equilibrium. Speed or load perturbations in the system give rise to small deviations in the normalized energy ratio curve. The distributions of these deviations are significantly different (in a statistical sense) for different oil viscosity values.

1. Introduction

For obvious reasons lubrication plays a vital role in rotating machinery especially in bearings and gearboxes. Consequently, it comes as no surprise that a large proportion of failures in heavy machinery can be attributed to lubrication problems ⁽¹⁾. Monitoring the condition of the lubricant in rotating machinery therefore holds the promise of preventing these failures (as well as the associated costs incurred by the failures) ⁽²⁾.

The properties of lubricating oils are influenced by a number of factors including the presence of foreign contaminant particles (wear debris), water contamination and the viscosity of the oil ⁽²⁾. Oil viscosity is a handy measure of the state of health of a

lubricating oil, since its viscosity has a direct impact on the ability of the oil to minimise friction, bear mechanical load and distribute heat.

It is well known that the viscosity of a fluid is influenced by the chemical composition of the fluid as well as its temperature. During its operational lifetime, lubricating oil is subjected to oxidation reactions which result in an increase in the oil's viscosity ⁽³⁾. The effect of temperature on oil viscosity is both immediate and reversible. Typically an increase in temperature causes a decrease in oil viscosity.

Monitoring the viscosity of lubricating oils is of importance for both the automotive and industrial sectors. More often than not, oil condition is monitored periodically as part of a time-based maintenance strategy. In cases where the prime mover is an internal combustion engine and online condition monitoring is desired, the only recourse is to develop specific sensors to measure the viscosity of the oil. Oil viscosity can be measured by means of metal magnetic memory technology ⁽⁴⁾, ultrasonic techniques ⁽⁵⁾ and vibration methods ⁽⁶⁾. In electromechanical systems the presence of an electrical motor presents the opportunity to utilize the motor both as actuator and sensor.

The field of motor current signal/signature analysis (MCSA) is an established field which has been used to perform condition monitoring on both the electrical motor as well as its load ⁽⁷⁾. In MCSA a variety of spectral analysis techniques are applied to the motor stator current signals in order to detect the state of health of the load. MCSA was also used in previous work to monitor the viscosity of gearbox oil ⁽⁸⁾. In ⁽⁸⁾, the power (and change in power) of specific sidebands of the shaft frequency were used to monitor the gearbox oil. Sideband frequencies in the current spectrum can however be influenced by other potential problems in the electromechanical system ranging from bearing faults ⁽⁹⁾ to gearbox teeth damage ⁽¹⁰⁾.

An alternative approach to monitoring gearbox oil viscosity is to detect subtle changes in the energy balance of the system. Increased oil viscosity results in a slight increase in the damping of the rotating mechanical load. This has a direct impact on the relationship between the electrical energy supplied to the motor, the kinetic energy of the mechanical load as well as the thermal energy dissipated by the gearbox lubricant. The contribution of this paper is therefore a technique to classify the condition of the gearbox oil on the basis of its viscosity by means of the relationship between the system's electrical energy and its kinetic energy.

Section 2 of this paper describes the laboratory setup which was used to obtain data. Thereafter section 3 makes a few general observations from the data which was gathered. A detection algorithm is then developed in section 4, after which the results of the detection procedure are analyzed in section 5. As tradition dictates, the paper is closed off with conclusions and recommendations for future work in section 6.

2. Laboratory setup

The condition monitoring technique presented in this paper originated from practical data obtained in a realistic laboratory test bench ⁽⁸⁾. Consequently the point of departure of the

discussion in this paper is a brief description of the laboratory test bench used to generate the data.

The test bench is a physical model of a typical electromechanical system consisting of a three-phase induction motor connected via one or more gearboxes to a mechanical load. More specifically, the 15kW induction motor is connected by means of flexible spider rubber couplings to two helical gearboxes. Both gearboxes are two-stage industrial gearboxes. Speed reduction is performed by the first gearbox, while the second gearbox is required to increase the shaft speed of the DC generator (which functions as a controllable mechanical load).

Figure 1 shows the main components of the test bench. The lubrication oil of gearbox 1 was changed by means of drainage holes at the bottom of the gearbox. In this manner the mechanical alignment of the system was kept constant throughout the experiment. As shown in figure 1, the system is capable of automated data gathering. The speed of the induction motor is controlled by means of a variable speed drive (VSD) which in turn receives set-points from a computer via a programmable logic controller (PLC). In a similar manner the load torque of the DC generator is controlled by another VSD as indicated in figure 1.

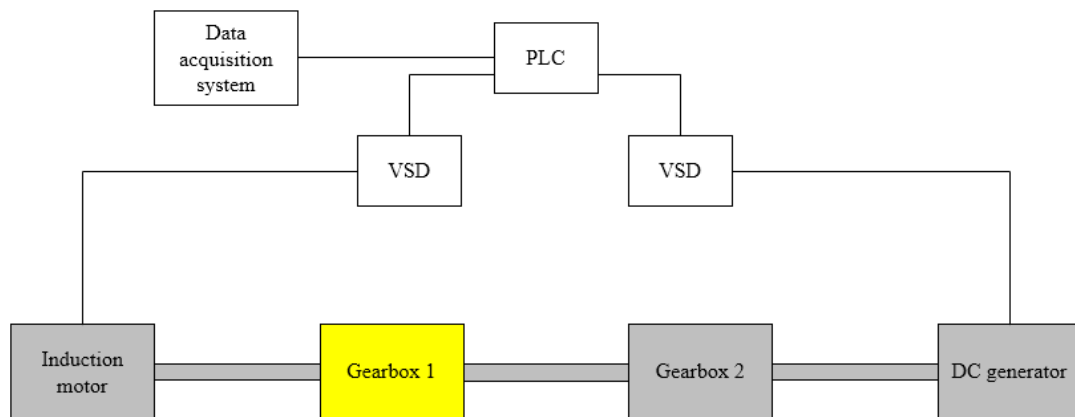

Figure 1. Block diagram of the test bench

The data was gathered in five identical successive tests. Each test entailed four incremental load settings (namely 0%, 30%, 70% and 100% of the gearbox rated load) which was repeated for three different speed settings (namely 100%, 75% and 50% of the full motor speed). Each load and speed setting was applied for two minutes (to allow for transient electrical and mechanical responses to settle), resulting in 24 minutes for each test and 120 minutes in total. The entire procedure was repeated for four different types of gearbox oil labelled EP 100, EP 320, EP 650 and EP 1000. The characteristics of the three oil types that are available commercially are given in table 1. Oil EP 650 was obtained by mixing 39% of EP 100 with 61% of EP 1000. More details on the experimental procedure can be found in ⁽⁸⁾.

Table 1. Characteristics of the oil used in the experiment

Oil designator	Specific gravity (at 15°C)	Kinematic viscosity (at 100°C, c.St)	Kinematic viscosity (at 40°C, c.St)	Viscosity index
EP 100	0.885	10.95	100	93
EP 320	0.901	23.50	320	92
EP 1000	0.927	71.00	1000	140

3. Observations from the measured data

In section 1 it was mentioned that the viscosity of oil is heavily influenced by temperature. This assertion is supported by the results obtained from the test bench. As part of the data gathering process performed in ⁽⁸⁾ the absolute dynamic viscosity of each oil type was measured at different discrete temperatures. These measurements are shown in figure 2. Clearly the oil viscosities reduced as the temperature increased.

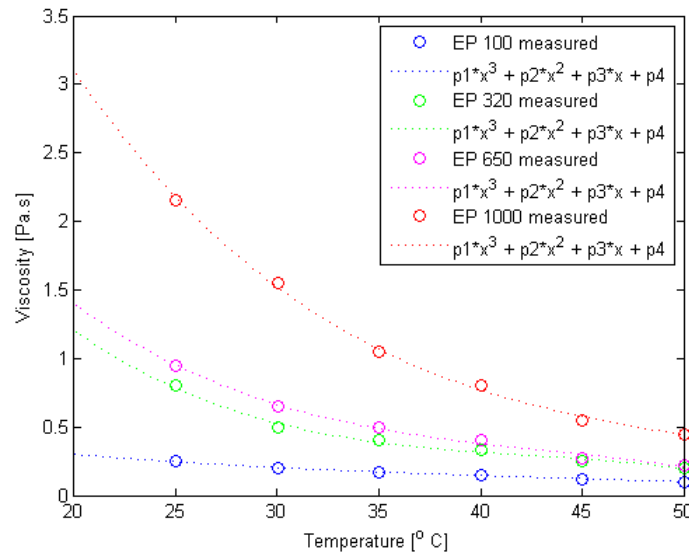

Figure 2. Measured and interpolated oil viscosities as a function of temperature

The temperature of gearbox one was also recorded for each setting during the course of the entire experiment. In order to estimate the changing viscosity of the oil inside gearbox one during the course of the experiment, third order polynomial functions were fitted to the measured viscosity values.

Figure 3 shows the measured oil temperatures as the experiment progressed. Figure 3 also shows the duration of each sub-test and also gives an indication of when the load was varied and when the motor speed was changed.

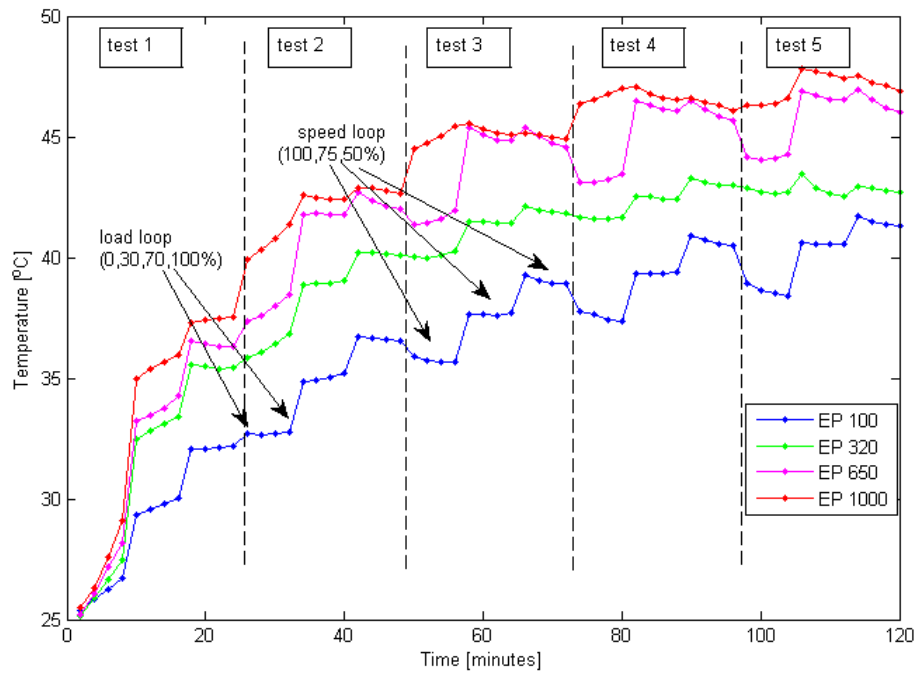

Figure 3. Measured temperature during the course of data gathering

A number of observations can be made from figure 3.

- Changes in motor speed have a large effect on the oil temperature. More specifically, from test 3 onwards it is clear from the EP 100 results that an increase in speed results in a decrease in the gearbox oil temperature.
- Load variation has little effect on the oil temperature. Although small variation in oil temperature can be observed when only the load is changed, the observed temperature variation is primarily due to the transient thermal response of the gearbox oil to a preceding change in motor speed.

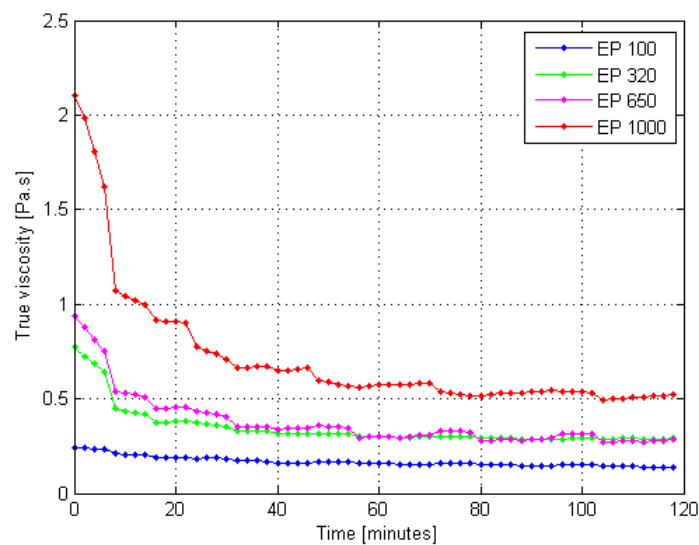

Figure 4. Progression of oil viscosity during the course of data gathering

As one could expect, the effect of temperature variation is clearly visible when the oil viscosity is graphed as a function of time. Figure 4 shows the progression of the oil viscosity as time progressed. The small variations in the oil viscosity correspond to the changes in speed. An important observation from figure 4 is that once the gearbox oil has reached a thermal steady state, it is impossible to distinguish between EP 320 and EP 650 oil.

4. Detection algorithm development

From the observations in section 3 it is clear that it is crucial to monitor the oil temperature as part of an oil condition monitoring strategy. However, one of the reasons for the slow uptake of online condition monitoring techniques by industry is the cost incurred by additional sensors that are required to monitor the said piece of equipment. Even though temperature is a major disturbance variable when it comes to oil viscosity monitoring, a practical condition monitoring system will have to do without a temperature sensor.

Condition monitoring only becomes a viable practical option if the monitoring system is designed to function with sensors that are already available on the equipment to be monitored. The condition monitoring problem therefore becomes even more constrained in that only the variables that are available (namely motor voltages and currents and the estimated motor speed) can be used to monitor the condition of the oil.

We therefore formulate the gearbox oil condition monitoring problem as a classification problem in which the electrical signals and speed of a motor are used to classify the state of the gearbox lubricant in terms of its viscosity. In this paper we distinguish between three classes of oil. Class 1 corresponds to EP 100 oil, while class 2 contains both EP 320 and EP 650. Finally class 3 is reserved for EP 1000 oil.

In a number of industrial applications speed control is applied. Consequently the motor speed signal in itself isn't informative on the condition of the gearbox oil. Changes in gearbox oil viscosity however have an effect on the electrical energy required to maintain a specified motor speed.

Additional insight into the behaviour of the system can be obtained by means of a bond graph model ⁽¹¹⁾. Bond graph models are useful to describe multi-domain systems. In a typical motor-gearbox system energy is exchanged between at least four different domains namely:

- a) electrical to magnetic (in the stator and rotor of an induction motor);
- b) magnetic to rotational mechanical movement (in the interaction between the stator and rotor magnetic fields);
- c) electrical to thermal (due to heating inside the motor);
- d) and rotational mechanical movement to thermal (due to friction and oil viscosity).

A simplified bond graph model of an electrical motor (subject to speed control) which is connected via a massless shaft to a mechanical load (e.g. a mass) is shown in figure 5 ⁽¹²⁾. In this model the constant effort source represents a speed-controlled motor. Since the shaft is regarded as massless it is only modelled as a torsional stiffness element, while the mechanical load is endowed with both stiffness, inertia and damping.

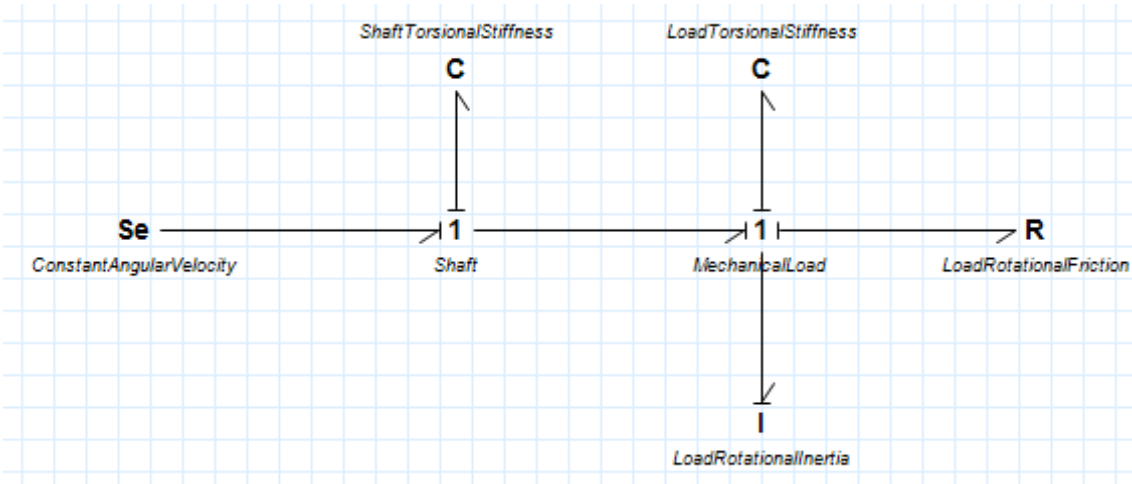

Figure 5. Bond graph model of a motor connected to a mechanical load

The contribution of lubrication oil in this bond graph model is limited to the damping element. The model in figure 5 confirms our intuition that increasing the viscosity of the lubricant will require additional electrical energy, if a constant speed is required.

Our initial hypothesis is therefore that the ratio of the electrical energy required by the motor to the rotational kinetic energy of the load might be sensitive for changes in the viscosity of the gearbox lubricant. The ratio of the total average (or real) electrical energy of the motor to the rotational kinetic energy of the rotating shaft at the input of gearbox 2 is given by:

$$r = \frac{E_{3\phi}}{\frac{1}{2} J_{shaft} \omega^2}, \dots\dots\dots (1)$$

where $E_{3\phi}$ represents the total three phase average electrical energy supplied to the induction motor; J_{shaft} represents the rotational inertia of the rotating mechanical assembly; and ω represents the rotational velocity of the rotating mechanical assembly.

From figure 1 the reader can appreciate that the test bench contains numerous parts rotating at different speeds. Since the objective of equation 1 is to model the thermal losses incurred without explicitly measuring temperature it isn't necessary to derive a detailed model of the rotational components in the system. The kinetic energy of the entire test-bench can therefore be approximated by the kinetic energy of the motor shaft. The implication of the latter simplification is that the energy ratio in (1) will definitely be much larger than unity, but once again the specific value of the energy ratio is irrelevant compared to the *change* in (1) as a function of viscosity variations.

The total three-phase electrical energy of the motor can be obtained by integrating the total real power of the motor over time, which results in the following expression:

$$r = \frac{\int 3V_{\phi} I_{\phi} \cos(\theta) dt}{\frac{1}{2} J_{shaft} \omega^2}, \dots\dots\dots (2)$$

in which V_ϕ and I_ϕ respectively are the motor phase voltage and current and θ represents the power factor angle of the motor. Although (2) isn't an accurate representation of the kinetic energy of the system it is an accurate representation of the ratio between the electrical and kinetic energy of the system. As such, it should be a useful indicator of increased thermal losses due to changes in viscosity.

The energy ratio for the test bench over the course of the experiment is shown in figure 6. As this figure shows, any small variations due to viscosity changes are swamped by the large changes introduced by the effects of speed and load changes.

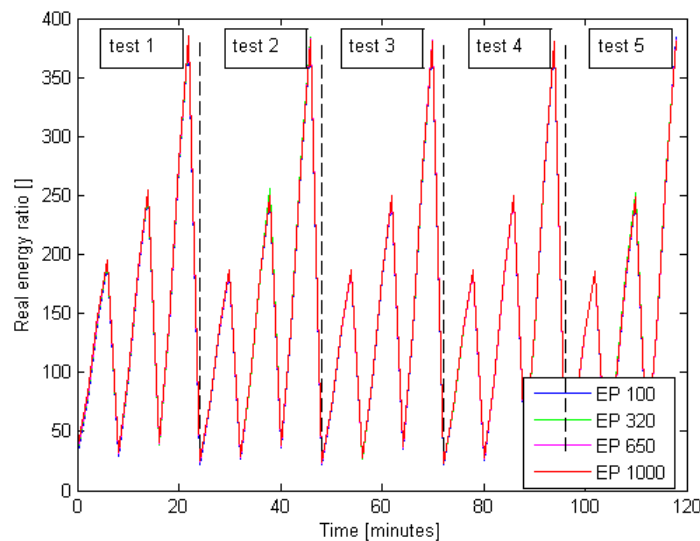

Figure 6. Energy ratio during the course of data gathering

In order to monitor the subtle changes in the energy ratio that are brought about by changes in oil viscosity, it is necessary to compensate for the impact of motor speed and load. This compensation can be performed by normalizing the energy ratio values obtained at a specific speed-load combination with the corresponding energy ratio values measured at thermal steady state. Mathematically, the normalized energy ratio can be expressed as follows:

$$\tilde{r}(\omega, \tau) = \frac{r(\omega, \tau)}{\bar{r}(\omega, \tau)} \dots\dots\dots (3)$$

in which $r(\omega, \tau)$ represents the energy ratio measured at any time instant for a specific motor speed (ω) and load torque (τ). $\bar{r}(\omega, \tau)$ refers to the energy ratio obtained for the same speed and load, but after thermal steady state has been attained.

From figures 3 and 4 one can safely assume that thermal steady state has been attained during test 5 (i.e. the last 24 minutes of the measured data). The energy ratios calculated for EP 100 oil at these last 12 set points are therefore used to normalize the energy ratios for all oil types during the entire measurement period. In this manner any deviations brought upon by changes in oil viscosity become apparent despite variations in load and speed.

Table 2 contains the reference values used for normalization. As an example, if an energy ratio obtained for the motor operating at full speed and no-load has to be normalized, a value of $\bar{r}(\omega, \tau) = 21.6$ is used. Note that EP 100 oil is used as baseline for the normalization of all of the oil types, since in practical situations oil degradation results in an increase in viscosity. Consequently the condition monitoring system only has to monitor for an increase in viscosity.

Table 2. Reference energy ratio values used for normalization

	Load: 0 %	Load: 30 %	Load: 70 %	Load: 100 %
Speed: 50 %	35.4	133.1	271.6	384.3
Speed: 75 %	26.0	90.3	179.1	247.9
Speed: 100 %	21.6	68.9	134.9	185.3

5. Results

The results of normalization of the energy ratio are shown in figure 7. The differences in viscosity as well as changes in viscosity caused by temperature changes are now clear. In the absence of knowledge on the oil temperature or previous load and speed setpoints that have been given to the motor, we are forced to analyse the distributions of the curves in figure 7. These distributions are shown in figure 8. The oil condition monitoring problem now reduces to determining whether the *distribution* of the normalized energy ratio is different for various types of oil.

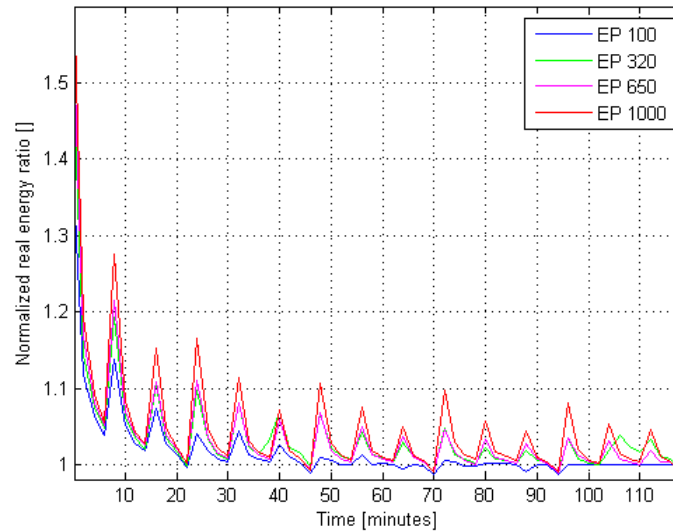

Figure 7. Normalized energy ratio during the course of data gathering

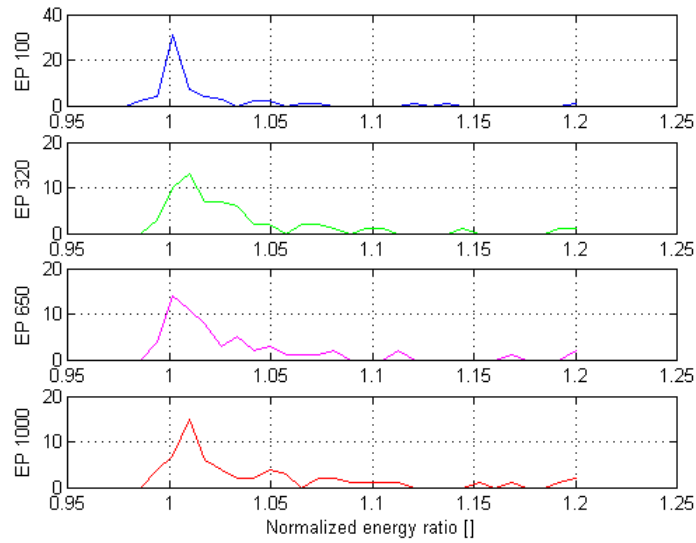

Figure 8. Distributions of the normalized energy ratio

Table 3. Results of the Kolmogorov-Smirnov test applied to pair-wise combinations of the distributions in figure 8

	EP 100	EP 320	EP 650	EP 1000
EP 100	n/a	1	1	1
EP 320		n/a	0	0
EP 650			na	0

Table 3 summarizes the results of formal statistical hypothesis tests that were conducted in order to determine whether there is a statistically significant difference between the various curves in figure 7 (and resultant distributions in figure 8). More specifically the two-sample Kolmogorov-Smirnov test⁽¹³⁾ was applied to determine whether the distributions in figure 8 come from the same underlying distribution. Instances where the nul-hypothesis (namely that two curves originate from the same underlying distribution) is rejected are indicated with a one.

The main conclusion from table 3 is that the curve for EP 100 oil is statistically different from the curves for the other three types of oil. This implies that the normalized energy ratio can be used to differentiate between EP 100 oil and any of the other three types of oil. The normalized energy ratio is however limited in that it can't distinguish between EP 320, EP 650 and EP 1000 oils. This limitation is caused by the values used for normalization - in figure 7 the energy ratio was normalized with the steady-state values for EP 100 oil. Consequently the normalization step emphasized differences between EP 100 oil and the rest.

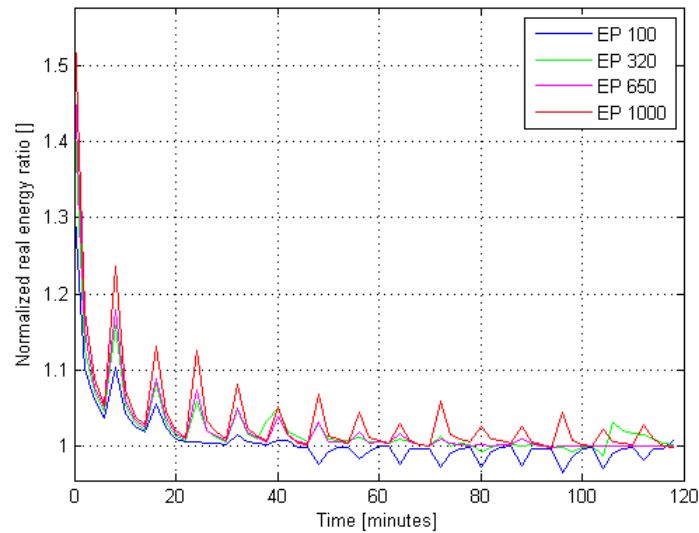

Figure 9. Alternatively normalized energy ratio

Figure 9 show the normalized energy ratio values if the steady state values obtained for EP 650 oil is used as reference values for normalization. It is clear that, especially during the last 60 minutes of the experiment, the three classes of oil (namely EP 100, EP 1000 and intermediate oils) are well separated in terms of their normalized energy ratio values. This observation is supported by formal hypothesis tests as can be seen in table 4. The results in table 3 show that it is in principle possible to distinguish between three classes of oil (EP100, EP 1000 and intermediate oils) on the basis of the normalized energy ratio

Table 4. Results of the Kolmogorov-Smirnov test applied to pair-wise combinations of the underlying distributions in figure 9

	EP 100	EP 320	EP 650	EP 1000
EP 100	n/a	1	1	1
EP 320		n/a	0	0
EP 650			na	1

6. Conclusions

In this paper we presented a technique to classify the condition of the gearbox oil on the basis of its viscosity by means of the relationship between the system's electrical energy and its kinetic energy. We demonstrated that the normalized ratio of the system's electrical energy to its rotational kinetic energy results in distributions that are statistically different for different gearbox oil viscosities. The technique is very simple and relies on measurements that are readily available in an industrial setting. Future work can entail to improve the sensitivity of the technique so that it can detect smaller deviations in viscosity.

References

1. Smith, R and Mobley, R., 'Rules of thumb for maintenance and reliability engineers', New York : Elsevier, 2008.
2. Zhu, X., Du, L. and Zhe, J., 'An integrated lubricant oil conditioning sensor using signal multiplexing', *Journal of Micromechanics and Microengineering*, 2015.
3. Soleimani, M, et al., 'Base oil oxidation detection using novel chemical sensors and impedance spectroscopy measurements', *Sensors and Actuators, B: Chemical*, Vol. 199, pp. 247-258, 2014.
4. Inayatullah, O, et al., 'Monitoring the petrol engine oil viscosity: Investigation of the capability of the metal magnetic memory technology', *Applied Mechanics and Materials*, Vol. 663, pp. 453-458, 2014.
5. Appleby, M, et al., 'Oil debris and viscosity monitoring using ultrasonic and capacitance/inductance measurements', *Lubrication Science*, Vol. 25, pp. 507-524, 2013.
6. Markova, L.V., et al., 'On-line monitoring of the viscosity of lubricating oils', *Journal of Friction and Wear*, Vol. 31, pp. 433-442, 2010.
7. Hedayati, K, Henao, H and Capolino, G.-A., 'Trends in gear fault detection using electrical signature analysis in induction machine-based systems', *IEEE workshop on Electrical Machines Design, Control and Diagnosis (WEMDCD)*, 2015.
8. Abusaad, S, et al., 'The detection of lubricating oil viscosity changes in gearbox transmission systems driven by sensorless variable speed drives using electrical supply parameters', *11th International conference on damage assessment of structures*, 2015.
9. Pinjia, Z and Neti, P., 'Detection of Gearbox Bearing Defects Using Electrical Signature Analysis for Doubly Fed Wind Generators', *IEEE transactions on industry applications*, pp. 2195-2200, 2015.
10. Flores, A, Marques, Cardoso A and Carvalho, J., 'Gearbox fault detection by wavelet and spectrum analysis of the induction motor power', *Proceedings of the 2013 IEEE International Electric Machines and Drives Conference*, 2013.
11. Borutzky, W. *Bond graph methodology: development and analysis of multi-disciplinary dynamic system models*. London : Springer, 2010.
12. Sanchez, R and Medina, A., 'Wind turbine model simulation: a bond graph approach', *Simulation modelling practice and theory*, Vol. 41, pp. 28-45, 2014.
13. Massey, F., 'The Kolmogorov-Smirnov test for goodness of fit', *Journal of the American Statistical Association*, Vol. 46, pp. 68-78, 1951.