



City Research Online

City, University of London Institutional Repository

Citation: Villa-Arango, S., Torres, R., Kyriacou, P. A. & Lucklum, R. (2017). Acoustic spectrometer: Resonant sensing platform for measuring volumetric properties of liquid samples. *IFMBE Proceedings*, 60, pp. 70-73. doi: 10.1007/978-981-10-4086-3_18

This is the accepted version of the paper.

This version of the publication may differ from the final published version.

Permanent repository link: <http://openaccess.city.ac.uk/17559/>

Link to published version: http://dx.doi.org/10.1007/978-981-10-4086-3_18

Copyright and reuse: City Research Online aims to make research outputs of City, University of London available to a wider audience. Copyright and Moral Rights remain with the author(s) and/or copyright holders. URLs from City Research Online may be freely distributed and linked to.

City Research Online:

<http://openaccess.city.ac.uk/>

publications@city.ac.uk

Acoustic spectrometer: resonant sensing platform for measuring volumetric properties of liquid samples

S. Villa-Arango^{1,2}, R. Torres¹, P.A. Kyriacou² and R. Lucklum³

¹ Biomedical Engineering Research Group EIA-CES (GIBEC), EIA University, Envigado, Colombia

² Biomedical Engineering Research Group (BERG), City University London, London, UK

³ Institute of Micro and Sensor Systems (IMOS), Otto-von-Guericke University, Magdeburg, Germany

Abstract— A sensing platform for measuring volumetric properties of liquid samples using phononic crystals is presented in this paper. The proposed sensor concept is based on the transmission of elastic and acoustic waves through solids and liquids respectively to gather relevant information about the properties of the liquid under test. A major difference between this concept and the majority of current resonant sensors, like the well-known quartz crystal microbalance, is that the acoustic spectrometer proposed measures bulk properties and not interfacial properties of the liquid. The sensing platform uses a disposable analyte container to facilitate the measurement of hazardous substances and enable its use in biomedical applications. An electronic characterization system based on the acquisition of three mixed signals was developed to obtain the frequency response of the designed sensor. Finally, experimental and theoretical realizations were performed, using different analytes and showing characteristic transmission features that can be used as measures to determine the physical value speed of sound.

Keywords— Acoustic sensor, liquid sample, biomedical applications, phononic crystals, electronic characterization system.

I. INTRODUCTION

During recent years, there has been a growing interest in sensing platforms based on resonant systems. The perhaps most known is the quartz crystal microbalance, QCM, with a broad application range reaching from film thickness monitor to advanced biosensors which work in liquid environments [1, 2].

Phononic crystals, PnCs, are a new platform that has been proposed to be used in several applications due to their characteristic capacity of generating frequency bands in which elastic waves cannot propagate, giving scientists a way of designing a selective transmission spectrum [3-5]. They have only recently been introduced as sensors and a few research groups have already started performing experimental realizations. [6, 7].

QCM is a resonant sensor with extraordinary (mass) sensitivity. In order to acquire high biochemical sensitivity, it is

necessary to merge the QCM with a biological compound deposited onto the QCM surface that enhances a selective response of the system to the analyte of interest. QCM therefore only measures changes at the interface between the sensor and the analyte, making it impossible to acquire bulk properties of the liquid under test. Unlike the QCM, PnC sensors merge the properties of resonant sensors and ultrasonic sensors by measuring frequency changes of relevant transmission features of ultrasonic waves transmitted through the PnC. The liquid under investigation is confined in a cavity having a well-defined resonance which depends on volumetric properties of a liquid analyte. Similar to QCM, the PnC sensor determines frequency changes of the cavity resonance which appear as a shift in the maximum of transmission and a phase change. PnC sensors are still in a preliminary stage of development, however, a series of structures have been proposed that could be implemented in real sensor applications [6 - 9]. Besides fundamental requirements, real applications may also introduce additional constraints, specifically in biosensing [10, 12].

Commercial electronic characterization systems that are commonly used to measure the characteristic frequency features of resonant structures are vector network analyzers and high-frequency lock-in amplifiers. These conventional systems are very robust and expensive, making it very challenging to conduct tests in the field, thus, forcing the users to send the samples to specialized laboratories and, therefore, limiting the applicability of these sensing systems in various areas. However, a novel characterization system for measuring frequency changes of resonant structures like PnC has recently been introduced. This system is based on a double sideband modulation with suppressed carrier and a special demodulation process that involves a series of operations to obtain a signal that depends both on changes in the amplitude and phase induced by the resonant system under test. It enables, therefore, the use of phononic crystals in the field due to its portability [12].

The block diagram of the electronic system can be observed in Fig. 1.

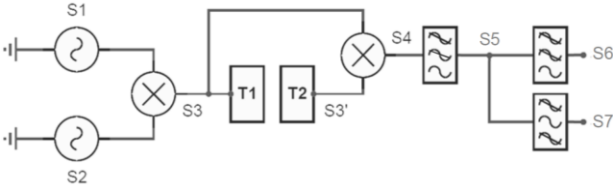

Fig. 1 Block diagram of the electronic characterization with a double sideband modulation. Source: [12].

A resonant sensing platform that measures volumetric properties of liquid analytes in a disposable container using an electronic characterization system based on the double sideband modulation system is presented on this paper. The approach used relies on the measurement of both gain and frequency of relevant transmission features present in frequencies in the order of MHz.

II. MATERIALS AND METHODS

Biomedical applications often require the use of biological or hazardous samples and, therefore, it is important to take into account that all the elements of the system that are in contact with the analyte must be disinfected or discarded after the test is completed. The acoustic spectrometer designed has three main components: An electronic characterization system, a pair of piezoelectric ultrasonic transducers and a disposable analyte container made of glass that can be discarded or sterilized after each test. Fig. 2 shows a graphic representation of the container and the analyte, which can be understood as the very simple 1-D PnC. The ultrasonic waves travel from one transducer to the other generating a cavity resonance inside the container.

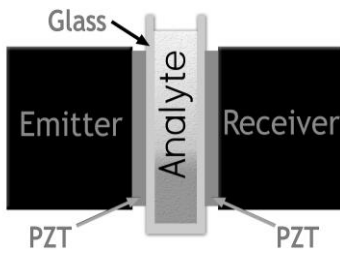

Fig. 2 Graphic representation of the acoustic spectrometer structure.

The electronic characterization system is based on obtaining three main signals, these signals are acquired by using the excitation signal that is fed to the transducer configured as the transmitter, S_0 , and the signal acquired by the transducer configured as the receiver, S_1 , same as in the system presented in Fig. 1, but without the double sideband modulation.

The three signals that the system obtains are: the square of the RMS value of S_0 , the square of the RMS value of S_1 , and the DC component of the signal obtained by multiplying S_0 by S_1 . The signals are then passed through a series of mathematical operations to acquire the gain and phase of the system, thus generating a frequency spectrum with valuable information on the volumetric properties of the substance being analyzed. The block diagram of the proposed system is shown in Fig. 3.

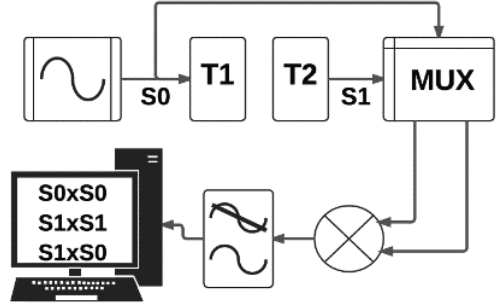

Fig. 3 Block diagram of the electronic characterization system designed.

As seen in the block diagram, Fig. 3, an analog multiplexer feeds a four quadrant multiplier with the two signals, S_0 and S_1 , to perform three multiplications and to obtain 3 mixed signals, S_2 , S_3 and S_4 . The signal acquired by the receiver, S_1 , experiences modifications when traveling through the resonant structure and the ultrasonic transducers. These variations are presented as changes in gain, G , and changes in phase φ_2 .

$$S_0(t) = A \sin(2\pi ft + \varphi); S_1(t) = AG \sin(2\pi ft + \varphi + \varphi_2) \quad (1)$$

$$S_2(t) = A^2 \sin^2(2\pi ft + \varphi) \quad (2)$$

$$S_3(t) = A^2 G^2 \sin^2(2\pi ft + \varphi + \varphi_2) \quad (3)$$

$$S_4(t) = (A^2 G^2 / 2) [\cos(\varphi_2 - \varphi) - \cos(4\pi ft + \varphi_2 + \varphi)] \quad (4)$$

The three mixed signals obtained by performing the multiplication between S_0 and S_1 are then passed through a low-pass frequency filter to obtain the DC component of each signal. The resulting signals are then passed through a digital to analog converter to be processed by a microcontroller.

$$S'_2(t) = A^2 / 2 \quad (5)$$

$$S'_3(t) = A^2 G^2 / 2 \quad (6)$$

$$S'_4(t) = (A^2 G / 2) \cos(\varphi_2 - \varphi) \quad (7)$$

The three signals obtained contain relevant information to extract the value of the gain, G , and phase, φ , of the system. The gain is obtained by calculating the square root of the resulting value of dividing S'_3 by S'_2 , while the phase is obtained by calculating the inverse cosine of the resulting value of dividing S'_4 by G and S'_2 .

$$G(t) = \sqrt{(A^2 G^2 / 2) / (A^2 / 2)} \quad (8)$$

$$\varphi(t) = \cos^{-1} \left(\frac{A^2 G}{2} \cos(\varphi_2 - \varphi) / G \frac{A^2}{2} \right) \quad (9)$$

For the experimental realizations, wide bandwidth piezoelectric ultrasonic transducers with a central frequency of 1.5MHz and a half-peak band width of 1 MHz were used.

The electronic system was set to acquire a total of 400 points starting at 0.85MHz, with frequency steps of 3 kHz and ending at 2.05MHz. The disposable analyte container used was a 700uL glass cuvette and only 500uL of analyte were used per test. The cuvette was carefully rinsed and dried using acetone before introducing a new sample and the temperature was kept constant via room temperature control.

The ultrasonic transducers were coupled to the analyte container using glycerol and a holding structure specially designed to ensure an adequate surface contact and constant pressure. The experimental arrangement of the acoustic spectrometer can be observed in Fig. 4.

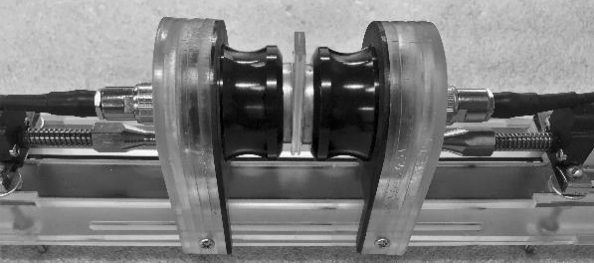

Fig. 4 Acoustic spectrometer experimental arrangement.

To evaluate the performance of the acoustic spectrometer, tests using different alcohol analytes were conducted. The properties of the analytes used can be found in Table 1. There are many methods to simulate phononic crystal structures, some of them are the Layer Multiple Scattering Theory (LMST), the Finite difference Time Domain (FDTD), the Finite Element Analysis (FEA) and the 1D Transmission Line Model (TLM). Simulations using the 1D Transmission Line Model to corroborate the experimental results were performed. This method was selected because it is widely used to simulate the performance of multilayered structures giving accurate results and it uses a reduction of the model to 1D that enhances the calculation speed and lowers the computation power required, that are commonly high when other methodologies are used. The TLM uses a chain matrix technique and an analogy between the electrical impedance and the acoustic impedance to perform the calculation of the transmission and reflection coefficients. The geometric and material properties of each layer were used to calculate the elements of the propagation matrix [10 - 14].

Table 1 Analytes used for the preliminary tests

Analyte	Density kg/m ³	Speed of sound m/s
Distilled Water	998	1493
n-Propanol	786	1170
Methanol	792	1100

Source: Adapted from [15]

III. RESULTS AND DISCUSSION

The results obtained from the experimental realizations conducted are shown in Fig. 5. No further digital signal processing was made to enhance the quality of the signals given the signal to noise ratio exhibited by the electronic system.

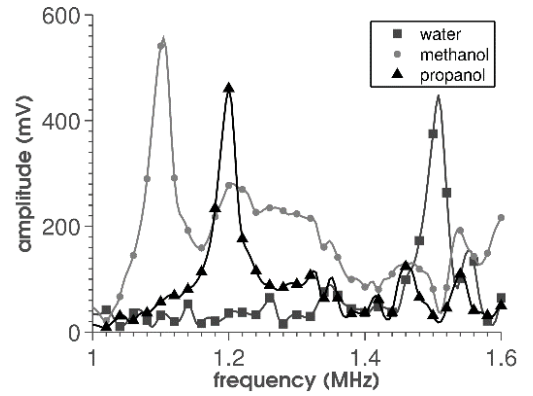

Fig. 5 Experimental results using different alcohols as analytes.

Each test showed a well differentiated maximum of transmission generated by the resonance in the cavity. This characteristic transmission feature has a good quality factor and was located at different frequencies on each experimental realization. The results from the simulations using the 1D transmission line model are shown in Fig. 6.

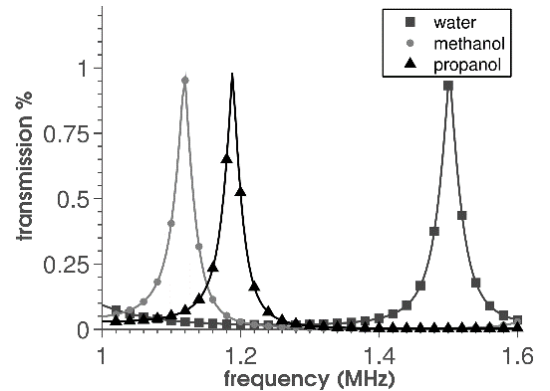

Fig. 6 Theoretical results using different alcohols as analytes.

The transmission curves obtained in both theoretical and experimental realizations show significant changes in the frequency and magnitude of the main resonant peaks. Variations in the acoustic properties of the liquid mixtures showed to be responsible of the frequency changes on the characteristic transmission features. The maxima of transmission of the experimental realizations agree well with the ones obtained in the simulations.

The sensitivity obtained in these tests is very promising, variations of 1 m/s-1 on the longitudinal component of the speed of sound of the analyte produce variations of 1098 Hz in the frequency of the characteristic transmission peaks. This result is very important given the fact that the signal to noise ratio of the system is high and enables accurate measurements of the frequency of the transmission features without noise interference.

IV. CONCLUSIONS

An acoustic spectrometer with a disposable cavity that measures volumetric properties of liquid analytes was studied in this manuscript. The acoustic spectrometer relies on the determination of the frequency of relevant transmission features, in this case, maximums of transmission. The 1D transmission line model showed to be useful to corroborate and even predict the results obtained with the system.

The removable component of the sensing platform enables its use in applications where hazardous substances need to be analyzed, like point of care testing and other biomedical applications.

The electronic characterization system designed is portable and economic and makes it possible to use the acoustic spectrometer in the field. The designed platform could differentiate two different alcohols and distilled water with sufficient sensitivity and resolution, however, in order to use the designed system in label free applications with extraordinary sensitivity and lower analyte availability, further optimization processes need to be done, like using much higher frequencies to enhance sensitivity and using a smaller analyte container to lower analyte consumption.

On-going investigations deal with making the acoustic spectrometer an absolute sensor, which can effectively differentiate target analytes without the need of a reference transmission spectrum by means of including a biological compound to the analyte container that enhances the sensitivity and selectivity of the system, like it is done with QCM biosensors. [2]

CONFLICT OF INTEREST

The authors declare that they have no conflict of interest.

REFERENCES

1. Arnau A (2008) *Piezoelectric Transducers and Applications* (2-ed.). Berlin: Springer, ISBN: 978-3-540-77507-2
2. Montagut Y, Narbon J G, Jimenez Y, March C, Montoya A, Arnau A, Serra P A (2011) QCM Technology in Biosensors. *Biosensors - Emerging Materials and Applications*, pp. 153-178. DOI: 10.5772/17991
3. Pennec Y, Vasseur J O, Djafari-Rouhani B, Dobrzyński L, Deymier P A (2010) Two-dimensional phononic crystals: Examples and applications. *Surface Science Reports* 65, pp. 229–291, DOI:10.1016/j.surfrep.2010.08.002
4. Sigalas M M, Economou E N (1992) Elastic and acoustic wave band structure, *J. Sound Vibr.* 158, pp. 377-382, DOI: 10.1016/0022-460X(92)90059-7
5. Kushwaha M S, Halevi P, Martinez G, Dobrzyński L, Djafari-Rouhani B (1993) Acoustic Band Structure of Periodic Elastic Composites, *Phys. Rev. Lett.* 71, 2022
6. Lucklum R, Li J (2009) Phononic crystals for liquid sensor applications, *Meas. Sci. Technol.* 20, 124014 (12pp). DOI:10.1088/0957-0233/20/12/124014
7. Jyun-Hong L, Dong-Po C, Cheng-Yi H, Fu-Li H, Chii-Chang C (2015) Liquid sensor composed of one-dimensional sonic Helmholtz resonator array. *Appl. Phys. A.* 120, pp. 509–517, DOI: 10.1007/s00339-015-9203-3
8. Lucklum R, Ke M, Zubtsov M (2012) Two-dimensional phononic crystal sensor based on a cavity mode. *Sensors and Actuators B.* 171–172, pp. 271–277, DOI: 10.1016/j.snb.2012.03.063
9. Ke M, Zubtsov M, and Lucklum R (2011) Sub-wavelength phononic crystal liquid sensor. *J. Appl. Phys.* 110, 026101. DOI: 10.1063/1.3610391
10. Lucklum R, Villa S, Zubtsov M (2014) Cavity resonance biomedical sensor, IMECE2014-38222: ASME 2014 International Mechanical Engineering Congress and Exposition, 2014, Montreal, Quebec, Canada. ISBN: 978-0-7918-4962-0
11. Lucklum R, Villa S, Zubtsov M, Grundmann R (2014) Phononic crystal sensor for medical applications. *IEEE SENSORS 2014*, Valencia, Spain, pp. 903 - 906. DOI: 10.1109
12. Villa S, Torres R, Lucklum R (2015) Electronic characterisation system for measuring frequency changes in phononic crystals. *Electronics Letters*, Volume 51, Issue 7, pp. 545-546. DOI: 10.1049/el.2014.4151.
13. Qiu C, Liu Z, Mei J, Ke M (2005) The layer multiple-scattering method for calculating transmission coefficients of 2D phononic crystals. *Solid State Communications*, 134, pp. 765-770.
14. Tanaka Y, Tomoyasu Y, Tamura I (2000) Band structures of acoustic waves in phononic lattices: Two-dimensional composites with large acoustic mismatch. *Phys. Rev. B* 62, pp. 7387-7392.
15. Kuhnies R, Schaaffs W (1963) Untersuchungen an adiabatisch und isotherm aufgenommenen Schallkennlinien binärer Mischungen, *Acustica* 13, 407.

Author: Simón Villa Arango

Institute: EIA University

Street: Calle 25 Sur 42-73

City: Envigado

Country: Colombia

Email: simon.villa@eia.edu.co