

Lukas Soellner<sup>1</sup>, Matthias Begemann<sup>1</sup>, Deborah JG Mackay<sup>2</sup>, Karen Grønskov<sup>3</sup>, Zeynep Tümer<sup>3</sup>, Eamonn R Maher<sup>4</sup>, I. Karen Temple<sup>2</sup>, David Monk<sup>5</sup>, Andrea Riccio<sup>6</sup>, Agnès Linglart<sup>7</sup>, Irène Netchine<sup>8</sup>, Thomas Eggermann<sup>1</sup>

<sup>1</sup> Department of Human Genetics, RWTH Aachen, Aachen, Germany

<sup>2</sup> Human Genetics and Genomic Medicine, Faculty of Medicine University of Southampton Wessex Clinical Genetics Service, Princess Anne Hospital, Coxford Road, Southampton, United Kingdom

<sup>3</sup> Clinical Genetic Clinic, Kennedy Center, Rigshospitalet, Copenhagen University Hospital, Glostrup, Denmark

<sup>4</sup> Department of Medical Genetics, University of Cambridge and NIHR Cambridge Biomedical Research Centre, Cambridge, United Kingdom

<sup>5</sup> Imprinting and Cancer Group, Cancer Epigenetic and Biology Program (PEBC), Institut d'Investigació Biomedica de Bellvitge (IDIBELL), Hospital Duran i Reynals, Barcelona, Spain

<sup>6</sup> DiSTABiF, Seconda Università degli Studi di Napoli, Caserta; Institute of Genetics and Biophysics – ABT, CNR, Napoli, Italy

<sup>7</sup> Endocrinology and diabetology for children and reference center for rare disorders of calcium and phosphorus metabolism, Bicêtre Paris Sud, APHP; INSERM U986, INSERM; Le Kremlin-Bicêtre, France

<sup>8</sup> INSERM, UMR\_S 938, CDR Saint-Antoine, Paris F-75012, France; Sorbonne Universites, UPMC Univ Paris 06, UMR\_S 938, CDR Saint-Antoine, Paris, France; 3APHP, Armand Trousseau Hospital, Pediatric Endocrinology, Paris, France

**Corresponding author:**

Thomas Eggermann,  
Institute of Human Genetics,  
University Hospital, RWTH Aachen,  
Pauwelsstr. 30,  
Phone: +49 241 8088008,  
Fax: +49 241 8082394,  
Email: teggermann@ukaachen.de

**Conflict of interest statement:**

The authors declare that they have no conflict of interest.

**Acknowledgement**

All authors are members of the COST Action BM1208 and EUCID.net (European congenital imprinting disorders network; [www.imprinting-disorders.eu](http://www.imprinting-disorders.eu)). TE is supported by the Bundesministerium für Bildung und Forschung (Network “Imprinting Diseases”, 01GM1513B).

This article has been accepted for publication and undergone full peer review but has not been through the copyediting, typesetting, pagination and proofreading process, which may lead to differences between this version and the Version of Record. Please cite this article as doi: 10.1111/cge.12827

**Abstract**

Imprinting disorders (ImpDis) are a group of currently twelve congenital diseases with common underlying (epi)genetic aetiologies and overlapping clinical features affecting growth, development and metabolism. In the last years it has emerged that ms are characterized by the same types of mutations and epimutations, i.e. uniparental disomies, copy number variations, epimutations, and point mutations. Each ImpDis is associated with a specific imprinted locus, but the same imprinted region can be involved in different ImpDis. Additionally, even the same aberrant methylation patterns are observed in different phenotypes. As some ImpDis share clinical features, clinical diagnosis is difficult in some cases. The advances in molecular and clinical diagnosis of ImpDis help to circumvent these issues, and they are accompanied by an increasing understanding of the pathomechanism behind them. As these mechanisms have important roles for the etiology of other common conditions, the results in ImpDis research have a wider effect beyond the borders of ImpDis. For patients and their families, the growing knowledge contributes to a more directed genetic counselling of the families and personalized therapeutic approaches.

**Key-words:** Imprinting Disorder – epigenetic regulation – imprinted genes network – uniparental disomy

**Abbreviations:**

CNV – copy number variation  
DMR – differentially methylated region  
ImDis – imprinting disorder  
IGN – imprinted genes network  
IUGR – intrauterine growth retardation  
MZ - monozygotic  
PNGR – postnatal growth retardation  
SNP – single nucleotide polymorphisms  
TF – transcription factor  
UPD – uniparental disomy

## Introduction

Imprinting disorders (ImpDis) are a group of congenital disorders caused by common types of alterations affecting imprinted genes or chromosomal regions. Though the pathophysiological mechanisms are unclear for the majority of ImpDis associated features, it is generally accepted that they all lead to an imbalance of the fine-tuned expression of genes regulated by differentially methylated regions (DMRs) in imprinted chromosomal regions. The molecular changes are heterogeneous in several ImpDis (table 1), and not only comprise different types of alterations at the same locus, but also different loci and/or chromosomes can be affected in the same ImpDis.

The molecular pathology in ImpDis comprises genomic as well as epigenetic changes (figure 1). In contrast to the majority of biallelically expressed genes, imprinted genes are expressed monoallelically and dependent from the parental origin of the allele, i.e. either the maternal or the paternal allele is expressed. At the molecular level, the expression of genes within imprinted regions is influenced by methylation of CpG residues in the genomic DNA (organised in differentially methylated regions – DMRs), interference with non-coding RNAs (ncRNAs), changes in chromatin structure, and post-translational histone modifications. So far, more than 90 imprinted human genes have been identified, but there are probably more (for review: <http://www.geneimprint.com/site/home>, last check: April 2016). The epigenetic signature of the human genome is inherited from the parental gametes and is then maintained in the majority of somatic cells and tissues of an individual. Genomic imprinting marks are exempted from the general developmental reprogramming of methylation marking; instead, they are erased in the germ-line and re-established according to the sex of the contributing parent for the next generation. Many genes regulated by genomic imprinting are found in clusters, i.e. imprinted loci often comprise multiple genes under a coordinated control.

## Clinical Pictures

To date, twelve ImpDis have been defined (table 1) based on distinct clinical findings and/or an association with molecular disturbances at specific imprinted loci. The majority of ImpDis show features belonging to common clinical groups, i.e.:

- aberrant pre- and/or postnatal growth,
- hypo- or hyperglycemia,
- abnormal feeding behavior in early childhood and later,
- behavioural difficulties, mental retardation,
- precocious puberty.

However, the distinction between the different ImpDis becomes sometimes difficult due to common phenotypic signs and overlapping molecular alterations (1), which can pose problems for accurate diagnosis in some patients. Clinical scoring systems are available for some ImpDis (table 2), and define typical phenotypic features for these disorders, but might fail to detect those patients with only minor or atypical clinical signs. Furthermore, even the cases satisfying the clinical diagnostic criteria for a specific ImpDis can carry a molecular change typically associated with another ImpDis.

Nearly all ImpDis patients are diagnosed in (early) childhood. However, clinical diagnosis is often hampered by the breadth of the phenotypic features which are sometimes subtle, overlapping and transient. The latter can obscure diagnosis in puberty and adulthood. As a consequence, an unknown number of ImpDis patients are probably either mis- or undiagnosed. Additionally, the clinical ambiguity can make the decision of the applicable test difficult.

## Common molecular alterations

So far, four different types of molecular changes have been shown to be associated with ImpDis, (i) copy number variations (CNVs: deletions, duplications) of the imprinted region, (ii) uniparental disomy (UPD), (iii) aberrant methylation marks (“epimutations”), and (iv) point mutations in (imprinted) genes. With the exception of point mutations which directly affect the function of the relevant gene product, the functional relevance of these changes can only be estimated: as mentioned before, they probably affect the finely-balanced expression of imprinted factors, but the detailed pathophysiology is not yet established for the majority of disorders.

(i) CNVs were the first alterations detected in ImpDis and are extremely valuable to identify and delineate the genomic regions of imprinted factors and regions. The first examples were 15q deletions affecting either the maternally or paternally inherited allele in Angelman and Prader-Willi syndromes, respectively (2). The significance of CNVs of different sizes to understand the hierarchical regulation of DMRs in the same chromosomal region is illustrated by the *MEG3* and IG-DMRs in 14q32, where the IG-DMR is dominant over the *MEG3* DMR (3, 4). After identification of imprinted genomic regions, the detailed characterization of small CNVs therein contributes to the identification of sequences involved in the setting of imprinting marks (e.g. (5)).

(ii) The second class of mutations typically associated with ImpDis is uniparental disomies (UPD), i.e. the inheritance of both chromosomes/chromosomal regions of a pair from only one parent (6). The first UPD reported in human was a *upd(7)mat* in a Cystic Fibrosis patient with an unexpected homozygosity for an autosomal-recessive *CFTR* mutation (7). The patient also exhibited clinical features of Silver-Russell syndrome (SRS), but the link between *upd(7)mat* and SRS was not established until 1995 (8). The first association between UPD of an imprinted region and a specific phenotype was published in 1989 for Prader-Willi syndrome (2).

The first reports on UPD illustrated the two subtypes of UPD. *Upd(7)mat* is an example of uniparental isodisomy (UPiD), i.e. two identical copies of the same chromosome have been inherited; homozygosity for an autosomal-recessively inherited disorders can result, as in the case of Spence et al. (7). The other UPD subtype is uniparental heterodisomy (UPhD), i.e. inheritance of both chromosomes from the same parent. Different modes of UPD formation have been postulated, all resulting from meiotic and/or mitotic nondisjunction mechanisms (for review: (8)). The major mode of UPD formation is trisomic rescue, which mainly results in UPhD of the whole chromosome or a mixed UPhD/UPiD. In contrast, pure UPiD is often caused by postzygotic nondisjunction. Both UPiD and UPhD result in the same pathophysiological effects when they affect the expression of imprinted genes. Indeed, with the exception of the central precocious puberty-2, Schaaf-Yang syndrome and Birk-Barel mental retardation, UPD has been identified in all ImpDis. The contribution of UPD to the mutation spectrum in ImpDis ranges between 1% (in Angelman syndrome, AS) and nearly 80% (in Temple syndrome, TS14). UPDs contribute to the identification of imprinted chromosomes, but in contrast to CNVs affecting imprinted genes, UPD often comprise whole chromosomes or large segments (“segmental UPD”) and therefore they have not been helpful for the identification of imprinted genes or regions.

(iii) The term “epimutation” describes an aberrant DNA methylation or histone modification pattern at a DMR without a disturbance of the genomic DNA sequence at the respective DMR. Primary epimutations are defined as isolated alterations of an imprinting mark, without any obvious associated DNA sequence alteration, whereas secondary epimutations are the

result of a DNA sequence change outside the DMR (for review: (9)). In BWS primary epimutations at the ICR2 DMR have been associated with the use of assisted reproductive technologies (10). There is a growing number of reports on genomic mutations which cause secondary epimutations at an imprinted locus. These genomic variants comprise both CNVs or point mutations in direct neighborhood to the DMR (cis acting) as well as variants in other chromosomal regions (trans acting) (figure 2).

iv) Point mutations in protein-coding genes have been reported only in five of the 10 known ImpDis; with exception of central precocious puberty-2 (PPS2) and Birk-Barel mental retardation they account only for a small number of patients or single cases (table 1). It should be noted that they are the only class of variants in ImpDis which likely directly cause characteristic features. Nevertheless, even in this group of molecular defects the pathogenetic mechanisms are not yet understood.

### **Peculiarities in genetics of Imprinting Disorders**

Imprinting disorders are genetically caused syndromes, but show several differences in comparison to classical Mendelian inherited diseases.

When familial, inheritance of CNVs and point mutations is usually autosomal dominant, but the penetrance of the mutation depends on the sex of the parent contributing the molecular alterations. Typical examples are *MKRN3*, *MAGEL2*, *KCNK9*, *UBE3A*, *CDKN1C* and *IGF2* mutations which result in a pathological phenotype only if the active maternal or paternal allele is affected. Genetic counselling becomes even more complex in case of chromosomal translocations predisposing to a deletion or duplication of an imprinted region because different ImpDis can be expected. Additionally, this situation can be complicated by the (theoretical) risk of UPD formation (e.g. (11)).

A further common molecular finding in some ImpDis is mosaicism. It is observed in patients carrying UPiD and epimutations, and can be explained by the mainly post-zygotic origin of these changes. Mosaicism can obscure genotype-phenotype correlation, and can significantly hamper the detection and diagnosis of both disturbances.

The third ImpDis-specific observation is discordant monozygotic (DMZ) twinning, which has particularly been reported in BWS (for review (12)). This discordance is remarkable because MZ twins derive from the same zygote and are therefore genetically identical. However, it may be regarded as a phenomenon related to epigenetic mosaicism: an early embryo with marked mosaicism between different cells may develop into a single mosaic individual, or if the embryo fragments, it may develop into monozygotic twins with different degrees of epimutation. The frequency of DMZ twinning is several-fold higher in cases of BWS, TNDM and MLID (see below) than in the general population (12-14). It is currently unclear whether hypomethylation predisposes to DMZ twinning or vice versa. Interestingly, there is a considerable preponderance of females among the MZ twins with BWS, and a functional link between altered imprinting and X chromosome inactivation has been suggested (15).

### **Advances in Imprinting Disorders I: Identification of new Disorders**

Whereas Prader-Willi, Angelman, Beckwith-Wiedemann and Silver-Russell syndromes, transient diabetes mellitus, and pseudohypoparathyroidism Ib (PWS, AS, BWS, SRS, TNDM and PHPIb) are well known as ImpDis, five further ImpDis have been defined recently and will be overviewed in the following paragraph (table 1).

Two of the new syndromes are associated with the chromosomal region 14q32, and were firstly described as upd(14)mat and upd(14)pat syndromes. More recently, additional molecular changes have been reported, and therefore the names **Temple syndrome** (TS14) for upd(14)mat and **Kagami-Ogata syndrome** (KOS14) for upd(14)pat have been proposed (1, 4). In both syndromes at least two DMRs are involved (*MEG3/DLK1*:IG-DMR and *MEG3*:TSS-DMR), and the role of a third has been proposed (16). TS14 and KOS14 result from opposing molecular changes –effectively maternalisation and paternalisation respectively – at the chr14 DMRs. Pairs of syndromes caused by opposing molecular changes are also seen at 15q11q13 in PWS/AS and 11p15.5 in SRS/BWS. For TS14, the role of an altered *RTL1* and *DLK1* expression has been suggested (4). In case of Kagami-Ogata syndrome it has been postulated that the increased expression of *RTL1* regulated by the *MEG3/DLK1*:IG-DMR is responsible for the clinical outcome, whereas a role of *DLK1* can be discounted (4). The expression of these genes is hierarchical and primarily regulated by the *MEG3/DLK1*:IG-DMR, whereas the *MEG3*:TSS-DMR is subordinate (3, 4).

Mutations in *KCNK9* (8q24.3) have been reported in individuals with **Birk-Barel mental retardation** (17) with the phenotype manifesting only after maternal transmission, consistent with the gene's imprinting status (18). This disorder is associated with moderate to severe intellectual disability, hyperactivity, feeding difficulties, hypotonia at an early age and a semi-characteristic elongated face. However screening individuals with autism-spectrum disorder, a disease genetically linked to the proximal 8q locus (19), or in individuals with more specific overlapping cognitive features failed to identify additional *KCNK9* mutations or constitutive methylation defects of nearby *PEG13* DMR (20). Together this suggests that the maternally-inherited *KCNK9* mutations cause the phenotype through a dominant-negative effect with other potassium channel proteins in the brain.

**Central precocious puberty 2** (CPP2) has recently been identified as an isolated feature caused by genomic variants in the Makorin ring finger 3 (*MKRN3*) gene (21-24): Consistent with the *MKRN3* imprinting status the phenotype is only present in case of paternal transmission of the mutation. Mutations in *MKRN3* have been shown to be the most frequent cause of familial CPP and they have also been detected in nearly 4% in a cohort of 215 non-familial idiopathic CCP (21). The *MKRN3* gene (also known as *ZNF127*) is an intronless transcript located on chromosome 15q11.2 in the PWS critical region, encoding a protein with C3H zinc-finger and RING zinc-finger motifs. In contrast to the broad molecular spectrum associated with other ImpDis, genomic point mutations of *MKRN3* are currently the only type of variants associated with CPP2.

The same chromosomal region is associated with another recently suggested ImpDis, the **Schaaf-Yang syndrome** (SHFYNG)(25). The disorder is caused by heterozygous mutations in the *MAGEL2* gene which occur on the paternal allele. Clinically, the phenotype resembles PWS.

**Maternal uniparental disomy of chromosome 20 (upd(20)mat)** has been reported in twelve patients (26), three of whom also had mosaicism for complete or partial trisomy of chromosome 20. So far, other types of molecular alterations have not been described, and a candidate region on chromosome 20 is currently unknown. The prevalence of upd(20)mat is currently unknown; one reason is probably the lack of specificity of its major clinical features, i.e. failure to thrive and intrauterine/postnatal growth retardation. In particular, dysmorphisms, congenital abnormalities or major developmental delay have not yet been reported that might contribute to a further clinical definition of the disorder. Upd(20)mat has been identified in single patients referred with features of SRS or TS14; thus these cohorts may contain other individuals with upd(20)mat as a significant phenotypic overlap exists.

## Advances in Imprinting Disorders II: Towards an understanding of the pathomechanisms in Imprinting Disorders

With the continuous improvement of diagnostic methods and the extensive molecular characterisation of ImpDis patient cohorts and mouse models, there is an increase of newly identified molecular alterations and (imprinted) genetic loci associated with ImpDis phenotypes. Not all new findings in the field of ImpDis can be described in this review, but we will focus on factors belonging to the 11p15.5 imprinting regions and their interaction partners.

In the last decade it has emerged as a general observation that many imprinted genes belong to common functional networks, either because of their physiological function or because they belong to the so-called *imprinted genes network* (IGN) (for review: (27)). Gene networks are derived from linked data associated with complex gene function and phenotypes. These networks combine massive transcriptome data sets and gene variants revealing genetic modifiers that modulate spatial and temporal expression of core developmental networks. This ultimately reflects coordinated mRNA synthesis via shared transcription factors (TFs), mRNA stability, mRNA translation, and protein stability.

As outlined earlier, there is considerable clinical and molecular overlap between different ImpDis, which might be explained by the proposed IGN presided by the zinc-finger TF *PLAGL1* which is co-expressed with hundreds of genes, many of which are imprinted (28). These include *H19*, *IGF2* and *CDKN1C* in both mouse and humans (figure 3)(28, 29). Modest changes in the abundance or activity of a single TF such as *PLAGL1* could result in the altered expression of downstream targets, including the ImpDis-associated genes *H19* and *CDKN1C* resulting in an effect of *PLAGL1* on the SRS and BWS phenotypes. Furthermore an additional imprinted zinc-finger TF *Peg3* also exhibits transactivation on multiple genes (30), including *GRB10* an imprinted gene associated cytogenetic aberrations in SRS (31).

Gene regulation is not a linear process, but rather occurs in the context of complex networks of interactions between multiple genes and mechanisms, which encompass TFs and post-transcriptional regulation. This is highlighted in the case of IGN, in which the TF *PLAGL1* influences the expression of the *H19* ncRNA, which itself acts as microRNAs (miRNA) sponge antagonizing numerous miRNAs (32) and encodes for miR-675 which would have an augmenting effect on target mRNAs (33). Consistent with this interactive IGN, numerous imprinted genes on different chromosomes, including *Gnas*, *Rtl1*, *Dlk2* and *IGF2r* are deregulated in mice carrying maternal deletions of *H19* (34). Interestingly *PLAGL1* expression levels remained constant in this model.

Recently, additional networks regulating growth associated imprinted genes have been described, including the role of unoccupied insulin and insulin-like growth factor 1 receptors (35)(figure 3). This novel non-canonical mechanism is also independent of *PLAGL1* despite influencing many of the same target genes, suggesting that the IGN can be subdivided into smaller interconnected 'hubs' (36).

Finally the paternally expressed ncRNA *IPW* located in the PWS region on chromosome 15 regulates the levels of maternally expressed transcripts within the imprinted cluster on chromosome 14 (37). The *trans*-acting repression of the *DLK1-DIO3* locus by *IPW* involves the recruitment of the H3K9 histone methyltransferase G9a to the chromosome 14 imprinting control regions, the IG-DMR. These observations support the rapidly expanding theory that the IGN influences clinical features associated with ImpDis, highlighted by individuals with TS14 who display PWS-like phenotypes (38). It remains to be determined if these co-expressed imprinted loci interact with in the nucleus, giving the IGN a physical dimension which may occur if they share common transcriptional factories.

Trans acting mechanisms are also the basis for the observation that genomic mutations in factors such as NLRPs and ZFP57 are associated with multi-locus imprinting disturbance (MLID). Loss of function mutations of *ZFP57* have been found in TNDM cases with MLID (39). In the mouse, *Zfp57* interacts with a specific target sequence in the methylated alleles of the ICRs, and its inactivation leads to loss of methylation at multiple imprinted loci (40, 41). Strikingly, while mouse *Zfp57* is associated with both imprinted and non-imprinted DMRs, it associates preferentially with *Zac1* and *Peg3*, mirroring the loci commonly affected in human patients with *ZFP57* mutations (42). NLRP mutations identified to date are maternal-effect, i.e. mutations in mothers are associated with MLID in their offspring. Maternal-effect *NLRP7* mutations are associated with hydatidiform moles, a pregnancy outcome with paternalisation of imprinting, which is incompatible with life (43, 44). Maternal mutations of *NLRP2* and *NLRP5* have been associated with MLID in liveborn offspring (13, 45), though, interestingly, the clinical features and epimutations in affected children are not consistent, suggesting that these mutations disrupt imprinting stochastically. Likewise, methylation patterns vary in hydatidiform moles caused by *NLRP7* mutation (20). However, hydatidiform moles show extreme hypomethylation of maternal imprinting marks only, whereas *NLRP5* mutations cause mosaic hypomethylation affecting both maternal and paternal marks, suggesting that *NLRP7* may exert its effect in the oocyte, while *NLRP5*'s action may be postzygotic. The inter-species variability and high similarity of genes in the NLRP cluster will pose challenges for disentangling their roles in ImpDis. However, the identification of *KHDC3L* and *TLE1* mutations impacting reproductive fitness (46, 47) suggests that maternal-effect genes may in future be implicated more widely in imprinting, epigenetics and development.

### **Advances in Imprinting Disorders III: Improvement of molecular diagnostics**

Until recently, molecular testing for ImpDis was restricted to single disease-specific loci. The detection rates at least in PWS, AS, SRS, and BWS are more or less well established (table 1), but technical, biological and clinical factors influence the diagnostic yield of the available assays.

A broad range of molecular tests are available (for review: (48)), but their different sensitivities and the lack of standardization make a comparison of the molecular results between different studies difficult. Furthermore mosaicism hampers molecular ImpDis testing. It frequently occurs in patients carrying UPiD and epimutations, and can be explained by the mostly post-zygotic origin of these changes. The level of mosaicism can show a broad range, and sometimes differs remarkably between different tissues (49). The limited sensitivity of current single-locus tests might therefore restrict their diagnostic yield. However, the identification and discrimination of the molecular ImpDis subtype is required for a precise molecular diagnosis and a well-directed genetic counselling.

The broadening of molecular testing in the last years has shown that there is a considerable overlap between the different ImpDis, and the application of single-locus test can preclude the diagnosis of basic molecular defects and might leave a patient without diagnosis (50). The application of tests aiming on different imprinted loci in ImpDis diagnostics allows the identification of unexpected molecular findings and circumvents the decision to apply a locus specific test in this group of overlapping and heterogeneous clinical pictures. Furthermore, a considerable number of ImpDis patients exhibit aberrant methylations at different imprinted loci (MLID) (49). These patients might show a broad clinical spectrum and the phenotype can be ambiguous or even atypical for one of the known ImpDis.



One major prerequisite for the future comprehensive diagnostic analysis of ImpDis loci is the identification and definition of a standardized set of imprinted loci, DMRs and CpG islands (for review: (48)). The first step has been undertaken by the European network of imprinting disorders EUCID.net with the introduction of common ImpDis names and abbreviations, and the LRG/HGV-based naming of DMRs and definition of their physical positions (see [www.imprinting-disorders.eu](http://www.imprinting-disorders.eu)). To make the huge number of mutations and epimutations from different diagnostic and research institutions available to the public, the common use of LOVD (Leiden open variation database) as the common variation database is suggested (<http://www.lovd.nl/3.0/home>) and has been initiated by EUCID.net.

An increasing number of studies show that the aforementioned problems in diagnosis and investigation of ImpDis can be diminished by the use of new tests targeting multiple loci and/or a total exome and genome analysis. Deep-sequencing NGS assays are in development for these purposes, and it has been shown that NGS is able to detect even low-level mosaicism (3, 5).

#### **Advances in ImpDis IV: clinical diagnosis, genetic counselling and treatment**

With the increasing knowledge on the molecular basis and clinical spectrum of ImpDis and the improved molecular testing strategies, the foundation stone is laid for a more directed genetic counselling of the families and personalized therapeutic approaches.

However, like for the molecular nomenclature, the use of a controlled and standardized vocabulary for describing clinical entities is required in the clinical diagnosis of ImpDis, as it is now provided by HPO (human phenotype ontology, <http://www.human-phenotype-ontology.org/>). This HPO nomenclature is the basis for a common phenotyping questionnaire, which is now also provided as a common phenotyping tool by the EUCID.net.

Despite or even because of the increasing reports on heterogeneous molecular findings in the majority of ImpDis, it is emphasized that the diagnosis of nearly all ImpDis is a primarily clinical diagnosis, but that molecular testing allows confirmation and the identification of the molecular subtype which is a prerequisite for a specific clinical management (e.g. tumour surveillance in BWS). Furthermore, a normal test result does not exclude the diagnosis of an ImpDis but differential diagnoses with divergent clinical consequences and recurrence risks have to be considered (for differential diagnosis of the different IDs we suggest to seek advice from the ImpDis -specific literature listed in table 2). However, due to their clinical heterogeneity the diagnosis of ImpDis is often difficult as many features are non-specific. This results in a large and often undirected and arbitrary number of molecular tests in patients with only few ImpDis features, and vice versa in a low diagnostic yield (e.g. (51)). Thus, at least for the more frequent IDs clinical scoring systems have been proposed (table 2), but the increasing numbers of suggested scores in some IDs and their low acceptance and limited application illustrate the uncertainty of clinicians to use them. The general acceptance of the Netchine-Harbison-Score for SRS (52) by the SRS consensus group in 2015 and the development of tests for BWS and PHP by similar consensus activities organized by the EUCID.net hopefully will solve this problem and will contribute to a common clinical diagnosis of ImpDis. These approaches towards a common language in ImpDis and their diagnosis are complemented by the drafting of clinical utility gene cards (CUGC), GeneReviews, and recently by the first interdisciplinary diagnostic and clinical consensus guidelines (table 2).

All these activities aim to facilitate the daily work in clinical diagnosis and genetic counselling of patients and families suspicious for ImpDis. In case the clinical diagnosis can

be confirmed by molecular testing, a careful characterization of the molecular disturbance is required to determine the molecular subtype and its potential to be inherited.

In case of a positive testing result, different recurrence risks can be delineated (table 1), which are not only influenced by the type of alteration but also by the sex of the parent who contributes the affected allele. For UPD, the recurrence risk is generally low but differs among the ImpDis: whereas it can be neglected in BWS as  $\text{upd}(11\text{p})\text{pat}$  originates from postzygotic mitotic errors, in case of chromosomes 14 and 15 it can increase because it might be caused by a (familial) translocation. CNVs generally harbor the potential to be caused by parental translocations with a significant increase of recurrent risks, also for other different (imprinting) disorders. The difficulty of recurrence risk determination and phenotype prediction in case of CNVs is not only hampered by the parental origin of the affected segment, but also by the size of the aberrant segment and its content of genes and regulative elements, as illustrated for 11p15.5 (e.g. (53)). Epimutations mainly occur sporadically and familial cases have rarely been reported. Thus, the recurrence risk is only slightly increased, with the exception of secondary epimutations caused by genomic alterations. It is also unclear in case of MLID, here families with maternal effect mutations in NLPR genes have been reported, and NLRP mutation carrier women are at an increased risk for children with aberrant DMR methylation.

### **Conclusions and Outlook**

The last years have seen a significant progress in deciphering molecular causes and pathomechanisms of ImpDis, to better understand the complex interactions between imprinted loci and thereby regulated factors. The application of new high-throughput technologies and deep phenotyping approaches will contribute to a comprehensive and improved diagnostic yield as a significant step towards personalized therapeutic managements.

### **Acknowledgement**

All authors are members of the EUCID.net network, funded by COST (BM1208). TE, LS and MB are funded by the German Ministry of research and education (01GM1513B).

## Figures and Tables

Table 1

Disorder	Chromosome	Molecular Alterations	Frequencies	MLID	recurrence risk	Clinical features
Transient Neonatal Diabetes mellitus (TNDM)	6q24	UPD(6)pat	41%		<1%	IUGR, transient diabetes, hyperglycemia without ketoacidosis, macroglossia, omphalocele
		dup(6q)	29%		increased in case of a paternal structural variation	
		<i>PLAGL1</i> :alt-TSS-DMR: LOM	30%	50%	in case of a <i>ZFP57</i> mutation	
Silver-Russell syndrome (SRS)	7	upd(7)mat	7-10%	1 case	<1%, but a single familial structural variation has been reported	IUGR/PNGR, relative macrocephaly, asymmetry, G1prominent forehead/triangular face, feeding difficulties
		CNVs (dup7p), del7q	single cases		increased in case of a familial structural variation	
	11p15.5	upd(11)mat	n=1	-	<1%	
		dup(11p15)mat	1-2%	-	increased in case of a familial structural variation	
		<i>H19/IGF2</i> :IG-DMR: LOM	>38%	~10%	only single families, risk might be increased in case of MLID	
		<i>CDKN1C</i> mutations	n=1	-	50% in case of maternal transmission	
<i>IGF2</i> mutations	n=1	-	50% in case of paternal transmission			
Birk-Barel mental retardation	8q24.3	<i>KCNK9</i> mutations	unknown	-	50% in case of maternal transmission	intellectual disability, hyperactivity, feeding difficulties, hypotonia,

						elongated face
Beckwith-Wiedemann syndrome (BWS)		upd(11)pat	20%	-	no	pre- and postnatal overgrowth, organomegaly, macroglossia, omphalocele, neonatal hypoglycemia, hemihypertrophy, increased tumour risk
		uniparental diploidy*	~ 10%?			
		paternal UPD	~ 90%			
		dup(11p15)pat	1-2%	-	increased in case of a familial structural variation	
		<i>H19/IGF2</i> :IG-DMR: GOM	4%	-	20%+F28 (in case of microdeletions or SNPs in the OCT4/SOX2 binding site)	
		<i>KCNQ1OT1</i> :TSS-DMR: LOM	50%	25%	only single families have been reported, but the risk might be increased when MLID	
		<i>CDKN1C</i> mutations	5%	-	50% in case of maternal transmission	
Temple syndrome (UPD(14)mat)	14q32	upd(14)mat	78.4%	-	<1%, but increased in case of familial Robertsonian translocation	IUGR,PNGR, hypotonia, feeding difficulties in infancy, truncal obesity, scoliosis, precocious puberty
		del(14q32)pat	9.8%	-	<1%, but increased in case of familial translocation	
		<i>MEG3/DLK1</i> :IG-DMR and <i>MEG3</i> :TSS-DMR: LOM	11.7%	NR	unknown	

Kagami-Ogata syndrome (UPD(14)pat)		upd(14)pat	65.4%	-	<1%, but increased in case of familial Robertsonian translocation	IUGR, polyhydramnion, abdominal and thoracic wall defects, bell-shaped thorax, coat-hanger ribs
		del(14q32)mat	19.2%	-	<1%, but increased in case of familial translocation	
		<i>MEG3/DLK1</i> :IG-DMR and <i>MEG3</i> :TSS-DMR: GOM	15.4%	NR		
Angelman syndrome (AS)	15q11q13	UPD(15)pat	1-2%	-	<1%	mental retardation, microcephaly, no speech, unmotivated laughing, ataxia, seizures
		del(15q11q13)mat	75%	-	<1%, but increased in case of familial translocation	
		<i>SNURF</i> :TSS-DMR: LOM	~3%	-	Up to 50%	
		<i>UBE3A</i> mutations	5-10%	-	Up to 50%	
Prader-Willi syndrome (PWS)		upd(15)mat	25-30%	-	<1%	PWS, mental retardation, neonatal hypotonia, hypogonadism, hypopigmentation, obesity/hyperphagia
		del(15q 11q13)pat	70-75%	-	<1%, but increased in case of familial translocation	
		<i>SNURF</i> :TSS-DMR: GOM	~1%+D43	1 case	Up to 50%	
Precocious puberty	15q11.2	<i>MKRN3</i> mutations	unknown	-	50% in case of paternal transmission	Precocious puberty (girls: 5.75 years, boys: 8.10 years)

Schaaf-Yang syndrome (SHFYNG)	15q11.2	<i>MAGEL2</i> mutations	unknown	-	50% in case of paternal transmission	neonatal hypotonia, feeding problems in infancy, then hyperphagia, developmental delay, hypogonadism
Sporadic Pseudohypoparathyroidism Ib	20q13	upd(20)pat	10-25%	-	<1%	resistance to PTH and other hormones, Albright hereditary osteodystrophy, subcutaneous ossifications, feeding behaviour anomalies, abnormal growth
		del(20q13)	rare		<1%, but increased in case of familial translocation	
		<i>GNAS-NESP</i> :TSS-DMR: LOM <i>GNAS-XL</i> :Ex1-DMR: LOM <i>GNAS A/B</i> :TSS-DMR	>60%	12.5%	<1%	
upd(20)mat	20	upd(20)mat	unknown	9 cases	<1%?, but familial translocation should be considered	IUGR, PNGR, failure to thrive

**Table 1** Overview on the molecular and clinical findings in the currently known ImpDis. (IUGR intrauterine growth retardation; PNGR postnatal growth retardation; LOM loss of methylation; GOM gain of methylation; PTH parathormone; \*paternal uniparental disomy: all chromosomes are affected (formerly named genomewide UPD))

# Accepted Article

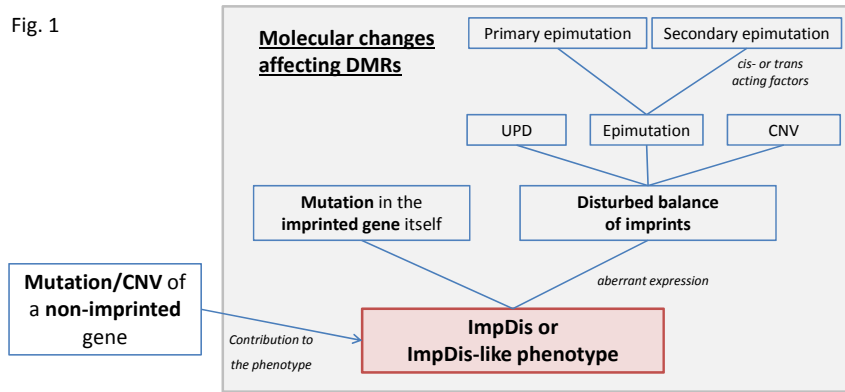
Table 2

ImpDis	OMIM	Clinical Scoring systems/ clinical diagnosis	CUGC	GeneReviews®	Molecular Guidelines	Clinical guidelines/ Consensus guidelines
TNDM	601410	NA	(60)	yes	NA	NA
SRS	180860	(52)	(70)	yes	(50)	in preparation
BB-MR	612292	NA	NA	NA	NA	NA
BWS	130650	(54, 55)	(62)	yes	(50)	in preparation
TS14	616222	(58)	NA	NA	NA	NA
KOS14	608149	(59)	NA	NA	NA	NA
PWS	176270	(56)	(63)	yes	(66)	(68)
AS	105830	NA	(64)	yes	(66)	NA
PPS-2	615346	NA	NA	NA	NA	NA
SHFYNG	615547	NA	NA	NA	NA	NA
PHPIb	603233	(57)	(65)	(57)	(67)	in preparation
upd(20)mat	NA	(26)	NA	NA	NA	NA

**Table 2** Diagnostic, clinical and management guidelines published for ImpDis. (\*<http://www.ncbi.nlm.nih.gov/books/NBK1116/>; CUGC clinical utility gene cards; NA not available)

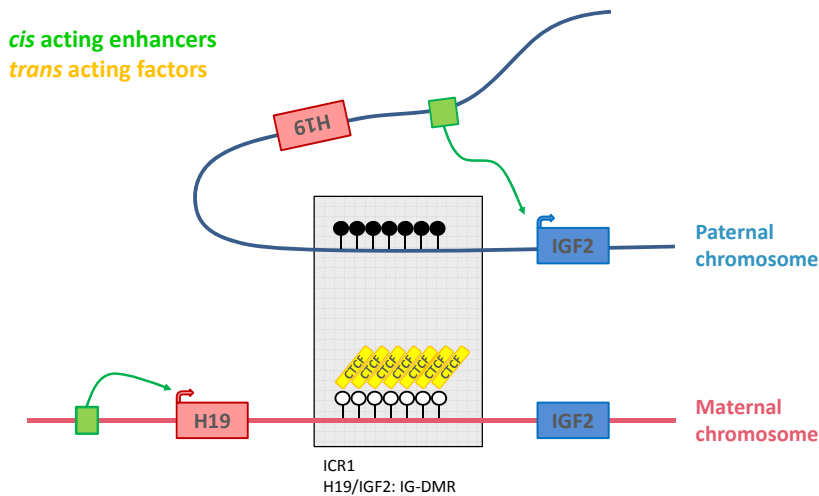


Fig. 1

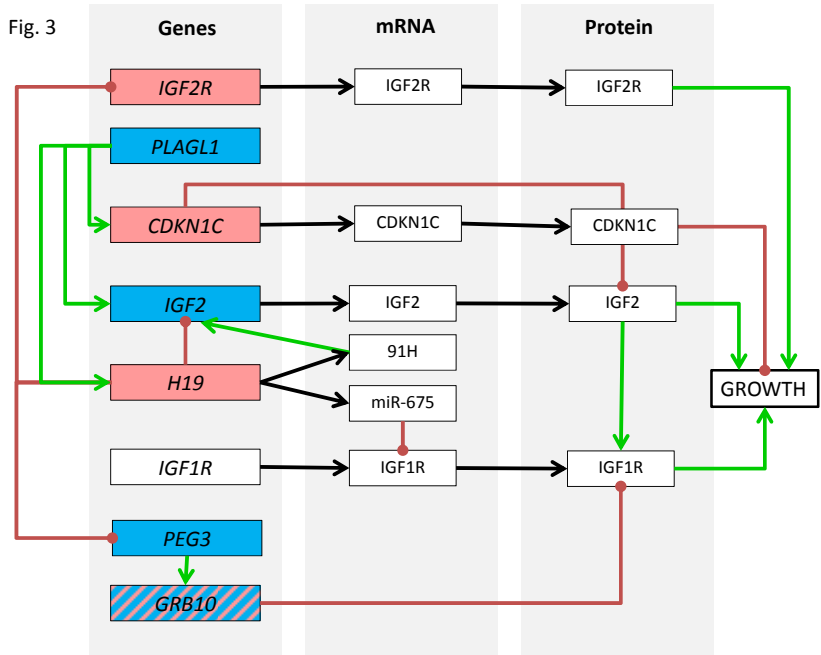


**Figure 1** Schematic overview on the currently known molecular alterations and their functional consequences leading to ImpDis and ImpDis-like phenotypes.

Fig. 2



**Figure 2** Illustration of the influence of cis-acting elements and trans-acting factors on imprinted genes and their expression for the imprinted region in 11p15.



**Figure 3** Exemplary illustration of the physiological interaction between imprinted and not imprinted genes affecting growth. The different interactions are summarized from numerous studies in mice and human tissues, thus the capitalization of the gene names is not linked with a specific organism. (*blue* paternally expressed genes, *red* maternally expressed genes, *white* not imprinted, *blue and red stripes* gene with tissue and species specific and opposite imprinting; *red lines* inhibitory effect, *green arrow* promoting effect).

## References

- 1 Eggermann T, Perez de Nanclares G, Maher ER, et al. Imprinting disorders: a group of congenital disorders with overlapping patterns of molecular changes affecting imprinted loci. *Clin Epigenet* 2015; 7:123.
- 2 Knoll JH, Nicholls RD, Magenis RE, Graham JM Jr, Lalande M, Latt SA. Angelman and Prader-Willi syndromes share a common chromosome 15 deletion but differ in parental origin of the deletion. *Am J Med Genet* 1989; 32: 285-90.
- 3 Beygo J, Elbracht M, de Groot K, et al. Novel deletions affecting the MEG3-DMR provide further evidence for a hierarchical regulation of imprinting in 14q32. *Eur J Hum Genet* 2015; 23: 180-8.
- 4 Kagami M, O'Sullivan MJ, Green AJ, et al. The IG-DMR and the MEG3-DMR at human chromosome 14q32.2: hierarchical interaction and distinct functional properties as imprinting control centers. *PLoS Genet* 2010; 6: e1000992.
- 5 Beygo J, Citro V, Sparago A, et al. The molecular function and clinical phenotype of partial deletions of the IGF2/H19 imprinting control region depends on the spatial arrangement of the remaining CTCF-binding sites. *Hum Mol Genet* 2013; 22: 544-57.
- 6 Engel E. A new genetic concept: uniparental disomy and its potential effect, isodisomy. *Am J Med Genet* 1980; 6: 137-43.
- 7 Spence JE, Perciaccante RG, Greig GM, et al. Uniparental disomy as a mechanism for human genetic disease. *Am J Hum Genet* 1988; 42: 217-26.
- 8 Kotzot D, Schmitt S, Bernasconi F, et al. Uniparental disomy 7 in Silver-Russell syndrome and primordial growth retardation. *Hum Mol Genet* 1995; 4: 583-7.
- 9 Horsthemke B. Mechanisms of imprint dysregulation. *Am J Med Genet C* 2010; 15: 154C:321-8.
- 10 Dias RP, Maher ER. Genes, assisted reproductive technology and trans-illumination. *Epigenomics* 2013; 5: 331-40.
- 11 Flori E, Biancalana V, Girard-Lemaire F, et al. Difficulties of genetic counseling and prenatal diagnosis in a consanguineous couple segregating for the same translocation (14;15) (q11;q13) and at risk for Prader-Willi and Angelman syndromes. *Eur J Hum Genet* 2004; 12: 181-6.
- 12 Blik J, Alders M, Maas SM, et al. Lessons from BWS twins: complex maternal and paternal hypomethylation and a common source of haematopoietic stem cells. *Eur J Hum Genet* 2009; 17: 1625-1634.
- 13 Docherty LE, Rezwani FI, Poole RL, et al. Mutations in NLRP5 are associated with reproductive wastage and multilocus imprinting disorders in humans. *Nat Commun* 2015; 1;6:8086. doi: 10.1038/ncomms9086.

- 14 Poole RL, Docherty LE, Al Sayegh A, et al. Targeted methylation testing of a patient cohort broadens the epigenetic and clinical description of imprinting disorders. *Am J Med Genet A* 2013: 161:2174-82.
- 15 Orstavik RE, Tommerup N, Eiklid K, Orstavik KH. Non-random X chromosome inactivation in an affected twin in a monozygotic twin pair discordant for Wiedemann-Beckwith syndrome. *Am J Med Genet* 1995: 56: 210-214.
- 16 Bens S, Kolarova J, Gillessen-Kaesbach G, et al. The differentially methylated region of MEG8 is hypermethylated in patients with Temple syndrome. *Epigenomics* 2015: 7: 1089-97.
- 17 Barel O, Shalev SA, Ofir R, et al. Maternally inherited Birk Barel mental retardation dysmorphism syndrome caused by a mutation in the genomically imprinted potassium channel KCNK9. *Am J Hum Genet* 2008: 83: 193-9.
- 18 Ruf N, Bähring S, Galetzka D, et al. Sequence-based bioinformatic prediction and QUASEP identify genomic imprinting of the KCNK9 potassium channel gene in mouse and human. *Hum Mol Genet* 2007: 16: 2591-9.
- 19 Ylisaukko-oja T, Alarcón M, Cantor RM, et al. Search for autism loci by combined analysis of Autism Genetic Resource Exchange and Finnish families. *Ann Neurol* 2006: 59: 145-55.
- 20 Sanchez-Delgado M, Martin-Trujillo A, Tayama C, et al. Absence of Maternal Methylation in Biparental Hydatidiform Moles from Women with NLRP7 Maternal-Effect Mutations Reveals Widespread Placenta-Specific Imprinting. *PLoS Genet* 2015: 11: e1005644. doi: 10.1371.
- 21 Macedo DB, Abreu AP, Reis AC, Montenegro LR, Dauber A, Beneduzzi D. Central precocious puberty that appears to be sporadic caused by paternally inherited mutations in the imprinted gene makorin ring finger 3. *J Clin Endocrinol Metab* 2014: 99: E1097-103.
- 22 de Vries L, Gat-Yablonski G, Dror N, Singer A, Phillip M. A novel MKRN3 missense mutation causing familial precocious puberty. *Hum Reprod* 2014: 29: 2838-43.
- 23 Abreu AP, Dauber A, Macedo DB, et al. Central precocious puberty caused by mutations in the imprinted gene MKRN3. *N Engl J Med* 2013: 368: 2467-75.
- 24 Schreiner F, Gohlke B, Hamm M, Korsch E, Woelfle J. MKRN3 mutations in familial central precocious puberty. *Horm Res Paediatr* 2014: 82: 122-6.
- 25 Schaaf CP, Gonzalez-Garay ML, Xia F, et al. Truncating mutations of MAGEL2 cause Prader-Willi phenotypes and autism. *Nature Genet* 2013: 45: 1405-1408.
- 26 Mulchandani S, Bhoj E, Luo M, et al. Maternal Uniparental Disomy of Chromosome 20: A Novel Imprinting Disorder of Growth Failure. *Genet Med* 2015 Aug 6. doi: 10.1038/gim.2015.103.

- 27 Patten MM, Cowley M, Oakey RJ, Feil R. Regulatory links between imprinted genes: evolutionary predictions and consequences. *Proc Biol Sci* 2016: 283: pii: 20152760. doi: 10.1098/rspb.2015.2760.
- 28 Varrault A, Gueydan C, Delalbre A, et al. ZAC1 regulates an imprinted gene network critically involved in the control of embryonic growth. *Dev Cell* 2006: 11: 711-22.
- 29 Iglesias-Platas I, Martin-Trujillo A, Petazzi P, Guillaumet-Adkins A, Esteller M, Monk D. Altered expression of the imprinted transcription factor PLAGL1 deregulates a network of genes in the human IUGR placenta. *Hum Mol Genet* 2014: 23: 6275-85.
- 30 Thiaville MM, Huang JM, Kim H, Ekram MB, Roh TY, Kim J. DNA-binding motif and target genes of the imprinted transcription factor PEG3. *Gene* 2013: 512: 314-20.
- 31 Monk D, Wakeling EL, Proud V, et al Duplication of 7p11.2-p13, including GRB10, in Silver-Russell syndrome. *Am J Hum Genet* 2000: 66: 36-46-
- 32 Kallen AN, Zhou XB, Xu J, et al. The imprinted H19 lncRNA antagonizes let-7 microRNAs. *Mol Cell* 2013: 52: 101-12.
- 33 Cai X, Cullen BR. The imprinted H19 noncoding RNA is a primary microRNA precursor. *RNA* 2007: 13: 313-6.
- 34 Gabory A, Ripoché MA, Le Digarcher A, et al. H19 acts as a trans regulator of the imprinted gene network controlling growth in mice. *Development* 2009: 136: 3413-21.
- 35 Boucher J, Charalambous M, Zarse K, et al. Insulin and insulin-like growth factor 1 receptors are required for normal expression of imprinted genes. *Proc Natl Acad Sci USA* 2014: 111: 14512-7.
- 36 Macneil LT, Walhout AJ. Gene regulatory networks and the role of robustness and stochasticity in the control of gene expression. *Genome Res* 2011, 21, 645-57.
- 37 Stelzer Y, Sagi I, Yanuka O, Eiges R, Benvenisty N. The noncoding RNA IPW regulates the imprinted DLK1-DIO3 locus in an induced pluripotent stem cell model of Prader-Willi syndrome. *Nat Genet* 2014, 46: 551-7.
- 38 Hosoki K, Kagami M, Tanaka T, et al. Maternal uniparental disomy 14 syndrome demonstrates prader-willi syndrome-like phenotype. *J Pediatr* 2009, 155, 900-903.
- 39 Mackay DJ, Callaway JL, Marks SM, et al. Hypomethylation of multiple imprinted loci in individuals with transient neonatal diabetes is associated with mutations in ZFP57. *Nat Genet* 2008, 40, 949-51.
- 40 Li X, Ito M, Zhou F, Youngson N, Zuo X, Leder P, Ferguson-Smith AC. A maternal-zygotic effect gene, *Zfp57*, maintains both maternal and paternal imprints. *Dev Cell* 2008: 15: 547-57.
- 41 Quenneville S, Verde G, Corsinotti A, et al. In embryonic stem cells, ZFP57/KAP1 recognize a methylated hexanucleotide to affect chromatin and DNA methylation of imprinting control regions. *Mol Cell* 2011: 44: 361-72.

- 42 Strogantsev R, Krueger F, Yamazawa K, et al. Allele-specific binding of ZFP57 in the epigenetic regulation of imprinted and non-imprinted monoallelic expression. *Genome Biol* 2015; 16: 112.
- 43 Murdoch S, Djuric U, Mazhar B et al. Mutations in NALP7 cause recurrent hydatidiform moles and reproductive wastage in humans. *Nat Genet* 2006; 38: 300-2.
- 44 Nguyen NM, Slim R. Genetics and epigenetics of recurrent hydatidiform moles: Basic science and genetic counselling. *Curr Obstet Gynecol Rep* 2014; 3: 55-64.
- 45 Meyer E, Lim D, Pasha S, et al. Germline mutation in NLRP2 (NALP2) in a familial imprinting disorder (Beckwith-Wiedemann Syndrome). *PLoS Genet* 2009; 5: e1000423.
- 46 Parry DA, Logan CV, Hayward BE et al. Mutations causing familial biparental hydatidiform mole implicate c6orf221 as a possible regulator of genomic imprinting in the human oocyte. *Am J Hum Genet* 2011; 89: 451-8.
- 47 Alazami AM, Awad SM, Coskun S, et al. TLE6 mutation causes the earliest known human embryonic lethality. *Genome Biol* 2015; 16: 240.
- 48 Soellner L, Monk D, Rezwan FI, Begemann M, Mackay D, Eggermann T. Congenital imprinting disorders: Application of multilocus and high throughput methods to decipher new pathomechanisms and improve their management. *Mol Cell Probes* 2015; 29:282-90.
- 49 Azzi S, Salem J, Thibaud N, et al. A prospective study validating a clinical scoring system and demonstrating phenotypical-genotypical correlations in Silver-Russell syndrome. *J Med Genet* 2015; 52: 446-53.
- 50 Eggermann K, Bliok J, Brioude F, et al. EMQN best practice guidelines for the molecular genetic testing and reporting of chromosome 11p15 Imprinting Disorders – Silver-Russell and Beckwith-Wiedemann syndrome. *Eur J Hum Genet*: in press
- 51 Eggermann T, Heilsberg AK, Bens S, et al. Additional molecular findings in 11p15-associated imprinting disorders: an urgent need for multi-locus testing. *J Mol Med* 2014; 92: 769-77.
- 52 Azzi S, Steunou V, Tost J, et al. Exhaustive methylation analysis revealed uneven profiles of methylation at IGF2/ICR1/H19 11p15 loci in Russell Silver syndrome. *J Med Genet* 2015; 52: 53-60.
- 53 Begemann M, Spengler S, Gogiel M, et al. Clinical significance of copy number variations in the 11p15.5 imprinting control regions: new cases and review of the literature. *J Med Genet* 2012; 49:547-53.
- 54 Elliott M, Bayly R, Cole T, Temple IK, Maher ER. Clinical features and natural history of Beckwith-Wiedemann syndrome: presentation of 74 new cases. *Clin Genet* 1994; 46: 168-174.
- 55 DeBaun MR, Tucker MA. Risk of cancer during the first four years of life in children from The Beckwith-Wiedemann Syndrome Registry. *J Pediatr* 1998; 132: 398-400.

- 56 Gunay-Aygun M, Schwartz S, Heeger S, O'Riordan MA, Cassidy SB. The changing purpose of Prader-Willi syndrome clinical diagnostic criteria and proposed revised criteria. *Pediatrics* 2001; 108: E92.
- 57 Mantovani G. Clinical review: Pseudohypoparathyroidism: diagnosis and treatment. *J Clin Endocrinol Metab* 2011; 96: 3020-30.
- 58 Ioannides Y, Lokulo-Sodipe K, Mackay DJ, Davies JH, Temple IK. Temple syndrome: improving the recognition of an underdiagnosed chromosome 14 imprinting disorder: an analysis of 51 published cases. *J Med Genet* 2014; 51: 495-501.
- 59 Ogata T, Kagami M. Kagami-Ogata syndrome: a clinically recognizable upd(14)pat and related disorder affecting the chromosome 14q32.2 imprinted region. *J Hum Genet* 2015: in press
- 60 Mackay D, Bens S, Perez de Nanclares G, Siebert R, Temple IK. Clinical utility gene card for: Transient Neonatal Diabetes Mellitus, 6q24-related. *Eur J Hum Genet* 201; 22: doi: 10.1038/ejhg.2014.27.
- 61 Eggermann T1, Buiting K, Temple IK. Clinical utility gene card for: Silver-Russell syndrome. *Eur J Hum Genet* 2011; 19: . doi: 10.1038/ejhg.2010.202. Epub 2010 Dec 8.
- 62 Eggermann T, Algar E, Lapunzina P, et al. Clinical utility gene card for: Beckwith-Wiedemann Syndrome. *Eur J Hum Genet* 2014; 22. doi: 10.1038/ejhg.2013.132. Epub 2013 Jul 3.
- 63 Buiting K, Cassidy SB, Driscoll DJ, et al. Clinical utility gene card for: Prader-Willi Syndrome. *Eur J Hum Genet* 2014; 22. doi: 10.1038/ejhg.2014.66. Epub 2014 Apr 16.
- 64 Buiting K, Clayton-Smith J, Driscoll DJ, et al. Clinical utility gene card for: Angelman Syndrome. *Eur J Hum Genet* 2015, Feb;23(2). doi: 10.1038/ejhg.2014.93. Epub 2014 Jun 4.
- 65 Mantovani G1, Linglart A, Garin I, Silve C, Elli FM, de Nanclares GP. Clinical utility gene card for: pseudohypoparathyroidism. *Eur J Hum Genet* 2013; 21: doi: 10.1038/ejhg.2012.211. Epub 2012 Sep 12.
- 66 Ramsden SC1, Clayton-Smith J, Birch R, Buiting K. Practice guidelines for the molecular analysis of Prader-Willi and Angelman syndromes. *BMC Med Genet* 2010; 11:70.
- 67 Garin I, Mantovani G, Aguirre U, et al. European guidance for the molecular diagnosis of pseudohypoparathyroidism not caused by point genetic variants at *GNAS*: an EQA study. *Eur J Hum Genet* 2015; 23: 438-44.
- 68 Deal CL, Tony M, Höybye C, Allen DB, Tauber M, Christiansen JS. GrowthHormone Research Society workshop summary: consensus guidelines for recombinant human growth hormone therapy in Prader-Willi syndrome. *J Clin Endocrinol Metab* 2013; 98: E1072-87.