

Kent Academic Repository

Full text document (pdf)

Citation for published version

Naim, M.M. and Spiegler, V.L.M. and Wikner, J. and Towill, D.R. (2017) Identifying the causes of the bullwhip effect by exploiting control block diagram manipulation with analogical reasoning. *European Journal of Operational Research*, 263 (1). pp. 240-246. ISSN 0377-2217.

DOI

<https://doi.org/10.1016/j.ejor.2017.05.014>

Link to record in KAR

<http://kar.kent.ac.uk/61932/>

Document Version

Author's Accepted Manuscript

Copyright & reuse

Content in the Kent Academic Repository is made available for research purposes. Unless otherwise stated all content is protected by copyright and in the absence of an open licence (eg Creative Commons), permissions for further reuse of content should be sought from the publisher, author or other copyright holder.

Versions of research

The version in the Kent Academic Repository may differ from the final published version.

Users are advised to check <http://kar.kent.ac.uk> for the status of the paper. **Users should always cite the published version of record.**

Enquiries

For any further enquiries regarding the licence status of this document, please contact:

researchsupport@kent.ac.uk

If you believe this document infringes copyright then please contact the KAR admin team with the take-down information provided at <http://kar.kent.ac.uk/contact.html>

Identifying the causes of the bullwhip effect by exploiting control block diagram manipulation with analogical reasoning

Mohamed M. Naim¹, Virginia L. Spiegler², Joakim Wikner³, Denis R. Towill^{1#}

¹ Cardiff Business School, Cardiff University, United Kingdom (UK)

Corresponding author: NaimMM@cf.ac.uk

² Kent Business School, University of Kent, United Kingdom (UK)

³ Department of Management and Engineering, Linköping University, Sweden

Posthumously: Prof. Denis R. Towill, 1933-2015 – a colleague and friend who was instrumental in motivating the research described in this paper

Identifying the causes of the bullwhip effect by exploiting control block diagram manipulation with analogical reasoning

Abstract

Senior managers when solving problems commonly use analogical reasoning, allowing a current ‘target problem’ situation to be compared to a valid previous experienced ‘source problem’ from which a potential set of ‘candidate solutions’ may be identified. We use a single-echelon of the often-quoted Forrester (1961) production-distribution system as a case ‘target model’ of a complex production and inventory control system that exhibits bullwhip. Initial analogical reasoning based on ‘surface similarity’ would presuppose a classic control engineering ‘source model’ consisting of a phase-lag feedback system for which it is difficult to derive the transfer function. Simulation alone would have to be relied on to mitigate the bullwhip effect. By using z-transform block diagram manipulation, the model for a single-echelon, consisting of 17 difference equations with five feedback loops is shown to have exact analogy to Burns and Sivazlian’s (1978) second order system that has no feedback. Therefore, this more appropriate ‘source model’ is based on a deeper understanding of the ‘behavioural similarities’ which indicates that the bullwhip effect is not in the case of the ‘target model’ due to feedback control but due to a first-order derivative, ‘phase advance’, term in the feed forward numerator path. Hence a more appropriate ‘candidate solution’ can be found via the use of a ‘recovery’ filter. An interdisciplinary framework for exploiting control engineering block diagram manipulation, utilising analogical reasoning, in a practical setting is presented, as is an example in a contemporary supply chain setting.

Keywords: (P) Systems dynamics, Forrester effect, system simplification, z-transform, simulation.

1. Introduction

Forrester’s (1958, 1961) seminal work on Industrial Dynamics is still cited to this day as an explanation for, or used synonymously with, the ‘bullwhip effect’ (e.g. in EJOR, Zhang & Burke, 2011, Ma et al., 2015, Wang and Disney, 2015). The ‘bullwhip effect’ is the phenomenon by which variance in the order flow increases upstream from one business to the next in the supply chain (Croson and Donohue, 2006). Lee et al. (1997a, b) first coined the term and suggested a number of categories for the causes of bullwhip including demand signal processing, order batching, inventory rationing, and price fluctuations. The former is also termed the Forrester Effect (Towill, 1997) and is attributed to the structure of an ordering system, the combination of decision rules, material and information delays, feedback loops and nonlinearities present in the system. The original Forrester paper (1958) and the subsequent text book (1961) formed the foundation for Industrial Dynamics, or what is now termed System Dynamics, the school of thought that relates system structures to dynamic behaviour in organisations. A fundamental principle of System Dynamics is that “feedback theory explains how decisions, delays, and predictions can produce either good control or dramatically unstable operation” (Forrester, 1958).

Gary et al. (2008) note that the use of system archetypes to understand problems and find solutions relates to the use of analogical reasoning (AR) (Gavetti and Rivkin, 2005). AR has been studied in the System Dynamics arena by Gonzalez

and Wong (2011). They undertook experiments into how decision makers draw analogies between different but apparently similar stock and flow problems and how they differentiate between surface and behavioural similarity:

“surface similarity is based on the mere appearance between two objects, whereas behavioural similarity is based on the function, matching relations, and final goal of the problems even when they do not appear to be similar.” (Gonzalez and Wong, 2011)

As Gavetti and Rivkin (2005) point out more generally - “Dangers arise when strategists draw an analogy on the basis of superficial similarity, not deep causal traits”, that is, there is reliance on what is termed ‘surface similarity’. But as Forrester himself noted in an interview - “The trouble with systems thinking, is it allows you to misjudge a system. You have this high-order, nonlinear, dynamic system in front of you as a diagram on the page. You presume you can understand its behaviour by looking at it, and there’s simply nobody who can do that” (Fisher, 2005). This reinforces Richardson’s (1991) argument that simple visual inspection of causal loop diagrams to determine system stability is insufficient and deeper understanding of the underlying control mechanisms is required.

Our research therefore covers the interdisciplinary space that brings together three disciplines, namely, General Management, as per Gavetti and Rivkin (2005), System Dynamics, (e.g. Gary et al., 2008) and Control Engineering, as typified by Wikner et al. (1992). While, from an Operational Research perspective, System Dynamics was originally considered to lack methodological rigour, as discussed by Sharp and Price (1984), it is now a commonly utilised method (e.g. Saleh et al., 2010). The latter has strong foundational contributions to Operational Research studies of inventory control systems (e.g. Vassion, 1955) and is still of value to the present (e.g. Dejonckheere et al., 2004, Spiegler et al., 2016). Our approach to methodological unification is commensurate with modern day management challenges that brings together “a wide variety of disciplines such as OM [operations management], OR [operational research] and systems dynamics” and may be branded as many different names including “supply chain, OM, management science, industrial and production engineering and OR” (MacCarthy et al., 2013).

In deriving our interdisciplinary method, we use the Forrester (1961) model as a case example of what at first sight seems a highly complicated production and inventory control system. As the Forrester model is often quoted synonymously with the ‘bullwhip effect’ then it seems reasonable to use it as a classic reference, as done by Wikner et al. (1992) and more recently Spiegler et al. (2016), by which to test new innovations in mitigating the ‘bullwhip effect’. Also, given the fact that Forrester himself criticised the superficial visual inspections of feedback systems, it seems highly appropriate to use his seminal model as a reference.

The original Forrester (1961) model, was documented as series of simulation equations which we retain for easy cross-referencing and as given in Appendix 1. We do not show all the equations for all echelons here but rather, in exemplifying the control engineering approach, we utilise the equations for the factory-warehouse echelon to develop a z-transform representation as in Figure 1 a). It would be extremely difficult to relate the original simulation equations to Figure 1 b), and even with a cursory glance the model of Figure 1 a), looks complicated and, from a surface similarity visual comparison, still totally different from Figure 1 b). If we now try to use control engineering criteria to have a more analytical comparison we then have Table 1. Hence, surface similarity suggests two very different systems with no analogy. Using a system simplification approach originating in hardware control engineering (Biernson, 1988) and subsequently exploited by Wikner et al. (1992), using the Laplace s-domain, to developed an equivalent linear, time

invariant representation of the Forrester (1958) decision ordering rule, we will show the analogy of Figure 1 a) with the Burns and Sivazlian (1978) of Figure 1 b).

In this way our aim is to develop an interdisciplinary approach, exploiting control engineering in an AR context, in production and inventory control system design so as to understanding the causes of the ‘bullwhip effect’, a symptom of the system's dynamics, and a precursor to its reduction / elimination. Hence we provide the basis for future research in Operational Research in providing robust and structured approaches to AR (Knott, 2006). Also, by using control engineering within an AR context we then seek to avoid the inherent dangers that a purely quantitative approach will not be usable by decision makers (Akkermans and Bertrand, 1997). We will further show the potential of our integrated approach for other general supply-chain modelling problems by applying it in a contemporary setting.

2. Control engineering design of a complex production and inventory control system using analogical reasoning

We use Gavetti and Rivkin’s (2005) suggested three steps for the development of AR in management decision making. These are;

1. Target model– the observed or current situation / problem to be addressed is identified, documented and modelled.
2. Source model(s) – through direct / indirect experience considers other settings and, through a process of similarity mapping, identifies a setting that displays similar attributes, such as archetypes and benchmarks.
3. Candidate solution(s) – from the source model an actual, or potential, benchmark solution is identified.

2.1 Target model. This is the Forrester (1961) model of the factory-warehouse echelon as given by the equations and associated notation of Appendix 1. A fuller description of the meaning of the notation can be found in Forrester (1961) and their relationship with control engineering notation in Wikner et al. (1992). The latter translate the simulation equations into causal loop diagrams before deriving the Laplace block diagram representation. Here we go directly to a block diagram representation as given in Figure 1 a), using z-transform notation to be commensurate with the modelling approach utilised by Burns and Sivazlian (1978) and others (e.g. Popplewell and Bonney, 1987). z notation has more recently been utilised in operational research, analysing the bullwhip effect induced by ordering replenishment rules whether at the unit of analysis of a single-echelon (e.g. Disney et al., 2006) or multi-stage supply chains (e.g. Agrawal et al., 2008). A fuller description of the formulation and use of block diagrams and the z-transform may be found in Nise (2011). Appendix 1 explains how the z-transform notation relates to the original simulation equations.

Simply looking at the block diagram ‘as is’ would suggest the following;

- There exist the basic building blocks for a generic system archetype; feedback, stocks and flows, policies or decision rules, and lags or delays.
- There are a number of feedback loops and delays.
- The feedback loops are monitoring systems states or the stocks in the system.
- The feedback loops influence the ordering decision, MD, that is, the manufacturing rate.
- The feedback loops are balanced, suggesting a homeostatic system, which are also suggested by running the three-echelon simulation.

If the above ‘surface similarity’ deductions are to be believed then intuitively a manager would be looking to solve the problem traditionally associated with a phase-lag, or delayed response, system and that the bullwhip solution lies with proportional control / phase-lead compensation. The relative complexity of the block diagram suggests that it will be

difficult to derive the transfer function and any quantitative analysis would have to rely on simulation alone. Also, the complexity seems quite unique, again posing difficulties to identifying analogous production and inventory control systems with potential candidate solutions.

To better grasp 'behavioural similarity' the next step is to undertake a simplification procedure in order to understand the underlying mechanisms. We follow a similar procedure as given by Wikner et al. (1992), which ensures replication of their work in the Laplace s domain using the alternate z transform method, and as given in Appendix 2. The simplification yields Figure 2.

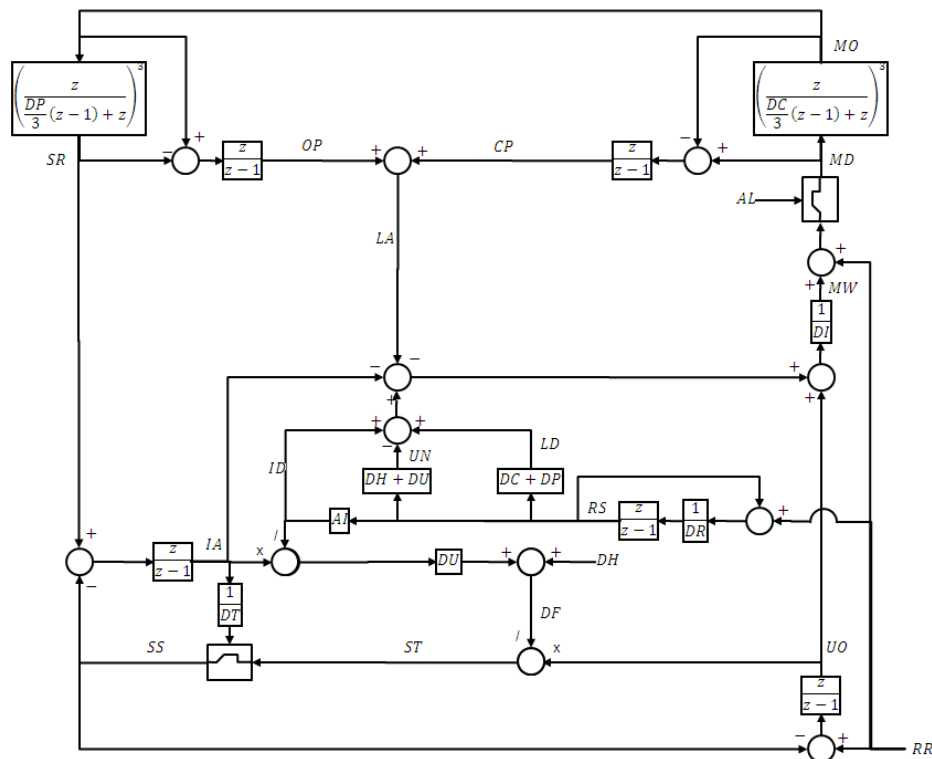

a)

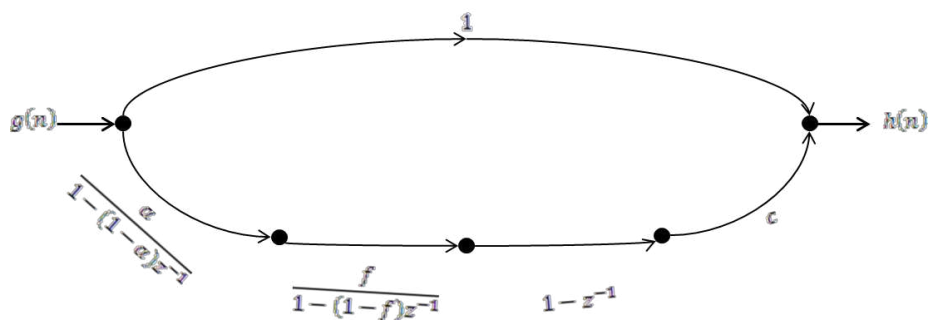

b)

Figure 1: a) Forrester (1958, 1961) model in block diagram z notation form and b) Burns and Sivazlian (1978) model - all parameters and variables will be explained later in the paper

Criteria for comparative purposes	Forrester (Figure 1a)	Burns and Sivazlian (Figure 1b)
Number of variables	17	5
Number of feedback loops	8	0
Number of parameters (total)	9	3
Number of first order lags / delays	0	2
Number of second order lags / delays	0	0
Number of third order lags / delays	2	0
Number of integrators / stocks	5	1
Number of time varying parameters	1	0
Number of continuous non-linearities	2	0
Number of discontinuous non-linearities	2	0
Ease of transfer function formulation	Low	High

Table 1: Control engineering comparison of the two systems shown in Figure 1.

If required, we can reinstate other variables of interest, such as IA or SS, but for the purposes of identifying the target model herein and the subsequently identified source model then Figure 2 highlights the relationship of interest, $\frac{MD}{RR}$. It can be clearly seen from Figure 2 that the system contains no linear state feedback in the ordering rules which consists of two components; the actual orders received, RR and a safety component, $RR \cdot \frac{Kz(z-1)}{(DR(z-1)+z)(DI(z-1)+z)}$. That is, the system states, given by IA, inventory actual levels, and LA, pipeline orders actual in transit, do not affect the ordering rule and hence have no impact on the ‘bullwhip effect’. Without this insight, considerable time and effort may be wasted by decision makers on exploring, say through protracted System Dynamics simulation studies, the impact of reducing pipeline lead-times and/or adjusting inventory feedback rules on the ‘bullwhip effect’.

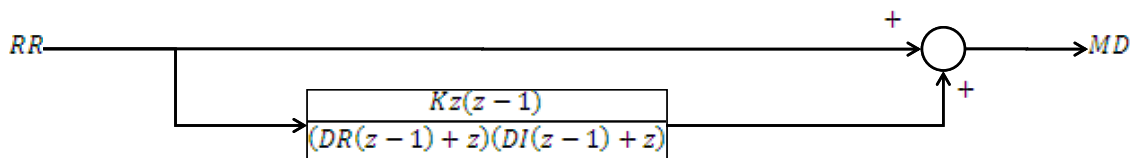

Figure 2. The z-transform simplified representation of the Forrester (1958) model.

2.2 Source model. Here we note that the block diagram of Figure 2 and the principle of ‘real’ plus ‘safety’ orders has direct analogy with the model developed and analysed by Burns and Sivazlian (1978). While Burns and Sivazlian

(1978) used a flow graph and different notation ($Z=z^{-1}$), as in Figure 1 b), Figure 3 a) shows the equivalent block diagram representation.

The terms used in Figure 3 a) are; $h(n)$ = order placed in week n, $g(n)$ = order received in week n, c = number of weeks of inventory ownership desired, f = hedging coefficient

Immediately it can be seen that Figure 3 a) resembles Figure 2 in that the order decision, $h(n)$, consists of two components. The upper path is the order received, $g(n)$, while the lower path is an additional component that aims to compensate for lags in the system and adjust inventory. The lower path consists of a number of functions that are, in order from left to right: exponential smoothing, with parameter α ; a second exponential smoothing function, with parameter f ; differencing; and a constant, c . Hence we can immediately deduce that there is ‘surface similarity’ between the Burns and Sivazlian (1978) model and simplified Forrester model of Figure 2.

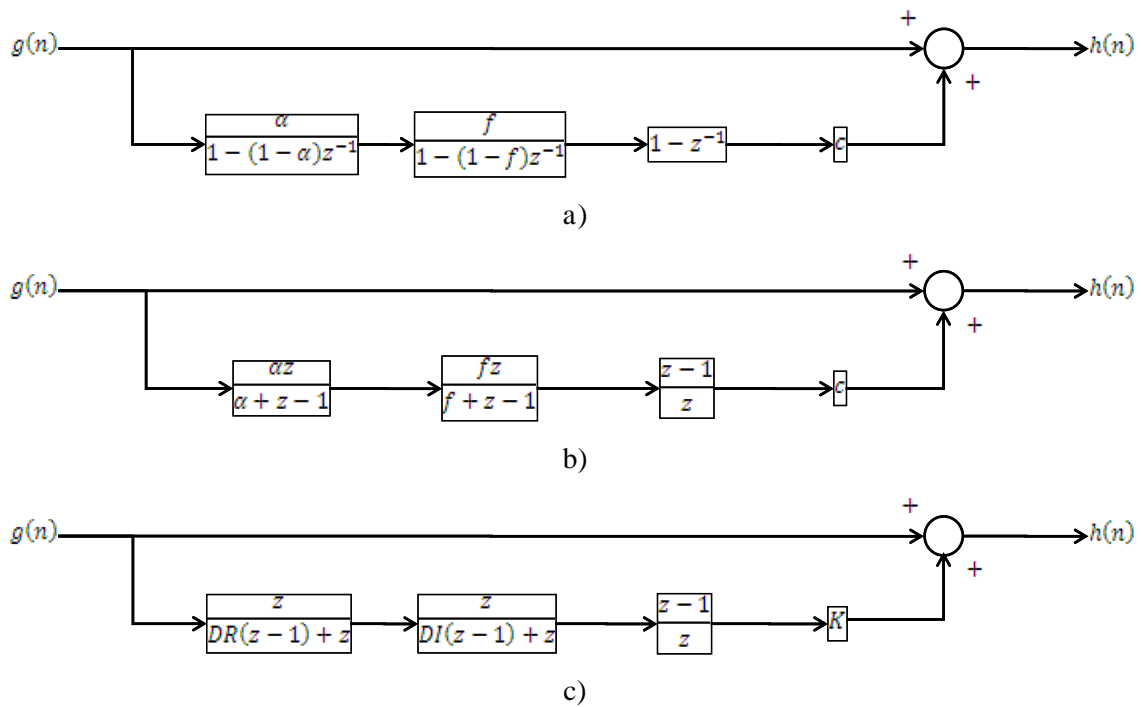

Figure 3. The Burns and Sivazlian (1978) model a) and its rationalisation, via b), to the model equivalent c)

Figure 3 b) is the manipulation of the functions to get them in the form of z rather than z^{-1} . Then, making the following correlations between terms used in Figures 2 and 3;

$$\alpha = \frac{1}{1 + \frac{DR}{\delta t}} \quad \dots(1)$$

$$f = \frac{1}{1 + \frac{DI}{\delta t}} \quad \dots(2)$$

$$c = K \quad \dots(3)$$

$$\delta t = 1 \quad \dots(4)$$

we derive Figure 3 c) which can be further reduced to be exactly equivalent to Figure 2.

This is an important result. We have now found ‘behavioural similarity’ between the Burns and Sivazlian (1978) model and the Forrester model (1961). The AR would not have been identified if the original Forrester model had been retained

especially in the form of the simulation equations of Appendix 1 and even in the form of the original block diagram as shown in Figure 1 a).

Triangulating analytical approaches to verify the similarity between the Forrester (1961) and Burns and Sivazlian (1978), models, Figure 4 a) shows the MD unit step response comparison between the Wikner et al. (1992) and Forrester (1961) block diagram unit step responses using the MATLAB Simulink[®] software package, and the Wikner et al. (1992) / Burns and Sivazlian (1978) model inverse z-transform into the time domain using the Mathematica[®] software package.

The derived transfer function is

$$\frac{MD}{RR} = \frac{z^2(DR \cdot DI + DR + DI + K) + z(-2DR \cdot DI - DR - DI - K) + DR \cdot DI}{z^2(DR \cdot DI + DR + DI) + z(-2DR \cdot DI - DR - DI) + DR \cdot DI} \quad \dots(5)$$

For the parameter settings established in the original Forrester (1961) simulation tests, i.e. $K = 9$, $DR = 8$, $DI = 4$, the unit step responses are exact. This indicates that in the original Forrester model, for the value of AL used, the non-linearity established by the CLIP function never constraints MD. Figure 4 b) shows the IA deviation step response for the original Forrester model, which has DF as a time varying parameter, and compare it with the Wikner et al. (1992) model which can only be calculated by reinstating MO, SR, UO and ST. Also shown is the Forrester model with time varying parameters kept fixed and the non-linearity set by the CLIP function set at such a high level that it does not constrain SS. It can be seen that the latter directly mimics the Wikner et al. (1992) / Burns and Sivazlian (1978) model.

Figure 4 therefore suggests that even the time varying feedback that is present does not affect the ordering decision MD and hence does not influence the bullwhip effect. This is true also when the non-linearity also constrains SS.

2.3 Candidate solution. Our simplification in Section 2.1 and analysis in Section 2.2 now suggests the following properties associated with the Forrester model;

- There is no significant feedback into the ordering decision, MD
- There is a differencing term in the numerator of the transfer function which is the cause of the bullwhip effect and not any linear feedback loops.
- We should expect a phase-lead and not a phase-lag system
- It is easy to derive the transfer function. Hence, the model is mathematically tractable with simulation as support.
- The Forrester model has ‘surface similarity’ and ‘behavioural similarity’ with the Burns and Sivazlian (1978) model. Hence, a candidate solution will be found in Burns and Sivazlian (1978).

Burns and Sivazlian show selected unit step, random and sinusoidal responses to highlight the dynamic behaviour of one-, two- and six-echelon systems, which exhibit the ‘bullwhip effect’. Using numerical frequency response analysis they suggest a filtering approach so as to filter out unwanted ‘false orders’ in the lower path of Figure 3 c) while allowing ‘legitimate orders’ to pass through. The ‘false order’ is created by the differencing term, $\frac{z-1}{z}$, a form of forecasting based on the rate of change. In hardware control engineering terms this generates the well-known “phase advance”, or predictive component (Truxal, 1955). While this has advantages when it comes to inventory replenishment, in essence ordering in advance to ensure stock availability, we now see that there must be some constraint (Porter 1952).

We do not replicate the analysis already undertaken by Burns and Sivazlian (1978). Instead we show the frequency response of the system graphically using discrete time bode plots given in Figure 5 which are based on the case when $c = 9$, $\alpha = 0.111$, $f = 0.2$, i.e. again for the original Forrester test condition when $K = 9$, $DR = 8$, $DI = 4$. Burns and Sivazlian,

using a continuous-time analogue of their model, calculated the natural frequency, ω_N , corresponds to a period of $T_{\omega_N} = 2\pi \sqrt{\frac{1-\alpha}{\alpha f}}$ weeks. For the chosen parameter values, $T_{\omega_N} = 40$ weeks. It can be seen from the peak magnitude in

Figure 5 that the damped natural frequency lies between 0.1-0.2 radians week⁻¹, so that $31.5 < T_{\omega_N} < 62.8$ weeks.

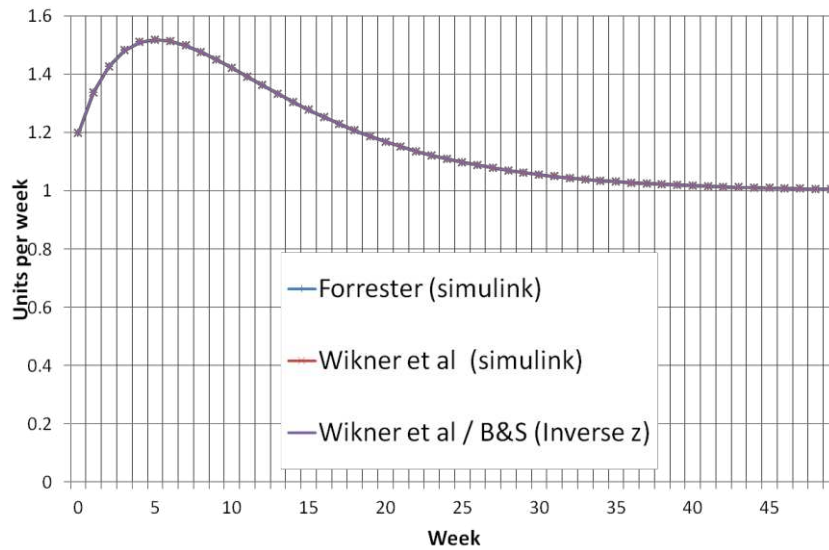

a) MD step response

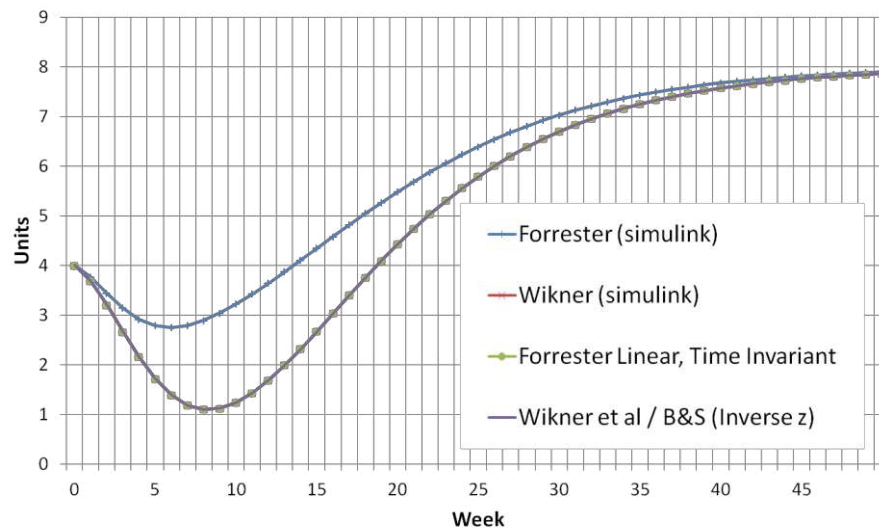

b) IA step response

Figure 4. Triangulation methods in comparing the Wikner et al. (1992) / Burns and Sivazlian (1978) and Forrester (1961) dynamic responses ($K = 9$, $DR = 8$, $DI = 4$)

The bode plot also shows that the peak magnitude corresponds with little phase lead in the output. While Burns and Sivazlian, as with other authors who have utilised filter theory in supply chain design, focussed on the amplitude ratio or magnitude characteristics of such systems (e.g. Towill & del Vecchio, 1994, Dejonckheere et al., 2002, Towill et al., 2003), due consideration of the phase shift is also needed.

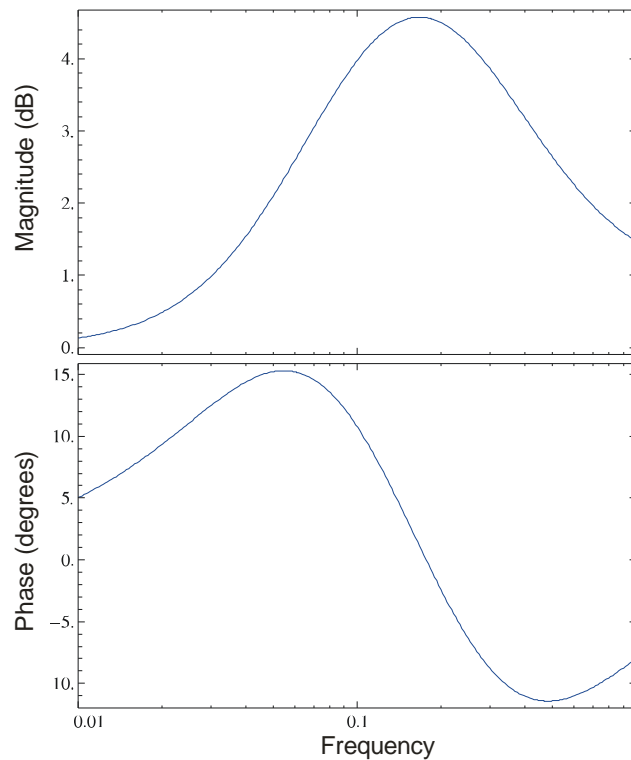

Figure 5. Bode plots of the Wikner et al.(1992) / Burns and Sivazlian (1978) models ($K = 9$, $DR = 8$, $DI = 4$)

4. Conclusion

Now we may propose an interdisciplinary framework, with control engineering at its core and exploiting analogical reasoning, for identifying the causes of the bullwhip effect, and identifying potential solutions, as given in Table 2. The approach has been tested using the Forrester (1961) supply chain as a target model. The method does not assume that an initial complicated Forrester model will lead to the right AR. By undertaking block diagram formulation, manipulation and simplification, it is possible to establish the correct ‘target model’ (simplified Forrester model) and hence identify an appropriate ‘source model’ (Burns and Sivazlian, 1978 model) from which to establish a correct ‘candidate solution’ (using filter theory).

In identifying the causes of the bullwhip effect resulting from complicated production and inventory control systems the method establishes behavioural similarity and not just surface similarity i.e. understanding the underlying mechanisms that lead to a particular dynamic behaviour.

The method developed contributes to an interdisciplinary approach as it utilises control engineering, supported by AR, to gain insights into the underlying mechanisms to system dynamics problems and providing solutions. While the research has utilised an often-quoted model to highlight the utilisation of a block diagram simplification approach, and AR a second contemporary example, namely the Intel supply chain, to test the approach suggested in this paper is given in Appendix 3. Hence, our method can be potentially used to make a bridge between theoretical and practical modelling approaches. Further empirical testing of our approach given in Table 2 is suggested for future research, especially through empirical studies as suggested in Appendix 4, which would enhance its credibility in practical problem solving situations. Such future research need not be constrained to just the bullwhip effect but should be extended to solve other supply chain dynamics phenomena such as rogue seasonality, ripple effect, inventory drift and inventory variance,

among others. Also, the development of more formal rules to compare and contrast target and source models will be of interest to the Operational Research community.

<p>Identify correct target model</p>	<p>Based on just a visual comparison between figures 1 a) and 1 b), that is merely ‘surface similarity’ comparison, there is no analogy between the Forrester and Burns-Sivazlian models. Figures 1a illustrates a complex model with several feedback loops, delays and nonlinearities, which can deceive designers into believing that the bullwhip problem is associated with a phase-lag, or delayed response ‘Behavioural similarity’, requiring block diagram manipulation and simplification, (comparing Figures 3 b and 3 c) subsequently reveals analogy between the simplified Forrester and Burns-Sivazlian models.</p>	<p>Based on just a visual comparison between Figures A3.1 and A3.3, that is merely ‘surface similarity’ comparison, there is no analogy between the Intel and IOBPCS family models. ‘Behavioural similarity’, requiring block diagram manipulation and simplification, (comparing Figures A3.3 with A3.5 and A3.6) subsequently reveals direct analogy between the Intel (pull mode) model with the VIOBPCS, but some similarity between the Intel (push mode) model with the APVIOBPCS.</p>
<p>Identify an appropriate source model</p>	<p>Without simplification it would not have been obvious that the Burns and Sivazlian’ model is analogous.</p> <p><u>Root cause for bullwhip effect:</u> first order derivative in the feedforward path</p>	<p>Without simplification it would not have been obvious that the IOBPCS family of models is analogous.</p> <p><u>Root cause for bullwhip:</u> feedback loops and delays</p>
<p>Establish a correct candidate solution</p>	<p>Surface similarity alone may have led to incorrect conclusion regarding the impact of feedback control. Behavioural similarity, revealed via simplification, gives new insights to potential solutions.</p> <p><u>Candidate solutions to bullwhip effect:</u> Filter theory, as in Burns and Sivazlian (1978).</p>	<p>Surface similarity alone may have led to over reliance on simulation alone with a trial and error approach to finding solutions to the bullwhip effect. Behavioural similarity, revealed via simplification, gives new insights to known solutions from, as well as revealing an addition to, the IOBPCS family.</p> <p><u>Candidate solutions to the bullwhip effect:</u> Conservative parameter settings from Edghill (1990) and adaptations of John et al. (1994).</p>

Table 2. An interdisciplinary framework, exploiting block diagram formulation and manipulation with analogical reasoning, for mitigating the bullwhip effect

6. Acknowledgements

The authors would like to thank Cardiff Business School's research committee for awarding an International Visitor Scheme grant allowing Prof. Wikner to co-locate with his co-authors. We would also like to thank Junyi Lin for spotting several typographical inconsistencies in our block diagrams, that are now corrected, and for his stock and flow representation of the Intel supply chain. In addition, we appreciate the considerable time and efforts of the editors and anonymous reviewers for the opportunity to develop and enhance the paper.

7. References

- Agrawal, S., Sengupta, R.N., Shanker, K. (2008). Impact of information sharing and lead time on bullwhip effect and on-hand inventory. *European Journal of Operational Research*, 192 (2), 576-593
- Akkermans, H., Bertrand, W. (1997). On the usability of quantitative modelling in operations strategy decision making, *International Journal of Operations & Production Management*, 17 (10), 953 – 966
- Biernson, G. (1988). *Principles of feedback control: Volume 2, Advanced Topics*, Chichester: John Wiley.
- Burns, J.F., Sivazlian, B.D. (1978). Dynamic analysis of multi-echelon supply systems, *Computers & Industrial Engineering*, 2 (4), 181-193.
- Croson, R. and Donohue, K. (2006). Behavioral Causes of the Bullwhip Effect and the Observed Value of Inventory Information, *Management Science*, 52 (3), 323-336.
- Dejonckheere, J., Disney, S. M., Lambrecht, M. R., Towill, D.R. (2002). Transfer function analysis of forecasting induced bullwhip in supply chains, *International Journal of Production Economics*, 78 (2), 133-144.
- Dejonckheere, J., Disney, S. M., Lambrecht, M. R., Towill, D.R. (2004). The impact of information enrichment on the Bullwhip effect in supply chains: A control engineering perspective, *European Journal of Operational Research*, 153 (3), 727-750.
- Disney, S.M., Farasyn, I., Lambrecht, M., Towill, D.R., Van de Velde, W. (2006). Taming the bullwhip effect whilst watching customer service in a single supply chain echelon. *European Journal of Operational Research*, 173 (1), 151-172
- Fisher, L. M. (2005). The Prophet of Unintended Consequences: Jay Forrester's computer models show the nonlinear roots of calamity and reveal the leverage that can help us avoid it, *Journal of Strategy and Business*, Fall (40), pp. 79-89.
- Forrester, J. W. (1958). Industrial dynamics; a breakthrough for decision makers. *Harvard Business Review*, July-August, pp. 37-66.
- Forrester, J. W. (1961). *Industrial Dynamics*. Cambridge: MIT Press.
- Gary, M. S., Kunc, M., Morecroft, J. D. W., Rockart, S. F. (2008). System dynamics and strategy. *System Dynamics Review*, 24 (4), 407-429.
- Gavetti G., Rivkin J. W. (2005). How strategists really think: tapping the power of analogy. *Harvard Business Review*, 83(4), 54-63.
- Gonzalez, C., Wong, H. (2011). Understanding stocks and flows through analogy. *System Dynamics Review*, 28 (1) 3-27.
- John, S., Naim, M. and Towill, D. (1994). Dynamic analysis of a WIP compensated decision support system, *International Journal of Manufacturing System Design*, 1 (4), 283–297.
- Knott, P. (2006). A typology of strategy tool applications. *Management Decision*, 44 (8), 1090-1105.
- Lee, H. L., Padmanabhan, V., Whang, S. (1997a). Information Distortion in a Supply Chain: The Bullwhip Effect, *Management Science*, 43 (4), 546-558.
- Lee, H., Padmanabhan, V., Whang, S. (1997b). The bullwhip effect in supply chains, *Sloan Management Review*, 38 (3), 93-102.
- Ma, Y., Wang, N., He, Z., Lu, J., Liang, H. (2015). Analysis of the bullwhip effect in two parallel supply chains with interacting price-sensitive demands, *European Journal of Operational Research*, 243 (3), 815–825.
- MacCarthy, B. L., Lewis, M., Voss, C. and Narasimhan, R. (2013). The same old methodologies? Perspectives on OM research in the post-lean age, *International Journal of Operations & Production Management*, 33 (7), 934 – 95
- Moyaux, T., Chaib-draa, B., D'Amours, S. (2007). Information Sharing as a Coordination Mechanism for Reducing the Bullwhip Effect in a Supply Chain. *Transactions on Systems, Man, and Cybernetics, Part C: Applications and Reviews*, IEEE, 37 (3), 396 – 409.
- Nise, N. S. (2011). *Control Systems Engineering*, 7th edition. John Wiley and Sons Inc., USA.
- Popplewell, K. and Bonney, M. C. (1987). The application of discrete linear control theory to the analysis and simulation of multi-product, multi-level production control systems. *International Journal of Production Research*, 25 (1), 45-56.

- Porter, A. (1952). *Introduction to Servomechanisms*, London: Methuen Press.
- Richardson, G.P. (1991). *Feedback Thought in Social Science and Systems Theory*, University of Pennsylvania Press.
- Saleh, M., Oliva, R., Kampmann, C. E., Davidsen, P. I. (2010). A comprehensive analytical approach for policy analysis of system dynamics models. *European Journal of Operational Research*, 203 (3), 673-683.
- Sharp, J. A., Price, D.H.R. (1984). System dynamics and operational research: An appraisal, *European Journal of Operational Research*, 16 (1), 1-12.
- Spiegler, V. L. M., Naim, M. M., Towill, D. R., Wikner, J. (2016). A technique to develop simplified and linearised models of complex dynamic supply chain systems. *European Journal of Operational Research*. 251 (3), 888-903.
- Towill, D. R. (1997). FORRIDGE - Principles of good practice in material flow. *Production Planning & Control*, 8 (7), 622-632.
- Towill, D. R., del Vecchio, A. (1994). The application of filter theory to the study of supply chain dynamics. *Production planning and control*, 5 (1), 82-96.
- Towill, D. R., Lambrecht, M. R., Disney, S. M., Dejonckheere, J. (2003). Explicit filters and supply chain design, *Journal of Purchasing & Supply Management*, 9 (2), 73–81
- Truxal, J. G. (1955). *Automatic Feedback Control Systems Synthesis*, New York: McGraw-Hill.
- Vassian, H.J. (1955). Application of discrete variable servo theory to inventory control, *Operations Research*, 3 (3), 272-282.
- Wang, X. and Disney, S. M. (2015). The bullwhip effect: Progress, trends and directions, *European Journal of Operational Research*, in-press.
- Wikner, J., Naim, M. M., Towill, D.R. (1992). The system simplification approach in understanding the dynamic behaviour of a manufacturing supply chain. *Journal of Systems Engineering*, 2 (3), 164-178
- Wikner, J., Towill, D. R., Naim, M. M. (1991). Smoothing Supply Chain Dynamics. *International Journal of Production Economics*, 22 (3), 231-248.
- Zhang, X., Burke, G. J. (2011). Analysis of compound bullwhip effect causes. *European Journal of Operational Research*, 210 (3), 514–526.