



Worgan, P. (2017). CoilMove: An Actuated to-body Energy Transfer System. In *Designing Interactive Systems 2017 (DIS '17): Proceedings of the 2017 Conference on Designing Interactive Systems*. (pp. 791-795). Association for Computing Machinery (ACM). DOI: 10.1145/3064663.3064693

Peer reviewed version

Link to published version (if available):  
[10.1145/3064663.3064693](https://doi.org/10.1145/3064663.3064693)

[Link to publication record in Explore Bristol Research](#)  
PDF-document

This is the author accepted manuscript (AAM). The final published version (version of record) is available online via ACM at <http://dl.acm.org/citation.cfm?doid=3064663.3064693>. Please refer to any applicable terms of use of the publisher.

## **University of Bristol - Explore Bristol Research**

### **General rights**

This document is made available in accordance with publisher policies. Please cite only the published version using the reference above. Full terms of use are available:  
<http://www.bristol.ac.uk/pure/about/ebr-terms.html>

# CoilMove: an actuated to-body energy transfer system

Paul Worgan<sup>1,2</sup>  
<sup>1</sup>MIT CSAIL  
Cambridge, USA  
pworgan@mit.edu

Mike Fraser<sup>2</sup>  
<sup>2</sup>University of Bristol  
Bristol, UK  
mike.fraser@bristol.ac.uk



Figure 1. Left: CoilMove is an actuated surface to transfer energy to the body, allowing wearable and mobile computing devices to be charged whilst remaining on the body. Middle: CoilMove transferring energy to a user's foot in one of the characterization experiments. Right: CoilMove locates devices based on the presence of a magnet and could additionally support devices resting on the surface, as well as devices on the body.

## ABSTRACT

Today, users are an integral part of charging their mobile and wearable computing devices, including smartphones, smartwatches, fitness trackers and music players. In this paper CoilMove is presented. CoilMove is an actuated wireless energy transfer system, envisaged as being embedded within a surface in a user's ambient environment, such as a floor or table. CoilMove transfers energy to devices located on the body and can recharge our mobile and wearable devices through inductive power transfer without the need for user input. CoilMove is capable of locating a device on a user's body through the presence of a magnet on the device. The user need not be aware of the interaction and from a user perspective devices would appear to charge themselves. Furthermore CoilMove is compliant with international guidelines on time-varying magnetic fields present in inductive power transfer systems, affording prolonged system use.

## Author Keywords

To-body energy transfer; actuated energy transfer; wearable charging; mobile charging; ubiquitous charging.

## ACM Classification Keywords

H.5.m. Information interfaces and presentation (e.g., HCI): Miscellaneous;

## INTRODUCTION

Currently the user plays an integral part in recharging their mobile and wearable devices. The user is asked to monitor the battery level of the device and initiate device recharging typically through a static source of energy, such as a power supply or charger plugged into the mains electrical infrastructure. We are beginning to carry and wear multiple devices including smartphones, smartwatches, cameras, fitness trackers, wireless headphones, music players, tablets and laptops. The user initiated charging model works for a small set of mobile devices; however the model does not scale well for a large number of devices, as predicted by Ubiquitous Computing. Weiser's Ubiquitous Computing vision [17] predicts a large number of small computers in our environment and potentially about our bodies. A large burden is placed on the user in terms of planning energy usage and charging these envisaged ubiquitous mobile devices. A scalable recharging methodology is required.

In the traditional model of charging, wearables seldom remain on the body to be recharged. In essence they are removed from their intended use scenario and data collection ceases whilst energy is replenished in the device's internal energy store. Allowing the device to remain on the body or *in situ* offers a chance for replenishing energy in the device, whilst maintaining device function and data collection.

Inductive energy transfer to the body takes advantage of proximity based interactions with the ambient environment to transfer energy to on- and about-body devices [18]. A transmit coil is embedded within the user's environment with a receive coil on the body. Energy is transferred when the receive coil interacts with the transmit coil's time-varying magnet field. The energy transfer can take place without requiring user input. Since the user can be unaware of the energy delivery, the device will effectively appear to

charge itself and we can classify the interaction as hidden [13]; the user need not know they are receiving energy.

Drawing on the aforementioned points, this paper presents CoilMove. CoilMove is an inductive power transfer surface affording to-body energy transfer to support mobile and wearable computing device charging *in situ*, without requiring user intervention and capable of supporting today's smartphones. Furthermore CoilMove is compliant with international guidelines on the interaction of time-varying magnetic fields with human muscle tissue, allowing the system to be operated for extended periods and “*provide protection against known adverse health effects*” [6].

### PRIOR ART

Energy in our mobile and wearable devices is an active field of research [8, 11], with commercial user initiated charging products, such as power packs, providing mobile charging on-the-go. Requiring the user to replenish the energy in our mobile devices can be a contentious issue and can even lead to device abandonment [10].

Hodges [5] argues for an invisible energy source to match Weiser's Ubiquitous Computing disappearing computing vision [17]. Hodges suggests a battery-less future supported by energy harvesting is an option to avoid burdening the user with device charging. Energy transfer from a contact based surfaced is also discussed by Hodges in the form of the Networked Surfaces project [15].

Inductive power transfer to support intelligent clothing applications has been proposed [11]. Lu *et al* [11] concentrate on the development of the electronics in their system and do not discuss how the system will be used, except to overcome metal contacts to the clothing.

Building on to-body energy transfer, MagneticMIMO [8] and MultiSpot [16], allow the user to charge a single mobile or wearable device or multiple devices respectively, whilst in proximity to an array of coils, typically installed below a table. MagneticMIMO and MultiSpot utilize the same electronic circuit, reconstructed in the LTSpice simulation shown in Figure 2, constructed from the Class D amplifier topology [9] from MultiSpot [16]. The inductance of a coil is estimated at 21.217 $\mu$ H from Wheeler's formula using the cited coil area of 0.05m<sup>2</sup> [8, 16]. The N channel MOSFETs are modelled as BSB014N04LX3 and the diodes across the source and drain as 1N5818 to obtain a peak current of 10.89 A (7.70 A RMS) through the transmit coil, L1, for an assumed DC voltage supply of 15V. A finite element method magnetics (FEMM) simulation was constructed using the MagneticMIMO and MultiSpot system for the operating frequency of 1 MHz [16] and the induced current density for human muscle tissue, conductivity of 0.503 S/m [7], at 50mm above the transmit coil was computed as 2.852 A/m<sup>2</sup>, contravening the ICNIRP 1998 basic restrictions of 2 A/m<sup>2</sup> [6]. The systems do not achieve the required 2 A/m<sup>2</sup> compliance until the tissue is 71 mm from the transmit coil, where users typing on a desk whilst operating the systems with a device about their body, will likely have their hands and arms within the 71 mm compliance distance from the transmit coil. The MagneticMIMO and MultiSpot systems are likely to contravene ICNIRP 1998 guidelines. Furthermore, both systems calculate the position of the receive device, in order to ‘steer’ the magnetic field from the transmit coil array, using the coupling between the transmit coils and receive coil. The technique performs well for receive coils with a large inductance, however if the receive coil reduces in size and inductance, for instance in small health wearables or skin based electronics [5], the transmit and receive coils reduce in coupling and locating the receive device may become problematic.

CoilMove builds on the work of Worgan *et al* [18] with an actuated energy delivery surface compliant with international guidelines on time-varying magnetic field interaction with muscle tissue. Actuating the energy transfer coil allows small radius transmit coils to be used. Confining the magnetic field to smaller areas of interaction with the body allows us to shield the tissue from time-varying magnetic fields. Additionally for local body interaction with time-varying magnetic fields the ICNIRP 1998 basic restrictions apply, ultimately allowing higher to-body energy transfers, over magnetic fields covering a significant proportion of the body. The CoilMove project asks the question “*can we utilize an actuation method to maximize energy transfer to the body, whilst maintaining compliance with international guidelines?*”.

### ACTUATED ENERGY TRANSFER SYSTEM

A natural question arising from a to-body energy transfer system is the target area of the body for energy delivery. A mobile phone could be located in a user's trouser pocket or

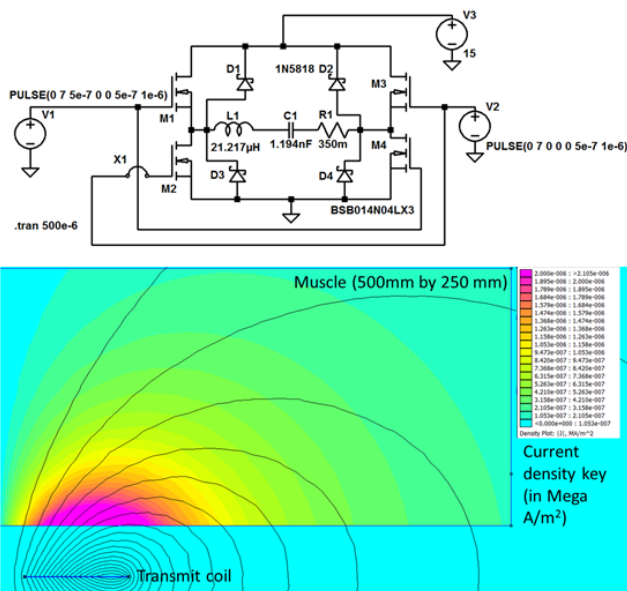

Figure 2. Upper: an LTSpice simulation of the MagneticMIMO and MultiSpot systems. Lower: A FEMM simulation to estimate the current density induced in a user's muscle tissue by the MagneticMIMO and MultiSpot systems.

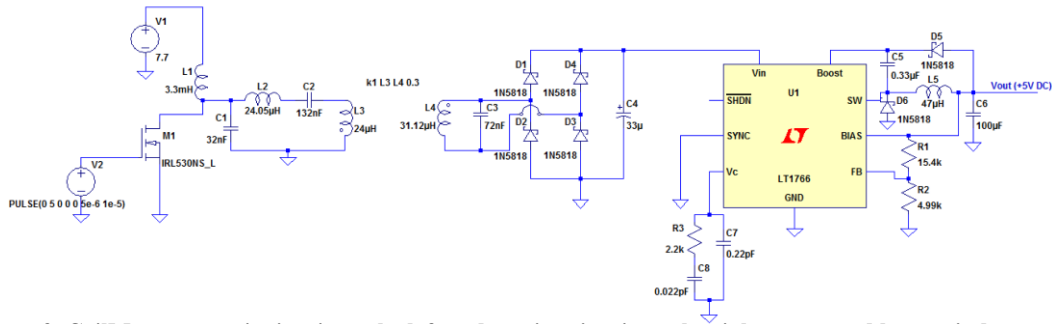

Figure 3. CoilMove transmit circuit on the left and receive circuit on the right, separated by two inductors.

a fitness wearable on a wrist. CoilMove concentrates on providing energy to a user’s foot. The foot offers an on-body location where gravity necessitates an interaction. Additionally, the floor is largely a two dimensional plane, lending itself well to inductive energy transfer from a transmit coil embedded within the floor. The temporal experiments carried out by Worgan *et al* [18] also suggest the floor would be a successful place for a to-body receive coil, with temporal interactions between 55% and 83%, over a 300 second duration for three domestic tasks. The shoe is also an area of interest for mobile computing applications including foot pressure monitoring [14] and fitness tracking [1]. Once the energy is delivered to the foot, the magnetic energy can be redistributed across the body using a garment based energy redistribution system [19], to support mobile and wearable devices on and about the body.

In our exemplar scenario of to-foot energy transfer, the design of the inductive energy transfer transmitter must be able to cope with energy transfers through a floor to the shoe. The transmit coil and receive coil will be vertically separated by at least the distance of a floor board, an operating condition not present in commercial mobile inductive charging. The vertical separation of the transmit and receive coils electrically operates the coils in a loosely coupled domain [3]. The transmit circuit has been designed for loosely coupled operation using modified design equations from Casanova *et al* [3], and the final CoilMove circuit is shown in Figure 3.

Operating a proximity based inductive to-body energy transfer system could expose the user’s tissue to time-varying magnetic fields, which can induce rotational currents, often called eddy currents, in a conductive medium, such as human muscle tissue [7]. Actuating the transmit coil is a method of localizing the magnetic field, whilst ensuring the user can be shielded from the time-varying magnetic field. The user’s tissue is shielded from the time-varying magnetic field by backing the receive coil with a low reluctance substrate; Würth 364002 flexible ferrite. Magnetic fields prefer to follow a low reluctance path and the ferrite consequently directs the magnetic field away from the tissue. The ferrite is backed with copper tape, ensuring a large proportion of the residual time-varying magnetic field is converted into eddy currents in the copper, as opposed to the biological tissue behind the receive coil.

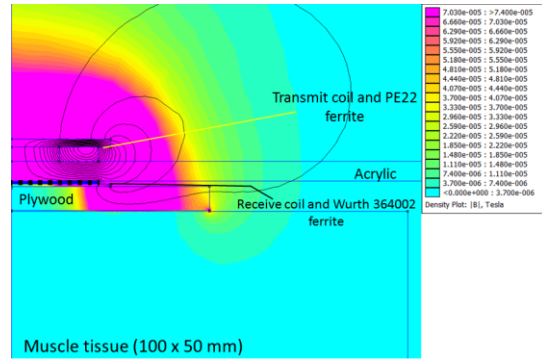

Figure 4. FEMM simulation of the CoilMove system. The deep purple regions surrounding the transmit coil show areas beneath the CoilMove surface not compliant with ICNIRP 1998 guidelines. Within the muscle tissue at the bottom, representing the foot, the region is ICNIRP 1998 compliant.

A FEMM simulation of the CoilMove system is shown in Figure 4, where an equivalent maximum magnetic field of  $80.15 \mu\text{T}$  has been calculated for ICNIRP 1998 compliance for a current density of  $0.194 \text{ A/m}^2$ , as described in Worgan *et al* [18]. ICNIRP 1998 guidelines state the maximum induced current density for compliance, with the basic restriction for the general public at the CoilMove operating frequency of 97 kHz, is  $0.194 \text{ A/m}^2$  RMS. The FEMM simulation of the shielded configuration returned a maximum induced current density of  $0.027 \text{ A/m}^2$  RMS, ensuring CoilMove complies with ICNIRP 1998 guidelines.

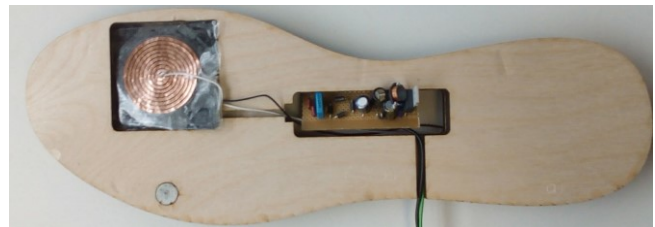

Figure 5. CoilMove ‘flip-flop’ constructed as an exemplar device for collecting energy from the surface at the foot.

The receive coil must fit and integrate into the user’s shoe. Most inductive power transfer coils are constructed from wire and fixed in a rigid shape with an adhesive to ensure a constant inductance. This makes integration of the coil with the body difficult, since a rigid coil could restrict the body’s natural range of movements. CoilMove’s receive coil utilizes a coil constructed from four layers of copper tape and configured as a 44mm diameter, 9 turn, Archimedean

spiral. The coil has an inductance of 30.32  $\mu\text{H}$  when flat. A 90° deformation causes the inductance to increase to 32.28 $\mu\text{H}$ , only a change of 1.96 $\mu\text{H}$  or 6.46%; allowing the receive circuit to remain in resonance with large deformations caused by human movement.

CoilMove’s actuation is achieved through an OpenBuilds belt driven linear actuator [12], also known as an XY table, similar to the systems used in commercial laser cutters and 3D printers. The table has a width of 1m and height of 0.5m, in order to fit under a typical office desk. The linear actuators are controlled from a CNC xPRO V2 driver board accepting GRBL commands from a MATLAB program. The transmit coil in CoilMove is attached to the moveable gantry. In order for CoilMove to transfer energy, a method of determining if a user’s foot is present and locating the foot on the surface is required. A magnet based sensing and positioning system was selected, as the receive coil on the foot can be located, even if the receiver possesses no energy. A 6mm diameter by 3mm high N42 neodymium magnet is embedded in the shoe, as shown in Figure 5. A Honeywell HMC5883L magnetometer and a Honeywell SS490 hall effect sensor, attached on the gantry alongside the transmit coil, are used to determine the magnet’s position. The magnetometer is used to determine the neodymium magnet’s location within a 120 mm radius of the gantry and the hall effect sensor is used for finer grain position determination in close proximity to the magnet. Since the magnet position can be located within a 120mm radius, the 1m by 0.5m surface is compartmentalized into 8 unique locations. The gantry is moved between each of the locations to locate and transfer energy to the receive coil in the foot. In an initial calibration step, the contribution of the Earth’s magnetic field is recorded at each of the 8 locations in each of the 3 axes, and removed when calculating the position of the magnet on the foot.

**EXPERIMENT**

CoilMove’s actuation is designed to increase the performance of transferring energy to smart devices located on the body, over a static transmit coil system. In order to assess the performance of CoilMove two experiments were conducted. The first experiment deployed CoilMove under a table, after an initial calibration procedure, for 300 seconds with 12 participants, each wearing the prototype ‘flip-flop’ shown in Figure 5, with the receive circuit charging an HTC Desire C, whilst working at a computer. The second experiment consisted of the same participants wearing the prototype flip-flop and the gantry was initially moved under the foot whilst the user adopts a comfortable seating position. During the second experiment, the gantry remained static for the 300 second experiment duration to simulate a static transmit coil and again charged the HTC Desire C, whilst working at a computer. The starting order of the experiments was alternated and for each experiment a sheet of paper covered the transparent surface. The initial HTC Desire C indicated battery level was between 56% and 62%. The direct-current (DC) voltage drawn by the transmit

circuit, DC current drawn by the transmit circuit, DC voltage delivered to the smartphone and DC current delivered to the smart phone were recorded in a CSV file at 10Hz for each experiment and participant.

Test	Mean RX I (A)	Mean TX I (A)	Mean DC-DC Efficiency (%)	Time seen (%)
Actuation	0.175	0.309	29.31	71.75
Static	0.137	0.277	25.60	51.65

**Table 1. CoilMove results for the moving and static coil experiments for the 12 participants.**

The results of the CoilMove experiments are shown in Table 1, giving the mean DC receive (RX) current, I, delivered to the smartphone, the mean DC transmit current consumed by the transmit (TX) circuit, the mean DC-DC power efficiency of the circuits and the mean percentage of time spent transmitting energy over the 300 second experiment. When operational, the transmit circuit consumed 8.83 V DC and delivered 4.57 V DC to the receive circuit.

**COILMOVE RESULTS**

The actuated CoilMove surface achieved a mean current delivery increase to the HTC smartphone of 38mA, or 27.74%, over the static condition, implying the actuated system minimized coil horizontal misalignments [18]. As a consequence of minimizing the misalignments the actuated system achieved a mean electrical power efficiency increase of 3.71% over the static condition, demonstrating CoilMove, once at the foot location, is on average more power efficient than a static system. Additionally over the experiment duration, the actuated system is active (denoted by a non-zero receive circuit current) 20.10% more than the static system, demonstrating actuated to-body energy systems provide an increased opportunity for energy transfer over static systems.

**CONCLUSION AND FUTURE WORK**

CoilMove is capable of locating and charging a to-foot energy system, for a mean time of 71.75% over 300 seconds. The CoilMove experiments demonstrated an increase of 27.74% in mean current delivered to the smartphone (0.175A at 4.57 V DC or 0.800 W DC) over the static system; enough to support common tasks such as WiFi download and MP3 audio on the Samsung Galaxy I7500 and Nexus S [2] indefinitely whilst using CoilMove in an actuated configuration.

CoilMove takes an important step in enabling energy to be delivered to the body without user intervention, whilst maintaining compliance with international guidelines on time-varying magnetic fields. Further investigation into actuated to-body energy transfer including a long term deployment and full integration into the shoe or clothing will enable a deeper insight into living with a system capable of charging our mobile and wearable devices for us.

## REFERENCES

1. Altra. Altra IQ Smart Shoe. Retrieved January 02, 2017 from <https://www.altrarunning.com/iq>
2. Luca Ardito, Giuseppe Procaccianti, Marco Torchiano, Giuseppe Migliore. 2013. Profiling Power Consumption on Mobile Devices. In *Proceedings of the Third International Conference on Smart Grids, Green Communications and IT Energy-aware Technologies (ENERGY 2013)*. 101-106.
3. Joaquin J. Casanova, Zhen Ning Low, Jenshan Lin. 2009. Design and Optimization of a Class-E Amplifier for a Loosely Coupled Planar Wireless Power System. *IEEE Transactions on Circuits and Systems II*. 56, 11. 830-834. <http://dx.doi.org/10.1109/TCSII.2009.2032465>
4. Mitul Dalal, Conor Rafferty, Yung-Yu Hsu, Henry Wei, Kevin Dowling, Briana Morey, Greg Levesque, Gil Huppert, Brian Elolampi, Dan Davis. 2013. Epidermal electronics for seamless monitoring of biopotential signals. In *Proceedings of the 2013 IEEE 63rd Electronic Components and Technology Conference*. 500–503. <http://dx.doi.org/10.1109/ECTC.2013.6575618>
5. Steve Hodges. 2013. Batteries Not Included: Powering the Ubiquitous Computing Dream. *Computer*. 46, 4 (April 2013), 90-93. <http://dx.doi.org/10.1109/MC.2013.125>
6. International Commission on Non-Ionizing Radiation Protection, Guidelines for limiting exposure to time-varying electric, magnetic, and electromagnetic fields, *Health Physics*. 74, 4. (1998). 494 – 522. <http://www.icnirp.org/cms/upload/publications/ICNIRPemfgdl.pdf>
7. IT'IS Foundation. IT'IS Foundation tissue database. Retrieved January 02, 2017 from <http://www.itis.ethz.ch/virtual-population/tissue-properties/database/tissue-frequency-chart/>
8. Jouya Jadidian and Dina Katabi. 2014. Magnetic MIMO: how to charge your phone in your pocket. In *Proceedings of the 20th annual international conference on Mobile computing and networking (MobiCom '14)*. 495-506. <http://dx.doi.org/10.1145/2639108.2639130>
9. M. K. Kazimierczuk. 1991. Class D voltage-switching MOSFET power amplifier. *IEE Proceedings B - Electric Power Applications*. 138, 6. 285 – 296. <http://dx.doi.org/10.1049/ip-b.1991.0035>
10. Amanda Lazar, Christian Koehler, Joshua Tanenbaum, and David H. Nguyen. 2015. Why we use and abandon smart devices. In *Proceedings of the 2015 ACM International Joint Conference on Pervasive and Ubiquitous Computing (UbiComp '15)*. 635-646. <http://dx.doi.org/10.1145/2750858.2804288>
11. Y. Lu , K.W.E. Cheng , Y. L. Kwok , K. W. Kwok, K.W. Chan, and N.C.Cheung. 2007. Gapped Air-cored Power Converter for Intelligent Clothing Power Transfer. In *Proceedings of the IEEE 7th International Conference on Power Electronics and Drive Systems*. 1578-1584. <http://dx.doi.org/10.1109/PEDS.2007.4487919>
12. OpenBuilds Part Store. V-Slot Linear Actuator Bundle (Belt Driven). Retrieved January 02, 2017 from <http://openbuildspartstore.com/v-slot-linear-actuator-bundle-belt-driven/>
13. Stuart Reeves, Steve Benford, Claire O'Malley, and Mike Fraser. 2005. Designing the spectator experience. In *Proceedings of the SIGCHI Conference on Human Factors in Computing Systems (CHI '05)*. 741-750. <http://dx.doi.org/10.1145/1054972.1055074>
14. Ali Saeedi, Farshad Almasganj, Malike Pourebrahim. 2014. Plantar pressure monitoring by developing a real-time wireless system. In *Proceedings of the 2014 21th Iranian Conference on Biomedical Engineering (ICBME)*. 211 – 214. <http://dx.doi.org/10.1109/ICBME.2014.7043923>
15. James Scott, Frank Hoffmann, Michael D. Adlesee, Glenford Mapp, Andy Hopper. 2000. Networked Surfaces: A New Concept in Mobile Networking. In *Proceedings of the Third IEEE Workshop on Mobile Computing Systems and Applications*. 11-18. <http://dx.doi.org/10.1109/MCSA.2000.895377>
16. Lixin Shi, Zachary Kabelac, Dina Katabi, and David Perreault. 2015. Wireless Power Hotspot that Charges All of Your Devices. In *Proceedings of the 21st Annual International Conference on Mobile Computing and Networking (MobiCom '15)*. 2-13. <http://dx.doi.org/10.1145/2789168.2790092>
17. Mark Weiser. 1999. The computer for the 21st century. *SIGMOBILE Mob. Comput. Commun. Rev.* 3, 3 (July 1999), 3-11. <http://dx.doi.org/10.1145/329124.329126>
18. Paul Worgan, Lindsay Clare, Plamen Proynov, Bernard H. Stark, and David Coyle. 2015. Inductive power transfer for on-body sensors: defining a design space for safe, wirelessly powered on-body health sensors. In *Proceedings of the 9th International Conference on Pervasive Computing Technologies for Healthcare (PervasiveHealth '15)*. 177-184. <http://dx.doi.org/10.4108/icst.pervasivehealth.2015.259139>

19. Paul Worgan, Mike Fraser. 2016. Garment level power distribution for wearables using inductive power transfer. *In Proceedings of the 2016 9th International Conference on Human System Interactions (HSI)*. 277 – 283.  
<http://dx.doi.org/10.1109/HSI.2016.7529644>