



American Society of Mechanical Engineers

ASME Accepted Manuscript Repository

Institutional Repository Cover Sheet

Cranfield Collection of E-Research - CERES

First

Last

ASME Paper Title: Analyses of the load following capabilities of Brayton helium gas turbine cycles for
generation IV nuclear power plants

Authors: A. Gad-Briggs, P. Pilidis and T. Nikolaidis

ASME Journal Title: Journal of Nuclear Engineering and Radiation Science

Volume/Issue Vol. 3, Iss. 4 Date of Publication (VOR* Online) 31.7.2017

ASME Digital Collection URL: <http://nuclearengineering.asmedigitalcollection.asme.org/article.aspx?articleid=2632239>

DOI: 10.1115/1.4036983

*VOR (version of record)

Analyses of the Load Following Capabilities of Brayton Helium Gas Turbine Cycles for Generation IV Nuclear Power Plants

A. Gad-Briggs
a.a.gadbriggs@cranfield.ac.uk

P. Pilidis
p.pilidis@cranfield.ac.uk

T. Nikolaidis
t.nikolaidis@cranfield.ac.uk

Gas Turbine Engineering Group,
Cranfield University, Cranfield, Bedfordshire, MK43 0AL U.K.

Abstract

The control system for Generation IV Nuclear Power Plant (NPP) design must ensure load variation when changes to critical parameters affect grid demand, plant efficiency and component integrity. The objective of this study is to assess the load following capabilities of cycles when inventory pressure control is utilised. Cycles of interest are Simple Cycle Recuperated (SCR), Intercooled Cycle Recuperated (ICR) and Intercooled Cycle without recuperation (IC). Firstly, part power performance of the IC is compared to results of the SCR and ICR. Subsequently, the load following capabilities are assessed when the cycle inlet temperatures are varied. This was carried out using a tool designed for this study. Results show that the IC takes ~2.7% longer than the ICR to reduce the power output to 50% when operating in Design Point (DP) for similar valve flows, which correlates to the volumetric increase for the IC inventory storage tank. However, the ability of the IC to match the ICR's load following capabilities is severely hindered because the IC is most susceptible to temperature variation. Furthermore, the IC takes longer than the SCR and ICR to regulate the reactor power by a factor of 51 but this is severely reduced, when regulating NPP power output. However, the IC is the only cycle that does not compromise reactor integrity and cycle efficiency when regulating the power. The analyses intend to aid the development of cycles specifically Gas Cooled Fast Reactors (GFRs) and Very High Temperature Reactors (VHTRs), where helium is the coolant.

Keywords: Gen IV, Efficiency, NPP, Cycle, Part Power, Performance, Simple, Intercooled, Inventory, Control.

Nomenclature

Notations

CW	Compressor Power (W)
m	Mass Flow Rate (kg/s)
$NDMF$	Non-Dimensional Mass Flow
Q	Reactor Thermal Power (W)
P	Pressure (Pa)
PR	Pressure Ratio
SW	Specific Work (J/kg s)
T	Temperature (K or °C)
TW	Turbine Power (W)
W	Power (W)
UW	Useful Power/Power Output (W)

Greek Symbols

Δ	Delta, Difference
η	Efficiency

Subscripts

t	Thermal Power
th	Thermal Power

Abbreviations

C	Compressor
CH	Precooler

CIT	Core Inlet Temperature
COT	Core Outlet Temperature
CV	Control Valve
DP	Design Point
GEN IV	Generation IV
GFR	Gas-Cooled Fast Reactor
HE	Recuperator
HP	High-Pressure
HPC	High Pressure Compressor
IC	Intercooled Cycle, Intercooler
ICR	Intercooled Cycle Recuperated
LP	Low-Pressure
LPC	Low Pressure Compressor
NPP	Nuclear Power Plant
ODP	Off-Design Point
OPR	Overall Pressure Ratio
R	Reactor
SCR	Simple Cycle Recuperated
T	Turbine
TET	Turbine Entry Temperature
VHTR	Very High Temperature Reactor

Introduction

One of the main focuses of Generation (Gen) IV Nuclear Power Plants (NPPs) design is the load following capabilities of the control systems to meet grid demand schedules, maintain efficiency and minimise thermal

stresses in the reactor. Minimising reactor thermal stresses is an inherent stipulation in the safe and reliable operational strategy, which is critical to Gen IV system development. Deriving better plant efficiencies at Design Point (DP) and Off-Design Point (ODP) for equilibrium performance underpins the economics. The objective of this study is to demonstrate the load following capabilities of the cycles when using inventory pressure control to manage NPP power output and reactor thermal power including assessing the effects on cycle efficiency. A set of control strategies were recommended as part of this research work and is documented in [1]. The intent is for this study to be aligned with the applicable strategies. The cycles of interest are the Simple Cycle Recuperated (SCR), Intercooled Cycle Recuperated (ICR) and the Intercooled Cycle (IC) without recuperation. They were analysed in a closed Brayton direct configuration using helium as the working fluid.

Generation IV (Gen IV) Systems

The Gas-Cooled Fast Reactors (GFRs) and Very-High-Temperature Reactors (VHTRs) are the focus of this study. GFR relies on helium as the coolant and working fluid. It utilises a fast spectrum with nuclear core high temperature reactor that has a Core Outlet Temperature (COT) of between 850-950°C. The configuration is based on an efficient Brayton cycle design. The advantages of helium include singular phase cooling in all circumstances, chemical inertness and neutronic transparency [2]. The VHTR is also cooled by helium in the gaseous phase and employs a high temperature thermal reactor with graphite moderation capability in solid state. The mechanical properties of graphite at high temperature make it a good choice for moderation. The advantage of helium as a chemical inert gas is fundamental to this reactor configuration because it ensures that there is no chemical reaction with the graphite moderator. There are planned and on-going development projects for the GFR and VHTR. These projects relate to testing of basic concepts and performance phase validation. These demonstrators are discussed in [3].

Applicable Cycles

All three cycles of interest are described extensively in [4] and are illustrated in figures 1, 2 and 3. All cycles have the compressor (C) and turbine (T) as part of the turbomachinery, the precooler (CH) and reactor (R). The main physical difference between the IC and the other two cycles is that the IC does not employ a recuperator (HE) to provide heat exchange from the turbine outlet hot gas to the High-Pressure (HP) coolant. Temperature increase is achieved in the IC by employing a High Pressure Compressor (HPC), which delivers a higher proportion of the Overall Pressure Ratio (OPR). This is not the case for the ICR because the compressors both deliver even

pressure rises for the given Pressure Ratio (PR). An intercooler (IC) upstream of the second compressor is also employed in the ICR and IC, which reduces the inlet temperature into the second compressor to the same as the cycle inlet temperature (T_1). Another notable difference is their respective plant cycle performances. The ICR and the IC improve the specific work and useful power by reducing the compressor power. For the ICR, this translates into an increase of ~3% in comparison to SCR and an increase of 6.6% in comparison to the IC when optimised turbine cooling methods are utilised [4]. A big disadvantage of the ICR is the increased capacity of the plant due to additional components, which adds complexity to the plant configuration. The IC on the other hand, presents a simpler prospect in component configuration and is capable of COTs in excess of 1000°C, which will significantly improve the efficiency of the cycle therefore making it competitive. The benefits of changing from air to helium including the thermodynamic consequences, have been extensively covered in [5], [6] and [7]. The papers provide good theoretical bases for off-design operation, control and transient operational modes of a helium nuclear gas turbine plant.

Control Systems Strategy and Design

It is acknowledged that current operational strategies involve the use of fossil fuel plants to meet peak load, whilst NPPs are mostly utilised for base load. However, NPPs need to demonstrate part load operational capability to meet grid demand and eliminate the negative impact on the environment by displacing polluting energy sources. Control strategies are discussed in detail in the preceding paper [1] to this study, as part of this research work. Thus, the focus of this paper is on strategies, which are required to meet grid demand, maintaining reactor thermal power and high cycle efficiencies in ODP operation. These are described below:

1) Power Regulation based on Precooler Outlet/Compressor Inlet Temperature

The coolant temperature at the precooler outlet/compressor inlet affects the performance of the cycle and causes load variation at the generator including affecting the cycle performance. The control system is required to regulate the inventory within the cycle to meet the optimum equilibrium Off-Design Point (ODP) operation for power output, whilst upholding reactor core mechanical integrity.

2) Constant Thermal Power of the Reactor during Operation

The thermal power is the product of the coolant mass flow rate, the specific heat at constant pressure for helium and the delta between the core inlet and outlet temperatures. Changes in temperature at the outlet of the

precooler/compressor inlet would result in fluctuations of the reactor thermal power. The control system is required to regulate the inventory within the cycle, whilst maintaining constant COT and OPR, in order to regulate the reactor thermal power.

3) Maintaining High Efficiency during Load Following and Part Power Operations.

The efficiency of the plant remains the most critical of requirements from an economical stance. The control system must function to ensure the NPP is operated at the equilibrium ODPs if changes are observed in inlet temperature, whilst maximising efficiency and optimising the turbine and reactor cooling at those conditions. The key here is to define the settings for regulating the inventory in accordance with the ODP for power output, but without changes to the OPR and COT. For optimised turbine cooling, the study documented in [4] explains how the cooling can be optimised by utilising the blade metal temperature in calculations.

Inventory Pressure Control Design

For the aforementioned strategies, inventory pressure control is implemented for steady regulation in this study. Regulating the mass flow rate varies the pressure levels in the helium circuit, without changing the speed settings or the OPR of the compressors. Thus the regulation takes place down stream of the compressor(s). The preceding study documented in [1], mathematically demonstrated that the power output regulation is almost linear to the flow, up to a certain level due to the changes in working fluid density.

Inventory pressure control requires a storage tank, where helium is delivered to for part power performance and released from, if the power needs to be increased [1]. The flow is controlled using valves (CV) to an acceptable limit. Figure 4 shows a simplified schematic of the SCR with inventory control. There are two methods of utilising inventory control. The first method removes the helium and transfers it into the tank using CV1 downstream of the compressor; this reduces the power. For power increase, the helium is returned back to the cycle at the inlet to the precooler via CV2. A disadvantage is the returned helium momentarily increases the cycle pressure, thereby reducing the speed. This instability can be avoided if the helium is returned to the HP side of the cycle (CV4), which has the opposite effect and is favourable for the modelling in this study. In reality, the drawback is the second method requires a compressor when removing the helium from the circuit via CV3, to ensure that the helium is always at a higher pressure than the cycle, which the IC poses challenges due to the very high pressure downstream of the HPC. It is also not recommended to return it upstream of the second compressors for the ICR and IC due to aerodynamic stability of the second compressor unless the

flow is minimised to allow operation below the surge line [8]. The inventory management in [8] analysed smaller multiple storage tanks to avoid charging of all the pressure in a single tank, thus reducing the amount of pressure required to maintain the storage pressure. However, this study is not concerned with the inventory arrangement but rather the performance of the cycle. The modelling in this study assumes the inventory is being returned downstream of the compressor(s) but in reality, the first method is recommended to avoid complex arrangements.

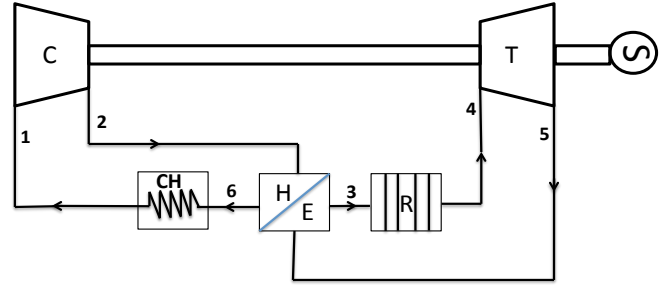

Figure 1 – Typical Simple Cycle with Recuperator (SCR) [9]

Modelling of Nuclear Power Plants and Performance Simulation Tool

Figures 1, 2 and 3 respectively illustrate typical schematics of the SCR, ICR and the IC respectively. Table 1 provides the key DP values for modelling, using the FORTRAN based modelling and performance simulation tool designed specifically for this study. With regard to DP performance, the tool has been designed to calculate the mass flow rate, temperature and pressures for each component based on known cycle inlet conditions. This enables the output and cycle efficiency to be derived. The tool can also analyse the effects on cycle output, capacity and efficiency by investigating changes in parameters. The baseline model is fully described in [4], [10], [11].

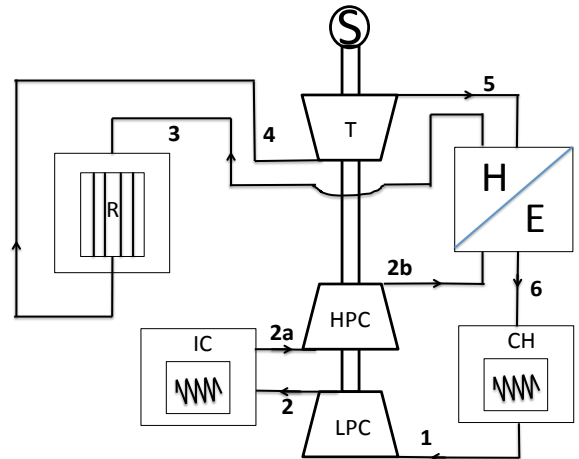

Figure 2 – Typical Intercooled Cycle with Recuperator (ICR) [12]

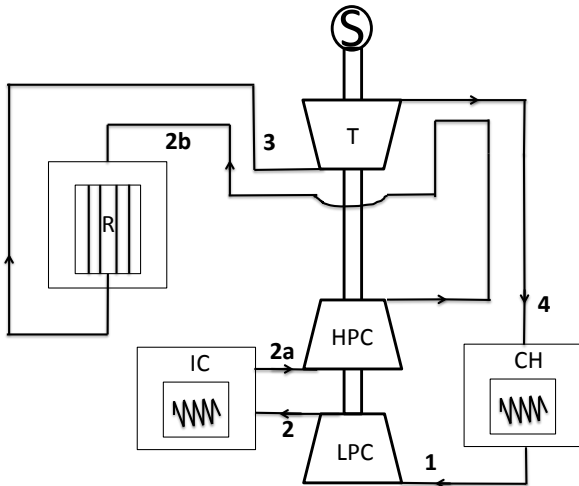

Figure 3 – Typical Intercooled Cycle without Recuperator (IC)

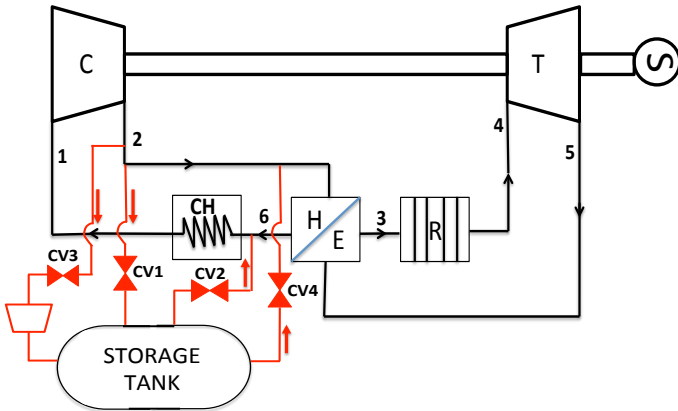

Figure 4 –Simple Cycle with Recuperator (SCR) with Inventory Pressure Control Schematic

When focusing on ODP performance, the model encompasses the turbomachinery component maps, which are represented as polynomials within the model. The process of calculation is iterative because a state of equilibrium for all components is required for successful matching. The equations and processes are described in greater detail in [13] [14]. With regard to demonstrating the capabilities for steady state and transient inventory pressure control, the model debits and credits the flow at the subject stations. For transient conditions, the calculations are repeated to represent incremental changes of the mass flow rate (kg/s) to simulate the control method. The approach was considered satisfactory for the analysis conducted in this study. The equations implemented within the code environment are described in the preceding paper to this study in [1]. It is worth remembering that IC does not have a recuperator, thus the calculations for the recuperator do not apply.

Table 1 – DP Performance for all the Cycles

Design Point Performance	SCR	ICR	IC	Units
Inlet Temp. (T_1)	28	28	28	°C
TET (Core Outlet Temp) (T_4)	950.0	950.0	950.0	°C
Core inlet temp (T_3)	678	599	448	°C
Inlet Pressure (P_1)	3.21	3.21	3.21	MPa
OPR	2	2.6	13	-
Mass flow rate at inlet (m_1)	410.4	410.4	410.4	kg/s
*Compressor Efficiency (Isentropic)	90	90	90	%
*Turbine Efficiency (Isentropic)	94.5	94.5	94.5	%
*Recuperator Effectiveness	96	96	-	%
Pressure Loss (Precooler)	2.5	2.5	2.5	%
Pressure Loss (Intercooler ICR only)	-	2.5	2.5	%
Pressure Loss (Reactor)	2	2	2	%
Pressure Loss (Recup. HP side)	6	6	-	%
Pressure Loss (Recup. LP side)	combined	combined	-	%
Reactor Cooling flow (% of Mass flow rate)	0.25	0.25	0.25	%
Compressor Power	227	299	1063	MW
Turbine Power	512.8	686.8	1537	MW
Reactor Thermal Power	575.6	743.7	1040	MW
Specific Work (NPP Capacity)	0.7	0.95	1.16	MJ/kg s
Useful Power	285.7	387.9	474.4	MW
Plant Efficiency	49.6	52.2	45.6	%

*Based on technological improvements in [15]

Results and Discussion

Transient Part Power and Efficiency Performance

Figure 5 illustrates the transient part power performances of all cycles. The results of the IC have been included with results for the SCR and ICR, which was taken from [1]. The results are based on the cycles operating in DP conditions (Table 1). The withdrawal flow rate was set to an average of 0.13 kg/s, based on studies whereby 2 different flow rates (0.09 and 0.18 kg/s) were utilised as described in [16]. The results at 50% part power show that IC is comparable to the ICR when conditions are at design point. The SCR took 9 minutes 27 seconds to achieve a 50% reduction in comparison to the ICR, which took 19 minutes 8 seconds; with the IC taking 19 minutes 39 seconds to achieve the same part power. The IC withdrawal performance is 108% longer than the SCR and 3% longer than the ICR. This also illustrates the volumetric up-scaling that is required for the storage tank of the ICR and IC. This upscale takes into account the complete removal of the inventory from the cycle in emergency conditions. The reason for the doubled time is indicated in the capacity of both plants. The capacity which is indicated by the SW is reduced by 0.16 MJ/kg s from DP for the SCR; the ICR is reduced by 0.21 MJ/kg s; the IC by 0.25 MJ/kg s. The IC had a bigger reduction of 0.09 MJ/kg s than the SCR and 0.04 MJ/kg s than the ICR to meet the power demand, primarily due to the amount of the inventory removed. The

% reduction in Compressor Power (CW) and Turbine Power (TW) are matched for all cycles. As stated in [1], it is expected that the inventory pressure control will be limited to no less than 50% part power operation by NPP operators. Any attempts to increase the flow rate must consider the aerodynamic stability of the compressors. The HPC of the IC is the most susceptible to any conditions that will lead to instabilities due to the very high pressure. It is an important consideration in order to avoid surges.

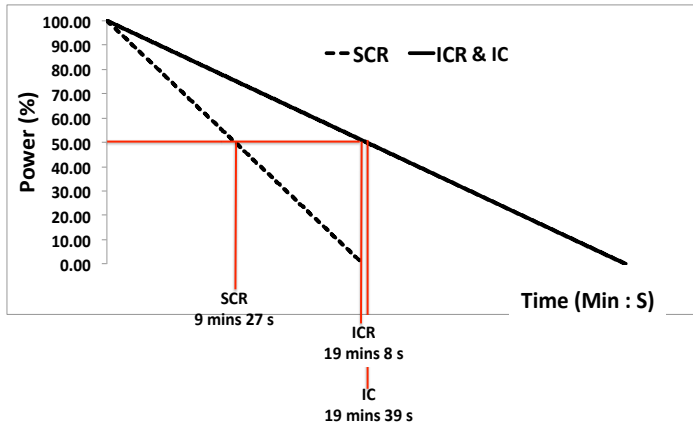

Figure 5 –Part Power Performance – (T_1) @ (DP)

Figure 6 illustrates the performance curves of all the cycles when helium is extracted during DP operations (Table 1). The flow rate for the withdrawal of helium was set at an average of 0.13 kg/s. The results of the IC have been included with the results of the SCR and ICR, which were taken from [1]. At the 50% part power level, the plant cycle efficiencies are reduced by ~22% to 38.5% for the SCR and 40.9% for the ICR. The IC had reduced by ~20% to 36.3%. When the power is reduced to 80% of full power, the SCR plant cycle efficiency had reduced by 6.7% to 46.33%; the ICR had reduced by 6.4% to 48.8% and the IC had reduced by 6% to 43%. When at 90% of full power, the SCR plant cycle efficiency had reduced by 3% to 48.2%; the ICR had reduced by 2.9% to 50.7% and the IC by 2.7%. The IC has the least degradation in efficiency for the same rate of withdrawn inventory, with the ICR having the highest rate amongst the three cycles when reduced from 100% to 50% part power. The plant cycle efficiency drops between 90% to 80% of full power are encouraging for part power performances because the efficiency drops are not severe for ODP operation. Operating for very long periods at power settings of ~50% are not recommended in order to maximise efficiency for economic purposes. Furthermore, pressure losses need to be minimised and recuperator effectiveness needs to be maximised to reduce the effect on efficiency [1], [14] and [15]. Whereby the recuperator, reactor and intercooler pressure losses and T_1 temperature are different from DP, then the NPP would need to be regulated based on the pre-determined ODP

mass flow rates defined for equilibrium operations. This will be similar to those defined in [13], [14] and will be important for the economics of the plant.

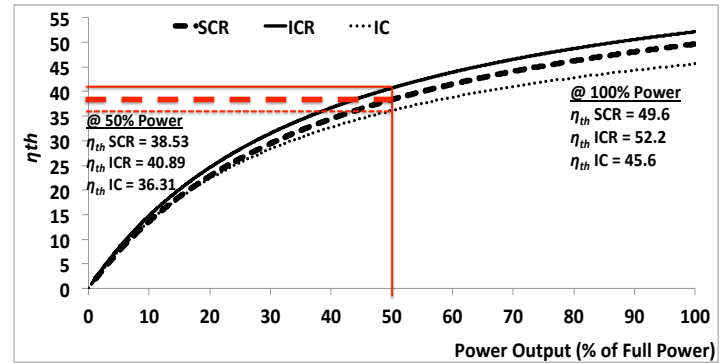

Figure 6 – Part Power versus Efficiency Curves

Load Following Operations to Maintain Reactor Power

The purpose of this analysis is to compare the time taken for the various cycles to respond to changes in pre-cooler outlet/compressor inlet temperature (T_1) in order to maintain reactor thermal power to within a tolerance of ± 0.1 MW_{th}. This also includes understanding the effects on other parameters when the control system handle prioritises reactor thermal power. It does not consider other aspects of the reactor design. The temperature range is -30°C to 50°C, with the DP inlet temperature being 28°C (see Table 1). The inventory flow rate is unchanged from previous analysis. Studies conducted in [16] discuss the effects of varying cycle inlet temperature. Figure 7 compares the SCR and the ICR; figure 8 shows all 3 cycles including the IC. With regard to figure 7 and at a cycle inlet temperature of 50°C, the SCR takes 11 seconds from the point of flow regulation to achieve the DP reactor thermal power, whereas the ICR takes 15 seconds. With regard to the IC (figure 8), it takes 6 minutes 46 seconds (406 seconds). When the cycle inlet temperature is -30°C, the SCR takes 19 seconds, the ICR takes 27 seconds and the IC takes 11 minutes 52 seconds (712 seconds). The above analysis considers an unrealistic scenario where a sudden increase or decrease in temperature occurs from 28°C to 50°C or from 28°C to -30°C respectively. However, it is used to show the cumulative time (28°C being the starting point) and to demonstrate that the IC is more susceptible to temperature changes in comparison to the SCR and the IC. In reality, temperature increases will be slow thus, Table 2 shows the time taken per 5°C incremental change. It is evident from Table 2 that the SCR can regulate the reactor thermal power to within 2 seconds from the point of flow activation to final inventory exchange. The ICR can regulate the flow to within 3 seconds in all but one instance, where 6 seconds was recorded. The IC shows an interesting trend, which is illustrated in figure 9. At

excessively high and extremely low inlet temperatures, the IC requires greater amount of inventory to effect a change in comparison to DP and means more time at these conditions. The reason for the trend observed in the IC is demonstrated in Table 3. Table 3 shows the conditions at 4 different inlet temperatures at the reactor inlet for the IC and the ICR; the SCR is comparable to the ICR as shown in figure 8 thus no additional comparison was needed.

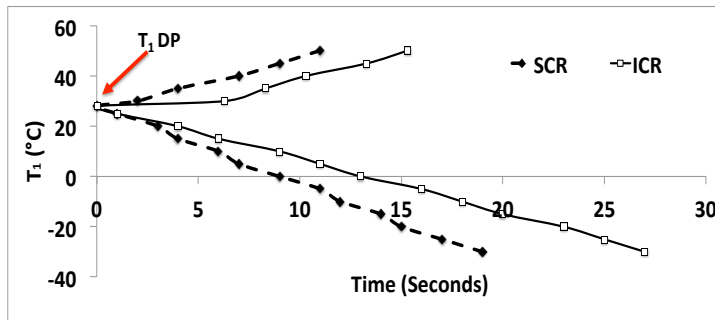

Figure 7 –Transient Perf. of SCR & ICR

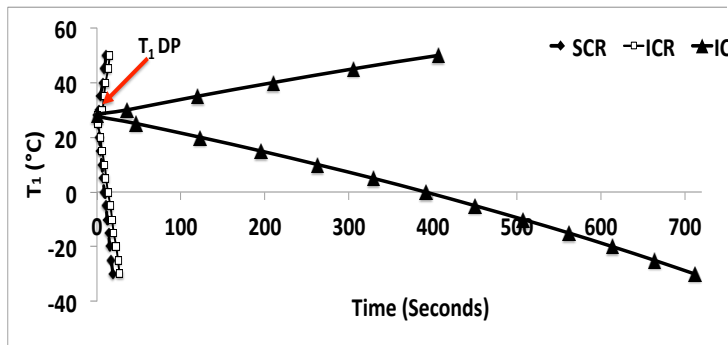

Figure 8 –Transient Perf. of SCR, ICR & IC

It can be noted in Table 3 that the values of mass flow rate, pressures and temperatures at inlet to the reactor for the ICR are comparable (i.e. negligible differences) across the T_1 values analysed. However, this is not the case for the IC, whereby increases in T_1 have a positive correlation with increases of temperature and mass flow rate at inlet to the reactor in order to meet the reactor thermal power. The recuperator in the SCR and ICR ensures that the exchange of heat from the hot gas onto the cold coolant minimises the changes.

Table 2 – Transient Performance Values

Temp. Range (°C)	IC Time (s)	ICR Time (s)	SC Time (s)
45 to 50	101	2	2
40 to 45	95	3	2
35 to 40	90	2	3
30 to 35	84	2	2
28 to 30	36	6	2
25 to 28	47	1	1
20 to 25	76	3	2
15 to 20	72	2	1
10 to 15	68	3	2
5 to 10	66	2	1
0 to 5	62	2	2
-5 to 0	59	3	2
-10 to -5	57	2	1
-15 to -10	55	2	2
-20 to -15	52	3	1
-25 to -20	50	2	2
-30 to -25	48	2	2

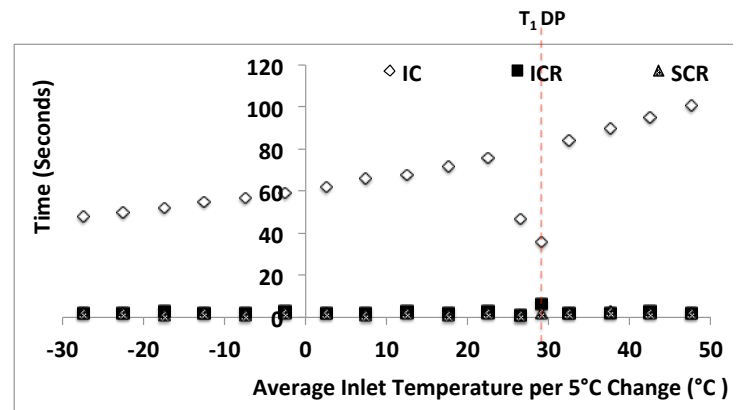

Figure 9 – Transient Performance Values (Graph)

Table 3 – Performance Values at Reactor Inlet

IC			
T1 (°C)	m (kg/s)	T (°C)	P (MPa)
10	376.2	405	40.87
20	394.4	429	40.97
30	415.1	454	40.94
40	437.7	478	40.95

ICR			
T1 (°C)	m (kg/s)	T (°C)	P (MPa)
10	409.2	597	8.05
20	409.9	597	8.05
30	411.2	598	8.05
40	411.7	599	8.05

The HPC PR remains constant in the IC meaning maintaining constant reactor power is only possible by injecting more helium. Tables 4 and 5 show the effect of maintaining the reactor thermal power on the NPP power output and the efficiencies of the cycles respectively. With regard to the effect on the NPP power output, it is clear that the IC power output does not drop as a result of maintaining the reactor thermal power. Furthermore, the variation in power within the analysed temperature range does not exceed $\pm 5\%$ and indicates that the IC power output is less sensitive to variation in mass flow rate. The ICR and SCR are most sensitive to variation in mass flow rate as indicated in the almost identical values of drops in power output at the highest temperature range, as well as increases. The output variation ranges from -5% to 14% of full power. This drop in power at elevated temperatures and increases in power at lower temperatures was also observed in a study for a VHTR plant, which utilised the SCR configuration and is documented in [16]. With regards to the cycle efficiency figures in Table 5, the IC experienced no drop in efficiency but has a narrower range, which does not exceed 2.3% . The SCR and the ICR showed drops of 2.5% and 1.5% (respectively) in efficiency at elevated temperatures, but showed increases $\sim 7\%$ at lower temperatures. The reason for this is down to the compressor and turbine power. At elevated temperatures, the compressor and turbine power increases but the compressor has a bigger increase. It also indicates that the compressors are sensitive to pressure changes in the cycle due to the lower OPR. Any increases in compressor power will reduce the amount of useful power available including the efficiency of the cycle. In addition, the turbine head increases, which is also affected by the pressure increase. The opposite happens when the inlet temperatures are low.

Load Following Operations to Maintain NPP Power Output

The purpose of this analysis is to compare the time taken for the various cycles to respond to changes in precooler outlet/compressor inlet temperature (T_1) in order to maintain NPP power output to within a tolerance of $\pm 0.1 \text{ MW}_{\text{th}}$. This also includes understanding the effects on other parameters when the control system handle prioritises the NPP power output. The temperature range and the inventory flow rate are unchanged from previous analysis. Figure 10 compares the cumulative times for all three cycles; similar to the previous reactor power analysis.

As the case was when maintaining the reactor power, the IC is the most sensitive to precooler

outlet/compressor inlet temperature changes. The interesting observation from the results is there is a significant increase in the sensitivity levels of the SCR and ICR, when compared to the 'maintaining reactor power' results. With regard to the cumulative results in figure 10 and at a cycle inlet temperature of 50°C , the SCR takes 1 minute 9 seconds from the point of flow regulation to achieve the DP NPP power output; the ICR takes 1 minute 21 seconds and the IC it takes 6 minutes 32 seconds. When the cycle inlet temperature is -30°C , the SCR takes 2 minutes 44 seconds, the ICR takes 5 minutes 22 seconds and the IC takes 13 minutes 12 seconds. When the results for the transient performances at 5°C intervals in Table 6 are analysed and plotted in figure 11, it is clear that the SCR remains stable across the temperature range in terms of time taken to maintain NPP power output, which is the same trend observed when regulating the reactor power. The SCR takes between 13 – 16 seconds except at close to DP to regulate the flow. In stark contrast to the results in Table 2 and figure 9, the ICR does not show the same trend i.e. more time is required at temperatures lower than the DP to regulate the NPP power output. The IC shows the same trend as observed when regulating the reactor power. The reason for the difference in results for the ICR at temperatures lower than DP is due to the combined effect of the intercooler and the recuperator. The recuperator provides the exchange for the waste heat to raise the coolant temperature, thus keeping the exit compressor temperature low. In combination with the intercooler, the output coolant temperature at the inlet of the second compressor is lower in order to reduce the compressor power. The consequence of the lower temperature is that more mass flow is required to maintain the NPP power output.

With regards to the effects of maintaining NPP power output on the reactor power and efficiency, Tables 7 and 8 provide the values respectively. The SCR and ICR exceed the reactor thermal power DP limit by 4% and 2% respectively at elevated temperatures $>30^\circ\text{C}$. The IC reactor power limit is not exceeded for the analysed temperature. The IC cycle is perhaps ideal in locations where increased variation is expected in inlet temperature but with consideration of the regulation times. The slightly lower efficiency of the IC is not a hindering point if the COT is increased beyond 1000°C as documented in [4]. It is recommended to limit load following operations of the SCR and ICR, when maintaining NPP power output to ensure the mechanical integrity of the reactor core is not compromised.

Table 4 – Effect of Maintaining Reactor Thermal Power on NPP Power Output

Temp. (°C)	IC UW (MWel)	ICR UW (MWel)	SC UW (MWel)	IC ΔUW (MWel)	ICR ΔUW (MWel)	SC ΔUW (MWel)	IC %ΔUW (MWel)	ICR %ΔUW (MWel)	SC %ΔUW (MWel)
50	477.0	376.8	271.3	2.6	-11.0	-14.4	1%	-3%	-5%
40	476.3	382.5	278.0	1.9	-5.4	-7.8	0%	-1%	-3%
30	476.0	388.2	284.3	1.6	0.4	-1.4	0%	0%	-1%
28 (DP)	474.4	387.9	285.7	0.0	0.0	0.0	0%	0%	0%
20	477.5	395.2	291.0	3.1	7.3	5.3	1%	2%	2%
10	481.5	404.3	297.8	7.1	16.4	12.1	1%	4%	4%
0	485.5	413.5	304.6	11.1	25.7	18.9	2%	7%	7%
-10	489.8	422.6	311.4	15.4	34.8	25.7	3%	9%	9%
-20	494.0	432.2	318.2	19.6	44.4	32.4	4%	11%	11%
-30	498.5	440.9	324.7	24.1	53.1	38.9	5%	14%	14%

Table 5 – Effect of Maintaining Reactor Thermal Power on NPP Cycle Efficiencies

Temp. (°C)	IC η (%)	ICR η (%)	SC η (%)	IC Δη (%)	ICR Δη (%)	SC Δη (%)
50	45.9	50.7	47.1	0.3	-1.5	-2.5
40	45.8	51.4	48.3	0.2	-0.7	-1.4
30	45.7	52.2	49.4	0.1	0.1	-0.2
28 (DP)	45.6	52.2	49.6	0.0	0.0	0.0
20	45.9	53.1	50.6	0.3	1.0	0.9
10	46.3	54.4	51.8	0.7	2.2	2.1
0	46.7	55.6	52.9	1.1	3.5	3.3
-10	47.1	56.8	54.1	1.5	4.7	4.5
-20	47.5	58.1	55.3	1.9	5.9	5.6
-30	47.9	59.3	56.4	2.3	7.1	6.8

Table 6 – Transient Performance Values per 5°C Increments (NPP Power Output)

Temp. Range (°C)	IC Time (s)	ICR Time (s)	SC Time (s)
45 to 50	99	20	16
40 to 45	93	19	15
35 to 40	88	19	15
30 to 35	83	19	15
28 to 30	29	4	8
25 to 28	53	18	9
20 to 25	84	29	15
15 to 20	81	28	14
10 to 15	77	29	15
5 to 10	74	28	14
0 to 5	70	28	14
-5 to 0	67	28	15
-10 to -5	65	27	14
-15 to -10	62	27	13
-20 to -15	60	27	14
-25 to -20	57	27	14
-30 to -25	55	26	13

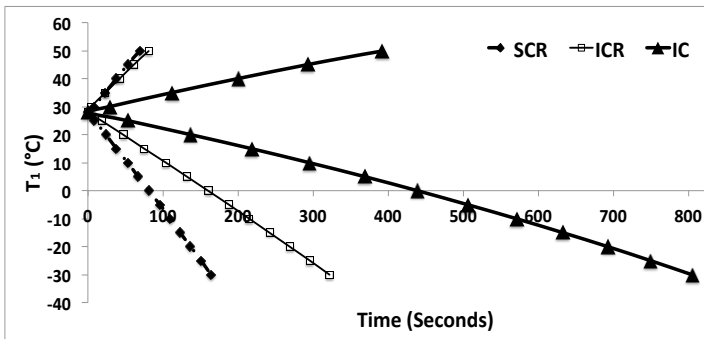

Figure 10 – Cumulative Transient Performance of SCR, ICR & IC when T_1 is Varied (NPP Power Output)

Whereby T_1 temperatures yield an unfavourable reactor power, the control handle should be designed to enable switching of the input variable to the reactor thermal power. Controlling an SCR or ICR NPP at elevated temperatures with the reactor power as the handle, will result in power output deficits if the NPP DP inlet temperature is significantly lower. As per Table 4, the SCR and ICR experienced 14.4% and 11% reduction in power output respectively at a T_1 of 50°C, when the reactor power was regulated. The efficiency penalties are also greater. With regards to the effect on cycle efficiency, the IC does not suffer any drops in cycle efficiency in the temperature range; in fact it shows an increase in efficiency of 0.18% at the elevated temperatures, with modest increases also noted at very low temperatures.

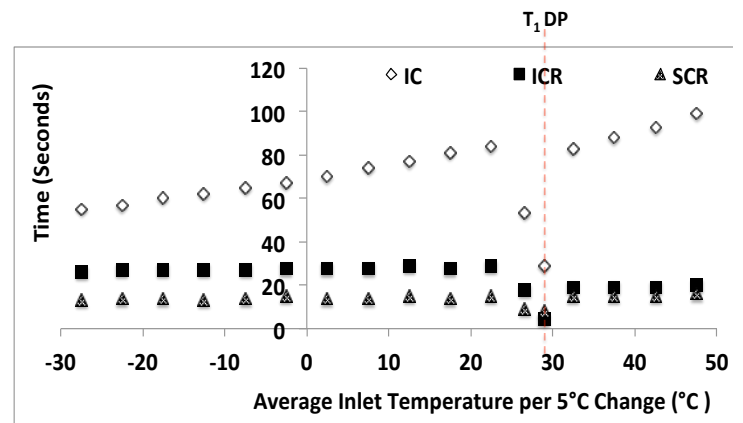

Figure 11 – Transient Performance Values per 5°C Increments (NPP Power Output)

The SCR and the ICR show cycle efficiency drops at temperatures greater than DP but there are significant increases at lower temperatures. The reason for the efficiency trends is due to the effect of the recuperator.

Table 7 – Effect of Maintaining NPP Power Output on Reactor Thermal Power

Temp.	IC	ICR	SC	IC	ICR	SC	IC	ICR	SC
(°C)	Q (MWth)	Q (MWth)	Q (MWth)	ΔQ (MWth)	ΔQ (MWth)	ΔQ (MWth)	% ΔQ (MWth)	% ΔQ (MWth)	% ΔQ (MWth)
50	1036.1	759.2	596.5	-4.0	15.5	20.9	0%	2%	4%
40	1037.1	751.1	586.9	-3.0	7.5	11.4	0%	1%	2%
30	1037.9	743.3	577.7	-2.1	-0.4	2.1	0%	0%	0%
28 (DP)	1040.1	743.7	575.6	0.0	0.0	0.0	0%	0%	0%
20	1035.3	733.5	567.8	-4.8	-10.2	-7.8	0%	-1%	-1%
10	1028.7	721.2	558.4	-11.3	-22.5	-17.1	-1%	-3%	-3%
0	1022.0	709.1	549.4	-18.1	-34.6	-26.2	-2%	-5%	-5%
-10	1015.1	697.1	539.9	-25.0	-46.6	-35.6	-2%	-6%	-6%
-20	1007.8	685.4	531.2	-32.3	-58.3	-44.4	-3%	-8%	-8%
-30	1000.6	673.8	522.4	-39.5	-69.8	-53.2	-4%	-9%	-9%

Table 8 – Effect of Maintaining NPP Power Output on NPP Cycle Efficiencies

Temp.	IC	ICR	SC	IC	ICR	SC
(°C)	η (%)	η (%)	η (%)	$\Delta\eta$ (%)	$\Delta\eta$ (%)	$\Delta\eta$ (%)
50	45.8	51.1	47.9	0.2	-1.1	-1.7
40	45.7	51.6	48.7	0.1	-0.5	-1.0
30	45.7	52.2	49.5	0.1	0.0	-0.2
28 (DP)	45.6	52.2	49.6	0.0	0.0	0.0
20	45.8	52.9	50.3	0.2	0.7	0.7
10	46.1	53.8	51.2	0.5	1.6	1.5
0	46.4	54.7	52.0	0.8	2.6	2.4
-10	46.7	55.6	52.9	1.1	3.5	3.3
-20	47.1	56.6	53.8	1.5	4.4	4.2
-30	47.4	57.6	54.7	1.8	5.4	5.1

As noted in Table 3, the ICR (also the case for the SCR) shows negligible change in pressures and temperatures at the inlet to the reactor when T_1 is increased. With regard to the IC, the pressures and temperatures show substantial increases with T_1 , meaning the reactor thermal power is reduced, thus maintaining the efficiency.

Finally, the conditions that affect the temperature of the coolant at the compressor inlet are the subject of a separate study, which is detailed in [17]. It forms part of the basis for the justification of the temperature variation during the analyses in this study.

Conclusions

In summary, the objective of this study is to demonstrate the load following capabilities of the cycles when using inventory pressure control to maintain NPP power output and reactor thermal power including assessing the effects on cycle efficiency. The results provide a good basis to support preliminary cycle part power performance design, testing, validation and verification activities of Gas Cooled Fast Reactors (GFRs) and Very High Temperature Reactors (VHTRs) for Generation IV NPPs. The main conclusions are:

- Inventory pressure control is proposed to enable steady power regulation based on the following strategies: T_1 variation, constant reactor and power output during load-following operations.

- The IC withdrawal performance is 108% longer than the SCR and 3% longer than the ICR, when withdrawal is performed at DP conditions. It illustrates the volumetric up-scaling that is required for the storage tank of the IC.
- The IC is more susceptible to temperature changes in comparison to the SCR and the ICR, when regulating reactor power. The SCR can regulate the reactor thermal power to within 2 seconds from the point of flow activation to final inventory exchange. The ICR can regulate the flow to within 3 seconds in the majority of cases. The IC requires significant time because T_1 has a positive correlation with increases of temperature and mass flow rate in order to meet the reactor thermal power.
- The IC power output does not drop as a result of maintaining the reactor thermal power. In addition, the variation in power within the analysed temperature range does not exceed 5% and indicates that the IC power output is less sensitive to variation in mass flow rate. The ICR and SCR power output are more sensitive to variation in mass flow rate. The output variation ranges from -5% to 14% of full power. This drop in power at elevated temperatures and increase in power at lower temperatures was also observed in a study for a VHTR plant, which utilised the SCR configuration.
- The IC experienced no drop in efficiency when regulating the reactor power but has a narrower range, which does not exceed 2.3%. The SCR and the ICR showed drops of 2.5% and 1.5% (respectively) in efficiency at elevated temperatures, but showed significant increases of ~7% at lower temperatures.
- The same transient observations were noted when the NPP power is regulated, with the exception of the ICR, which required more time to regulate the power at lower temperatures due to the intercooler.
- The IC is suited to environments where significant variation in cycle inlet temperature is expected because it does not result in additional reactor thermal power when regulating NPP power. However, a compromise is

required on the low Design Point (DP) efficiency of the IC when compared to the SCR and ICR unless the DP COT is increased to increase the efficiency of the IC. This has been investigated in a separate study as part of this research work. The SCR and ICR have better efficiency benefits at lower temperature; however, it is recommended that load following operations to regulate NPP power output is limited to inlet temperatures below DP due to potential increases in reactor power at elevated temperatures.

- Validation is recommended for the tools such as the one developed for this study. This will enable optimisation to improve the applicability and accuracy and will encourage its use thereby reducing costs associated with extensive test activities.

Acknowledgements

The authors wish to thank the Gas Turbine Engineering Group at Cranfield University for providing the necessary support in progressing this research study.

References

- [1] A. Gad-Briggs, P. Pilidis, and T. Nikolaidis, "Analyses of the Control System Strategies and Methodology for Part Power Control of the Simple and Intercooled Recuperated Brayton Helium Gas Turbine Cycles for Generation IV Nuclear Power Plants," *ASME J. Nucl. Eng. Radiat. Sci.*
- [2] F. Carre, P. Yvon, P. Anzieu, N. Chauvin, and J.-Y. Malo, "Update of the French R&D strategy on gas-cooled reactors," *Nucl. Eng. Des.*, vol. 240, no. 10, pp. 2401–2408, Oct. 2010.
- [3] G. Locatelli, M. Mancini, and N. Todeschini, "Generation IV nuclear reactors: Current status and future prospects," *Energy Policy*, vol. 61, pp. 1503–1520, Oct. 2013.
- [4] A. Gad-Briggs, P. Pilidis, and T. Nikolaidis, "A Review of The Turbine Cooling Fraction for Very High Turbine Entry Temperature Helium Gas Turbine Cycles For Generation IV Reactor Power Plants," *ASME J. Nucl. Eng. Radiat. Sci.*, vol. 3, no. 2, 2017.
- [5] K. N. Pradeepkumar, A. Tourlidakis, and P. Pilidis, "Analysis of 115MW, 3-Shaft, Helium Brayton Cycle using Nuclear Heat Source," in *Proceedings of ASME Turbo Expo 2001 Land, Sea & Air. June 4-7, 2001.*, 2001.
- [6] K. N. Pradeepkumar, A. Tourlidakis, and P. Pilidis, "Design and Performance review of PBMR Closed Cycle Gas Turbine Plant in South Africa.," in *International Joint Power Generation Conference. June 4-7 2001.*, 2001.
- [7] K. N. Pradeepkumar, A. Tourlidakis, and P. Pilidis, "Performance Review: PBMR Closed Cycle Gas Turbine Power Plant.," in *Proceedings of Technical Committee Meeting on HTGR - Power Conversion Systems. International Atomic Energy Agency. 14-16 November 2000*, 2001, pp. 99–112.
- [8] K. Bammert and G. Krey, "Dynamic Behaviour and Control of Single-Shaft Closed-Cycle Gas Turbines," *ASME J. Eng. Power*, vol. 93, no. 4, pp. 447–453, 1971.
- [9] M. Kulhanek and V. Dostal, "Supercritical carbon dioxide cycles. Thermodynamic analysis and comparison." Czech Technical University Prague, Prague, Czech Republic, 2007.
- [10] A. Gad-Briggs and P. Pilidis, "Analyses of Simple and Intercooled Recuperated Direct Brayton Helium Gas Turbine Cycles for Generation IV Reactor Power Plants," *J. Nucl. Eng. Radiat. Sci.*, vol. 3, no. 1, 2017.
- [11] A. Gad-Briggs, P. Pilidis, and T. Nikolaidis, "Analyses of a High Pressure Ratio Intercooled Direct Brayton Helium Gas Turbine Cycle for Generation IV Reactor Power Plants," *J. Nucl. Eng. Radiat. Sci.*, vol. 3, no. 1, 2017.
- [12] C. B. Baxi, a. Shenoy, V. I. Kostin, N. G. Kodochigov, a. V. Vasyaev, S. E. Belov, and V. F. Golovko, "Evaluation of alternate power conversion unit designs for the GT-MHR," *Nucl. Eng. Des.*, vol. 238, no. 11, pp. 2995–3001, Nov. 2008.
- [13] A. Gad-Briggs, P. Pilidis, and T. Nikolaidis, "Analyses Of Off-Design Point Performances Of Simple And Intercooled Brayton Helium Recuperated Gas Turbine Cycles For Generation Iv Nuclear Power Plants," in *Proceedings of the 2017 25th International Conference on Nuclear Engineering ICONE25*, 2017, p. To be Published.
- [14] A. Gad-Briggs, P. Pilidis, and T. Nikolaidis, "Analyses Of The Off-Design Point Performance Of A High Pressure Ratio Intercooled Brayton Helium Gas Turbine Cycle For Generation Iv Nuclear Power Plants," in *Proceedings of the 2017 25th International Conference on Nuclear Engineering ICONE25*, 2017, p. To be published.
- [15] H. Sato, X. L. Yan, Y. Tachibana, and K. Kunitomi, "GTHTR300—A nuclear power plant design with 50% generating efficiency," *Nucl. Eng. Des.*, vol. 275, pp. 190–196, Aug. 2014.
- [16] H. Sato, X. Yan, H. Ohashi, Y. Tachibana, and K. Kunitomi, "Control Strategies for VHTR Gas-Turbine System with Dry Cooling," in *Proceedings of the 2012 20th International Conference on Nuclear Engineering ICONE20-Power2012*.
- [17] A. Gad-Briggs, T. Nikolaidis, and P. Pilidis, "Analyses of the Effect of Cycle Inlet Temperature on the Precooler and Plant Efficiency of the Simple and Intercooled Helium Gas Turbine Cycles for Generation IV Nuclear Power Plants," *Appl. Sci.*, vol. 7, no. 4.