



LUND UNIVERSITY

URWARE Wastewater Treatment Plant Models

Jeppsson, Ulf; Baky, A; Hellström, D; Jönsson, H; Kärrman, E

2005

[Link to publication](#)

Citation for published version (APA):

Jeppsson, U., Baky, A., Hellström, D., Jönsson, H., & Kärrman, E. (2005). *URWARE Wastewater Treatment Plant Models*. (Urban Water rapport; Vol. 2005:5). Urban Water, Chalmers University of Technology.
<http://www.iea.lth.se/publications/Reports/LTH-IEA-7223.pdf>

Total number of authors:

5

General rights

Unless other specific re-use rights are stated the following general rights apply:

Copyright and moral rights for the publications made accessible in the public portal are retained by the authors and/or other copyright owners and it is a condition of accessing publications that users recognise and abide by the legal requirements associated with these rights.

- Users may download and print one copy of any publication from the public portal for the purpose of private study or research.
- You may not further distribute the material or use it for any profit-making activity or commercial gain
- You may freely distribute the URL identifying the publication in the public portal

Read more about Creative commons licenses: <https://creativecommons.org/licenses/>

Take down policy

If you believe that this document breaches copyright please contact us providing details, and we will remove access to the work immediately and investigate your claim.

LUND UNIVERSITY

PO Box 117
221 00 Lund
+46 46-222 00 00

The URWARE Wastewater Treatment Plant Models

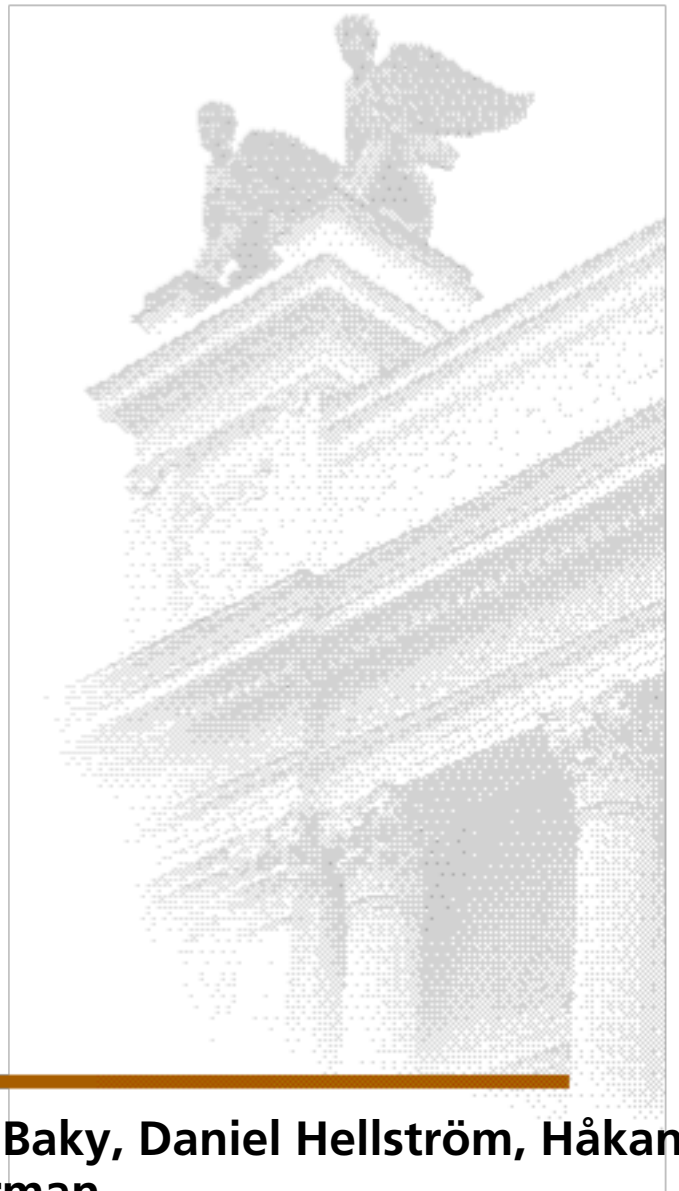

Ulf Jeppsson, Andras Baky, Daniel Hellström, Håkan Jönsson and Erik Kärrman

Dept. of Industrial Electrical Engineering and Automation
Lund University



The URWARE Wastewater Treatment Plant Models

ULF JEPPSSON
ANDRAS BAKY
DANIEL HELLSTRÖM
HÅKAN JÖNSSON
ERIK KÄRRMAN

Urban Water
CHALMERS UNIVERSITY OF TECHNOLOGY
Gothenburg, Sweden, 2005

Report 2005:5

The Mistra Programme
Urban Water

The URWARE Wasterwater Treatment Plant Models

Ulf Jeppsson, Andras Baky,
Daniel Hellström, Håkan Jönsson
and Erik Kärrman

Urban Water Report 2005:5

Contact information:

Dr Ulf Jeppsson
IEA, Lund University
PO Box 118
SE-221 00 Lund
Sweden

Phone: +46 46 222 92 87

Fax: +46 46 14 21 14

Email: ulf.jeppsson@iea.lth.se

Report 2005:5

ISSN 1650-3791

Urban Water

Chalmers University of Technology

412 96 Gothenburg

Sweden

Phone +46 31 772 21 37

www.urbanwater.org

Table of content

Abstract	5
Preface	6
1. Introduction	8
2. Sedimentation	11
2.1 Primary sedimentation	11
2.2 Final sedimentation	28
2.3 Concluding comments.....	29
3. Thickening	30
4. Dewatering	32
5. Sand filtration	43
6. Activated sludge	64
6.1 Adjusting wastewater input to the activated sludge system	65
6.2 Anoxic bioreactor.....	69
6.3 Aerobic bioreactor	78
6.4 Activated sludge settler	86
7. Anaerobic digestion	99
8. Combining the modules into a general WWT plant	116
9. Energy considerations	139
10. Sewer system transformations	143
11. Concluding remarks	150
12. References	152
Appendix	
A. Source code for conversion program load2conc.m	161
B. Source code for conversion program conc2load.m	164
C. Source code for flowcombiner.m.....	167
D. Source code for flowsplitter.m.....	170
E. Source code for hydraulic filter function hyddelay84.c.....	172
F. Source code for activated sludge hydraulic filter function hyddelay91.c.....	174
G. Source code for output validity check program validitycheck.m	176
H. Source code for WWTP initialisation program splnit.m.....	179
I. Source code for primary sedimentation module spPreSModel.m.....	191
J. Source code for final sedimentation module spPostSModel.m.....	199
K. Source code for thickening module spThickModel.m	207
L. Source code for dewatering module spDewModel.m	213
M. Source code for sand filtration module spFiltModel.m	220
N. Source code for activated sludge input adjustment spASInput.m.....	229
O. Source code for anoxic AS module spASAnoxModel.m	232
P. Source code for aerobic AS module spASAerobModel.m	245
Q. Source code for AS 'ideal' settler module spASIdealSModel.m.....	257
R. Source code for anaerobic digestion module spADMModel.m	268
S. Source code for energy adjustment function spEnergyAdjust.m	278
T. Source code for sewer system initialisation program spSewerBioInit.m.....	279
U. Source code for biological sewer system module spSewerBioModel.m.....	281

Abstract

In this document, a large number of mathematical models describing various physical, biological and chemical processes in a wastewater treatment plant are presented. In most cases, the models are fairly simple as they are intended for steady-state simulations based on yearly averages of the influent wastewater characteristics. The combination of models forms a software tool named URWARE (URban WAtER REsearch model), which is a tool for substance flow analysis and energy calculations in wastewater treatment systems. All models are based on the MATLAB/Simulink platform.

The different models can be combined in any fashion thereby creating various system structures that can be analysed and compared. The models keep track of numerous substances related to wastewater, such as organic substances, nutrients and to some extent heavy metals. Within all models the release of environmentally hazardous substances to water, soil and air are calculated. The results can be used as one (of many) information pathways for strategic decision making related to urban water systems.

The individual models are described one by one and their behaviours are exemplified by simulation results. In many cases, comparisons with other available software models are given to validate (or at least make plausible) the results produced by the fairly simple URWARE models. Simulation results based on a combination of models into a complete wastewater treatment plant are also presented. However, details about the underlying theory and hypotheses on which the models are based cannot always be sufficiently described due to space limitations. Moreover, users should always be critical to any results predicted by models and not take them for granted simply because they have been calculated by a computer model. Knowledge about the real processes and comparisons with real data are imperative to evaluate whether the predicted results are reasonable or not. For the interested reader the complete source code to all models is included in an extensive appendix.

A modelling task of this magnitude is never completed. The proposed models can always be further developed, improved and refined. Consequently, the models described in this document only represent the first version of the URWARE software. Many issues remain to be solved and further improvements to be done. However, it is the hope of the authors that the presented models are mature enough to be used, evaluated, modified and improved by other users outside the URWARE task group.

Preface

In an ideal world, process modelling would be a trivial task. Models would be constructed in a simple manner yet in every way reproduce the true process behaviour. Not only would the models be accurate, but they would be concise, easy to use and reveal everything about the internal cause-effect relationships within the process. Each model would be built for a specific task to a prescribed accuracy. Unfortunately, our world is not ideal although the above modelling perspective may serve as an excellent long term goal for everyone dealing with modelling. In the real world it must be realised that a model is always a *simplification of reality*.

The word ‘model’ has a wide spectrum of interpretations, e.g., mental model, linguistic model, visual model, physical model and mathematical model. In this work we will restrict ourselves to mathematical models, that is, models within a mathematical framework where equations of various types are defined to relate inputs, outputs and characteristics of a system.

Primarily, mathematical models are an excellent method of conceptualising knowledge about a process and to convey it to other people. Models are also useful for formulating hypotheses and for incorporating new ideas that can later be verified (or discarded) in reality. An accurate model of a process allows us to predict the process behaviour for different conditions and thereby we can optimize and control a process for a specific purpose of our choice. Finally, models serve as an excellent tool for many educational purposes.

Any given process may have different ‘appropriate’ models. The chosen appropriate model will depend on its objectives. These *a priori* decisions about the model must be made before the model construction can begin. Some of the more relevant objectives concern model *purpose*, *system boundaries*, *time constraints* and *accuracy* (Jeppsson, 1996).

It is the hope of the authors that the models described in this report will be useful for their specific purpose. They represent various processes within a wastewater treatment system and are simple in terms of their limited dynamics (many are only steady-state models as the purpose of the software is to describe yearly averages) but complex in terms of the high number of components being modelled (including energy). By no means can the models be used for detailed design purposes or control applications but they may provide a user with valuable information related to the overall material/substance flows within the system. Some restrictions that apply to the models are related to the fact that wastewater treatment system should be able to interact and be combined with a different set of models from an earlier project (ORWARE – ORganic WAste REsearch model). In ORWARE, models related to other parts of an urban water system have been developed, e.g. waterworks, incineration plants, composting plants, spreading of nutrients on soil, transports. It should also be noted that the model parameters available for a user to modify both within the ORWARE modules and the modules developed in this project (URWARE – URban

Water REsearch model) allows a significant degree of freedom and may cause the models to predict more or less unreasonable results. Consequently, the user should always be critical to any results predicted by the models and not take them for granted simply because they have been calculated by a computer model. Knowledge about the real processes and comparisons with real data are imperative to evaluate whether the predicted results are reasonable or not.

A modelling task of this magnitude is never completed. The proposed models can always be further developed, improved and refined. Consequently, the models described in this document only represent the first version of the URWARE software. Many issues remain to be solved and improvements to be done. However, it is the hope of the authors that the presented models are mature enough to be used, evaluated and improved by new users outside the URWARE task group. Similar to a good wine it is our intent that the models will continue to improve over the years and that they will prove a useful tool for a wide variety of people involved in different fields related to sustainable urban water management.

This document was written by Dr Ulf Jeppsson who also developed the majority of the mathematical models described herein. However, the work was constantly discussed, tested, validated and improved by the entire URWARE task group (Tech. Lic. Andras Baky, Dr Daniel Hellström, Dr Håkan Jönsson and Dr Erik Kärrman) within the MISTRA programme Sustainable Urban Water Management. Important input and valuable comments were also provided by an external reference group consisting of professor emeritus Peter Balmér (formerly Chalmers University of Technology), professor Jes la Cour Jansen (Lund University) and professor Bengt Hultman (Royal Institute of Technology). Their contributions were highly appreciated and are hereby acknowledged.

The project was primarily financed by the Foundation for Strategic Environmental Research (MISTRA) via the Sustainable Urban Water Management research programme (Malmqvist, 1999). The financial support is gratefully acknowledged.

1

Introduction

When it was decided to use the software simulation program ORWARE (e.g. Dalemo, 1999) as a tool within the Sustainable Urban Water Management research programme (Malmqvist, 1999) for material flow analysis several open questions and new needs were identified. Among those needs were:

- Maintain use of ORWARE models for other parts of the urban water system;
- Reduced complexity for some models;
- Modifications to the ORWARE element vector;
- Include exergy, monetary costs and other more abstract variables in the program;
- Make the program easier to use;
- Make the mathematical models more transparent and understandable;
- Enhance the possibility to modify and extend the program in the future;
- Extend the output capabilities of the program;
- Improve the user interface of the program.

Due to the large number of necessary modifications the new tool was renamed URWARE (URban WAter REsearch model), although the model development primarily affects the wastewater treatment part of the system. At the current stage, the URWARE element vector has been extended by 12 new variables (compared to the extended ORWARE version). However, for the initial modelling work a set of 25-30 priority variables are used (varies somewhat from model to model). Another 10 variables should be included in the final version, primarily heavy metals (8 elements) and exergy (heat and chemically based). In terms of complexity, it was very clear that within ORWARE a wide range of complexity for different models existed, in particular some of the mathematical models describing the processes within the wastewater treatment plant (WWTP) were significantly more detailed than the rest of the models. Moreover, since the models were implemented using the graphical model description of Matlab/Simulink (MathWorks, 1997) their readability, transparency and expandability were greatly reduced (mostly due to the 'spaghetti' description and the layer-upon-layer approach

promoted by the graphical model-builder interface). Moreover, all models are based on a steady-state description and no dynamics are included (except for the activated sludge models, which are fully dynamic). This is a consequence of the overall purpose of the program.

It was decided to maintain the modular description of the physical processes within the WWTP (i.e. primary clarifier, activated sludge reactors, secondary clarifier, anaerobic digester, etc.) and allow them to be combined and connected in different ways (as opposed to implementing one large model describing an entire plant and thereby reducing the flexibility of the model). However, each module should be described within a Matlab function (by text-based mathematical equations, i.e. an m-file (MathWorks, 1996)) and its associated parameters (by which the user can change the behaviour of the models) in an accompanying initialisation file. The main behaviour of the models should be based on COD variables rather than different types of organic compounds (e.g. protein, fat and carbohydrate) and modelled as concentrations rather than mass units. This is the common principle in most WWT simulation programs and makes it much easier for the user to validate and get a ‘gut-feeling’ for the realism of the results. As the existing models for other parts of the urban water system in URWARE are currently based on mass, two simple conversion programs (`load2conc.m` and `conc2load.m`) have been created, see Appendices A and B. It should be noted that the vector elements no. 8 (total solids) and no. 22 (water) are always given in mass unit (kg/year). This is an effect of the ORWARE tradition to describe the total mass as the sum of total solids and water, and therefore (based on the assumptions that 1 kg of TS equals 1 dm³ and 1 kg of water equals 1 dm³) provide the means to calculate the total volume of a flow (and thereby the concentrations of other variables). In most cases the TS mass is negligible in comparison to the mass of water but in some cases (e.g. in dewatered sludge) it may comprise 20-30% of the total mass. Therefore this principle is maintained throughout all models. Two more simple modules have been created – `flowcombiner.m` and `flowsplitter.m`, see Appendices C and D. The first one adds two flow streams into one (based on mass load of the different components) and the second one divides a flow stream into two streams by a user-selected split ratio between the two streams. This type of combiners and splitters are always needed when the different process modules are put together to form a larger system.

A number of recirculation flows normally exist within a WWTP (return liquors from sludge treatment, sludge recycling etc.) and can be included in the simulation model. To avoid numerical problems related to the solver and reduce simulation time a special function (`hyddelay84.c`, see Appendix E) has been created and all loops in the system are connected via such a module. It is currently implemented in C (to enhance simulation speed) but could also be an m-file. `Hyddelay84` is simply a low-pass filter with a time constant of 0.001 time units (acting on all 84 URWARE elements), which breaks up the algebraic loops without having any effect on the final outcome of a simulation. Normally a system is simulated 100-300 time units forward in time to guarantee a stable steady-state solution and obviously a

filter function with a time constant of 0.001 has no effect. A special version (`hyddelay91.c`, see Appendix F) is used for loops within the activated sludge part of the model where URWARE is internally using an extended vector version of 91 elements. The reasons for this extension are discussed in the chapters related to the activated sludge modules.

In order to account for the different energy efficiencies for small and large plants a special function is used by which all energy values are multiplied in all models (`spEnergyAdjust.m`, see Appendix S). The shape of this function is defined by the user and simply represents the fact that the energy requirements for a small plant are normally higher than that of a large plant per m^3 of treated wastewater since large electrical drives are normally more efficient than small ones (Kennedy, 1997). The energy adjustment function is further discussed in Chapter 9. The energy adjustment function is based on the total influent flow rate to the wastewater treatment plant. For this reason a special module should be connected to the input of the WWTP in order to store the total influent flow rate in a global variable, which can then be utilised by the energy function. This special module is called `spinfluentflow.m`.

Rudimentary safety checks are included in all models. These checks involve verification that user-defined parameters are within reasonable limits, no input or output variables are negative, mass balances are fulfilled within the model, etc. Warnings or errors are presented to the user if any violations are detected, depending on the severity of the detected problem. If an error is found the simulation pauses and user interaction is needed to continue whereas a warning simply prints to the screen to make the user aware of a potential problem, although the simulation continues. Furthermore, a general validity check program (`validitycheck.m`) has been created and is called by all modules to verify that the relationships between various output variables are within reasonable limits, before the output vectors are passed on to proceeding modules, see Appendix G. This program informs the user what type of problem that have been detected, within which module the problem exists and can easily be extended by new types of checks as the need arise. The use of such programs is useful both during the development phase of models (to detect simple implementation mistakes as well as erroneous modelling principles) and also during future development and extension of the models. It is also a vital tool for an inexperienced user to assist him or her when using URWARE in future work. The software also provides some general information messages at start-up of a simulation (activated/deactivated precipitation, added carbon source, polymer additions, etc.). For user convenience, error messages, warning messages, `validitycheck` module messages and general information messages can be individually disabled by the user.

The general initialisation file (`spInit.m`) defining all parameters related to the WWTP models is given in Appendix H.

In order for a WWTP computer model to produce any reasonable and reliable results it is essential that the influent wastewater is described and characterised properly. The URWARE task group has made extensive in-

vestigations on this topic and in an associated document (Jönsson *et al.*, 2005) the results are discussed. Herein a typical Swedish wastewater is defined based on several different fractions produced by households: urine, faeces, household greywater and solid compostable household waste (sometimes added to the wastewater by use of garbage disposers). However, the characterisation of the wastewater in the above document is based on the situation when the wastewater leaves the buildings and enters the sewer system. As it is a well-established fact that a significant amount of biological and chemical transformations occur already within the sewer system (in particular in large systems with long retention times) the URWARE task group has also developed a simple sewer transformation module to account for hydrolysis, biomass growth and decay in the sewers. Although not a part of the actual WWTP such a model is essential to achieve good results. Therefore a description of this model and its associated initialisation file (`spSewerBioModel.m` in Appendix U and `spSewerBioInit.m` in Appendix T) is also included in this document.

Modelling the type of processes normally found at a WWTP is a somewhat tricky business. At all times various compromises and simplifications (some times also educated guesses) have to be made to maintain transparency and simplicity of the models. This means that a reader of this document who has significant experiences in full-scale WWTP operation and processes may at first find the models difficult to understand and also argue that the models do not represent reality. However, all mathematical models represent a simplification of reality and it is the intended purpose of the models that determines the complexity and level of detail. In the case of URWARE the models are developed for steady-state investigations based on yearly average values, i.e. the level of detail is low (see e.g. Hellström *et al.*, 1999; 2000; Jeppsson and Hellström, 2001). This allows models to be simplified, model variables to be aggregated, kinetic reactions to be neglected, etc. As it is not always pointed out in the following chapters explicitly when model representations do not in detail describe the real processes but represent simplifications, it is important for the reader to always bear this point in mind.

At this stage the user interface and the output capabilities of the software have not been finally decided upon and therefore have not been modified. In the following chapters the principal behaviour and guiding equations and considerations are presented for the different models. The actual source code for each module is given in the appendix.

The development of the URWARE wastewater treatment plant modules is an on-going task and the status and behaviour of the most recent implementation may differ slightly from the description given in this document.

2 Sedimentation

The primary and final settler models describe the settling/clarification process and can be operated in two modes: 0) as an individual settler unit or 1) include the thickener process within the same model. Moreover, chemical precipitation of phosphate by FeCl_3 is also included in both modes (if activated by the user). Should no thickener unit be active (e.g. for some primary clarifiers), this is simply accomplished by changing a model parameter in the initialisation file. The same holds if a user wants to use a dedicated thickener model or dewatering model. The principle of the model and its system borders are shown in Figure 2.1. Note that in mode 0 no input from another module can enter the system between the precipitation tank and the settler (in mode 1 only the defined flow from the thickener is added here). The settler model used to describe the secondary clarifier within the activated sludge part of the WWTP is somewhat different and is discussed later in this document. Numerous publications exist related to modelling of sedimentation processes and the interested reader may for example turn to Ekama *et al.* (1997), Germaey *et al.* (2004), Henze *et al.*, 1995, Jeppsson (1996), Jeppsson and Diehl (1996a; 1996b), Orhon and Artan (1994) and Takács *et al.* (1991) for various aspects of this research field.

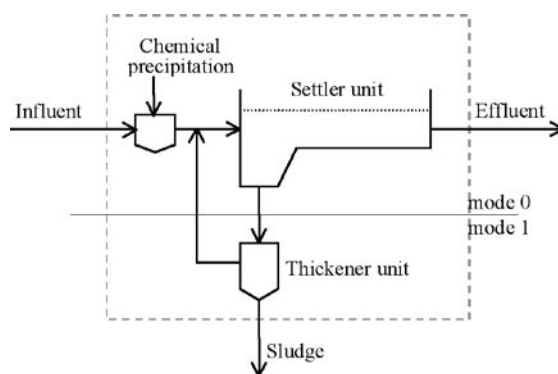

Figure 2.1
General flow scheme
for the sedimentation
models.

2.1 Primary sedimentation

The Matlab code describing the primary sedimentation module is given in Appendix I. The behaviour of the model is influenced by ten user-defined parameters, which are defined in the initialisation file `spInit.m`. These are:

- **spPreSSludgeTSPerc**: defines the total solids content (TS) of the sludge stream (%). Suggested default value is 4% in mode 1 and 2% in mode 0 (Hellström, 2004).
- **spPreSRed**: defines the reduction of total suspended solids (TSS) in the effluent compared to the influent content (%). Suggested value is 80-90% when precipitation is active and 50-70% without precipitation (Balmér, 2004). Note that active precipitation may also motivate a somewhat higher TS content in the sludge stream.
- **spPreSFeCl3In**: defines the concentration of added precipitation chemicals, i.e. kg FeCl₃ per kg added solution (chemical + water). Suggested value 0.2.
- **spPreSPO4Out**: defines the requested effluent concentration of PO₄-P. If the value is higher than the influent concentration the model adjusts the value to equal the influent concentration (i.e. precipitation deactivated) and if it is lower than the influent concentration then the chemical precipitation part of the model is activated. Suggested value when using chemical precipitation together with primary sedimentation is 0.5-2 mg PO₄-P/l.
- **spCODtoVS(1,1)**: conversion factor for calculating volatile solids (VS) from biodegradable COD fractions. Suggested value $1/1.42 \approx 0.704$ (Metcalf & Eddy, 1991).
- **spCODtoVS(2,1)**: conversion factor for calculating volatile solids (VS) from non-biodegradable COD fractions. Suggested value $1/1.9 \approx 0.526$.
- **spPreSMode**: defines the mode the model is operating in (only sedimentation unit (mode 0) or sedimentation and thickening combined (mode 1)).
- **spPreSEnergy(1,1)**: defines the energy required for mixing when precipitation is active. Suggested value 5400 J/m³ of influent flow (= 1.5 Wh/m³).
- **spPreSEnergy(2,1)**: defines the energy required for sludge scrapers. Suggested value 5400 J/m³ of influent flow (= 1.5 Wh/m³).
- **spPreSEnergy(3,1)**: defines the energy required for pumping. Suggested value 180000 J/m³ of pumped flow (= 50 Wh/m³).

To understand the suggested values of **spPreSPO4Out** it must be realised that the variable affected by this (element 79) does not only represent phosphate but also other soluble organic phosphorus forms. Moreover, as no special element is used to represent chemically precipitated P (and thereby allow separating it from organic particulate P) and normally 100% of the precipitated P is assumed to settle, such high values of **spPreSPO4Out** must be used. This is primarily an effect of keeping the models simple rather than describing the actual detailed behaviour of the process. Consequently, no redissolution of precipitated P is modelled and no precipitation within the activated sludge process is modelled. If values for **spPreSPO4Out** of

close to zero was used than the need for available phosphorus for biomass growth in the activated sludge system would not be fulfilled and severe nutrient limitations would occur leading to a strange behaviour of the biological system.

The two CODtoVS conversion factors will for a 'normal' influent wastewater (about 2/3 biodegradable COD and 1/3 inert COD) lead to a ratio between total COD and total VS of 1/1.6. The factors may be adjusted if the user has more detailed information. However, it should be noted that the URWARE WWTP models are based on COD (and to some extent TS and TSS) and VS is secondary variable, which is simply calculated from the COD variables when the outputs from a specific model is defined. The VS variable itself is not used for internal model transformations (the same holds for BOD).

The above ten parameters are gathered into a vector (`spPreSPAR`) and included as an argument when calling the actual primary sedimentation model (`spPreSModel.m`). Consequently, the user has easy access to all model parameters in a specific text file and new parameters can easily be added when the need arise, thus promoting the future flexibility of the program.

Due to the fact that the chemical precipitation is internal within the model (when activated) and the added chemicals not a traditional input variable in the URWARE vector, we first need to make the calculations related to this process. The reason for this is that it will have an effect on the TS, TSS and water content (as well as on Fe and Cl concentrations) as we are forming new particulate material from previously soluble material (dissolved PO_4 into precipitated iron-phosphate), which in turn will influence the general behaviour of the sedimentation process. We are assuming that FeCl_3 is used for precipitation (only simple mass conversions are required if another 3^+ ion is used, i.e. Al^{3+}). The following reactions are assumed:

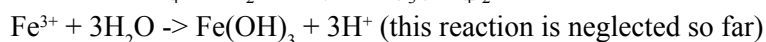
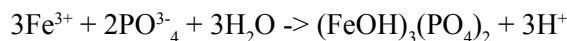

Consequently, an absolute minimum of 1.5 mol of Fe^{3+} is required to remove 1 mol of P (if the last reaction is neglected). This means that 7.86 g FeCl_3 must be added for every g of P removed and that 6.594 g $(\text{FeOH})_3(\text{PO}_4)_2$ is formed for every g of P removed. The phosphate is transformed into particulate P, the amount of TS increases by the amount of added FeCl_3 , the water content increases due to the water phase of the added FeCl_3 solution and the TSS increases by the amount of formed $(\text{FeOH})_3(\text{PO}_4)_2$. The user affects this part of the model by adjusting the parameters `spPreSFeCl3In` and `spPreSPO4Out`. In case `spPreSPO4Out` is set higher or equivalent to the influent PO_4 concentration then no adjustments are made and the influent into the settler is the same as the original input into the module. When chemical precipitation is applied in a primary clarifier the settleability of suspended solids is sometimes improved, in particular if 3^+ ions are used. The effects are considerably smaller if 2^+ ions are added for the precipitation. Therefore the user parameter `spPreSRed` should possibly also be adjusted

to take this into account. Other more detailed changes to the behaviour of the sedimentation process due to chemical precipitation are currently neglected. The transformations are summarised in Table 2.1. It should be noted that before the new values of elements 8, 22, 42, 79 and 80 are calculated, the entire original input vector has been transformed into mass units by the function `conc2load`, whereas `PO4_in` (when calculating the help variable 'removedPO4') represent the concentration. Once the new values of the five variables have been calculated, the function `load2conc` is used to transform the entire vector into concentrations again and thereby taking into account the new values for TS and H₂O caused by the added precipitation chemicals (which will slightly affect all variables in the vector on a concentration basis).

Position. Variable	Relationship	Comment
8. TS	TS_in + addedFeCl3	
22. H2O	H2O_in + addedH2O	extra H2O in FeCl3 solution
42. TSS	TSS_in + createdFeOH3PO42	
79. PO4	spPreSPO4Out*flow_in	PO4 not exactly = spPreSPO4Out
80. P_part	P_part_in + removedPO4	
Help variables		
flow_in = H2O_in + TS_in		mass (= volume)
removedPO4 = (PO4_in - spPreSPO4Out) * flow_in		mass = conc * volume
addedFeCl3 = 7.86 * removedPO4		mass
addedH2O = addedFeCl3 * (1 - spPreSFeCl3In) / spPreSFeCl3In		mass (= volume)
createdFeOH3PO42 = 6.594 * removedPO4		mass

Table 2.1.
Description of the chemical precipitation processes.

Once the internal modifications of the variables in the vector affected by chemical precipitation have been made, it is possible to model the actual sedimentation process (settler alone or with thickener combined). The user defines the requested TS concentration in the sludge stream (% TS, **spPreSSludgeTSPerc**) and also the reduction of suspended solids in the effluent (**spPreSRed**). Based on these two parameters, the fundamental behaviour of the sedimentation process is more or less fixed. We assume that $TS_{dissolved} = TS - TSS$. The fundamental equation is based on a mass balance over the sedimentation process. In terms of TS and water (units kg/y), this means:

$$TS_{in} = TS_{effluent} + TS_{sludge}$$

$$H2O_{in} = H2O_{effluent} + H2O_{sludge}$$

$$totalflow_{in} = totalflow_{effluent} + totalflow_{sludge}$$

where TS_{in} , $H2O_{in}$ and $totalflow_{in}$ (= $TS_{in} + H2O_{in}$) are the adjusted variables after the chemical precipitation effect have been added.

We also know that by definition

$$TS_{sludge} / totalflow_{sludge} = spPreSSludgeTSPerc$$

$$totalflow_{sludge} = TS_{sludge} + H2O_{sludge}$$

$$totalflow_{effluent} = totalflow_{in} - totalflow_{sludge}$$

which means that:

$$TS_sludge / H2O_sludge = \mathbf{spPreSSludgeTSPerc} / (1 - \mathbf{spPreSSludgeTSPerc})$$

by using the following rewriting:

$$TS_sludge / H2O_sludge = TS_sludge / (totalflow_sludge - TS_sludge) =$$

$$TS_sludge / (totalflow_sludge - \mathbf{spPreSSludgeTSPerc} * totalflow_sludge) =$$

$$TS_sludge / (totalflow_sludge * (1 - \mathbf{spPreSSludgeTSPerc})) = \mathbf{spPreSSludgeTSPerc} / (1 - \mathbf{spPreSSludgeTSPerc})$$

However, the TS concentration must also be in accordance with the user-defined request that **spPreSRed** % of the TSS should end up in the sludge stream, i.e.

$$totalflow_in * TSS_in = totalflow_effluent * TSS_effluent + totalflow_sludge * TSS_sludge$$

(mass balance for TSS in unit kg/y * mg/dm³ = mg/y)

$$TSS_sludge = (\mathbf{spPreSRed} * TSS_in * totalflow_in) / totalflow_sludge$$

(based on definition of **spPreSRed**)

$$TSS_effluent = ((1 - \mathbf{spPreSRed}) * TSS_in * totalflow_in) / totalflow_effluent = \text{(i.e. the remaining fraction of TSS, which means } (1 - \mathbf{spPreSRed}), \text{ ends up in the effluent)} \\ = (TSS_in * totalflow_in - TSS_sludge * totalflow_sludge) / (totalflow_in - totalflow_sludge)$$

and consequently all details with regard to the TSS concentrations can be determined if we can find the value of totalflow_sludge. There is only one problem – the totalflow_sludge is a function of TS (and therefore of TSS and TS_dissolved) since totalflow_sludge = H2O_sludge + TS_sludge. In order to avoid having to iterate a solution to the above problem a small simplification is necessary. We simply assume that TS_dissolved is only a function of the water fraction and not the total volume (water + TS). This simplification has very small effects as the water volume is always much higher than the TS volume. We can now solve the above system and uniquely determine totalflow_sludge. The resulting equation is:

$$totalflow_sludge = (\mathbf{spPreSRed} * TSS_in * totalflow_in) / TSS_sludge = (\mathbf{spPreSRed} * TSS_in * totalflow_in) / (10^6 * (\mathbf{spPreSSludgeTSPerc} - TS_in / totalflow_in) - TSS_in)$$

$$\text{note: } \mathbf{spPreSSludgeTSPerc} * 10^6 = TS_sludge \text{ in mg/dm}^3 \text{ (since we assume } 1 \text{ kg} = 1 \text{ dm}^3 \text{) so } TSS_sludge \text{ (mg/dm}^3 \text{) = } 10^6 * (\mathbf{spPreSSludgeTSPerc} - TS_in / totalflow_in) - TSS_in = TS_sludge \text{ (mg/dm}^3 \text{) - } TS_in \text{ (mg/dm}^3 \text{) - } TSS_in \text{ (mg/dm}^3 \text{) = } TS_sludge \text{ (mg/dm}^3 \text{) - } TS_dissolved_in \text{ (mg/dm}^3 \text{)}$$

$$kg/kg = kg/dm^3 = 10^6 \text{ mg/dm}^3$$

where the nominator represents the *mass* of TSS_sludge (in mg TSS/y if the default units are used) and the denominator represents the *concentration* of TSS_sludge (expressed as requested TS_sludge concentration – TS_dissolved concentration assuming that the TS_dissolved concentration is not affected by the increased concentration of TSS in the sludge flow compared to the influent). The problem can also be stated as: **spPreSRed**

allows us to calculate how much mass of TSS should be in the sludge flow and in order to reach the defined TS concentration we must add some water (which then includes TS_dissolved) as well. As the ratio TSS:TS_dissolved will be different in the influent and the sludge flow (since TSS settles due to gravity forces) and the total volume of the sludge flow is water + TS, the difficulty appear. We cannot include the actual volume of the TS_dissolved as such, instead we assume that the TS_dissolved concentration will be same in the influent and the sludge flow, which is not exactly true since a somewhat larger part of the TS volume will now be made up of TSS (and therefore the TS_dissolved concentration slightly lower based on a grab sample). The same problem currently holds for all solubles although it would be possible to compensate for this effect for all solubles except TS_dissolved since the soluble compounds must exist within the volume made up by water + TS – TSS*totalflow in the different streams. However, this type of detailed compensation would serve no practical purpose at this stage. There is a general problem with the mass and volume correlation used in URWARE (e.g. 1 kg TS = 1 dm³). It can be discussed how correct it is to state that dissolved substances add to the volume according to their weight. For example, adding 200 g NaCl to 1000 g water will replace about 80 g of water (at 20°C) once the NaCl has dissolved, if the volume should be the same before and after the addition of NaCl, i.e. the relationship is not 1:1 of volume and weight. However, at this level of detail for the URWARE models such effects are neglected.

Based on the above we can now formulate the expressions for calculating the different flow streams leaving the sedimentation process. This is shown in Table 2.2. Note that all in-variables have already been adjusted for the effects caused by the chemical precipitation.

Help variable	Relationship	Comment
totalflow_in	= H2O_in + TS_in	Adjusted for FeCl ₃ addition
totalflow_sludge	$= \frac{(TSS_in * totalflow_in * spPreSRed)}{(10e6 * (spPreSSludgeTSPerc - TS_in/totalflow_in) - TSS_in)}$	TSS_in as concentration (mg/l) whereas TS_in and totalflow_in as mass flows (kg/y)
H2Oflow_sludge	$= totalflow_sludge * (1 - spPreSSludgeTSPerc)$	
TSflow_sludge	= totalflow_sludge – H2Oflow_sludge	
totalflow_effluent	= totalflow_in – totalflow_sludge	
TSflow_effluent	= TS_in – TSflow_sludge	
H2Oflow_effluent	= totalflow_effluent – TSflow_effluent	

Table 2.2
Calculating the different flows (water phase and total).

Once these fundamental expressions have been defined we can easily calculate the behaviour for the other priority variables in the URWARE vector. At this stage the behaviour is simply a matter of whether a variable is dissolved (in which case the influent concentration is equivalent to the output concentration) or particulate (in which case the variable will behave in the same way as the TSS variable). However, the particulate phosphorus formed by precipitation is assumed to settle completely and is included in the sludge stream whereas the particulate organic P already present in the

influent wastewater to the plant settles according to TSS. Although it may be more realistic to also assume a removal efficiency of precipitated P equal to that of TSS, this is again an effect of simplified modelling. As no separation of organic particulate P and precipitated P is used in URWARE (they are lumped into one variable) this would mean that the precipitated P would be highly active in the biological system in terms of hydrolysis and other processes that will affect the particulate organic P. In such a case the processes of redissolution of fixed P and simultaneous P precipitation would also have to be included to allow for a realistic behaviour. Consequently, to avoid such level of model complexity we instead assume totally ideal settling of precipitated P. In total (see earlier in this section) this means that more soluble P (element 79) and less particulate P (element 80) enters the biological system when compared to full-scale practical experience. However, the total amount of P (element 30) in the primary settler effluent may certainly represent a realistic value. A similar problem exists for particulate sulphur as both organically bound particulate S and mineralised S are lumped into one variable (element 46). However, particulate S is assumed to settle according to the TSS. VS is calculated based on the defined conversion parameters whereas BOD in the output streams is proportional to the BOD:COD_biodegradable ratio in the influent and the same ratio is assumed in the two output streams. This is a reasonable assumption as biological activity in the settler is not assumed to occur. In Table 2.3 the calculations are shown for all variables in the effluent flow stream. Note that the 'in'-variables used in Table 2.3 represent the output variables from the initial precipitation process described in Table 2.1, i.e. not the inputs to the overall system as defined in Figure 2.1.

When all the variables in the effluent vector have been calculated, the easiest (and safest) way to determine the variables in the sludge vector is to use the overall mass balance. This means that for each variable related to the sludge stream the following calculation is carried out:

$$\text{sludge variable} = \frac{(\text{influent variable} * \text{totalflow_in} - \text{effluent variable} * \text{totalflow_effluent})}{\text{totalflow_sludge}}$$

Finally, five extra variables are given in the output vector for further analysis by the user:

- addedFeCl3;
- total energy use;
- energy for mixing of precipitation chemicals;
- energy for sludge scrapers;
- energy for pumping.

The calculation of addedFeCl3 was described already in Table 2.1.

Position. variable name	Relationship	Comment
6. BOD	$= \text{in}(6) * (\text{out}(75) + \text{out}(77)) / (\text{in}(75) + \text{in}(77))$	Calculated once effluent variables 75 and 77 are known
7. Volatile solids (VS)	$= \text{spCODtoVS}(1,1) * (\text{out}(75) + \text{out}(77)) + \text{spCODtoVS}(2,1) * (\text{out}(76) + \text{out}(78))$	Calculated once effluent variables 75, 76, 77 and 78 are known
8. Total solids (TS)	$= \text{TSflow_effluent}$	See Table 2.2, mass unit
22. Water	$= \text{H2Oflow_effluent}$	See Table 2.2, mass unit
23. Total nitrogen (N-tot)	$= \text{out}(24) + \text{out}(26) + \text{out}(44) + \text{out}(81)$	Calculated once effluent variables 24, 26, 44 and 81 are known
24. Ammonia/ammonium	$= \text{in}(24)$	$\text{NH4_out} = \text{NH4_in}$
26. Nitrate/nitrite	$= \text{in}(26)$	$\text{NO3_out} = \text{NO3_in}$
28. Total sulphur (S-tot)	$= \text{out}(29) + \text{out}(46)$	Calculated once effluent variables 29 and 46 are known
29. Sulphate	$= \text{in}(29)$	$\text{SO4_out} = \text{SO4_in}$
30. Total phosphorus (P-tot)	$= \text{out}(79) + \text{out}(80)$	Calculated once effluent variables 79 and 80 are known
32. Total potassium (K-tot)	$= (\text{in}(32) - \text{in}(49)) + \text{in}(49) * \text{totalflow_in} * (1 - \text{spPreSRed}) / \text{totalflow_effluent}$	$\text{K_out} = \text{K_in_dissolved} + \text{organically bound K equivalent to TSS}$
42. Suspended solids (TSS)	$= \text{in}(42) * \text{totalflow_in} * (1 - \text{spPreSRed}) / \text{totalflow_effluent}$	
43. Total COD	$= (\text{in}(43) * \text{totalflow_in} - (\text{in}(75) + \text{in}(76)) * \text{totalflow_sludge} - \text{spPreSRed} * (\text{in}(77) + \text{in}(78)) * \text{totalflow_in}) / \text{totalflow_effluent}$	Equivalent to $\text{out}(75) + \text{out}(76) + \text{out}(77) + \text{out}(78)$
44. Soluble organic nitrogen	$= \text{in}(44)$	$\text{Norg,sol_out} = \text{Norg,sol_in}$
46. Particulate sulphur	$= \text{in}(46) * \text{totalflow_in} * (1 - \text{spPreSRed}) / \text{totalflow_effluent}$	Equivalent to TSS
48. Sulfide (HS-S)	$= \text{in}(48)$	
49. Organically bound potassium	$= \text{in}(49) * \text{totalflow_in} * (1 - \text{spPreSRed}) / \text{totalflow_effluent}$	Equivalent to TSS
75. COD, soluble&biodreg	$= \text{in}(75)$	$\text{CODsol,bio_out} = \text{CODsol,bio_in}$
76. COD, soluble&inert	$= \text{in}(76)$	$\text{CODsol,inert_out} = \text{CODsol,inert_in}$
77. COD, part&biodreg	$= \text{in}(77) * \text{totalflow_in} * (1 - \text{spPreSRed}) / \text{totalflow_effluent}$	Equivalent to TSS
78. COD, part&inert	$= \text{in}(78) * \text{totalflow_in} * (1 - \text{spPreSRed}) / \text{totalflow_effluent}$	Equivalent to TSS
79. Phosphate	$= \text{in}(79)$	$\text{PO4_out} = \text{PO4_in}$
80. Phosphorus, particulate	$= (\text{in}(80) * \text{totalflow_in} - \text{removedPO4}) * (1 - \text{spPreSRed}) / \text{totalflow_effluent}$	Precipitated P settles 100% and the remaining P _{part} is handled equivalent to TSS
81. Nitrogen, org&particulate	$= \text{in}(81) * \text{totalflow_in} * (1 - \text{spPreSRed}) / \text{totalflow_effluent}$	Equivalent to TSS
82. Temperature	$= \text{in}(82)$	

Table 2.3.
Calculating the variables in the effluent stream.

The energy usage is divided into three sub-categories and based on several assumptions (see also Chapter 9). Energy use is normally calculated in relation to flow so that the energy use automatically adjusts to plants of different sizes and different layouts of the same plant. If chemical precipitation is active then an energy use related to this process is included (e.g. for mixing), which is defined by the parameter **spPreSEnergy(1,1)** and the suggested value is 1.5 Wh per m³ of influent flow to the unit (5400 J/m³). When the model is operated in mode 0 then the energy requirements of the sedimentation unit is divided into two categories: energy for pumping and energy for sludge scrapers. The energy for sludge scrapers is defined by the parameter **spPreSEnergy(2,1)** and the suggested value is 1.5 Wh per m³ of influent flow to the unit (5400 J/m³) and energy for pumping is defined

by the parameter **spPreSEnergy(3,1)** and the suggested value is 50 Wh/m³ of the sludge flow (180000 J/m³). Only the sludge stream is assumed to require pumping whereas the effluent water is self-flowing as a result of a good hydraulic design of the whole plant. If the model is operated in mode 1 then it is assumed by default that the underflow from the sedimentation unit into the thickener is 2% of influent flow, which means that energy for sludge scrapers is increased by 2% (sludge scrapers in the thickener) and that both the effluent flow and underflow from the thickener must be pumped (either back into the sedimentation unit or onwards to the next process). Consequently, also the pumping energy in mode 1 is increased by a factor of **spPreSEnergy(3,1)** times (2% of the influent flow plus 2% of the influent flow minus the thickener sludge flow), i.e. the 2% pumped from the settler into the thickener and the effluent flow from the thickener, which is pumped back to the settler. Note that in mode 1 the sludge concentration in the underflow from the sedimentation unit is not defined (only the underflow concentration from the thickener) but with an influent flow rate of 200 l/(person&day) and a removal of about 80 g SS/(person&day) the assumed flow rate of 2% (i.e. 4 l/(person&day)) would yield a sludge concentration in the settler underflow of 20 g/l (= 2%), which is identical to the default value of 2% (**spPreSSludgeTSPerc**) suggested for the model in mode 0. The three different energy categories are then added together and given as an output variable from the model. The details are given in the pseudo-code below.

```

if chemical precipitation active then
    sludgemixenergy = spPreSEnergy(1,1)*totalflow_in/1000; %J/year
else
    sludgemixenergy = 0;
end
in both mode 0 and 1 the following is calculated
pumpingenergy = spPreSEnergy(3,1)*totalflow_sludge/1000; %J/year
sludgeremenergy = spPreSEnergy(2,1)*totalflow_in/1000; %J/year
if operated in mode 0
    energy = sludgemixenergy + pumpingenergy + sludgeremenergy; %J/year
else if operated in mode 1
    pumpingenergy = pumpingenergy + spPreSEnergy(3,1)*(0.04*totalflow_in -
        totalflow_sludge)/1000; %assume 2% flow from settler to thickener
    energy = sludgemixenergy + pumpingenergy + 1.02*sludgeremenergy; %J/year

```

In order to account for the different energy efficiencies for small and large plants a special function is used by which all energy values are multiplied in all models. The shape of this function is defined by the user and simply represents the fact that the energy requirements for a small plant is normally higher than that of a large plant per m³ of treated wastewater since large electrical drives are normally more efficient than small ones. The energy adjustment function is further discussed in Chapter 9. The values suggested for the three **spPreSEnergy** parameters represent the situation at a large and energy-efficient WWTP.

To demonstrate the general behaviour of the model, two cases are pre-

sented below. The first one represents a case when no chemical precipitation is used and the second case demonstrates the behaviour with active precipitation. In both cases the contents of the influent wastewater is the same. Note that the energy adjustment function is not activated in the cases shown below.

Case 2.1: Presedimentation + thickener without chemical precipitation

Model parameters: **spPreSSludgeTSPerc** = 0.04 (4%)
spPreSRed = 0.6 (60%)
spPreSFeCl3In = 0.2 (g FeCl₃/g solution)
spPreSPO4Out = 10 mg P/l (i.e. > PO₄-P in, no precipitation)
spCODtoVS(1,1) = 1/1.42 (g VS/g COD_{biodeg})
spCODtoVS(2,1) = 1/1.9 (g VS/g COD_{inert})
spPreSMode = 1
spPreSEnergy(1,1) = 5400 J/m³
spPreSEnergy(2,1) = 5400 J/m³
spPreSEnergy(3,1) = 180000 J/m³

Influent wastewater

BOD7 = 334.3933 g/m³; 554800 kg/y; 76 g/cap.day
COD total = 731.5313 g/m³; 1213701.2 kg/y; 166.2604 g/cap.day
COD biosol = 105.2249 g/m³; 174581.2 kg/y; 23.9152 g/cap.day
COD insol = 30.0002 g/m³; 49774 kg/y; 6.8184 g/cap.day
COD biopart = 396.3091 g/m³; 657526 kg/y; 90.0721 g/cap.day
COD inpart = 199.9971 g/m³; 331820 kg/y; 45.4548 g/cap.day
Sum of COD-fractions = 1213701.2 kg/y

Volatile solids (VS) = 426.0983 g/m³; 706950 kg/y; 96.8425 g/cap.day
Suspended solids (TSS) = 419.9342 g/m³; 696723 kg/y; 95.4415 g/cap.day
Dissolved solids (TS-TSS) = 765.0284 g/m³; 1269277 kg/y; 173.8736 g/cap.day
Fixed solids (TS-VS) = 758.8643 g/m³; 1259050 kg/y; 172.4726 g/cap.day
Total solids (TS) = 1184.9626 g/m³; 1966000 kg/y; 269.3151 g/cap.day
H₂O = 1657158100 kg/y; 227.008 kg/cap.day
Total volume = 1659124.1 m³/y; 4545.5455 m³/day
VS content = 0.04261 %
TSS content = 0.041993 %
TS content = 0.1185 %
Total nitrogen = 107.1098 g/m³; 177708.476 kg/y; 24.3436 g/cap.day
N-NH₃ & N-NH₄ = 52.0033 g/m³; 86280 kg/y; 11.8192 g/cap.day
N-NO₃ = 0.072327 g/m³; 120 kg/y; 0.016438 g/cap.day
N-N₂O = 0 g/m³; 0 kg/y; 0 g/cap.day
N-org,part = 29.8151 g/m³; 49467 kg/y; 6.7763 g/cap.day
N-org,sol = 25.219 g/m³; 41841.476 kg/y; 5.7317 g/cap.day
Sum of N-fractions = 177708.476 kg/y
N content per TSS (N-org,part/TSS) = 7.1 %
N content per TS (Total N/TS) = 9.0391 %

Total sulphur = 5.3088 g/m³; 8808 kg/y; 1.2066 g/cap.day
SO₄-S = 2.6544 g/m³; 4404 kg/y; 0.60329 g/cap.day
S particulate = 1.3272 g/m³; 2202 kg/y; 0.30164 g/cap.day
Sulfide HS-S = 1.3272 g/m³; 2202 kg/y; 0.30164 g/cap.day

The URWARE Wastewater Treatment Plant Models

Sum of S-fractions = 8808 kg/y
S content per TSS (S particulate/TSS) = 0.31605 %
S content per TS (Total S/TS) = 0.44802 %

Total phosphorus = 10.9938 g/m³; 18240 kg/y; 2.4986 g/cap.day
PO₄-P = 5.8163 g/m³; 9650 kg/y; 1.3219 g/cap.day
P particulate = 5.1774 g/m³; 8590 kg/y; 1.1767 g/cap.day
Sum of P-fractions = 18240 kg/y
P content per TSS (P particulate/TSS) = 1.2329 %
P content per TS (Total P/TS) = 0.92777 %

Total potassium = 19.7996 g/m³; 32850 kg/y; 4.5 g/cap.day
Dissolved potassium = 18.8096 g/m³; 31207.5 kg/y; 4.275 g/cap.day
Organically bound potassium = 0.98998 g/m³; 1642.5 kg/y; 0.225 g/cap.day
K content per TSS (Organically bound K/TSS) = 0.23575 %
K content per TS (Total K/TS) = 1.6709 %
Temperature in water = 20 degC

Effluent wastewater

BOD₇ = 176.5351 g/m³; 291012.7635 kg/y; 39.8648 g/cap.day
COD total = 375.2892 g/m³; 618652.8278 kg/y; 84.747 g/cap.day
COD biosol = 105.2249 g/m³; 173460.0682 kg/y; 23.7617 g/cap.day
COD insol = 30.0002 g/m³; 49454.3596 kg/y; 6.7746 g/cap.day
COD biopart = 159.5482 g/m³; 263010.4 kg/y; 36.0288 g/cap.day
COD inpart = 80.5159 g/m³; 132728 kg/y; 18.1819 g/cap.day
Sum of COD-fractions = 618652.8278 kg/y

Volatile solids (VS) = 244.6263 g/m³; 403259.0216 kg/y; 55.241 g/cap.day
Suspended solids (TSS) = 169.0594 g/m³; 278689.2 kg/y; 38.1766 g/cap.day
Dissolved solids (TS-TSS) = 765.0284 g/m³; 1261125.9118 kg/y; 172.757 g/cap.day
Fixed solids (TS-VS) = 689.4614 g/m³; 1136556.0902 kg/y; 155.6926 g/cap.day
Total solids (TS) = 934.0877 g/m³; 1539815.1118 kg/y; 210.9336 g/cap.day
H₂O = 1646929662.6827 kg/y; 225.6068 kg/cap.day
Total volume = 1648469.4778 m³/y; 4516.3547 m³/day
VS content = 0.024463 %
TSS content = 0.016906 %
TS content = 0.093409 %

Total nitrogen = 89.2978 g/m³; 147204.7303 kg/y; 20.165 g/cap.day
N-NH₃ & N-NH₄ = 52.0033 g/m³; 85725.924 kg/y; 11.7433 g/cap.day
N-NO₃ = 0.072327 g/m³; 119.2294 kg/y; 0.016333 g/cap.day
N-N₂O = 0 g/m³; 0 kg/y; 0 g/cap.day
N-org,part = 12.0031 g/m³; 19786.8 kg/y; 2.7105 g/cap.day
N-org,sol = 25.219 g/m³; 41572.7769 kg/y; 5.6949 g/cap.day
Sum of N-fractions = 147204.7303 kg/y
N content per TSS (N-org,part/TSS) = 7.1 %
N content per TS (Total N/TS) = 9.5599 %

Total sulphur = 4.5159 g/m³; 7444.3774 kg/y; 1.0198 g/cap.day
SO₄-S = 2.6544 g/m³; 4375.7182 kg/y; 0.59941 g/cap.day
S particulate = 0.53431 g/m³; 880.8 kg/y; 0.12066 g/cap.day
Sulfide HS-S = 1.3272 g/m³; 2187.8591 kg/y; 0.29971 g/cap.day
Sum of S-fractions = 7444.3774 kg/y
S content per TSS (S particulate/TSS) = 0.31605 %
S content per TS (Total S/TS) = 0.48346 %

Total phosphorus = 7.9007 g/m³; 13024.0293 kg/y; 1.7841 g/cap.day
PO₄-P = 5.8163 g/m³; 9588.0293 kg/y; 1.3134 g/cap.day

The URWARE Wastewater Treatment Plant Models

P particulate = 2.0844 g/m³; 3436 kg/y; 0.47068 g/cap.day
Sum of P-fractions = 13024.0293 kg/y
P content per TSS (P particulate/TSS) = 1.2329 %
P content per TS (Total P/TS) = 0.84582 %

Total potassium = 19.2082 g/m³; 31664.0906 kg/y; 4.3375 g/cap.day
Dissolved potassium = 18.8096 g/m³; 31007.0906 kg/y; 4.2475 g/cap.day
Organically bound potassium = 0.39855 g/m³; 657 kg/y; 0.09 g/cap.day
K content per TSS (Organically bound K/TSS) = 0.23575 %
K content per TS (Total K/TS) = 2.0564 %
Temperature in water = 20 degC

Sludge stream

BOD7 = 24758.0094 g/m³; 263787.2365 kg/y; 36.1352 g/cap.day
COD total = 55848.8476 g/m³; 595048.3722 kg/y; 81.5135 g/cap.day
COD biosol = 105.2249 g/m³; 1121.1318 kg/y; 0.15358 g/cap.day
COD insol = 30.0002 g/m³; 319.6404 kg/y; 0.043786 g/cap.day
COD biopart = 37027.6479 g/m³; 394515.6 kg/y; 54.0432 g/cap.day
COD inpart = 18685.9746 g/m³; 199092 kg/y; 27.2729 g/cap.day
Sum of COD-fractions = 595048.3722 kg/y

Volatile solids (VS) = 28503.2142 g/m³; 303690.9784 kg/y; 41.6015 g/cap.day
Suspended solids (TSS) = 39234.9716 g/m³; 418033.8 kg/y; 57.2649 g/cap.day
Dissolved solids (TS-TSS) = 765.0284 g/m³; 8151.0882 kg/y; 1.1166 g/cap.day
Fixed solids (TS-VS) = 11496.7858 g/m³; 122493.9098 kg/y; 16.78 g/cap.day
Total solids (TS) = 40000 g/m³; 426184.8882 kg/y; 58.3815 g/cap.day
H2O = 10228437.3173 kg/y; 1.4012 kg/cap.day
Total volume = 10654.6222 m³/y; 29.1907 m³/day
VS content = 2.8503 %
TSS content = 3.9235 %
TS content = 4 %

Total nitrogen = 2862.9589 g/m³; 30503.7457 kg/y; 4.1786 g/cap.day
N-NH₃ & N-NH₄ = 52.0033 g/m³; 554.076 kg/y; 0.075901 g/cap.day
N-NO₃ = 0.072327 g/m³; 0.77062 kg/y; 0.00010556 g/cap.day
N-N₂O = 0 g/m³; 0 kg/y; 0 g/cap.day
N-org,part = 2785.6642 g/m³; 29680.2 kg/y; 4.0658 g/cap.day
N-org,sol = 25.219 g/m³; 268.6991 kg/y; 0.036808 g/cap.day
Sum of N-fractions = 30503.7457 kg/y
N content per TSS (N-org,part/TSS) = 7.1 %
N content per TS (Total N/TS) = 7.1574 %

Total sulphur = 127.9841 g/m³; 1363.6226 kg/y; 0.1868 g/cap.day
SO₄-S = 2.6544 g/m³; 28.2818 kg/y; 0.0038742 g/cap.day
S particulate = 124.0025 g/m³; 1321.2 kg/y; 0.18099 g/cap.day
Sulfide HS-S = 1.3272 g/m³; 14.1409 kg/y; 0.0019371 g/cap.day
Sum of S-fractions = 1363.6226 kg/y
S content per TSS (S particulate/TSS) = 0.31605 %
S content per TS (Total S/TS) = 0.31996 %

Total phosphorus = 489.55 g/m³; 5215.9707 kg/y; 0.71452 g/cap.day
PO₄-P = 5.8163 g/m³; 61.9707 kg/y; 0.0084891 g/cap.day
P particulate = 483.7337 g/m³; 5154 kg/y; 0.70603 g/cap.day
Sum of P-fractions = 5215.9707 kg/y
P content per TSS (P particulate/TSS) = 1.2329 %
P content per TS (Total P/TS) = 1.2239 %

Total potassium = 111.3047 g/m³; 1185.9094 kg/y; 0.16245 g/cap.day

Dissolved potassium = 18.8096 g/m³; 200.4094 kg/y; 0.027453 g/cap.day
 Organically bound potassium = 92.4951 g/m³; 985.5 kg/y; 0.135 g/cap.day
 K content per TSS (Organically bound K/TSS) = 0.23575 %
 K content per TS (Total K/TS) = 0.27826 %
 Temperature in water = 20 degC

Extra output variables

Added FeCl₃ = 0 kg/y; 0 g/cap.day
 Amount of total energy used = 21.084 GJ/y = 5856.7 kWh/y; 0.802 Wh/cap.day
 Amount of energy used for mixing = 0 GJ/y = 0 kWh/y; 0 Wh/cap.day
 Amount of energy used for sludge scrapers = 9.138 GJ/y = 2538.5 kWh/y; 0.348 Wh/cap.day
 Amount of energy used for pumping = 11.946 GJ/y = 3318.2 kWh/y; 0.455 Wh/cap.day

If the same degree of sludge concentration could be achieved in mode 0 (i.e. only a sedimentation unit but no extra thickener then the following holds:

Amount of total energy used = 10.877 GJ/y = 3021.4 kWh/y; 0.414 Wh/cap.day
 Amount of energy used for mixing = 0 GJ/y = 0 kWh/y; 0 Wh/cap.day
 Amount of energy used for sludge scrapers = 8.959 GJ/y = 2488.7 kWh/y; 0.341 Wh/cap.day
 Amount of energy used for pumping = 1.918 GJ/y = 532.7 kWh/y; 0.073 Wh/cap.day

The difference is primarily related to internal pumping energy of the assumed 2% of the influent flow from the settler to the thickener and then back to the settler.

Case 2.2: Presedimentation + thickener with chemical precipitation

Model parameters: **spPreSSludgeTSPerc** = 0.04 (4%)
spPreSRed = 0.9 (90%)
spPreSFeCl3In = 0.2 (g FeCl₃/g solution)
spPreSPO4Out = 0.75 mg P/l (i.e. < PO₄-P in, precipitation)
spCODtoVS(1,1) = 1/1.42 (g VS/g COD_{biodeg})
spCODtoVS(2,1) = 1/1.9 (g VS/g COD_{inert})
spPreSMode = 1
spPreSEnergy(1,1) = 5400 J/m³
spPreSEnergy(2,1) = 5400 J/m³
spPreSEnergy(3,1) = 180000 J/m³

Influent wastewater

BOD₇ = 334.3933 g/m³; 554800 kg/y; 76 g/cap.day
 COD total = 731.5313 g/m³; 1213701.2 kg/y; 166.2604 g/cap.day
 COD biosol = 105.2249 g/m³; 174581.2 kg/y; 23.9152 g/cap.day
 COD insol = 30.0002 g/m³; 49774 kg/y; 6.8184 g/cap.day
 COD biopart = 396.3091 g/m³; 657526 kg/y; 90.0721 g/cap.day
 COD inpart = 199.9971 g/m³; 331820 kg/y; 45.4548 g/cap.day
 Sum of COD-fractions = 1213701.2 kg/y

Volatile solids (VS) = 426.0983 g/m³; 706950 kg/y; 96.8425 g/cap.day

The URWARE Wastewater Treatment Plant Models

Suspended solids (TSS) = 419.9342 g/m³; 696723 kg/y; 95.4415 g/cap.day
Dissolved solids (TS-TSS) = 765.0284 g/m³; 1269277 kg/y; 173.8736 g/cap.day
Fixed solids (TS-VS) = 758.8643 g/m³; 1259050 kg/y; 172.4726 g/cap.day
Total solids (TS) = 1184.9626 g/m³; 1966000 kg/y; 269.3151 g/cap.day
H₂O = 1657158100 kg/y; 227.008 kg/cap.day
Total volume = 1659124.1 m³/y; 4545.5455 m³/day
VS content = 0.04261 %
TSS content = 0.041993 %
TS content = 0.1185 %

Total nitrogen = 107.1098 g/m³; 177708.476 kg/y; 24.3436 g/cap.day
N-NH₃ & N-NH₄ = 52.0033 g/m³; 86280 kg/y; 11.8192 g/cap.day
N-NO₃ = 0.072327 g/m³; 120 kg/y; 0.016438 g/cap.day
N-N₂O = 0 g/m³; 0 kg/y; 0 g/cap.day
N-org,part = 29.8151 g/m³; 49467 kg/y; 6.7763 g/cap.day
N-org,sol = 25.219 g/m³; 41841.476 kg/y; 5.7317 g/cap.day
Sum of N-fractions = 177708.476 kg/y
N content per TSS (N-org,part/TSS) = 7.1 %
N content per TS (Total N/TS) = 9.0391 %

Total sulphur = 5.3088 g/m³; 8808 kg/y; 1.2066 g/cap.day
SO₄-S = 2.6544 g/m³; 4404 kg/y; 0.60329 g/cap.day
S particulate = 1.3272 g/m³; 2202 kg/y; 0.30164 g/cap.day
Sulfide HS-S = 1.3272 g/m³; 2202 kg/y; 0.30164 g/cap.day
Sum of S-fractions = 8808 kg/y
S content per TSS (S particulate/TSS) = 0.31605 %
S content per TS (Total S/TS) = 0.44802 %

Total phosphorus = 10.9938 g/m³; 18240 kg/y; 2.4986 g/cap.day
PO₄-P = 5.8163 g/m³; 9650 kg/y; 1.3219 g/cap.day
P particulate = 5.1774 g/m³; 8590 kg/y; 1.1767 g/cap.day
Sum of P-fractions = 18240 kg/y
P content per TSS (P particulate/TSS) = 1.2329 %
P content per TS (Total P/TS) = 0.92777 %

Total potassium = 19.7996 g/m³; 32850 kg/y; 4.5 g/cap.day
Dissolved potassium = 18.8096 g/m³; 31207.5 kg/y; 4.275 g/cap.day
Organically bound potassium = 0.98998 g/m³; 1642.5 kg/y; 0.225 g/cap.day
K content per TSS (Organically bound K/TSS) = 0.23575 %
K content per TS (Total K/TS) = 1.6709 %
Temperature in water = 20 degC

Effluent wastewater

BOD₇ = 96.8397 g/m³; 159029.9929 kg/y; 21.7849 g/cap.day
COD total = 195.4434 g/m³; 320956.8057 kg/y; 43.9667 g/cap.day
COD biosol = 105.204 g/m³; 172765.7888 kg/y; 23.6665 g/cap.day
COD insol = 29.9942 g/m³; 49256.4169 kg/y; 6.7475 g/cap.day
COD biopart = 40.0394 g/m³; 65752.6 kg/y; 9.0072 g/cap.day
COD inpart = 20.2058 g/m³; 33182 kg/y; 4.5455 g/cap.day
Sum of COD-fractions = 320956.8057 kg/y

Volatile solids (VS) = 128.7051 g/m³; 211359.3368 kg/y; 28.9533 g/cap.day
Suspended solids (TSS) = 45.8014 g/m³; 75214.9902 kg/y; 10.3034 g/cap.day
Dissolved solids (TS-TSS) = 771.2888 g/m³; 1266609.1188 kg/y; 173.5081 g/cap.day
Fixed solids (TS-VS) = 688.385 g/m³; 1130464.7722 kg/y; 154.8582 g/cap.day
Total solids (TS) = 817.0902 g/m³; 1341824.109 kg/y; 183.8115 g/cap.day
H₂O = 1640856509.3477 kg/y; 224.7749 kg/cap.day
Total volume = 1642198.3335 m³/y; 4499.1735 m³/day

The URWARE Wastewater Treatment Plant Models

VS content = 0.012871 %
TSS content = 0.0045801 %
TS content = 0.081709 %

Total nitrogen = 80.2915 g/m³; 131854.636 kg/y; 18.0623 g/cap.day
N-NH₃ & N-NH₄ = 51.993 g/m³; 85382.8033 kg/y; 11.6963 g/cap.day
N-NO₃ = 0.072313 g/m³; 118.7522 kg/y; 0.016267 g/cap.day
N-N₂O = 0 g/m³; 0 kg/y; 0 g/cap.day
N-org,part = 3.0122 g/m³; 4946.7 kg/y; 0.67763 g/cap.day
N-org,sol = 25.214 g/m³; 41406.3806 kg/y; 5.6721 g/cap.day
Sum of N-fractions = 131854.636 kg/y
N content per TSS (N-org,part/TSS) = 6.5767 %
N content per TS (Total N/TS) = 9.8265 %

Total sulphur = 4.1149 g/m³; 6757.5064 kg/y; 0.92569 g/cap.day
SO₄-S = 2.6539 g/m³; 4358.2043 kg/y; 0.59701 g/cap.day
S particulate = 0.13409 g/m³; 220.2 kg/y; 0.030164 g/cap.day
Sulfide HS-S = 1.3269 g/m³; 2179.1021 kg/y; 0.29851 g/cap.day
Sum of S-fractions = 6757.5064 kg/y
S content per TSS (S particulate/TSS) = 0.29276 %
S content per TS (Total S/TS) = 0.50361 %

Total phosphorus = 1.2729 g/m³; 2090.4036 kg/y; 0.28636 g/cap.day
PO₄-P = 0.74985 g/m³; 1231.4036 kg/y; 0.16869 g/cap.day
P particulate = 0.52308 g/m³; 859 kg/y; 0.11767 g/cap.day
Sum of P-fractions = 2090.4036 kg/y
P content per TSS (P particulate/TSS) = 1.1421 %
P content per TS (Total P/TS) = 0.15579 %

Total potassium = 18.9059 g/m³; 31047.2337 kg/y; 4.253 g/cap.day
Dissolved potassium = 18.8059 g/m³; 30882.9837 kg/y; 4.2305 g/cap.day
Organically bound potassium = 0.10002 g/m³; 164.25 kg/y; 0.0225 g/cap.day
K content per TSS (Organically bound K/TSS) = 0.21837 %
K content per TS (Total K/TS) = 2.3138 %
Temperature in water = 20 degC

Sludge stream

BOD₇ = 22935.0667 g/m³; 395770.0071 kg/y; 54.2151 g/cap.day
COD total = 51734.977 g/m³; 892744.3943 kg/y; 122.2938 g/cap.day
COD biosol = 105.204 g/m³; 1815.4112 kg/y; 0.24869 g/cap.day
COD insol = 29.9942 g/m³; 517.5831 kg/y; 0.070902 g/cap.day
COD biopart = 34293.5597 g/m³; 591773.4 kg/y; 81.0648 g/cap.day
COD inpart = 17306.2191 g/m³; 298638 kg/y; 40.9093 g/cap.day
Sum of COD-fractions = 892744.3943 kg/y

Volatile solids (VS) = 28719.7228 g/m³; 495590.6632 kg/y; 67.8891 g/cap.day
Suspended solids (TSS) = 39228.7112 g/m³; 676934.9116 kg/y; 92.7308 g/cap.day
Dissolved solids (TS-TSS) = 771.2888 g/m³; 13309.4428 kg/y; 1.8232 g/cap.day
Fixed solids (TS-VS) = 11280.2772 g/m³; 194653.6912 kg/y; 26.6649 g/cap.day
Total solids (TS) = 40000 g/m³; 690244.3544 kg/y; 94.554 g/cap.day
H₂O = 16565864.5061 kg/y; 2.2693 kg/cap.day
Total volume = 17256.1089 m³/y; 47.277 m³/day
VS content = 2.872 %
TSS content = 3.9229 %
TS content = 4 %

Total nitrogen = 2657.2526 g/m³; 45853.84 kg/y; 6.2813 g/cap.day
N-NH₃ & N-NH₄ = 51.993 g/m³; 897.1967 kg/y; 0.1229 g/cap.day

N-NO₃ = 0.072313 g/m³; 1.2478 kg/y; 0.00017094 g/cap.day
 N-N₂O = 0 g/m³; 0 kg/y; 0 g/cap.day
 N-org,part = 2579.9733 g/m³; 44520.3 kg/y; 6.0987 g/cap.day
 N-org,sol = 25.214 g/m³; 435.0954 kg/y; 0.059602 g/cap.day
 Sum of N-fractions = 45853.84 kg/y
 N content per TSS (N-org,part/TSS) = 6.5767 %
 N content per TS (Total N/TS) = 6.6431 %

Total sulphur = 118.8271 g/m³; 2050.4936 kg/y; 0.28089 g/cap.day
 SO₄-S = 2.6539 g/m³; 45.7957 kg/y; 0.0062734 g/cap.day
 S particulate = 114.8463 g/m³; 1981.8 kg/y; 0.27148 g/cap.day
 Sulfide HS-S = 1.3269 g/m³; 22.8979 kg/y; 0.0031367 g/cap.day
 Sum of S-fractions = 2050.4936 kg/y
 S content per TSS (S particulate/TSS) = 0.29276 %
 S content per TS (Total S/TS) = 0.29707 %

Total phosphorus = 935.8771 g/m³; 16149.5964 kg/y; 2.2123 g/cap.day
 PO₄-P = 0.74985 g/m³; 12.9395 kg/y; 0.0017725 g/cap.day
 P particulate = 935.1272 g/m³; 16136.6569 kg/y; 2.2105 g/cap.day
 Sum of P-fractions = 16149.5964 kg/y
 P content per TSS (P particulate/TSS) = 2.3838 %
 P content per TS (Total P/TS) = 2.3397 %

Total potassium = 104.4712 g/m³; 1802.7663 kg/y; 0.24695 g/cap.day
 Dissolved potassium = 18.8059 g/m³; 324.5163 kg/y; 0.044454 g/cap.day
 Organically bound potassium = 85.6653 g/m³; 1478.25 kg/y; 0.2025 g/cap.day
 K content per TSS (Organically bound K/TSS) = 0.21837 %
 K content per TS (Total K/TS) = 0.26118 %
 Temperature in water = 20 degC

Extra output variables

Added FeCl₃ = 6.6068e+04 kg/y; 9.05 g/cap.day
 Amount of total energy used = 30.049 GJ/y = 8347.1 kWh/y; 1.143 Wh/cap.day
 Amount of energy used for mixing = 8.961 GJ/y = 2489.2 kWh/y; 0.341 Wh/cap.day
 Amount of energy used for sludge scrapers = 9.140 GJ/y = 2539.0 kWh/y; 0.348 Wh/cap.day
 Amount of energy used for pumping = 11.948 GJ/y = 3318.9 kWh/y; 0.455 Wh/cap.day

If the same degree of sludge concentration could be achieved in mode 0 (i.e. only a sedimentation unit but no extra thickener then the following holds:

Amount of total energy used = 21.028 GJ/y = 5841.2 kWh/y; 0.800 Wh/cap.day
 Amount of energy used for mixing = 8.961 GJ/y = 2489.2 kWh/y; 0.341 Wh/cap.day
 Amount of energy used for sludge scrapers = 8.961 GJ/y = 2489.2 kWh/y; 0.341 Wh/cap.day
 Amount of energy used for pumping = 3.106 GJ/y = 862.8 kWh/y; 0.118 Wh/cap.day

The difference is primarily related to internal pumping energy of the assumed 2% of the influent flow from the settler to the thickener and then back to the settler. The energy differences between Cases 2.1 and 2.2 are related to the energy required for mixing in the precipitation reactor.

In order to demonstrate that the behaviour of the sedimentation model is reasonable, a comparative simulation is done with the general waste water treatment plant simulator GPS-X (Hydromantis, 1999). The GPS-X model is simulated according to Figure 2.1 (mode 1), without any chemical precipitation using the default parameter set of GPS-X. Consequently, the

settler and the thickener are described as two individual 10-layer one-dimensional settler models with individual parameter sets (a classical Takács' double-exponential settling velocity model without any biological activity within the primary sedimentation unit or thickening unit (Takács *et al.*, 1991)). The actual recirculation flow rate from the thickener to the settler is also included. The influent wastewater is characterised similar to the URWARE input (although not as many variables are described in GPS-X). The underflow rate from the thickener is defined by URWARE (total_flow_sludge = 29.191 m³/d and thereby the effluent flow rate is also fixed) and the only model parameters used to modify the behaviour of the GPS-X model are the settler surface area (set to 60 m², depth 4 m), the underflow rate from the settler (set to 90.9 m³/d, i.e. 2% of the influent flow rate in the URWARE simulation) and the thickener surface area (set to 20 m², depth 1 m). A drawback of URWARE is obviously that the actual design (volumes etc.) are not directly included in any parameters and therefore reasonable values must be selected when making this type of comparative study. Based on these simple modifications we can see that the results are similar to the URWARE results. It would be possible to come even closer if the model parameters themselves (settling rate, etc.) were modified but it is certainly encouraging to see that the GPS-X model performs so similar to URWARE without any major calibration for the steady-state behaviour. It should be noted that the selected surface area of the settler gives a hydraulic load of about 3.0 m/h including the recirculation from the thickener (normal values for primary clarifiers 1-3 m/h) and a hydraulic retention time of about 0.8 hours (sludge load of about 32 kg TSS/m².d) and the selected surface area of the thickener gives a sludge load of about 60 kg TSS/m².d (normally 50-150 kg TSS/m².d for primary sludge) and a hydraulic load of 0.2 m/h. The design of the system in GPS-X could have been done somewhat differently but the purpose of this comparison is only to show the principle similarities of the two models' behaviours.

Influent wastewater (from GPS-X, URWARE inputs within parenthesis)

BOD7 = 334.5 g/m³ (334.4)

COD total = 731.5 g/m³ (731.5)

COD biosol = 105.2 g/m³ (105.2)

COD insol = 30 g/m³ (30)

COD biopart = 396.3 g/m³ (396.3)

COD inpart = 200 g/m³ (200)

Volatile suspended solids (VSS) = 335.9 g/m³ (not used in URWARE but a backward calculation indicates a value of about 384 g/m³)

Suspended solids (TSS) = 419.9 g/m³ (419.9)

Flow rate = 4545.545 m³/d (4545.545)

VSS content = 0.03359 % (not used in URWARE but 0.0384%)

TSS content = 0.04199 % (0.04199)

Total nitrogen = 107.1 g/m³ (107.1)

N-NH₃ & N-NH₄ = 52 g/m³ (52)

N-NO₃ = 0.07 g/m³ (0.07)

N-org,part = 29.82 g/m³ (29.82)

N-org,sol = 25.22 g/m³ (25.2)

Effluent wastewater (from GPS-X, URWARE results (Case 2.1) within parenthesis)

BOD7 = 176.4 g/m3 (176.5)
 COD total = 374.9 g/m3 (375.3)
 COD biosol= 105.2 g/m3 (105.2)
 COD insol = 30 g/m3 (30)
 COD biopart = 159.3 g/m3 (159.5)
 COD inpart = 80.4 g/m3 (80.5)

Volatile suspended solids (VSS) = 135.0 g/m3 (not used in URWARE but about 153.6 g/m3)
 Suspended solids (TSS) = 168.8 g/m3 (169.1)
 Flow rate (effluent) = 4516.4 m3/d (4516.4)
 VSS content = 0.0135 % (not available in URWARE but 0.0153%)
 TSS content = 0.01682 % (0.016906)

Total nitrogen = 89.3 g/m3 (89.3)
 N-NH3 & N-NH4 = 52 g/m3 (52)
 N-NO3 = 0.07 g/m3 (0.07)
 N-org,part = 12.0 g/m3 (12.0)
 N-org,sol = 25.22 g/m3 (25.2)

Sludge stream (from GPS-X, URWARE results (Case 2.1) within parenthesis)

BOD7 = 24792 g/m3 (24758.0)
 COD total = 55904 g/m3 (55848.8)
 COD biosol= 105.2 g/m3 (105.2)
 COD insol = 30 g/m3 (30)
 COD biopart = 37064 g/m3 (37027.6)
 COD inpart = 18705 g/m3 (18686.0)

Volatile suspended solids (VSS) = 31419 g/m3 (not used in URWARE but about 35910 g/m3)
 Suspended solids (TSS) = 39274 g/m3 (39235.0)
 Flow rate (underflow) = 29.191 m3/d (29.191)
 VSS content = 3.1419 % (not used in URWARE but 3.59%)
 TSS content = 3.9274 % (3.9235)

Total nitrogen = 2866.2 g/m3 (2863.0)
 N-NH3 & N-NH4 = 52 g/m3 (52)
 N-NO3 = 0.07 g/m3 (0.07)
 N-org,part = 2788.9 g/m3 (2785.7)
 N-org,sol = 25.22 g/m3 (25.2)

2.2 Final sedimentation

The behaviour of the final sedimentation model is implemented equivalently to the primary sedimentation unit. Note that the final sedimentation unit does not represent the secondary clarifier used as part of an activated sludge system but a final polishing sedimentation unit found at some plants (in particular in plants where postprecipitation is applied). The code is available in Appendix J. It is influenced by ten user-defined parameters, which are defined in the initialisation file `spInit.m`. These are:

- **spPostSSludgeTSPerc**: defines the total solids content (TS) of the sludge stream (%). Suggested value is 2% in mode 1 and 0.5% in mode 0 (Balmér, 2004).
- **spPostSRed**: defines the reduction of total suspended solids (TSS) in

the effluent compared to the influent content (%). Suggested value is 80-90% when precipitation is active. In case no precipitation is applied a value of <25% may be used if the influent represents wastewater from a preceding activated sludge settler whereas a value of 50-70% may be realistic if the influent comes directly from a preceding biofilm process (Balmér, 2004).

- **spPostSFeCl3In**: defines the concentration of added precipitation chemicals, i.e. kg FeCl₃ per kg solution (chemical + water). Suggested value 0.2.
- **spPostSPO4Out**: defines the requested effluent concentration of PO₄-P. If the value is higher than the influent concentration the model adjusts the value to equal the influent concentration (i.e. precipitation deactivated) and if it is lower than the influent concentration then the chemical precipitation part of the model is activated. Suggested value when using chemical precipitation together with final sedimentation is 0.1-0.3 mg PO₄-P/l. Note that this variable (element 79) also represents other forms of soluble P (organic) present in the wastewater (as discussed in Section 2.1).
- **spCODtoVS(1,1)**: conversion factor for calculating volatile solids (VS) from biodegradable COD fractions. Suggested value $1/1.42 \approx 0.704$ (Metcalf & Eddy, 1991).
- **spCODtoVS(2,1)**: conversion factor for calculating volatile solids (VS) from non-biodegradable COD fractions. Suggested value $1/1.9 \approx 0.526$.
- **spPostSMode**: defines the mode the model is operating in (only sedimentation unit (mode 0) or sedimentation and thickening combined (mode 1)).
- **spPostSEnergy(1,1)**: defines the energy required for mixing when precipitation is active. Suggested value 5400 J/m³ of influent flow (= 1.5 Wh/m³).
- **spPostSEnergy(2,1)**: defines the energy required for sludge scrapers. Suggested value 5400 J/m³ of influent flow (= 1.5 Wh/m³).
- **spPostSEnergy(3,1)**: defines the energy required for pumping. Suggested value 180000 J/m³ of pumped flow (= 50 Wh/m³).

The above ten parameters are gathered into a vector (spPostSPAR) and included as an argument when calling the actual final sedimentation model (spPostSModel.m). Consequently, the user has easy access to all model parameters in a specific text file and new parameters can easily be added when the need arise, thus promoting the future flexibility of the program. The parameter values may very well be different from the ones used to define the primary sedimentation process and, certainly, the characteristics of the wastewater into the two processes will often be very different. For the final sedimentation process the behaviour (and therefore the defined parameter values) will be strongly related to how the wastewater has been treated prior to this process. However, the principles defined in Tables 2.1-2.3 are valid also for the final sedimentation unit. Therefore no example of results is provided for this model. For simplicity the energy calculations are also carried out in the same manner as in the primary sedimentation model.

2.3. Concluding comments

The behaviour of the sedimentation process is highly complex and requires models of high complexity to include at least some of the physical mechanisms. However, for the purpose of URWARE (steady state results based on yearly averages) simplicity is a priority. For this reason some rough assumptions are used in the described models and the user must bear this in mind when interpreting the models and the results of any simulations. The models do not describe reality but rather a rough simplification of reality with the intent of providing reasonable results during normal operation conditions. The models should not be used to investigate any type of extreme operational conditions nor any dynamics or disturbances in the influent wastewater characteristics.

A possible extension to the discussed sedimentation processes is to include polymers and their effect on the settling process. However, at this stage of the modelling work it has been neglected. The primary importance of polymer addition and the consequent change of behaviour is probably in the dewatering process.

A few open questions and issues that should be resolved in the future for the primary and final sedimentation processes are:

- Phosphorus release of previously biologically enhanced biomass P-uptake?
- Stripping of nitrate (denitrification)?
- Fermentation and hydrolysis (priority in primary sedimentation tanks)?
- Effect of chemical precipitation on other variables, e.g. TSS, particulate COD? Particle reduction could be automatically adjusted according to amount of precipitants added.
- Precipitants that stay in the water phase and are recycled back?
- Non-ideal precipitation, e.g. precipitants that react with other components than the intended phosphate?
- Precipitants already added to the water in other stages may improve settling?

Addition of other chemicals such as organic polymers, AlSO_4 and lime?

3 Thickening

Although the behaviour of a thickener can be included as part of a primary and final sedimentation system in URWARE, a stand-alone thickening module also exists. The code is available in Appendix K. The thickener model is based on the same principles as used to model the sedimentation units in Chapter 2 although somewhat simplified. Firstly, no chemical precipitation part can be activated for the thickener and secondly it cannot be operated in different modes (i.e. it is only a thickener). The input and outputs are shown in Figure 3.1.

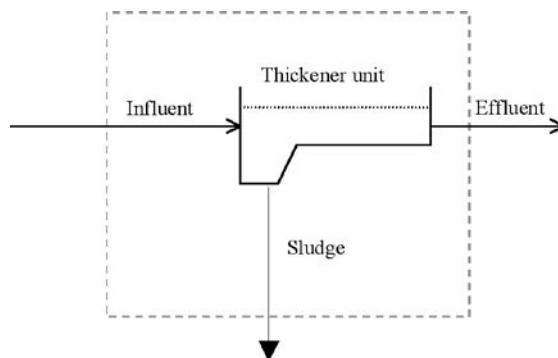

Figure 3.1
General flow scheme for
the thickener model.

The single difference compared to the model described in Chapter 2 is that since no chemically precipitated phosphorus is created in this system, all particulate P is divided between the two output streams equivalently to the TSS (and other particulates) separation.

The model is influenced by six user-defined parameters, which are defined in the initialisation file `spInit.m`. These are:

- **spThickSludgeTSPerc**: defines the total solids content (TS) of the sludge stream (%). Suggested value is 4-6%. Note that this value can vary substantially depending on the type of sludge (e.g. primary or secondary sludge with or without preceding precipitation).
- **spThickRed**: defines the reduction of total suspended solids (TSS) in the effluent compared to the influent content (%). Suggested value is 70-90%. Note that this value can vary substantially depending on the type

of sludge (e.g. primary or secondary sludge with or without preceding precipitation).

- **spCODtoVS(1,1)**: conversion factor for calculating volatile solids (VS) from biodegradable COD fractions. Suggested value $1/1.42 \approx 0.704$ (Metcalf & Eddy, 1991).
- **spCODtoVS(2,1)**: conversion factor for calculating volatile solids (VS) from non-biodegradable COD fractions. Suggested value $1/1.9 \approx 0.526$.
- **spThickEnergy(1,1)**: defines the energy required for sludge scrapers. Suggested value 5400 J/m^3 of influent flow ($= 1.5 \text{ Wh/m}^3$).
- **spThickEnergy(2,1)**: defines the energy required for pumping. Suggested value 180000 J/m^3 of pumped flow ($= 50 \text{ Wh/m}^3$).

The above six parameters are gathered into a vector (spThickPAR) and included as an argument when calling the actual thickening model (spThickModel.m). Consequently, the user has easy access to all model parameters in a specific text file and new parameters can easily be added when the need arise, thus promoting the future flexibility of the program. The parameter values may very well be different from the ones used to define the sedimentation processes. However, the principles defined in Tables 2.1-2.3 are valid also for the thickener unit (when precipitation is deactivated and operating in mode 0). The energy calculations are also somewhat simpler and include only energy for pumping (both the sludge flow and effluent flow is by default assumed to require pumping as the effluent flow is normally recycled as return liquors) and energy for the sludge scrapers. The same default values (as used in the sedimentation models) for the amounts of energy per m^3 are used also here (see pseudo-code below). The energy consumption is the only extra variable produced by this model (three specific outputs – total energy, energy for sludge scrapers and energy for pumping).

```
pumpingenergy = spThickEnergy(2,1)*3600*totalflow_in/1000; %J/year
sludgeremenergy = spThickEnergy(1,1)*3600*totalflow_in/1000; %J/year
energy = pumpingenergy + sludgeremenergy; %J/year
```

In order to account for the different energy efficiencies for small and large plants a special function is used by which all energy values are multiplied in all models. The shape of this function is defined by the user and simply represents the fact that the energy requirements for a small plant is normally higher than that of a large plant per m^3 of treated wastewater since large electrical drives are normally more efficient than small ones. The energy adjustment function is further discussed in Chapter 9. The values suggested for the three spThickEnergy parameters represent the situation at a large and energy-efficient WWTP.

As the model produces results, which are a subset of the sedimentation models, no explicit results are shown for this module.

4

Dewatering

The dewatering model describes the separation of sludge and water phase. At this stage the process is considered to be a centrifuge but this limitation only has an impact in terms of energy use for the process and the type and amount of sludge conditioners to use. Organic polymers are assumed to be used for sludge conditioning if the user activates this possibility (by defining the addition of kg of polymers per ton TS and also the concentration of the polymer solution). Should no polymers be used (highly unusual), this is simply accomplished by changing a model parameter in the initialisation file. The code is available in Appendix L. The principle of the model and its system borders are shown in Figure 4.1.

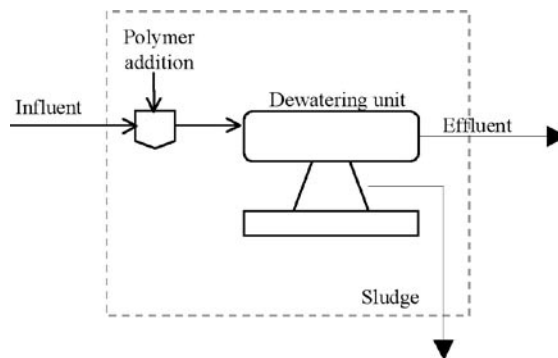

Figure 4.1
General flow scheme for
the dewatering model.

The behaviour of the dewatering model is influenced by seven user-defined parameters, which are defined in the initialisation file `spInit.m`. These are:

- **spDewSludgeTSPerc**: defines the total solids content (TS) of the sludge stream (%). Suggested value is 25-30% (Hellström, 2004). If no polymers are used this value should be somewhat reduced.
- **spDewRed**: defines the reduction of total suspended solids (TSS) in the effluent compared to the influent content (%). Suggested value is 95-99% (Hellström, personal communication) when polymers are added.

- **spDewPolyIn**: defines the concentration of added organic polymers, i.e. kg polymer per kg solution (polymer + water). Suggested value 0.001 (Balmér, 2004). If **spDewPolyIn** is set to 1 then the polymers are added in dry form, i.e. no water is added to the mass balances. A value of 1 should not be used for realistic simulations but may be useful for specific simulations studies.
- **spDewPolyRatio**: defines the addition ratio of organic polymers for sludge conditioning. Suggested value when using organic polymers and a centrifuge process is 4-7 kg polymer per ton TS (Hellström, personal communication). However, the addition of polymers may be quite different for different types of sludge. A value of 0 represents that no polymers are added to the dewatering unit (highly unusual).
- **spCODtoVS(1,1)**: conversion factor for calculating volatile solids (VS) from biodegradable COD fractions. Suggested value $1/1.42 \approx 0.704$ (Metcalf & Eddy, 1991).
- **spCODtoVS(2,1)**: conversion factor for calculating volatile solids (VS) from non-biodegradable COD fractions. Suggested value $1/1.9 \approx 0.526$.
- **spDewEnergy**: energy use per m^3 of influent flow. Suggested value 5200000 J/m^3 ($= 1.44 \text{ kWh/m}^3$). This factor represents an aggregation of all different energy requirements.

The above seven parameters are gathered into a vector (**spDewPAR**) and included as an argument when calling the actual dewatering model (**spDewModel.m**). Consequently, the user has easy access to all model parameters in a specific text file and new parameters can easily be added when the need arise, thus promoting the future flexibility of the program.

Due to the fact that the addition of organic polymers is internal within the model (when activated) and the added polymers not a traditional input variable, we first need to make the calculations related to this process. The reason for this is that it will have an effect on the TS, TSS, VS and water content (and in future model extensions possibly on other variables), which in turn will influence the dewatering process. We also suggest that organic polymers are included as inert particulate COD (and consequently also as total COD). We are assuming that organic polymers are used (at this stage addition of FeCl_3 , lime or other conditioners are not considered) with a VS:TS ratio of 0.8. The user controls this part of the model by adjusting the parameters **spDewPolyIn** and **spDewPolyRatio**. When polymers are added for sludge conditioning the dewatering capacity is generally improved. Therefore the user parameters **spDewSludgeTSPerc** and **spDewRed** should also be adjusted to take this into account. Other more detailed changes to the behaviour of the dewatering process due to addition of polymers are currently neglected. The transformations are summarised in Table 4.1. It must be noted that before the new values of elements 7, 8, 22, 42, 43 and 78 are calculated, the entire original input vector has been transformed into mass units by the function **conc2load**. Once the new values of the six variables have been calculated, the function **load2conc** is used to transform the entire vector into concentra-

tions again and thereby taking into account the new values for TS and H₂O caused by the added polymers (which will slightly affect all variables in the vector on a concentration basis).

Position. Variable	Relationship	Comment
7. VS	$VS_in + 0.8 * addedpoly$	assume $VSpoly/TSpoly = 0.8$
8. TS	$TS_in + addedpoly$	
22. H2O	$H2O_in + addedH2O$	extra H2O in polymer solution
42. TSS	$TSS_in + addedpoly$	all polymers in the sludge phase
43. COD_total	$COD_total_in + addedpoly * 0.8 / spCODtoVS(2,1)$	
78. COD_part,inert	$COD_part,inert_in + addedpoly * 0.8 / spCODtoVS(2,1)$	Assume polymers have the same VS:COD ratio as inert COD.
Help variables		
	$addedpoly = spDewPolyRatio * TS_in$	mass (spDewPolyRatio (kg/kg))
	$addedH2O = addedpoly * (1 - spDewPolyIn) / spDewPolyIn$	mass (= volume)

Table 4.1
Description of the polymer addition processes.

Once the internal modifications of the variables in the vector affected by the polymers have been made, it is possible to model the actual dewatering process. The user defines the requested TS concentration in the sludge stream (% TS, **spDewSludgeTSPerc**) and also the reduction of suspended solids in the effluent (**spDewRed**). Based on these two parameters, the fundamental behaviour of the dewatering process is more or less fixed (same principle as previously described for the sedimentation process). We assume that $TS_dissolved = TS - TSS$. The fundamental equation is based on a mass balance over the dewatering process. In terms of TS and water (units kg/y), this means:

$$\begin{aligned} TS_in &= TS_effluent + TS_sludge \\ H2O_in &= H2O_effluent + H2O_sludge \\ totalflow_in &= totalflow_effluent + totalflow_sludge \end{aligned}$$

where TS_in , $H2O_in$ and $totalflow_in (= TS_in + H2O_in)$ are the adjusted variables after the polymer addition (mass units). We also know that by definition

$$\begin{aligned} TS_sludge / totalflow_sludge &= spDewSludgeTSPerc \\ totalflow_sludge &= TS_sludge + H2O_sludge \\ totalflow_effluent &= totalflow_in - totalflow_sludge \end{aligned}$$

which means that:

$$TS_sludge / H2O_sludge = spDewSludgeTSPerc / (1 - spDewSludgeTSPerc)$$

by using the following rewriting:

$$\begin{aligned} TS_sludge / H2O_sludge &= TS_sludge / (totalflow_sludge - TS_sludge) \\ &= TS_sludge / (totalflow_sludge - spDewSludgeTSPerc * totalflow_sludge) \\ &= TS_sludge / (totalflow_sludge * (1 - spDewSludgeTSPerc)) \\ &= spDewSludgeTSPerc / (1 - spDewSludgeTSPerc) \end{aligned}$$

However, the TS concentration must also be in accordance with the user-defined request that **spDewRed** % of the TSS should end up in the sludge stream, i.e.

$$\text{totalflow_in} * \text{TSS_in} = \text{totalflow_effluent} * \text{TSS_effluent} + \text{totalflow_sludge} * \text{TSS_sludge}$$

(mass balance for TSS in unit kg/y * mg/dm³ = mg/y)

$$\text{TSS_sludge} = (\text{spDewRed} * \text{TSS_in} * \text{totalflow_in}) / \text{totalflow_sludge}$$

(based on definition of **spDewRed**)

$$\text{TSS_effluent} = ((1 - \text{spDewRed}) * \text{TSS_in} * \text{totalflow_in}) / \text{totalflow_effluent}$$

(i.e. the remaining fraction of TSS, which means (1 – **spDewRed**), ends up in the effluent) = (TSS_in * totalflow_in – TSS_sludge * totalflow_sludge) / (totalflow_in – totalflow_sludge)

and consequently all details with regard to the TSS concentrations can be determined if we can find the value of totalflow_sludge. There is only one problem – the totalflow_sludge is a function of TS (and therefore of TSS and TS_dissolved) since totalflow_sludge = H2O_sludge + TS_sludge. In order to avoid having to iterate a solution to the above problem a small simplification is necessary. We simply assume that TS_dissolved is only a function of the water fraction and not the total volume (water + TS). This simplification has rather small effects as the water volume is always higher than the TS volume (although the effect is somewhat more apparent in the dewatering unit compared to the sedimentation and thickening units). We can now solve the above system and uniquely determine totalflow_sludge. The resulting equation is:

$$\text{totalflow_sludge} = (\text{spDewRed} * \text{TSS_in} * \text{totalflow_in}) / \text{TSS_sludge}$$

$$= (\text{spDewRed} * \text{TSS_in} * \text{totalflow_in}) / (10^6 * (\text{spDewSludgeTSPerc} - \text{TS_in} / \text{totalflow_in}) - \text{TSS_in})$$

note: **spDewSludgeTSPerc** * 10⁶ = TS_sludge in mg/dm³ (since we assume 1 kg = 1 dm³) so

$$\text{TSS_sludge (mg/dm}^3) = 10^6 * (\text{spDewSludgeTSPerc} - \text{TS_in} / \text{totalflow_in}) - \text{TSS_in} = \text{TS_sludge (mg/dm}^3) - \text{TS_in (mg/dm}^3) - \text{TSS_in (mg/dm}^3) = \text{TS_sludge (mg/dm}^3) - \text{TS_dissolved_in (mg/dm}^3)$$

$$\text{kg/kg} = \text{kg/dm}^3 = 10^6 \text{ mg/dm}^3$$

where the nominator represents the *mass* of TSS_sludge (in mg TSS/y if the default units are used) and the denominator represents the *concentration* of TSS_sludge (expressed as requested TS_sludge concentration – TS_dissolved concentration assuming that the TS_dissolved concentration is not affected by the increased concentration of TSS in the sludge flow compared to the influent). The problem can also be stated as: **spDewRed** allows us to calculate how much mass of TSS should be in the sludge flow and in order to reach the defined TS concentration we must add some water (which then includes TS_dissolved) as well. As the ratio TSS:TS_dissolved will be different in the influent and the sludge flow (since TSS settles due to gravity forces) and the total volume of the sludge flow is water + TS, the difficulty appear. We cannot include the actual volume of the TS_dissolved as such, instead we assume that the TS_dis-

solved concentration will be same in the influent and the sludge flow, which is not exactly true since a somewhat larger part of the TS volume will now be made up of TSS (and therefore the TS_dissolved concentration slightly lower based on a grab sample). The same problem currently holds for all solubles although it would be possible to compensate for this effect for all solubles except TS_dissolved since the soluble compounds must exist within the volume made up by water + TS – TSS*totalflow in the different streams. However, this type of detailed compensation would serve no practical purpose at this stage. Another detail not yet fully accounted for is the COD content of organic polymers. In Table 4.1 it is clear that we are currently using a value of 1.52 g COD/g polymer. This value may need adjustment.

Based on the above we can now formulate the expressions for calculating the different flow streams out from the dewatering process (assumed to be continuous). This is shown in Table 4.2. Note that all in-variables have already been adjusted for the effects caused by the polymer addition.

Help variable	Relationship	Comment
totalflow_in	= H2O_in + TS_in	Adjusted for polymer addition
totalflow_sludge	= (TSS_in*totalflow_in*spDewRed) / (spDewSludgeTSPerc – TS_in/totalflow_in – TSS_in)	TSS_in as concentration
H2Oflow_sludge	= totalflow_sludge * (1 – spDewSludgeTSPerc)	
TSflow_sludge	= totalflow_sludge – H2Oflow_sludge	
totalflow_effluent	= totalflow_in – totalflow_sludge	
TSflow_effluent	= TS_in – TSflow_sludge	
H2Oflow_effluent	= totalflow_effluent – TSflow_effluent	

Table 4.2
Calculating the different flows (water phase and total).

Once these fundamental expressions have been defined we can easily calculate the behaviour for the other priority variables in the URWARE vector. At this stage the behaviour is simply a matter of whether a variable is dissolved (in which case the influent concentration is equivalent to the output concentration) or particulate (in which case the variable will behave in the same way as the TSS variable). VS is calculated based on the defined conversion parameters whereas BOD in the output streams is proportional to the BOD:COD_biodegradable ratio in the influent and the same ratio is assumed in the two output streams. This is a reasonable assumption as biological activity in the dewatering unit is not assumed to occur. In Table 4.3 the calculations are shown for all variables in the effluent flow stream.

Position. variable name	Relationship	Comment
6. BOD	$= \text{in}(6) * (\text{out}(75) + \text{out}(77)) / (\text{in}(75) + \text{in}(77))$	Calculated once effluent variables 75 and 77 are known
7. Volatile solids (VS)	$= \text{spCODtoVS}(1,1) * (\text{out}(75) + \text{out}(77)) + \text{spCODtoVS}(2,1) * (\text{out}(76) + \text{out}(78))$	Calculated once effluent variables 75, 76, 77 and 78 are known
8. Total solids (TS)	$= \text{TSflow_effluent}$	See Table 4.2, mass unit
22. Water	$= \text{H2Oflow_effluent}$	See Table 4.2, mass unit
23. Total nitrogen (N-tot)	$= \text{out}(24) + \text{out}(26) + \text{out}(44) + \text{out}(81)$	Calculated once effluent variables 24, 26, 44 and 81 are known
24. Ammonia/ammonium	$= \text{in}(24)$	$\text{NH4_out} = \text{NH4_in}$
26. Nitrate/nitrite	$= \text{in}(26)$	$\text{NO3_out} = \text{NO3_in}$
28. Total sulphur (S-tot)	$= \text{out}(29) + \text{out}(46)$	Calculated once effluent variables 29 and 46 are known
29. Sulphate	$= \text{in}(29)$	$\text{SO4_out} = \text{SO4_in}$
30. Total phosphorus (P-tot)	$= \text{out}(79) + \text{out}(80)$	Calculated once effluent variables 79 and 80 are known
32. Total potassium (K-tot)	$= (\text{in}(32) - \text{in}(49)) + \text{in}(49) * \text{totalflow_in} * (1 - \text{spDewRed}) / \text{totalflow_effluent}$	$\text{K_out} = \text{K_in_dissolved} + \text{organically bound K equivalent to TSS}$
42. Suspended solids (TSS)	$= \text{in}(42) * \text{totalflow_in} * (1 - \text{spDewRed}) / \text{totalflow_effluent}$	
43. Total COD	$= (\text{in}(43) * \text{totalflow_in} - (\text{in}(75) + \text{in}(76)) * \text{totalflow_sludge} - \text{spDewRed} * (\text{in}(77) + \text{in}(78)) * \text{totalflow_in}) / \text{totalflow_effluent}$	Equivalent to $\text{out}(75) + \text{out}(76) + \text{out}(77) + \text{out}(78)$
44. Soluble organic nitrogen	$= \text{in}(44)$	$\text{Norg,sol_out} = \text{Norg,sol_in}$
46. Particulate sulphur	$= \text{in}(46) * \text{totalflow_in} * (1 - \text{spDewRed}) / \text{totalflow_effluent}$	Equivalent to TSS
48. Sulfide (HS-S)	$= \text{in}(48)$	
49. Organically bound potassium	$= \text{in}(49) * \text{totalflow_in} * (1 - \text{spDewRed}) / \text{totalflow_effluent}$	Equivalent to TSS
75. COD, soluble&biodreg	$= \text{in}(75)$	$\text{CODsol,bio_out} = \text{CODsol,bio_in}$
76. COD, soluble&inert	$= \text{in}(76)$	$\text{CODsol,inert_out} = \text{CODsol,inert_in}$
77. COD, part&biodreg	$= \text{in}(77) * \text{totalflow_in} * (1 - \text{spDewRed}) / \text{totalflow_effluent}$	Equivalent to TSS
78. COD, part&inert	$= \text{in}(78) * \text{totalflow_in} * (1 - \text{spDewRed}) / \text{totalflow_effluent}$	Equivalent to TSS
79. Phosphate	$= \text{in}(79)$	$\text{PO4_out} = \text{PO4_in}$
80. Phosphorus, particulate	$= \text{in}(80) * \text{totalflow_in} * (1 - \text{spDewRed}) / \text{totalflow_effluent}$	Equivalent to TSS
81. Nitrogen, org&particulate	$= \text{in}(81) * \text{totalflow_in} * (1 - \text{spDewRed}) / \text{totalflow_effluent}$	Equivalent to TSS
82. Temperature	$= \text{in}(82)$	

Table 4.3
Calculating the variables in the effluent stream.

When all the variables in the effluent vector have been calculated the easiest (and safest) way to determine the variables in the sludge vector is to use the appropriate mass balance. This means that for each variable in the sludge output the following calculation is carried out:

sludge variable =

$$\frac{(\text{influent variable} * \text{totalflow_in} - \text{effluent variable} * \text{totalflow_effluent})}{\text{totalflow_sludge}}$$

Finally, two extra variables are given in the output vector:

- addedpoly;
- energy use.

The calculation of added polymers was described already in Table 4.1.

Energy use is calculated in relation to influent flow so that the energy use automatically adjusts. In this case it is simply assumed that the energy requirements are 1.44 kWh per m³ of influent flow to the unit (5200 kJ/m³). Note that this figure is based on centrifuges whereas the energy requirements for other dewatering processes may be different (for example lower for band filters). It could be extended so the energy use is also a function of the requested TS percentage in the dewatered sludge, i.e. higher TS demands require more energy. The energy for mixing polymers into the system is not explicitly defined and is considered negligible. The same type of energy adjustment function as previously described is also used by the dewatering model.

A few open questions that may have to be considered in the future for the dewatering process are:

- Effect of polymers on other variables?
- Polymers that remain in the water phase and are recycled back to other processes?
- Release of other compounds due to centrifuge action, cells breaking, etc.?
- Addition of other chemicals, such as FeCl₃ and lime?
- How stable is the dewatered sludge?
- What happens to the dissolved substances in the sludge when stored – are they volatile and release into the air or do they stay in the sludge when the water continues to evaporate?

To demonstrate the general behaviour of the model, a simulation case is presented below. The contents of the influent wastewater are identical to the contents of the sludge stream for simulation Case 2.2 in Section 2.1 – Primary sedimentation. Consequently this is a case of dewatering primary sludge with a TS content of 4%. In the case below the polymers are added in pure form simply to minimise their effect on the overall flow volume and enhance the later comparison of the results with a commercial simulator (GPS-X). In reality this is not realistic. Note that the energy adjustment function is not activated in the case shown below.

Case 4.1: Dewatering of primary sludge using 5 g polymers/kg TS.

Model parameters: **spDewSludgeTSPerc** = 0.30 (30%)
spDewRed = 0.95 (95%)
spDewPolyIn = 1 (i.e. pure polymers, no water)
spDewPolyRatio = 0.005 (5 kg/ton TS)
spCODtoVS(1,1) = 1/1.42 (g VS/g COD_biodegradable)
spCODtoVS(2,1) = 1/1.9 (g VS/g COD_inert)
spDewEnergy = 5200000 J/m³

Influent wastewater

BOD7 = 22935.0667 g/m³; 395770.0071 kg/y; 54.2151 g/cap.day
 COD total = 51734.977 g/m³; 892744.3943 kg/y; 122.2938 g/cap.day
 COD biosol = 105.204 g/m³; 1815.4112 kg/y; 0.24869 g/cap.day
 COD insol = 29.9942 g/m³; 517.5831 kg/y; 0.070902 g/cap.day
 COD biopart = 34293.5597 g/m³; 591773.4 kg/y; 81.0648 g/cap.day
 COD inpart = 17306.2191 g/m³; 298638 kg/y; 40.9093 g/cap.day
 Sum of COD-fractions = 892744.3943 kg/y

Volatile solids (VS) = 28719.7228 g/m³; 495590.6632 kg/y; 67.8891 g/cap.day
 Suspended solids (TSS) = 39228.7112 g/m³; 676934.9116 kg/y; 92.7308 g/cap.day
 Dissolved solids (TS-TSS) = 771.2888 g/m³; 13309.4428 kg/y; 1.8232 g/cap.day
 Fixed solids (TS-VS) = 11280.2772 g/m³; 194653.6912 kg/y; 26.6649 g/cap.day
 Total solids (TS) = 40000 g/m³; 690244.3544 kg/y; 94.554 g/cap.day
 H2O = 16565864.5061 kg/y; 2.2693 kg/cap.day
 Total volume = 17256.1089 m³/y; 47.277 m³/day
 VS content = 2.872 %
 TSS content = 3.9229 %
 TS content = 4 %

Total nitrogen = 2657.2526 g/m³; 45853.84 kg/y; 6.2813 g/cap.day
 N-NH₃ & N-NH₄ = 51.993 g/m³; 897.1967 kg/y; 0.1229 g/cap.day
 N-NO₃ = 0.072313 g/m³; 1.2478 kg/y; 0.00017094 g/cap.day
 N-N₂O = 0 g/m³; 0 kg/y; 0 g/cap.day
 N-org,part = 2579.9733 g/m³; 44520.3 kg/y; 6.0987 g/cap.day
 N-org,sol = 25.214 g/m³; 435.0954 kg/y; 0.059602 g/cap.day
 Sum of N-fractions = 45853.84 kg/y
 N content per TSS (N-org,part/TSS) = 6.5767 %
 N content per TS (Total N/TS) = 6.6431 %

Total sulphur = 118.8271 g/m³; 2050.4936 kg/y; 0.28089 g/cap.day
 SO₄-S = 2.6539 g/m³; 45.7957 kg/y; 0.0062734 g/cap.day
 S particulate = 114.8463 g/m³; 1981.8 kg/y; 0.27148 g/cap.day
 Sulfide HS-S = 1.3269 g/m³; 22.8979 kg/y; 0.0031367 g/cap.day
 Sum of S-fractions = 2050.4936 kg/y
 S content per TSS (S particulate/TSS) = 0.29276 %
 S content per TS (Total S/TS) = 0.29707 %

Total phosphorus = 935.8771 g/m³; 16149.5964 kg/y; 2.2123 g/cap.day
 PO₄-P = 0.74985 g/m³; 12.9395 kg/y; 0.0017725 g/cap.day
 P particulate = 935.1272 g/m³; 16136.6569 kg/y; 2.2105 g/cap.day
 Sum of P-fractions = 16149.5964 kg/y
 P content per TSS (P particulate/TSS) = 2.3838 %
 P content per TS (Total P/TS) = 2.3397 %

The URWARE Wastewater Treatment Plant Models

Total potassium = 104.4712 g/m³; 1802.7663 kg/y; 0.24695 g/cap.day
Dissolved potassium = 18.8059 g/m³; 324.5163 kg/y; 0.044454 g/cap.day
Organically bound potassium = 85.6653 g/m³; 1478.25 kg/y; 0.2025 g/cap.day
K content per TSS (Organically bound K/TSS) = 0.21837 %
K content per TS (Total K/TS) = 0.26118 %
Temperature in water = 20 degC

Effluent wastewater

BOD7 = 1376.666 g/m³; 20786.9011 kg/y; 2.8475 g/cap.day
COD total = 3101.0314 g/m³; 46823.8728 kg/y; 6.4142 g/cap.day
COD biosol = 105.1829 g/m³; 1588.2046 kg/y; 0.21756 g/cap.day
COD insol = 29.9882 g/m³; 452.8053 kg/y; 0.062028 g/cap.day
COD biopart = 1959.5857 g/m³; 29588.67 kg/y; 4.0532 g/cap.day
COD inpart = 1006.2745 g/m³; 15194.1929 kg/y; 2.0814 g/cap.day
Sum of COD-fractions = 46823.8728 kg/y

Volatile solids (VS) = 1999.4639 g/m³; 30190.8077 kg/y; 4.1357 g/cap.day
Suspended solids (TSS) = 2253.016 g/m³; 34019.3067 kg/y; 4.6602 g/cap.day
Dissolved solids (TS-TSS) = 771.1345 g/m³; 11643.7085 kg/y; 1.595 g/cap.day
Fixed solids (TS-VS) = 1024.6867 g/m³; 15472.2075 kg/y; 2.1195 g/cap.day
Total solids (TS) = 3024.1506 g/m³; 45663.0152 kg/y; 6.2552 g/cap.day
H₂O = 15053788.5304 kg/y; 2.0622 kg/cap.day
Total volume = 15099.4515 m³/y; 41.3684 m³/day
VS content = 0.19995 %
TSS content = 0.2253 %
TS content = 0.30242 %

Total nitrogen = 224.6874 g/m³; 3392.6567 kg/y; 0.46475 g/cap.day
N-NH₃ & N-NH₄ = 51.9826 g/m³; 784.9087 kg/y; 0.10752 g/cap.day
N-NO₃ = 0.072298 g/m³; 1.0917 kg/y; 0.00014954 g/cap.day
N-N₂O = 0 g/m³; 0 kg/y; 0 g/cap.day
N-org,part = 147.4236 g/m³; 2226.015 kg/y; 0.30493 g/cap.day
N-org,sol = 25.209 g/m³; 380.6414 kg/y; 0.052143 g/cap.day
Sum of N-fractions = 3392.6567 kg/y
N content per TSS (N-org,part/TSS) = 6.5434 %
N content per TS (Total N/TS) = 7.4298 %

Total sulphur = 10.5425 g/m³; 159.1863 kg/y; 0.021806 g/cap.day
SO₄-S = 2.6534 g/m³; 40.0642 kg/y; 0.0054882 g/cap.day
S particulate = 6.5625 g/m³; 99.09 kg/y; 0.013574 g/cap.day
Sulfide HS-S = 1.3267 g/m³; 20.0321 kg/y; 0.0027441 g/cap.day
Sum of S-fractions = 159.1863 kg/y
S content per TSS (S particulate/TSS) = 0.29128 %
S content per TS (Total S/TS) = 0.34861 %

Total phosphorus = 54.1843 g/m³; 818.1529 kg/y; 0.11208 g/cap.day
PO₄-P = 0.7497 g/m³; 11.3201 kg/y; 0.0015507 g/cap.day
P particulate = 53.4346 g/m³; 806.8328 kg/y; 0.11053 g/cap.day
Sum of P-fractions = 818.1529 kg/y
P content per TSS (P particulate/TSS) = 2.3717 %
P content per TS (Total P/TS) = 1.7917 %

Total potassium = 23.6972 g/m³; 357.8142 kg/y; 0.049016 g/cap.day
Dissolved potassium = 18.8021 g/m³; 283.9017 kg/y; 0.038891 g/cap.day
Organically bound potassium = 4.895 g/m³; 73.9125 kg/y; 0.010125 g/cap.day
K content per TSS (Organically bound K/TSS) = 0.21727 %
K content per TS (Total K/TS) = 0.7836 %
Temperature in water = 20 degC

Sludge stream

BOD7 = 173594.567 g/m³; 374983.106 kg/y; 51.3675 g/cap.day
 COD total = 394038.7088 g/m³; 851166.3786 kg/y; 116.5981 g/cap.day
 COD biosol= 105.1829 g/m³; 227.2066 kg/y; 0.031124 g/cap.day
 COD insol = 29.9882 g/m³; 64.7778 kg/y; 0.0088737 g/cap.day
 COD biopart = 260257.6308 g/m³; 562184.73 kg/y; 77.0116 g/cap.day
 COD inpart = 133645.9068 g/m³; 288689.6642 kg/y; 39.5465 g/cap.day
 Sum of COD-fractions = 851166.3786 kg/y

Volatile solids (VS) = 216730.236 g/m³; 468160.8329 kg/y; 64.1316 g/cap.day
 Suspended solids (TSS) = 299228.8655 g/m³; 646366.8267 kg/y; 88.5434 g/cap.day
 Dissolved solids (TS-TSS) = 771.1345 g/m³; 1665.7343 kg/y; 0.22818 g/cap.day
 Fixed solids (TS-VS) = 83269.764 g/m³; 179871.7281 kg/y; 24.64 g/cap.day
 Total solids (TS) = 300000 g/m³; 648032.561 kg/y; 88.7716 g/cap.day
 H2O = 1512075.9756 kg/y; 0.20713 kg/cap.day
 Total volume = 2160.1085 m³/y; 5.9181 m³/day
 VS content = 21.673 %
 TSS content = 29.9229 %
 TS content = 30 %

Total nitrogen = 19656.9675 g/m³; 42461.1833 kg/y; 5.8166 g/cap.day
 N-NH₃ & N-NH₄ = 51.9826 g/m³; 112.288 kg/y; 0.015382 g/cap.day
 N-NO₃ = 0.072298 g/m³; 0.15617 kg/y; 2.1393e-05 g/cap.day
 N-N₂O = 0 g/m³; 0 kg/y; 0 g/cap.day
 N-org,part = 19579.7037 g/m³; 42294.285 kg/y; 5.7937 g/cap.day
 N-org,sol = 25.209 g/m³; 54.4541 kg/y; 0.0074595 g/cap.day
 Sum of N-fractions = 42461.1833 kg/y
 N content per TSS (N-org,part/TSS) = 6.5434 %
 N content per TS (Total N/TS) = 6.5523 %

Total sulphur = 875.5612 g/m³; 1891.3073 kg/y; 0.25908 g/cap.day
 SO₄-S = 2.6534 g/m³; 5.7315 kg/y; 0.00078514 g/cap.day
 S particulate = 871.5812 g/m³; 1882.71 kg/y; 0.25791 g/cap.day
 Sulfide HS-S = 1.3267 g/m³; 2.8658 kg/y; 0.00039257 g/cap.day
 Sum of S-fractions = 1891.3073 kg/y
 S content per TSS (S particulate/TSS) = 0.29128 %
 S content per TS (Total S/TS) = 0.29185 %

Total phosphorus = 7097.5339 g/m³; 15331.4435 kg/y; 2.1002 g/cap.day
 PO₄-P = 0.7497 g/m³; 1.6194 kg/y; 0.00022184 g/cap.day
 P particulate = 7096.7842 g/m³; 15329.8241 kg/y; 2.1 g/cap.day
 Sum of P-fractions = 15331.4435 kg/y
 P content per TSS (P particulate/TSS) = 2.3717 %
 P content per TS (Total P/TS) = 2.3658 %

Total potassium = 668.9257 g/m³; 1444.9521 kg/y; 0.19794 g/cap.day
 Dissolved potassium = 18.8021 g/m³; 40.6146 kg/y; 0.0055636 g/cap.day
 Organically bound potassium = 650.1236 g/m³; 1404.3375 kg/y; 0.19237 g/cap.day
 K content per TSS (Organically bound K/TSS) = 0.21727 %
 K content per TS (Total K/TS) = 0.22298 %
 Temperature in water = 20 degC

Extra output variables

Added organic polymers = 3451.2 kg/y; 0.473 g/cap.day
 Amount of energy used = 89.75 GJ/y = 24930 kWh/y; 3.42 Wh/cap.day

The above amount of energy is equivalent to 38.5 kWh/ton TS in the dewatered sludge.

In order to demonstrate that the behaviour of the dewatering model is reasonable, a comparative simulation is done with the general wastewater treatment plant simulator GPS-X (Hydromantis, 1999). The GPS-X model is simulated according to Figure 4.1, including addition of polymers using the default parameter set of GPS-X. The GPS-X model is an empirical dynamic model. The influent wastewater is characterised similar to the URWARE input (although not as many variables are used in GPS-X). The three calibration parameters of the GPS-X model are only slightly adjusted to get results similar to the URWARE simulation. These parameters are: % of sludge easy to treat at optimal polymer dosage, % of sludge hard to treat at optimal polymer dosage and % of sludge hard to treat with no polymer dosage. No physical design parameters are available for the empirical model. Based on these simple modifications we can see that the results are similar to the URWARE results. It would be possible to come even closer with more elaborate calibration but it is certainly encouraging to see that the GPS-X model performs so similar to URWARE without any major changes for the steady-state behaviour. Note that the addition of polymers in GPS-X does not add to the TSS, COD or any other variables.

Influent wastewater (from GPS-X, URWARE inputs within parenthesis)

BOD7 = 23151 g/m3 (22935)
 COD total = 51735 g/m3 (51735)
 COD biosol= 105.2 g/m3 (105.2)
 COD insol = 30 g/m3 (30)
 COD biopart = 34294 g/m3 (34294)
 COD inpart = 17306 g/m3 (17306)

Volatile suspended solids (VSS) = 27868 g/m3 (not available in URWARE but a backwards calculation yields 33259 g/m3)
 Suspended solids (TSS) = 39250 g/m3 (39229)
 Flow rate = 47.277 m3/d (47.277)
 VSS content = 2.787 % (not available in URWARE but about 3.32%)
 TSS content = 3.925 % (3.923)

Total nitrogen = 2657 g/m3 (2657)
 N-NH3 & N-NH4 = 52 g/m3 (52)
 N-NO3 = 0.07 g/m3 (0.07)
 N-org,part = 2580 g/m3 (2580)
 N-org,sol = 25.2 g/m3 (25.2)

Effluent wastewater (from GPS-X, URWARE results within parenthesis)

BOD7 = 1224.8 g/m3 (1377)
 COD total = 2715.2 g/m3 (3101)
 COD biosol= 105.2 g/m3 (105.2)
 COD insol = 30 g/m3 (30)
 COD biopart = 1714.7 g/m3 (1960)
 COD inpart = 865.3 g/m3 (1006)

Volatile suspended solids (VSS) = 1393.4 g/m3 (not available in URWARE but about 1910 g/m3)

The URWARE Wastewater Treatment Plant Models

Suspended solids (TSS) = 1962.5 g/m³ (2253)
Flow rate (effluent) = 41.44 m³/d (41.4)
VSS content = 0.1393 % (not available in URWARE but 0.19%)
TSS content = 0.1962 % (0.2253)

Total nitrogen = 206.3 g/m³ (225)
N-NH₃ & N-NH₄ = 52 g/m³ (52)
N-NO₃ = 0.07 g/m³ (0.07)
N-org,part = 129 g/m³ (147)
N-org,sol = 25.22 g/m³ (25.2)

Sludge stream (from GPS-X, URWARE results within parenthesis)

BOD₇ = 178830 g/m³ (173595)
COD total = 399785 g/m³ (394038)
COD biosol = 105.2 g/m³ (105.2)
COD insol = 30 g/m³ (30)
COD biopart = 265610 g/m³ (260258)
COD inpart = 134040 g/m³ (133646)

Volatile suspended solids (VSS) = 215840 g/m³ (not available in URWARE but about 256389 g/m³)
Suspended solids (TSS) = 304000 g/m³ (300000)
Flow rate (underflow) = 5.84 m³/d (5.92)
VSS content = 21.6 % (not available in URWARE but about 25.6%)
TSS content = 30.4 % (30)

Total nitrogen = 20060 g/m³ (19657)
N-NH₃ & N-NH₄ = 52 g/m³ (52)
N-NO₃ = 0.07 g/m³ (0.07)
N-org,part = 19982 g/m³ (19580)
N-org,sol = 25.22 g/m³ (25.2)

Added organic polymers = 9.46 kg/d (9.46)

5

Sand filtration

The sand filtration model describes the principle behaviour of a multi-media sand filtration unit used for final polishing. At this stage the unit performs separation of suspended solids and allows for chemical precipitation to remove excess phosphate (same principle as used for the primary and final sedimentation units). Real sand filters may also demonstrate significant biological activity (COD removal, nitrification and possibly denitrification) but this has not yet been included. Consequently, the model is referred to as a phosphorus and TSS polishing sand filter with a short retention time and not as a sand filter used for actual biological treatment. This will maybe be a future extension. The model may be operated in two different modes (defined by the user): either a simple sand filtration unit (mode 0) or as a sand filtration unit combined with a sedimentation unit (mode 1). The principle of the two different modes and their respective system borders are shown in Figure 5.1. The code describing the sandfilter model is given in Appendix M.

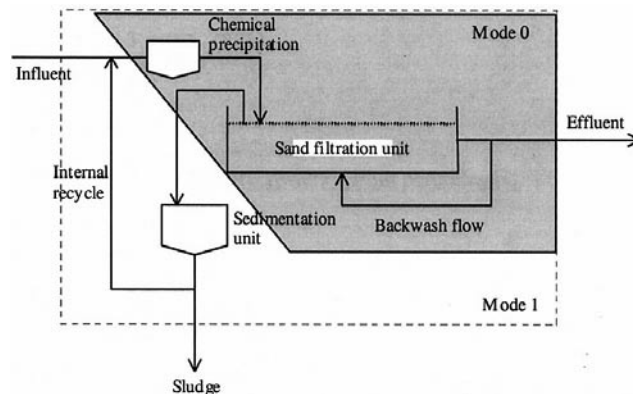

Figure 5.1
General flow scheme for
the sand filtration model
(modes 0 and 1).

The behaviour of the sand filtration model is influenced by twelve user-defined parameters, which are defined in the initialisation file `spInit.m`. These are:

- **spFiltSludgeTSPerc**: defines the total solids content (TS) of the sludge stream (%). Suggested value is 3-4% (Hellström, 2004). This parameter is only active in mode 1, i.e. when sedimentation is included.

- **spFiltSSOut**: defines the concentration of total suspended solids (TSS) in the effluent from the sand filter. Suggested value is 2 mg TSS/l (Hellström, 2004). The model can easily be modified to instead base the effluent TSS concentration on a defined fraction of the influent TSS concentration.
- **spFiltFeCl3In**: defines the concentration of added precipitation chemicals, i.e. kg FeCl₃ per kg solution (chemical + water). Suggested value 0.2.
- **spFiltPO4Out**: defines the requested effluent concentration of PO₄-P. If the value is higher than the influent concentration the model adjusts the value to equal the influent concentration and if it is lower than the influent concentration then the chemical precipitation part of the model is activated. Suggested value when using chemical precipitation is 0.05-0.1 mg PO₄-P/l. Note the previous discussion on phosphate and other dissolved organic phosphorus content.
- **spCODtoVS(1,1)**: conversion factor for calculating volatile solids (VS) from biodegradable COD fractions. Suggested value $1/1.42 \approx 0.704$ (Metcalf & Eddy, 1991).
- **spCODtoVS(2,1)**: conversion factor for calculating volatile solids (VS) from non-biodegradable COD fractions. Suggested value $1/1.9 \approx 0.526$.
- **spFiltMode**: operational mode of the model (mode 0 = only sand filter; mode 1 = sand filter combined with sedimentation).
- **spFiltBackwash**: sets the % of the input flow used for backwashing of the filter. It is assumed that the effluent water is used for backwashing. Suggested value is 5%. This parameter is only active in mode 0. In mode 1 a backwash flow of 5% is assumed within the model but it only affects the pumping energy requirements.
- **spFiltEnergy(1,1)**: defines the energy required for mixing when precipitation is active. Suggested value 5400 J/m³ of influent flow (= 1.5 Wh/m³).
- **spFiltEnergy(2,1)**: defines the energy required for sludge scrapers (only active in mode 1). Suggested value 5400 J/m³ of influent flow (= 1.5 Wh/m³).
- **spFiltEnergy(3,1)**: defines the energy required for pumping water from the settler to the sandfilter in mode 1. Suggested value 180000 J/m³ of pumped flow (= 50 Wh/m³).
- **spFiltEnergy(4,1)**: defines the energy required for pumping and pressure loss in the actual sand filter. Active in both modes. Suggested value 36000 J/m³ of influent flow (= 10 Wh/m³) (Balmér, personal communication).

The above twelve parameters are gathered into a vector (spFiltPAR) and included as an argument when calling the actual sand filtration model (spFiltModel.m). Consequently, the user has easy access to all model parameters in a specific text file and new parameters can easily be added when the need arise, thus promoting the future flexibility of the program.

A special global parameter – **spFiltInputVolume** – is also used. This is necessary when operating the filter in mode 0. The filter washout (underflow) is then likely to be recycled to previous parts of the plant and will consequently add to the input. In this case the backwash flow is assumed to be **spFiltBackwash** % of the input flow volume but as different recycle streams may be used, a definition in terms of % of the input flow would create a positive feed-back loop and lead to an unstable system (i.e. as the simulation is running forward in time the input would increase towards infinity if a part of the output defined as a certain percent of the on-line determined input flow is recycled back to the input). To avoid this the backwash flow is defined as **spFiltBackwash** % of the input flow to the sandfilter at the start of the simulation, i.e. while no feed-back loops are active (all feed back is initially set to zero). **spFiltInputVolume** is initialised in `spInit.m` to an unreasonable large value and is then set to the actual input value at the first simulation step. If the actual input volume is larger than **spFiltInputVolume** during the course of the simulation the value set at the first simulation step is used. By this approach, numerical instability is avoided.

Due to the fact that the chemical precipitation is internal within the model (when activated) and the added chemicals not a traditional input variable, we first need to make the calculations related to this process. The reason for this is that it will have an effect on the TS, TSS and water content (as well as future impact on Fe and Cl concentrations), which in turn will influence the filtration process. We are assuming that FeCl_3 is used for precipitation (only simple mass conversions are required if another 3^+ ion is used, i.e. Al^{3+}). The following reactions take place:

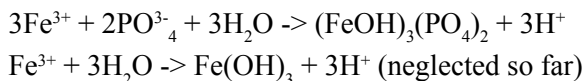

Consequently, an absolute minimum of 1.5 mol of Fe^{3+} is required to remove 1 mol of P (if the last reaction is neglected). This means that 7.86 g FeCl_3 must be added for every g of P removed and that 6.594 g $(\text{FeOH})_3(\text{PO}_4)_2$ is formed for every g of P removed. The phosphate is transformed into particulate P, the amount of TS increases by the amount of added FeCl_3 , the water content increases due to the water phase of the added FeCl_3 solution and the TSS increases by the amount of formed $(\text{FeOH})_3(\text{PO}_4)_2$. The user affects this part of the model by adjusting the parameters **spFiltFeCl3In** and **spFiltPO4Out**. In case **spFiltPO4Out** is set higher or equivalent to the influent PO_4 concentration then no adjustments are made and the influent into the settler is the same as the original input into the module. Other more detailed changes to the behaviour of the filtration process due to chemical precipitation are currently neglected. The transformations are summarised in Table 5.1. It must be noted that before the new values of elements 8, 22, 42, 79 and 80 are calculated, the entire original input vector has been transformed into mass units by the function `conc2load`, whereas `PO4_in` (when calculating the help variable 'removedPO4') represent the concentration. Once the new values of the five variables have been calculated, the function `load2conc` is used to transform the entire vector into concentrations again and thereby taking into account the new values for TS and H_2O

caused by the added precipitation chemicals (which will slightly affect all variables in the vector on a concentration basis).

Position. Variable	Relationship	Comment
8. TS	TS_in + addedFeCl3	
22. H2O	H2O_in + addedH2O	extra H2O in FeCl3 solution
42. TSS	TSS_in + createdFeOH3PO42	
79. PO4	spFiltPO4Out*flow_in	PO4 not exactly = spFiltPO4Out
80. P_part	P_part_in + removedPO4	
Help variables		
flow_in = H2O_in + TS_in		mass (= volume)
removedPO4 = (PO4_in - spFiltPO4Out) * flow_in		mass = conc * volume
addedFeCl3 = 7.86 * removedPO4		mass
addedH2O = addedFeCl3 * (1 - spFiltFeCl3In) / spFiltFeCl3In		mass (= volume)
createdFeOH3PO42 = 6.594 * removedPO4		mass

Table 5.
Description of the chemical precipitation processes.

Once the internal modifications of the variables in the vector affected by the precipitation have been made, it is possible to model the actual filtration process. The principle is slightly different compared to the earlier description for the sedimentation and dewatering processes. In this case the user explicitly defines the effluent TSS concentration in the filter effluent (rather than defining the removal percentage of influent TSS) by the parameter **spFiltSSOut**. The reason for this is based on discussions within the URWARE research group. However, the model can easily be adjusted to work in accordance with the principle used by the previously discussed models. In mode 0 (only sand filter) the parameter **spFiltBackwash** defines the flow volume of the filter underflow (or backwash). We make a simplification here and state that the defined flow volume includes the volume of the suspended material within the filter that will be released during the normally intermittent backwash procedure (as we are only modelling the steady state behaviour of the process, i.e. a slightly smaller volume than 5% is actually withdrawn from the effluent). Based on these two parameters, the fundamental behaviour of the filtration unit in mode 0 is defined. We assume that $TS_{dissolved} = TS - TSS$. The fundamental equation is based on a mass balance over the filtration process. In terms of TS, this means:

$$TS_{in} = TS_{effluent} + TS_{sludge}$$

$$H2O_{in} = H2O_{effluent} + H2O_{sludge}$$

$$totalflow_{in} = totalflow_{effluent} + totalflow_{sludge}$$

where TS_{in} , $H2O_{in}$ and $totalflow_{in}$ ($= TS_{in} + H2O_{in}$) are the adjusted variables after the precipitation addition (mass unit). We also know that

$$totalflow_{sludge} = spFiltInputVolume * spFiltBackwash$$

$$totalflow_{effluent} = totalflow_{in} - totalflow_{sludge}$$

Since we now know the $totalflow_{effluent}$ we can calculate the $TS_{flow_{effluent}}$ as we have defined what the effluent TSS concentration should

be (we assume that $TS_{dissolved}$ is the same in all streams, which is a necessary simplification discussed in Chapters 2 and 4). Then the remaining flows are easily determined:

$$TS_{flow_effluent} = (TS_{in}/total_{flow_in} - 10^{-6} * (TSS_{in} + spFiltSSOut)) * total_{flow_effluent}$$

where $TS_{flow_effluent}$ has the unit $kg = dm^3$

$$H2O_{flow_effluent} = total_{flow_effluent} - TS_{flow_effluent}$$

$$H2O_{flow_sludge} = H2O_{flow_in} - H2O_{flow_effluent}$$

$$TS_{flow_sludge} = total_{flow_sludge} - H2O_{flow_sludge}$$

Based on the above we can now summarise the expressions for calculating the different flow streams out from the filtration process. This is shown in Table 5.2. Note that all in-variables have already been adjusted for the effects caused by the precipitation addition.

Help variable	Relationship	Comment
totalflow_in	= H2O_in + TS_in	Adjusted for precipitation addition
totalflow_sludge	= spFiltInputVolume * spFiltBackwash	spFiltInputVolume global variable defined at first simulation step
H2Oflow_sludge	= H2Oflow_in - H2Oflow_effluent	
TSflow_sludge	= totalflow_sludge - H2Oflow_sludge	
totalflow_effluent	= totalflow_in - totalflow_sludge	
TSflow_effluent	= (TS_in/totalflow_in - 10e-6 * (TSS_in + spFiltSSOut)) * totalflow_effluent	TSS_in as concentration (mg/l) All mass units in kg
H2Oflow_effluent	= totalflow_effluent - TSflow_effluent	

Table 5.2
Calculating the different flows (water phase and total) in mode 0.

When operating the sand filter in mode 1 (i.e. the sand filter and a sedimentation unit together as one process) the situation is somewhat different. In this case, the amount of backwash is not relevant since the volume of the sludge flow will be determined by the user defined parameter **spFiltSludgeTSPerc**. The majority of the flow used for backwashing will be recycled to the sand filter as effluent water from the sedimentation (done internally in the model without any transparency for the user) and therefore we can only assume that backwashing is sufficiently good to maintain the concentration of TSS in the sand filter effluent as defined by the user parameter **spFiltSSOut**. It should be noted that a backwash flow of 5% is assumed in the model for mode 1 in order to calculate the appropriate energy requirements for pumping. However, as a start we can take advantage of the fundamental equations we determined for the sedimentation and dewatering process (i.e. when the TSS reduction was defined rather than the effluent TSS concentration, see Chapters 2 and 4). For the sand filter (including sedimentation) this would imply:

$$total_{flow_sludge} = (spFiltRed * TSS_{in} * total_{flow_in}) / (10^6 * (spFiltSludgeTSPerc - TS_{in} / total_{flow_in}) - TSS_{in})$$

We do not know the value of **spFiltRed** but we can define an equation for

it using the parameter **spFiltSSOut**:

$$\text{spFiltRed} = 1 - (\text{spFiltSSOut} * \text{totalflow_effluent} / (\text{TSS_in} * \text{totalflow_in})) = ((\text{TSS_in} - \text{spFiltSSOut}) * \text{totalflow_in} + \text{spFiltSSOut} * \text{totalflow_sludge}) / (\text{TSS_in} * \text{totalflow_in})$$

If we exchange **spFiltRed** in the fundamental equation with the expression above, we get an equation that we can analytically simplify. After some calculations we end up with:

$$\text{totalflow_sludge} = (\text{TSS_in} - \text{spFiltSSOut}) * \text{totalflow_in} / (10^6 * (\text{spFiltSludgeTSPerc} - \text{TS_in} / \text{totalflow_in}) - \text{TSS_in} - \text{spFiltSSOut})$$

note: **spFiltSludgeTSPerc** * 10⁶ = TS_sludge in mg/dm³ (since we assume 1 kg = 1 dm³)

$$\text{kg/kg} = \text{kg/dm}^3 = 10^6 \text{ mg/dm}^3$$

The remaining flows can now easily be defined and the results are shown in Table 5.3.

Help variable	Relationship	Comment
totalflow_in	= H2O_in + TS_in	Adjusted for FeCl3 addition
totalflow_sludge	= (TSS_in - spFiltSSOut)*totalflow_in / (10e6 * (spFiltSludgeTSPerc - TS_in/totalflow_in) - TSS_in - spFiltSSOut)	TSS_in as concentration (mg / (mg/kg))
H2Oflow_sludge	= totalflow_sludge * (1 - spFiltSludgeTSPerc)	
TSflow_sludge	= totalflow_sludge - H2Oflow_sludge	
totalflow_effluent	= totalflow_in - totalflow_sludge	
TSflow_effluent	= TS_in - TSflow_sludge	
H2Oflow_effluent	= totalflow_effluent - TSflow_effluent	

Table 5.3
Calculating the different flows (water phase and total) in mode 1.

Once these fundamental expressions have been defined we can calculate the behaviour for the other priority variables in the URWARE vector. At this stage the behaviour is simply a matter of whether a variable is dissolved (in which case the influent concentration is equivalent to the output concentration) or particulate (in which case the variable will behave in the same way as the TSS variable). However, the particulate phosphorus formed by precipitation is assumed to be completely removed and is included in the sludge stream. The reason for this was discussed in detail in Chapter 2. However, it should be noted that it is only the newly formed precipitated P that is completely removed. The remaining particulate phosphorus, which is organically bound as the wastewater enters the sand filter, is removed proportionally to the TSS. VS is calculated based on the defined conversion parameters whereas BOD in the output streams is proportional to the BOD: COD_biodegradable ratio in the influent and the same ratio is assumed in the two output streams. This is a reasonable assumption as biological activity in the settler is neglected. In Table 5.4 the calculations are shown for all variables in the effluent flow stream. Notably, these descriptions are independent of whether the filter is operated in mode 0 or 1. We can use the previously defined help variable

$$\text{spFiltRed} = 1 - (\text{spFiltSSOut} * \text{totalflow_effluent} / (\text{TSS_in} * \text{totalflow_in}))$$

which is equivalent to the parameter defining the percentage of TSS reduction used in the sedimentation and dewatering processes and use the same relationships to define the filtration unit.

Position. variable name	Relationship	Comment
6. BOD	$= \text{in}(6) * (\text{out}(75) + \text{out}(77)) / (\text{in}(75) + \text{in}(77))$	Calculated once effluent variables 75 and 77 are known
7. Volatile solids (VS)	$= \text{spCODtoVS}(1,1) * (\text{out}(75) + \text{out}(77)) + \text{spCODtoVS}(2,1) * (\text{out}(76) + \text{out}(78))$	Calculated once effluent variables 75, 76, 77 and 78 are known
8. Total solids (TS)	$= \text{TSflow_effluent}$	See Tables 4.2 and 4.3, mass unit
22. Water	$= \text{H2Oflow_effluent}$	See Tables 4.2 and 4.3, mass unit
23. Total nitrogen (N-tot)	$= \text{out}(24) + \text{out}(26) + \text{out}(44) + \text{out}(81)$	Calculated once effluent variables 24, 26, 44 and 81 are known
24. Ammonia/ammonium	$= \text{in}(24)$	$\text{NH4_out} = \text{NH4_in}$
26. Nitrate/nitrite	$= \text{in}(26)$	$\text{NO3_out} = \text{NO3_in}$
28. Total sulphur (S-tot)	$= \text{out}(29) + \text{out}(46)$	Calculated once effluent variables 29 and 46 are known
29. Sulphate	$= \text{in}(29)$	$\text{SO4_out} = \text{SO4_in}$
30. Total phosphorus (P-tot)	$= \text{out}(79) + \text{out}(80)$	Calculated once effluent variables 79 and 80 are known
32. Total potassium (K-tot)	$= \text{in}(32)$	$\text{K_out} = \text{K_in}$
42. Suspended solids (TSS)	$= \text{in}(42) * \text{totalflow_in} * (1 - \text{spFiltRed}) / \text{totalflow_effluent}$	
43. Total COD	$= (\text{in}(43) * \text{totalflow_in} - (\text{in}(75) + \text{in}(76)) * \text{totalflow_sludge} - \text{spFiltRed} * (\text{in}(77) + \text{in}(78)) * \text{totalflow_in}) / \text{totalflow_effluent}$	Equivalent to $\text{out}(75) + \text{out}(76) + \text{out}(77) + \text{out}(78)$
44. Soluble organic nitrogen	$= \text{in}(44)$	$\text{Norg,sol_out} = \text{Norg,sol_in}$
46. Particulate sulphur	$= \text{in}(46) * \text{totalflow_in} * (1 - \text{spFiltRed}) / \text{totalflow_effluent}$	Equivalent to TSS
48. Sulfide (HS-S)	$= \text{in}(48)$	
49. Organically bound potassium	$= \text{in}(49) * \text{totalflow_in} * (1 - \text{spFiltRed}) / \text{totalflow_effluent}$	Equivalent to TSS
75. COD, soluble&biodreg	$= \text{in}(75)$	$\text{CODsol,bio_out} = \text{CODsol,bio_in}$
76. COD, soluble&inert	$= \text{in}(76)$	$\text{CODsol,inert_out} = \text{CODsol,inert_in}$
77. COD, part&biodreg	$= \text{in}(77) * \text{totalflow_in} * (1 - \text{spFiltRed}) / \text{totalflow_effluent}$	Equivalent to TSS
78. COD, part&inert	$= \text{in}(78) * \text{totalflow_in} * (1 - \text{spFiltRed}) / \text{totalflow_effluent}$	Equivalent to TSS
79. Phosphate	$= \text{in}(79)$	$\text{PO4_out} = \text{PO4_in}$
80. Phosphorus, particulate	$= (\text{in}(80) * \text{totalflow_in} - \text{removed-PO4}) * (1 - \text{spFiltRed}) / \text{totalflow_effluent}$	Precipitated P removed 100% and the remaining P_part is handled equivalent to TSS
81. Nitrogen, org&particulate	$= \text{in}(81) * \text{totalflow_in} * (1 - \text{spFiltRed}) / \text{totalflow_effluent}$	Equivalent to TSS
82. Temperature	$= \text{in}(82)$	

Table 5.4
Calculating the variables in the effluent stream.

When all the variables in the effluent vector have been calculated the easiest (and safest) way to determine the variables in the sludge vector is to use the explicit mass balance. This means that for each variable in the sludge output the following calculation is carried out:

sludge variable =

$$(\text{influent variable} * \text{totalflow_in} - \text{effluent variable} * \text{totalflow_effluent}) / \text{totalflow_sludge}$$

Finally, six extra variables are given in the output vector:

- addedFeCl3;
- total energy use;
- energy for mixing of precipitation chemicals;
- energy for sludge scrapers (only mode 1);
- energy for pumping between sand filter and settler (only mode 1);
- energy for pumping and pressure loss in the sand filter itself.

The calculation of addedFeCl3 was described in Table 5.1.

The energy usage is divided into four sub-categories and based on several assumptions (see also Chapter 9). Energy use is normally calculated in relation to flow so that the energy use automatically adjusts to plants of different sizes and different layouts of the same plant. If chemical precipitation is active then an energy use related to this process is included (e.g. for mixing), which is defined by the parameter **spFiltEnergy(1,1)** and the suggested value is 1.5 Wh per m³ of influent flow to the unit (5400 J/m³). For the general energy consumption by the sandfilter itself it is assumed that 10 Wh per m³ of influent flow to the unit (36000 J/m³) is required. This is defined by is defined by the parameter **spFiltEnergy(4,1)**. This part is active in both mode 0 and 1 and includes energy for pumping in the sandfilter and the pressure loss over the filter. In mode 1, the energy required by the sedimentation unit must be added, both for operating the sludge scrapers and and pumping the effluent back to the sandfilter and the sludge out of the settler. As the exact flow from the sandfilter to the sedimentation unit is not defined in mode 1, we assume that 5% of the influent flow is used for backwashing and must be pumped. The energy for sludge scrapers is set to 1.5 Wh per m³ of influent flow to the unit (5400 J/m³) and energy for pumping is set to 50 Wh/m³ of the backwash flow (180000 J/m³). The values are defined by the parameters **spFiltEnergy(2,1)** and **spFiltEnergy(3,1)**, respectively. The different energy categories are then added together and given also as a total energy output variable from the model. The details are given in the pseudo-code below. Many readers may feel more comfortable using energy consumption per filter cycle or similar. However, as URWARE is based on yearly averages such detailed dynamics are not included in the models.

```

if chemical precipitation is active
    sludgemixenergy = spFiltEnergy(1,1)*(totalflow_in)/1000; %J/year
else
    sludgemixenergy = 0;
end
filterenergy = spFiltEnergy(4,1)*totalflow_in/1000; %J/year
if operating mode = 1 (sand filter + settler)
    pumpingenergy = spFiltEnergy(3,1)*0.05*totalflow_in/1000; % J/year (5% of flow)
    sludgeremenergy = spFiltEnergy(2,1)*0.05*totalflow_in/1000; % J/year
end
energy = sludgemixenergy + filterenergy + pumpingenergy + sludgeremenergy;

```

In order to account for the different energy efficiencies for small and large plants a special function is used by which all energy values are multiplied in all models. The shape of this function is defined by the user and simply represents the fact that the energy requirements for a small plant is normally

higher than that of a large plant per m³ of treated wastewater since large electrical drives are normally more efficient than small ones. The energy adjustment function is further discussed in Chapter 9. The values suggested for the four spFiltEnergy parameters represent the situation at a large and energy-efficient WWTP.

A few open questions that may need to be considered in the future for the filtration process are:

- Biological COD removal in the filter?
- Biological nitrification in the filter?
- Biological denitrification in the filter?
- Phosphorus release in the filter?
- Addition of other chemicals?
- Make **spFiltBackwash** a function of removed TSS in the filter?

To demonstrate the general behaviour of the model, three simulation cases are presented below. The contents of the influent wastewater to the sand filter are in all cases identical to the contents of the effluent stream for simulation Case 2.2 in Section 2.1 – Primary sedimentation with active chemical precipitation. Consequently this is a case of sand filtration of a wastewater which has not been treated biologically (only physically and to some extent chemically) with a content of COD and N much higher than would normally be loaded to a polishing sand filter. However, the principle behaviour can still be demonstrated. Note that the energy adjustment function is not activated in the cases shown below.

Case 5.1: Sand filtration with active chemical precipitation but without sedimentation (mode 0)

Model parameters: **spFiltSludgeTSPerc** = 0.04 (4%) – not in use in mode 0
spFiltSSOut = 2 mg TSS/l
spFiltFeCl3In = 0.2 (g FeCl3/g solution)
spFiltPO4Out = 0.1 mg PO4-P/l (i.e. < PO4-P in, active precip.)
spCODtoVS(1,1) = 1/1.42 (g VS/g COD_biodegradable)
spCODtoVS(2,1) = 1/1.9 (g VS/g COD_inert)
spFiltMode = 0 (i.e. only sand filtration unit)
spFiltBackwash = 0.05 (5% of original input volume)
spFiltEnergy(1,1) = 5400 J/m³
spFiltEnergy(2,1) = 5400 J/m³
spFiltEnergy(3,1) = 180000 J/m³
spFiltEnergy(4,1) = 36000 J/m³

Influent wastewater

BOD7 = 96.8397 g/m³; 159029.9929 kg/y; 21.7849 g/cap.day
COD total = 195.4434 g/m³; 320956.8057 kg/y; 43.9667 g/cap.day
COD biosol = 105.204 g/m³; 172765.7888 kg/y; 23.6665 g/cap.day
COD insol = 29.9942 g/m³; 49256.4169 kg/y; 6.7475 g/cap.day
COD biopart = 40.0394 g/m³; 65752.6 kg/y; 9.0072 g/cap.day
COD inpart = 20.2058 g/m³; 33182 kg/y; 4.5455 g/cap.day

The URWARE Wastewater Treatment Plant Models

Sum of COD-fractions = 320956.8057 kg/y

Volatile solids (VS) = 128.7051 g/m³; 211359.3368 kg/y; 28.9533 g/cap.day
Suspended solids (TSS) = 45.8014 g/m³; 75214.9902 kg/y; 10.3034 g/cap.day
Dissolved solids (TS-TSS) = 771.2888 g/m³; 1266609.1188 kg/y; 173.5081 g/cap.day
Fixed solids (TS-VS) = 688.385 g/m³; 1130464.7722 kg/y; 154.8582 g/cap.day
Total solids (TS) = 817.0902 g/m³; 1341824.109 kg/y; 183.8115 g/cap.day
H₂O = 1640856509.3477 kg/y; 224.7749 kg/cap.day
Total volume = 1642198.3335 m³/y; 4499.1735 m³/day
VS content = 0.012871 %
TSS content = 0.0045801 %
TS content = 0.081709 %

Total nitrogen = 80.2915 g/m³; 131854.636 kg/y; 18.0623 g/cap.day
N-NH₃ & N-NH₄ = 51.993 g/m³; 85382.8033 kg/y; 11.6963 g/cap.day
N-NO₃ = 0.072313 g/m³; 118.7522 kg/y; 0.016267 g/cap.day
N-N₂O = 0 g/m³; 0 kg/y; 0 g/cap.day
N-org,part = 3.0122 g/m³; 4946.7 kg/y; 0.67763 g/cap.day
N-org,sol = 25.214 g/m³; 41406.3806 kg/y; 5.6721 g/cap.day
Sum of N-fractions = 131854.636 kg/y
N content per TSS (N-org,part/TSS) = 6.5767 %
N content per TS (Total N/TS) = 9.8265 %

Total sulphur = 4.1149 g/m³; 6757.5064 kg/y; 0.92569 g/cap.day
SO₄-S = 2.6539 g/m³; 4358.2043 kg/y; 0.59701 g/cap.day
S particulate = 0.13409 g/m³; 220.2 kg/y; 0.030164 g/cap.day
Sulfide HS-S = 1.3269 g/m³; 2179.1021 kg/y; 0.29851 g/cap.day
Sum of S-fractions = 6757.5064 kg/y
S content per TSS (S particulate/TSS) = 0.29276 %
S content per TS (Total S/TS) = 0.50361 %

Total phosphorus = 1.2729 g/m³; 2090.4036 kg/y; 0.28636 g/cap.day
PO₄-P = 0.74985 g/m³; 1231.4036 kg/y; 0.16869 g/cap.day
P particulate = 0.52308 g/m³; 859 kg/y; 0.11767 g/cap.day
Sum of P-fractions = 2090.4036 kg/y
P content per TSS (P particulate/TSS) = 1.1421 %
P content per TS (Total P/TS) = 0.15579 %

Total potassium = 18.9059 g/m³; 31047.2337 kg/y; 4.253 g/cap.day
Dissolved potassium = 18.8059 g/m³; 30882.9837 kg/y; 4.2305 g/cap.day
Organically bound potassium = 0.10002 g/m³; 164.25 kg/y; 0.0225 g/cap.day
K content per TSS (Organically bound K/TSS) = 0.21837 %
K content per TS (Total K/TS) = 2.3138 %
Temperature in water = 20 degC

Effluent wastewater

BOD₇ = 71.208 g/m³; 111093.7681 kg/y; 15.2183 g/cap.day
COD total = 137.6004 g/m³; 214674.5004 kg/y; 29.4075 g/cap.day
COD biosol = 105.2013 g/m³; 164127.72 kg/y; 22.4832 g/cap.day
COD insol = 29.9934 g/m³; 46793.659 kg/y; 6.4101 g/cap.day
COD biopart = 1.5988 g/m³; 2494.3497 kg/y; 0.34169 g/cap.day
COD inpart = 0.80684 g/m³; 1258.7717 kg/y; 0.17243 g/cap.day
Sum of COD-fractions = 214674.5004 kg/y

Volatile solids (VS) = 91.422 g/m³; 142630.2387 kg/y; 19.5384 g/cap.day
Suspended solids (TSS) = 2 g/m³; 3120.2607 kg/y; 0.42743 g/cap.day
Dissolved solids (TS-TSS) = 772.0918 g/m³; 1204563.7839 kg/y; 165.0087 g/cap.day
Fixed solids (TS-VS) = 682.6698 g/m³; 1065053.8059 kg/y; 145.8978 g/cap.day

The URWARE Wastewater Treatment Plant Models

Total solids (TS) = 774.0918 g/m³; 1207684.0446 kg/y; 165.4362 g/cap.day
H₂O = 1558922673.0601 kg/y; 213.5511 kg/cap.day
Total volume = 1560130.3571 m³/y; 4274.3297 m³/day
VS content = 0.0091422 %
TSS content = 0.0002 %
TS content = 0.077409 %

Total nitrogen = 77.3976 g/m³; 120750.3562 kg/y; 16.5411 g/cap.day
N-NH₃ & N-NH₄ = 51.9917 g/m³; 81113.7721 kg/y; 11.1115 g/cap.day
N-NO₃ = 0.072311 g/m³; 112.8147 kg/y; 0.015454 g/cap.day
N-N₂O = 0 g/m³; 0 kg/y; 0 g/cap.day
N-org,part = 0.12028 g/m³; 187.6549 kg/y; 0.025706 g/cap.day
N-org,sol = 25.2134 g/m³; 39336.1144 kg/y; 5.3885 g/cap.day
Sum of N-fractions = 120750.3562 kg/y
N content per TSS (N-org,part/TSS) = 6.0141 %
N content per TS (Total N/TS) = 9.9985 %

Total sulphur = 3.9861 g/m³; 6218.8028 kg/y; 0.85189 g/cap.day
SO₄-S = 2.6538 g/m³; 4140.2996 kg/y; 0.56716 g/cap.day
S particulate = 0.0053543 g/m³; 8.3534 kg/y; 0.0011443 g/cap.day
Sulfide HS-S = 1.3269 g/m³; 2070.1498 kg/y; 0.28358 g/cap.day
Sum of S-fractions = 6218.8028 kg/y
S content per TSS (S particulate/TSS) = 0.26771 %
S content per TS (Total S/TS) = 0.51494 %

Total phosphorus = 0.12088 g/m³; 188.5955 kg/y; 0.025835 g/cap.day
PO₄-P = 0.099997 g/m³; 156.0091 kg/y; 0.021371 g/cap.day
P particulate = 0.020887 g/m³; 32.5865 kg/y; 0.0044639 g/cap.day
Sum of P-fractions = 188.5955 kg/y
P content per TSS (P particulate/TSS) = 1.0444 %
P content per TS (Total P/TS) = 0.015616 %

Total potassium = 18.8094 g/m³; 29345.1048 kg/y; 4.0199 g/cap.day
Dissolved potassium = 18.8054 g/m³; 29338.8739 kg/y; 4.019 g/cap.day
Organically bound potassium = 0.0039938 g/m³; 6.2309 kg/y; 0.00085355 g/cap.day
K content per TSS (Organically bound K/TSS) = 0.19969 %
K content per TS (Total K/TS) = 2.4299 %
Temperature in water = 20 degC

Sludge stream

BOD₇ = 583.8055 g/m³; 47936.2248 kg/y; 6.5666 g/cap.day
COD total = 1294.3906 g/m³; 106282.3053 kg/y; 14.5592 g/cap.day
COD biosol = 105.2013 g/m³; 8638.0688 kg/y; 1.1833 g/cap.day
COD insol = 29.9934 g/m³; 2462.7579 kg/y; 0.33736 g/cap.day
COD biopart = 770.4094 g/m³; 63258.2503 kg/y; 8.6655 g/cap.day
COD inpart = 388.7865 g/m³; 31923.2283 kg/y; 4.373 g/cap.day
Sum of COD-fractions = 106282.3053 kg/y

Volatile solids (VS) = 837.0377 g/m³; 68729.0981 kg/y; 9.4149 g/cap.day
Suspended solids (TSS) = 963.7294 g/m³; 79131.739 kg/y; 10.84 g/cap.day
Dissolved solids (TS-TSS) = 772.0918 g/m³; 63396.3896 kg/y; 8.6844 g/cap.day
Fixed solids (TS-VS) = 898.7834 g/m³; 73799.0305 kg/y; 10.1095 g/cap.day
Total solids (TS) = 1735.8211 g/m³; 142528.1286 kg/y; 19.5244 g/cap.day
H₂O = 81967388.5442 kg/y; 11.2284 kg/cap.day
Total volume = 82109.9167 m³/y; 224.9587 m³/day
VS content = 0.083704 %
TSS content = 0.096373 %
TS content = 0.17358 %

Total nitrogen = 135.2368 g/m³; 11104.2798 kg/y; 1.5211 g/cap.day
 N-NH₃ & N-NH₄ = 51.9917 g/m³; 4269.0311 kg/y; 0.5848 g/cap.day
 N-NO₃ = 0.072311 g/m³; 5.9375 kg/y; 0.00081335 g/cap.day
 N-N₂O = 0 g/m³; 0 kg/y; 0 g/cap.day
 N-org,part = 57.9594 g/m³; 4759.0451 kg/y; 0.65192 g/cap.day
 N-org,sol = 25.2134 g/m³; 2070.2662 kg/y; 0.2836 g/cap.day
 Sum of N-fractions = 11104.2798 kg/y
 N content per TSS (N-org,part/TSS) = 6.0141 %
 N content per TS (Total N/TS) = 7.7909 %

Total sulphur = 6.5608 g/m³; 538.7036 kg/y; 0.073795 g/cap.day
 SO₄-S = 2.6538 g/m³; 217.9046 kg/y; 0.02985 g/cap.day
 S particulate = 2.58 g/m³; 211.8466 kg/y; 0.02902 g/cap.day
 Sulfide HS-S = 1.3269 g/m³; 108.9523 kg/y; 0.014925 g/cap.day
 Sum of S-fractions = 538.7036 kg/y
 S content per TSS (S particulate/TSS) = 0.26771 %
 S content per TS (Total S/TS) = 0.37796 %

Total phosphorus = 23.1617 g/m³; 1901.808 kg/y; 0.26052 g/cap.day
 PO₄-P = 0.099997 g/m³; 8.2108 kg/y; 0.0011248 g/cap.day
 P particulate = 23.0617 g/m³; 1893.5972 kg/y; 0.2594 g/cap.day
 Sum of P-fractions = 1901.808 kg/y
 P content per TSS (P particulate/TSS) = 2.393 %
 P content per TS (Total P/TS) = 1.3343 %

Total potassium = 20.7299 g/m³; 1702.1289 kg/y; 0.23317 g/cap.day
 Dissolved potassium = 18.8054 g/m³; 1544.1097 kg/y; 0.21152 g/cap.day
 Organically bound potassium = 1.9245 g/m³; 158.0191 kg/y; 0.021646 g/cap.day
 K content per TSS (Organically bound K/TSS) = 0.19969 %
 K content per TS (Total K/TS) = 1.1942 %
 Temperature in water = 20 degC

Extra output variables

Added FeCl₃ = 8388.1 kg/y; 1.149 g/cap.day
 Amount of total energy used = 67.99 GJ/y = 18885.7 kWh/y; 2.59 Wh/cap.day
 Amount of energy used for mixing = 8.868 GJ/y = 2463.4 kWh/y; 0.337 Wh/cap.day
 Amount of energy used for sludge scrapers = 9.138 GJ/y = 2538.5 kWh/y; 0.348 Wh/cap.day
 Amount of energy used for settler pumping = 0 GJ/y = 0 kWh/y; 0 Wh/cap.day
 Amount of energy used by sand filter = 59.12 GJ/y = 16422.4 kWh/y; 2.25 Wh/cap.day

Case 5.2: Sand filtration + sedimentation (mode 1) with active chemical precipitation

Model parameters: **spFiltSludgeTSPerc** = 0.04 (4%)
spFiltSSOut = 2 mg TSS/l
spFiltFeCl3In = 0.2 (g FeCl₃/g solution)
spFiltPO4Out = 0.1 mg PO₄-P/l (i.e. < PO₄-P in, active precip.)
spCODtoVS(1,1) = 1/1.42 (g VS/g COD_biodegradable)
spCODtoVS(2,1) = 1/1.9 (g VS/g COD_inert)
spFiltMode = 1 (i.e. sand filtration unit + settler unit)
spFiltBackwash = 0.05 (5% of original input volume) – not in use in mode 1
spFiltEnergy(1,1) = 5400 J/m³
spFiltEnergy(2,1) = 5400 J/m³
spFiltEnergy(3,1) = 180000 J/m³
spFiltEnergy(4,1) = 36000 J/m³

Influent wastewater

BOD7 = 96.8397 g/m³; 159029.9929 kg/y; 21.7849 g/cap.day
 COD total = 195.4434 g/m³; 320956.8057 kg/y; 43.9667 g/cap.day
 COD biosol= 105.204 g/m³; 172765.7888 kg/y; 23.6665 g/cap.day
 COD insol = 29.9942 g/m³; 49256.4169 kg/y; 6.7475 g/cap.day
 COD biopart = 40.0394 g/m³; 65752.6 kg/y; 9.0072 g/cap.day
 COD inpart = 20.2058 g/m³; 33182 kg/y; 4.5455 g/cap.day
 Sum of COD-fractions = 320956.8057 kg/y

Volatile solids (VS) = 128.7051 g/m³; 211359.3368 kg/y; 28.9533 g/cap.day
 Suspended solids (TSS) = 45.8014 g/m³; 75214.9902 kg/y; 10.3034 g/cap.day
 Dissolved solids (TS-TSS) = 771.2888 g/m³; 1266609.1188 kg/y; 173.5081 g/cap.day
 Fixed solids (TS-VS) = 688.385 g/m³; 1130464.7722 kg/y; 154.8582 g/cap.day
 Total solids (TS) = 817.0902 g/m³; 1341824.109 kg/y; 183.8115 g/cap.day
 H2O = 1640856509.3477 kg/y; 224.7749 kg/cap.day
 Total volume = 1642198.3335 m³/y; 4499.1735 m³/day
 VS content = 0.012871 %
 TSS content = 0.0045801 %
 TS content = 0.081709 %

Total nitrogen = 80.2915 g/m³; 131854.636 kg/y; 18.0623 g/cap.day
 N-NH₃ & N-NH₄ = 51.993 g/m³; 85382.8033 kg/y; 11.6963 g/cap.day
 N-NO₃ = 0.072313 g/m³; 118.7522 kg/y; 0.016267 g/cap.day
 N-N₂O = 0 g/m³; 0 kg/y; 0 g/cap.day
 N-org,part = 3.0122 g/m³; 4946.7 kg/y; 0.67763 g/cap.day
 N-org,sol = 25.214 g/m³; 41406.3806 kg/y; 5.6721 g/cap.day
 Sum of N-fractions = 131854.636 kg/y
 N content per TSS (N-org,part/TSS) = 6.5767 %
 N content per TS (Total N/TS) = 9.8265 %

Total sulphur = 4.1149 g/m³; 6757.5064 kg/y; 0.92569 g/cap.day
 SO₄-S = 2.6539 g/m³; 4358.2043 kg/y; 0.59701 g/cap.day
 S particulate = 0.13409 g/m³; 220.2 kg/y; 0.030164 g/cap.day
 Sulfide HS-S = 1.3269 g/m³; 2179.1021 kg/y; 0.29851 g/cap.day
 Sum of S-fractions = 6757.5064 kg/y
 S content per TSS (S particulate/TSS) = 0.29276 %
 S content per TS (Total S/TS) = 0.50361 %

Total phosphorus = 1.2729 g/m³; 2090.4036 kg/y; 0.28636 g/cap.day
 PO₄-P = 0.74985 g/m³; 1231.4036 kg/y; 0.16869 g/cap.day
 P particulate = 0.52308 g/m³; 859 kg/y; 0.11767 g/cap.day
 Sum of P-fractions = 2090.4036 kg/y
 P content per TSS (P particulate/TSS) = 1.1421 %
 P content per TS (Total P/TS) = 0.15579 %

Total potassium = 18.9059 g/m³; 31047.2337 kg/y; 4.253 g/cap.day
 Dissolved potassium = 18.8059 g/m³; 30882.9837 kg/y; 4.2305 g/cap.day
 Organically bound potassium = 0.10002 g/m³; 164.25 kg/y; 0.0225 g/cap.day
 K content per TSS (Organically bound K/TSS) = 0.21837 %
 K content per TS (Total K/TS) = 2.3138 %
 Temperature in water = 20 degC

Effluent wastewater

BOD7 = 71.208 g/m³; 116797.2991 kg/y; 15.9996 g/cap.day
 COD total = 137.6004 g/m³; 225695.8448 kg/y; 30.9172 g/cap.day
 COD biosol= 105.2013 g/m³; 172554.0031 kg/y; 23.6375 g/cap.day
 COD insol = 29.9934 g/m³; 49196.0357 kg/y; 6.7392 g/cap.day

The URWARE Wastewater Treatment Plant Models

COD biopart = 1.5988 g/m³; 2622.4091 kg/y; 0.35923 g/cap.day
COD inpart = 0.80684 g/m³; 1323.3968 kg/y; 0.18129 g/cap.day
Sum of COD-fractions = 225695.8448 kg/y

Volatile solids (VS) = 91.422 g/m³; 149952.8456 kg/y; 20.5415 g/cap.day
Suspended solids (TSS) = 2 g/m³; 3280.4543 kg/y; 0.44938 g/cap.day
Dissolved solids (TS-TSS) = 772.0918 g/m³; 1266405.8393 kg/y; 173.4803 g/cap.day
Fixed solids (TS-VS) = 682.6698 g/m³; 1119733.4479 kg/y; 153.3881 g/cap.day
Total solids (TS) = 774.0918 g/m³; 1269686.2935 kg/y; 173.9296 g/cap.day
H₂O = 1638957440.4922 kg/y; 224.5147 kg/cap.day
Total volume = 1640227.1268 m³/y; 4493.773 m³/day
VS content = 0.0091422 %
TSS content = 0.0002 %
TS content = 0.077409 %

Total nitrogen = 77.3976 g/m³; 126949.6545 kg/y; 17.3904 g/cap.day
N-NH₃ & N-NH₄ = 51.9917 g/m³; 85278.1364 kg/y; 11.6819 g/cap.day
N-NO₃ = 0.072311 g/m³; 118.6066 kg/y; 0.016247 g/cap.day
N-N₂O = 0 g/m³; 0 kg/y; 0 g/cap.day
N-org,part = 0.12028 g/m³; 197.2891 kg/y; 0.027026 g/cap.day
N-org,sol = 25.2134 g/m³; 41355.6224 kg/y; 5.6652 g/cap.day
Sum of N-fractions = 126949.6545 kg/y
N content per TSS (N-org,part/TSS) = 6.0141 %
N content per TS (Total N/TS) = 9.9985 %

Total sulphur = 3.9861 g/m³; 6538.0749 kg/y; 0.89563 g/cap.day
SO₄-S = 2.6538 g/m³; 4352.8618 kg/y; 0.59628 g/cap.day
S particulate = 0.0053543 g/m³; 8.7822 kg/y; 0.001203 g/cap.day
Sulfide HS-S = 1.3269 g/m³; 2176.4309 kg/y; 0.29814 g/cap.day
Sum of S-fractions = 6538.0749 kg/y
S content per TSS (S particulate/TSS) = 0.26771 %
S content per TS (Total S/TS) = 0.51494 %

Total phosphorus = 0.12088 g/m³; 198.278 kg/y; 0.027161 g/cap.day
PO₄-P = 0.099997 g/m³; 164.0185 kg/y; 0.022468 g/cap.day
P particulate = 0.020887 g/m³; 34.2595 kg/y; 0.0046931 g/cap.day
Sum of P-fractions = 198.278 kg/y
P content per TSS (P particulate/TSS) = 1.0444 %
P content per TS (Total P/TS) = 0.015616 %

Total potassium = 18.8094 g/m³; 30851.6764 kg/y; 4.2263 g/cap.day
Dissolved potassium = 18.8054 g/m³; 30845.1257 kg/y; 4.2254 g/cap.day
Organically bound potassium = 0.0039938 g/m³; 6.5508 kg/y; 0.00089737 g/cap.day
K content per TSS (Organically bound K/TSS) = 0.19969 %
K content per TS (Total K/TS) = 2.4299 %
Temperature in water = 20 degC

Sludge stream

BOD₇ = 20978.4452 g/m³; 42232.6938 kg/y; 5.7853 g/cap.day
COD total = 47319.4264 g/m³; 95260.9609 kg/y; 13.0494 g/cap.day
COD biosol = 105.2013 g/m³; 211.7857 kg/y; 0.029012 g/cap.day
COD insol = 29.9934 g/m³; 60.3812 kg/y; 0.0082714 g/cap.day
COD biopart = 31358.9574 g/m³; 63130.1909 kg/y; 8.648 g/cap.day
COD inpart = 15825.2742 g/m³; 31858.6032 kg/y; 4.3642 g/cap.day
Sum of COD-fractions = 95260.9609 kg/y

Volatile solids (VS) = 30502.736 g/m³; 61406.4912 kg/y; 8.4118 g/cap.day
Suspended solids (TSS) = 39227.9082 g/m³; 78971.5455 kg/y; 10.818 g/cap.day

The URWARE Wastewater Treatment Plant Models

Dissolved solids (TS-TSS) = 772.0918 g/m³; 1554.3342 kg/y; 0.21292 g/cap.day
Fixed solids (TS-VS) = 9497.264 g/m³; 19119.3885 kg/y; 2.6191 g/cap.day
Total solids (TS) = 40000 g/m³; 80525.8797 kg/y; 11.0309 g/cap.day
H₂O = 1932621.1121 kg/y; 0.26474 kg/cap.day
Total volume = 2013.147 m³/y; 5.5155 m³/day
VS content = 3.0503 %
TSS content = 3.9228 %
TS content = 4 %

Total nitrogen = 2436.4746 g/m³; 4904.9815 kg/y; 0.67192 g/cap.day
N-NH₃ & N-NH₄ = 51.9917 g/m³; 104.6669 kg/y; 0.014338 g/cap.day
N-NO₃ = 0.072311 g/m³; 0.14557 kg/y; 1.9941e-05 g/cap.day
N-N₂O = 0 g/m³; 0 kg/y; 0 g/cap.day
N-org,part = 2359.1973 g/m³; 4749.4109 kg/y; 0.6506 g/cap.day
N-org,sol = 25.2134 g/m³; 50.7582 kg/y; 0.0069532 g/cap.day
Sum of N-fractions = 4904.9815 kg/y
N content per TSS (N-org,part/TSS) = 6.0141 %
N content per TS (Total N/TS) = 6.0912 %

Total sulphur = 108.9993 g/m³; 219.4316 kg/y; 0.030059 g/cap.day
SO₄-S = 2.6538 g/m³; 5.3425 kg/y; 0.00073185 g/cap.day
S particulate = 105.0185 g/m³; 211.4178 kg/y; 0.028961 g/cap.day
Sulfide HS-S = 1.3269 g/m³; 2.6713 kg/y; 0.00036593 g/cap.day
Sum of S-fractions = 219.4316 kg/y
S content per TSS (S particulate/TSS) = 0.26771 %
S content per TS (Total S/TS) = 0.2725 %

Total phosphorus = 939.8845 g/m³; 1892.1256 kg/y; 0.2592 g/cap.day
PO₄-P = 0.099997 g/m³; 0.20131 kg/y; 2.7577e-05 g/cap.day
P particulate = 939.7845 g/m³; 1891.9243 kg/y; 0.25917 g/cap.day
Sum of P-fractions = 1892.1256 kg/y
P content per TSS (P particulate/TSS) = 2.3957 %
P content per TS (Total P/TS) = 2.3497 %

Total potassium = 97.1401 g/m³; 195.5573 kg/y; 0.026789 g/cap.day
Dissolved potassium = 18.8054 g/m³; 37.858 kg/y; 0.005186 g/cap.day
Organically bound potassium = 78.3347 g/m³; 157.6992 kg/y; 0.021603 g/cap.day
K content per TSS (Organically bound K/TSS) = 0.19969 %
K content per TS (Total K/TS) = 0.24285 %
Temperature in water = 20 degC

Extra output variables

Added FeCl₃ = 8388.1 kg/y; 1.149 g/cap.day
Amount of total energy used = 86.17 GJ/y = 23935.7 kWh/y; 3.28 Wh/cap.day
Amount of energy used for mixing = 8.868 GJ/y = 2463.4 kWh/y; 0.337 Wh/cap.day
Amount of energy used for sludge scrapers = 0.443 GJ/y = 123.2 kWh/y; 0.0168 Wh/cap.day
Amount of energy used for settler pumping = 14.78 GJ/y = 4105.6 kWh/y; 0.562 Wh/cap.day
Amount of energy used by sand filter = 62.08 GJ/y = 17243.5 kWh/y; 2.36 Wh/cap.day

Case 5.3: Sand filtration only (mode 0) but connected to a separate thickener model as defined in Chapter 3. Chemical precipitation active in the sand filter. The thickener effluent is recycled back to the sand filter (as is shown in Figure 5.1).

Model parameters: **spFiltSludgeTSPerc** = 0.04 (4%) – not in use
spFiltSSOut = 2 mg TSS/l
spFiltFeCl3In = 0.2 (g FeCl3/g solution)
spFiltPO4Out = 0.1 mg PO4-P/l (i.e. < PO4-P in, active precip.)
spCODtoVS(1,1) = 1/1.42 (g VS/g COD_biodegradable)
spCODtoVS(2,1) = 1/1.9 (g VS/g COD_inert)
spFiltMode = 0 (i.e. only sand filtration unit)
spFiltBackwash = 0.05 (5% of original input volume)
spFiltEnergy(1,1) = 5400 J/m³
spFiltEnergy(2,1) = 5400 J/m³
spFiltEnergy(3,1) = 180000 J/m³
spFiltEnergy(4,1) = 36000 J/m³
spThickSludgeTSPerc = 0.04 (4%)
spThickRed = 0.9 (90%)
spCODtoVS(1,1) = 1/1.42 (g VS/g COD_biodegradable)
spCODtoVS(2,1) = 1/1.9 (g VS/g COD_inert)
spThickEnergy(1,1) = 5400 J/m³
spThickEnergy(2,1) = 180000 J/m³

Influent wastewater (effluent from the primary settler (Case 2.2) not including the recycle stream from the thickener attached to the sandfilter)

BOD7 = 96.8397 g/m³; 159029.9929 kg/y; 21.7849 g/cap.day
 COD total = 195.4434 g/m³; 320956.8057 kg/y; 43.9667 g/cap.day
 COD biosol= 105.204 g/m³; 172765.7888 kg/y; 23.6665 g/cap.day
 COD insol = 29.9942 g/m³; 49256.4169 kg/y; 6.7475 g/cap.day
 COD biopart = 40.0394 g/m³; 65752.6 kg/y; 9.0072 g/cap.day
 COD inpart = 20.2058 g/m³; 33182 kg/y; 4.5455 g/cap.day
 Sum of COD-fractions = 320956.8057 kg/y

Volatile solids (VS) = 128.7051 g/m³; 211359.3368 kg/y; 28.9533 g/cap.day
 Suspended solids (TSS) = 45.8014 g/m³; 75214.9902 kg/y; 10.3034 g/cap.day
 Dissolved solids (TS-TSS) = 771.2888 g/m³; 1266609.1188 kg/y; 173.5081 g/cap.day
 Fixed solids (TS-VS) = 688.385 g/m³; 1130464.7722 kg/y; 154.8582 g/cap.day
 Total solids (TS) = 817.0902 g/m³; 1341824.109 kg/y; 183.8115 g/cap.day
 H2O = 1640856509.3477 kg/y; 224.7749 kg/cap.day
 Total volume = 1642198.3335 m³/y; 4499.1735 m³/day
 VS content = 0.012871 %
 TSS content = 0.0045801 %
 TS content = 0.081709 %

The URWARE Wastewater Treatment Plant Models

Total nitrogen = 80.2915 g/m³; 131854.636 kg/y; 18.0623 g/cap.day
N-NH₃ & N-NH₄ = 51.993 g/m³; 85382.8033 kg/y; 11.6963 g/cap.day
N-NO₃ = 0.072313 g/m³; 118.7522 kg/y; 0.016267 g/cap.day
N-N₂O = 0 g/m³; 0 kg/y; 0 g/cap.day
N-org,part = 3.0122 g/m³; 4946.7 kg/y; 0.67763 g/cap.day
N-org,sol = 25.214 g/m³; 41406.3806 kg/y; 5.6721 g/cap.day
Sum of N-fractions = 131854.636 kg/y
N content per TSS (N-org,part/TSS) = 6.5767 %
N content per TS (Total N/TS) = 9.8265 %

Total sulphur = 4.1149 g/m³; 6757.5064 kg/y; 0.92569 g/cap.day
SO₄-S = 2.6539 g/m³; 4358.2043 kg/y; 0.59701 g/cap.day
S particulate = 0.13409 g/m³; 220.2 kg/y; 0.030164 g/cap.day
Sulfide HS-S = 1.3269 g/m³; 2179.1021 kg/y; 0.29851 g/cap.day
Sum of S-fractions = 6757.5064 kg/y
S content per TSS (S particulate/TSS) = 0.29276 %
S content per TS (Total S/TS) = 0.50361 %

Total phosphorus = 1.2729 g/m³; 2090.4036 kg/y; 0.28636 g/cap.day
PO₄-P = 0.74985 g/m³; 1231.4036 kg/y; 0.16869 g/cap.day
P particulate = 0.52308 g/m³; 859 kg/y; 0.11767 g/cap.day
Sum of P-fractions = 2090.4036 kg/y
P content per TSS (P particulate/TSS) = 1.1421 %
P content per TS (Total P/TS) = 0.15579 %

Total potassium = 18.9059 g/m³; 31047.2337 kg/y; 4.253 g/cap.day
Dissolved potassium = 18.8059 g/m³; 30882.9837 kg/y; 4.2305 g/cap.day
Organically bound potassium = 0.10002 g/m³; 164.25 kg/y; 0.0225 g/cap.day
K content per TSS (Organically bound K/TSS) = 0.21837 %
K content per TS (Total K/TS) = 2.3138 %
Temperature in water = 20 degC

Effluent wastewater (from the sand filter)

BOD₇ = 71.208 g/m³; 116797.2991 kg/y; 15.9996 g/cap.day
COD total = 137.6004 g/m³; 225695.8449 kg/y; 30.9172 g/cap.day
COD biosol = 105.2013 g/m³; 172554.0031 kg/y; 23.6375 g/cap.day
COD insol = 29.9934 g/m³; 49196.0357 kg/y; 6.7392 g/cap.day
COD biopart = 1.5988 g/m³; 2622.4092 kg/y; 0.35923 g/cap.day
COD inpart = 0.80684 g/m³; 1323.3968 kg/y; 0.18129 g/cap.day
Sum of COD-fractions = 225695.8449 kg/y

Volatile solids (VS) = 91.422 g/m³; 149952.8457 kg/y; 20.5415 g/cap.day
Suspended solids (TSS) = 2 g/m³; 3280.4543 kg/y; 0.44938 g/cap.day
Dissolved solids (TS-TSS) = 772.0918 g/m³; 1266405.839 kg/y; 173.4803 g/cap.day
Fixed solids (TS-VS) = 682.6698 g/m³; 1119733.4476 kg/y; 153.3881 g/cap.day
Total solids (TS) = 774.0918 g/m³; 1269686.2933 kg/y; 173.9296 g/cap.day
H₂O = 1638957440.5182 kg/y; 224.5147 kg/cap.day
Total volume = 1640227.1268 m³/y; 4493.773 m³/day
VS content = 0.0091422 %
TSS content = 0.0002 %
TS content = 0.077409 %

Total nitrogen = 77.3976 g/m³; 126949.6545 kg/y; 17.3904 g/cap.day
N-NH₃ & N-NH₄ = 51.9917 g/m³; 85278.1364 kg/y; 11.6819 g/cap.day
N-NO₃ = 0.072311 g/m³; 118.6066 kg/y; 0.016247 g/cap.day
N-N₂O = 0 g/m³; 0 kg/y; 0 g/cap.day
N-org,part = 0.12028 g/m³; 197.2891 kg/y; 0.027026 g/cap.day
N-org,sol = 25.2134 g/m³; 41355.6224 kg/y; 5.6652 g/cap.day

The URWARE Wastewater Treatment Plant Models

Sum of N-fractions = 126949.6545 kg/y
N content per TSS (N-org,part/TSS) = 6.0141 %
N content per TS (Total N/TS) = 9.9985 %

Total sulphur = 3.9861 g/m³; 6538.0749 kg/y; 0.89563 g/cap.day
SO₄-S = 2.6538 g/m³; 4352.8618 kg/y; 0.59628 g/cap.day
S particulate = 0.0053543 g/m³; 8.7822 kg/y; 0.001203 g/cap.day
Sulfide HS-S = 1.3269 g/m³; 2176.4309 kg/y; 0.29814 g/cap.day
Sum of S-fractions = 6538.0749 kg/y
S content per TSS (S particulate/TSS) = 0.26771 %
S content per TS (Total S/TS) = 0.51494 %

Total phosphorus = 0.12348 g/m³; 202.5344 kg/y; 0.027744 g/cap.day
PO₄-P = 0.099998 g/m³; 164.0187 kg/y; 0.022468 g/cap.day
P particulate = 0.023482 g/m³; 38.5157 kg/y; 0.0052761 g/cap.day
Sum of P-fractions = 202.5344 kg/y
P content per TSS (P particulate/TSS) = 1.1741 %
P content per TS (Total P/TS) = 0.015952 %

Total potassium = 18.8094 g/m³; 30851.6764 kg/y; 4.2263 g/cap.day
Dissolved potassium = 18.8054 g/m³; 30845.1257 kg/y; 4.2254 g/cap.day
Organically bound potassium = 0.0039938 g/m³; 6.5508 kg/y; 0.00089737 g/cap.day
K content per TSS (Organically bound K/TSS) = 0.19969 %
K content per TS (Total K/TS) = 2.4299 %
Temperature in water = 20 degC

Sludge stream (from the thickener)

BOD₇ = 20978.4455 g/m³; 42232.6937 kg/y; 5.7853 g/cap.day
COD total = 47319.4271 g/m³; 95260.9608 kg/y; 13.0494 g/cap.day
COD biosol = 105.2013 g/m³; 211.7856 kg/y; 0.029012 g/cap.day
COD insol = 29.9934 g/m³; 60.3812 kg/y; 0.0082714 g/cap.day
COD biopart = 31358.958 g/m³; 63130.1908 kg/y; 8.648 g/cap.day
COD inpart = 15825.2745 g/m³; 31858.6032 kg/y; 4.3642 g/cap.day
Sum of COD-fractions = 95260.9608 kg/y

Volatile solids (VS) = 30502.7365 g/m³; 61406.4911 kg/y; 8.4118 g/cap.day
Suspended solids (TSS) = 39227.9082 g/m³; 78971.5442 kg/y; 10.818 g/cap.day
Dissolved solids (TS-TSS) = 772.0918 g/m³; 1554.3342 kg/y; 0.21292 g/cap.day
Fixed solids (TS-VS) = 9497.2635 g/m³; 19119.3872 kg/y; 2.6191 g/cap.day
Total solids (TS) = 40000 g/m³; 80525.8783 kg/y; 11.0309 g/cap.day
H₂O = 1932621.0799 kg/y; 0.26474 kg/cap.day
Total volume = 2013.147 m³/y; 5.5155 m³/day
VS content = 3.0503 %
TSS content = 3.9228 %
TS content = 4 %

Total nitrogen = 2436.4746 g/m³; 4904.9815 kg/y; 0.67192 g/cap.day
N-NH₃ & N-NH₄ = 51.9917 g/m³; 104.6669 kg/y; 0.014338 g/cap.day
N-NO₃ = 0.072311 g/m³; 0.14557 kg/y; 1.9941e-05 g/cap.day
N-N₂O = 0 g/m³; 0 kg/y; 0 g/cap.day
N-org,part = 2359.1973 g/m³; 4749.4109 kg/y; 0.6506 g/cap.day
N-org,sol = 25.2134 g/m³; 50.7582 kg/y; 0.0069532 g/cap.day
Sum of N-fractions = 4904.9815 kg/y
N content per TSS (N-org,part/TSS) = 6.0141 %
N content per TS (Total N/TS) = 6.0912 %

Total sulphur = 108.9993 g/m³; 219.4316 kg/y; 0.030059 g/cap.day
SO₄-S = 2.6538 g/m³; 5.3425 kg/y; 0.00073185 g/cap.day

S particulate = 105.0185 g/m³; 211.4178 kg/y; 0.028961 g/cap.day
 Sulfide HS-S = 1.3269 g/m³; 2.6713 kg/y; 0.00036593 g/cap.day
 Sum of S-fractions = 219.4316 kg/y
 S content per TSS (S particulate/TSS) = 0.26771 %
 S content per TS (Total S/TS) = 0.2725 %

Total phosphorus = 937.7702 g/m³; 1887.8691 kg/y; 0.25861 g/cap.day
 PO₄-P = 0.099998 g/m³; 0.20131 kg/y; 2.7577e-05 g/cap.day
 P particulate = 937.6702 g/m³; 1887.6678 kg/y; 0.25858 g/cap.day
 Sum of P-fractions = 1887.8691 kg/y
 P content per TSS (P particulate/TSS) = 2.3903 %
 P content per TS (Total P/TS) = 2.3444 %

Total potassium = 97.1401 g/m³; 195.5573 kg/y; 0.026789 g/cap.day
 Dissolved potassium = 18.8054 g/m³; 37.858 kg/y; 0.005186 g/cap.day
 Organically bound potassium = 78.3347 g/m³; 157.6992 kg/y; 0.021603 g/cap.day
 K content per TSS (Organically bound K/TSS) = 0.19969 %
 K content per TS (Total K/TS) = 0.24285 %

Temperature in water = 20 degC

Extra output variables

Sand filter outputs

Added FeCl₃ in sand filter = 8388.1 kg/y; 1.149 g/cap.day
 Amount of total energy used = 71.30 GJ/y = 19806.9 kWh/y; 2.71 Wh/cap.day
 Amount of energy used for mixing = 9.301 GJ/y = 2583.5 kWh/y; 0.354 Wh/cap.day
 Amount of energy used for sludge scrapers = 0 GJ/y = 0 kWh/y; 0 Wh/cap.day
 Amount of energy used for settler pumping = 0 GJ/y = 0 kWh/y; 0 Wh/cap.day
 Amount of energy used by sand filter = 62.00 GJ/y = 17223.4 kWh/y; 2.36 Wh/cap.day

Thickener outputs

Amount of energy used in thickener = 15.2 GJ/y = 4228.7 kWh/y; 0.579 Wh/cap.day
 Amount of energy used for thickener scrapers = 0.443 GJ/y = 123.2 kWh/y; 0.017 Wh/cap.day
 Amount of energy used for thickener pumping = 14.78 GJ/y = 4105.5 kWh/y; 0.562 Wh/cap.day

Obviously the differences between Cases 5.1 and 5.2 are clearly visible because in one case we are simulating only a sand filter and in the other a sand filter in combination with a settler. This is evident when looking at the solids concentrations in the underflow and the underflow volume for the two cases. The extra energy required for Case 5.2 is obviously related to the thickener. The amount of chemicals used is identical (as it is based on the influent PO₄-P concentration). The sand filter effluent concentrations are identical for both cases, which is a consequence of the way the user is able to define the effluent TSS concentration but the volume of water is different. In the demonstrated cases, however, the differences in water volume are limited but that is a consequence of how **spFiltBackwash** and **spFiltTSludgePerc** are chosen in the two cases (here they are chosen to give fairly similar results).

When we compare the results from Cases 5.2 and 5.3 it is encouraging to see that the results are for all practical reasons identical although in Case 5.2 the internal settler of the sand filter was used and in Case 5.3 the stand-alone thickener model was used and the effluent water recycled back to the sand filter. Some minute differences related to energy use are visible. Part of the difference can be explained by the fact that when operated in mode 1 the

sand filter assumes that the effluent flow from the thickener is returned to the sand filter after the chemical mixing zone (which for practical reasons is not the case when combining two models as in Case 5.3). There are also some small practical modelling issues related to the previously discussed global parameter **spFiltInputVolume** and the assumed 5% backwash flow in mode 1, which plays a role in this detailed comparison.

Case 5.3 represents the first test presented in this report where two of the developed models have been connected and recirculations are actually performed. The results are an indication that the methods and algorithms used in the two models are correct (or at least equally erroneous).

In order to demonstrate that the behaviour of the sand filtration model is reasonable, a comparative simulation is done with the general wastewater treatment plant simulator GPS-X (Hydromantis, 1999). In GPS-X, three different sand filtration models are available and the comparison is done using the simplest one. Consequently, we only simulate a stand-alone continuous sand filter with no precipitation active. The influent wastewater is characterised similar to the URWARE input (although not as many variables are used in GPS-X). The two calibration parameters of the GPS-X model are slightly adjusted to get results similar to the URWARE simulation. These parameters are: backwash flow fraction and backwash solids mass fraction. These are set to 5% and 96.5%, respectively. No physical design parameters are available for the empirical model. Based on these simple modifications we can see that the results are similar to the URWARE results. It would be possible to come even closer with more elaborate calibration but it is certainly encouraging to see that the GPS-X model performs so similar to URWARE without any major changes for the steady-state behaviour. Note that the more advanced GPS-X models include biological reactions within the sandfilter, distribution of suspended solids diameter and sand diameter, deterioration of the filter after backwash, etc. In the case below, the URWARE sand filtration model is simulated in mode 0 without active chemical precipitation – otherwise the simulation is identical to Case 5.1.

Influent wastewater (from GPS-X, URWARE inputs within parenthesis)

BOD7 = 94.4 g/m³ (96.8)

COD total = 195.4 g/m³ (195.4)

COD biosol = 105.2 g/m³ (105.2)

COD insol = 30 g/m³ (30)

COD biopart = 40.0 g/m³ (40.0)

COD inpart = 20.2 g/m³ (20.2)

Volatile suspended solids (VSS) = 36.7 g/m³ (not available in URWARE but estimated as 38.8 g/m³)

Suspended solids (TSS) = 45.8 g/m³ (45.8)

Flow rate = 4499.2 m³/d (4499.2)

VSS content = 0.00367 % (not available in URWARE but 0.00388%)

TSS content = 0.00458 % (0.00458)

Total nitrogen = 80.3 g/m³ (80.3)

N-NH₃ & N-NH₄ = 52 g/m³ (52)

N-NO₃ = 0.07 g/m³ (0.07)

N-org,part = 3.0 g/m³ (3.0)

N-org,sol = 25.2 g/m³ (25.2)

Effluent wastewater (from GPS-X, URWARE results within parenthesis)

BOD7 = 69.5 g/m3 (71.3)
COD total = 137.8 g/m3 (137.8)
COD biosol= 105.2 g/m3 (105.2)
COD insol = 30 g/m3 (30)
COD biopart = 1.73 g/m3 (1.75)
COD inpart = 0.87 g/m3 (0.88)

Volatile suspended solids (VSS) = 1.58 g/m3 (not available in URWARE but estimated as 1.68 g/m3)
Suspended solids (TSS) = 1.98 g/m3 (2.0)
Flow rate (effluent) = 4274.2 m3/d (4274.2)
VSS content = 0.00016 % (not available in URWARE but 0.00017%)
TSS content = 0.0002 % (0.0002)

Total nitrogen = 77.4 g/m3 (77.4)
N-NH3 & N-NH4 = 52 g/m3 (52)
N-NO3 = 0.07 g/m3 (0.07)
N-org,part = 0.13 g/m3 (0.13)
N-org,sol = 25.2 g/m3 (25.2)

Sludge stream (from GPS-X, URWARE results within parenthesis)

BOD7 = 567.5 g/m3 (581.9)
COD total = 1290.7 g/m3 (1290.2)
COD biosol= 105.2 g/m3 (105.2)
COD insol = 30 g/m3 (30)
COD biopart = 768.0 g/m3 (767.6)
COD inpart = 387.5 g/m3 (387.4)

Volatile suspended solids (VSS) = 703.3 g/m3 (not available in URWARE but estimated as 744.5 g/m3)
Suspended solids (TSS) = 879.1 g/m3 (878.0)
Flow rate (underflow) = 225.0 m3/d (225.0)
VSS content = 0.0703 % (not available in URWARE but 0.0744%)
TSS content = 0.0879 % (0.0878)

Total nitrogen = 135.0 g/m3 (135.0)
N-NH3 & N-NH4 = 52 g/m3 (52)
N-NO3 = 0.07 g/m3 (0.07)
N-org,part = 57.8 g/m3 (57.7)
N-org,sol = 25.22 g/m3 (25.2)

It is certainly possible to increase the complexity of the sand filtration model dramatically but at this stage it is encouraging to see the similarities between URWARE and GPS-X, even at this low degree of complexity. Once again the overall purpose of the URWARE model must be considered and it will set an upper limit for the model complexity.

6

Activated sludge

The URWARE model with the most significant impact on simulation results is certainly the activated sludge module. It represents the main ‘conversion chamber’ in the WWTP in terms of transforming substances in the wastewater. It consists of four different models:

- `spASInput.m` – converts the URWARE 84 element vector into a 91 elements vector suitable for the AS model equations. This model must be used as the first part of the activated sludge process.
- `spASAnoxModel.m` – describes the behaviour of an anoxic activated sludge system. Can be used prior to the aerobic model (pre-denitrification) or after the aerobic model (post-denitrification). Accepts three inputs – normal influent, internal recycle flow and sludge recycle flow.
- `spASAerobModel.m` – describes the behaviour of an aerobic activated sludge system. Can be used prior to the anoxic model (post-denitrification) or after the anoxic model (pre-denitrification). Accepts three inputs – normal influent, internal recycle flow and sludge recycle flow.
- `spASIdealSMoDel.m` – describes the behaviour of a secondary clarifier and also combines the 91 elements vector into an 84 elements vector when wastewater is passed on to other modules as effluent wastewater or sludge wastage.

The activated sludge models are different from the rest of the URWARE models in many ways. Firstly, they are based on an extended vector of 91 elements. Secondly, they are fully dynamic models based on the traditional Activated Sludge Model no. 1 (ASM1) (Henze *et al.*, 1987) with considerable extensions. This means that the models are represented by differential equations rather than steady-state relationships. Inspiration for some of the model extensions have been adopted from the ASM2d and ASM3 models (Henze *et al.*, 1999; 2000). Thirdly, the temporal perception is different. A time unit in the rest of URWARE represents one year whereas a time unit within the activated sludge model represents one day. This is something the user does not have to worry about but it means

that all simulations of URWARE should be run for at least 100 time units to guarantee a stable steady-state solution. The 100 time units are for the activated sludge system to reach steady state (i.e. 100 days of operation) and not required for the rest of URWARE, which finds its steady state within a few time steps.

No true anaerobic AS model is available for URWARE at this stage, for example to describe enhanced biological phosphorus removal. Bio-P behaviour can be somewhat simulated by defining some model parameters in a special way but it is still just a rough way of producing reasonable results and should not be considered a final solution. Simultaneous precipitation of phosphorus is not included. All precipitation must be performed in the primary or final sedimentation units or in the sand filter. The AS models are by default created so that one anoxic and one aerobic reactor together with a secondary clarifier can be connected. However, if the user needs to simulate several reactors in series (towards a plug-flow system) this can easily be accomplished by some small adjustments in the spInit file (i.e. in relation to the parameters defining hydraulic retention time, sludge age, anoxic-aerobic volume fraction).

In this chapter we assume that the reader is familiar with ASM1 (also ASM2d and ASM3) terminology and representation. However, several details of the models are not discussed in order to avoid a dramatically oversized document. The interested reader is referred to the source code in Appendices N-Q for a complete description. Moreover, thousands of journal papers, reports and books are available where the general ASM models are analysed and discussed (e.g. Copp, 2002; Henze *et al.*, 1987; 1995; 1999; 2000; Jeppsson, 1996; Orhon and Artan, 1994). Consequently, there is no lack of information for any reader who wants to study the details of the fundamental AS models.

6.1 Adjusting wastewater input to the activated sludge system

The ASM1 requires a somewhat different representation of the wastewater than is used by URWARE. Therefore the influent wastewater passes through a model named spASInput, which creates some extra state variables more suited for ASM1. At all times the mass balances are maintained. The extra variables are:

- slowly biodegradable substrate as COD, element 85
- heterotrophic biomass as COD, element 86
- autotrophic biomass as COD, element 87
- soluble organic N associated with element 75, element 88
- particulate organic N associated with element 85 = XND, element 89
- particulate organic P associated with element 85 = XPD, element 90
- particulate organic S associated with inerts, element 91

It must be understood that this module does not represent a physical reactor of any kind. It has no equivalence in reality. It is simply a module that divides and adjusts some of the input vector variables so that the

influent wastewater is represented and characterised in a fashion suitable for the activated sludge models presented later in this chapter. In terms of mass balances the inputs and the outputs of this module are identical (e.g. for COD, BOD, TSS, TS, N, P, S, K, H₂O) as is demonstrated in Case 6.1 below. Consequently, no energy consumption is associated with this module.

In Figure 8.2 it is shown how this module is connected to the rest of the activated sludge system. The complete source code for the model is given in Appendix N.

For COD-based substances the amounts of heterotrophic and autotrophic biomass are essential. As URWARE only represents particulate biodegradable COD with one variable (no 77), this variable is divided into three new ones (85, 86 and 87), representing slowly biodegradable substrate, Heterotrophs and Autotrophs.

```
y(85) = 0.999*y(77); %assume 99.9% of all influent biodegradable, particulate COD is XS
y(86) = 0.0009*y(77); %assume 0.09% heterotrophic biomass in influent
y(87) = 0.0001*y(77); %assume 0.01% autotrophic biomass in influent
```

This division will feed the activated sludge system with a small fraction of biomass, which will then be able to grow if the conditions for sustained growth are adequate.

For nitrogen only the organic N associated with readily and slowly biodegradable substrate is modelled (S_{ND} and X_{ND}) in a direct fashion whereas organic nitrogen related to inert material and biomass is not explicitly described in ASM1. URWARE represents nitrogen as all soluble organic nitrogen (44) and all particulate organic nitrogen (81). Therefore we create elements 88 and 89 as the ASM1 state variables S_{ND} and X_{ND}. For simplicity we assume the same N content in influent inert particulate and biodegradable particulate material (in reality the N content of biomass may be somewhat higher than in the inert particulate material, see ASM2d (Henze *et al.*, 1999; 2000) but in the influent wastewater the biomass content is normally very low in comparison to particulate inerts and particulate substrates), whereas we assume a three times higher N content in soluble biodegradable COD than in inert soluble COD, which is in accordance with the default description in ASM2d. We create these new variables from the N available in elements 44 and 81 as shown below:

```
XND = y(81)*y(85)/(y(77)+y(78));
N_part_rem = y(81) - XND; % the remaining part of particulate N
SND = y(44)*3*y(75)/(3*y(75)+y(76));
N_sol_rem = y(44) - SND; % the remaining part of soluble N
y(44) = N_sol_rem;
y(88) = SND;
y(81) = N_part_rem;
y(89) = XND;
```

A similar principle is used for phosphorus. ASM1 does not include phosphorus reactions of any kind but in the extended version created for URWARE the nutrient requirements for biomass in terms of P and N are modelled according to the same principles and therefore also the

state variables are based on the same principle. URWARE represents phosphorus as soluble phosphate (79) and particulate organic phosphorus (80). Variable 79 actually represents the sum of all soluble forms of phosphorus (organic and inorganic) but we normally refer to it as phosphate, which is often the dominating compound. For simplicity we assume the same P content in influent inert particulate and biodegradable particulate material (as the biomass fraction in the influent is low this is a reasonable assumption), whereas we assume that all phosphate is associated with soluble biodegradable substrate and available for growth. Note that it is only a specific model representation of phosphate in order to use similar types of equations as defined for the organic soluble nitrogen, i.e. the model does not differentiate between organic soluble phosphorus and free phosphate but lumps them into one variable, which is available for growth of microorganisms. Consequently, the phosphate variable is not modified. We create a new variable (90) to represent organic phosphorus associated with slowly biodegradable substrate and element 80 then becomes the remaining part associated with inert particulate material. From the organic P available in element 80 we conclude the following:

```
P_part_bio = y(80)*y(85)/(y(77)+y(78));
P_part_inert = y(80) - P_part_bio;    % the remaining part of particulate P, in the inerts
y(90) = P_part_bio;
y(80) = P_part_inert;
```

For sulphur (not part of standard ASM1) we assume the same S content in influent inert particulate and biodegradable particulate material, whereas we assume that all soluble S (sulphate) is associated with soluble biodegradable substrate and available for growth. Consequently, the sulphate variable is not modified. Any sulphide (HS^-) in the influent wastewater also passes through the module without modifications. In the actual anoxic and aerobic models the sulphide is certainly affected but here we are only preparing the input vector to suit the models later described in Sections 6.2 and 6.3. We create a new variable (91) to represent organic sulphur associated with inert particulate COD and element 46 then becomes the remaining part associated with slowly biodegradable particulate material. From the organic S available in element 46 we conclude the following:

```
S_part_bio = y(46)*y(85)/(y(77)+y(78));
S_part_inert = y(46) - S_part_bio;    % the remaining part of particulate S, in the inerts
y(46) = S_part_bio;
y(91) = S_part_inert;
```

The spASInput finally defines a number of global variables at the time the simulation is initiated. These variables are required by the rest of the AS modules in order to immediately determine the volumes, flow regime and settler underflow concentrations in order to produce the requested sludge age for the entire system. These global parameters are stated below:

```

spASTSFlowIn = u(8); %input volume of TS, assuming 1 kg = 1 dm3
spASWaterFlowIn = u(22); %input volume of water, assuming 1 kg = 1 dm3
spASVolumeFlowIn = u(8) + u(22); %total input volume, assuming 1 kg = 1 dm3
spASDissolvedTSIn = u(8) - u(42)*1e-6*(u(8)+u(22)); %volume of dissolved TS, assuming 1
kg = 1 dm3

```

To demonstrate the general behaviour of the module, one simulation case is presented below. The contents of the influent wastewater to the spASInput are almost identical to the contents of the effluent stream for simulation Case 2.2 in Section 2.1 – Primary sedimentation with active chemical precipitation. The only difference is that the precipitation in the primary settling system now produces an effluent phosphate concentration of 2 g PO₄-P/m³ (i.e. spPreSPO4Out = 2).

Case 6.1: Modification and extension of the influent wastewater vector when entering the AS system.

Influent wastewater

```

BOD7 = 96.8394 g/m3; 159051.9885 kg/y; 21.7879 g/cap.day
COD total = 195.4415 g/m3; 320999.2011 kg/y; 43.9725 g/cap.day
COD biosol= 105.2091 g/m3; 172798.7786 kg/y; 23.6711 g/cap.day
COD insol = 29.9957 g/m3; 49265.8225 kg/y; 6.7487 g/cap.day
COD biopart = 40.0337 g/m3; 65752.6 kg/y; 9.0072 g/cap.day
COD inpart = 20.203 g/m3; 33182 kg/y; 4.5455 g/cap.day
Sum of COD-fractions = 320999.2011 kg/y

```

```

Volatile solids (VS) = 128.704 g/m3; 211387.5194 kg/y; 28.9572 g/cap.day
Suspended solids (TSS) = 44.9623 g/m3; 73847.4571 kg/y; 10.1161 g/cap.day
Dissolved solids (TS-TSS) = 769.7444 g/m3; 1264252.2215 kg/y; 173.1852 g/cap.day
Fixed solids (TS-VS) = 686.0026 g/m3; 1126712.1592 kg/y; 154.3441 g/cap.day
Total solids (TS) = 814.7067 g/m3; 1338099.6786 kg/y; 183.3013 g/cap.day
H2O = 1641093140.9038 kg/y; 224.8073 kg/cap.day
Total volume = 1642431.2406 m3/y; 4499.8116 m3/day
VS content = 0.01287 %
TSS content = 0.0044962 %
TS content = 0.081471 %

```

```

Total nitrogen = 80.2949 g/m3; 131878.8692 kg/y; 18.0656 g/cap.day
N-NH3 & N-NH4 = 51.9955 g/m3; 85399.1072 kg/y; 11.6985 g/cap.day
N-NO3 = 0.072316 g/m3; 118.7748 kg/y; 0.016271 g/cap.day
N-N2O = 0 g/m3; 0 kg/y; 0 g/cap.day
N-org,part = 3.0118 g/m3; 4946.7 kg/y; 0.67763 g/cap.day
N-org,sol = 25.2152 g/m3; 41414.2871 kg/y; 5.6732 g/cap.day
Sum of N-fractions = 131878.8692 kg/y
N content per TSS (N-org,part/TSS) = 6.6985 %
N content per TS (Total N/TS) = 9.8557 %

```

```

Total sulphur = 4.1151 g/m3; 6758.7547 kg/y; 0.92586 g/cap.day
SO4-S = 2.654 g/m3; 4359.0365 kg/y; 0.59713 g/cap.day
S particulate = 0.13407 g/m3; 220.2 kg/y; 0.030164 g/cap.day
Sulfide HS-S = 1.327 g/m3; 2179.5182 kg/y; 0.29856 g/cap.day
Sum of S-fractions = 6758.7547 kg/y
S content per TSS (S particulate/TSS) = 0.29818 %
S content per TS (Total S/TS) = 0.5051 %

```

```

Total phosphorus = 2.5227 g/m3; 4143.3699 kg/y; 0.56758 g/cap.day

```

The URWARE Wastewater Treatment Plant Models

PO4-P = 1.9997 g/m³; 3284.3699 kg/y; 0.44991 g/cap.day
P particulate = 0.52301 g/m³; 859 kg/y; 0.11767 g/cap.day
Sum of P-fractions = 4143.3699 kg/y
P content per TSS (P particulate/TSS) = 1.1632 %
P content per TS (Total P/TS) = 0.30965 %

Total potassium = 18.9068 g/m³; 31053.1308 kg/y; 4.2539 g/cap.day
Dissolved potassium = 18.8068 g/m³; 30888.8808 kg/y; 4.2314 g/cap.day
Organically bound potassium = 0.1 g/m³; 164.25 kg/y; 0.0225 g/cap.day
K content per TSS (Organically bound K/TSS) = 0.22242 %
K content per TS (Total K/TS) = 2.3207 %
Temperature in water = 20 degC

Modified output wastewater vector

BOD7 = 96.8394 g/m³; 159051.9885 kg/y; 21.7879 g/cap.day
COD total = 195.4415 g/m³; 320999.2011 kg/y; 43.9725 g/cap.day
COD biosol = 105.2091 g/m³; 172798.7786 kg/y; 23.6711 g/cap.day
COD insol = 29.9957 g/m³; 49265.8225 kg/y; 6.7487 g/cap.day
COD biopart = 40.0337 g/m³; 65752.6 kg/y; 9.0072 g/cap.day
COD inpart = 20.203 g/m³; 33182 kg/y; 4.5455 g/cap.day
COD slowly biodeg part = 39.9937 g/m³; 65686.8474 kg/y; 8.9982 g/cap.day
COD Heterotrophs = 0.03603 g/m³; 59.1773 kg/y; 0.0081065 g/cap.day
COD Autotrophs = 0.0040034 g/m³; 6.5753 kg/y; 0.00090072 g/cap.day
Sum of COD-fractions = 320999.2011 kg/y

Volatile solids (VS) = 128.704 g/m³; 211387.5194 kg/y; 28.9572 g/cap.day
Suspended solids (TSS) = 44.9623 g/m³; 73847.4571 kg/y; 10.1161 g/cap.day
Dissolved solids (TS-TSS) = 769.7444 g/m³; 1264252.2215 kg/y; 173.1852 g/cap.day
Fixed solids (TS-VS) = 686.0026 g/m³; 1126712.1592 kg/y; 154.3441 g/cap.day
Total solids (TS) = 814.7067 g/m³; 1338099.6786 kg/y; 183.3013 g/cap.day
H2O = 1641093140.9038 kg/y; 224.8073 kg/cap.day
Total volume = 1642431.2406 m³/y; 4499.8116 m³/day
VS content = 0.01287 %
TSS content = 0.0044962 %
TS content = 0.081471 %

Total nitrogen = 80.2949 g/m³; 131878.8692 kg/y; 18.0656 g/cap.day
N-NH₃ & N-NH₄ = 51.9955 g/m³; 85399.1072 kg/y; 11.6985 g/cap.day
N-NO₃ = 0.072316 g/m³; 118.7748 kg/y; 0.016271 g/cap.day
N-N₂O = 0 g/m³; 0 kg/y; 0 g/cap.day
N-org,part not Snd = 1.0121 g/m³; 1662.3775 kg/y; 0.22772 g/cap.day
N-org,sol not Snd = 2.1884 g/m³; 3594.231 kg/y; 0.49236 g/cap.day
N-org, Snd = 23.0269 g/m³; 37820.0562 kg/y; 5.1808 g/cap.day
N-org Xnd = 1.9997 g/m³; 3284.3225 kg/y; 0.44991 g/cap.day
Sum of N-fractions = 131878.8692 kg/y

Total sulphur = 4.1151 g/m³; 6758.7547 kg/y; 0.92586 g/cap.day
SO₄-S = 2.654 g/m³; 4359.0365 kg/y; 0.59713 g/cap.day
S particulate,bio = 0.089014 g/m³; 146.2001 kg/y; 0.020027 g/cap.day
Sulfide HS-S = 1.327 g/m³; 2179.5182 kg/y; 0.29856 g/cap.day
S particulate,inert = 0.045055 g/m³; 73.9999 kg/y; 0.010137 g/cap.day
Sum of S-fractions = 6758.7547 kg/y

Total phosphorus = 2.5227 g/m³; 4143.3699 kg/y; 0.56758 g/cap.day
PO₄-P = 1.9997 g/m³; 3284.3699 kg/y; 0.44991 g/cap.day
P particulate not Xpn = 0.17576 g/m³; 288.6737 kg/y; 0.039544 g/cap.day
P part Xpn = 0.34725 g/m³; 570.3263 kg/y; 0.078127 g/cap.day
Sum of P-fractions = 4143.3699 kg/y

Total potassium = 18.9068 g/m³; 31053.1308 kg/y; 4.2539 g/cap.day
 Dissolved potassium = 18.8068 g/m³; 30888.8808 kg/y; 4.2314 g/cap.day
 Organically bound potassium = 0.1 g/m³; 164.25 kg/y; 0.0225 g/cap.day
 Temperature in water = 20 degC

It is clear that the modifications created by spASInput are modest and do not alter the actual characteristics of the wastewater. However, the changes are essential for the AS models based on ASM1 to behave properly.

6.2 Anoxic bioreactor

The anoxic model is a fully dynamic model based on the ASM1 approach but with many modifications in order to account for the types of substances not accounted for in ASM1 (phosphorus, sulphur, potassium, etc.). The principles of this model are identical to the aerobic model. Switching functions (Monod-type functions) are used to determine whether the model behaves in an anoxic fashion or aerobic fashion. Basically it is only the calculations of the extra output variables that differ between the models, i.e. energy usage and other special outputs. The model is constructed to work together with an aerobic model and the ideal settler model to describe the behaviour of an activated sludge process. However, it can also be used as a fully dynamic stand-alone model. By connecting the different recirculation flows in the fashion desired by the user, the combined modules can describe predenitrification systems, postdenitrification system, simple COD removal plants, COD removal plants with nitrification, etc. The volume of wastewater in the reactor is always considered to be constant and calculated based on the influent flow rate to the AS stage and the user defined parameters setting the anoxic volume fraction and the hydraulic retention time of the bioreactors. Complete mix is also assumed. The model makes use of the global variable spASVolumeFlowIn, which was defined in the previous subsection.

The behaviour of the anoxic reactor model is influenced by 14 parameters defined by the user. Note that several of these parameters are common for both the anoxic and the aerobic models as they must be known to both modules when they are connected via recirculations (see Figures 8.2 and 8.3). These parameters are defined in the main initialisation file for the WWTP-model (spInit.m). The parameters are:

- **spASHydRetTime**: total hydraulic nominal retention time for AS reactors in days (anox + aerob volume).
- **spASAnoxFrac**: fraction of total reactor volume that is anoxic. Actually calculated as $(1 - \text{spASAerobFrac})$.
- **spASAnoxExtCFlow**: flow of external carbon source into the anoxic reactor (m³/d).
- **spASAnoxIntRecFrac**: recycle expressed as the fraction of influent flow recycled internally from the anoxic reactor to some other process ($Q_{\text{intr}} = Q_{\text{in}} * \text{spASAnoxIntRecFrac}$).

- **spCODtoBOD**: conversion factor for calculating BOD_7 from COD_{bio-degradable}. Suggested value 0.65 mg BOD₇/mg COD_{bio-degradable}.
- **spCODtoVS(1,1)**: conversion factor for calculating volatile solids (VS) from biodegradable COD. Suggested value $1/1.42 \approx 0.704$ (Metcalf & Eddy, 1991).
- **spCODtoVS(2,1)**: conversion factor for calculating volatile solids (VS) from inert COD. Suggested value $1/1.9 \approx 0.526$.
- **spCODtoSS(1,1)**: conversion factor for calculating suspended solids (SS) from biodegradable and inert particulate COD. Suggested value 0.75 g SS/g COD.
- **spCODtoSS(2,1)**: conversion factor for calculating suspended solids (SS) from biomass COD. Suggested value 0.9 g SS/g COD.
- **spASAnoxExtCConc**: COD concentration of easily biodegradable external carbon source (g/m³).
- **spASSludgeAge**: requested AS sludge age in days (anox + aerob volume).
- **spASAnoxEnergy(1,1)**: energy required for mixing. Suggested value 2.5 W/m³ of anoxic reactor volume.
- **spASAnoxEnergy(2,1)**: energy required for pumping of any recirculation flows. Suggested value 72000 J/m³ (20 Wh/m³) of pumped flow.
- **spASAnoxEnergy(3,1)**: energy required for aeration (in case of intermittent aeration). Suggested value 1800000 J/kg O₂ (500 Wh/kg O₂).

The parameters above are gathered into the input parameter vector (spASAnoxPAR) in spInit.m and included as an argument in spASAnoxModel.m when calling the actual anoxic reactor model.

Modelling of biological processes is a complex task and therefore a second set of model parameters (32) are required by the anoxic model. These parameters are also defined in the main initialisation file for the WWTP-model (spInit.m) and should normally not be modified by the user unless substantial modelling knowledge exists. Most parameters are common to both the anoxic and aerobic reactor models. The default values are given for 20°C and automatically adjusted within the model for the actual wastewater temperature (by Arrhenius functions). The values represent the default values proposed for the ASM1 model (in some cases for the ASM2d model) and the terminology established by the ASM1 is used whenever possible. As the model is based on the death-regeneration principle the values for yields, decay rates and **f_P** will appear somewhat different than the observed values from an actual plant. However, this effect is related to the model structure rather than a true difference between model values and observed values (see Henze *et al.*, 2000). These model parameters values can actually be converted into the equivalent observed values (see for example Section 6.4 for an **f_P** conversion formula). The parameters are:

- **Y_A = 0.24**: autotrophic yield (g cell COD formed/g N oxidized).
- **Y_H = 0.67**: heterotrophic yield (g cell COD formed/g COD oxidized).

- **f_P = 0.08**: fraction of biomass ending up as inert particulate material (dimensionless).
- **i_XB = 0.086**: mass N/mass COD in biomass.
- **i_XE = 0.06**: mass N/mass COD in inert material.
- **mu_H = 6.0**: maximum specific growth rate for Heterotrophs (day⁻¹).
- **K_S = 20**: half-saturation coefficient for heterotrophic biomass (mg COD/l).
- **K_OH = 0.2**: oxygen half-saturation coefficient for Heterotrophs (mg COD/l).
- **K_NO = 0.5**: nitrate half-saturation coefficient for denitrifying Heterotrophs (mg N/l).
- **b_H_anox = b_H_aerob/2**: heterotrophic decay rate in anoxic conditions (day⁻¹).
- **ny_g = 0.8**: correction factor for mu_H in anoxic conditions (dimensionless).
- **ny_h = 0.4**: correction factor for hydrolysis in anoxic conditions (dimensionless).
- **k_h = 3.0**: maximum specific hydrolysis rate (mass slowly biodegradable COD/(mass cell COD * day)).
- **K_X = 0.03**: half-saturation coefficient for hydrolysis (mass slowly biodegradable COD/mass cell COD).
- **mu_A = 0.8**: max specific growth rate for Autotrophs.
- **K_NH = 1**: ammonia half-saturation coefficient for Autotrophs (mg N/l), i.e. NH₄ = substrate.
- **K_OA = 0.4**: oxygen half-saturation coefficient for Autotrophs (mg COD/l).
- **k_a = 0.08**: ammonification rate (mg COD * day)⁻¹.
- **b_A_anox = b_A_aerob/3**: autotrophic decay rate in anoxic conditions (day⁻¹).
- **K_P = 0.05**: phosphate half-saturation coefficient for microbial growth (mg P/l).
- **i_XBP = 0.02**: mass P/mass COD in biomass.
- **i_XEP = 0.01**: mass P/mass COD in inert material.
- **K_K = 0.05**: potassium half-saturation coefficient for microbial growth (mg K/l).
- **i_XBK = 0.02**: mass K/mass COD in biomass.
- **i_XEK = 0.0**: mass K/mass COD in inert material.
- **b_H_aerob = 0.62**: heterotrophic decay rate in aerobic conditions (day⁻¹).
- **b_A_aerob = 0.2**: autotrophic decay rate in aerobic conditions (day⁻¹).
- **K_NH_lim = 0.1**: ammonia half-saturation coefficient for NH₄ nutrient limitation (mg N/l).
- **K_sulf_lim = 0.05**: sulphate half-saturation coefficient for sulphur nutrient limitation (mg S/l).

- **i_Xsulf = 0.0021**: mass S/mass COD in biomass.
- **N2O_frac_denitri = 0.0005**: mass N₂O-N produced/mass NO₃-N denitrified.
- **K_sulf = 0.5**: half-saturation coefficient for sulphate reducing bacteria (mg S/l).

The parameters above are gathered in the parameter vector (spASAnox-DEF) in `spInit.m` and included as an argument in `spASAnoxModel.m` when calling the actual anoxic reactor model.

The complete source code for the model is available in Appendix O. The code is somewhat different than what was used for the previously discussed m-file models. The anoxic model (as well as the aerobic model) is based on about 25 active differential equations and these must be solved using a numerical solver, such as Matlab's `ode15s`. To enhance the performance of the simulations these two models are therefore written as an Matlab S-function, which can be executed from within Simulink and drastically improves the performance compared to if the model was written as a normal m-file. The code must obviously follow the formal rules of how an S-function is written, e.g. init section, derivative section, output section.

The dynamics of the model is described by the following processes. Only the principles are shortly stated below and for details the source code should be examined.

1. *Aerobic growth of Heterotrophs*. The organisms require readily biodegradable substrate, oxygen, ammonia, phosphate, potassium and sulphate, which together defines the actual growth rate of the organisms by a series a of switching functions.
2. *Anoxic growth of Heterotrophs*. The organisms require readily biodegradable substrate, lack of oxygen, nitrate, phosphate, potassium and sulphate, which together defines the actual growth rate of the organisms by a series a of switching functions.
3. *Growth of Autotrophs*. The organisms require oxygen, ammonia, phosphate, potassium and sulphate, which together defines the actual growth rate of the organisms by a series a of switching functions.
4. *Decay of Heterotrophs*. The decay rate is considered lower for anoxic conditions compared to aerobic conditions.
5. *Decay of Autotrophs*. The decay rate is considered lower for anoxic conditions compared to aerobic conditions.
6. *Ammonification*. Requires soluble organic nitrogen. Performed by Heterotrophs.
7. *Hydrolysis of slowly biodegradable substrate*. In principle defined by the ratio of slowly biodegradable substrate to Heterotrophs. Active in both anoxic and aerobic conditions at different rates.
8. *Hydrolysis of particulate organic nitrogen*. Same principle as process 7 but based on the ratio of particulate organic nitrogen to Heterotrophs.
9. *Hydrolysis of particulate organic phosphorus*. Same principle as process 7 but based on the ratio of particulate organic phosphorus to Heterotrophs.

10. *Oxidation of sulphide*. Spontaneous reaction in aerobic conditions. Similar rate as ammonification.

11. *Growth of Heterotrophs from sulphate reduction*. Inhibited in anoxic and aerobic condition (i.e. only takes place if no oxygen or nitrate is available), assumed that 50% of the organisms that can denitrify can also use this metabolic pathway. The organisms require readily biodegradable substrate, phosphate, potassium and sulphate, which together defines the actual growth rate of the organisms by a series of switching functions.

The above processes are then combined to form the differential equations based on the set of stoichiometric parameters defined in spASAnoxDEF. More stoichiometric parameters are calculated within the model, hidden from the user. The model also calculates the produced nitrogen gas and carbon dioxide and the consumption of oxygen (if present). The model assumes all produced nitrogen gas and carbon dioxide is released into air. The default value for oxygen concentration in the anoxic reactor is set to zero even to a small fraction of oxygen may enter the system via the influent and recirculation streams. The effluent concentrations of BOD, TSS and VS are calculated based on the user defined conversion factors in spASAnoxPAR.

An external carbon source can be added to the wastewater by the user by setting parameters in spASAnoxPAR. An external carbon source is assumed to contain readily biodegradable COD, e.g. methanol, ethanol, acetate. The small flow change due to such an addition is neglected.

As a purely empirical reaction the amount of produced N_2O is also calculated. This is simply done by assuming that a small fraction of the denitrified NO_3 does not lead to nitrogen gas production but rather produce N_2O . If no knowledge of N_2O production exists the parameter **N2O_frac_denitri** should be set to zero. At this stage the N_2O production is assumed to be released into the air rather than dissolved in the water phase. In reality the produced N_2O may only be partly stripped in the anoxic reactor but also in other parts of the plant, in particular in aerated reactors. However, it is easier for a potential user to consider that the N_2O has been released into air and not have to remember that any N_2O released in other modules may partly have been created in the anoxic reactor. Any results in relation to the formation of N_2O is highly questionable.

A significant number of validity checks are implemented within the model to warn the user about any inconsistencies, problems or errors detected.

Nine extra variables are given in the output vector:

- Added carbon source (kg COD/year);
- Oxygen consumption (kg COD/year year = kg O_2 /year);
- Carbon dioxide production (kg CO_2 /year);
- Nitrogen gas production (kg N_2 /year);
- N_2O production (kg N_2O /year);
- Total energy usage (J/year).

- Energy used for mixing (J/year).
- Energy used for pumping (J/year).
- Energy used for aeration (J/year).

The oxygen, carbon dioxide and nitrogen outputs are calculated based on the stoichiometric relationships within the model.

The energy usage is divided into three sub-categories and based on several assumptions. Energy use is normally calculated in relation to influent flow so that the energy use automatically adjusts to plants of different sizes and different layouts of the same plant. The energy for pumping for any internal recirculation (if it exists) is set to 20 Wh/m³ of the recycled flow (72000 J/m³). This pumping energy is 40% of what has been considered for pumping in previous models. The reason for this difference is that with a good plant layout an internal recirculation can be accomplished more efficiently. The energy used for mixing is calculated in a different way. It is not reasonable to make this energy consumption proportional to influent flow. Instead it is the volume that requires mixing that is essential. Otherwise the anoxic reactor would require the same amount of energy for mixing regardless of 5 or 55% of the biological reactor volume was defined to be anoxic (if the same influent wastewater flow was used). Therefore we define a power consumption instead, the default value is set to 2.5 W/m³ of anoxic reactor volume (see also Chapter 9). The third category for energy is related to aeration but this is normally set to zero in the anoxic model. The different energy categories are then added together and given as a total energy output variable from the model.

In order to account for the different energy efficiencies for small and large plants a special function is used by which all energy values are multiplied in all models. The shape of this function is defined by the user and simply represents the fact that the energy requirements for a small plant is normally higher than that of a large plant per m³ of treated wastewater since large electrical drives are normally more efficient than small ones. The energy adjustment function is further discussed in Chapter 9. The values suggested for the three spASAnoxEnergy parameters represent the situation at a large and energy-efficient WWTP.

To demonstrate the general behaviour of the model as a stand-alone model (i.e. only an anoxic reactor without any other parts that usually make up an activated sludge process), a simulation case is presented below. The contents of the influent wastewater to the anoxic reactor are almost identical to the contents of the effluent wastewater from Case 6.1 in Section 6.1 – transformation of influent wastewater vector. The only difference is that the concentration of nitrate has been increased by 15 mg NO₃-N/l in order to see the effects of denitrification and the ammonia concentration has been reduced with the same amount. To allow for a reasonable growth-time of organisms the hydraulic retention time of the anoxic reactor is set to one day = 24 h (i.e. a very large reactor volume). This is necessary since the reactor model is simulated on its own without an associated settler. The model parameters are chosen according to the values defined earlier in this section and no external carbon source is added and no recirculation

flows are active. The reason for the increased ammonia concentration in the output is due to the very high influent S_{ND} concentration in combination with a high retention time. More than 80% of the soluble organic nitrogen is ammonified in the anoxic reactor and only limited amounts of ammonia are consumed in the reactor due to biomass growth. The energy adjustment function is disabled.

Case 6.2: Simulation of a stand-alone anoxic reactor model.

Influent wastewater to anoxic reactor

BOD7 = 96.8394 g/m³; 159051.9885 kg/y; 21.7879 g/cap.day
 COD total = 195.4415 g/m³; 320999.2011 kg/y; 43.9725 g/cap.day
 COD biosol = 105.2091 g/m³; 172798.7786 kg/y; 23.6711 g/cap.day
 COD insol = 29.9957 g/m³; 49265.8225 kg/y; 6.7487 g/cap.day
 COD biopart = 40.0337 g/m³; 65752.6 kg/y; 9.0072 g/cap.day
 COD inpart = 20.203 g/m³; 33182 kg/y; 4.5455 g/cap.day
 COD slowly biodeg part = 39.9937 g/m³; 65686.8474 kg/y; 8.9982 g/cap.day
 COD Heterotrophs = 0.03603 g/m³; 59.1773 kg/y; 0.0081065 g/cap.day
 COD Autotrophs = 0.0040034 g/m³; 6.5753 kg/y; 0.00090072 g/cap.day
 Sum of COD-fractions = 320999.2011 kg/y

Volatile solids (VS) = 128.704 g/m³; 211387.5194 kg/y; 28.9572 g/cap.day
 Suspended solids (TSS) = 44.9623 g/m³; 73847.4571 kg/y; 10.1161 g/cap.day
 Dissolved solids (TS-TSS) = 769.7444 g/m³; 1264252.2215 kg/y; 173.1852 g/cap.day
 Fixed solids (TS-VS) = 686.0026 g/m³; 1126712.1592 kg/y; 154.3441 g/cap.day
 Total solids (TS) = 814.7067 g/m³; 1338099.6786 kg/y; 183.3013 g/cap.day
 H₂O = 1641093140.9038 kg/y; 224.8073 kg/cap.day
 Total volume = 1642431.2406 m³/y; 4499.8116 m³/day
 VS content = 0.01287 %
 TSS content = 0.0044962 %
 TS content = 0.081471 %

Total nitrogen = 80.2949 g/m³; 131878.8692 kg/y; 18.0656 g/cap.day
 N-NH₃ & N-NH₄ = 36.9955 g/m³; 60762.6386 kg/y; 8.3236 g/cap.day
 N-NO₃ = 15.0723 g/m³; 24755.2434 kg/y; 3.3911 g/cap.day
 N-N₂O = 0 g/m³; 0 kg/y; 0 g/cap.day
 N-org,part not Xnd = 1.0121 g/m³; 1662.3775 kg/y; 0.22772 g/cap.day
 N-org,sol not Snd = 2.1884 g/m³; 3594.231 kg/y; 0.49236 g/cap.day
 N-org, Snd = 23.0269 g/m³; 37820.0562 kg/y; 5.1808 g/cap.day
 N-org Xnd = 1.9997 g/m³; 3284.3225 kg/y; 0.44991 g/cap.day
 Sum of N-fractions = 131878.8692 kg/y

Total sulphur = 4.1151 g/m³; 6758.7547 kg/y; 0.92586 g/cap.day
 SO₄-S = 2.654 g/m³; 4359.0365 kg/y; 0.59713 g/cap.day
 S particulate,bio = 0.089014 g/m³; 146.2001 kg/y; 0.020027 g/cap.day
 Sulfide HS-S = 1.327 g/m³; 2179.5182 kg/y; 0.29856 g/cap.day
 S particulate,inert = 0.045055 g/m³; 73.9999 kg/y; 0.010137 g/cap.day
 Sum of S-fractions = 6758.7547 kg/y

Total phosphorus = 2.5227 g/m³; 4143.3699 kg/y; 0.56758 g/cap.day
 PO₄-P = 1.9997 g/m³; 3284.3699 kg/y; 0.44991 g/cap.day
 P particulate not Xpn = 0.17576 g/m³; 288.6737 kg/y; 0.039544 g/cap.day
 P part Xpn = 0.34725 g/m³; 570.3263 kg/y; 0.078127 g/cap.day
 Sum of P-fractions = 4143.3699 kg/y

The URWARE Wastewater Treatment Plant Models

Total potassium = 18.9068 g/m³; 31053.1308 kg/y; 4.2539 g/cap.day
Dissolved potassium = 18.8068 g/m³; 30888.8808 kg/y; 4.2314 g/cap.day
Organically bound potassium = 0.1 g/m³; 164.25 kg/y; 0.0225 g/cap.day
Temperature in water = 20 degC

Effluent wastewater from the anoxic reactor

BOD7 = 64.2877 g/m³; 105588.1061 kg/y; 14.4641 g/cap.day
COD total = 150.8186 g/m³; 247709.2098 kg/y; 33.9328 g/cap.day
COD biosol = 17.2847 g/m³; 28388.8514 kg/y; 3.8889 g/cap.day
COD insol = 29.9957 g/m³; 49265.8225 kg/y; 6.7487 g/cap.day
COD biopart = 81.6195 g/m³; 134054.3888 kg/y; 18.3636 g/cap.day
COD inpart = 21.9188 g/m³; 36000.1472 kg/y; 4.9315 g/cap.day
COD slowly biodeg part = 12.4295 g/m³; 20414.5842 kg/y; 2.7965 g/cap.day
COD Heterotrophs = 69.1862 g/m³; 113633.6403 kg/y; 15.5663 g/cap.day
COD Autotrophs = 0.0037532 g/m³; 6.1643 kg/y; 0.00084443 g/cap.day
Sum of COD-fractions = 247709.2098 kg/y

Volatile solids (VS) = 96.9742 g/m³; 159273.4741 kg/y; 21.8183 g/cap.day
Suspended solids (TSS) = 88.0322 g/m³; 144586.8726 kg/y; 19.8064 g/cap.day
Dissolved solids (TS-TSS) = 726.6744 g/m³; 1193512.806 kg/y; 163.4949 g/cap.day
Fixed solids (TS-VS) = 717.7325 g/m³; 1178826.2045 kg/y; 161.483 g/cap.day
Total solids (TS) = 814.7067 g/m³; 1338099.6786 kg/y; 183.3013 g/cap.day
H2O = 1641093140.9038 kg/y; 224.8073 kg/cap.day
Total volume = 1642431.2406 m³/y; 4499.8116 m³/day
VS content = 0.0096974 %
TSS content = 0.0088032 %
TS content = 0.081471 %

Total nitrogen = 66.2143 g/m³; 108752.361 kg/y; 14.8976 g/cap.day
N-NH₃ & N-NH₄ = 51.2166 g/m³; 84119.7735 kg/y; 11.5233 g/cap.day
N-NO₃ = 0.99166 g/m³; 1628.7353 kg/y; 0.22311 g/cap.day
N-N₂O = 0 g/m³; 0 kg/y; 0 g/cap.day
N-org,part not Xnd = 7.062 g/m³; 11598.8348 kg/y; 1.5889 g/cap.day
N-org,sol not Snd = 2.1884 g/m³; 3594.231 kg/y; 0.49236 g/cap.day
N-org, Snd = 3.977 g/m³; 6532.0091 kg/y; 0.8948 g/cap.day
N-org Xnd = 0.77859 g/m³; 1278.7773 kg/y; 0.17517 g/cap.day
Sum of N-fractions = 108752.361 kg/y

Total sulphur = 4.1151 g/m³; 6758.7547 kg/y; 0.92586 g/cap.day
SO₄-S = 0.28766 g/m³; 472.4656 kg/y; 0.064721 g/cap.day
S particulate,bio = 0.23423 g/m³; 384.7056 kg/y; 0.052699 g/cap.day
Sulfide HS-S = 3.5445 g/m³; 5821.6655 kg/y; 0.79749 g/cap.day
S particulate,inert = 0.048658 g/m³; 79.9181 kg/y; 0.010948 g/cap.day
Sum of S-fractions = 6758.7547 kg/y

Total phosphorus = 2.5227 g/m³; 4143.3699 kg/y; 0.56758 g/cap.day
PO₄-P = 0.78882 g/m³; 1295.5877 kg/y; 0.17748 g/cap.day
P particulate not Xpn = 1.5759 g/m³; 2588.3362 kg/y; 0.35457 g/cap.day
P part Xpn = 0.15796 g/m³; 259.4459 kg/y; 0.035541 g/cap.day
Sum of P-fractions = 4143.3699 kg/y

Total potassium = 18.9068 g/m³; 31053.1308 kg/y; 4.2539 g/cap.day
Dissolved potassium = 17.4238 g/m³; 28617.3998 kg/y; 3.9202 g/cap.day
Organically bound potassium = 1.483 g/m³; 2435.731 kg/y; 0.33366 g/cap.day
Temperature in water = 20 degC

Extra output variables from the anoxic reactor

Added carbon source = 0 kg COD/y; 0 kg COD/cap.y; 0 kg COD/day; 0 kg COD/cap.day
 Total oxygen into system = 0 kg O₂/y; 0 kg O₂/cap.y; 0 kg O₂/day; 0 kg O₂/cap.day
 CO₂ production = 103991.1382 kg CO₂/y; 5.1996 kg CO₂/cap.y; 284.9072 kg CO₂/day; 0.014245 kg CO₂/cap.day
 N₂ production = 23114.9449 kg N₂/y; 1.1557 kg N₂/cap.y; 63.3286 kg N₂/day; 0.0031664 kg N₂/cap.day
 N₂O production = 18.1708 kg N₂O/y; 0.00090854 kg N₂O/cap.y; 0.049783 kg N₂O/day; 2.4892e-06 kg N₂O/cap.day
 Energy consumption (total) = 354.78 GJ/y; 98550.0 kWh/y
 Energy consumption (mixing) = 354.78 GJ/y; 98550.0 kWh/y
 Energy consumption (pumping) = 0 GJ/y; 0 kWh/y
 Energy consumption (aeration) = 0 GJ/y; 0 kWh/y

In order to demonstrate that the behaviour of the anoxic model is reasonable, a comparative simulation is done with the general wastewater treatment plant simulator GPS-X (Hydromantis, 1999). The GPS-X model (default ASM1 using the same set of model parameters) is simulated according to the same principles. The influent wastewater is characterised similar to the URWARE input (although not as many variables are described in GPS-X). We can see that the results are similar to the URWARE results.

Influent wastewater (from GPS-X, URWARE inputs within parenthesis)

BOD₇ = 97.3 g/m³ (96.8)
 COD total = 195.4 g/m³ (195.4)
 COD biodegradable_soluble = 105.2 g/m³ (105.2)
 COD sol_inert = 30 g/m³ (30)
 COD slowly biodeg part = 40.0 g/m³ (40.0)
 COD part_inert = 20.2 g/m³ (20.2)
 COD Heterotrophs = 0.036 g/m³ (0.036)
 COD Autotrophs = 0.004 g/m³ (0.004)

Volatile suspended solids (VSS) = 38.8 g/m³ (not used in URWARE but a backward calculation indicates a value of about 38.8 g/m³)
 Suspended solids (TSS) = 45.0 g/m³ (45.0)
 Flow rate = 4500 m³/d (4500)
 VSS content = 0.0039 % (not used in URWARE but 0.0039%)
 TSS content = 0.0045 % (0.0045)

Total nitrogen = 77.1 g/m³ (80.3)
 N-NH₃ & N-NH₄ = 37 g/m³ (37)
 N-NO₃ = 15.1 g/m³ (15.1)
 N-org,part not Xnd = ??? g/m³ (1.0) not described in ASM1
 N-org,sol not Snd = ??? g/m³ (2.2) not described in ASM1
 N-org, Snd = 23.0 g/m³ (23.0)
 N-org, Xnd = 2 g/m³ (2)

Effluent wastewater (from GPS-X, URWARE results (Case 6.2) within parenthesis)

BOD₇ = 65.9 g/m³ (64.3)
 COD total = 153.0 g/m³ (150.8)
 COD biodegradable_soluble = 19.1 g/m³ (17.3)
 COD sol_inert = 30 g/m³ (30)
 COD slowly biodeg part = 19.1 g/m³ (12.4)
 COD part_inert = 21.7 g/m³ (21.9)
 COD Heterotrophs = 63.1 g/m³ (69.2)
 COD Autotrophs = 0.004 g/m³ (0.004)

Volatile suspended solids (VSS) = 66.9 g/m³ (not used in URWARE but a backward calculation indicates a value of about 68.9 g/m³)
 Suspended solids (TSS) = 77.8 g/m³ (88.0)
 Flow rate = 4500 m³/d (4500)
 VSS content = 0.0067 % (not used in URWARE but 0.0069%)
 TSS content = 0.0078 % (0.0088)

Total nitrogen = 57.1 g/m³ (66.2)
 N-NH₃ & N-NH₄ = 51.1 g/m³ (51.2)
 N-NO₃ = 0.66 g/m³ (0.99)
 N-org,part not Xnd = ??? g/m³ (7.1) not described in ASM1
 N-org,sol not Snd = ??? g/m³ (2.2) not described in ASM1
 N-org, Snd = 4.2 g/m³ (4.0)
 N-org, Xnd = 1.2 g/m³ (0.78)

N₂ production = 22338 kg N₂/y (23114)

The results are similar in the two implementations. Some differences depend on the capability of the URWARE to reduce sulphate once the nitrate concentration is sufficiently low. The reason for the difference in total nitrogen is because some nitrogen fractions are not modelled by ASM1 (as used in GPS-X), which is indicated by ??? above. Moreover, there appears to be small error in the GPS-X implementation (version 2.4 for Solaris) since the concentrations of readily and slowly biodegradable substrates have identical values and their dynamics are identical in the GPS-X simulation.

6.3 Aerobic bioreactor

The aerobic model is a fully dynamic model based on the ASM1 approach but with many modifications in order to account for the types of substances not accounted for in ASM1 (phosphorus, sulphur, potassium, etc.). The principles of this model are identical to the anoxic model. Switching functions (Monod-type functions) are used to determine whether the model behaves in an anoxic fashion or aerobic fashion. Basically it is only the calculations of the extra output variables that differ between the models, i.e. energy usage and other special outputs. The model is constructed to work together with an anoxic model and the ideal settler model to describe the behaviour of an activated sludge process. However, it can also be used as a fully dynamic stand-alone model. By connecting the different recirculation flows in the fashion desired by the user, the system can describe predenitrification systems, postdenitrification system, simple COD removal plants, COD removal plants with nitrification, etc. The volume of wastewater in the reactor is always considered to be constant and calculated based on the influent flow rate to the AS stage and the user defined parameters setting the aerobic volume fraction and the hydraulic retention time of the bioreactors. Complete mix is also assumed. The model makes use of the global variable spASVolumeIn, which was defined in the previous subsection.

The behaviour of the aerobic reactor model is influenced by 14 parameters defined by the user. Note that several of these parameters are common for both the anoxic and the aerobic models as they must be known to both modules when they are connected via recirculations (see Figures 8.2 and

8.3). These parameters are defined in the main initialisation file for the WWTP-model (`spInit.m`). The parameters are:

- **spASHydRetTime**: total hydraulic nominal retention time for AS reactors in days (anox + aerob volume).
- **spASAerobFrac**: fraction of total reactor volume that is aerobic.
- **spASAerobSOlevel**: requested oxygen concentration in aerobic reactor (mg/l).
- **spASAerobIntRecFrac**: recycle expressed as the fraction of influent flow recycled internally from the aerobic reactor to some other process ($Q_{intr} = Q_{in} * \text{spASAerobIntRecFrac}$).
- **spCODtoBOD**: conversion factor for calculating BOD_7 from COD_biodegradable. Suggested value 0.65 mg BOD_7 /mg COD_biodegradable.
- **spCODtoVS(1,1)**: conversion factor for calculating volatile solids (VS) from biodegradable COD. Suggested value $1/1.42 \approx 0.704$ (Metcalf & Eddy, 1991).
- **spCODtoVS(2,1)**: conversion factor for calculating volatile solids (VS) from inert COD. Suggested value $1/1.9 \approx 0.526$.
- **spCODtoSS(1,1)**: conversion factor for calculating suspended solids (SS) from biodegradable and inert particulate COD. Suggested value 0.75 g SS/g COD.
- **spCODtoSS(2,1)**: conversion factor for calculating suspended solids (SS) from biomass COD. Suggested value 0.9 g SS/g COD.
- **spASAerobAirEff**: mass of O_2 dissolved in water/mass of O_2 put into system for pure water, i.e. no biological activity. Suggested value 0.67 (huge simplification, used for energy calculations).
- **spASSludgeAge**: requested AS sludge age in days (anox + aerob volume).
- **spASAerobEnergy(1,1)**: energy required for mixing (in case of intermittent aeration). Suggested value 2.5 W/m³ of aerobic reactor volume.
- **spASAerobEnergy(2,1)**: energy required for pumping of any recirculation flows. Suggested value 72000 J/m³ (20 Wh/m³) of pumped flow.
- **spASAerobEnergy(3,1)**: energy required for aeration. Suggested value 1800000 J/kg O_2 (500 Wh/kg O_2).

The parameters above are gathered into the input parameter vector (`spASAerobPAR`) in `spInit.m` and included as an argument in `spASAerobModel.m` when calling the actual aerobic reactor model.

Modelling of biological processes is a complex task and therefore a second set of model parameters (32) are required by the aerobic model. These parameters are also defined in the main initialisation file for the WWTP-model (`spInit.m`) and should normally not be modified by the user unless substantial modelling knowledge exists. Most parameters are common to both the anoxic and aerobic reactor models. The default values are given for 20 °C and automatically adjusted within the model for the actual wastewater temperature (by Arrhenius functions). The values represent the default values proposed for the ASM1 model (in some cases for the ASM2d model)

and the terminology established by the ASM1 is used whenever possible. As the model is based on the death-regeneration principle the values for yields, decay rates and f_P may appear different than the observed values from an actual plant. However, this effect is related to the model structure rather than a true difference between model values and observed values (see Henze *et al.*, 2000). These model parameters values can actually be converted into the equivalent observed values (see for example Section 6.4 for f_P conversion formula). The parameters are:

- $Y_A = 0.24$: autotrophic yield (g cell COD formed/g N oxidized).
- $Y_H = 0.67$: heterotrophic yield (g cell COD formed/g COD oxidized).
- $f_P = 0.08$: fraction of biomass ending up as inert particulate material (dimensionless).
- $i_{XB} = 0.086$: mass N/mass COD in biomass.
- $i_{XE} = 0.06$: mass N/mass COD in inert material.
- $\mu_H = 6.0$: maximum specific growth rate for Heterotrophs (day^{-1}).
- $K_S = 20$: half-saturation coefficient for heterotrophic biomass (mg COD/l).
- $K_{OH} = 0.2$: oxygen half-saturation coefficient for Heterotrophs (mg COD/l).
- $K_{NO} = 0.5$: nitrate half-saturation coefficient for denitrifying Heterotrophs (mg N/l).
- $b_{H_aerob} = 0.62$: heterotrophic decay rate in aerobic conditions (day^{-1}).
- $ny_g = 0.8$: correction factor for μ_H in anoxic conditions (dimensionless).
- $ny_h = 0.4$: correction factor for hydrolysis in anoxic conditions (dimensionless).
- $k_h = 3.0$: maximum specific hydrolysis rate (mass slowly biodegradable COD/(mass cell COD * day)).
- $K_X = 0.03$: half-saturation coefficient for hydrolysis (mass slowly biodegradable COD/mass cell COD).
- $\mu_A = 0.8$: max specific growth rate for Autotrophs.
- $K_{NH} = 1$: ammonia half-saturation coefficient for Autotrophs (mg N/l), i.e. NH_4 = substrate.
- $K_{OA} = 0.4$: oxygen half-saturation coefficient for Autotrophs (mg COD/l).
- $k_a = 0.08$: ammonification rate ($\text{mg COD} * \text{day}^{-1}$).
- $b_{A_aerob} = 0.2$: autotrophic decay rate in aerobic conditions (day^{-1}).
- $K_P = 0.05$: phosphate half-saturation coefficient for microbial growth (mg P/l).
- $i_{XBP} = 0.02$: mass P/mass COD in biomass.
- $i_{XEP} = 0.01$: mass P/mass COD in inert material.
- $K_K = 0.05$: potassium half-saturation coefficient for microbial growth (mg K/l).

- **i_XBK = 0.02**: mass K/mass COD in biomass.
- **i_XEK = 0.0**: mass K/mass COD in inert material.
- **b_H_anox = b_H_aerob/2**: heterotrophic decay rate in anoxic conditions (day^{-1}).
- **b_A_anox = b_A_aerob/3**: autotrophic decay rate in anoxic conditions (day^{-1}).
- **K_NH_lim = 0.1**: ammonia half-saturation coefficient for NH_4 nutrient limitation (mg N/l).
- **K_sulf_lim = 0.05**: sulphate half-saturation coefficient for sulphur nutrient limitation (mg S/l).
- **i_Xsulf = 0.0021**: mass S/mass COD in biomass.
- **N2O_frac_nitri = 0.0003**: mass N_2O -N produced/mass NO_3 -N denitrified.
- **K_sulf = 0.5**: half-saturation coefficient for sulphate reducing bacteria (mg S/l).

The parameters above are gathered in the parameter vector (spASAerob-DEF) in `spInit.m` and included as an argument in `spASAerobModel.m` when calling the actual aerobic reactor model.

The complete source code for the model is available in Appendix P. The code is somewhat different than what was used for the previously discussed m-file models. The aerobic model (as well as the anoxic model) is based on about 25 active differential equations and these must be solved using a numerical solver, such as Matlab's `ode15s`. To enhance the performance of the simulations these two models are therefore written as an Matlab S-function, which can be executed from within Simulink and drastically improves the performance compared to if the model was written as a normal m-file. The code must obviously follow the formal rules of how an S-function is written, e.g. `init` section, `derivative` section, `output` section.

The dynamics of the model is described by the following processes. Only the principles are shortly stated below and for details the source code should be examined.

1. *Aerobic growth of Heterotrophs*. The organisms require readily biodegradable substrate, oxygen, ammonia, phosphate, potassium and sulphate, which together defines the actual growth rate of the organisms by a series a of switching functions.
2. *Anoxic growth of Heterotrophs*. The organisms require readily biodegradable substrate, lack of oxygen, nitrate, phosphate, potassium and sulphate, which together defines the actual growth rate of the organisms by a series a of switching functions.
3. *Growth of Autotrophs*. The organisms require oxygen, ammonia, phosphate, potassium and sulphate, which together defines the actual growth rate of the organisms by a series a of switching functions.
4. *Decay of Heterotrophs*. The decay rate is considered lower for anoxic conditions compared to aerobic conditions.
5. *Decay of Autotrophs*. The decay rate is considered lower for anoxic

conditions compared to aerobic conditions.

6. *Ammonification*. Requires soluble organic nitrogen. Performed by Heterotrophs.
7. *Hydrolysis of slowly biodegradable substrate*. In principle defined by the ratio of slowly biodegradable substrate to Heterotrophs. Active in both anoxic and aerobic conditions at different rates.
8. *Hydrolysis of particulate organic nitrogen*. Same principle as process 7 but based on the ratio of particulate organic nitrogen to Heterotrophs.
9. *Hydrolysis of particulate organic phosphorus*. Same principle as process 7 but based on the ratio of particulate organic phosphorus to Heterotrophs.
10. *Oxidation of sulphide*. Spontaneous reaction in aerobic conditions. Similar rate as ammonification.
11. *Growth of Heterotrophs from sulphate reduction*. Inhibited in anoxic and aerobic condition, assumed that 50% of the organisms that can denitrify can also use this metabolic pathway. The organisms require readily biodegradable substrate, phosphate, potassium and sulphate, which together defines the actual growth rate of the organisms by a series of switching functions.

The above processes are then combined to form the differential equations based on the set of stoichiometric parameters defined in spASAerobDEF. More stoichiometric parameters are calculated within the model, hidden from the user. The model also calculates the produced nitrogen gas and carbon dioxide and the consumption of oxygen. The model assumes all produced nitrogen gas and carbon dioxide is released into air. The value for oxygen concentration in the aerobic reactor is set via the parameter **spASAerobSOlevel** to a suitable value (usually between 1.5 and 3.5 mg O₂/l). The model assumes that ideal local controllers are available to maintain the oxygen concentration at the requested level. The effluent concentrations of BOD, TSS and VS are calculated based on the user defined conversion factors in spASAerobPAR.

As a purely empirical reaction the amount of produced N₂O is also calculated. This is simply done by assuming that a small fraction of the nitrified NH₄ (i.e. not the ammonia required as a nutrient but only the part that actually nitrifies) does not lead to nitrate production but rather produce N₂O. If no knowledge of N₂O production exists the parameter **N2O_frac_nitri** should be set to zero. At this stage the N₂O production is assumed to be completely stripped from the water phase by the aeration and released into air. In the anoxic reactor all *produced* N₂O was released into air but any N₂O already dissolved in the influent wastewater remained there. In the aerobic reactor both the produced N₂O and the already dissolved N₂O is considered to be stripped into air. Consequently, the N₂O-output variable defined below may contain both produced N₂O and already present but now stripped N₂O. The user should be aware of this. However, any results in relation to this reaction is highly questionable.

A significant number of validity checks are implemented within the model

to warn the user about any inconsistencies, problems or errors detected.

Nine extra variables are provided as part of the output vector:

- Oxygen consumption by direct biological activity (kg COD/year = kg O₂/year).
- Total oxygen consumption including loss and water (kg COD/year = kg O₂/year);
- Carbon dioxide production (kg CO₂/year);
- Nitrogen gas production (kg N₂/year);
- N₂O production (kg N₂O/year);
- Total energy usage (J/year).
- Energy used for mixing (J/year).
- Energy used for pumping (J/year).
- Energy used for aeration (J/year).

The oxygen, carbon dioxide and nitrogen outputs are calculated based on the stoichiometric relationships within the model. The oxygen consumption is given as two values: the oxygen consumed directly in the biological reactions and the total amount of oxygen used by the system including oxygenation of water and aeration efficiency (losses due to incomplete solution of air into water phase).

The energy usage is divided into three sub-categories and based on several assumptions. Energy use is normally calculated in relation to influent flow so that the energy use automatically adjusts to plants of different sizes and different layouts of the same plant. The energy for pumping for any internal recirculation (if it exists) is set to 20 Wh/m³ of the recycled flow (72000 J/m³). This pumping energy is 40% of what has been considered for pumping in previous models. The reason for this difference is that with a good plant layout an internal recirculation can be accomplished more efficiently. The energy used for mixing in the aerobic zone is by default set to zero as it is assumed that the biomass is kept in suspension by the aeration and no mechanical mixing is required. The third category for energy is related to aeration. To calculate the aeration energy we base this on the total amount of oxygen required by the system, i.e. to oxygenate the water to the requested concentration (if there was no biological activity) and the oxygen that is lost by the system and realised into air. The user sets the parameter **spASAerobAirEff** to define the percentage of input oxygen that actually dissolves in the water phase. The remaining part is released into the air. The default value for this parameter is 67% but it is highly uncertain. It is assumed that 500 Wh/kg O₂ is required for the aeration system (1.8 MJ/kg O₂). Moreover, the efficiency is in reality associated with a large number of factors (e.g. type of aeration system, temperature, requested oxygen concentration, water characteristics). It would be possible to create a reasonable model for the aeration efficiency, however, the intended purpose of the overall URWARE software does not motivate the extra complexity. The different energy categories are then added together and given as a total energy output variable from the model.

In order to account for the different energy efficiencies for small and large plants a special function is used by which all energy values are multiplied in all models. The shape of this function is defined by the user and simply represents the fact that the energy requirements for a small plant is normally higher than that of a large plant per m³ of treated wastewater since large electrical drives are normally more efficient than small ones. The energy adjustment function is further discussed in Chapter 9. The values suggested for the three spASAerobEnergy parameters represent the situation at a large and energy-efficient WWTP.

To demonstrate the general behaviour of the model as a stand-alone model (i.e. only an aerobic reactor without any other parts that usually make up an activated sludge process), a simulation case is presented below. The contents of the influent wastewater to the aerobic reactor are identical to the contents of the effluent wastewater from Case 6.2 in Section 6.2 – simulation of stand-alone anoxic reactor (i.e. the aerobic reactor could be considered part of predenitrifying system although without a settler or any recycled flows). To allow for a reasonable growth-time of organisms the hydraulic retention time of the aerobic reactor is set to eight days (i.e. a huge reactor volume). This is necessary since the reactor model is simulated on its own without an associated settler and the low growth rate of Autotrophs (nitrification) is limiting the system. The model parameters are chosen according to the values defined earlier in this section (obviously there are no active recirculations). The dissolved oxygen concentration in the reactor is set to 2 mg/l.

Case 6.3: Simulation of a stand-alone aerobic reactor model.

Influent wastewater to aerobic reactor

BOD7 = 64.2877 g/m³; 105588.1061 kg/y; 14.4641 g/cap.day
 COD total = 150.8186 g/m³; 247709.2098 kg/y; 33.9328 g/cap.day
 COD biosol = 17.2847 g/m³; 28388.8514 kg/y; 3.8889 g/cap.day
 COD insol = 29.9957 g/m³; 49265.8225 kg/y; 6.7487 g/cap.day
 COD biopart = 81.6195 g/m³; 134054.3888 kg/y; 18.3636 g/cap.day
 COD inpart = 21.9188 g/m³; 36000.1472 kg/y; 4.9315 g/cap.day
 COD slowly biodeg part = 12.4295 g/m³; 20414.5842 kg/y; 2.7965 g/cap.day
 COD Heterotrophs = 69.1862 g/m³; 113633.6403 kg/y; 15.5663 g/cap.day
 COD Autotrophs = 0.0037532 g/m³; 6.1643 kg/y; 0.00084443 g/cap.day
 Sum of COD-fractions = 247709.2098 kg/y

Volatile solids (VS) = 96.9742 g/m³; 159273.4741 kg/y; 21.8183 g/cap.day
 Suspended solids (TSS) = 88.0322 g/m³; 144586.8726 kg/y; 19.8064 g/cap.day
 Dissolved solids (TS-TSS) = 726.6744 g/m³; 1193512.806 kg/y; 163.4949 g/cap.day
 Fixed solids (TS-VS) = 717.7325 g/m³; 1178826.2045 kg/y; 161.483 g/cap.day
 Total solids (TS) = 814.7067 g/m³; 1338099.6786 kg/y; 183.3013 g/cap.day
 H2O = 1641093140.9038 kg/y; 224.8073 kg/cap.day
 Total volume = 1642431.2406 m³/y; 4499.8116 m³/day
 VS content = 0.0096974 %
 TSS content = 0.0088032 %
 TS content = 0.081471 %

The URWARE Wastewater Treatment Plant Models

Total nitrogen = 66.2213 g/m³; 108763.9243 kg/y; 14.8992 g/cap.day
N-NH₃ & N-NH₄ = 51.2166 g/m³; 84119.7735 kg/y; 11.5233 g/cap.day
N-NO₃ = 0.99166 g/m³; 1628.7353 kg/y; 0.22311 g/cap.day
N-N₂O = 0.0070403 g/m³; 11.5633 kg/y; 0.001584 g/cap.day
N-org,part not Xnd = 7.062 g/m³; 11598.8348 kg/y; 1.5889 g/cap.day
N-org,sol not Snd = 2.1884 g/m³; 3594.231 kg/y; 0.49236 g/cap.day
N-org, Snd = 3.977 g/m³; 6532.0091 kg/y; 0.8948 g/cap.day
N-org Xnd = 0.77859 g/m³; 1278.7773 kg/y; 0.17517 g/cap.day
Sum of N-fractions = 108763.9243 kg/y

Total sulphur = 4.1151 g/m³; 6758.7547 kg/y; 0.92586 g/cap.day
SO₄-S = 0.28766 g/m³; 472.4656 kg/y; 0.064721 g/cap.day
S particulate,bio = 0.23423 g/m³; 384.7056 kg/y; 0.052699 g/cap.day
Sulfide HS-S = 3.5445 g/m³; 5821.6655 kg/y; 0.79749 g/cap.day
S particulate,inert = 0.048658 g/m³; 79.9181 kg/y; 0.010948 g/cap.day
Sum of S-fractions = 6758.7547 kg/y

Total phosphorus = 2.5227 g/m³; 4143.3699 kg/y; 0.56758 g/cap.day
PO₄-P = 0.78882 g/m³; 1295.5877 kg/y; 0.17748 g/cap.day
P particulate not Xpn = 1.5759 g/m³; 2588.3362 kg/y; 0.35457 g/cap.day
P part Xpn = 0.15796 g/m³; 259.4459 kg/y; 0.035541 g/cap.day
Sum of P-fractions = 4143.3699 kg/y

Total potassium = 18.9068 g/m³; 31053.1308 kg/y; 4.2539 g/cap.day
Dissolved potassium = 17.4238 g/m³; 28617.3998 kg/y; 3.9202 g/cap.day
Organically bound potassium = 1.483 g/m³; 2435.731 kg/y; 0.33366 g/cap.day
Temperature in water = 20 degC

Effluent wastewater from the aerobic reactor

BOD₇ = 25.6096 g/m³; 42061.9702 kg/y; 5.7619 g/cap.day
COD total = 104.6488 g/m³; 171878.3977 kg/y; 23.545 g/cap.day
COD biosol = 2.0264 g/m³; 3328.2047 kg/y; 0.45592 g/cap.day
COD insol = 29.9957 g/m³; 49265.8225 kg/y; 6.7487 g/cap.day
COD biopart = 37.373 g/m³; 61382.5187 kg/y; 8.4086 g/cap.day
COD inpart = 35.2537 g/m³; 57901.8519 kg/y; 7.9318 g/cap.day
COD slowly biodeg part = 0.28354 g/m³; 465.6957 kg/y; 0.063794 g/cap.day
COD Heterotrophs = 31.9181 g/m³; 52423.2665 kg/y; 7.1813 g/cap.day
COD Autotrophs = 5.1713 g/m³; 8493.5564 kg/y; 1.1635 g/cap.day
Sum of COD-fractions = 171878.3977 kg/y

Volatile solids (VS) = 62.0878 g/m³; 101974.9711 kg/y; 13.9692 g/cap.day
Suspended solids (TSS) = 60.0334 g/m³; 98600.8014 kg/y; 13.507 g/cap.day
Dissolved solids (TS-TSS) = 754.6732 g/m³; 1239498.8772 kg/y; 169.7944 g/cap.day
Fixed solids (TS-VS) = 752.6188 g/m³; 1236124.7075 kg/y; 169.3322 g/cap.day
Total solids (TS) = 814.7067 g/m³; 1338099.6786 kg/y; 183.3013 g/cap.day
H₂O = 1641093140.9038 kg/y; 224.8073 kg/cap.day
Total volume = 1642431.2406 m³/y; 4499.8116 m³/day
VS content = 0.0062088 %
TSS content = 0.0060033 %
TS content = 0.081471 %

Total nitrogen = 64.5329 g/m³; 105990.9141 kg/y; 14.5193 g/cap.day
N-NH₃ & N-NH₄ = 1.0496 g/m³; 1723.8655 kg/y; 0.23615 g/cap.day
N-NO₃ = 55.317 g/m³; 90854.4028 kg/y; 12.4458 g/cap.day
N-N₂O = 0 g/m³; 0 kg/y; 0 g/cap.day
N-org,part not Xnd = 5.1014 g/m³; 8378.719 kg/y; 1.1478 g/cap.day
N-org,sol not Snd = 2.1884 g/m³; 3594.231 kg/y; 0.49236 g/cap.day
N-org, Snd = 0.85208 g/m³; 1399.488 kg/y; 0.19171 g/cap.day

The URWARE Wastewater Treatment Plant Models

N-org Xnd = 0.024481 g/m³; 40.2077 kg/y; 0.0055079 g/cap.day
Sum of N-fractions = 105990.9141 kg/y

Total sulphur = 4.1151 g/m³; 6758.7977 kg/y; 0.92586 g/cap.day
SO₄-S = 3.8715 g/m³; 6358.6817 kg/y; 0.87105 g/cap.day
S particulate,bio = 0.16682 g/m³; 273.9936 kg/y; 0.037533 g/cap.day
Sulfide HS-S = 0.00013323 g/m³; 0.21883 kg/y; 2.9976e-05 g/cap.day
S particulate,inert = 0.076657 g/m³; 125.9036 kg/y; 0.017247 g/cap.day
Sum of S-fractions = 6758.7977 kg/y

Total phosphorus = 2.5229 g/m³; 4143.7029 kg/y; 0.56763 g/cap.day
PO₄-P = 1.4499 g/m³; 2381.346 kg/y; 0.32621 g/cap.day
P particulate not Xpn = 1.0673 g/m³; 1752.9231 kg/y; 0.24013 g/cap.day
P part Xpn = 0.0057438 g/m³; 9.4338 kg/y; 0.0012923 g/cap.day
Sum of P-fractions = 4143.7029 kg/y

Total potassium = 18.9072 g/m³; 31053.7889 kg/y; 4.2539 g/cap.day
Dissolved potassium = 18.0661 g/m³; 29672.3889 kg/y; 4.0647 g/cap.day
Organically bound potassium = 0.84107 g/m³; 1381.4 kg/y; 0.18923 g/cap.day
Temperature in water = 20 degC

Extra output variables from the aerobic reactor

Biological oxygen consumption = 501115.4649 kg COD/y; 25.0558 kg COD/cap.y; 1372.9191 kg COD/day; 0.068646 kg COD/cap.day
Total oxygen into system = 752836.3096 kg O₂/y; 37.6418 kg O₂/cap.y; 2062.5652 kg O₂/day; 0.10313 kg O₂/cap.day
CO₂ production = 131077.6412 kg CO₂/y; 6.5539 kg CO₂/cap.y; 359.1168 kg CO₂/day; 0.017956 kg CO₂/cap.day
N₂ production = 2735.0699 kg N₂/y; 0.13675 kg N₂/cap.y; 7.4933 kg N₂/day; 0.00037467 kg N₂/cap.day
N₂O production = 43.3659 kg N₂O/y; 0.0021683 kg N₂O/cap.y; 0.11881 kg N₂O/day; 5.9405e-06 kg N₂O/cap.day
Energy consumption (total) = 1355105.3573 MJ/y; 376418.1548 kWh/y
Energy consumption (mixing) = 0 MJ/y; 0 kWh/y
Energy consumption (pumping) = 0 MJ/y; 0 kWh/y
Energy consumption (aeration) = 1355105.3573 MJ/y; 376418.1548 kWh/y

In order to demonstrate that the behaviour of the aerobic model is reasonable, a comparative simulation is done with the general wastewater treatment plant simulator GPS-X (Hydromantis, 1999). The GPS-X model (default ASM1 using the same set of model parameters) is simulated according to the same principles. The influent wastewater is characterised similar to the URWARE input (although not as many variables are described in GPS-X). We can see that the results are similar to the URWARE results.

Influent wastewater (from GPS-X, URWARE inputs within parenthesis)

BOD₇ = 64.3 g/m³ (64.3)
COD total = 151 g/m³ (150.8)
COD biodegradable_soluble = 17.3 g/m³ (17.3)
COD sol_inert = 30 g/m³ (30)
COD slowly biodeg part = 12.4 g/m³ (12.4)
COD part_inert = 21.9 g/m³ (21.9)
COD Heterotrophs = 69.2 g/m³ (69.2)
COD Autotrophs = 0.004 g/m³ (0.004)

Volatile suspended solids (VSS) = 69 g/m³ (not used in URWARE but a backward calculation indicates a value of about 68.9 g/m³)
 Suspended solids (TSS) = 88.5 g/m³ (88.0)
 Flow rate = 4500 m³/d (4500)
 VSS content = 0.0069 % (not used in URWARE but 0.0069%)
 TSS content = 0.0088 % (0.0088)

Total nitrogen = 57.0 g/m³ (66.2)
 N-NH₃ & N-NH₄ = 51.2 g/m³ (51.2)
 N-NO₃ = 0.99 g/m³ (0.99)
 N-org,part not Xnd = ??? g/m³ (7.1) not described in ASM1
 N-org,sol not Snd = ??? g/m³ (2.2) not described in ASM1
 N-org, Snd = 4.0 g/m³ (4.0)
 N-org, Xnd = 0.78 g/m³ (0.78)

Effluent wastewater (from GPS-X, URWARE results (Case 6.3) within parenthesis)

BOD₇ = 25.7 g/m³ (25.6)
 COD total = 105.0 g/m³ (104.6)
 COD biodegradable_soluble = 1.8 g/m³ (2.0)
 COD sol_inert = 30 g/m³ (30)
 COD slowly biodeg part = 0.3 g/m³ (0.3)
 COD part_inert = 35.3 g/m³ (35.2)
 COD Heterotrophs = 32.0 g/m³ (32.0)
 COD Autotrophs = 5.2 g/m³ (5.2)

Volatile suspended solids (VSS) = 48.5 g/m³ (not used in URWARE but a backward calculation indicates a value of about 44.9 g/m³)
 Suspended solids (TSS) = 59.8 g/m³ (60.0)
 Flow rate = 4500 m³/d (4500)
 VSS content = 0.0049 % (not used in URWARE but 0.0045%)
 TSS content = 0.0060 % (0.0060)

Total nitrogen = 57.4 g/m³ (64.5)
 N-NH₃ & N-NH₄ = 0.95 g/m³ (1.0)
 N-NO₃ = 55.6 g/m³ (55.3)
 N-org,part not Xnd = ??? g/m³ (5.1) not described in ASM1
 N-org,sol not Snd = ??? g/m³ (2.2) not described in ASM1
 N-org, Snd = 0.85 g/m³ (0.85)
 N-org, Xnd = 0.02 g/m³ (0.02)

N₂ production = 2523 kg N₂/y (2735)

The results from the two implementations are similar. The reason for the difference in total nitrogen is because some nitrogen fractions are not modelled by ASM1 (as used in GPS-X). Moreover, the total nitrogen for GPS-X appears strange. The total nitrogen effluent concentration is higher than the total nitrogen influent concentration. However, this is an effect on the uncomplete nitrogen balance in the default ASM1 model. The nitrogen content of the influent Heterotrophs are not included in the total influent nitrogen and as a results of the net positive biomass decay and hydrolysis (considerable higher concentration of Heterotrophs in the influent than in the effluent) a net amount of nitrogen is 'created' within the reactor. This organic nitrogen is consequently ammonified and then nitrified. The nitrogen balance of the URWARE model is more consistent and mass balances are always maintained. The small amount of produced nitrogen gas in the

two implementations differ slightly (i.e. processes related to simultaneous nitrification/denitrification). This process is, however, almost negligible in the modelled aerobic conditions.

6.4 Activated sludge settler

The model of the secondary clarifier of the activated sludge system is developed specifically for this purpose. It will not work properly as a stand-alone model but is instead always expected to be connected to the activated sludge biological reactors. It makes use of all the defined global variables created by `spASInput.m` (see subsection 6.1) and also requires information about the hydraulic retention time of the biological reactors. The purpose of the model is to maintain a requested sludge age for the biological system and produce reasonable output concentrations in the effluent and sludge flows. Moreover, at this stage the transformation of the URWARE AS vector of 91 elements back to the original 84 elements is carried out within this module (the transformation from 84 to 91 elements is performed within `spASInput.m` (see subsection 6.1)). Consequently, all wastewater flows that are to be connected to other modules of the WWTP must leave the AS system via the secondary clarifier effluent or sludge wastage flows. Naturally it would be easy to move these transformations into a separate module but so far this has not been done.

The behaviour of the activated sludge settler model is influenced by nine parameters defined by the user. These parameters are defined in the main initialisation file for the WWTP-model (`spInit.m`). The parameters are:

- **spASHydRetTime**: total hydraulic retention time for AS reactors in days (anox + aerob volume).
- **spASSludgeAge**: requested sludge age of the biological system in days (anoxic + aerobic).
- **spASRecycleFrac**: fraction of influent flow to the AS system recycled from settler ($Q_r = Q_{in} * \text{spASRecycleFrac}$).
- **spASWastageFrac**: fraction of influent flow to the AS system wasted from settler ($Q_w = Q_{in} * \text{spASWastageFrac}$).
- **spCODtoVS(1,1)**: conversion factor for calculating volatile solids (VS) from biodegradable COD. Suggested value $1/1.42 \approx 0.704$ (Metcalf & Eddy, 1991).
- **spCODtoVS(2,1)**: conversion factor for calculating volatile solids (VS) from inert COD. Suggested value $1/1.9 \approx 0.526$.
- **f_P_true**: calculated as $f_P / (1 - Y_H + Y_H * f_P)$. f_P_{true} is the actual inert fraction due to biomass decay whereas f_P is related to ASM1 death-regeneration concept.
- **spASIdealEnergy(1,1)**: defines the energy required for sludge scrapers. Suggested value 5400 J/m^3 of influent flow ($= 1.5 \text{ Wh/m}^3$).
- **spASIdealEnergy(2,1)**: defines the energy required for pumping. Suggested value 180000 J/m^3 of pumped flow ($= 50 \text{ Wh/m}^3$).

The parameters above are gathered into the input parameter vec-

tor (`spASIdealSPAR`) in `spInit.m` and included as an argument in `spASIdealSModel.m` when calling the actual activated sludge settler model. The complete source code for the model is available in Appendix Q.

In principle the model is based on the concept of ideal settlers. No biological reactions are assumed to occur in the settler. The model will produce an underflow sludge concentration so that a requested sludge age in the biological system can be achieved. In many cases ideal settler models do not represent the amount of sludge that leaves the system via the effluent and how much leaves via the sludge wastage flow. As this is of great importance for the URWARE system the traditional ideal settler model has been somewhat modified.

The steady state sludge age is based on sludge mass (i.e. TSS) and defined as:

mass of TSS in biological reactors/mass of TSS removed from the system per time unit

Based on this definition and a simple mass balance over the settler we can define the thickening factor for the settler sludge underflow concentration:

$$\text{thick_fact} = (Q_{\text{in}} + Q_{\text{r}} - V/\text{sludge_age})/Q_{\text{r}}$$

where Q_{in} = influent flow rate to the AS system (i.e. `spASVolumeFlowIn`), Q_{r} = recycled flow rate from settler, V = volume of the biological reactors and `sludge_age` is the sludge age we want the system to have. The thickening factor represents the ratio of TSS concentration in the settler underflow and the TSS concentration in the settler influent. All the above values are known and the thickening factor can be calculated. However, as the user explicitly defines the wastage flow rate in this model some further considerations must be made. The maximum possible wastage flow ($\max Q_{\text{w}}$) rate can be calculated as:

$$\max Q_{\text{w}} = (Q_{\text{in}} + Q_{\text{r}} * (1 - \text{thick_fact}))/\text{thick_fact}$$

otherwise the requested sludge age cannot be maintained due to a too high removal rate of sludge. The model checks this and corrects the user if the selected Q_{w} is higher than the requested Q_{w} . When Q_{w} is properly selected a simple mass balance is used to calculate the TSS concentration in the effluent flow as any sludge not removed via the sludge wastage flow must leave the system via the effluent flow. This way a reasonable TSS concentration is also achieved in the effluent (instead of assuming a value of zero, which is often used for ideal settlers). The model also provides the user with a warning if the effluent TSS concentration is above 100 mg/l as this would indicate that Q_{w} should probably be increased. If Q_{w} is set exactly to its maximum value then the TSS concentration in the effluent will be zero. Based on the above we can then define also a thinning factor, which represents the ratio of TSS concentration in the settler effluent and the TSS concentration in the settler influent.

In principle the concentrations of all variables can now be defined. The

soluble components are not affected by the settler, i.e. the output concentrations in the underflow and effluent are identical to the input concentrations. All particulate components in the underflow are equal to their input concentrations multiplied by the thickening factor and all particulate components in the effluent are equal to their input concentrations multiplied by the thinning factor. A small problem related to the fact that URWARE base the total volume on water + TS (as discussed previously) means that some further small adjustments are made as the TS in the effluent are very different from the TS in the underflow. However, the dissolved part of the TS should be the same in both flows and therefore some small modifications are made to the water fraction of the two flows to guarantee that the total flow (water + TS) are correct for both. In terms of mass balances it is essential that the total flows in and out of the module are identical. The interested reader is referred to the source code for this model to see how this is accomplished (it makes use of the global variables defined in subsection 6.1).

As the effluent and sludge wastage flows will be connected to other modules of the URWARE system, naturally the specially extended vector of 91 elements used within the AS system must be converted back to the original 84 elements. For most variables this is done in a straightforward manner. The variables that were added for the AS system are:

- slowly biodegradable substrate as COD, element 85
- heterotrophic biomass as COD, element 86
- autotrophic biomass as COD, element 87
- soluble organic N associated with element 75, element 88
- particulate organic N associated with element 85 = XND, element 89
- particulate organic P associated with element 85 = XPD, element 90
- particulate organic S associated with inerts, element 91

The sulphur element no 91 is added to element no 46 (particulate sulphur) and the phosphorus element no 90 is added to element no 80 (phosphorus content of particulate material). The nitrogen element no 88 is added to element no 44 (nitrogen content of soluble material) and element no 89 is added to element no 81 (nitrogen content of particulate material). Only for the three COD elements some special arrangements are made. Obviously these three should make up the two traditional URWARE elements 77 and 78 (particulate biodegradable COD and particulate inert COD). Element 85 is immediately moved into element 77. However, for active biomass (86 and 87) we also need to consider that when these components are used as organic substrate in other modules (via decay and hydrolysis) they contain material that cannot be completely degraded but will be biologically inert. Here we make use of the special model parameter **f_P_true**, which represents the actual inert fraction of biomass as a result of decay. It is calculated based on Heterotrophs but also used for the autotrophic biomass as the Heterotrophs will certainly make up a main part. This leads to the following conversion:

$\text{newelement}(77) = \text{element}(85) + (\text{element}(86) + \text{element}(87)) * (1 - \mathbf{f_P_true})$

$\text{newelement}(78) = \text{oldelement}(78) + (\text{element}(86) + \text{element}(87)) * \mathbf{f_P_true}$

There may certainly be other ways of achieving an appropriate conversion between the 91 elements vector and the 84 elements vector. The above method is the default in the model but any user can easily modify this if the need occurs. The above conversions mean that for the secondary clarifier model mass balances are not maintained on an individual component basis. However, with regard to total COD, total N, total P and total S all mass balances hold. Note that for VS and BOD the mass balances do not hold. This is an effect of that the ratio of biodegradable COD and inert COD have been slightly modified as we assume that part of the biomass will be inert material (basically we are saying that biomass decay appears as the components leave the AS system). With this in mind it is perfectly natural that the VS and BOD values are somewhat affected. The BOD calculations are carried out somewhat differently in this module than previously described. The output BOD of the different flows are based on the ratio of output biodegradable COD (in that specific flow) and the influent biodegradable COD. This factor is then multiplied by the influent total BOD. In the other modules a user defined conversion value is used (**spCODtoBOD**). The impact of this slightly different approach is very limited. As pointed out before, BOD is only an extra user variable and never used in any actual calculations within the URWARE WWTP models. COD is the basis for all transformations.

To avoid some numerical difficulties in terms of checking the validity of the results, simulation time is included as an extra input into the model.

The final model output is a vector of 84 elements characterising the effluent wastewater, a vector of 84 elements representing the sludge wastage flow and a vector of 91 elements representing the recycled flow (as this flow remains within the AS system it should not be converted into an 84 element vector).

Finally, three extra variables are given in the output vector for further analysis by the user:

- energy for sludge scrapers;
- energy for pumping.

The energy usage is divided into two sub-categories and based on several assumptions (see also Chapter 9). Energy use is normally calculated in relation to flow so that the energy use automatically adjusts to plants of different sizes and different layouts of the same plant. The energy requirements of the clarification unit is divided into two categories: energy for pumping and energy for sludge scrapers. The energy for sludge scrapers is defined by the parameter **spASIdealEnergy(1,1)** and the suggested value is 1.5 Wh per m³ of influent flow to the unit (5400 J/m³) and energy for pumping is defined by the parameter **spASIdealEnergy(2,1)** and the

suggested value is 50 Wh/m³ of the sludge flow (180000 J/m³). Only the sludge stream is assumed to require pumping whereas the effluent water is self-flowing as a result of a good hydraulic design of the whole plant. The two different energy categories are then added together and given as an output variable from the model.

In order to account for the different energy efficiencies for small and large plants a special function is used by which all energy values are multiplied in all models. The shape of this function is defined by the user and simply represents the fact that the energy requirements for a small plant is normally higher than that of a large plant per m³ of treated wastewater since large electrical drives are normally more efficient than small ones. The energy adjustment function is further discussed in Chapter 9. The values suggested for the two spASIdealSEnergy parameters represent the situation at a large and energy-efficient WWTP.

As mentioned above, the AS settler model should not be used as a stand-alone model. To demonstrate the general behaviour of the model, we instead connect the model to a predenitrifying system and makes a simulation of an entire AS system (see Figure 6.1). The influent wastewater is defined as the influent used in Case 6.1 (note the high ammonia concentration). All relevant parameter values are given below. Note that the energy adjustment function is not activated in the case shown below.

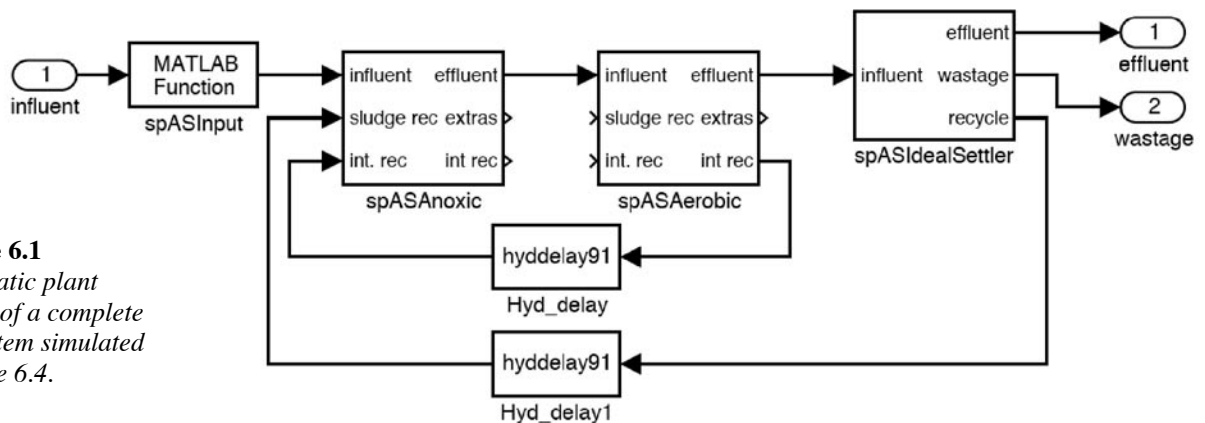

Figure 6.1
Schematic plant layout of a complete AS system simulated in Case 6.4.

Case 6.4: Simulation of a predenitrifying activated sludge system.

The system is simulated using an hydraulic retention time of 0.6 days (14.4 hours) in the biological reactors (i.e. 2700 m³). 45% of the reactor volume is anoxic and 55% is aerobic. The sludge age is set at 12 days. The internal recirculation flow is 300% of the influent flow and the sludge recycle flow is 100% of the influent flow. The oxygen concentration in the aerobic reactor is set to 2 mg/l and an external carbon source is used in the anoxic reactor (3 m³/d with a concentration of 300 g COD/l). The sludge wastage flow is 1.8% of the influent flow. All model parameters in spASAnoxDEF and spASAerobDEF are defined according to the values given in Sections 6.2 and 6.3.

Model parameters for the activated sludge system

The conversion of the wastewater variables when entering the activated sludge system is carried out as described in Section 6.1.

Model parameters for the anoxic reactor:

spASHydRetTime = 0.6 days
spASAnoxFrac = 45%
spASAnoxExtCFlow = 3 m³/d
spASAnoxIntRecFrac = 0%
spCODtoBOD = 0.65 mg BOD₇/mg COD_{biodegradable}
spCODtoVS(1,1) = 1/1.42 ≈ 0.704
spCODtoVS(2,1) = 1/1.9 ≈ 0.526
spCODtoSS(1,1) = 0.75 g SS/g COD
spCODtoSS(2,1) = 0.9 g SS/g COD
spASAnoxExtCConc = 300000 g/m³
spASSludgeAge = 12 days
spASAnoxEnergy(1,1): 2.5 W/m³
spASAnoxEnergy(2,1): 72000 J/m³
spASAnoxEnergy(3,1): 1800000 J/kg O₂

Model parameters for the aerobic reactor:

spASHydRetTime = 0.6 days
spASAerobFrac = 55%
spASAerobSOlevel = 2.0 mg/l
spASAerobIntRecFrac = 300%
spCODtoBOD = 0.65 mg BOD₇/mg COD_{biodegradable}
spCODtoVS(1,1) = 1/1.42 ≈ 0.704
spCODtoVS(2,1) = 1/1.9 ≈ 0.526
spCODtoSS(1,1) = 0.75 g SS/g COD
spCODtoSS(2,1) = 0.9 g SS/g COD
spASAerobAirEff = 0.67
spASSludgeAge = 12 days
spASAerobEnergy(1,1): 2.5 W/m³
spASAerobEnergy(2,1): 72000 J/m³
spASAerobEnergy(3,1): 1800000 J/kg O₂

Model parameters for the activated sludge secondary clarifier:

SpASHydRetTime = 0.6 days
spASSludgeAge = 12 days
spASRecycleFrac = 100%
spASWastageFrac = 1.8%
spCODtoVS(1,1) = 1/1.42 (g VS/g COD_{biodegradable})
spCODtoVS(2,1) = 1/1.9 (g VS/g COD_{inert})
f_{P,true} = $f_P / (1 - Y_H + Y_H * f_P)$ = 0.2086
spASIdealSEnergy(1,1): 5400 J/m³
spASIdealSEnergy(2,1): 180000 J/m³

Influent wastewater

BOD7 = 96.8394 g/m³; 159051.9885 kg/y; 21.7879 g/cap.day
 COD total = 195.4415 g/m³; 320999.2011 kg/y; 43.9725 g/cap.day
 COD biosol= 105.2091 g/m³; 172798.7786 kg/y; 23.6711 g/cap.day
 COD insol = 29.9957 g/m³; 49265.8225 kg/y; 6.7487 g/cap.day
 COD biopart = 40.0337 g/m³; 65752.6 kg/y; 9.0072 g/cap.day
 COD inpart = 20.203 g/m³; 33182 kg/y; 4.5455 g/cap.day
 Sum of COD-fractions = 320999.2011 kg/y

Volatile solids (VS) = 128.704 g/m³; 211387.5194 kg/y; 28.9572 g/cap.day
 Suspended solids (TSS) = 44.9623 g/m³; 73847.4571 kg/y; 10.1161 g/cap.day
 Dissolved solids (TS-TSS) = 769.7444 g/m³; 1264252.2215 kg/y; 173.1852 g/cap.day
 Fixed solids (TS-VS) = 686.0026 g/m³; 1126712.1592 kg/y; 154.3441 g/cap.day
 Total solids (TS) = 814.7067 g/m³; 1338099.6786 kg/y; 183.3013 g/cap.day
 H2O = 1641093140.9038 kg/y; 224.8073 kg/cap.day
 Total volume = 1642431.2406 m³/y; 4499.8116 m³/day
 VS content = 0.01287 %
 TSS content = 0.0044962 %
 TS content = 0.081471 %

Total nitrogen = 80.2949 g/m³; 131878.8692 kg/y; 18.0656 g/cap.day
 N-NH₃ & N-NH₄ = 51.9955 g/m³; 85399.1072 kg/y; 11.6985 g/cap.day
 N-NO₃ = 0.072316 g/m³; 118.7748 kg/y; 0.016271 g/cap.day
 N-N₂O = 0 g/m³; 0 kg/y; 0 g/cap.day
 N-org,part = 3.0118 g/m³; 4946.7 kg/y; 0.67763 g/cap.day
 N-org,sol = 25.2152 g/m³; 41414.2871 kg/y; 5.6732 g/cap.day
 Sum of N-fractions = 131878.8692 kg/y
 N content per TSS (N-org,part/TSS) = 6.6985 %
 N content per TS (Total N/TS) = 9.8557 %

Total sulphur = 4.1151 g/m³; 6758.7547 kg/y; 0.92586 g/cap.day
 SO₄-S = 2.654 g/m³; 4359.0365 kg/y; 0.59713 g/cap.day
 S particulate = 0.13407 g/m³; 220.2 kg/y; 0.030164 g/cap.day
 Sulfide HS-S = 1.327 g/m³; 2179.5182 kg/y; 0.29856 g/cap.day
 Sum of S-fractions = 6758.7547 kg/y
 S content per TSS (S particulate/TSS) = 0.29818 %
 S content per TS (Total S/TS) = 0.5051 %

Total phosphorus = 2.5227 g/m³; 4143.3699 kg/y; 0.56758 g/cap.day
 PO₄-P = 1.9997 g/m³; 3284.3699 kg/y; 0.44991 g/cap.day
 P particulate = 0.52301 g/m³; 859 kg/y; 0.11767 g/cap.day
 Sum of P-fractions = 4143.3699 kg/y
 P content per TSS (P particulate/TSS) = 1.1632 %
 P content per TS (Total P/TS) = 0.30965 %

Total potassium = 18.9068 g/m³; 31053.1308 kg/y; 4.2539 g/cap.day
 Dissolved potassium = 18.8068 g/m³; 30888.8808 kg/y; 4.2314 g/cap.day
 Organically bound potassium = 0.1 g/m³; 164.25 kg/y; 0.0225 g/cap.day
 K content per TSS (Organically bound K/TSS) = 0.22242 %
 K content per TS (Total K/TS) = 2.3207 %
 Temperature in water = 20 degC

Modified input wastewater vector (after spASInput, 91 elements vector)

BOD7 = 96.8394 g/m³; 159051.9885 kg/y; 21.7879 g/cap.day
 COD total = 195.4415 g/m³; 320999.2011 kg/y; 43.9725 g/cap.day
 COD biosol= 105.2091 g/m³; 172798.7786 kg/y; 23.6711 g/cap.day
 COD insol = 29.9957 g/m³; 49265.8225 kg/y; 6.7487 g/cap.day

The URWARE Wastewater Treatment Plant Models

COD biopart = 40.0337 g/m³; 65752.6 kg/y; 9.0072 g/cap.day
COD inpart = 20.203 g/m³; 33182 kg/y; 4.5455 g/cap.day
COD slowly biodeg part = 39.9937 g/m³; 65686.8474 kg/y; 8.9982 g/cap.day
COD Heterotrophs = 0.03603 g/m³; 59.1773 kg/y; 0.0081065 g/cap.day
COD Autotrophs = 0.0040034 g/m³; 6.5753 kg/y; 0.00090072 g/cap.day
Sum of COD-fractions = 320999.2011 kg/y

Volatile solids (VS) = 128.704 g/m³; 211387.5194 kg/y; 28.9572 g/cap.day
Suspended solids (TSS) = 44.9623 g/m³; 73847.4571 kg/y; 10.1161 g/cap.day
Dissolved solids (TS-TSS) = 769.7444 g/m³; 1264252.2215 kg/y; 173.1852 g/cap.day
Fixed solids (TS-VS) = 686.0026 g/m³; 1126712.1592 kg/y; 154.3441 g/cap.day
Total solids (TS) = 814.7067 g/m³; 1338099.6786 kg/y; 183.3013 g/cap.day
H₂O = 1641093140.9038 kg/y; 224.8073 kg/cap.day
Total volume = 1642431.2406 m³/y; 4499.8116 m³/day
VS content = 0.01287 %
TSS content = 0.0044962 %
TS content = 0.081471 %

Total nitrogen = 80.2949 g/m³; 131878.8692 kg/y; 18.0656 g/cap.day
N-NH₃ & N-NH₄ = 51.9955 g/m³; 85399.1072 kg/y; 11.6985 g/cap.day
N-NO₃ = 0.072316 g/m³; 118.7748 kg/y; 0.016271 g/cap.day
N-N₂O = 0 g/m³; 0 kg/y; 0 g/cap.day
N-org,part not Xnd = 1.0121 g/m³; 1662.3775 kg/y; 0.22772 g/cap.day
N-org,sol not Snd = 2.1884 g/m³; 3594.231 kg/y; 0.49236 g/cap.day
N-org, Snd = 23.0269 g/m³; 37820.0562 kg/y; 5.1808 g/cap.day
N-org Xnd = 1.9997 g/m³; 3284.3225 kg/y; 0.44991 g/cap.day
Sum of N-fractions = 131878.8692 kg/y

Total sulphur = 4.1151 g/m³; 6758.7547 kg/y; 0.92586 g/cap.day
SO₄-S = 2.654 g/m³; 4359.0365 kg/y; 0.59713 g/cap.day
S particulate,bio = 0.089014 g/m³; 146.2001 kg/y; 0.020027 g/cap.day
Sulfide HS-S = 1.327 g/m³; 2179.5182 kg/y; 0.29856 g/cap.day
S particulate,inert = 0.045055 g/m³; 73.9999 kg/y; 0.010137 g/cap.day
Sum of S-fractions = 6758.7547 kg/y

Total phosphorus = 2.5227 g/m³; 4143.3699 kg/y; 0.56758 g/cap.day
PO₄-P = 1.9997 g/m³; 3284.3699 kg/y; 0.44991 g/cap.day
P particulate not Xpn = 0.17576 g/m³; 288.6737 kg/y; 0.039544 g/cap.day
P part Xpn = 0.34725 g/m³; 570.3263 kg/y; 0.078127 g/cap.day
Sum of P-fractions = 4143.3699 kg/y

Total potassium = 18.9068 g/m³; 31053.1308 kg/y; 4.2539 g/cap.day
Dissolved potassium = 18.8068 g/m³; 30888.8808 kg/y; 4.2314 g/cap.day
Organically bound potassium = 0.1 g/m³; 164.25 kg/y; 0.0225 g/cap.day
Temperature in water = 20 degC

Steady state situation in the anoxic reactor

BOD₇ = 1052.3144 g/m³; 8641769.8547 kg/y; 1183.8041 g/cap.day
COD total = 2741.0039 g/m³; 22509552.2776 kg/y; 3083.5003 g/cap.day
COD biosol = 6.1183 g/m³; 50244.1143 kg/y; 6.8828 g/cap.day
COD insol = 29.9957 g/m³; 246329.1124 kg/y; 33.7437 g/cap.day
COD biopart = 1612.8269 g/m³; 13244786.4314 kg/y; 1814.3543 g/cap.day
COD inpart = 1092.0631 g/m³; 8968192.6196 kg/y; 1228.5195 g/cap.day
COD slowly biodeg part = 18.4798 g/m³; 151758.6568 kg/y; 20.7889 g/cap.day
COD Heterotrophs = 1479.0841 g/m³; 12146469.4161 kg/y; 1663.8999 g/cap.day
COD Autotrophs = 115.2631 g/m³; 946558.3585 kg/y; 129.6655 g/cap.day
Sum of COD-fractions = 22509552.2776 kg/y

The URWARE Wastewater Treatment Plant Models

Volatile solids (VS) = 1730.6595 g/m³; 14212445.8473 kg/y; 1946.9104 g/cap.day
Suspended solids (TSS) = 2267.8196 g/m³; 18623688.4544 kg/y; 2551.1902 g/cap.day
Dissolved solids (TS-TSS) = 722.7829 g/m³; 5935606.2076 kg/y; 813.0967 g/cap.day
Fixed solids (TS-VS) = 1259.943 g/m³; 10346848.8146 kg/y; 1417.3765 g/cap.day
Total solids (TS) = 2990.6025 g/m³; 24559294.6619 kg/y; 3364.2869 g/cap.day
H₂O = 8187596908.2499 kg/y; 1121.5886 kg/cap.day
Total volume = 8212156.2029 m³/y; 22499.0581 m³/day
VS content = 0.17307 %
TSS content = 0.22678 %
TS content = 0.29906 %

Total nitrogen = 221.6184 g/m³; 1819965.0986 kg/y; 249.3103 g/cap.day
N-NH₃ & N-NH₄ = 13.7484 g/m³; 112903.8033 kg/y; 15.4663 g/cap.day
N-NO₃ = 4.6417 g/m³; 38118.3123 kg/y; 5.2217 g/cap.day
N-N₂O = 0 g/m³; 0 kg/y; 0 g/cap.day
N-org,part not Xnd = 198.5677 g/m³; 1630668.9403 kg/y; 223.3793 g/cap.day
N-org,sol not Snd = 2.1884 g/m³; 17971.1549 kg/y; 2.4618 g/cap.day
N-org, Snd = 0.97996 g/m³; 8047.5673 kg/y; 1.1024 g/cap.day
N-org Xnd = 1.4923 g/m³; 12255.3205 kg/y; 1.6788 g/cap.day
Sum of N-fractions = 1819965.0986 kg/y

Total sulphur = 11.1956 g/m³; 91939.736 kg/y; 12.5945 g/cap.day
SO₄-S = 2.7275 g/m³; 22398.7785 kg/y; 3.0683 g/cap.day
S particulate,bio = 5.1265 g/m³; 42099.7593 kg/y; 5.7671 g/cap.day
Sulfide HS-S = 0.9959 g/m³; 8178.485 kg/y; 1.1203 g/cap.day
S particulate,inert = 2.3456 g/m³; 19262.7132 kg/y; 2.6387 g/cap.day
Sum of S-fractions = 91939.736 kg/y

Total phosphorus = 42.7064 g/m³; 350711.6981 kg/y; 48.0427 g/cap.day
PO₄-P = 0.097658 g/m³; 801.9798 kg/y; 0.10986 g/cap.day
P particulate not Xpn = 42.2673 g/m³; 347105.3884 kg/y; 47.5487 g/cap.day
P part Xpn = 0.34149 g/m³; 2804.3298 kg/y; 0.38415 g/cap.day
Sum of P-fractions = 350711.6981 kg/y

Total potassium = 50.8227 g/m³; 417364.2217 kg/y; 57.1732 g/cap.day
Dissolved potassium = 16.948 g/m³; 139179.2483 kg/y; 19.0657 g/cap.day
Organically bound potassium = 33.8748 g/m³; 278184.9734 kg/y; 38.1075 g/cap.day
Temperature in water = 20 degC

Steady state situation in the aerobic reactor

BOD₇ = 1036.9551 g/m³; 3406254.9454 kg/y; 466.6103 g/cap.day
COD total = 2722.2892 g/m³; 8942345.5207 kg/y; 1224.9788 g/cap.day
COD biosol = 2.0428 g/m³; 6710.4029 kg/y; 0.91923 g/cap.day
COD insol = 29.9957 g/m³; 98531.6449 kg/y; 13.4975 g/cap.day
COD biopart = 1593.2727 g/m³; 5233681.8207 kg/y; 716.9427 g/cap.day
COD inpart = 1096.9779 g/m³; 3603421.6521 kg/y; 493.6194 g/cap.day
COD slowly biodeg part = 12.8889 g/m³; 42338.1503 kg/y; 5.7997 g/cap.day
COD Heterotrophs = 1463.5382 g/m³; 4807521.6933 kg/y; 658.5646 g/cap.day
COD Autotrophs = 116.8457 g/m³; 383821.9771 kg/y; 52.5784 g/cap.day
Sum of COD-fractions = 8942345.5207 kg/y

Volatile solids (VS) = 1716.6057 g/m³; 5638813.531 kg/y; 772.4402 g/cap.day
Suspended solids (TSS) = 2254.7456 g/m³; 7406529.1552 kg/y; 1014.593 g/cap.day
Dissolved solids (TS-TSS) = 735.8569 g/m³; 2417188.7096 kg/y; 331.1217 g/cap.day
Fixed solids (TS-VS) = 1273.9968 g/m³; 4184904.3337 kg/y; 573.2746 g/cap.day
Total solids (TS) = 2990.6025 g/m³; 9823717.8648 kg/y; 1345.7148 g/cap.day
H₂O = 3275038763.3 kg/y; 448.6354 kg/cap.day
Total volume = 3284862.4812 m³/y; 8999.6232 m³/day

The URWARE Wastewater Treatment Plant Models

VS content = 0.17166 %
TSS content = 0.22547 %
TS content = 0.29906 %

Total nitrogen = 221.0419 g/m³; 726092.1532 kg/y; 99.4647 g/cap.day
N-NH₃ & N-NH₄ = 2.265 g/m³; 7440.222 kg/y; 1.0192 g/cap.day
N-NO₃ = 17.0858 g/m³; 56124.5453 kg/y; 7.6883 g/cap.day
N-N₂O = 0 g/m³; 0 kg/y; 0 g/cap.day
N-org,part not Xnd = 197.6617 g/m³; 649291.6454 kg/y; 88.9441 g/cap.day
N-org,sol not Snd = 2.1884 g/m³; 7188.462 kg/y; 0.98472 g/cap.day
N-org, Snd = 0.72721 g/m³; 2388.7787 kg/y; 0.32723 g/cap.day
N-org Xnd = 1.1137 g/m³; 3658.4998 kg/y; 0.50116 g/cap.day
Sum of N-fractions = 726092.1532 kg/y

Total sulphur = 11.1956 g/m³; 36775.8884 kg/y; 5.0378 g/cap.day
SO₄-S = 3.6392 g/m³; 11954.2131 kg/y; 1.6376 g/cap.day
S particulate,bio = 5.0972 g/m³; 16743.5781 kg/y; 2.2936 g/cap.day
Sulfide HS-S = 0.10324 g/m³; 339.1132 kg/y; 0.046454 g/cap.day
S particulate,inert = 2.356 g/m³; 7738.984 kg/y; 1.0601 g/cap.day
Sum of S-fractions = 36775.8884 kg/y

Total phosphorus = 42.7064 g/m³; 140284.713 kg/y; 19.2171 g/cap.day
PO₄-P = 0.40787 g/m³; 1339.8027 kg/y; 0.18353 g/cap.day
P particulate not Xpn = 42.0372 g/m³; 138086.2725 kg/y; 18.9159 g/cap.day
P part Xpn = 0.26139 g/m³; 858.6377 kg/y; 0.11762 g/cap.day
Sum of P-fractions = 140284.713 kg/y

Total potassium = 50.8228 g/m³; 166945.7567 kg/y; 22.8693 g/cap.day
Dissolved potassium = 17.2272 g/m³; 56589.0481 kg/y; 7.7519 g/cap.day
Organically bound potassium = 33.5955 g/m³; 110356.7086 kg/y; 15.1174 g/cap.day
Temperature in water = 20 degC

Effluent wastewater from the secondary clarifier (84 elements vector)

BOD₇ = 13.7909 g/m³; 22242.9594 kg/y; 3.047 g/cap.day
COD total = 72.858 g/m³; 117510.2664 kg/y; 16.0973 g/cap.day
COD biosol = 2.0428 g/m³; 3294.8078 kg/y; 0.45134 g/cap.day
COD insol = 29.9957 g/m³; 48379.0377 kg/y; 6.6273 g/cap.day
COD biopart = 19.174 g/m³; 30925.1297 kg/y; 4.2363 g/cap.day
COD inpart = 21.6455 g/m³; 34911.2912 kg/y; 4.7824 g/cap.day
Sum of COD-fractions = 117510.2664 kg/y

Volatile solids (VS) = 42.121 g/m³; 67935.5627 kg/y; 9.3062 g/cap.day
Suspended solids (TSS) = 34.2115 g/m³; 55178.6422 kg/y; 7.5587 g/cap.day
Dissolved solids (TS-TSS) = 769.7444 g/m³; 1241495.6815 kg/y; 170.0679 g/cap.day
Fixed solids (TS-VS) = 761.8349 g/m³; 1228738.761 kg/y; 168.3204 g/cap.day
Total solids (TS) = 803.9559 g/m³; 1296674.3237 kg/y; 177.6266 g/cap.day
H₂O = 1611570803.9282 kg/y; 220.7631 kg/cap.day
Total volume = 1612867.4783 m³/y; 4418.815 m³/day
VS content = 0.0042121 %
TSS content = 0.0034212 %
TS content = 0.080396 %

Total nitrogen = 25.2824 g/m³; 40777.2045 kg/y; 5.5859 g/cap.day
N-NH₃ & N-NH₄ = 2.265 g/m³; 3653.149 kg/y; 0.50043 g/cap.day
N-NO₃ = 17.0858 g/m³; 27557.1518 kg/y; 3.775 g/cap.day
N-N₂O = 0 g/m³; 0 kg/y; 0 g/cap.day
N-org,part = 3.016 g/m³; 4864.4786 kg/y; 0.66637 g/cap.day
N-org,sol = 2.9156 g/m³; 4702.4252 kg/y; 0.64417 g/cap.day

The URWARE Wastewater Treatment Plant Models

Sum of N-fractions = 40777.2045 kg/y
N content per TSS (N-org,part/TSS) = 8.8159 %
N content per TS (Total N/TS) = 3.1448 %

Total sulphur = 3.8555 g/m³; 6218.4183 kg/y; 0.85184 g/cap.day
SO₄-S = 3.6392 g/m³; 5869.5186 kg/y; 0.80404 g/cap.day
S particulate = 0.11309 g/m³; 182.3951 kg/y; 0.024986 g/cap.day
Sulfide HS-S = 0.10324 g/m³; 166.5046 kg/y; 0.022809 g/cap.day
Sum of S-fractions = 6218.4183 kg/y
S content per TSS (S particulate/TSS) = 0.33055 %
S content per TS (Total S/TS) = 0.47957 %

Total phosphorus = 1.0497 g/m³; 1692.9827 kg/y; 0.23192 g/cap.day
PO₄-P = 0.40787 g/m³; 657.8431 kg/y; 0.090115 g/cap.day
P particulate = 0.6418 g/m³; 1035.1396 kg/y; 0.1418 g/cap.day
Sum of P-fractions = 1692.9827 kg/y
P content per TSS (P particulate/TSS) = 1.876 %
P content per TS (Total P/TS) = 0.13056 %

Total potassium = 17.737 g/m³; 28607.3801 kg/y; 3.9188 g/cap.day
Dissolved potassium = 17.2272 g/m³; 27785.2226 kg/y; 3.8062 g/cap.day
Organically bound potassium = 0.50975 g/m³; 822.1575 kg/y; 0.11262 g/cap.day
K content per TSS (Organically bound K/TSS) = 1.49 %
K content per TS (Total K/TS) = 2.2062 %
Temperature in water = 20 degC

Sludge wastage flow from the secondary clarifier (84 elements vector)

BOD₇ = 1603.0457 g/m³; 47392.0635 kg/y; 6.4921 g/cap.day
COD total = 5278.0273 g/m³; 156038.3444 kg/y; 21.3751 g/cap.day
COD biosol = 2.0428 g/m³; 60.3936 kg/y; 0.0082731 g/cap.day
COD insol = 29.9957 g/m³; 886.7848 kg/y; 0.12148 g/cap.day
COD biopart = 2464.1814 g/m³; 72850.4733 kg/y; 9.9795 g/cap.day
COD inpart = 2781.8074 g/m³; 82240.6926 kg/y; 11.2658 g/cap.day
Sum of COD-fractions = 156038.3444 kg/y

Volatile solids (VS) = 3216.674 g/m³; 95096.9849 kg/y; 13.027 g/cap.day
Suspended solids (TSS) = 4396.7539 g/m³; 129984.5867 kg/y; 17.8061 g/cap.day
Dissolved solids (TS-TSS) = 769.7444 g/m³; 22756.54 kg/y; 3.1173 g/cap.day
Fixed solids (TS-VS) = 1949.8243 g/m³; 57644.1418 kg/y; 7.8965 g/cap.day
Total solids (TS) = 5166.4983 g/m³; 152741.1267 kg/y; 20.9234 g/cap.day
H₂O = 29411021.2038 kg/y; 4.0289 kg/cap.day
Total volume = 29563.7623 m³/y; 80.9966 m³/day
VS content = 0.32167 %
TSS content = 0.43968 %
TS content = 0.51665 %

Total nitrogen = 409.8786 g/m³; 12117.5531 kg/y; 1.6599 g/cap.day
N-NH₃ & N-NH₄ = 2.265 g/m³; 66.962 kg/y; 0.0091729 g/cap.day
N-NO₃ = 17.0858 g/m³; 505.1209 kg/y; 0.069195 g/cap.day
N-N₂O = 0 g/m³; 0 kg/y; 0 g/cap.day
N-org,part = 387.6122 g/m³; 11459.275 kg/y; 1.5698 g/cap.day
N-org,sol = 2.9156 g/m³; 86.1952 kg/y; 0.011808 g/cap.day
Sum of N-fractions = 12117.5531 kg/y
N content per TSS (N-org,part/TSS) = 8.8159 %
N content per TS (Total N/TS) = 7.9334 %

Total sulphur = 18.2761 g/m³; 540.3089 kg/y; 0.074015 g/cap.day
SO₄-S = 3.6392 g/m³; 107.5879 kg/y; 0.014738 g/cap.day

The URWARE Wastewater Treatment Plant Models

S particulate = 14.5336 g/m³; 429.669 kg/y; 0.058859 g/cap.day
Sulfide HS-S = 0.10324 g/m³; 3.052 kg/y; 0.00041808 g/cap.day
Sum of S-fractions = 540.3089 kg/y
S content per TSS (S particulate/TSS) = 0.33055 %
S content per TS (Total S/TS) = 0.35374 %

Total phosphorus = 82.89 g/m³; 2450.5414 kg/y; 0.33569 g/cap.day
PO₄-P = 0.40787 g/m³; 12.0582 kg/y; 0.0016518 g/cap.day
P particulate = 82.4822 g/m³; 2438.4832 kg/y; 0.33404 g/cap.day
Sum of P-fractions = 2450.5414 kg/y
P content per TSS (P particulate/TSS) = 1.876 %
P content per TS (Total P/TS) = 1.6044 %

Total potassium = 82.7385 g/m³; 2446.0617 kg/y; 0.33508 g/cap.day
Dissolved potassium = 17.2272 g/m³; 509.3014 kg/y; 0.069767 g/cap.day
Organically bound potassium = 65.5113 g/m³; 1936.7602 kg/y; 0.26531 g/cap.day
K content per TSS (Organically bound K/TSS) = 1.49 %
K content per TS (Total K/TS) = 1.6014 %
Temperature in water = 20 degC

Extra outputs from anoxic reactor

Added carbon source = 328500 kg COD/y; 16.425 kg COD/cap.y; 900 kg COD/day; 0.045 kg COD/cap.day
Total oxygen into system = 0 kg O₂/y; 0 kg O₂/cap.y; 0 kg O₂/day; 0 kg O₂/cap.day
CO₂ production = 315439.6886 kg CO₂/y; 15.772 kg CO₂/cap.y; 864.2183 kg CO₂/day; 0.043211 kg CO₂/cap.day
N₂ production = 74212.4284 kg N₂/y; 3.7106 kg N₂/cap.y; 203.3217 kg N₂/day; 0.010166 kg N₂/cap.day
N₂O production = 58.3389 kg N₂O/y; 0.0029169 kg N₂O/cap.y; 0.15983 kg N₂O/day; 7.9916e-06 kg N₂O/cap.day
Energy consumption (total) = 95.786 GJ/y; 26607.39 kWh/y
Energy consumption (mixing) = 95.786 GJ/y; 26607.39 kWh/y
Energy consumption (pumping) = 0 GJ/y; 0 kWh/y
Energy consumption (aeration) = 0 GJ/y; 0 kWh/y

Extra outputs from aerobic reactor

Biological oxygen consumption = 645513.3121 kg COD/y; 32.2757 kg COD/cap.y; 1768.5296 kg COD/day; 0.088426 kg COD/cap.day
Total oxygen into system = 987966.6037 kg O₂/y; 49.3983 kg O₂/cap.y; 2706.7578 kg O₂/day; 0.13534 kg O₂/cap.day
CO₂ production = 242687.846 kg CO₂/y; 12.1344 kg CO₂/cap.y; 664.8982 kg CO₂/day; 0.033245 kg CO₂/cap.day
N₂ production = 4702.8269 kg N₂/y; 0.23514 kg N₂/cap.y; 12.8845 kg N₂/day; 0.00064422 kg N₂/cap.day
N₂O production = 50.4089 kg N₂O/y; 0.0025204 kg N₂O/cap.y; 0.13811 kg N₂O/day; 6.9053e-06 kg N₂O/cap.day
Energy consumption (total) = 2133.105 GJ/y; 592529.1763 kWh/y
Energy consumption (mixing) = 0 GJ/y; 0 kWh/y
Energy consumption (pumping) = 354.765 GJ/y; 98545.8744 kWh/y
Energy consumption (aeration) = 1778.339 GJ/y; 493983.3019 kWh/y

Extra outputs from secondary clarifier

Amount of total energy used = 318.6974 GJ/y = 88527.0439 kWh/y; 12.127 Wh/cap.day
Amount of energy used for sludge scrapers = 17.7383 GJ/y = 4927.2937 kWh/y; 0.67497 Wh/cap.day
Amount of energy used for pumping = 300.9591 GJ/y = 83599.7501 kWh/y; 11.452 Wh/cap.day

There is not possibility to analyse the above results within this document. However, the experienced reader can use them as an example of the types of results provided by the URWARE AS module and investigate in more detail whether or not the results appear to be reasonable. The effluent COD may appear somewhat high from what is experienced in most plants. However, this could easily be adjusted by increasing the wastage flow from 1.8 to 2%. The high effluent nitrogen concentration is a result of the high influent ammonia load. It should be noted that the simulation set-up has been made without any real data from any actual plant. The operational parameters of the plant has simply been initiated to somewhat 'reasonable' values by the author in order to provide an example.

7

Anaerobic digestion

Anaerobic digestion is a complex biological process including a large number of transformations, kinetics, etc. In 2002 a state-of-the-art AD model (ADM1) was presented by an IWA Task Group, which sets the standard for dynamic modelling of AD processes (Batstone *et al.*, 2002). However, for the purpose of URWARE such a model is much too complex and significant simplifications must be imposed. This means that the model is only valid in steady state and it will only provide reasonable results when the digester is operating properly. Process collapse and other types of process failures cannot be detected. Moreover, the most sophisticated models for AD available only describe COD and nitrogen fractions, i.e. the fate regarding phosphorus, potassium and sulphur that are required by URWARE is highly speculative.

The anaerobic digestion model describes the digestion process for a CSTR digester working at mesophilic conditions (digester temperature defined by the user, usually 35-37 °C). The code describing the digester is given in Appendix R. The principle of the anaerobic digestion model is shown in Figure 7.1.

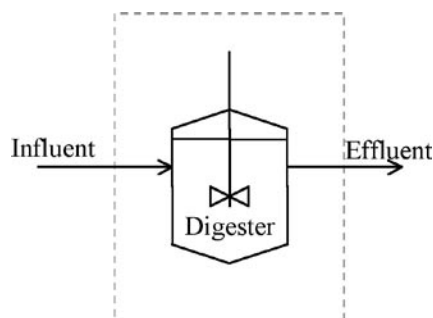

Figure 7.1.
General flow scheme for
the anaerobic digestion
model.

The behaviour of the digestion model is influenced by 26 parameters defined by the user. These parameters are defined in the main initialisation file for the WWTP-model (`spInit.m`). The parameters are:

- **adtemp**: temperature in digester (°C). Explicit parameter for anaerobic digestion sub-model (default value 35 °C).
- **cp**: heat capacity of water. Used for all temperatures (J/kg/C). Default value 4200 J/kg/C).

- **spCODtoBOD**: conversion factor for calculating BOD_7 from $COD_{\text{biodegradable}}$. Suggested value 0.65 mg BOD_7 /mg $COD_{\text{biodegradable}}$.
- **fAD_SI**: fraction of input biodegradable particulate COD ending up as soluble inert COD. Suggested value 0.05.
- **fAD_XI**: fraction of input biodegradable particulate COD ending up as particulate inert COD. Suggested value 0.15.
- **fAD_XB**: fraction of input biodegradable particulate COD ending up as biomass COD. Suggested value 0.20 (should not be interpreted as the actual observed yield, which is usually around 7% in anaerobic digesters).
- **fAD_prot**: fraction of digested COD from protein origin. Suggested value 0.30. Only used in model mode 1.
- **fAD_carbo**: fraction of digested COD from carbohydrate origin. Suggested value 0.35. Only used in model mode 1.
- **fAD_lipid**: fraction of digested COD from lipid origin. Suggested value 0.35. Only used in model mode 1.
- **CODtoCO2**: kg CO_2 produced per kg COD digested. Suggested value 0.5. Only used in model mode 0.
- **CODtoCH4**: kg CH_4 produced per kg COD digested. Suggested value 0.25. Only used in model mode 0. Weight ratio of CO_2 to CH_4 is 2.75 but for lipids more mol CH_4 is produced than CO_2 and therefore the ratio **CODtoCO2** and **CODtoCH4** is set to 2.
- **modelmode_AD**: sets model mode used in simulation (0 or 1).
- **Nratio_AD**: ratio of organic nitrogen in biodegradable:inert particulate AD sludge. Suggested value 2.
- **Pratio_AD**: ratio of organic phosphorus in biodegradable:inert particulate AD sludge. Suggested value 2.
- **Sratio_AD**: ratio of organic sulphur in biodegradable:inert particulate AD sludge. Suggested value 2.
- **Pprec_AD**: fraction of released PO_4 forming metal complex in the AD sludge. Suggested value 0.6.
- **Sprec_AD**: fraction of released HS^- forming metal complex in the AD sludge. Suggested value 0.8.
- **Sgas_AD**: fraction of non-precipitated HS^- released as in gas phase. Suggested value 0.1.
- **i_XBK**: mass K/mass COD in biodegradable particulate COD. Suggested value 0.02.
- **i_XEK**: mass K/mass COD in inert particulate COD. Suggested value 0.00.
- **CO2inwater_AD**: fraction of produced CO_2 dissolved in water phase. Suggested value 0.33.
- **heatrecov_AD**: fraction of total energy for heating recovered by heat exchangers (or possibly heat pumps). Suggested value 0.35.
- **spADEnergy(1,1)**: energy required for mixing. Suggested value 3600000 J/m³ of influent sludge (1 kWh/m³).
- **spADEnergy(2,1)**: energy required for pumping. Suggested value 180000 J/m³ of pumped flow (50 Wh/m³).
- **spADheatexchanger**: defines if heat exchangers are active or not (false or true). Suggested value true.

- **spADelheatexchanger**: defines the amount of electricity (J) required by heat exchangers to recover 1 J of heat. Suggested value 0.2.

The parameters above are gathered into the input parameter vector (spAD-PAR) in `spInit.m` and included as an argument in `spADModel.m` when calling the actual digestion model. Note that **spCODtoSS** and **spCODtoVS** are currently not used. The effluent TSS is based on the ratio of particulate COD in the influent and effluent. For VS it is simply assumed that 50% of the influent VS is reduced in the digester (standard value for normally operating digester). This is simply done to reduce complexity and to avoid having to define too many model variables.

As stated above modelling of biological processes is a complex task and therefore a second set of model parameters (14) are required by the AD model. These parameters are also defined in the main initialisation file for the WWTP-model (`spInit.m`) and should normally not be modified by the user unless substantial modelling knowledge exists. The parameters are:

- **spADDEF(1) = 2.5**: mol CO₂ produced per mol protein digested.
- **spADDEF(2) = 2.5**: mol CH₄ produced per mol protein digested.
- **spADDEF(3) = 113**: molar weight of protein (g/mol).
- **spADDEF(4) = 1.416**: COD content of protein (g COD/g).
- **spADDEF(5) = 3**: mol CO₂ produced per mol carbohydrates digested.
- **spADDEF(6) = 3**: mol CH₄ produced per mol carbohydrates digested.
- **spADDEF(7) = 162**: molar weight of carbohydrates (g/mol).
- **spADDEF(8) = 1.185**: COD content of carbohydrates (g COD/g).
- **spADDEF(9) = 17**: mol CO₂ produced per mol lipids digested.
- **spADDEF(10) = 40**: mol CH₄ produced per mol lipids digested.
- **spADDEF(11) = 884**: molar weight of lipids (g/mol).
- **spADDEF(12) = 2.90**: COD content of lipids (g COD/g).
- **spADDEF(13) = 44**: molar weight of CO₂ (g/mol).
- **spADDEF(14) = 16**: molar weight of CH₄ (g/mol).

The parameters above are gathered in the parameter vector (spADDEF) in `spInit.m` and included as an argument in `spADModel.m` when calling the actual digester model.

The differences related to mode 0 or 1 of the AD model primarily affect the gas production. If the user has adequate information regarding the composition of the influent sludge in terms of proteins, carbohydrates and lipids then this information can be included in mode 1 to get a better estimate of the produced gas. In mode 0 the parameters **CODtoCO2** and **CODtoCH4** will instead determine how much of the degraded COD will end up in the different gas fractions. However, in both cases the most important parameter to control the behaviour of the AD is the net amount of biodegradable particulate COD in the process that will be degraded. This amount is calculated as:

$$f_{AD_gas} = 1 - (f_{AD_SI} + f_{AD_XI} + f_{AD_XB})$$

and with the default values means that 60% of the influent biodegradable particulate COD will produce gas whereas the remaining part exists the system as inert soluble COD, inert particulate COD and biomass. The

inert COD fractions of the influent will not be affected by the AD and the soluble biodegradable COD is assumed to be completely degraded (as if it was 100% carbohydrates).

For nitrogen all influent nitrate is assumed to be immediately denitrified. For simplicity the associated COD reduction is neglected. We neglect any soluble organic nitrogen formed in the process (instead it is added to the ammonia pool) and for the particulate organic nitrogen we assume that the ratio N:particulate COD is the same in the output as in the input. However, we can control the content of particulate nitrogen associated with the biodegradable and inert particulate COD by using the parameter **Nratio_AD**. From a calculation point of view this means (using mass units rather than concentration units):

$$\mathbf{Nfrac} = \text{in}(81) / (\mathbf{Nratio_AD} * \text{in}(77) + \text{in}(78))$$

$$\text{out}(81) = \mathbf{Nratio_AD} * \mathbf{Nfrac} * \text{out}(77) + \mathbf{Nfrac} * \text{out}(78)$$

All remaining nitrogen is then assumed to leave the AD process in the form of ammonia.

In a similar way we assume that the ratio P:particulate COD is the same in the output as in the input. However, we can control the content of particulate phosphorus associated with the biodegradable and inert particulate COD by using the parameter **Pratio_AD**. However, the situation is slightly more complicated as we also include a parameter **Pprec_AD**, which allow us to define a fraction of phosphate that forms stable inorganic complex (by binding to metal ions or similar in the water). **Pfrac** used in Table 7.1 is defined by the same principle as **Nfrac**.

For sulphur the description is somewhat more complicated since we assume that HS^- can form stable particulate complex (similar to phosphate) by setting the parameter **Sprec_AD**, but also controls the amount of non-complex forming HS^- which is released into the gas phase as H_2S whereas the other part of HS^- is dissolved in the water phase. This is done via the parameter **Sgas_AD**. **Sfrac** used in Table 7.1 is defined by the same principle as **Nfrac**. All SO_4 in the influent water is assumed to be transformed into HS^- .

The amount of potassium within the cell structures of biodegradable and inert particulate COD is directly controlled via the parameters **i_XBK** and **i_XEK**. The remaining potassium is dissolved in the water. A number of checks and adjustments are done within the model to ensure that no extra potassium is added to the process (i.e. that the mass balances are fulfilled).

The output variable BOD is calculated based on the output COD fractions and the conversion parameter given in spADPAR, whereas TS and TSS is calculated based on the ratio to total and particulate COD, respectively, in the influent (similarly as was done in the sedimentation models). The output VS is simply assumed to be 50% of the input VS (based on mass). This represents a number within the range commonly found in many normally operating digesters (Svärd, 2003; Svärd *et al.*, 2004).

As a significant amount of gas is produced in the AD the output volume

(water + TS) is slightly lower than the input volume.

The details of how the different variables are calculated within the model for the water phase are presented in Table 7.1. Note that all in and out variables are assumed to be in mass units (by using `conc2load` on the influent vector and converting the output vector back to concentration units with `load2conc` before they are transferred to other modules).

Position. variable name	Relationship	Comment
6. BOD	$= \text{spCODtoBOD} * (\text{out}(75) + \text{out}(77))$	Calculated once effluent variables 75 and 77 are known
7. Volatile solids (VS)	$= \text{in}(7) * 0.50$	Simply assume 50% VS is reduced
8. Total solids (TS)	$= (\text{out}(75) + \text{out}(76) + \text{out}(77) + \text{out}(78)) * \text{in}(8) / (\text{in}(75) + \text{in}(76) + \text{in}(77) + \text{in}(78))$	Calculated once effluent variables 75, 76, 77 and 78 are known
10. Carbon dioxide (biological)	$= (\text{in}(75) + \text{fAD_gas} * \text{in}(77)) * \text{CODtoCO2} * \text{CO2inwater_AD}$	Model mode 0
22. Water	$\text{H2O_out} = \text{H2O_in}$	mass unit
23. Total nitrogen (N-tot)	$= \text{out}(24) + \text{out}(26) + \text{out}(44) + \text{out}(81)$	Calculated once effluent variables 24, 26, 46 and 81 are known
24. Ammonia/ammonium	$= \text{in}(23) - \text{in}(26) - \text{out}(44) - \text{out}(81)$	$\text{NH4_out} = \text{N_tot_in} - \text{NO3_in} - \text{N_part,org_out} - \text{Norg,sol_out}$
26. Nitrate/nitrite	$= 0$	All denitrified
28. Total sulphur (S-tot)	$= \text{out}(29) + \text{out}(46) + \text{out}(48)$	Calculated once effluent variables 29, 46 and 48 are known
29. Sulphate	$= 0$	Reduced into HS
30. Total phosphorus (P-tot)	$= \text{out}(79) + \text{out}(80)$	Calculated once effluent variables 79 and 80 are known
32. Total potassium (K-tot)	$= \text{in}(32)$	$\text{K_out} = \text{K_in}$
42. Suspended solids (TSS)	$= (\text{out}(77) + \text{out}(78)) * \text{in}(42) / (\text{in}(77) + \text{in}(78))$	Calculated once effluent variables 77 and 78 are known
43. Total COD	$= \text{out}(75) + \text{out}(76) + \text{out}(77) + \text{out}(78)$	Calculated once effluent variables 75, 76, 77 and 78 are known
44. Soluble organic nitrogen	$= \text{in}(44)$	$\text{Norg,sol_out} = \text{Norg,sol_in}$
46. Particulate sulphur	$\text{tempout}(46) = \text{Sratio_AD} * \text{Sfrac} * \text{out}(77) + \text{Sfrac} * \text{out}(78)$ $\text{out}(46) = \text{in}(28) - \text{tempout}(48)$	See text and code Calculate <code>tempout(46)</code> then calculate <code>tempout(48)</code> and then <code>out(46)</code> finally <code>out(48)</code>
48. Sulfide (HS-S)	$\text{tempout}(48) = (1 - \text{Sprec_AD}) * (\text{in}(28) - \text{tempout}(46))$ $\text{out}(48) = (1 - \text{Sprec_AD}) * \text{tempout}(48)$	See text and code
49. Organically bound potassium	$= \text{out}(77) * \text{i_XBK} + \text{out}(78) * \text{i_XEK}$	Number of checks in code to see if this is possible
75. COD, soluble&biodreg	$= 0$	All is degraded
76. COD, soluble&inert	$= \text{in}(76) + \text{fAD_SI} * \text{in}(77)$	$\text{CODsol,inert_out} = \text{CODsol,inert_in} + \text{CODsol,inert_formed}$
77. COD, part&biodreg	$= \text{fAD_XB} * \text{in}(77)$	$\text{CODpart,bio_out} = \text{CODpart,bio_formed}$ (biomass)
78. COD, part&inert	$= \text{in}(78) + \text{fAD_XI} * \text{in}(77)$	$\text{CODpart,inert_out} = \text{CODpart,inert_in} + \text{CODpart,inert_formed}$
79. Phosphate	$= (1 - \text{Pprec_AD}) * (\text{in}(30) - \text{tempout}(80))$	$\text{PO4_out} = \text{PO4_in} + \text{P_part to PO4}$
80. Phosphorus, particulate	$\text{tempout}(80) = \text{Pratio_AD} * \text{Pfrac} * \text{out}(77) + \text{Pfrac} * \text{out}(78)$ $\text{out}(80) = \text{in}(30) - \text{out}(79)$	See text and code Calculate <code>tempout(80)</code> then calculate <code>out(79)</code> and finally the actual <code>out(80)</code>
81. Nitrogen, org&particulate	$= \text{Nratio_AD} * \text{Nfrac} * \text{out}(77) + \text{Nfrac} * \text{out}(78)$	See text and code
82. Temperature	$= \text{adtemp}$	

Table 7.1
Calculating the variables in the effluent stream

Gas production

The AD model calculates the mass of produced methane, carbon dioxide, N₂ and H₂S. Calculation of produced hydrogen gas is not included. As stated before the **fAD_gas** parameter determines how much COD degradation that leads to gas production. In both model modes the production of H₂S is calculated as:

$$\text{H}_2\text{S}_{\text{gas}} = \text{S}_{\text{gas_AD}} * \text{tempout}(48)$$

and the produced N₂ is equal to NO₃-N in the input.

In mode 0 the parameters **CODtoCO2** and **CODtoCH4** defines the gas production of the degraded COD. For methane:

$$\text{CH}_4_{\text{produced}} = (\text{in}(75) + \text{fAD_gas} * \text{u}(77)) * \text{CODtoCH4}$$

whereas the CO₂ production is also affected by the parameter **CO2inwater_AD**, which defines how much CO₂ is released as gas and how much is dissolved in the water phase according to:

$$\text{CO}_2_{\text{total}} = (\text{in}(75) + \text{fAD_gas} * \text{u}(77)) * \text{CODtoCO2}$$

$$\text{CO}_2_{\text{gasphase}} = \text{CO}_2_{\text{total}} * (1 - \text{CO2inwater_AD})$$

$$\text{CO}_2_{\text{waterphase}} = \text{CO}_2_{\text{total}} * \text{CO2inwater_AD}$$

All produced CH₄ is assumed to move into the gas phase although this is a simplification as part of the produced methane will in reality also be dissolved in the water phase.

In mode 1 the calculations are instead based on ideal degradation of proteins, carbohydrates and lipids in an anaerobic environment (the fractions in the influent defined by the user). An assumption is made regarding the chemical composition of these fractions and then the reactions can be determined as (Christensen *et al.*, 2003):

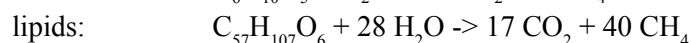
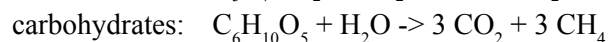
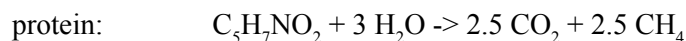

By determining the molar weights and the COD contents of the different substances (given in spADDEF) we can determine the mass of CH₄ and CO₂ that are formed from every mass of COD of proteins, carbohydrates and lipids. The principle is shown below for protein.

$$\text{protein2CH4} = \text{spADDEF}(2) * \text{spADDEF}(14) / (\text{spADDEF}(4) * \text{spADDEF}(3))$$

$$\text{protein2CO2} = \text{spADDEF}(1) * \text{spADDEF}(13) / (\text{spADDEF}(4) * \text{spADDEF}(3))$$

$$\text{CO2}_{\text{produced_from_protein}} = (\text{fAD_gas} * \text{fAD_prot} * \text{in}(77)) * \text{protein2CO2}$$

$$\text{CH4}_{\text{produced_from_protein}} = (\text{fAD_gas} * \text{fAD_prot} * \text{in}(77)) * \text{protein2CH4}$$

This is done in the same fashion for carbohydrates and lipids. The produced CO₂ is then also here divided into gas phase and water phase

according to **CO2inwater_AD**.

When using the default parameter values, the AD model produces approximately the same amounts of gas in both modes.

A number of extra output variables are provided for the user in relation to gas production:

- extras(11) = CO₂ production (kg/year) released as gas (another part in water)
- extras(12) = CH₄ production (kg/year) released as gas (all)
- extras(13) = H₂S production (kg/year) released as gas (another part in water as HS⁻)
- extras(14) = N₂ production (kg/year) released as gas (result of denitrification)

Energy requirements

Energy calculations for digesters are normally very site specific. Heat exchangers or heat pumps or gas engines connected to the system will drastically influence the general behaviour and energy requirements. For this reason only a rough suggestion is implemented in this software and in practically all cases the user will have to modify the code to fit his/her specific needs.

The energy usage is divided into several sub-categories. Energy use is normally calculated in relation to flow so that the energy use automatically adjusts to plants of different sizes and different layouts of the same plant. The electrical energy required for mixing of the digester is set to 1 kWh per m³ of influent flow to the unit (3.6 MJ/m³) via the parameter **spADEnergy(1,1)**. Energy for pumping the digested sludge out of the digester is set to 50 Wh/m³ (180000 J/m³) via the parameter **spADEnergy(2,1)**.

Heat is added to the system in order to obtain the chosen process temperature. The total amount of heat needed if no heat recovery is active would ideally (no losses, perfect isolation, etc.) be:

$$(\text{in}(22) + \text{in}(8)) * \text{cp} * (\text{adtemp} - \text{in}(82))$$

where **cp** = 4200 J/(kg*K)

i.e. the total mass into the digester times the required temperature increase times the heat capacity of water. In the default implementation it is assumed that heat exchangers are available and used (**spADheatexchanger**). The heat exchangers are characterised by two parameters – heat recovery efficiency (**heatrecov_AD**) and amount of electricity needed (J) for each amount of heat recovered (J) (**spADelheatexchanger**). Consequently, four categories of energy inputs are defined:

- Energy for mixing (electricity), extras(1);
- Energy for pumping (electricity), extras(2);
- Energy for heat exchangers (electricity), extras(3);
- Energy for heating (heat) if no heat exchangers were active, extras(4).

The digesters also produce energy in the form of:

- Heat energy from heat exchangers (the recovered heat fraction), extras(5);
- Energy content of the produced methane, extras(6).

The energy content of methane is set to 50014 kJ/kg CH₄. To assist the user the software also produce some accumulated energy values:

- Total electricity consumption, extras(7);
- Net heat consumption, extras(8);
- Overall energy production (electricity, heat and energy content of gas) , extras(9).

All these nine energy variables are provided as extra outputs from the digester model (all given in the unit J/year).

At this stage also a special set of energy calculations for a special case study of Hammarby-Sjöstad (using data from Henriksdal's WWTP in Stockholm, Sweden) is coded into the software (Hellström, 2004). This should be removed from the code if the defaults are to be used. With the heat pumps installed for Henriksdal we assume that we recover heat from the digested sludge so that the output temperature of the sludge is equal to the input temperature but that we loose 50% of that heat before it is actually put back into the system (transmission losses, system efficiency etc.). Moreover, we need to put in 1 MJ of electricity into the heat pump system for every 4.5 MJ of heat we recover and put back into the system. So if x MJ is required for heating the sludge without any recovery system we can then put $x/2$ MJ back as heat but we need to put in $x/(2*4.5)$ MJ of electricity. The net heat consumption would be $x/2$ MJ and an extra $x/(2*4.5)$ MJ of electricity is required.

In order to account for the different energy efficiencies for small and large plants a special function is used by which all energy values are multiplied in all models. Note that for the digester model only the mixing and pumping energy is affected by this function as all effects related to heat exchangers and similar equipment is highly specialised. The shape of this function is defined by the user and simply represents the fact that the energy requirements for a small plant is normally higher than that of a large plant per m³ of treated wastewater since large electrical drives are normally more efficient than small ones. The energy adjustment function is further discussed in Chapter 9. The values suggested for the two spADEnergy parameters represent the situation at a large and energy-efficient WWTP.

Case 7.1: Anaerobic digestion (model mode 0)

The proposed AD model is simulated using influent sludge which is first generated by using the URWARE primary sedimentation model (identical to Case 2.2 sludge stream data, only difference is that **spPreSPO4Out** = 1.0). The energy adjustment function is disabled. Traditional heat exchangers are assumed (i.e. not the special Hammarby-Sjöstad implementation). The AD model is simulated using the following set of model parameters:

$$\mathbf{adtemp} = 35 \text{ } ^\circ\text{C}$$

cp = 4200 J/kg/°C
spCODtoBOD = 0.65 mg BOD₇/mg COD_{biodegradable}
fAD_SI = 0.05
fAD_XI = 0.15
fAD_XB = 0.20
fAD_prot = 0.30
fAD_carbo = 0.35
fAD_lipid = 0.35
CODtoCO2 = 0.5
CODtoCH4 = 0.25
modelmode_AD = 0
Nratio_AD = 2
Pratio_AD = 2
Sratio_AD = 2
Pprec_AD = 0.6
Sprec_AD = 0.8
Sgas_AD = 0.1
i_XBK = 0.02
i_XEK = 0.00
CO2inwater_AD = 0.33
heatrecov_AD = 0.35
spADEnergy(1,1) = 3600000 J/m³
spADEnergy(2,1) = 180000 J/m³
spADheatexchanger = true
spADelheatexchanger = 0.2 J/J

spADDEF(1) = 2.5
spADDEF(2) = 2.5
spADDEF(3) = 113
spADDEF(4) = 1.416
spADDEF(5) = 3
spADDEF(6) = 3
spADDEF(7) = 162
spADDEF(8) = 1.185
spADDEF(9) = 17
spADDEF(10) = 40
spADDEF(11) = 884
spADDEF(12) = 2.90
spADDEF(13) = 44
spADDEF(14) = 16

Influent sludge to AD

BOD7 = 23018.6959 g/m³; 395765.608 kg/y; 54.2145 g/cap.day
 COD total = 51923.7047 g/m³; 892735.9153 kg/y; 122.2926 g/cap.day
 COD biosol= 105.205 g/m³; 1808.8133 kg/y; 0.24778 g/cap.day
 COD insol = 29.9945 g/m³; 515.702 kg/y; 0.070644 g/cap.day
 COD biopart = 34418.9886 g/m³; 591773.4 kg/y; 81.0648 g/cap.day
 COD inpart = 17369.5166 g/m³; 298638 kg/y; 40.9093 g/cap.day
 Sum of COD-fractions = 892735.9153 kg/y

The URWARE Wastewater Treatment Plant Models

Volatile solids (VS) = 28824.4375 g/m³; 495585.0267 kg/y; 67.8884 g/cap.day
Suspended solids (TSS) = 39229.0201 g/m³; 674473.3521 kg/y; 92.3936 g/cap.day
Dissolved solids (TS-TSS) = 770.9799 g/m³; 13255.6305 kg/y; 1.8158 g/cap.day
Fixed solids (TS-VS) = 11175.5625 g/m³; 192143.9559 kg/y; 26.3211 g/cap.day
Total solids (TS) = 40000 g/m³; 687728.9826 kg/y; 94.2094 g/cap.day
H₂O = 16505495.5833 kg/y; 2.261 kg/cap.day
Total volume = 17193.2246 m³/y; 47.1047 m³/day
VS content = 2.8824 %
TSS content = 3.9229 %
TS content = 4 %

Total nitrogen = 2666.6896 g/m³; 45848.9934 kg/y; 6.2807 g/cap.day
N-NH₃ & N-NH₄ = 51.9935 g/m³; 893.936 kg/y; 0.12246 g/cap.day
N-NO₃ = 0.072314 g/m³; 1.2433 kg/y; 0.00017032 g/cap.day
N-N₂O = 0 g/m³; 0 kg/y; 0 g/cap.day
N-org,part = 2589.4096 g/m³; 44520.3 kg/y; 6.0987 g/cap.day
N-org,sol = 25.2142 g/m³; 433.5141 kg/y; 0.059385 g/cap.day
Sum of N-fractions = 45848.9934 kg/y
N content per TSS (N-org,part/TSS) = 6.6008 %
N content per TS (Total N/TS) = 6.6667 %

Total sulphur = 119.2472 g/m³; 2050.2439 kg/y; 0.28086 g/cap.day
SO₄-S = 2.6539 g/m³; 45.6293 kg/y; 0.0062506 g/cap.day
S particulate = 115.2663 g/m³; 1981.8 kg/y; 0.27148 g/cap.day
Sulfide HS-S = 1.327 g/m³; 22.8146 kg/y; 0.0031253 g/cap.day
Sum of S-fractions = 2050.2439 kg/y
S content per TSS (S particulate/TSS) = 0.29383 %
S content per TS (Total S/TS) = 0.29812 %

Total phosphorus = 915.4226 g/m³; 15739.0659 kg/y; 2.156 g/cap.day
PO₄-P = 0.99981 g/m³; 17.19 kg/y; 0.0023548 g/cap.day
P particulate = 914.4228 g/m³; 15721.8759 kg/y; 2.1537 g/cap.day
Sum of P-fractions = 15739.0659 kg/y
P content per TSS (P particulate/TSS) = 2.331 %
P content per TS (Total P/TS) = 2.2886 %

Total potassium = 104.7847 g/m³; 1801.5869 kg/y; 0.24679 g/cap.day
Dissolved potassium = 18.8061 g/m³; 323.3369 kg/y; 0.044293 g/cap.day
Organically bound potassium = 85.9786 g/m³; 1478.25 kg/y; 0.2025 g/cap.day
K content per TSS (Organically bound K/TSS) = 0.21917 %
K content per TS (Total K/TS) = 0.26196 %
Temperature in water = 20 degC

Output sludge from AD

BOD₇ = 4547.1782 g/m³; 76930.542 kg/y; 10.5384 g/cap.day
COD total = 31673.5693 g/m³; 535863.062 kg/y; 73.4059 g/cap.day
COD biosol = 0 g/m³; 0 kg/y; 0 g/cap.day
COD insol = 1779.3966 g/m³; 30104.372 kg/y; 4.1239 g/cap.day
COD biopart = 6995.6588 g/m³; 118354.68 kg/y; 16.213 g/cap.day
COD inpart = 22898.5139 g/m³; 387404.01 kg/y; 53.069 g/cap.day
Sum of COD-fractions = 535863.062 kg/y

Volatile solids (VS) = 14646.416 g/m³; 247792.5134 kg/y; 33.9442 g/cap.day
Suspended solids (TSS) = 22644.3898 g/m³; 383104.6626 kg/y; 52.4801 g/cap.day
Dissolved solids (TS-TSS) = 1755.6945 g/m³; 29703.3718 kg/y; 4.069 g/cap.day
Fixed solids (TS-VS) = 9753.6683 g/m³; 165015.5211 kg/y; 22.6049 g/cap.day
Total solids (TS) = 24400.0843 g/m³; 412808.0344 kg/y; 56.549 g/cap.day

The URWARE Wastewater Treatment Plant Models

H₂O = 16505495.5833 kg/y; 2.261 kg/cap.day
Total volume = 16918.3036 m³/y; 46.3515 m³/day
VS content = 1.465 %
TSS content = 2.2644 %
TS content = 2.44 %

Total nitrogen = 2709.9496 g/m³; 45847.7501 kg/y; 6.2805 g/cap.day
N-NH₃ & N-NH₄ = 1576.2679 g/m³; 26667.7784 kg/y; 3.6531 g/cap.day
N-NO₃ = 0 g/m³; 0 kg/y; 0 g/cap.day
N-N₂O = 0 g/m³; 0 kg/y; 0 g/cap.day
N-org,part = 1108.0578 g/m³; 18746.4576 kg/y; 2.568 g/cap.day
N-org,sol = 25.624 g/m³; 433.5141 kg/y; 0.059385 g/cap.day
Sum of N-fractions = 45847.7501 kg/y
N content per TSS (N-org,part/TSS) = 4.8933 %
N content per TS (Total N/TS) = 11.1063 %

Total sulphur = 119.7478 g/m³; 2025.9288 kg/y; 0.27752 g/cap.day
SO₄-S = 0 g/m³; 0 kg/y; 0 g/cap.day
S particulate = 106.8129 g/m³; 1807.0931 kg/y; 0.24755 g/cap.day
Sulfide HS-S = 12.9349 g/m³; 218.8358 kg/y; 0.029978 g/cap.day
Sum of S-fractions = 2025.9288 kg/y
S content per TSS (S particulate/TSS) = 0.4717 %
S content per TS (Total S/TS) = 0.49077 %

Total phosphorus = 930.2981 g/m³; 15739.0659 kg/y; 2.156 g/cap.day
PO₄-P = 215.5997 g/m³; 3647.5806 kg/y; 0.49967 g/cap.day
P particulate = 714.6984 g/m³; 12091.4853 kg/y; 1.6564 g/cap.day
Sum of P-fractions = 15739.0659 kg/y
P content per TSS (P particulate/TSS) = 3.1562 %
P content per TS (Total P/TS) = 3.8127 %

Total potassium = 106.4874 g/m³; 1801.5869 kg/y; 0.24679 g/cap.day
Dissolved potassium = 75.2073 g/m³; 1272.3798 kg/y; 0.1743 g/cap.day
Organically bound potassium = 31.2802 g/m³; 529.2071 kg/y; 0.072494 g/cap.day
K content per TSS (Organically bound K/TSS) = 0.13814 %
K content per TS (Total K/TS) = 0.43642 %
Temperature in water = 20 degC

Extra output variables from AD

Energy consumption (mixing) = 61895.6084 MJ/y; 17193.2246 kWh/y
Energy consumption (pumping) = 3045.2947 MJ/y; 845.9152 kWh/y
Energy consumption (heat exchanger) = 75822.1203 MJ/y; 21061.7001 kWh/y
Energy consumption (heating) = 1083173.1477 MJ/y; 300881.4299 kWh/y
Heat energy recovered (heat exchanger) = 379110.6017 MJ/y; 105308.5005 kWh/y
Energy content of produced methane = 4462159.7212 MJ/y; 1239488.8114 kWh/y
Total electrical energy consumption = 140763.0234 MJ/y; 39100.8398 kWh/y
Total heat consumption = 704062.546 MJ/y; 195572.9294 kWh/y
Total energy production = 3617334.1518 MJ/y; 1004815.0422 kWh/y
CO₂ gas production = 119552.4059 kg CO₂/y = 2717.1001 kmole/y
CH₄ gas production = 89218.2133 kg CH₄/y = 5576.1383 kmole/y = 124432.6546 Nm³/y = 356872.8533 kg COD/y
H₂S gas production = 24.3151 kg H₂S-S/y = 0.75985 kmole/y
N₂ gas production = 1.2433 kg N₂/y = 0.044404 kmole/y
Molar relationship in gas: CH₄ = 67.2306%; CO₂ = 32.7597%; H₂S = 0.0091614%; N₂ = 0.00053537%

In this case the defined amount of potassium in the particulate biodegradable material was not possible to achieve ($i_XBK = 0.02$) if the mass balance should be fulfilled (not enough K in the influent). However, the model detected this and suggested a solution similar to the principle used for N, P and S (with ratio by default = 3) and the inconsistency was resolved (see code in Appendix R for how the model handles this type of problem). Some of the values related to energy can be discussed and is provided more as an example of the type of output the model provides.

In the case no heat exchangers were used the extra output variables from the digester would instead be:

Energy consumption (mixing) = 61895.6084 MJ/y; 17193.2246 kWh/y
 Energy consumption (pumping) = 3045.2947 MJ/y; 845.9152 kWh/y
 Energy consumption (heat exchanger) = 0 MJ/y; 0 kWh/y
 Energy consumption (heating) = 1083173.1477 MJ/y; 300881.4299 kWh/y
 Heat energy recovered (heat exchanger) = 0 MJ/y; 0 kWh/y
 Energy content of produced methane = 4462159.7212 MJ/y; 1239488.8114 kWh/y
 Total electrical energy consumption = 64940.9031 MJ/y; 18039.1397 kWh/y
 Total heat consumption = 1083173.1477 MJ/y; 300881.4299 kWh/y
 Total energy production = 3314045.6705 MJ/y; 920568.2418 kWh/y
 CO₂ gas production = 119552.4059 kg CO₂/y = 2717.1001 kmole/y
 CH₄ gas production = 89218.2133 kg CH₄/y = 5576.1383 kmole/y = 124432.6546 Nm³/y = 356872.8533 kg COD/y
 H₂S gas production = 24.3151 kg H₂S-S/y = 0.75985 kmole/y
 N₂ gas production = 1.2433 kg N₂/y = 0.044404 kmole/y
 Molar relationship in gas: CH₄ = 67.2306%; CO₂ = 32.7597%; H₂S = 0.0091614%; N₂ = 0.00053537%
 Temperature in output sludge = 35 degC

Case 7.2: Simulation comparison with IWA ADM1 model

In order to demonstrate that the behaviour of the anaerobic digestion model is reasonable, a comparative simulation is done using the state-of-the-art ADM1 (Batstone *et al.*, 2002). This model is highly complex and does not use the same set of variables as for example the ASM1 model or URWARE. Consequently, the input data must be transformed using a special conversion program (Copp *et al.*, 2003). An alternative conversion algorithm is presented by Vanrolleghem *et al.* (2004). The influent sludge to the AD is first generated by using the URWARE presedimentation model (identical to Case 2.2 sludge stream data, the only difference is that **spPreSPO4Out** = 1.0). From this data, the variables that are relevant for the ASM1 model are extracted (basically COD and nitrogen variables) and then these data are transformed into their ADM1 equivalents. The ADM1 was simulated at 37 °C compared to 35 °C for the URWARE model.

Influent sludge (from URWARE presedimentation model)

BOD₇ = 23018.6959 g/m³; 395765.608 kg/y; 54.2145 g/cap.day
 COD total = 51923.7047 g/m³; 892735.9153 kg/y; 122.2926 g/cap.day
 COD biosol = 105.205 g/m³; 1808.8133 kg/y; 0.24778 g/cap.day
 COD insol = 29.9945 g/m³; 515.702 kg/y; 0.070644 g/cap.day
 COD biopart = 34418.9886 g/m³; 591773.4 kg/y; 81.0648 g/cap.day
 COD inpart = 17369.5166 g/m³; 298638 kg/y; 40.9093 g/cap.day
 Sum of COD-fractions = 892735.9153 kg/y

The URWARE Wastewater Treatment Plant Models

Volatile solids (VS) = 28824.4375 g/m³; 495585.0267 kg/y; 67.8884 g/cap.day
Suspended solids (TSS) = 39229.0201 g/m³; 674473.3521 kg/y; 92.3936 g/cap.day
Dissolved solids (TS-TSS) = 770.9799 g/m³; 13255.6305 kg/y; 1.8158 g/cap.day
Fixed solids (TS-VS) = 11175.5625 g/m³; 192143.9559 kg/y; 26.3211 g/cap.day
Total solids (TS) = 40000 g/m³; 687728.9826 kg/y; 94.2094 g/cap.day
H₂O = 16505495.5833 kg/y; 2.261 kg/cap.day
Total volume = 17193.2246 m³/y; 47.1047 m³/day
VS content = 2.8824 %
TSS content = 3.9229 %
TS content = 4 %

Total nitrogen = 2666.6896 g/m³; 45848.9934 kg/y; 6.2807 g/cap.day
N-NH₃ & N-NH₄ = 51.9935 g/m³; 893.936 kg/y; 0.12246 g/cap.day
N-NO₃ = 0.072314 g/m³; 1.2433 kg/y; 0.00017032 g/cap.day
N-N₂O = 0 g/m³; 0 kg/y; 0 g/cap.day
N-org,part = 2589.4096 g/m³; 44520.3 kg/y; 6.0987 g/cap.day
N-org,sol = 25.2142 g/m³; 433.5141 kg/y; 0.059385 g/cap.day
Sum of N-fractions = 45848.9934 kg/y
N content per TSS (N-org,part/TSS) = 6.6008 %
N content per TS (Total N/TS) = 6.6667 %

Total sulphur = 119.2472 g/m³; 2050.2439 kg/y; 0.28086 g/cap.day
SO₄-S = 2.6539 g/m³; 45.6293 kg/y; 0.0062506 g/cap.day
S particulate = 115.2663 g/m³; 1981.8 kg/y; 0.27148 g/cap.day
Sulfide HS-S = 1.327 g/m³; 22.8146 kg/y; 0.0031253 g/cap.day
Sum of S-fractions = 2050.2439 kg/y
S content per TSS (S particulate/TSS) = 0.29383 %
S content per TS (Total S/TS) = 0.29812 %

Total phosphorus = 915.4226 g/m³; 15739.0659 kg/y; 2.156 g/cap.day
PO₄-P = 0.99981 g/m³; 17.19 kg/y; 0.0023548 g/cap.day
P particulate = 914.4228 g/m³; 15721.8759 kg/y; 2.1537 g/cap.day
Sum of P-fractions = 15739.0659 kg/y
P content per TSS (P particulate/TSS) = 2.331 %
P content per TS (Total P/TS) = 2.2886 %

Total potassium = 104.7847 g/m³; 1801.5869 kg/y; 0.24679 g/cap.day
Dissolved potassium = 18.8061 g/m³; 323.3369 kg/y; 0.044293 g/cap.day
Organically bound potassium = 85.9786 g/m³; 1478.25 kg/y; 0.2025 g/cap.day
K content per TSS (Organically bound K/TSS) = 0.21917 %
K content per TS (Total K/TS) = 0.26196 %
Temperature in water = 20 degC

Extraction of ASM1 relevant variables (from URWARE presedimentation model sludge out)

Si = soluble inert organic material (g COD/m³) = 29.9945
Ss = readily biodegradable substrate (g COD/m³) = 105.205
Xi = particulate inert organic material (g COD/m³) = 17369.5166
Xs = slowly biodegradable substrate (g COD/m³) = 34418.9886
Xbh = active heterotrophic biomass (g COD/m³) = 0
Xba = active autotrophic biomass (g COD/m³) = 0
Xp = particulate product arising from biomass decay (g COD/m³) = 0
So = oxygen (g -COD/m³) = 0
Sno = nitrate and nitrite nitrogen (g N/m³) = 0.072314
Snh = ammonia and ammonium nitrogen (g N/m³) = 51.9935
Snd = soluble biogradable organic nitrogen (g N/m³) = 23.4145
Xnd = particulate biogradable organic nitrogen (g N/m³) = 1547.2386
Salk = alkalinity (mole HCO₃-/m³) = 7
Volume flow rate = 47.1047 m³/day

Total suspended solids (TSS) = 38840 g/m³ (particulate COD * 0.75)
 Total COD input (mg COD/l) not including O₂ = 51923.7047
 of which COD removed due to influent O₂ and NO₃ (mg COD/l) = 0.20682
 Total TKN input (mg N/l) = 2664.8176
 N removed due to denitrification of NO₃ (mg N/l) = 0.072314

Note that the nitrogen associated with inert COD fractions is not explicitly given. It is, however, included in the total TKN value. Flow, temperature, etc are naturally identical to values prior to this conversion.

Conversion into ADM1 variables (sludge input)

Ssu = monosacharides (kg COD/m³) = 0
 Saa = amino acids (kg COD/m³) = 0.105
 Sfa = long chain fatty acids (LCFA) (kg COD/m³) = 0
 Sva = total valerate (kg COD/m³) = 0
 Sbu = total butyrate (kg COD/m³) = 0
 Spro = total propionate (kg COD/m³) = 0
 Sac = total acetate (kg COD/m³) = 0
 Sh₂ = hydrogen gas (kg COD/m³) = 0
 Sch₄ = methane gas (kg COD/m³) = 0
 Sic = inorganic carbon (kmole C/m³) = 0.007
 Sin = inorganic nitrogen (kmole N/m³) = 0.02399 (= 0.33586 kg N/m³)
 Si = soluble inerts (kg COD/m³) = 0.029995
 Xc = composites (kg COD/m³) = 35.2875
 Xch = carbohydrates (kg COD/m³) = 0
 Xpr = proteins (kg COD/m³) = 0
 Xli = lipids (kg COD/m³) = 0
 Xsu = sugar degraders (kg COD/m³) = 0
 Xaa = amino acid degraders (kg COD/m³) = 0
 Xfa = LCFA degraders (kg COD/m³) = 0
 Xc₄ = valerate and butyrate degraders (kg COD/m³) = 0
 Xpro = propionate degraders (kg COD/m³) = 0
 Xac = acetate degraders (kg COD/m³) = 0
 Xh₂ = hydrogen degraders (kg COD/m³) = 0
 Xi = particulate inerts (kg COD/m³) = 16.501
 Scat = cations (kmole/m³) = 0.042
 San = anions (kmole/m³) = 0.02399
 Total COD (mg COD/l) = 51923.4979
 Total TKN (mg N/l) = 2664.8176
 Influent flow rate = 47.1047 m³/d
 Suspended solids concentration in influent = 3.8841%

The above input data is fed into the ADM1 model using a standard set of model parameters. The liquid volume of the reactor is set to 942 m³ (i.e. a hydraulic retention time of 20 days). The process is simulated until a steady-state solution is available. The results of the ADM1 system (using its own set of model variables) are given below.

ADM1 output variables (steady state solution)

Ssu = monosacharides (kg COD/m³) = 0.011969
 Saa = amino acids (kg COD/m³) = 0.0053538
 Sfa = long chain fatty acids (LCFA) (kg COD/m³) = 0.10266
 Sva = total valerate (kg COD/m³) = 0.010776
 Sbu = total butyrate (kg COD/m³) = 0.01424
 Spro = total propionate (kg COD/m³) = 0.016848
 Sac = total acetate (kg COD/m³) = 0.051461
 Sh₂ = hydrogen gas in liquid (kg COD/m³) = 2.4185e-07

Sch4 = methane gas in liquid (kg COD/m3) = 0.047333
 SIC = inorganic carbon (kmole C/m3) = 0.081529
 SIN = inorganic nitrogen (kmole N/m3) = 0.054931 (= 0.76904 kg N/m3)
 Si = soluble inerts (kg COD/m3) = 3.3215
 Xc = composites (kg COD/m3) = 3.2918
 Xch = carbohydrates (kg COD/m3) = 0.032755
 Xpr = proteins (kg COD/m3) = 0.032755
 Xli = lipids (kg COD/m3) = 0.049132
 Xsu = sugar degraders (kg COD/m3) = 0.50213
 Xaa = amino acid degraders (kg COD/m3) = 0.38001
 Xfa = LCFA degraders (kg COD/m3) = 0.39565
 Xc4 = valerate and butyrate degraders (kg COD/m3) = 0.16266
 Xpro = propionate degraders (kg COD/m3) = 0.077317
 Xac = acetate degraders (kg COD/m3) = 0.527
 Xh2 = hydrogen degraders (kg COD/m3) = 0.25446
 Xi = particulate inerts (kg COD/m3) = 23.0841
 Scat = cations (kmole/m3) = 0.042
 San = anions (kmole/m3) = 0.02399
 Sva- = base form of Sva (kg COD/m3) = 0.01072
 Sbu- = base form of Sbu (kg COD/m3) = 0.014172
 Spro- = base form of Spro (kg COD/m3) = 0.016756
 Sac- = base form of Sac (kg COD/m3) = 0.051246
 Shco3- = carbonate part of SIC (kmole C/m3) = 0.071028
 Snh3 = ammonia part of SIN (kmole N/m3) = 0.00082243
 Sh2_gas = hydrogen in gas phase (kg COD/m3) = 1.0831e-05
 Sch4_gas = methane in gas phase (kg COD/m3) = 1.4282
 Sco2_gas = carbon dioxide in gas phase (kmole/m3) = 0.015049
 Sco2 = carbon dioxide part of SIC (kmole C/m3) = 0.0105
 Snh4+ = ammonium part of SIN (kmole N/m3) = 0.054109
 P_gas_h2 = partial gas pressure of H2 (bar) = 1.7343e-05
 P_gas_ch4 = partial gas pressure of CH4 (bar) = 0.57172
 P_gas_co2 = partial gas pressure of CO2 (bar) = 0.38556
 q_gas = gas flow from AD reactor (m3/d) = 644.8368
 Sh+ = hydrogen ions (kmole H+/m3) = 7.3029e-08
 pH in AD liquid phase = 7.1365
 Total COD output (mg COD/l) except CH4 and H2 = 32324.6124
 COD from CH4 and H2 is stripped upon reentry (mg COD/l) = 47.3332
 Total TKN output (mg N/l) = 2664.8176
 Output flow from AD (m3/d) = 47.1047

In order to reduce the number of variables we use another program for transforming ADM1 variables into ASM1 variables (Copp *et al.*, 2003). This transformation only takes into account the output sludge flow whereas gas related variables should be found in the ADM1 output variables.

Transforming ADM1 output sludge variables into ASM1 variables

Si = soluble inert organic material (g COD/m3) = 3321.5154
 Ss = readily biodegradable substrate (g COD/m3) = 213.3097
 Xi = particulate inert organic material (g COD/m3) = 23084.0825
 Xs = slowly biodegradable substrate (g COD/m3) = 5705.7047
 Xbh = active heterotrophic biomass (g COD/m3) = 0
 Xba = active autotrophic biomass (g COD/m3) = 0
 Xp = particulate product arising from biomass decay (g COD/m3) = 0
 So = oxygen (g -COD/m3) = 0
 Sno = nitrate and nitrite nitrogen (g N/m3) = 0
 Snh = ammonia and ammonium nitrogen (g N/m3) = 769.0365
 Snd = soluble biodegradable organic nitrogen (g N/m3) = 199.8156
 Xnd = particulate biodegradable organic nitrogen (g N/m3) = 310.9206

Salk = alkalinity (mole HCO₃⁻/m³) = 81.5285
 Total COD output (mg COD/l) = 32324.6124
 Total TKN output (mg N/l) = 2664.8176
 Output flow from AD (m³/d) = 47.1047

Note again that the nitrogen associated with inert COD is not given explicitly but is included in the total TKN value. All output biomass from the AD is assumed to die as it is exposed to an aerobic environment and is therefore included as part of the slowly biodegradable substrate.

Finally, we can transform some of the outputs back into URWARE variables for easy comparison with the outputs of the URWARE anaerobic digestion model. Naturally the number of variables that can be compared is limited but will certainly provide important information about the behaviour of the two models.

Output sludge from AD (transformed into URWARE variables), URWARE results in ()

BOD₇ = 3847.36 g/m³ (factor 0.65 times biodegradable COD) (4547 g/m³)
 COD total = 32324.6124 g/m³ (31674 g/m³)
 COD biosol = 213.3097 g/m³ (0 g/m³)
 COD insol = 3321.5154 g/m³ (1779 g/m³)
 COD biopart = 5705.7047 g/m³ (6996 g/m³)
 COD inpart = 23084.0825 g/m³ (22899 g/m³)

Suspended solids (TSS) = 21592.34 g/m³ (factor 0.75 times particulate COD) (22644 g/m³)
 Total flow = 47.1047 m³/day (46.35 m³/d)
 TSS content = 2.159 % (2.26%)

Total nitrogen = 2664.8176 g/m³ (2710 g/m³)
 N-NH₃ & N-NH₄ = 769.0365 g/m³ (1576 g/m³)
 N-NO₃ = 0.0 g/m³ (0 g/m³)
 N-org,part = 1695.9656 g/m³ (1108 g/m³)
 N-org,sol = 199.8156 g/m³ (26 g/m³)

It is certainly rewarding that after all the above calculations and transformations the results are fairly similar to the simple URWARE AD model. This also holds for the gas production, which was given previously (for example 83950 kg CH₄/year in ADM1 and 89200 kg CH₄/year in URWARE, 109000 kg CO₂/year in ADM1 and 119500 kg CO₂/year in URWARE). All these numbers require detailed further analysis. The ammonia concentrations are quite different and therefore also N_{org,part} and the concentration of soluble inert COD in the ADM1 is considerably higher (unrealistically high actually). By increasing the value of **fAD_SI** in the URWARE AD model from 0.05 to 0.1 we can produce almost identical amounts of gas in the two models and also soluble inert COD would be very similar. Then only the difference in ammonia vs. N_{org,part} remains. However, since the ADM1 only handles inorganic nitrogen (total and NH₄) it is the transformation interface that actually determines the amount of N_{org,part} and therefore this value is quite uncertain. It would also be very easy to include a fraction of

the nitrogen as associated to inert soluble COD (as the ADM1 does) and thereby increase the N_{org_sol} value of the URWARE AD model. However, the output total COD, total N and TSS are very similar in the two models.

8

Combining the modules into a general WWT plant

In the previous chapters, the different basic modules required to describe a 'normal' WWTP have been described and to some extent validated. However, the overall aim is that the models shall produce relevant and correct output data when working together taking into account the different recirculations etc. within the entire plant. To demonstrate the general behaviour of the URWARE models we create a plant partly based on the Henriksdal WWTP (Stockholm, Sweden) layout and use an influent wastewater with characteristics similar to what is to be expected from the Hammarby-Sjöstad area (although the ammonia load has been reduced by 30% to have a more 'traditional' wastewater). The water from Hammarby-Sjöstad is very highly concentrated compared to most municipal wastewaters (in particular the ammonia concentration), which is a result of water efficient households, negligible in-leakage in the proposed new pipe system and not much stormwater. Only 160 l of wastewater/person.day reaches the plant and, consequently, most concentrations are higher than what is usually encountered. Obviously this has effects also within the plant when studying the results.

In Figure 8.1 below, the principle model layout of the WWTP is shown and then the specifications of the different models are given. The internal layout of the activated sludge block is identical to the one shown in Figure 6.1. Finally, a large number of results are given in order to provide data for the interested reader to examine the wastewater characteristics in many different locations throughout the plant. The main message of this chapter is that the models work well when put together and give reasonable results. However, a significant amount of information about the true processes must be gathered if the models are to produce outputs close to actual measurements for a specific plant.

The modelled plant is fairly traditional. The influent wastewater enters a primary clarifier where pre-precipitation of phosphate is carried out. The water then enters an activated sludge system, which is a pre-denitrification system with a hydraulic retention time of about 15 h and a sludge age of about 15 days (33% anoxic volume and 67% aerobic volume, concentration of dissolved oxygen 2.5 mg/l). The effluent water is finally polished in a sand filter (including P-precipitation) prior to being released into the

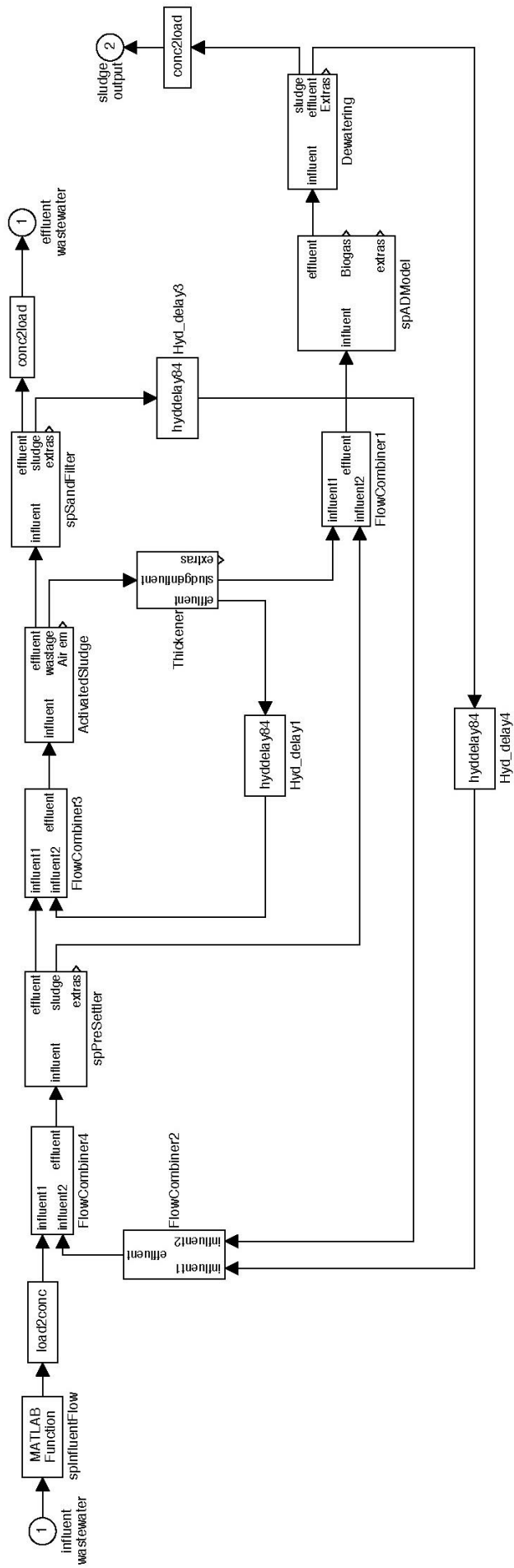

Figure 8.1
Schematic plant layout
of an URWARE WWTP
model in Simulink.

recipient. The sludge removed in the primary clarifier and from the activated sludge settler is thickened to about 4% TSS and then digested in a mesophilic system with a retention time of 20 days. Finally, the digested sludge is dewatered to a TS level of 30%. The reject water from the dewatering process is recycled back to the primary clarifier together with the backwash water from the sand filter and the effluent water from the thickener for the activated sludge wastage is recycled back into the activated sludge system. No external carbon source is activated but organic polymers are added in the dewatering process. The special type of heat pumps for the digester (see Chapter 7) are used and the energy adjustment function is disabled. The temperature of the influent wastewater is set to 12 °C.

The results are not further commented upon but available for the interested reader who wants an overview of the results produced by a simulation of a complete WWTP.

Simulated URWARE WWT plant model specifications in detail
Model parameters for primary sedimentation:

spPreSSludgeTSPerc = 0.04 (4%)
spPreSRed = 0.6 (60%)
spPreSFeCl3In = 0.2 (g FeCl3/g solution)
spPreSPO4Out = 2 mg P/l (i.e. < PO4-P in, precipitation)
spCODtoVS(1,1) = 1/1.42 (g VS/g COD_biodeg)
spCODtoVS(2,1) = 1/1.9 (g VS/g COD_inert)
spPreSMode = 1
spPreSEnergy(1,1) = 5400 J/m³
spPreSEnergy(2,1) = 5400 J/m³
spPreSEnergy(3,1) = 180000 J/m³

Model parameters for the activated sludge system

The conversion of the wastewater variables when entering the activated sludge system is carried out as described in Section 6.1.

Model parameters for the anoxic reactor:

spASHydRetTime = 0.65 days
spASAnoxFrac = 33%
spASAnoxExtCFlow = 0 m³/d
spASAnoxIntRecFrac = 0%
spCODtoBOD = 0.65 mg BOD₇/mg COD_biodegradable
spCODtoVS(1,1) = 1/1.42 ≈ 0.704
spCODtoVS(2,1) = 1/1.9 ≈ 0.526
spCODtoSS(1,1) = 0.75 g SS/g COD
spCODtoSS(2,1) = 0.9 g SS/g COD
spASAnoxExtCConc = 100000 g/m³
spASSludgeAge = 15.4 days
spASAnoxEnergy(1,1): 2.5 W/m³ of anoxic reactor volume
spASAnoxEnergy(2,1): 72000 J/m³ (20 Wh/m³) of pumped flow
spASAnoxEnergy(3,1): 1800000 J/kg O₂ (500 Wh/kg O₂)

Y_A = 0.24
Y_H = 0.67
f_P = 0.08
i_XB = 0.086
i_XE = 0.06
mu_H = 6.0
K_S = 20
K_OH = 0.2
K_NO = 0.5
b_H_anox = b_H_aerob/2
ny_g = 0.8
ny_h = 0.4
k_h = 3.0
K_X = 0.03
mu_A = 0.8
K_NH = 1
K_OA = 0.4
k_a = 0.08
b_A_anox = b_A_aerob/3
K_P = 0.05
i_XBP = 0.02
i_XEP = 0.01
K_K = 0.05
i_XBK = 0.02
i_XEK = 0.0
b_H_aerob = 0.62
b_A_aerob = 0.2
K_NH_lim = 0.1
K_sulf_lim = 0.05
i_Xsulf = 0.0021
N2O_frac_denitri = 0.0005
K_sulf = 0.5

Model parameters for the aerobic reactor:

spASHydRetTime = 0.65 days
spASAerobFrac = 67%
spASAerobSOlevel = 2.5 mg/l
spASAerobIntRecFrac = 450%
spCODtoBOD = 0.65 mg BOD₇/mg COD_{biodegradable}
spCODtoVS(1,1) = 1/1.42 ≈ 0.704
spCODtoVS(2,1) = 1/1.9 ≈ 0.526
spCODtoSS(1,1) = 0.75 g SS/g COD
spCODtoSS(2,1) = 0.9 g SS/g COD
spASAerobAirEff = 0.67
spASSludgeAge = 15.4 days
spASAerobEnergy(1,1): 0 W/m³
spASAerobEnergy(2,1): 72000 J/m³ (20 Wh/m³) of pumped flow
spASAerobEnergy(3,1): 1800000 J/kg O₂ (500 Wh/kg O₂)

Y_A = 0.24
Y_H = 0.67
f_P = 0.08
i_XB = 0.086
i_XE = 0.06
mu_H = 6.0
K_S = 20
K_OH = 0.2
K_NO = 0.5
b_H_anox = **b_H_aerob**/2
ny_g = 0.8
ny_h = 0.4
k_h = 3.0
K_X = 0.03
mu_A = 0.8
K_NH = 1
K_OA = 0.4
k_a = 0.08
b_A_anox = **b_A_aerob**/3
K_P = 0.05
i_XBP = 0.02
i_XEP = 0.01
K_K = 0.05
i_XBK = 0.02
i_XEK = 0.0
b_H_aerob = 0.62
b_A_aerob = 0.2
K_NH_lim = 0.1
K_sulf_lim = 0.05
i_Xsulf = 0.0021
N2O_frac_nitri = 0.0003
K_sulf = 0.5

Model parameters for the activated sludge settler:

SpASHydRetTime = 0.65 days
spASSludgeAge = 15.4 days
spASRecycleFrac = 50%
spASWastageFrac = 1.3%
spCODtoBOD = 0.65 mg BOD₇/mg COD_{biodegradable}
spCODtoVS(1,1) = 1/1.42 (g VS/g COD_{biodegradable})
spCODtoVS(2,1) = 1/1.9 (g VS/g COD_{inert})
f_P_true = $f_P / (1 - Y_H + Y_H * f_P)$ = 0.2086
spASIdealSEnergy(1,1): 5400 J/m³ of influent flow (= 1.5 Wh/m³)
spASIdealSEnergy(2,1): 180000 J/m³ of pumped flow (= 50 Wh/m³)

Model parameters for sand filter:

spFiltSludgeTSPerc = 0.04 (4%) – not in use in mode 0

spFiltSSOut = 2 mg TSS/l
spFiltFeCl3In = 0.2 (g FeCl3/g solution)
spFiltPO4Out = 0.1 mg PO4-P/l (i.e. < PO4-P in, active precip.)
spCODtoVS(1,1) = 1/1.42 (g VS/g COD_biodegradable)
spCODtoVS(2,1) = 1/1.9 (g VS/g COD_inert)
spFiltMode = 0 (i.e. only sand filtration unit)
spFiltBackwash = 0.05 (5% of original input volume)
spFiltEnergy(1,1): 5400 J/m³ of influent flow (= 1.5 Wh/m³)
spFiltEnergy(2,1): 5400 J/m³ of influent flow (= 1.5 Wh/m³)
spFiltEnergy(3,1): 180000 J/m³ of pumped flow (= 50 Wh/m³)
spFiltEnergy(4,1): 36000 J/m³ of influent flow (= 10 Wh/m³)

Model parameters for thickener:

SpThickSludgeTSPerc = 0.04 (4%)
SpThickRed = 0.80 (80%)
spCODtoVS(1,1) = 1/1.42 (g VS/g COD_biodegradable)
spCODtoVS(2,1) = 1/1.9 (g VS/g COD_inert)
spThickEnergy(1,1): 5400 J/m³ of influent flow (= 1.5 Wh/m³)
spThickEnergy(2,1): 180000 J/m³ of pumped flow (= 50 Wh/m³)

Model parameters for anaerobic digester:

adtemp = 35 °C
cp = 4200 J/kg/°C
spCODtoBOD = 0.65 mg BOD₇/mg COD_biodegradable
fAD_SI = 0.05
fAD_XI = 0.15
fAD_XB = 0.20
fAD_prot = 0.30
fAD_carbo = 0.35
fAD_lipid = 0.35
CODtoCO2 = 0.5
CODtoCH4 = 0.25
modelmode_AD = 0
Nratio_AD = 2
Pratio_AD = 2
Sratio_AD = 2
Pprec_AD = 0.6
Sprec_AD = 0.8
Sgas_AD = 0.1
i_XBK = 0.02
i_XEK = 0.00
CO2inwater_AD = 0.33
heatrecov_AD: 0.35 (not used due to special energy recovery)
spADEnergy(1,1): 3600000 J/m³ of influent sludge (1 kWh/m³)
spADEnergy(2,1): 180000 J/m³ of pumped flow (50 Wh/m³)
spADheatexchanger: true (not used due to special energy recovery)
spADelheatexchanger: 0.2 (not used due to special energy recovery)
spADDEF(1) = 2.5

spADDEF(1) = 2.5
spADDEF(3) = 113
spADDEF(4) = 1.416
spADDEF(5) = 3
spADDEF(6) = 3
spADDEF(7) = 162
spADDEF(8) = 1.185
spADDEF(9) = 17
spADDEF(10) = 40
spADDEF(11) = 884
spADDEF(12) = 2.90
spADDEF(13) = 44
spADDEF(14) = 16

Model parameters for dewatering process:

spDewSludgeTSPerc = 0.30 (30%)
spDewRed = 0.90 (95%)
spDewPolyIn = 0.001
spDewPolyRatio = 0.005 (5 kg/ton TS - activated)
spCODtoVS(1,1) = 1/1.42 (g VS/g COD_biodegradable)
spCODtoVS(2,1) = 1/1.9 (g VS/g COD_inert)
spDewEnergy: 5200000 J/m³ (= 1.44 kWh/m³) of influent flow

Results from full WWT plant simulation using URWARE

Influent wastewater to WWT plant

BOD7 = 362.4387 g/m³; 412561.325 kg/y; 56.5153 g/cap.day
 COD total = 807.7045 g/m³; 919404.048 kg/y; 125.9458 g/cap.day
 COD biosol= 273.2307 g/m³; 311016.5 kg/y; 42.605 g/cap.day
 COD insol = 53.5038 g/m³; 60903.024 kg/y; 8.3429 g/cap.day
 COD biopart = 236.4515 g/m³; 269151 kg/y; 36.87 g/cap.day
 COD inpart = 244.5184 g/m³; 278333.524 kg/y; 38.1279 g/cap.day
 Sum of COD-fractions = 919404.048 kg/y

Volatile solids (VS) = 572.691 g/m³; 651890 kg/y; 89.3 g/cap.day
 Suspended solids (TSS) = 421.7263 g/m³; 480048 kg/y; 65.76 g/cap.day
 Dissolved solids (TS-TSS) = 545.2545 g/m³; 620659.14 kg/y; 85.0218 g/cap.day
 Fixed solids (TS-VS) = 394.2898 g/m³; 448817.14 kg/y; 61.4818 g/cap.day
 Total solids (TS) = 966.9808 g/m³; 1100707.14 kg/y; 150.7818 g/cap.day
 H2O = 1137191942.86 kg/y; 155.7797 kg/cap.day
 Total volume = 1138292.65 m³/y; 3118.61 m³/day
 VS content = 0.057269 %
 TSS content = 0.042173 %
 TS content = 0.096698 %

Total nitrogen = 66.9953 g/m³; 76260.2266 kg/y; 10.4466 g/cap.day
 N-NH3 & N-NH4 = 50.5686 g/m³; 57561.8168 kg/y; 7.8852 g/cap.day
 N-NO3 = 0.31377 g/m³; 357.1598 kg/y; 0.048926 g/cap.day
 N-N2O = 0 g/m³; 0 kg/y; 0 g/cap.day
 N-org,part = 7.0705 g/m³; 8048.25 kg/y; 1.1025 g/cap.day
 N-org,sol = 9.0425 g/m³; 10293 kg/y; 1.41 g/cap.day
 Sum of N-fractions = 76260.2266 kg/y

The URWARE Wastewater Treatment Plant Models

N content per TSS (N-org,part/TSS) = 1.6766 %
N content per TS (Total N/TS) = 6.9283 %

Total sulphur = 19.2304 g/m³; 21889.78 kg/y; 2.9986 g/cap.day
SO₄-S = 17.316 g/m³; 19710.73 kg/y; 2.7001 g/cap.day
S particulate = 1.2538 g/m³; 1427.15 kg/y; 0.1955 g/cap.day
Sulfide HS-S = 0.66055 g/m³; 751.9 kg/y; 0.103 g/cap.day
Sum of S-fractions = 21889.78 kg/y
S content per TSS (S particulate/TSS) = 0.29729 %
S content per TS (Total S/TS) = 1.9887 %

Total phosphorus = 12.4031 g/m³; 14118.3825 kg/y; 1.934 g/cap.day
PO₄-P = 8.5456 g/m³; 9727.4325 kg/y; 1.3325 g/cap.day
P particulate = 3.8575 g/m³; 4390.95 kg/y; 0.6015 g/cap.day
Sum of P-fractions = 14118.3825 kg/y
P content per TSS (P particulate/TSS) = 0.91469 %
P content per TS (Total P/TS) = 1.2827 %

Total potassium = 26.7998 g/m³; 30505.97 kg/y; 4.1789 g/cap.day
Dissolved potassium = 24.9207 g/m³; 28367.07 kg/y; 3.8859 g/cap.day
Organically bound potassium = 1.879 g/m³; 2138.9 kg/y; 0.293 g/cap.day
K content per TSS (Organically bound K/TSS) = 0.44556 %
K content per TS (Total K/TS) = 2.7715 %
Temperature in water = 12 degC

Effluent wastewater from primary sedimentation

BOD₇ = 248.8752 g/m³; 299808.1996 kg/y; 41.0696 g/cap.day
COD total = 528.6046 g/m³; 636784.837 kg/y; 87.2308 g/cap.day
COD biosol = 256.2418 g/m³; 308682.373 kg/y; 42.2853 g/cap.day
COD insol = 63.5143 g/m³; 76512.7062 kg/y; 10.4812 g/cap.day
COD biopart = 94.5319 g/m³; 113878.0931 kg/y; 15.5997 g/cap.day
COD inpart = 114.3165 g/m³; 137711.6647 kg/y; 18.8646 g/cap.day
Sum of COD-fractions = 636784.837 kg/y

Volatile solids (VS) = 340.6189 g/m³; 410327.4619 kg/y; 56.2092 g/cap.day
Suspended solids (TSS) = 206.5658 g/m³; 248840.0504 kg/y; 34.0877 g/cap.day
Dissolved solids (TS-TSS) = 561.8288 g/m³; 676808.5119 kg/y; 92.7135 g/cap.day
Fixed solids (TS-VS) = 427.7757 g/m³; 515321.1003 kg/y; 70.5919 g/cap.day
Total solids (TS) = 768.3946 g/m³; 925648.5622 kg/y; 126.8012 g/cap.day
H₂O = 1203726903.6171 kg/y; 164.8941 kg/cap.day
Total volume = 1204652.5522 m³/y; 3300.418 m³/day
VS content = 0.034062 %
TSS content = 0.020657 %
TS content = 0.076839 %

Total nitrogen = 67.2717 g/m³; 81039.048 kg/y; 11.1012 g/cap.day
N-NH₃ & N-NH₄ = 54.16 g/m³; 65243.9327 kg/y; 8.9375 g/cap.day
N-NO₃ = 0.85879 g/m³; 1034.5417 kg/y; 0.14172 g/cap.day
N-N₂O = 0 g/m³; 0 kg/y; 0 g/cap.day
N-org,part = 3.6508 g/m³; 4397.9089 kg/y; 0.60245 g/cap.day
N-org,sol = 8.6022 g/m³; 10362.6646 kg/y; 1.4195 g/cap.day
Sum of N-fractions = 81039.048 kg/y
N content per TSS (N-org,part/TSS) = 1.7674 %
N content per TS (Total N/TS) = 8.7548 %

Total sulphur = 18.4506 g/m³; 22226.5231 kg/y; 3.0447 g/cap.day
SO₄-S = 17.0985 g/m³; 20597.739 kg/y; 2.8216 g/cap.day
S particulate = 0.58261 g/m³; 701.8472 kg/y; 0.096143 g/cap.day

The URWARE Wastewater Treatment Plant Models

Sulfide HS-S = 0.76946 g/m³; 926.9368 kg/y; 0.12698 g/cap.day
Sum of S-fractions = 22226.5231 kg/y
S content per TSS (S particulate/TSS) = 0.28205 %
S content per TS (Total S/TS) = 2.4012 %

Total phosphorus = 4.3877 g/m³; 5285.616 kg/y; 0.72406 g/cap.day
PO4-P = 1.9993 g/m³; 2408.5192 kg/y; 0.32993 g/cap.day
P particulate = 2.3883 g/m³; 2877.0968 kg/y; 0.39412 g/cap.day
Sum of P-fractions = 5285.616 kg/y
P content per TSS (P particulate/TSS) = 1.1562 %
P content per TS (Total P/TS) = 0.57102 %

Total potassium = 28.8534 g/m³; 34758.2891 kg/y; 4.7614 g/cap.day
Dissolved potassium = 27.9613 g/m³; 33683.7036 kg/y; 4.6142 g/cap.day
Organically bound potassium = 0.89203 g/m³; 1074.5855 kg/y; 0.1472 g/cap.day
K content per TSS (Organically bound K/TSS) = 0.43184 %
K content per TS (Total K/TS) = 3.755 %
Temperature in water = 12 degC

Sludge output from primary sedimentation incl thickener

BOD7 = 12987.1505 g/m³; 122916.064 kg/y; 16.8378 g/cap.day
COD total = 40193.7231 g/m³; 380410.9487 kg/y; 52.1111 g/cap.day
COD biosol = 256.2418 g/m³; 2425.1846 kg/y; 0.33222 g/cap.day
COD insol = 63.5143 g/m³; 601.1274 kg/y; 0.082346 g/cap.day
COD biopart = 18048.3155 g/m³; 170817.1396 kg/y; 23.3996 g/cap.day
COD inpart = 21825.6515 g/m³; 206567.4971 kg/y; 28.2969 g/cap.day
Sum of COD-fractions = 380410.9487 kg/y

Volatile solids (VS) = 31255.2717 g/m³; 295813.5414 kg/y; 40.5224 g/cap.day
Suspended solids (TSS) = 39438.1712 g/m³; 373260.0756 kg/y; 51.1315 g/cap.day
Dissolved solids (TS-TSS) = 561.8288 g/m³; 5317.3932 kg/y; 0.72841 g/cap.day
Fixed solids (TS-VS) = 8744.7283 g/m³; 82763.9274 kg/y; 11.3375 g/cap.day
Total solids (TS) = 40000 g/m³; 378577.4688 kg/y; 51.8599 g/cap.day
H2O = 9085859.2512 kg/y; 1.2446 kg/cap.day
Total volume = 9464.4367 m³/y; 25.93 m³/day
VS content = 3.1255 %
TSS content = 3.9438 %
TS content = 4 %

Total nitrogen = 760.6369 g/m³; 7198.9998 kg/y; 0.98616 g/cap.day
N-NH3 & N-NH4 = 54.16 g/m³; 512.5935 kg/y; 0.070218 g/cap.day
N-NO3 = 0.85879 g/m³; 8.1279 kg/y; 0.0011134 g/cap.day
N-N2O = 0 g/m³; 0 kg/y; 0 g/cap.day
N-org,part = 697.016 g/m³; 6596.8634 kg/y; 0.90368 g/cap.day
N-org,sol = 8.6022 g/m³; 81.415 kg/y; 0.011153 g/cap.day
Sum of N-fractions = 7198.9998 kg/y
N content per TSS (N-org,part/TSS) = 1.7674 %
N content per TS (Total N/TS) = 1.9016 %

Total sulphur = 129.1023 g/m³; 1221.8809 kg/y; 0.16738 g/cap.day
SO4-S = 17.0985 g/m³; 161.8276 kg/y; 0.022168 g/cap.day
S particulate = 111.2344 g/m³; 1052.7708 kg/y; 0.14422 g/cap.day
Sulfide HS-S = 0.76946 g/m³; 7.2825 kg/y; 0.00099761 g/cap.day
Sum of S-fractions = 1221.8809 kg/y
S content per TSS (S particulate/TSS) = 0.28205 %
S content per TS (Total S/TS) = 0.32276 %

Total phosphorus = 1522.6948 g/m³; 14411.4489 kg/y; 1.9742 g/cap.day

The URWARE Wastewater Treatment Plant Models

P04-P = 1.9993 g/m³; 18.9227 kg/y; 0.0025922 g/cap.day
P particulate = 1520.6955 g/m³; 14392.5262 kg/y; 1.9716 g/cap.day
Sum of P-fractions = 14411.4489 kg/y
P content per TSS (P particulate/TSS) = 3.8559 %
P content per TS (Total P/TS) = 3.8067 %

Total potassium = 198.2703 g/m³; 1876.5166 kg/y; 0.25706 g/cap.day
Dissolved potassium = 27.9613 g/m³; 264.6384 kg/y; 0.036252 g/cap.day
Organically bound potassium = 170.3089 g/m³; 1611.8782 kg/y; 0.22081 g/cap.day
K content per TSS (Organically bound K/TSS) = 0.43184 %
K content per TS (Total K/TS) = 0.49568 %
Temperature in water = 12 degC

Chemicals and energy use in primary sedimentation system

Added chemicals (FeCl₃) = 79204.2847 kg/y; 3.9602 kg/cap.y; 216.998 kg/day; 0.01085 kg/cap.day
Energy consumption (total) = 21985.2304 MJ/y; 6107.0085 kWh/y
Energy consumption (mixing) = 6556.2317 MJ/y; 1821.1755 kWh/y
Energy consumption (sludge scrapers) = 6687.3564 MJ/y; 1857.599 kWh/y
Energy consumption (pumping) = 8741.6423 MJ/y; 2428.234 kWh/y

Status in the AS anoxic reactor

BOD₇ = 1784.5899 g/m³; 13011702.5612 kg/y; 1782.425 g/cap.day
COD total = 7046.1075 g/m³; 51374187.7701 kg/y; 7037.56 g/cap.day
COD biosol = 4.2754 g/m³; 31172.3153 kg/y; 4.2702 g/cap.day
COD insol = 63.5143 g/m³; 463092.1928 kg/y; 63.4373 g/cap.day
COD biopart = 2741.2475 g/m³; 19986831.625 kg/y; 2737.9221 g/cap.day
COD inpart = 4237.0703 g/m³; 30893091.637 kg/y; 4231.9304 g/cap.day
COD slowly biodeg part = 23.4202 g/m³; 170760.1788 kg/y; 23.3918 g/cap.day
COD Heterotrophs = 2577.7711 g/m³; 18794901.7512 kg/y; 2574.6441 g/cap.day
COD Autotrophs = 140.0562 g/m³; 1021169.695 kg/y; 139.8863 g/cap.day
Sum of COD-fractions = 51374187.7701 kg/y

Volatile solids (VS) = 4196.9324 g/m³; 30600440.5207 kg/y; 4191.8412 g/cap.day
Suspended solids (TSS) = 5641.4124 g/m³; 41132353.1634 kg/y; 5634.5689 g/cap.day
Dissolved solids (TS-TSS) = 556.0992 g/m³; 4054599.7938 kg/y; 555.4246 g/cap.day
Fixed solids (TS-VS) = 2000.5793 g/m³; 14586512.4365 kg/y; 1998.1524 g/cap.day
Total solids (TS) = 6197.5117 g/m³; 45186952.9572 kg/y; 6189.9936 g/cap.day
H₂O = 7245957531.3583 kg/y; 992.5969 kg/cap.day
Total volume = 7291144.4843 m³/y; 19975.7383 m³/day
VS content = 0.41969 %
TSS content = 0.56414 %
TS content = 0.61975 %

Total nitrogen = 378.0066 g/m³; 2756100.9275 kg/y; 377.5481 g/cap.day
N-NH₃ & N-NH₄ = 10.0813 g/m³; 73504.2533 kg/y; 10.0691 g/cap.day
N-NO₃ = 3.6046 g/m³; 26281.3556 kg/y; 3.6002 g/cap.day
N-N₂O = 0 g/m³; 0 kg/y; 0 g/cap.day
N-org,part not Xnd = 361.8274 g/m³; 2638136.0743 kg/y; 361.3885 g/cap.day
N-org,sol not Snd = 0.65681 g/m³; 4788.9008 kg/y; 0.65601 g/cap.day
N-org, Snd = 0.51632 g/m³; 3764.5398 kg/y; 0.51569 g/cap.day
N-org Xnd = 1.3202 g/m³; 9625.8037 kg/y; 1.3186 g/cap.day
Sum of N-fractions = 2756100.9275 kg/y

Total sulphur = 42.9519 g/m³; 313168.4882 kg/y; 42.8998 g/cap.day
SO₄-S = 16.7719 g/m³; 122286.0011 kg/y; 16.7515 g/cap.day
S particulate,bio = 13.4229 g/m³; 97868.2524 kg/y; 13.4066 g/cap.day

The URWARE Wastewater Treatment Plant Models

Sulfide HS-S = 0.78619 g/m³; 5732.2198 kg/y; 0.78524 g/cap.day
S particulate,inert = 11.971 g/m³; 87282.015 kg/y; 11.9564 g/cap.day
Sum of S-fractions = 313168.4882 kg/y

Total phosphorus = 105.2372 g/m³; 767299.2926 kg/y; 105.1095 g/cap.day
PO₄-P = 0.47222 g/m³; 3442.9957 kg/y; 0.47164 g/cap.day
P particulate not Xpn = 104.3782 g/m³; 761036.3691 kg/y; 104.2516 g/cap.day
P part Xpn = 0.38676 g/m³; 2819.9278 kg/y; 0.38629 g/cap.day
Sum of P-fractions = 767299.2926 kg/y

Total potassium = 117.2327 g/m³; 854760.2808 kg/y; 117.0904 g/cap.day
Dissolved potassium = 25.5211 g/m³; 186078.0237 kg/y; 25.4901 g/cap.day
Organically bound potassium = 91.7116 g/m³; 668682.2571 kg/y; 91.6003 g/cap.day
Temperature in water = 12 degC

Extra outputs from the AS anoxic reactor

Added carbon source = 0 kg COD/y; 0 kg COD/cap.y; 0 kg COD/day; 0 kg COD/cap.day
Total oxygen into system = 0 kg O₂/y; 0 kg O₂/cap.y; 0 kg O₂/day; 0 kg O₂/cap.day
CO₂ production = 192288.9033 kg CO₂/y; 9.6144 kg CO₂/cap.y; 526.8189 kg CO₂/day; 0.026341 kg CO₂/cap.day
N₂ production = 44374.1615 kg N₂/y; 2.2187 kg N₂/cap.y; 121.573 kg N₂/day; 0.0060787 kg N₂/cap.day
N₂O production = 34.8829 kg N₂O/y; 0.0017441 kg N₂O/cap.y; 0.095569 kg N₂O/day; 4.7785e-06 kg N₂O/cap.day
Energy consumption (total) = 56302.2177 MJ/y; 15639.5049 kWh/y
Energy consumption (mixing) = 56302.2177 MJ/y; 15639.5049 kWh/y
Energy consumption (pumping) = 0 MJ/y; 0 kWh/y
Energy consumption (aeration) = 0 MJ/y; 0 kWh/y

Status in the AS anoxic reactor

BOD₇ = 1770.4668 g/m³; 3227182.2477 kg/y; 442.0798 g/cap.day
COD total = 7028.292 g/m³; 12811073.1077 kg/y; 1754.9415 g/cap.day
COD biosol= 1.5199 g/m³; 2770.4451 kg/y; 0.37951 g/cap.day
COD insol = 63.5143 g/m³; 115773.0481 kg/y; 15.8593 g/cap.day
COD biopart = 2722.2751 g/m³; 4962125.3206 kg/y; 679.7432 g/cap.day
COD inpart = 4240.9826 g/m³; 7730404.2939 kg/y; 1058.9595 g/cap.day
COD slowly biodeg part = 11.1396 g/m³; 20305.0694 kg/y; 2.7815 g/cap.day
COD Heterotrophs = 2569.9494 g/m³; 4684468.1638 kg/y; 641.708 g/cap.day
COD Autotrophs = 141.1861 g/m³; 257352.0874 kg/y; 35.2537 g/cap.day
Sum of COD-fractions = 12811073.1077 kg/y

Volatile solids (VS) = 4183.6902 g/m³; 7625972.4909 kg/y; 1044.6538 g/cap.day
Suspended solids (TSS) = 5629.1137 g/m³; 10260670.2486 kg/y; 1405.5713 g/cap.day
Dissolved solids (TS-TSS) = 568.398 g/m³; 1036067.9908 kg/y; 141.9271 g/cap.day
Fixed solids (TS-VS) = 2013.8214 g/m³; 3670765.7484 kg/y; 502.8446 g/cap.day
Total solids (TS) = 6197.5117 g/m³; 11296738.2394 kg/y; 1547.4984 g/cap.day
H₂O = 1811489382.8491 kg/y; 248.1492 kg/cap.day
Total volume = 1822786.1211 m³/y; 4993.9346 m³/day
VS content = 0.41837 %
TSS content = 0.56291 %
TS content = 0.61975 %

Total nitrogen = 377.5905 g/m³; 688266.6881 kg/y; 94.2831 g/cap.day
N-NH₃ & N-NH₄ = 2.6268 g/m³; 4788.0691 kg/y; 0.6559 g/cap.day
N-NO₃ = 11.4423 g/m³; 20856.7775 kg/y; 2.8571 g/cap.day
N-N₂O = 0 g/m³; 0 kg/y; 0 g/cap.day
N-org,part not Xnd = 361.4866 g/m³; 658912.794 kg/y; 90.262 g/cap.day

The URWARE Wastewater Treatment Plant Models

N-org, sol not Snd = 0.65681 g/m³; 1197.2252 kg/y; 0.164 g/cap.day
N-org, Snd = 0.51649 g/m³; 941.4577 kg/y; 0.12897 g/cap.day
N-org Xnd = 0.86152 g/m³; 1570.3647 kg/y; 0.21512 g/cap.day
Sum of N-fractions = 688266.6881 kg/y

Total sulphur = 42.9519 g/m³; 78292.1472 kg/y; 10.725 g/cap.day
SO₄-S = 17.5068 g/m³; 31911.0657 kg/y; 4.3714 g/cap.day
S particulate, bio = 13.4088 g/m³; 24441.4535 kg/y; 3.3481 g/cap.day
Sulfide HS-S = 0.057132 g/m³; 104.1388 kg/y; 0.014266 g/cap.day
S particulate, inert = 11.9792 g/m³; 21835.4892 kg/y; 2.9912 g/cap.day
Sum of S-fractions = 78292.1472 kg/y

Total phosphorus = 105.2372 g/m³; 191824.8967 kg/y; 26.2774 g/cap.day
PO₄-P = 0.73785 g/m³; 1344.9508 kg/y; 0.18424 g/cap.day
P particulate not Xpn = 104.2835 g/m³; 190086.4783 kg/y; 26.0392 g/cap.day
P part Xpn = 0.21586 g/m³; 393.4676 kg/y; 0.0539 g/cap.day
Sum of P-fractions = 191824.8967 kg/y

Total potassium = 117.2327 g/m³; 213690.1486 kg/y; 29.2726 g/cap.day
Dissolved potassium = 25.6549 g/m³; 46763.4608 kg/y; 6.406 g/cap.day
Organically bound potassium = 91.5778 g/m³; 166926.6878 kg/y; 22.8667 g/cap.day
Temperature in water = 12 degC

Extra outputs from the AS aerobic reactor

Biological oxygen consumption = 408320.496 kg COD/y; 20.416 kg COD/cap.y; 1118.6863 kg COD/day; 0.055934 kg COD/cap.day
Total oxygen into system = 636639.3391 kg O₂/y; 31.832 kg O₂/cap.y; 1744.2174 kg O₂/day; 0.087211 kg O₂/cap.day
CO₂ production = 197194.8989 kg CO₂/y; 9.8597 kg CO₂/cap.y; 540.26 kg CO₂/day; 0.027013 kg CO₂/cap.day
N₂ production = 3016.8467 kg N₂/y; 0.15084 kg N₂/cap.y; 8.2653 kg N₂/day; 0.00041327 kg N₂/cap.day
N₂O production = 28.3709 kg N₂O/y; 0.0014185 kg N₂O/cap.y; 0.077728 kg N₂O/day; 3.8864e-06 kg N₂O/cap.day
Energy consumption (total) = 1539672.6126 MJ/y; 427686.8368 kWh/y
Energy consumption (mixing) = 0 MJ/y; 0 kWh/y
Energy consumption (pumping) = 393721.8022 MJ/y; 109367.1673 kWh/y
Energy consumption (aeration) = 1145950.8104 MJ/y; 318319.6696 kWh/y

Effluent wastewater from activated sludge sedimentation

BOD₇ = 7.1032 g/m³; 8519.4755 kg/y; 1.1671 g/cap.day
COD total = 95.4073 g/m³; 114430.8269 kg/y; 15.6755 g/cap.day
COD biosol = 1.5199 g/m³; 1822.9529 kg/y; 0.24972 g/cap.day
COD insol = 63.5143 g/m³; 76178.6657 kg/y; 10.4354 g/cap.day
COD biopart = 9.408 g/m³; 11283.9324 kg/y; 1.5457 g/cap.day
COD inpart = 20.965 g/m³; 25145.2759 kg/y; 3.4446 g/cap.day
Sum of COD-fractions = 114430.8269 kg/y

Volatile solids (VS) = 52.1585 g/m³; 62558.5912 kg/y; 8.5697 g/cap.day
Suspended solids (TSS) = 24.5536 g/m³; 29449.4562 kg/y; 4.0342 g/cap.day
Dissolved solids (TS-TSS) = 561.8288 g/m³; 673853.6943 kg/y; 92.3087 g/cap.day
Fixed solids (TS-VS) = 534.2239 g/m³; 640744.5592 kg/y; 87.7732 g/cap.day
Total solids (TS) = 586.3824 g/m³; 703303.1505 kg/y; 96.3429 g/cap.day
H₂O = 1198689964.5173 kg/y; 164.2041 kg/cap.day
Total volume = 1199393.2677 m³/y; 3286.009 m³/day
VS content = 0.0052159 %
TSS content = 0.0024554 %
TS content = 0.058638 %

The URWARE Wastewater Treatment Plant Models

Total nitrogen = 16.8229 g/m³; 20177.2348 kg/y; 2.764 g/cap.day
N-NH₃ & N-NH₄ = 2.6268 g/m³; 3150.5495 kg/y; 0.43158 g/cap.day
N-NO₃ = 11.4423 g/m³; 13723.7596 kg/y; 1.88 g/cap.day
N-N₂O = 0 g/m³; 0 kg/y; 0 g/cap.day
N-org,part = 1.5805 g/m³; 1895.6724 kg/y; 0.25968 g/cap.day
N-org,sol = 1.1733 g/m³; 1407.2533 kg/y; 0.19277 g/cap.day
Sum of N-fractions = 20177.2348 kg/y
N content per TSS (N-org,part/TSS) = 6.437 %
N content per TS (Total N/TS) = 2.8689 %

Total sulphur = 17.6746 g/m³; 21198.8254 kg/y; 2.9039 g/cap.day
SO₄-S = 17.5068 g/m³; 20997.4812 kg/y; 2.8764 g/cap.day
S particulate = 0.11074 g/m³; 132.8208 kg/y; 0.018195 g/cap.day
Sulfide HS-S = 0.057132 g/m³; 68.5233 kg/y; 0.0093868 g/cap.day
Sum of S-fractions = 21198.8254 kg/y
S content per TSS (S particulate/TSS) = 0.45101 %
S content per TS (Total S/TS) = 3.0142 %

Total phosphorus = 1.1937 g/m³; 1431.6798 kg/y; 0.19612 g/cap.day
PO₄-P = 0.73785 g/m³; 884.9776 kg/y; 0.12123 g/cap.day
P particulate = 0.45582 g/m³; 546.7022 kg/y; 0.074891 g/cap.day
Sum of P-fractions = 1431.6798 kg/y
P content per TSS (P particulate/TSS) = 1.8564 %
P content per TS (Total P/TS) = 0.20357 %

Total potassium = 26.0544 g/m³; 31249.4585 kg/y; 4.2807 g/cap.day
Dissolved potassium = 25.6549 g/m³; 30770.3572 kg/y; 4.2151 g/cap.day
Organically bound potassium = 0.39945 g/m³; 479.1013 kg/y; 0.06563 g/cap.day
K content per TSS (Organically bound K/TSS) = 1.6269 %
K content per TS (Total K/TS) = 4.4432 %
Temperature in water = 12 degC

Sludge removal from activated sludge sedimentation

BOD₇ = 4088.5296 g/m³; 64588.4634 kg/y; 8.8477 g/cap.day
COD total = 20367.0001 g/m³; 321747.2703 kg/y; 44.075 g/cap.day
COD biosol = 1.5199 g/m³; 24.0105 kg/y; 0.0032891 g/cap.day
COD insol = 63.5143 g/m³; 1003.3664 kg/y; 0.13745 g/cap.day
COD biopart = 6288.5256 g/m³; 99342.8562 kg/y; 13.6086 g/cap.day
COD inpart = 14013.4402 g/m³; 221377.0371 kg/y; 30.3256 g/cap.day
Sum of COD-fractions = 321747.2703 kg/y

Volatile solids (VS) = 11838.533 g/m³; 187018.9844 kg/y; 25.619 g/cap.day
Suspended solids (TSS) = 16412.1561 g/m³; 259270.7023 kg/y; 35.5165 g/cap.day
Dissolved solids (TS-TSS) = 561.8288 g/m³; 8875.4793 kg/y; 1.2158 g/cap.day
Fixed solids (TS-VS) = 5135.4519 g/m³; 81127.1972 kg/y; 11.1133 g/cap.day
Total solids (TS) = 16973.9849 g/m³; 268146.1816 kg/y; 36.7324 g/cap.day
H₂O = 15529333.5344 kg/y; 2.1273 kg/cap.day
Total volume = 15797.4797 m³/y; 43.2808 m³/day
VS content = 1.1839 %
TSS content = 1.6412 %
TS content = 1.6974 %

Total nitrogen = 1071.6989 g/m³; 16930.1421 kg/y; 2.3192 g/cap.day
N-NH₃ & N-NH₄ = 2.6268 g/m³; 41.4966 kg/y; 0.0056845 g/cap.day
N-NO₃ = 11.4423 g/m³; 180.7587 kg/y; 0.024761 g/cap.day
N-N₂O = 0 g/m³; 0 kg/y; 0 g/cap.day
N-org,part = 1056.4566 g/m³; 16689.3515 kg/y; 2.2862 g/cap.day
N-org,sol = 1.1733 g/m³; 18.5353 kg/y; 0.0025391 g/cap.day

The URWARE Wastewater Treatment Plant Models

Sum of N-fractions = 16930.1421 kg/y
N content per TSS (N-org,part/TSS) = 6.437 %
N content per TS (Total N/TS) = 6.3138 %

Total sulphur = 91.5848 g/m³; 1446.8093 kg/y; 0.19819 g/cap.day
SO₄-S = 17.5068 g/m³; 276.5626 kg/y; 0.037885 g/cap.day
S particulate = 74.0209 g/m³; 1169.3442 kg/y; 0.16018 g/cap.day
Sulfide HS-S = 0.057132 g/m³; 0.90254 kg/y; 0.00012364 g/cap.day
Sum of S-fractions = 1446.8093 kg/y
S content per TSS (S particulate/TSS) = 0.45101 %
S content per TS (Total S/TS) = 0.53956 %

Total phosphorus = 305.4145 g/m³; 4824.7794 kg/y; 0.66093 g/cap.day
PO₄-P = 0.73785 g/m³; 11.6562 kg/y; 0.0015967 g/cap.day
P particulate = 304.6766 g/m³; 4813.1231 kg/y; 0.65933 g/cap.day
Sum of P-fractions = 4824.7794 kg/y
P content per TSS (P particulate/TSS) = 1.8564 %
P content per TS (Total P/TS) = 1.7993 %

Total potassium = 292.6577 g/m³; 4623.2534 kg/y; 0.63332 g/cap.day
Dissolved potassium = 25.6549 g/m³; 405.2833 kg/y; 0.055518 g/cap.day
Organically bound potassium = 267.0027 g/m³; 4217.97 kg/y; 0.5778 g/cap.day
K content per TSS (Organically bound K/TSS) = 1.6269 %
K content per TS (Total K/TS) = 1.7242 %
Temperature in water = 12 degC

Energy use in the activated sludge settler

Energy consumption (total) = 122053.7587 MJ/y; 33903.8219 kWh/y
Energy consumption (mixing) = 0 MJ/y; 0 kWh/y
Energy consumption (sludge scrapers) = 9843.0451 MJ/y; 2734.1792 kWh/y
Energy consumption (pumping) = 112210.7136 MJ/y; 31169.6427 kWh/y

Effluent wastewater from the AS thickener

BOD₇ = 1226.4892 g/m³; 12924.9823 kg/y; 1.7705 g/cap.day
COD total = 6151.843 g/m³; 64829.3224 kg/y; 8.8807 g/cap.day
COD biosol = 1.5199 g/m³; 16.017 kg/y; 0.0021941 g/cap.day
COD insol = 63.5143 g/m³; 669.3265 kg/y; 0.091689 g/cap.day
COD biopart = 1885.3865 g/m³; 19868.5712 kg/y; 2.7217 g/cap.day
COD inpart = 4201.4222 g/m³; 44275.4078 kg/y; 6.0651 g/cap.day
Sum of COD-fractions = 64829.3224 kg/y

Volatile solids (VS) = 3573.5108 g/m³; 37658.3544 kg/y; 5.1587 g/cap.day
Suspended solids (TSS) = 4920.5903 g/m³; 51854.1407 kg/y; 7.1033 g/cap.day
Dissolved solids (TS-TSS) = 561.8288 g/m³; 5920.6617 kg/y; 0.81105 g/cap.day
Fixed solids (TS-VS) = 1908.9083 g/m³; 20116.448 kg/y; 2.7557 g/cap.day
Total solids (TS) = 5482.4191 g/m³; 57774.8024 kg/y; 7.9144 g/cap.day
H₂O = 10480420.402 kg/y; 1.4357 kg/cap.day
Total volume = 10538.1952 m³/y; 28.8718 m³/day
VS content = 0.35735 %
TSS content = 0.49206 %
TS content = 0.54824 %

Total nitrogen = 331.9826 g/m³; 3498.4971 kg/y; 0.47925 g/cap.day
N-NH₃ & N-NH₄ = 2.6268 g/m³; 27.6816 kg/y; 0.003792 g/cap.day
N-NO₃ = 11.4423 g/m³; 120.5807 kg/y; 0.016518 g/cap.day
N-N₂O = 0 g/m³; 0 kg/y; 0 g/cap.day
N-org,part = 316.7402 g/m³; 3337.8703 kg/y; 0.45724 g/cap.day
N-org,sol = 1.1733 g/m³; 12.3645 kg/y; 0.0016938 g/cap.day

The URWARE Wastewater Treatment Plant Models

Sum of N-fractions = 3498.4971 kg/y
N content per TSS (N-org,part/TSS) = 6.437 %
N content per TS (Total N/TS) = 6.0554 %

Total sulphur = 39.7564 g/m³; 418.9605 kg/y; 0.057392 g/cap.day
SO₄-S = 17.5068 g/m³; 184.4896 kg/y; 0.025273 g/cap.day
S particulate = 22.1925 g/m³; 233.8688 kg/y; 0.032037 g/cap.day
Sulfide HS-S = 0.057132 g/m³; 0.60206 kg/y; 8.2475e-05 g/cap.day
Sum of S-fractions = 418.9605 kg/y
S content per TSS (S particulate/TSS) = 0.45101 %
S content per TS (Total S/TS) = 0.72516 %

Total phosphorus = 92.0841 g/m³; 970.4003 kg/y; 0.13293 g/cap.day
PO₄-P = 0.73785 g/m³; 7.7757 kg/y; 0.0010652 g/cap.day
P particulate = 91.3463 g/m³; 962.6246 kg/y; 0.13187 g/cap.day
Sum of P-fractions = 970.4003 kg/y
P content per TSS (P particulate/TSS) = 1.8564 %
P content per TS (Total P/TS) = 1.6796 %

Total potassium = 105.706 g/m³; 1113.9507 kg/y; 0.1526 g/cap.day
Dissolved potassium = 25.6549 g/m³; 270.3567 kg/y; 0.037035 g/cap.day
Organically bound potassium = 80.0511 g/m³; 843.594 kg/y; 0.11556 g/cap.day
K content per TSS (Organically bound K/TSS) = 1.6269 %
K content per TS (Total K/TS) = 1.9281 %
Temperature in water = 12 degC

Sludge from the AS thickener

BOD₇ = 9823.2908 g/m³; 51663.481 kg/y; 7.0772 g/cap.day
COD total = 48850.3615 g/m³; 256917.9482 kg/y; 35.1942 g/cap.day
COD biosol = 1.5199 g/m³; 7.9936 kg/y; 0.001095 g/cap.day
COD insol = 63.5143 g/m³; 334.04 kg/y; 0.045759 g/cap.day
COD biopart = 15111.2352 g/m³; 79474.285 kg/y; 10.8869 g/cap.day
COD inpart = 33674.092 g/m³; 177101.6297 kg/y; 24.2605 g/cap.day
Sum of COD-fractions = 256917.9482 kg/y

Volatile solids (VS) = 28399.4202 g/m³; 149360.6301 kg/y; 20.4604 g/cap.day
Suspended solids (TSS) = 39438.1712 g/m³; 207416.5619 kg/y; 28.4132 g/cap.day
Dissolved solids (TS-TSS) = 561.8288 g/m³; 2954.8176 kg/y; 0.40477 g/cap.day
Fixed solids (TS-VS) = 11600.5798 g/m³; 61010.7493 kg/y; 8.3576 g/cap.day
Total solids (TS) = 40000 g/m³; 210371.3794 kg/y; 28.818 g/cap.day
H₂O = 5048913.1062 kg/y; 0.69163 kg/cap.day
Total volume = 5259.2845 m³/y; 14.409 m³/day
VS content = 2.8399 %
TSS content = 3.9438 %
TS content = 4 %

Total nitrogen = 2553.8921 g/m³; 13431.645 kg/y; 1.84 g/cap.day
N-NH₃ & N-NH₄ = 2.6268 g/m³; 13.815 kg/y; 0.0018925 g/cap.day
N-NO₃ = 11.4423 g/m³; 60.1781 kg/y; 0.0082436 g/cap.day
N-N₂O = 0 g/m³; 0 kg/y; 0 g/cap.day
N-org,part = 2538.6497 g/m³; 13351.4812 kg/y; 1.829 g/cap.day
N-org,sol = 1.1733 g/m³; 6.1707 kg/y; 0.00084531 g/cap.day
Sum of N-fractions = 13431.645 kg/y
N content per TSS (N-org,part/TSS) = 6.437 %
N content per TS (Total N/TS) = 6.3847 %

Total sulphur = 195.4351 g/m³; 1027.8488 kg/y; 0.1408 g/cap.day
SO₄-S = 17.5068 g/m³; 92.073 kg/y; 0.012613 g/cap.day

The URWARE Wastewater Treatment Plant Models

S particulate = 177.8712 g/m³; 935.4754 kg/y; 0.12815 g/cap.day
Sulfide HS-S = 0.057132 g/m³; 0.30047 kg/y; 4.1161e-05 g/cap.day
Sum of S-fractions = 1027.8488 kg/y
S content per TSS (S particulate/TSS) = 0.45101 %
S content per TS (Total S/TS) = 0.48859 %

Total phosphorus = 732.8714 g/m³; 3854.3791 kg/y; 0.528 g/cap.day
PO₄-P = 0.73785 g/m³; 3.8806 kg/y; 0.00053159 g/cap.day
P particulate = 732.1335 g/m³; 3850.4985 kg/y; 0.52747 g/cap.day
Sum of P-fractions = 3854.3791 kg/y
P content per TSS (P particulate/TSS) = 1.8564 %
P content per TS (Total P/TS) = 1.8322 %

Total potassium = 667.2586 g/m³; 3509.3026 kg/y; 0.48073 g/cap.day
Dissolved potassium = 25.6549 g/m³; 134.9266 kg/y; 0.018483 g/cap.day
Organically bound potassium = 641.6036 g/m³; 3374.376 kg/y; 0.46224 g/cap.day
K content per TSS (Organically bound K/TSS) = 1.6269 %
K content per TS (Total K/TS) = 1.6681 %
Temperature in water = 12 degC

Energy use in the AS thickener

Energy consumption (total) = 2928.8527 MJ/y; 813.5702 kWh/y
Energy consumption (mixing) = 0 MJ/y; 0 kWh/y
Energy consumption (sludge scrapers) = 85.3064 MJ/y; 23.6962 kWh/y
Energy consumption (pumping) = 2843.5463 MJ/y; 789.874 kWh/y

Effluent wastewater from the sand filter, i.e plant effluent

BOD₇ = 1.4132 g/m³; 1610.3253 kg/y; 0.22059 g/cap.day
COD total = 67.1448 g/m³; 76512.2657 kg/y; 10.4811 g/cap.day
COD biosol = 1.5199 g/m³; 1731.8953 kg/y; 0.23725 g/cap.day
COD insol = 63.5127 g/m³; 72373.4963 kg/y; 9.9142 g/cap.day
COD biopart = 0.65425 g/m³; 745.5282 kg/y; 0.10213 g/cap.day
COD inpart = 1.4579 g/m³; 1661.3458 kg/y; 0.22758 g/cap.day
Sum of COD-fractions = 76512.2657 kg/y

Volatile solids (VS) = 35.7262 g/m³; 40710.3709 kg/y; 5.5768 g/cap.day
Suspended solids (TSS) = 2 g/m³; 2279.0229 kg/y; 0.31219 g/cap.day
Dissolved solids (TS-TSS) = 562.6222 g/m³; 641114.4639 kg/y; 87.8239 g/cap.day
Fixed solids (TS-VS) = 528.8961 g/m³; 602683.1159 kg/y; 82.5593 g/cap.day
Total solids (TS) = 564.6222 g/m³; 643393.4867 kg/y; 88.1361 g/cap.day
H₂O = 1138868036.521 kg/y; 156.0093 kg/cap.day
Total volume = 1139511.43 m³/y; 3121.9491 m³/day
VS content = 0.0035726 %
TSS content = 0.0002 %
TS content = 0.056462 %

Total nitrogen = 15.3519 g/m³; 17493.6344 kg/y; 2.3964 g/cap.day
N-NH₃ & N-NH₄ = 2.6267 g/m³; 2993.1777 kg/y; 0.41002 g/cap.day
N-NO₃ = 11.442 g/m³; 13038.2497 kg/y; 1.7861 g/cap.day
N-N₂O = 0 g/m³; 0 kg/y; 0 g/cap.day
N-org,part = 0.10991 g/m³; 125.2469 kg/y; 0.017157 g/cap.day
N-org,sol = 1.1733 g/m³; 1336.9602 kg/y; 0.18315 g/cap.day
Sum of N-fractions = 17493.6344 kg/y
N content per TSS (N-org,part/TSS) = 5.4956 %
N content per TS (Total N/TS) = 2.719 %

Total sulphur = 17.5711 g/m³; 20022.5207 kg/y; 2.7428 g/cap.day
SO₄-S = 17.5063 g/m³; 19948.6447 kg/y; 2.7327 g/cap.day

The URWARE Wastewater Treatment Plant Models

S particulate = 0.0077011 g/m³; 8.7755 kg/y; 0.0012021 g/cap.day
Sulfide HS-S = 0.05713 g/m³; 65.1006 kg/y; 0.0089179 g/cap.day
Sum of S-fractions = 20022.5207 kg/y
S content per TSS (S particulate/TSS) = 0.38505 %
S content per TS (Total S/TS) = 3.112 %

Total phosphorus = 0.1317 g/m³; 150.0688 kg/y; 0.020557 g/cap.day
PO₄-P = 0.099997 g/m³; 113.9483 kg/y; 0.015609 g/cap.day
P particulate = 0.031698 g/m³; 36.1206 kg/y; 0.004948 g/cap.day
Sum of P-fractions = 150.0688 kg/y
P content per TSS (P particulate/TSS) = 1.5849 %
P content per TS (Total P/TS) = 0.023325 %

Total potassium = 25.6821 g/m³; 29265.0139 kg/y; 4.0089 g/cap.day
Dissolved potassium = 25.6543 g/m³; 29233.3597 kg/y; 4.0046 g/cap.day
Organically bound potassium = 0.027779 g/m³; 31.6542 kg/y; 0.0043362 g/cap.day
K content per TSS (Organically bound K/TSS) = 1.3889 %
K content per TS (Total K/TS) = 4.5485 %
Temperature in water = 12 degC

Sludge output (backwash) from the sand filter

BOD₇ = 115.3218 g/m³; 6909.1501 kg/y; 0.94646 g/cap.day
COD total = 632.9053 g/m³; 37918.5614 kg/y; 5.1943 g/cap.day
COD biosol = 1.5199 g/m³; 91.0576 kg/y; 0.012474 g/cap.day
COD insol = 63.5127 g/m³; 3805.1693 kg/y; 0.52126 g/cap.day
COD biopart = 175.8983 g/m³; 10538.4042 kg/y; 1.4436 g/cap.day
COD inpart = 391.9744 g/m³; 23483.9303 kg/y; 3.217 g/cap.day
Sum of COD-fractions = 37918.5614 kg/y

Volatile solids (VS) = 364.6724 g/m³; 21848.2205 kg/y; 2.9929 g/cap.day
Suspended solids (TSS) = 537.7078 g/m³; 32215.0961 kg/y; 4.413 g/cap.day
Dissolved solids (TS-TSS) = 562.6222 g/m³; 33707.7689 kg/y; 4.6175 g/cap.day
Fixed solids (TS-VS) = 735.6576 g/m³; 44074.6445 kg/y; 6.0376 g/cap.day
Total solids (TS) = 1100.33 g/m³; 65922.865 kg/y; 9.0305 g/cap.day
H₂O = 59845980.8006 kg/y; 8.1981 kg/cap.day
Total volume = 59911.9037 m³/y; 164.1422 m³/day
VS content = 0.036467 %
TSS content = 0.053771 %
TS content = 0.11003 %

Total nitrogen = 44.7924 g/m³; 2683.6004 kg/y; 0.36762 g/cap.day
N-NH₃ & N-NH₄ = 2.6267 g/m³; 157.3718 kg/y; 0.021558 g/cap.day
N-NO₃ = 11.442 g/m³; 685.5099 kg/y; 0.093905 g/cap.day
N-N₂O = 0 g/m³; 0 kg/y; 0 g/cap.day
N-org,part = 29.5505 g/m³; 1770.4256 kg/y; 0.24252 g/cap.day
N-org,sol = 1.1733 g/m³; 70.2931 kg/y; 0.0096292 g/cap.day
Sum of N-fractions = 2683.6004 kg/y
N content per TSS (N-org,part/TSS) = 5.4956 %
N content per TS (Total N/TS) = 4.0708 %

Total sulphur = 19.6339 g/m³; 1176.3047 kg/y; 0.16114 g/cap.day
SO₄-S = 17.5063 g/m³; 1048.8366 kg/y; 0.14368 g/cap.day
S particulate = 2.0705 g/m³; 124.0454 kg/y; 0.016993 g/cap.day
Sulfide HS-S = 0.05713 g/m³; 3.4228 kg/y; 0.00046887 g/cap.day
Sum of S-fractions = 1176.3047 kg/y
S content per TSS (S particulate/TSS) = 0.38505 %
S content per TS (Total S/TS) = 1.7844 %

Total phosphorus = 21.3916 g/m³; 1281.611 kg/y; 0.17556 g/cap.day

The URWARE Wastewater Treatment Plant Models

PO4-P = 0.099997 g/m³; 5.991 kg/y; 0.00082069 g/cap.day
P particulate = 21.2916 g/m³; 1275.6199 kg/y; 0.17474 g/cap.day
Sum of P-fractions = 1281.611 kg/y
P content per TSS (P particulate/TSS) = 3.9597 %
P content per TS (Total P/TS) = 1.9441 %

Total potassium = 33.1227 g/m³; 1984.4446 kg/y; 0.27184 g/cap.day
Dissolved potassium = 25.6543 g/m³; 1536.9975 kg/y; 0.21055 g/cap.day
Organically bound potassium = 7.4684 g/m³; 447.4471 kg/y; 0.061294 g/cap.day
K content per TSS (Organically bound K/TSS) = 1.3889 %
K content per TS (Total K/TS) = 3.0103 %
Temperature in water = 12 degC

Chemicals and energy use in the sand filter

Added chemicals (FeCl₃) = 6013.2011 kg/y; 0.30066 kg/cap.y; 16.4745 kg/day; 0.00082373 kg/cap.day
Energy consumption (total) = 49656.126 MJ/y; 13793.3683 kWh/y
Energy consumption (mixing) = 6476.886 MJ/y; 1799.135 kWh/y
Energy consumption (sludge scrapers) = 0 MJ/y; 0 kWh/y
Energy consumption (pumping) = 0 MJ/y; 0 kWh/y
Energy consumption (filter) = 43179.24 MJ/y; 11994.2333 kWh/y

Influent sludge to the anaerobic digester

BOD₇ = 11857.026 g/m³; 174579.5451 kg/y; 23.915 g/cap.day
COD total = 43285.8574 g/m³; 637328.8969 kg/y; 87.3053 g/cap.day
COD biosol = 165.2557 g/m³; 2433.1781 kg/y; 0.33331 g/cap.day
COD insol = 63.5143 g/m³; 935.1674 kg/y; 0.12811 g/cap.day
COD biopart = 16999.1961 g/m³; 250291.4246 kg/y; 34.2865 g/cap.day
COD inpart = 26057.8913 g/m³; 383669.1268 kg/y; 52.5574 g/cap.day
Sum of COD-fractions = 637328.8969 kg/y

Volatile solids (VS) = 30235.1671 g/m³; 445174.1715 kg/y; 60.9828 g/cap.day
Suspended solids (TSS) = 39438.1712 g/m³; 580676.6374 kg/y; 79.5447 g/cap.day
Dissolved solids (TS-TSS) = 561.8288 g/m³; 8272.2108 kg/y; 1.1332 g/cap.day
Fixed solids (TS-VS) = 9764.8329 g/m³; 143774.6767 kg/y; 19.6952 g/cap.day
Total solids (TS) = 40000 g/m³; 588948.8482 kg/y; 80.6779 g/cap.day
H₂O = 14134772.3574 kg/y; 1.9363 kg/cap.day
Total volume = 14723.7212 m³/y; 40.339 m³/day
VS content = 3.0235 %
TSS content = 3.9438 %
TS content = 4 %

Total nitrogen = 1401.1842 g/m³; 20630.6449 kg/y; 2.8261 g/cap.day
N-NH₃ & N-NH₄ = 35.7524 g/m³; 526.4085 kg/y; 0.072111 g/cap.day
N-NO₃ = 4.6392 g/m³; 68.306 kg/y; 0.009357 g/cap.day
N-N₂O = 0 g/m³; 0 kg/y; 0 g/cap.day
N-org,part = 1354.8439 g/m³; 19948.3446 kg/y; 2.7326 g/cap.day
N-org,sol = 5.9486 g/m³; 87.5857 kg/y; 0.011998 g/cap.day
Sum of N-fractions = 20630.6449 kg/y
N content per TSS (N-org,part/TSS) = 3.4354 %
N content per TS (Total N/TS) = 3.503 %

Total sulphur = 152.7963 g/m³; 2249.7298 kg/y; 0.30818 g/cap.day
SO₄-S = 17.2443 g/m³; 253.9006 kg/y; 0.034781 g/cap.day
S particulate = 135.0369 g/m³; 1988.2462 kg/y; 0.27236 g/cap.day
Sulfide HS-S = 0.51502 g/m³; 7.583 kg/y; 0.0010388 g/cap.day
Sum of S-fractions = 2249.7298 kg/y
S content per TSS (S particulate/TSS) = 0.3424 %

The URWARE Wastewater Treatment Plant Models

S content per TS (Total S/TS) = 0.38199 %

Total phosphorus = 1240.5714 g/m³; 18265.828 kg/y; 2.5022 g/cap.day

PO₄-P = 1.5487 g/m³; 22.8033 kg/y; 0.0031237 g/cap.day

P particulate = 1239.0227 g/m³; 18243.0247 kg/y; 2.499 g/cap.day

Sum of P-fractions = 18265.828 kg/y

P content per TSS (P particulate/TSS) = 3.1417 %

P content per TS (Total P/TS) = 3.1014 %

Total potassium = 365.792 g/m³; 5385.8192 kg/y; 0.73778 g/cap.day

Dissolved potassium = 27.1375 g/m³; 399.565 kg/y; 0.054735 g/cap.day

Organically bound potassium = 338.6545 g/m³; 4986.2542 kg/y; 0.68305 g/cap.day

K content per TSS (Organically bound K/TSS) = 0.8587 %

K content per TS (Total K/TS) = 0.91448 %

Temperature in water = 12 degC

Effluent sludge from the anaerobic digester

BOD₇ = 2231.2665 g/m³; 32537.8852 kg/y; 4.4572 g/cap.day

COD total = 33239.4508 g/m³; 484720.864 kg/y; 66.4001 g/cap.day

COD biosol = 0 g/m³; 0 kg/y; 0 g/cap.day

COD insol = 922.308 g/m³; 13449.7386 kg/y; 1.8424 g/cap.day

COD biopart = 3432.7177 g/m³; 50058.2849 kg/y; 6.8573 g/cap.day

COD inpart = 28884.4251 g/m³; 421212.8405 kg/y; 57.7004 g/cap.day

Sum of COD-fractions = 484720.864 kg/y

Volatile solids (VS) = 15263.7797 g/m³; 222587.0858 kg/y; 30.4914 g/cap.day

Suspended solids (TSS) = 29600.9109 g/m³; 431661.137 kg/y; 59.1317 g/cap.day

Dissolved solids (TS-TSS) = 1115.3117 g/m³; 16264.2528 kg/y; 2.228 g/cap.day

Fixed solids (TS-VS) = 15452.4429 g/m³; 225338.304 kg/y; 30.8683 g/cap.day

Total solids (TS) = 30716.2226 g/m³; 447925.3898 kg/y; 61.3596 g/cap.day

H₂O = 14134772.3574 kg/y; 1.9363 kg/cap.day

Total volume = 14582.6977 m³/y; 39.9526 m³/day

VS content = 1.5264 %

TSS content = 2.9601 %

TS content = 3.0716 %

Total nitrogen = 1410.0504 g/m³; 20562.3389 kg/y; 2.8168 g/cap.day

N-NH₃ & N-NH₄ = 597.5428 g/m³; 8713.7856 kg/y; 1.1937 g/cap.day

N-NO₃ = 0 g/m³; 0 kg/y; 0 g/cap.day

N-N₂O = 0 g/m³; 0 kg/y; 0 g/cap.day

N-org,part = 806.5015 g/m³; 11760.9675 kg/y; 1.6111 g/cap.day

N-org,sol = 6.0061 g/m³; 87.5857 kg/y; 0.011998 g/cap.day

Sum of N-fractions = 20562.3389 kg/y

N content per TSS (N-org,part/TSS) = 2.7246 %

N content per TS (Total N/TS) = 4.5906 %

Total sulphur = 152.7961 g/m³; 2228.1794 kg/y; 0.30523 g/cap.day

SO₄-S = 0 g/m³; 0 kg/y; 0 g/cap.day

S particulate = 139.4959 g/m³; 2034.2263 kg/y; 0.27866 g/cap.day

Sulfide HS-S = 13.3002 g/m³; 193.9531 kg/y; 0.026569 g/cap.day

Sum of S-fractions = 2228.1794 kg/y

S content per TSS (S particulate/TSS) = 0.47126 %

S content per TS (Total S/TS) = 0.49744 %

Total phosphorus = 1252.5685 g/m³; 18265.828 kg/y; 2.5022 g/cap.day

PO₄-P = 206.0049 g/m³; 3004.1071 kg/y; 0.41152 g/cap.day

P particulate = 1046.5636 g/m³; 15261.7209 kg/y; 2.0906 g/cap.day

Sum of P-fractions = 18265.828 kg/y

P content per TSS (P particulate/TSS) = 3.5356 %

The URWARE Wastewater Treatment Plant Models

P content per TS (Total P/TS) = 4.0779 %

Total potassium = 369.3294 g/m³; 5385.8192 kg/y; 0.73778 g/cap.day
Dissolved potassium = 300.6751 g/m³; 4384.6535 kg/y; 0.60064 g/cap.day
Organically bound potassium = 68.6544 g/m³; 1001.1657 kg/y; 0.13715 g/cap.day
K content per TSS (Organically bound K/TSS) = 0.23193 %
K content per TS (Total K/TS) = 1.2024 %
Temperature in water = 12 degC

Extra outputs from the digester

Energy consumption (mixing) = 53005.3963 MJ/y; 14723.7212 kWh/y
Energy consumption (pumping) = 2624.8856 MJ/y; 729.1349 kWh/y
Energy consumption (heat pumps) = 158034.6076 MJ/y; 43898.5021 kWh/y
Energy consumption (heating) = 1422311.4685 MJ/y; 395086.519 kWh/y
Heat energy recovered (heat pumps) = 711155.7342 MJ/y; 197543.2595 kWh/y
Energy content of produced methane = 1908134.5391 MJ/y; 530037.372 kWh/y
Total electrical energy consumption = 213664.8895 MJ/y; 59351.3582 kWh/y
Total heat consumption = 711155.7342 MJ/y; 197543.2595 kWh/y
Total energy production = 983313.9153 MJ/y; 273142.7543 kWh/y
CO₂ gas production = 51123.691 kg CO₂/y = 1161.9021 kmole/y
CH₄ gas production = 38152.0082 kg CH₄/y = 2384.5005 kmole/y = 53210.6112 Nm³/y = 152608.0329 kg COD/y
H₂S gas production = 21.5503 kg H₂S-S/y = 0.67345 kmole/y
N₂ gas production = 68.306 kg N₂/y = 2.4395 kmole/y
Molar relationship in gas: CH₄ = 67.1782%; CO₂ = 32.7341%; H₂S = 0.018973%; N₂ = 0.068728%

Effluent wastewater from digested sludge dewatering

BOD₇ = 209.6998 g/m³; 3253.7885 kg/y; 0.44572 g/cap.day
COD total = 3858.6994 g/m³; 59873.1763 kg/y; 8.2018 g/cap.day
COD biosol = 0 g/m³; 0 kg/y; 0 g/cap.day
COD insol = 799.5172 g/m³; 12405.6403 kg/y; 1.6994 g/cap.day
COD biopart = 322.615 g/m³; 5005.8285 kg/y; 0.68573 g/cap.day
COD inpart = 2736.5671 g/m³; 42461.7075 kg/y; 5.8167 g/cap.day
Sum of COD-fractions = 59873.1763 kg/y

Volatile solids (VS) = 2088.2907 g/m³; 32402.7828 kg/y; 4.4387 g/cap.day
Suspended solids (TSS) = 2796.3985 g/m³; 43390.0765 kg/y; 5.9438 g/cap.day
Dissolved solids (TS-TSS) = 966.8255 g/m³; 15001.6648 kg/y; 2.055 g/cap.day
Fixed solids (TS-VS) = 1674.9333 g/m³; 25988.9585 kg/y; 3.5601 g/cap.day
Total solids (TS) = 3763.224 g/m³; 58391.7413 kg/y; 7.9989 g/cap.day
H₂O = 15458022.0689 kg/y; 2.1175 kg/cap.day
Total volume = 15516.4138 m³/y; 42.5107 m³/day
VS content = 0.20883 %
TSS content = 0.27964 %
TS content = 0.37632 %

Total nitrogen = 598.9928 g/m³; 9294.2209 kg/y; 1.2732 g/cap.day
N-NH₃ & N-NH₄ = 517.9894 g/m³; 8037.3377 kg/y; 1.101 g/cap.day
N-NO₃ = 0 g/m³; 0 kg/y; 0 g/cap.day
N-N₂O = 0 g/m³; 0 kg/y; 0 g/cap.day
N-org,part = 75.7969 g/m³; 1176.0968 kg/y; 0.16111 g/cap.day
N-org,sol = 5.2065 g/m³; 80.7865 kg/y; 0.011067 g/cap.day
Sum of N-fractions = 9294.2209 kg/y
N content per TSS (N-org,part/TSS) = 2.7105 %
N content per TS (Total N/TS) = 15.917 %

Total sulphur = 24.6397 g/m³; 382.3192 kg/y; 0.052372 g/cap.day

The URWARE Wastewater Treatment Plant Models

SO₄-S = 0 g/m³; 0 kg/y; 0 g/cap.day
S particulate = 13.1102 g/m³; 203.4226 kg/y; 0.027866 g/cap.day
Sulfide HS-S = 11.5295 g/m³; 178.8966 kg/y; 0.024506 g/cap.day
Sum of S-fractions = 382.3192 kg/y
S content per TSS (S particulate/TSS) = 0.46882 %
S content per TS (Total S/TS) = 0.65475 %

Total phosphorus = 276.9372 g/m³; 4297.0715 kg/y; 0.58864 g/cap.day
PO₄-P = 178.5786 g/m³; 2770.8994 kg/y; 0.37958 g/cap.day
P particulate = 98.3586 g/m³; 1526.1721 kg/y; 0.20906 g/cap.day
Sum of P-fractions = 4297.0715 kg/y
P content per TSS (P particulate/TSS) = 3.5173 %
P content per TS (Total P/TS) = 7.359 %

Total potassium = 267.0972 g/m³; 4144.391 kg/y; 0.56772 g/cap.day
Dissolved potassium = 260.6449 g/m³; 4044.2745 kg/y; 0.55401 g/cap.day
Organically bound potassium = 6.4523 g/m³; 100.1166 kg/y; 0.013715 g/cap.day
K content per TSS (Organically bound K/TSS) = 0.23074 %
K content per TS (Total K/TS) = 7.0976 %
Temperature in water = 12 degC

Sludge removal from digested sludge dewatering, i.e. output sludge

BOD₇ = 22424.2682 g/m³; 29284.0967 kg/y; 4.0115 g/cap.day
COD total = 327933.4867 g/m³; 428251.9208 kg/y; 58.6646 g/cap.day
COD biosol = 0 g/m³; 0 kg/y; 0 g/cap.day
COD insol = 799.5172 g/m³; 1044.0983 kg/y; 0.14303 g/cap.day
COD biopart = 34498.8741 g/m³; 45052.4564 kg/y; 6.1716 g/cap.day
COD inpart = 292635.0953 g/m³; 382155.3661 kg/y; 52.3501 g/cap.day
Sum of COD-fractions = 428251.9208 kg/y

Volatile solids (VS) = 147005.4365 g/m³; 191976.0046 kg/y; 26.2981 g/cap.day
Suspended solids (TSS) = 299033.1745 g/m³; 390510.6876 kg/y; 53.4946 g/cap.day
Dissolved solids (TS-TSS) = 966.8255 g/m³; 1262.588 kg/y; 0.17296 g/cap.day
Fixed solids (TS-VS) = 152994.5635 g/m³; 199797.271 kg/y; 27.3695 g/cap.day
Total solids (TS) = 300000 g/m³; 391773.2756 kg/y; 53.6676 g/cap.day
H₂O = 914137.643 kg/y; 0.12522 kg/cap.day
Total volume = 1305.9109 m³/y; 3.5778 m³/day
VS content = 14.7005 %
TSS content = 29.9033 %
TS content = 30 %

Total nitrogen = 8628.5502 g/m³; 11268.118 kg/y; 1.5436 g/cap.day
N-NH₃ & N-NH₄ = 517.9894 g/m³; 676.448 kg/y; 0.092664 g/cap.day
N-NO₃ = 0 g/m³; 0 kg/y; 0 g/cap.day
N-N₂O = 0 g/m³; 0 kg/y; 0 g/cap.day
N-org,part = 8105.3543 g/m³; 10584.8707 kg/y; 1.45 g/cap.day
N-org,sol = 5.2065 g/m³; 6.7992 kg/y; 0.0009314 g/cap.day
Sum of N-fractions = 11268.118 kg/y
N content per TSS (N-org,part/TSS) = 2.7105 %
N content per TS (Total N/TS) = 2.8762 %

Total sulphur = 1413.4656 g/m³; 1845.8602 kg/y; 0.25286 g/cap.day
SO₄-S = 0 g/m³; 0 kg/y; 0 g/cap.day
S particulate = 1401.9361 g/m³; 1830.8037 kg/y; 0.2508 g/cap.day
Sulfide HS-S = 11.5295 g/m³; 15.0565 kg/y; 0.0020625 g/cap.day
Sum of S-fractions = 1845.8602 kg/y
S content per TSS (S particulate/TSS) = 0.46882 %
S content per TS (Total S/TS) = 0.47116 %

The URWARE Wastewater Treatment Plant Models

Total phosphorus = 10696.5616 g/m³; 13968.7565 kg/y; 1.9135 g/cap.day
PO₄-P = 178.5786 g/m³; 233.2077 kg/y; 0.031946 g/cap.day
P particulate = 10517.983 g/m³; 13735.5488 kg/y; 1.8816 g/cap.day
Sum of P-fractions = 13968.7565 kg/y
P content per TSS (P particulate/TSS) = 3.5173 %
P content per TS (Total P/TS) = 3.5655 %

Total potassium = 950.6224 g/m³; 1241.4282 kg/y; 0.17006 g/cap.day
Dissolved potassium = 260.6449 g/m³; 340.379 kg/y; 0.046627 g/cap.day
Organically bound potassium = 689.9775 g/m³; 901.0491 kg/y; 0.12343 g/cap.day
K content per TSS (Organically bound K/TSS) = 0.23074 %
K content per TS (Total K/TS) = 0.31687 %
Temperature in water = 12 degC

Chemicals and energy use in digested sludge dewatering unit

Added polymers = 2239.6269 kg/y; 0.11198 kg/cap.y; 6.136 kg/day; 0.0003068 kg/cap.day
Energy consumption (total) = 87476.0884 MJ/y; 24298.9135 kWh/y

9

Energy considerations

The energy requirements and energy efficiency vary significantly from one WWTP to another. There may be many reasons for this and the user of URWARE is advised to investigate the energy consumption carefully if a specific plant is to be modelled. In particular the anaerobic digester can behave very differently with regard to energy depending on the type of added equipment used (hygenisation, heat exchangers, heat pumps, gas engines, etc.). The default values for energy usage given in this document are chosen to represent a large and energy efficient plant but should still only be considered as example values. As all energy related parameters are set specifically for each module it is easy for the user modify these for his/her specific needs. Some more information related to energy issues in WWTPs can be found in, for example, Kennedy (1997), Kjellén and Andersson (2002).

The most apparent factor that seems to affect the energy efficiency of a plant is the size. Large plants normally consume considerably less energy per cubic metre of treated wastewater than small plants. For this reason a special energy adjustment function has been implemented in the software, which allows the user to define a function relating the size of the plant to an energy factor. By using this function the user does not have to modify all energy related parameters when comparing plants of different sizes but can instead define this function in a suitable way. The function is enabled or disabled via a global parameter in `spInit.m`. The user simply defines a few data points in the file `spEnergyAdjust.m` and the software interpolates between these points (linear, cubic-spline or whatever the user requests). On the x-axis we have the number of PE connected to the plant and on the y-axis is the energy adjustment factor. Note that the first x-value should always be 0 and the last x-value an unreasonably large value (associated with an y-value = 1). When this function is activated all energy calculations within URWARE WWTP models are multiplied by this before given as an output to the user (as discussed in the previous chapters, note special comments for the digester model). The code for the function is given in Appendix S and also as pseudo-code below.

```

global spTotalFlowIn; %input flow to the plant for a simulation l/y
spPE = 200*365; %personal equivalent l/y, PE set to 200 l/d
% define points to create the curve. The curve can be defined according to
% any user needs
xpoints = [ 0 10000 50000 250000 1e10 ]; %xaxis points based on PE
ypoints = [ 2.5 2 1.5 1 1 ]; %the associated energy adjustment factor
y = interp1(xpoints, ypoints, spTotalFlowIn/spPE, 'linear');

```

The values given in the example above are the default values for the energy adjustment function. They mean that for a plant of more than 250000 PE no adjustment is made (energy factor = 1) and for the smallest plant a factor of 2.5 is used. One PE is here set to equal a flow of 200 l/d but that can be adjusted by the user. The shape of the curve is given in Figure 9.1. In this case linear interpolation is used.

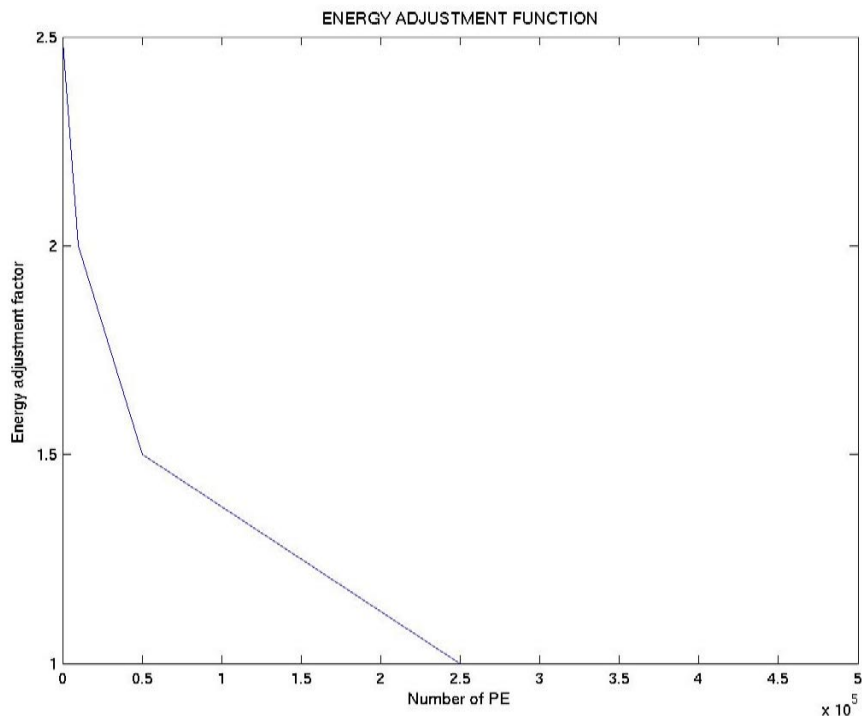

Figure 9.1
The principle of the energy adjustment function.

Two major energy consumptions are not directly included in the models. The first one is related to influent pumping. Normally the influent wastewater needs to be lifted from the sewer system into the first part of the WWTP, which requires a significant amount of energy. Lifting the influent wastewater 5 to 20 meters is not uncommon. For example, the influent wastewater at Sweden's largest WWTP (Rya WWTP in Göteborg) is lifted about 20 metres before entering the plant. The energy required to lift 1 m³ of water one meter is probably in the range of 5 to 10 Wh (= 18000 to 36000 J). The second energy consumer not included in the model is the plant itself, in terms of energy required for offices, laboratories, etc., which are part of the plant (e.g. for heating, light, office equipment).

Something like 10% of the plants total energy consumption may be used for these purposes. Consequently, if the total energy consumption for a WWTP is needed then the above consumptions need to be added.

For most of the models defined within URWARE the actual physical dimensions are not defined. It is simply assumed that the processes are well designed and are able to meet the requests of the user. Only within the activated sludge modules the actual volumes of the reactors are defined (in terms of hydraulic retention time and sludge age). This is a consequence of the overall purpose of the software. Therefore the energy values suggested in this document are almost always related to flow rates rather than reactor volumes. However, for some of the processes it is possible to assume some reasonable dimensions and thereby recalculate the energy values, which may enhance the possibility of comparing the suggested energy parameters with other information sources.

For simplicity the energy required for all pumping of wastewater and sludge within the plant is by default set to 50 Wh/m^3 ($= 180 \text{ kJ/m}^3$) for all processes except for internal recirculation within the activated sludge system, where it is set to 20 Wh/m^3 ($= 72 \text{ kJ/m}^3$). In reality, the required pumping energy may be quite different for different processes depending on the flow rates needed to be pumped, to where the flow is pumped (i.e. how much the wastewater needs to be lifted), etc. If the user has detailed information then explicit pumping parameter values should be set for the different processes. Every module has its own set of parameters so this is easily accomplished by modifying the spInit file.

The energy required for sludge scrapers in settlers and thickeners are by default set to 1.5 Wh/m^3 ($= 5400 \text{ J/m}^3$) of influent flow rate. If, for example, we assume a primary clarifier with a depth of 4 metres and a hydraulic loading rate of 1 m/h, 2 m/h or 3 m/h (i.e. a hydraulic retention time of 4, 2 or 1.33 hours) this would imply a power consumption for sludge scrapers of 0.375, 0.75 and 1.12 W/m^3 of settler volume, respectively. Similar transformations can easily be made for the secondary clarifier, final clarifier and thickener.

As discussed in Section 6.2 the energy calculations for mixing in the activated sludge system is different than what is used in other modules. In the AS system we actually have knowledge about the dimensions of the reactors and it is therefore much better to base the energy calculations on reactor volume and power consumption per m^3 of reactor volume. If the energy consumption was based on flow (i.e. J/m^3) this would lead to the strange effect that the mixing energy would be identical for a plant with 5% or 55% anoxic volume (assuming the same influent wastewater and same total hydraulic retention time). The proposed value for power consumption for mixing is set to 2.5 W/m^3 . We can see from Case 6.4 that for a system with a hydraulic retention time of 0.6 days (45% anoxic and 55% aerobic volume) and a sludge age of 12 days the energy required for mixing in the anoxic zone is 95.786 GJ/y . Using the data above this is equivalent to a energy consumption of 58000 J/m^3 of nominal influent wastewater flow to the AS system. However, changing the anoxic volume

fraction to 25% would lead to a lower energy consumption as it is volume related rather than flow related. In Case 6.2, the energy needed for mixing was much higher ($355 \text{ GJ/y} = 216 \text{ kJ/m}^3$ of nominal influent flow) although the influent flow rate was the same. Obviously, since we simulated the anoxic reactor as a stand-alone model in Case 6.2 we had to set the hydraulic retention time to a very high value (24 h), which is immediately reflected in the energy consumption figures.

For the digester the default energy requirement is set to 3.6 MJ/m^3 ($= 1 \text{ kWh/m}^3$) of the sludge flow for mixing purposes. If we assume a digester with a retention time of 10, 15 or 20 days this would imply a power consumption for mixing of 4.17, 2.78 or 2.08 W/m^3 of digester reactor volume, respectively. For the digester the explicit volume is not defined by URWARE and it is simply assumed that the retention time is sufficient. Therefore we cannot base the energy consumption on power per cubic metre as for the AS mixing energy. However, values normally found in the literature indicate that values of 2.5 to 5 W/m^3 reactor volume are usually encountered in reality, which are in good agreement with the values produced by URWARE when reasonable retention times are assumed for the digester.

We could continue to make this type of transformations for basically all energy parameter values presented in this document. However, the principle shown above is enough for the interested reader to recalculate the other figures into a m^3 reactor volume equivalent by simply making some reasonable assumptions. Such calculations may be especially useful if the user has access to detailed physical layout data and design data of the plant he/she intends to simulate. The lack of physical design data (volumes, cross-sectional areas, depths, etc.) in URWARE can certainly be regarded as a drawback, but as always, this fact has to be considered bearing the intended purpose of the software in mind. If a user would have needed to define all the physical data for a plant to simulate, it would require much more effort and considerable process knowledge. Moreover, the complexity of most models would have to be increased in order to make use of such specific data.

10 Sewer system transformations

The sewer system is not just a pipe structure transporting water to a wastewater treatment plant but a biological reactor by itself. Although the biological effects are seldom modelled they should not be ignored.

The hydraulic impacts and hydrodynamics of the sewer can be described using many available models, e.g. MOUSE. Here the impact of the entire urban drainage system can be included, such as infiltration from ground water, storm water addition during rainfall, the flow dynamics within the sewer system based on collection basins and pumping stations, size of pipes, elevation difference within the system, etc. However, as URWARE is only focussing on yearly averages these effects are ignored. Only an energy consumption within the sewer system is included to allow for a rough estimate of energy required for pumping stations within the sewers (proportional to the flow of wastewater). This part existed already in ORWARE.

From a biological point of view the sewer system can be regarded as a huge biofilm reactor. Particulate material accumulates in the sewer and on the sewer wall during dry weather and is released during rain events due to the hydraulic impact. The sewer biofilm plays a central role in (Huisman *et al.*, 2003):

- respiration of oxygen and easily degradable substrate;
- production of hydrogen sulphide;
- production of easily biodegradable substrate that is greatly needed for nutrient removal in WWTPs;
- production of bacteria and storage of degradable material that can be released through a combined sewer overflow and cause an oxygen surge after a rain event;
- seeding filamentous bacteria, sulphate reducing and oxidising bacteria into the treatment plant.

A main factor for the biological transformations is related to the type of sewer system being investigated in terms of available oxygen in it. A *flat sewer* indicates a long residence time and little surface reaeration. Consequently, the wastewater will become anaerobic and large quantities of easily

biodegradable substrate can be produced. However, some COD degradation will occur, either directly or via the sulphur cycle. In a *steep sewer* the high surface reaeration results in mainly oxic conditions producing a significant reduction of COD and the wastewater contains limited amounts of readily biodegradable substrate as it reaches the plant. The situation of the sewer system in Norway is a good general representation of this latter situation. After a rain event a significant part of the biomass may be washed out and the remaining biofilm may go into a fast-growing phase and extract more COD from the wastewater than usual and release practically no readily biodegradable substrate. This can explain why the performance of nutrient removal processes is often reduced after rain events.

If the wastewater in the sewer contains nitrate then denitrification is likely to occur in both situations. As the biofilm is normally quite thick the inner layers of the film may be anoxic even though aerobic conditions exist on the surface. Consequently, the huge wetted surface area in a sewer system has a potential as a denitrification reactor although the pumping costs and infrastructural investments are major limiting factors for implementing such a scheme on a large scale.

Proposals have been made in the literature of including fully dynamic biofilm and activated sludge models to describe the biological transformations taking place in the sewer system. However, for the purpose of URWARE this is not relevant. Instead we make the following assumptions to simplify the model:

- on an average over a year the same amount of biomass formed in the sewer will also be detached and exit the sewer (although some of it will have decayed into inert material), i.e. no accumulation of solids within the sewer;
- biomass growth is associated with an inert fraction of particulate COD as a result of biomass decay (not explicitly modelled);
- hydrolysis of COD will occur in both flat and steep sewer systems;
- hydrolysis of COD will be associated with hydrolysis of particulate N, P, S and K;
- hydrolysis of COD will affect the total suspended solids but not the volatile solids and the total solids;
- a fraction of the soluble N formed via hydrolysis (50%) will be subject to ammonification and end up as ammonia nitrogen;
- inclusion of N, P, S and K in formed biomass is taken into account;
- transformations related to the sulphur cycle are not modelled explicitly although 50% of the particulate sulphur released through hydrolysis is assumed to be available as sulphate and 50% is assumed to form sulphide;
- oxygen reaeration and consumption is ignored;
- possible nutrient limitation conditions for growth are ignored;
- denitrification (normally almost no nitrate in the sewer wastewater) and nitrification are ignored.

The model is implemented in the file `spSewerBioModel.m`. The user defines the behaviour of the sewer system model via two main parameters (defined in `spSewerBioInit.m`):

- **spSewerBioHyd**: value between 0 and 100%. Defines the fraction of the particulate biodegradable COD into the sewer system that is hydrolysed;
- **spSewerBioGrowth**: value between 0 and 100%. Defines the fraction of the soluble biodegradable COD (including the amount formed via hydrolysis) that is consumed by microorganisms within the sewer system.

Based on these two parameters the reactions take place in accordance with the assumptions made above. The parameters are gathered into a vector (**spSewerBioPAR**) and included as an argument when calling the actual sewer model. All remaining parameters necessary for the model to work properly are defined in `spSewerBioInit.m` and gathered into a vector (**spSewerBioDEF**) also included as an argument. In principle, the values of these latter parameters are taken from already existing models used to describe the wastewater treatment plant. A user should be careful in terms of giving high values to the two main parameters. If both parameters are set to 100% then almost all biodegradable COD will be consumed within the sewer (apart from some particulate material, which equals the biodegradable part of the biomass formed after decay). If no explicit knowledge of the modelled sewer system exists then values not exceeding 25% are recommended for both parameters.

To demonstrate the behaviour of the model, a few simulation cases are presented below. The content of the wastewater coming into the sewer system is first defined and then three cases are shown. Case 10.1 represents a sewer system with only hydrolysis and no biomass growth. Case 10.2 represent a system with no hydrolysis and only growth (not realistic but given to allow the user to examine the behaviour of the growth part of the model without influence from the hydrolysis part). In Case 10.3, a combination of hydrolysis and biological growth is assumed. In all cases, the parameters defined in the **spSewerBioDEF** vector are identical and it is only the two parameters in **spSewerBioPAR** that are modified.

Case 10.1: Sewer model with hydrolysis processes (no biomass growth)

Model parameters: **spSewerBioHyd** = 0.25 (25%)
 spSewerBioGrowth = 0.0 (0%)

Parameters defined in `spSewerBioDEF`:

Nratio_sewer = 2 (ratio of N in biodegradable:inert particulate sewer sludge)
Pratio_sewer = 2 (ratio of P in biodegradable:inert particulate sewer sludge)
Sratio_sewer = 2 (ratio of S in biodegradable:inert particulate sewer sludge)

Kratio_sewer = 10 (ratio of K in biodegradable:inert particulate sewer sludge)
solNtoNH4 = 0.5 (fraction of formed soluble N that is ammonified)
solStoSO4 = 0.5 (fraction of formed soluble S that is sulphate)
Y_observed = 0.5 (observed (net) yield for biomass growth)
f_P_observed = 0.21 (true inert fraction of biomass decay (no regeneration))
f_decay = 0.5 (fraction of formed biomass decaying in the sewer system)
i_XB_sewer = 0.086 (mass N/mass COD in biomass)
i_XBP_sewer = 0.02 (mass P/mass COD in biomass)
i_Xsulf_sewer = 0.0021 (mass S/mass COD in biomass)
i_XBK_sewer = 0.02 (mass K/mass COD in biomass)
spCODtoVS_sewer(1,1) = 1/1.42 (COD biodegradable to VS conversion factor)
spCODtoVS_sewer(2,1) = 1/1.9 (COD inert to VS conversion factor)

Wastewater entering the sewer system

BOD7 = 351.1889 g/m³; 412561.325 kg/y; 56.5153 g/cap.day
 COD total = 782.8577 g/m³; 919666.848 kg/y; 125.9818 g/cap.day
 COD biosol = 188.3791 g/m³; 221299.5 kg/y; 30.315 g/cap.day
 COD insol = 51.8431 g/m³; 60903.024 kg/y; 8.3429 g/cap.day
 COD biopart = 305.483 g/m³; 358868 kg/y; 49.16 g/cap.day
 COD inpart = 237.1525 g/m³; 278596.324 kg/y; 38.1639 g/cap.day
 Sum of COD-fractions = 919666.848 kg/y

Volatile solids (VS) = 556.2591 g/m³; 653468.8002 kg/y; 89.5163 g/cap.day
 Suspended solids (TSS) = 409.6797 g/m³; 481273.743 kg/y; 65.9279 g/cap.day
 Dissolved solids (TS-TSS) = 527.2868 g/m³; 619433.397 kg/y; 84.8539 g/cap.day
 Fixed solids (TS-VS) = 380.7074 g/m³; 447238.3398 kg/y; 61.2655 g/cap.day
 Total solids (TS) = 936.9665 g/m³; 1100707.14 kg/y; 150.7818 g/cap.day
 H2O = 1173655442.86 kg/y; 160.7747 kg/cap.day
 Total volume = 1174756.15 m³/y; 3218.51 m³/day
 VS content = 0.055626 %
 TSS content = 0.040968 %
 TS content = 0.093697 %

Total nitrogen = 85.9138 g/m³; 100927.7998 kg/y; 13.8257 g/cap.day
 N-NH3 & N-NH4 = 67.7051 g/m³; 79536.9469 kg/y; 10.8955 g/cap.day
 N-NO3 = 0.11674 g/m³; 137.1374 kg/y; 0.018786 g/cap.day
 N-N2O = 0 g/m³; 0 kg/y; 0 g/cap.day
 N-org,part = 9.3302 g/m³; 10960.7155 kg/y; 1.5015 g/cap.day
 N-org,sol = 8.7618 g/m³; 10293 kg/y; 1.41 g/cap.day
 Sum of N-fractions = 100927.7998 kg/y
 N content per TSS (N-org,part/TSS) = 2.2774 %
 N content per TS (Total N/TS) = 9.1694 %

Total sulphur = 18.6484 g/m³; 21907.3 kg/y; 3.001 g/cap.day
 SO4-S = 16.7935 g/m³; 19728.25 kg/y; 2.7025 g/cap.day
 S particulate = 1.2148 g/m³; 1427.15 kg/y; 0.1955 g/cap.day
 Sulfide HS-S = 0.64005 g/m³; 751.9 kg/y; 0.103 g/cap.day
 Sum of S-fractions = 21907.3 kg/y
 S content per TSS (S particulate/TSS) = 0.29654 %
 S content per TS (Total S/TS) = 1.9903 %

Total phosphorus = 11.956 g/m³; 14045.3945 kg/y; 1.924 g/cap.day
 PO4-P = 7.0345 g/m³; 8263.7945 kg/y; 1.132 g/cap.day
 P particulate = 4.9215 g/m³; 5781.6 kg/y; 0.792 g/cap.day
 Sum of P-fractions = 14045.3945 kg/y
 P content per TSS (P particulate/TSS) = 1.2013 %

The URWARE Wastewater Treatment Plant Models

P content per TS (Total P/TS) = 1.276 %

Total potassium = 25.9679 g/m³; 30505.97 kg/y; 4.1789 g/cap.day
Dissolved potassium = 24.1472 g/m³; 28367.07 kg/y; 3.8859 g/cap.day
Organically bound potassium = 1.8207 g/m³; 2138.9 kg/y; 0.293 g/cap.day
K content per TSS (Organically bound K/TSS) = 0.44442 %
K content per TS (Total K/TS) = 2.7715 %

Wastewater exiting the sewer system

BOD₇ = 351.1889 g/m³; 412561.325 kg/y; 56.5153 g/cap.day
COD total = 782.8577 g/m³; 919666.848 kg/y; 125.9818 g/cap.day
COD biosol = 264.7498 g/m³; 311016.5 kg/y; 42.605 g/cap.day
COD insol = 51.8431 g/m³; 60903.024 kg/y; 8.3429 g/cap.day
COD biopart = 229.1122 g/m³; 269151 kg/y; 36.87 g/cap.day
COD inpart = 237.1525 g/m³; 278596.324 kg/y; 38.1639 g/cap.day
Sum of COD-fractions = 919666.848 kg/y

Volatile solids (VS) = 556.2591 g/m³; 653468.8002 kg/y; 89.5163 g/cap.day
Suspended solids (TSS) = 352.0212 g/m³; 413539.0718 kg/y; 56.6492 g/cap.day
Dissolved solids (TS-TSS) = 584.9453 g/m³; 687168.0682 kg/y; 94.1326 g/cap.day
Fixed solids (TS-VS) = 380.7074 g/m³; 447238.3398 kg/y; 61.2655 g/cap.day
Total solids (TS) = 936.9665 g/m³; 1100707.14 kg/y; 150.7818 g/cap.day
H₂O = 1173655442.86 kg/y; 160.7747 kg/cap.day
Total volume = 1174756.15 m³/y; 3218.51 m³/day
VS content = 0.055626 %
TSS content = 0.035202 %
TS content = 0.093697 %

Total nitrogen = 85.9138 g/m³; 100927.7998 kg/y; 13.8257 g/cap.day
N-NH₃ & N-NH₄ = 68.5452 g/m³; 80523.9294 kg/y; 11.0307 g/cap.day
N-NO₃ = 0.11674 g/m³; 137.1374 kg/y; 0.018786 g/cap.day
N-N₂O = 0 g/m³; 0 kg/y; 0 g/cap.day
N-org,part = 7.6499 g/m³; 8986.7506 kg/y; 1.2311 g/cap.day
N-org,sol = 9.602 g/m³; 11279.9824 kg/y; 1.5452 g/cap.day
Sum of N-fractions = 100927.7998 kg/y
N content per TSS (N-org,part/TSS) = 2.1731 %
N content per TS (Total N/TS) = 9.1694 %

Total sulphur = 18.6484 g/m³; 21907.3 kg/y; 3.001 g/cap.day
SO₄-S = 16.9029 g/m³; 19856.761 kg/y; 2.7201 g/cap.day
S particulate = 0.99606 g/m³; 1170.1281 kg/y; 0.16029 g/cap.day
Sulfide HS-S = 0.74944 g/m³; 880.411 kg/y; 0.1206 g/cap.day
Sum of S-fractions = 21907.3 kg/y
S content per TSS (S particulate/TSS) = 0.28295 %
S content per TS (Total S/TS) = 1.9903 %

Total phosphorus = 11.956 g/m³; 14045.3945 kg/y; 1.924 g/cap.day
PO₄-P = 7.9208 g/m³; 9305.0291 kg/y; 1.2747 g/cap.day
P particulate = 4.0352 g/m³; 4740.3655 kg/y; 0.64937 g/cap.day
Sum of P-fractions = 14045.3945 kg/y
P content per TSS (P particulate/TSS) = 1.1463 %
P content per TS (Total P/TS) = 1.276 %

Total potassium = 25.9679 g/m³; 30505.97 kg/y; 4.1789 g/cap.day
Dissolved potassium = 24.5696 g/m³; 28863.2737 kg/y; 3.9539 g/cap.day
Organically bound potassium = 1.3983 g/m³; 1642.6963 kg/y; 0.22503 g/cap.day
K content per TSS (Organically bound K/TSS) = 0.39723 %
K content per TS (Total K/TS) = 2.7715 %

Case 10.2: Sewer model with biomass growth processes (no hydrolysis)

The wastewater entering the sewer system is identical to Case 10.1. Parameter values for the **spSewerBioDEF** vector are also identical (and not repeated here).

Model parameters: **spSewerBioHyd** = 0.0 (0%)
 spSewerBioGrowth = 0.25 (25%)

Wastewater exiting the sewer system

BOD7 = 326.0846 g/m³; 383054.8845 kg/y; 52.4733 g/cap.day
 COD total = 750.0385 g/m³; 881077.7477 kg/y; 120.6956 g/cap.day
 COD biosol= 141.2899 g/m³; 165974.625 kg/y; 22.7363 g/cap.day
 COD insol = 51.8452 g/m³; 60903.024 kg/y; 8.3429 g/cap.day
 COD biopart = 317.2691 g/m³; 372699.2188 kg/y; 51.0547 g/cap.day
 COD inpart = 239.6344 g/m³; 281500.8799 kg/y; 38.5618 g/cap.day
 Sum of COD-fractions = 881077.7477 kg/y

Volatile solids (VS) = 530.0493 g/m³; 622654.1696 kg/y; 85.2951 g/cap.day
 Suspended solids (TSS) = 420.4518 g/m³; 493908.9425 kg/y; 67.6588 g/cap.day
 Dissolved solids (TS-TSS) = 477.235 g/m³; 560612.6703 kg/y; 76.7963 g/cap.day
 Fixed solids (TS-VS) = 367.6375 g/m³; 431867.4432 kg/y; 59.1599 g/cap.day
 Total solids (TS) = 897.6868 g/m³; 1054521.6128 kg/y; 144.455 g/cap.day
 H2O = 1173655442.86 kg/y; 160.7747 kg/cap.day
 Total volume = 1174709.9645 m³/y; 3218.3835 m³/day
 VS content = 0.053005 %
 TSS content = 0.042045 %
 TS content = 0.089769 %

Total nitrogen = 85.9172 g/m³; 100927.7998 kg/y; 13.8257 g/cap.day
 N-NH₃ & N-NH₄ = 65.6826 g/m³; 77157.9773 kg/y; 10.5696 g/cap.day
 N-NO₃ = 0.11674 g/m³; 137.1374 kg/y; 0.018786 g/cap.day
 N-N₂O = 0 g/m³; 0 kg/y; 0 g/cap.day
 N-org,part = 11.3557 g/m³; 13339.6851 kg/y; 1.8274 g/cap.day
 N-org,sol = 8.7622 g/m³; 10293 kg/y; 1.41 g/cap.day
 Sum of N-fractions = 100927.7998 kg/y
 N content per TSS (N-org,part/TSS) = 2.7008 %
 N content per TS (Total N/TS) = 9.571 %

Total sulphur = 18.6491 g/m³; 21907.3 kg/y; 3.001 g/cap.day
 SO₄-S = 16.7447 g/m³; 19670.1589 kg/y; 2.6945 g/cap.day
 S particulate = 1.2643 g/m³; 1485.2411 kg/y; 0.20346 g/cap.day
 Sulfide HS-S = 0.64007 g/m³; 751.9 kg/y; 0.103 g/cap.day
 Sum of S-fractions = 21907.3 kg/y
 S content per TSS (S particulate/TSS) = 0.30071 %
 S content per TS (Total S/TS) = 2.0775 %

Total phosphorus = 11.9565 g/m³; 14045.3945 kg/y; 1.924 g/cap.day
 PO₄-P = 6.5638 g/m³; 7710.5458 kg/y; 1.0562 g/cap.day
 P particulate = 5.3927 g/m³; 6334.8488 kg/y; 0.86779 g/cap.day
 Sum of P-fractions = 14045.3945 kg/y
 P content per TSS (P particulate/TSS) = 1.2826 %
 P content per TS (Total P/TS) = 1.3319 %

Total potassium = 25.9689 g/m³; 30505.97 kg/y; 4.1789 g/cap.day
 Dissolved potassium = 23.6772 g/m³; 27813.8213 kg/y; 3.8101 g/cap.day
 Organically bound potassium = 2.2918 g/m³; 2692.1488 kg/y; 0.36879 g/cap.day
 K content per TSS (Organically bound K/TSS) = 0.54507 %
 K content per TS (Total K/TS) = 2.8929 %

Case 10.3: Sewer model with hydrolysis and biomass growth processes

The wastewater entering the sewer system is identical to Case 10.1. Parameter values for the **spSewerBioDEF** vector are also identical (and not repeated here).

Model parameters: **spSewerBioHyd** = 0.25 (25%)
 spSewerBioGrowth = 0.25 (25%)

Wastewater exiting the sewer system

BOD7 = 315.9066 g/m3; 371092.6825 kg/y; 50.8346 g/cap.day
 COD total = 736.7326 g/m3; 865433.3458 kg/y; 118.5525 g/cap.day
 COD biosol= 198.5734 g/m3; 233262.375 kg/y; 31.9537 g/cap.day
 COD insol = 51.846 g/m3; 60903.024 kg/y; 8.3429 g/cap.day
 COD biopart = 245.6727 g/m3; 288589.5312 kg/y; 39.5328 g/cap.day
 COD inpart = 240.6406 g/m3; 282678.4156 kg/y; 38.7231 g/cap.day
 Sum of COD-fractions = 865433.3458 kg/y

Volatile solids (VS) = 519.423 g/m3; 610161.6144 kg/y; 83.5838 g/cap.day
 Suspended solids (TSS) = 367.1575 g/m3; 431296.7058 kg/y; 59.0817 g/cap.day
 Dissolved solids (TS-TSS) = 514.604 g/m3; 604500.8387 kg/y; 82.8083 g/cap.day
 Fixed solids (TS-VS) = 362.3386 g/m3; 425635.9301 kg/y; 58.3063 g/cap.day
 Total solids (TS) = 881.7615 g/m3; 1035797.5445 kg/y; 141.8901 g/cap.day
 H2O = 1173655442.86 kg/y; 160.7747 kg/cap.day
 Total volume = 1174691.2404 m3/y; 3218.3322 m3/day
 VS content = 0.051942 %
 TSS content = 0.036716 %
 TS content = 0.088176 %

Total nitrogen = 85.9186 g/m3; 100927.7998 kg/y; 13.8257 g/cap.day
 N-NH3 & N-NH4 = 65.7028 g/m3; 77180.502 kg/y; 10.5727 g/cap.day
 N-NO3 = 0.11674 g/m3; 137.1374 kg/y; 0.018786 g/cap.day
 N-N2O = 0 g/m3; 0 kg/y; 0 g/cap.day
 N-org,part = 10.4965 g/m3; 12330.178 kg/y; 1.6891 g/cap.day
 N-org,sol = 9.6025 g/m3; 11279.9824 kg/y; 1.5452 g/cap.day
 Sum of N-fractions = 100927.7998 kg/y
 N content per TSS (N-org,part/TSS) = 2.8589 %
 N content per TS (Total N/TS) = 9.744 %

Total sulphur = 18.6494 g/m3; 21907.3 kg/y; 3.001 g/cap.day
 SO4-S = 16.8343 g/m3; 19775.1191 kg/y; 2.7089 g/cap.day
 S particulate = 1.0656 g/m3; 1251.7699 kg/y; 0.17148 g/cap.day
 Sulfide HS-S = 0.74948 g/m3; 880.411 kg/y; 0.1206 g/cap.day
 Sum of S-fractions = 21907.3 kg/y
 S content per TSS (S particulate/TSS) = 0.29023 %
 S content per TS (Total S/TS) = 2.115 %

Total phosphorus = 11.9567 g/m3; 14045.3945 kg/y; 1.924 g/cap.day
 PO4-P = 7.2593 g/m3; 8527.4878 kg/y; 1.1681 g/cap.day
 P particulate = 4.6973 g/m3; 5517.9067 kg/y; 0.75588 g/cap.day
 Sum of P-fractions = 14045.3945 kg/y
 P content per TSS (P particulate/TSS) = 1.2794 %
 P content per TS (Total P/TS) = 1.356 %

Total potassium = 25.9694 g/m3; 30505.97 kg/y; 4.1789 g/cap.day
 Dissolved potassium = 23.909 g/m3; 28085.7325 kg/y; 3.8474 g/cap.day
 Organically bound potassium = 2.0603 g/m3; 2420.2375 kg/y; 0.33154 g/cap.day
 K content per TSS (Organically bound K/TSS) = 0.56115 %
 K content per TS (Total K/TS) = 2.9452 %

11

Concluding remarks

Developing and improving mathematical models is a never-ending task. However, at some point we must state that we accept the models in their current states and focus more on applying the models to the model-city scenarios. It is not until the models are tested on real-world cases that it is possible to state whether or not their behaviour appear relevant. The model validation work is the most important part of the entire modelling exercise. The example in Chapter 8 shows that the different models can now be interconnected and produce reasonable overall results.

Although the models describing the WWTP produce results that are reasonable, any results will certainly depend on how well the influent wastewater is characterised. Within the URWARE task group significant efforts have been made to characterize the different fractions of household wastewater (Jönsson *et al.*, 2005), in terms of urine, faeces and paper, grey water and organic household waste and also the contents of the drinking water. However, the fractions in the wastewater related to industrial wastewater and storm water has not been investigated to the same extent. Any URWARE user should make an effort to include the flows and components in these two pollution sources as well. Moreover, it is a well known fact that a significant amount of biological transformations occur within the sewer system, in particular in large sewer systems when the temperature is high. Consequently, a simple model describing biological transformations in the sewer system has been developed and should be used together with the more traditional WWTP models.

Issues related to modelling of heavy metals and exergy also remains to be solved. At this stage they are not explicitly included. For heavy metals a simple short-cut of the WWTP can be applied, i.e. the heavy metals of the influent wastewater are simply divided between the effluent water and sludge according to a fractionation matrix as these two streams leave the WWTP. It is also unclear how the remaining approximately 30 URWARE vector variables should be considered as they are not related to water systems or the behaviour of some of these substances within water systems is highly speculative. A user interface suitable for non-expert users have also been discussed. The generation of output data should be improved and focus on a few priority indicators.

Bypassing of wastewater at a WWTP is not an option explicitly included in the models. However, this can easily be implemented within the Simulink environment by simply using a flow splitter module and direct a fraction of the wastewater directly to the effluent flow and there add it together to the main flow stream via a flow combiner module. In order to investigate the influence of summer/winter conditions (in particular with regard to temperature effects on the biological processes) it may be useful to make several simulations using the same layout and same influent wastewater but adjust the temperature of the influent wastewater and investigate the different results. As URWARE is mainly developed for the purpose of analysing yearly averages this is an extra effort that may be required to ensure that the produced results are valid also during winter conditions (or to get an indication what the main bottlenecks during such conditions are).

As all models related to the WWTP have been rewritten (compared to the original ORWARE software) and have in the task group's opinion been improved in terms of reliability, transparency and flexibility it is now a relevant question whether the remaining ORWARE models used for incineration, spreading of nutrients on farmland, composting etc. are appropriate for the purpose of URWARE. In most cases, these models are simply used in simulations with their default set of parameters without much detailed analyses of the results. However, further development of the models related to processes outside the WWTP is beyond the scope of the URWARE task group.

12

References

- Balmer, P. (2004). Personal communication.
- Batstone, D.J., Keller, J., Angelidaki, I., Kalyuzhnyi, S.V., Pavlostathis, S.G., Rozzi, A., Sanders, W.T.M., Siegrist, H. and Vavilin, V.A. (2002). *Anaerobic Digestion Model No. 1*. IWA Scientific and Technical Report No. 13, IWA Publishing, London, UK.
- Christensen, T.H., Jansen, J. la C. and Jørgensen, O. (2003). Datarapport om sammansætning af biogaspotentiale i organisk dagrenovation. Miljøprojekt nr. 815, Miljøstyrelsen, Copenhagen, Denmark (in Danish).
- Copp J.B. (ed.) (2002). *The COST Simulation Benchmark — Description and Simulator Manual*. ISBN 92-894-1658-0, Office for Official Publications of the European Communities, Luxembourg.
- Copp, J.B., Jeppsson, U. and Rosen, C. (2003). Towards an ASM1 – ADM1 state variable interface for plant-wide wastewater treatment modeling. *Proc. Water Environment Federation Conference WEFTEC 2003*, Los Angeles, California, USA, 11-15 Oct. 2003.
- Dalemo, M. (1999). *Environmental Systems Analysis of Organic Waste Management – the ORWARE Model and the Sewage Plant and Anaerobic Digestion Submodels*. Doctoral thesis, ISBN 91-576-5453-0, Dept of Agricultural Engineering, Swedish University of Agricultural Sciences, Uppsala, Sweden.
- Ekama, G.A., Barnard, J.L., Günthert, F.W., Krebs, P., McCorquodale, J.A., Parker, D.S. and Wahlberg, E.J. (1997). *Secondary Settling Tanks: Theory, Modelling, Design and Operation*. Scientific and Technical Report No 6., IWA Publishing, London, UK.

- Gernaey, K.V., Jeppsson, U., Batstone, D.J. and Ingildsen, P. (2004). Impact of reactive settler models on simulated WWTP performance. *Proc. IWA 6th International Symposium on Systems Analysis and Integrated Assessment in Water Management*, Beijing, China, 3-5 Nov. 2004.
- Henze, H., Grady, Jr C.P.L., Gujer, W., Marais, G.v.R. and Matsuo, T. (1987). *Activated Sludge Model No. 1*. IWA Scientific and Technical Report No. 1, IWA Publishing, London, UK.
- Henze, M., Gujer, W., Mino, T. and van Loosdrecht, M. (2000). *Activated Sludge Models ASM1, ASM2, ASM2d and ASM3*. Scientific and Technical Report No 9., IWA Publishing, London, UK.
- Henze, M., Gujer, W., Mino, T., Matsuo, T., Wentzel, M.C., Marais, G.v.R. and van Loosdrecht, M.C.M. (1999). Activated sludge model no. 2d, ASM2d. *Wat. Sci. Tech.*, **39**(1), 165-182.
- Henze, M., Harremoës, P., Jansen, J. la C. and Arvin, E. (1995). *Wastewater treatment, biological and chemical processes*. Springer-Verlag, Berlin, Germany.
- Hellström, D. (2004). Personal communication.
- Hellström, D., Jeppsson, U. and Kärman, E. (1999). Systems analysis of sustainable urban water management – a first approach”. *Proc. 4th International Conference on Ecological Engineering for Wastewater Treatment – Managing the wastewater resource*, Ås, Norway, 7-11 June 1999.
- Hellström, D., Jeppsson, U. and Kärman, E. (2000). A framework for systems analysis of sustainable urban water management. *Environmental Impact Assessment Review*, **20**(3), 311-321.
- Huisman, J.L., Krebs, P. and Gujer, W. (2003). Integral and unified model for the sewer and wastewater treatment plant focusing on transformations. *Wat. Sci. Tech.*, **47**(12), 65-71.
- Hultman, B. (2004). Personal communication.
- Hydromantis (1999). *GPS-X Technical Reference*. Hydromantis Inc., Hamilton, Canada.
- Jansen, J. la C. (2004). Personal communication.
- Jeppsson, U. (1996). *Modelling Aspects of Wastewater Treatment Processes*. Doctoral thesis, ISBN 91-88934-00-4, Dept of Industrial Electrical Engineering and Automation (IEA), Lund University, Lund, Sweden.

- Jeppsson, U. and Diehl, S. (1996a). An evaluation of a dynamic model of the secondary clarifier. *Wat. Sci. Tech.*, **34**(5-6), 19-26.
- Jeppsson, U. and Diehl, S. (1996b). On the modelling of the dynamic propagation of biological components in the secondary clarifier. *Wat. Sci. Tech.*, **34**(5-6), 85-92.
- Jeppsson, U. and Hellström, D. (2001). Systems analysis for environmental assessment of urban water and wastewater systems. *Proc. IWA 2001 Berlin World Water Congress*, Berlin, Germany, 15-19 Oct. 2001.
- Jönsson, H., Baky, A., Jeppsson, U., Hellström, D. and Kärman, E. (2005). *Composition of urine, faeces, greywater and biowaste for utilisation in the URWARE model*. Urban Water Report 2005:6, Chalmers University of Technology, Göteborg, Sweden.
- Kennedy, T.J. (Ed.) (1997). *Energy Conservation in Wastewater Treatment Facilities*. WEF Manual of Practice No FD-2, Water Environment Federation, Alexandria, VA, USA.
- Kjellén, B.J. and Andersson, A.-C. (2002). *Energihandbok för avloppsreningsverk*. VA-Forsk Report 2002-2, Svenskt Vatten AB, Stockholm, Sweden (in Swedish).
- Malmqvist, P.-A. (1999). Sustainable urban water management. *Vatten*, **55**(1), 7-17.
- MathWorks (1996). *MATLAB® - the Language of Technical Computing, Using MATLAB*. The MathWorks, Inc., Natick, Massachusetts, USA.
- MathWorks (1997). *SIMULINK® - Dynamic System Simulation for MATLAB, Using SIMULINK*. The MathWorks, Inc., Natick, Massachusetts, USA.
- Metcalf & Eddy (1991). *Wastewater Engineering: Treatment, Disposal and Reuse*. 3rd ed., ISBN 0-07-041690-7, McGraw-Hill, New York, USA.
- Orhon, D. and Artan, N. (1994). *Modelling of Activated Sludge Systems*. ISBN 1-56676-101-8, Technomic Publishing Company, Inc., Lancaster, Pennsylvania, USA.
- Samuelsson, P., Ekman, M. and Carlsson, B. (2001). A JAVA based simulator of activated sludge processes. *Mathematics and Computers in Simulation*, **56**(4-5), 333-346.
- Svärd, Å. (2003). *Anaerobic Digestion of Urban Organic Waste – Evaluation of Potentials*. Licentiate's thesis, ISSN 1650-5050, Dept of Water and Environmental Engineering, Lund University, Lund, Sweden.

- Svärd, Å., Gruvberger, C., Lövstedt, C. and Jansen, J. la C. (2004). Potential for co-digestion of sludge from grease removal tanks together with sewage sludge. *Proc. IWA 4th World Water Congress and Exhibition*, Marrakech, Morocco, 20-24 Sept. 2004.
- Takács, I., Patry, G.G. and Nolasco, D. (1991). A dynamic model of the clarification thickening process. *Wat. Res.*, **25**(10), 1263-1271.
- Vanrolleghem, P.A., Rosen, C., Zaher, U., Copp, J.B., Benedetti, L., Ayesa, E. and Jeppsson, U. (2004). Continuity-based interfacing of models for wastewater systems described by Peterson matrices. *Proc. Anaerobic Digestion 2004: Anaerobic Bioconversion for Sustainability (ADI0)*, Montreal, Canada, 29 Aug. - 2 Sept. 2004.



Urban Water

Chalmers University of Technology

Gothenburg, Sweden

www.urbanwater.org