



LUND UNIVERSITY

Antenna matching for performance optimization in compact MIMO systems

Lau, Buon Kiong; Tian, Ruiyuan

Published in:
Microwave Exhibition and Workshop, 2007

2007

Document Version:
Peer reviewed version (aka post-print)

[Link to publication](#)

Citation for published version (APA):
Lau, B. K., & Tian, R. (2007). Antenna matching for performance optimization in compact MIMO systems. In *Microwave Exhibition and Workshop, 2007*

Total number of authors:
2

General rights

Unless other specific re-use rights are stated the following general rights apply:
Copyright and moral rights for the publications made accessible in the public portal are retained by the authors and/or other copyright owners and it is a condition of accessing publications that users recognise and abide by the legal requirements associated with these rights.

- Users may download and print one copy of any publication from the public portal for the purpose of private study or research.
- You may not further distribute the material or use it for any profit-making activity or commercial gain
- You may freely distribute the URL identifying the publication in the public portal

Read more about Creative commons licenses: <https://creativecommons.org/licenses/>

Take down policy

If you believe that this document breaches copyright please contact us providing details, and we will remove access to the work immediately and investigate your claim.

LUND UNIVERSITY

PO Box 117
221 00 Lund
+46 46-222 00 00

ANTENNA MATCHING FOR PERFORMANCE OPTIMIZATION IN COMPACT MIMO SYSTEMS

(Invited Paper)

Buon Kiong Lau, *Senior Member, IEEE*, and Ruiyuan Tian, *Student Member, IEEE*

Department of Electrical and Information Technology, Lund University, Sweden.

Email: {bkl,ruiyuan}@eit.lth.se

Abstract—The implementation of MIMO technology on compact mobile terminal devices poses a unique challenge for system designers. This is because it requires that multiple antennas be closely separated in a confined volume, which results in strong mutual coupling among the antennas and high spatial correlation for the signals. In this paper, we present a review on the latest developments of using uncoupled impedance matching networks to counteract performance degradation due to the aforesaid effects. Then, we extend our previous study of utilizing identical uncoupled matching networks to optimize performance by allowing them to be different across the antennas. The numerical examples reveal that the enlarged optimization search space is effective in improving the received power and correlation, whereas only a modest gain in channel capacity is observed.

Keywords—MIMO systems; compact; mutual coupling; capacity; correlation; impedance matching; optimization

I. INTRODUCTION

When the multiple-input multiple-output (MIMO) system was first conceived [1], the technology was ahead of its time and received little attention. However, with the impressive technological advances in the past two decades, the table has finally turned in favor of the technology. Today, the MIMO technology [2]-[6] is being standardized in important wireless communication systems such as IEEE802.11n, IEEE 802.16e, and 3G long term evolution (LTE). Notwithstanding, there remain design challenges for such a system, one of which is its implementation on compact mobile terminal devices. The difficulty stems from the strong electromagnetic coupling (or mutual coupling) among closely separated antenna elements, resulting in a loss of efficiency of the antenna system [7]. Moreover, the small separation distances among the spatial signal samplers (i.e., antenna elements) also result in a high correlation among the received signals. The loss of efficiency and high correlation, if unaccounted for, can lead to a detrimental decrease in the expected capacity gain from deploying MIMO. It is worth noting that even though mutual coupling can distort the antenna pattern at a moderate antenna separation distance [8] and lead to a reduced signal correlation, it only delays the inevitable drop in capacity with decreasing separation distance [9].

The rest of this paper is organized as follows. Section II gives a review of recent developments on the use of impedance matching for performance improvements, with a particular emphasis on uncoupled matching networks. In this context, we introduce an extension to our previous work. A summary of the MIMO system model in Z-parameter representation is the subject of Section III. Three performance metrics of interest, as well as uncoupled matching networks which optimize for each of these metrics are also briefly mentioned. A numerical comparison on the performance of MIMO systems with the existing vs. proposed uncoupled impedance matching networks is provided in Section IV. Section V concludes the paper.

II. REVIEW OF UNCOUPLED IMPEDANCE MATCHING

Conventionally, for single antenna systems, the problem of impedance mismatch is understood as the design of the input impedance of antennas to provide sufficiently low mismatch (typically -6 dB or -10 dB) with the 50-ohm feed cables across a certain frequency band(s), i.e., the impedance bandwidth. The condition of zero mismatch is provided by the well known complex conjugate match, where the input impedance is equal to the complex conjugate of the characteristic impedance of the cable. However, this approach is inadequate for multiple antenna systems, where the mismatch between the input impedance and the characteristic impedance of the feed cable gives no indication of the loss of efficiency via mutual coupling. For compact mobile terminal devices, the loss of efficiency through coupling dominates over the mismatch loss with the cable. Moreover, MIMO systems require *both* high efficiency and low signal correlation for good performance. This implies that the designers should also consider signal correlation, which is not only a function of antenna characteristics, but also the propagation environment.

Interestingly, a solution to this problem has been provided almost half a century ago by Haus and Adler [10] in the context of circuit theory, in the form of a multiport extension of the complex conjugate matching condition. Indeed, it was highlighted recently that the so-called *multiport conjugate (MC) match* can simultaneously offer *both* 100% efficiency and zero correlation in a uniform 3D angular power spectrum (APS) for *any* antenna separation [11], [12]. Practical circuit realizations for the MC match were also proposed [13], [14]. Unfortunately, this remarkable feature of the MC match is obtained at the costs of decreasing bandwidth for decreasing antenna separation distance (or increasing mutual coupling) [9], [15] and implementation difficulties [16].

It is partly for this reason that the uncoupled matching network was more carefully studied in [17]. The uncoupled matching network, also known as the individual port match [18], is characterized by no interconnection between the matching circuits connected to the antennas. Thus, the uncoupled networks can be represented by equivalent uncoupled matching loads at the antenna ports. In [17], it is demonstrated that it is possible to design the matching network for (the second order statistics of) a given propagation environment represented by an open-circuit correlation, so that it gives a low correlation or high received power. An earlier work [19] also presents related results, but only for received power, and real-valued antenna and load impedances are assumed. Further studies in [20] reveal that while optimum correlation and received power are sensitive to perturbations in the impedance matching network, the optimum capacity is more robust to such variations. Another conclusion of [20] is that different complex open-circuit correlations of the same absolute value have been found to give different results for the MIMO performance metrics of received power, output correlation, and mean capacity, indicating that significant discrepancies can arise from neglecting the phase of complex correlations.

A more comprehensive study of uncoupled matching network is performed in [18], where the performance of uncoupled matching networks in terms of received power, correlation and capacity is numerically evaluated over a range of separation distances for two closely coupled dipoles. In particular, matching networks which optimizes for the performance metrics of received power and capacity are considered. The results indicate that a tradeoff between the correlation and received power is necessary in order to achieve the maximum capacity. In other words, the correlation and received power of the matching networks with the optimum capacity degrade with respect to those of the matching networks with the optimum correlation and received power, respectively. Consistent to the finding of [20], the received power plays an increasingly dominant role in facilitating the optimum capacity as the antenna separation distance decreases. In addition, the strong influence of the propagation environment on the achievable performance gain with uncoupled matching is likewise unraveled [20].

In order to verify the analytical and simulation results in [17]-[20], an experimental study was performed in [21]. Whereas the study largely confirms these results, the relative received power (or gain) of the super-directivity characteristic [22] observed in [17]-[20] could not be precisely replicated in the experiments. This is mainly attributed to the significant ohmic power loss resulting from high current flow, and partly due to the difficulties in accurately localizing the narrow super-directivity peak. Nevertheless, though not explicitly shown in the paper, the *shape* of the measured antenna pattern is super-directive and is consistent with simulation results.

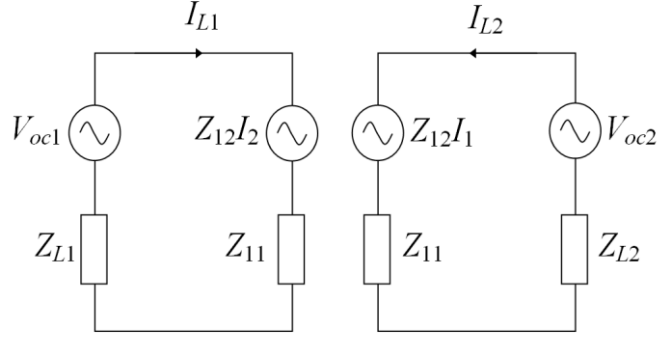

Figure 1. Equivalent circuit for receiver.

For convenience, the focus in the earlier studies of uncoupled matching network in [17]-[21] has been on the use of identical uncoupled matching networks (or equivalent loads), which constrains the optimization search space to only two dimensions (i.e. real and imaginary parts of the loads). On the other hand, if a different uncoupled matching network is allowed for each of the N antenna elements, then this flexibility requires that the search space be enlarged to $2N$. In this paper, we provide a first study into the effectiveness of such an approach in optimizing the different performance metrics of compact MIMO systems. Our concern here is on the relative performance gains possible through the increased flexibility afforded by different uncoupled matching networks and not on the efficiency of the optimization routine (e.g., complexity and speed) used to find the optimum points.

It should be noted that a related study [16] investigates the use of a “closed form solution” approach for maximizing the received power with uncoupled matching networks, which allows for different matching networks across the antennas. The results indicate that significant gains (relative to the self-impedance match) can be obtained from optimizing the received power, when the propagation environment demonstrates a directional bias, i.e., when the APS of the incident field is non-uniform. However, since the closed form expression may produce non passive loads, a numerical optimization is still required to constrain the loads to be passive. Moreover, it is not clear if the approach can give the global optimum for the received power in cases where a local optimum can occur [17].

III. MIMO SYSTEM MODEL

A. MIMO System Model in Z-parameter representation

A 2×2 MIMO system setup with identical vertically polarized half-wavelength ($\lambda/2$) electric dipole antennas is assumed. For simplicity, each of the two transmit antennas is complex conjugate matched and sufficiently separated from each other such that there is negligible coupling/correlation between them. Instead, we set the requirement of small antenna separation d on the receive end. The receiver consists of two dipole antennas, each terminated with an equivalent load impedance. The propagation environment between the transmitter and receiver is represented by the Kronecker model [23], with the channel matrix is given by

$$\mathbf{H}_{Ch} = \mathbf{\Psi}_R^{1/2} \mathbf{H}_{iid} (\mathbf{\Psi}_T^{1/2})^T, \quad (1)$$

where

$$\mathbf{\Psi}_R = \begin{bmatrix} 1 & \alpha \\ \alpha^* & 1 \end{bmatrix},$$

and $\mathbf{\Psi}_T = \mathbf{I}$ are the receive and transmit correlation matrices, respectively. Each entry of the 2×2 matrix \mathbf{H}_{iid} is a complex Gaussian random variable of zero mean and variance of 1, α is the correlation between the open-circuit voltages at the received antennas, and \mathbf{I} is the 2×2 identity matrix.

The equivalent circuit of the receiver is illustrated in Figure 1, where V_{oc1}, V_{oc2} (I_{L1}, I_{L2}) denote the open-circuit voltages (load currents) of antennas 1 and 2, respectively, Z_{11} the self impedance of antenna 1 (or antenna 2) and Z_{12} the mutual impedance between antennas 1 and 2, and Z_{L1}, Z_{L2} the equivalent load impedances as seen by antennas 1 and 2, respectively. For the transmitter, the circuit diagram is equivalent to Figure 1 – with V_{oc1}, V_{oc2} (I_{L1}, I_{L2}) replaced by V_{S1}, V_{S2} (I_{S1}, I_{S2}), which are voltage excitation sources (excitation currents) of transmit circuits 1 and 2, and Z_{L1}, Z_{L2} by the source impedance Z_S , since identical source impedance is assumed. In addition, following our earlier assumptions of the transmit circuits, $Z_{12} = 0$ and $Z_S = Z_{11}^*$. Thus, on the transmit side, the excitation currents are

$$\begin{bmatrix} I_{S1} \\ I_{S2} \end{bmatrix} = \frac{1}{2 \operatorname{Re}(Z_{11})} \begin{bmatrix} V_{S1} \\ V_{S2} \end{bmatrix}. \quad (2)$$

At the receiver, the excitation sources are the open-circuit voltages. The load voltages become

$$\begin{bmatrix} V_{L1} \\ V_{L2} \end{bmatrix} = \mathbf{Z}_L \begin{bmatrix} I_{L1} \\ I_{L2} \end{bmatrix} = \mathbf{Z}_L (\mathbf{Z}_L + \mathbf{Z}_R)^{-1} \begin{bmatrix} V_{oc1} \\ V_{oc2} \end{bmatrix}. \quad (3)$$

where $\mathbf{Z}_L = \begin{bmatrix} Z_{L1} & 0 \\ 0 & Z_{L2} \end{bmatrix}$ and $\mathbf{Z}_R = \begin{bmatrix} Z_{11} & Z_{12} \\ Z_{12} & Z_{11} \end{bmatrix}$. The above derivation is identical to [18], [20], except that the constraint $Z_{L1} = Z_{L2}$ is relaxed here.

Using the load voltage expression (3), closed form solutions for *total* mean received power (relative to that of a reference conjugate matched single antenna) and output correlation ρ (or correlation between the load voltages) can be derived in the same manner as in [18], [20]. Likewise, the expression for MIMO capacity (assuming no CSI at the transmitter) can also be obtained. Mean capacity can be calculated from independent realizations of the channel (1) or by using the closed-form expressions of [24]. As in [18], we adopt the latter approach.

It was observed in [17]-[20] that the received power can have up to two maxima with passive matching loads when $Z_{L1} = Z_{L2}$, whereas a single maximum is observed for the mean capacity. On the other hand, there can be infinitely many [17] or a finite number [20] of solutions for the criterion of minimum correlation, depending on the propagation environment. In this paper, we consider three types of optimum matching networks, giving (i) maximum received power, (ii) minimum output correlation, and (iii) maximum mean capacity, respectively. We note that since local extrema can exist in some cases, the simple optimization routine used can result in a local solution, and not the global solution. For the purpose of this study, it is not critical to find the global solution. Thus, we use the practical approach of repeating the search with different starting points in order to find the best possible solution. This is in contrast with [17]-[20], where an exhaustive search can be easily performed over a sufficiently dense two-dimensional (2D) search grid.

IV. NUMERICAL STUDY

In this section, we investigate the relative merits of the proposed extension for several propagation environments: uniform 2D APS and three Laplacian 2D APS [6] with $|\alpha| = 0.98$ but having different means of $\mu = 0^\circ$ (broadside), 45° , 90° and corresponding standard deviations of $\sigma = 20.6^\circ, 28.3^\circ, 40.6^\circ$. We assume thin dipoles with $Z_{11} = 73.1 + j43 \Omega$ and $Z_{12} = 67.3 + j7.6 \Omega$ at the antenna separation distance $d = 0.1\lambda$. A reference SNR of 20 dB is assumed for the mean capacity calculations. For the case of $Z_{L1} = Z_{L2}$, Table 1 shows the optimum values obtained by optimizing the uncoupled matching network for the three corresponding performance metrics. In contrast, Table 2 shows the optimum values obtained by optimizing the uncoupled matching network for the three corresponding performance metrics with the proposed extension of allowing arbitrary Z_{L1}, Z_{L2} .

As can be seen in Table 1, it is possible to improve the total received power of the dipole pairs in all four propagation environments relative to that of a single dipole (0 dB corresponds to the power received by an optimally matched, isolated dipole). The output correlation increases as the mean of the Laplacian distribution is moved away from the array broadside towards the endfire, despite that the magnitude of the open-circuit correlation is kept to $|\alpha| = 0.98$ by adjusting the standard deviations (see [20]). The mean capacity does not vary significantly for the different APS, with a maximum variation of 0.44 bits/s/Hz.

Table 1. Optimized performance of the uncoupled matching network for three types of matching networks with $Z_{L1} = Z_{L2}$.

	Total Mean Received Power for Max Power Match (dB)	Output Correlation for Min Correlation Match	Mean Capacity for Max Capacity Match (bits/s/Hz)
Uniform 2D APS	0.89	0	9.80
Laplacian with (0°, 20.6°)	0.29	0	8.11
Laplacian with (45°, 28.3°)	1.42	0.49	8.33
Laplacian with (90°, 40.6°)	2.94	0.59	8.48

Table 2. Optimized performance of the uncoupled matching network for three types of matching networks with the proposed extension (arbitrary Z_{L1}, Z_{L2}).

	Total Mean Received Power for Max Power Match (dB)	Output Correlation for Min Correlation Match	Mean Capacity for Max Capacity Match (bits/s/Hz)
Uniform 2D APS	0.89	0	9.80
Laplacian with (0°, 20.6°)	0.29	0	8.11
Laplacian with (45°, 28.3°)	3.23	0	8.42
Laplacian with (90°, 40.6°)	4.31	0.03	8.59

Comparing with Table 2, it is observed that for the uniform 2D APS and the broadside Laplacian APS, no performance improvement can be obtained by introducing full flexibility into the optimization variables of Z_{L1}, Z_{L2} . This is because these distributions are symmetrical about the array broadside, which is a good match to the antenna patterns with a reflection symmetry, as synthesized by having $Z_{L1} = Z_{L2}$. Therefore, the optimum solution is found within the more limited search space of $Z_{L1} = Z_{L2}$. In contrast, sizeable gains in received power of 1.8 dB and 1.4 dB are obtained with the proposed extension for the two cases of non-symmetrical Laplacian APS, since asymmetrical antenna patterns may now be synthesized by the uncoupled matching network to take advantage of the non-symmetrical APS. The large improvements in the output correlation for the non-symmetrical Laplacian APS cases are likewise attributed to the increased flexibility in synthesizing the antenna patterns. Nevertheless, only a small gain (of around 0.1 bits/s/Hz) in mean capacity obtained with the proposed extension. This is partly because the improvements in received power and output correlation do not occur at the same optimum load conditions. As pointed out in [18], a tradeoff between the received power and correlation is observed when the mean capacity is at its maximum.

V. CONCLUSIONS

In this contribution, we provide a review of the latest developments in the use of uncoupled matching networks for performance improvements in compact MIMO systems. In addition, we also propose a more flexible approach to designing the uncoupled matching networks. The numerical examples demonstrate that the approach can give significant benefits to received power and correlation when the APS is asymmetrical with respect to the array broadside, which indicates that the increased flexibility facilitates a better match between the antenna patterns and the asymmetrical propagation environment. Nevertheless, the necessary tradeoff between the received power and correlation in the optimum capacity performance results in only a modest capacity improvement with the proposed extension.

REFERENCES

- [1] J. Winters, "On the capacity of radio communication systems with diversity in a Rayleigh fading environment," *IEEE J. Select. Areas Commun.*, vol. SAC-5, pp.871-878, Jun. 1987.
- [2] I. E. Telatar, "Capacity of multi-antenna Gaussian channels," *European Trans. Telecommun.*, vol. 10, pp. 585-595, 1999.
- [3] G. J. Foschini and M. J. Gans, "On limits of wireless communications in a fading environment when using multiple antennas," *Wireless Personal Communications* (Kluwer Academic Publishers), vol. 6, pp. 311-335, Mar. 1998.
- [4] D. Gesbert, M. Shafi, D. S. Shiu, P. J. Smith, and A. Naguib, "From theory to practice: an overview of MIMO space-time coded wireless systems," *IEEE J. Select. Areas Commun.*, vol. 21, no. 3, pp. 281-302, Apr. 2003.
- [5] S. N. Diggavi, N. Al-Dhahir, A. Stamoulis, and A. R. Calderbank, "Great expectations: The value of spatial diversity in wireless networks," *Proc. IEEE*, vol. 92, pp. 219-270, Feb. 2004.
- [6] A. F. Molisch, *Wireless Communications*, IEEE-Press - Wiley, 2005.
- [7] P. S. Kildal and K. Rosengren, "Electromagnetic analysis of effective and apparent diversity gain of two parallel dipoles," *IEEE Antennas and Wireless Propagat. Lett.*, vol. 2, no. 1, pp. 9-13, 2003.
- [8] R. G. Vaughan and N. L. Scott, "Closely spaced monopoles for mobile communications," *Radio Science*, vol. 28, pp. 1259-1266, Nov-Dec 1993.
- [9] B. K. Lau, S. M. S. Ow, G. Kristensson, and A. F. Molisch, "Capacity analysis for compact MIMO systems", in *Proc. IEEE Vehicular Technology Conference Spring*, vol. 1, pp. 165-170, Stockholm, Sweden, May 30-Jun. 1, 2005.
- [10] H. A. Haus and R. B. Adler, *Circuit Theory of Linear Noisy Networks*, Wiley, 1959.
- [11] J. W. Wallace and M. A. Jensen, "Termination-dependent diversity performance of coupled antennas: Network theory analysis," *IEEE Trans. Antennas Propagat.*, vol. 52, pp. 98-105, Jan. 2004.
- [12] J. W. Wallace and M. A. Jensen, "Mutual coupling in MIMO wireless systems: a rigorous network theory analysis," *IEEE Trans. Wireless Commun.*, vol. 3, pp. 1317-1325, Jul. 2004.
- [13] H. J. Chaloupka and X. Wang, "Novel approach for diversity and MIMO antennas at small mobile platforms," in *Proc. IEEE International Symposium on Personal, Indoor, and Mobile Radio Communications (PIMRC)*, vol. 1, pp. 637-642, Barcelona, Spain, 5-8 Sep. 2004.
- [14] S. Dossche, S. Blanch, and J. Romeu, "Optimum antenna matching to minimise signal correlation on a two-port antenna diversity system," *Electronic Lett.*, vol. 40, no. 19, pp. 1164-1165, 16 Sep. 2004.
- [15] B. K. Lau, J. B. Andersen, G. Kristensson and A. F. Molisch, "Impact of matching network on bandwidth of compact antenna arrays," *IEEE Trans. Antennas Propagat.*, vol. 54, no. 11, pp. 3225-3238, Nov. 2006.
- [16] M. A. Jensen and B. Booth, "Optimal uncoupled impedance matching for coupled MIMO arrays," in *Proc. European Conference on Antennas and Propagation (EuCAP)*, Nice, France, 6-10 Nov. 2006.
- [17] J. B. Andersen and B. K. Lau, "On closely coupled dipoles in a random field," *IEEE Antennas and Wireless Propagat. Lett.*, vol. 5, no. 1, pp. 73-75, 2006.
- [18] B. K. Lau, J. B. Andersen, G. Kristensson and A. F. Molisch, "Antenna matching for capacity maximization in compact MIMO systems," in *Proc. International Symposium on Wireless Communications Systems (ISWCS)*, Valencia, Spain, 5-8 Sep. 2006.
- [19] R. G. Vaughan and J. B. Andersen, "Antenna diversity in mobile communications," *IEEE Trans. Vehic. Technol.*, vol. VT-36, no. 4, pp. 149-172, Nov. 1987.
- [20] B. K. Lau and J. B. Andersen, "On closely coupled dipoles with load matching in a random field," in *Proc. IEEE International Symposium on Personal, Indoor, and Mobile Radio Communications (PIMRC)*, Helsinki, Finland, 11-14 Sep. 2006.
- [21] Y. Fei, B. K. Lau, A. Sunesson, A. J. Johansson, J. B. Andersen, and J. S. Thompson, "Experiments of closely coupled monopoles with load matching in a random field" in *Proc. European Conference on Antennas and Propagation (EuCAP)*, Nice, France, 6-10 Nov. 2006.
- [22] R. Harrington, "Antenna excitation for maximum gain," *IEEE Trans. Antennas Propagat.*, vol. AP-13, pp. 896-903, Nov. 1965.
- [23] J. P. Kermaol, L. Schumacher, K. I. Pedersen, P. E. Mogensen, and F. Frederiksen, "A stochastic MIMO radio channel model with experimental validation," *IEEE J. Select. Areas Commun.*, vol. 20, no. 6, pp. 1211-1226, Aug. 2002.
- [24] G. Alfano, A. M. Tulino, A. Iozano, and S. Verdu, "Capacity of MIMO channels with one-sided correlation," in *Proc. International Symposium on Spread Spectrum Techniques and Applications (ISSSTA)*, vol. 1, pp. 515-519, Sydney, Australia, 30 Aug.-2 Sep. 2004.