



LUND UNIVERSITY

A Finance Model for the Built Cultural Heritage - Proposals for improvements of future Heritage Economics

Pålsson Skarin, Ingela

2011

[Link to publication](#)

Citation for published version (APA):

Pålsson Skarin, I. (2011). *A Finance Model for the Built Cultural Heritage - Proposals for improvements of future Heritage Economics*.

Total number of authors:

1

General rights

Unless other specific re-use rights are stated the following general rights apply:

Copyright and moral rights for the publications made accessible in the public portal are retained by the authors and/or other copyright owners and it is a condition of accessing publications that users recognise and abide by the legal requirements associated with these rights.

- Users may download and print one copy of any publication from the public portal for the purpose of private study or research.
- You may not further distribute the material or use it for any profit-making activity or commercial gain
- You may freely distribute the URL identifying the publication in the public portal

Read more about Creative commons licenses: <https://creativecommons.org/licenses/>

Take down policy

If you believe that this document breaches copyright please contact us providing details, and we will remove access to the work immediately and investigate your claim.

LUND UNIVERSITY

PO Box 117
221 00 Lund
+46 46-222 00 00

A Finance Model for the Built Cultural Heritage

– Proposals for improvements of future
heritage economics

Ingela Pålsson Skarin

A Finance Model for the Built Cultural Heritage
- Proposals for improvements of future heritage economics
© 2011 Ingela Pålsson Skarin
All rights reserved

Cover; (from top left) Frauenkirche in Dresden 2007, Koscol Mariacki 1997, St. Jakobi Kirche 2009, Medieval façade in Vilnius 1997, the Parthenon Mosque, Brickwork at Darab al-Ahmar in Cairo, the Russian theatre in Vilnius 1997, Rossewitz Palace 1997, Svc. Mergeles Marijos Basznycia 1997.

Printed by Media-Tryck, Lund 2011

Architectural Conservation and Restoration
Department of Architecture and Built Environment
Faculty of Engineering
Lund University
PO Box 118
SE- 221 00 Lund
Sweden
<http://www.bv.lth.se>

ISBN 978-91-7740-103-2



In Remembrance of
Bertil och Erika

Preface

“Who are you? I am death. Have you come to get me? I have already been walking by your side a long time...”

This dialogue originates from one of the most famous scenes in *The Seventh Seal*; the film which would turn out to be the international break-through for the Swedish film director Ingmar Bergman in the 1950's. The inheritance Bergman left behind as a professional film producer, on the Island of Fårö, today depends on the benevolence of three foundations. Donations from private financiers, EU funding, public subsidy and the local municipality have so far managed to preserve the film archives, Ingmar Bergman's villa and to establish public access to these assets, during the four years which have passed since Bergman's death. Now, the money is spent and the future prospects for securing the legacy of this film icon of the 20th century, is alas uncertain. For what reason is the memory of Sweden's internationally most celebrated filmmaker pioneers of its time, not secured financially?

The intention of this doctoral thesis has been to scrutinise, explain and detect means for initiating the mechanism of heritage funding. However, in this study the inheritance in focus is not from the world of films, but that of historical buildings, though both forms jointly have the capacity to pass on images of the past to us.

The manner in which people value films or buildings will always decide its price, i.e. what one is prepared to pay for it or to support it with financially. Important to see is still that those pecuniary contributions will not only become available as cash alone, but have numerous expressions. It is nevertheless fundamental that all kinds of economic behaviour will result in appreciation, or paybacks, which is why inclusive value expressions need to be acknowledged and promoted. Every man is unique and times are continuously changing.

In spite of the fact that I am a practicing architect who has had the good fortune to experience building conservation both in Germany, Denmark and Sweden, the main focus of this thesis is heritage funding and economy. This is due to the fact that no preservation works can ever be launched unless we professionals, who endorse the architecturally diverse society of the future, which includes historic buildings as well, know how to persuade other parties, to provide vital financial assistance.

Moreover, the many visits I made to building conservation sites, in former Eastern Europe in the 1990s, have made me realise that any behaviour aiming at contributing to preserve the local built cultural heritage, such as heritage funding, has more significance for people in a community, on numerous levels as a uniting icon, than merely securing structures, especially when you put them to good use. The impact which the preserved built culture supposedly has even for economic development indicates that heritage funding could be a most sustainable finance aid, not least for the third world countries.

This is the reason why the mechanism of heritage funding has been relevant for me to explore and not least to explain the roots of today's cultural funding policy in Sweden.

Skånör September 2011

Acknowledgements

This thesis would not have been possible to complete unless professionals in the field of building conservation actual practice, had so generously contributed with their time, and in interviews, introduced me to fascinating building conservation sites during my Licentiate Study 1997-2000, Study 1. This is why I wish to thank; Giédre Filipavichéne and colleagues at the Paminklu Restauravimo Institutas in Vilnius, Lithuania. In Poland; Tomasz Wolender at the PSOZ Wojewodski Oddziat Szczecinski. In Germany; Dieter Zander, as well as Bettina Gnekow, Landesamt für Denkmalpflege, Schwerin and not least Bent Böhnke. In Denmark; Mette Mæaegaard. Nilsen, also Hans Munk-Hansen and in Sweden Ove Hidemark.

Study 2, in 2004, included inspiring meetings as well and interviews, which is why thanks therefore are directed to; Sara Northey at National Trust, but also to Helen Munger at Heritage Lottery Fund, London, Great Britain. In Norway, Francien Lampe with colleagues, Riksantikvaren, Oslo and not least to Maire Mattinen at the Museiverket in Helsinki, Finland. Additionally, thank you Inger Strömberg for your contribution, when accompanying me for a while on this academic journey.

From 2008, involved new contacts with stakeholders within heritage funding. I especially wish to thank; Peg Breen and Alexander Herrerra, at the New York Landmarks Conservancy in New York, Christian Andersen at Realdania Copenhagen, Jürgen Klemisch at Brandenburger Schlösser and Lena Simonsson at the Swedish National Property Board. The many more, than the above mentioned, to whom I am so grateful, they have been listed in the References.

At the Department of Architecture and Built Environment, Faculty of Engineering, Lund University; first of all I would like to thank my supervisor Professor Kerstin Barup. I am grateful for your guidance and expertise from the field of Building Conservation practice and for given me free hands. My gratitude is also directed to Jenny Hellström, Anna Walöö and Thorbörn Laike, thank you all for your beneficial feedback at seminars. Additionally, Gunilla Kellgren and Hans Follin, thanks for helping out with the administrative issues.

For the inspirational guidance into the field of economics, I wish thank Professor Hans Landström at the Institute of Economic Research, Lund University for your initial assistance. Karin Forseke, Deputy Chairman at British FSA, thank you for adding the international perspective of the investment market. Professor

Charlotta Mellander at Jönköping International Business School, I appreciate your brief, but vital contribution. Finally, Katja Lindkvist associate senior lecturer at the Department of Service Management, Lund University, thanks a million, for your constructive critique, input and feedback. Your combined qualification, such as an economist and art historian, made our acquaintance mean a lot to me.

Julian Holden, English Heritage, thank you for the important contribution to the study, by enlightening me more on the British perspective of building conservation. Christer Gustafsson, Regional Curator of Halland, thank you ever so much for your constructive critique and inspiring discussions, as opponent during my final seminar.

Vanessa Poole Jönsson, a million thanks for helping me tidying up my English writing, with its German roots, I would not have managed without your support. Bianca Davidsson, thanks for this contact.

Konrad Fisher, you are my role model of the restoration architect. You introduced me to the world of building conservation, which fitted my archaeology background like a glove. In the early 1980's, as my boss at first, you are now my very dear friend and colleague. Your profound skills enable you to accomplish high quality building conservation even though, or especially when, funding is inadequate, which was often the case in former East Germany. This fact, and our trips in these regions, inspired me to this doctorate study, that began with scrutinizing the effects of the money flow, from West to East for building conservation projects, during the 1990's. Konrad, I cannot thank you enough.

Last but not least, I am thankful to my beloved family of Sonja, Angelika and Ulla with families and the smaller one; Ulf, Hanne Truls and Joar, thank you all for your encouragement and patience.

Contributions for research and travel are gratefully received from:
Magna Bergvall Stiftelse
Crafoordska Siftelsen
Formas

Abstract

The new role of built cultural heritage, as an economic asset for development strategies and the widened definition of built heritage as a concept-, explains today's affluence of sites. These can only be guaranteed with sufficient heritage funding. Financers' inducement to fund cultural heritage depends on that heritage's current value estimation and only highly revered sites qualify for support. Case studies imply that values are incessantly present in heritage and so these can be re-established when the right external conditions, or actions, arise. The assessment i.e. reflects the human perception of values projected onto buildings and not the physical characteristics of the heritage itself. This is way it is possible to modify finance incentive conditions. Finance models are needed but prototypes of such finance models are lacking.

This inquiry aspires to supplement the findings of Cultural Economics, but from the viewpoint of actual building conservation practice. The aim of this doctoral thesis is to investigate the prospects of securing the successful future of built heritage by proposing a value stabilizing finance model, based on; the acquiring, the economizing and the assuring of heritage funding. The strategy of this inquiry involves five steps.

Accelerators proved to determine all aspects of the heritage finance model, since these accelerators stabilize the values of built heritage sites by revealing the payback capacity of financial commitments to that heritage. Heritage funding in Sweden has stagnated due to weak emotional and financial accelerators, which means built heritage is at risk of falling into decay.

The suggested contribution of this inquiry is the exploratory analysis of the mechanisms behind heritage funding including its accelerators, hence introducing new terminology into building conservation instigated by the idiom of economics, which could ease future strategic planning of heritage funding.

Abbreviations

BPT	Building Preservation Trust
CBA	Cost-Benefit Analysis
CVM	Contingent Valuation Methodology
DSD	Deutsche Stiftung Denkmalschutz
ICOM	International Council of Museums
ICOMOS	International Council of Monuments and Sites
ICCROM	International Centre for the Study of the Preservation and Restoration of Cultural Property
NGO	Non-governmental organisation
NLC	New York Landmarks Conservancy
NT	National Trust
NPC	National Park Service
PP PKZ	Przedsiębiorstwo Państwowe Pracownia Konserwacji Zabytków
ROT	Restaurering, ombyggnad och tillbyggnad
SFV	Statens Fastighetsverk
TCM	Travel Costs Method
UNESCO	United Nations Educational, Scientific, and Cultural Organization
WMW	World Monuments Watch
WHF	World Heritage Fund
WHL	World Heritage List
WMF	World Monuments Fund
WCCD	World Commission on Culture and Development

Table of contents

Preface	5
Acknowledgements	7
Abstract	9
Abbreviations	10
1. Introduction	15
1.1 Dissertation Proposal	15
1.2 Foundation for the research questions	16
1.3 The problems; acute finance deficit due to rising costs and income loss	20
1.4 The solutions; demolition, new finance or cost reduction	25
1.5 The research questions defined	33
1.6 The research field	34
1.7 Research study overview; justification, contribution, limitation and chronology	42
1.8 Definitions	45
1.9 Disposition of the thesis	47
2.0 Publications	49
2. Methodological approach	57
2.1 Introduction	57
2.2 System of inquiry	57
2.3 Strategies	60
2.4 Tactics; Step 1: Analysing heritage economics in practice	63
2.5 Tactics; steps 2 to 5	68
2.6 The heritage finance model assumption	82
2.7 Summary	83
3 Value	87
3.1 Introduction	87
3.2 Definition of Value	87
3.3 Developing a value scale in theory	95
3.4 Comparative tests of the H ₃ UNS concept	123
3.5 Tests of vale concept in practice	126
3.6 Summary	131

4. Acquiring private funding	141
4.1 Introduction	141
4.2 Origin	142
4.3 Methods	166
4.4 Accelerators	171
4.5 Sustainability	178
4.6 Summary	182
5. Acquiring public funding	197
5.1 Introduction	197
5.2 Origin	197
5.3 Methods	207
5.4 Accelerators	217
5.5 Sustainability	225
5.6 Summary	231
6. Acquiring alternative funding –Investment market, lottery funds, donators	241
6.1 Introduction	241
6.2 Investment market	242
6.3 Methods	246
6.4 Accelerators	248
6.5 Sustainability	250
6.6 Lottery funds	252
6.7 Donors	258
6.8 Summary	263
7. Economizing and Assuring funding	271
7.1 Introduction	271
7.2 Step 4; Economizing funding (C_{SAP})	
– Intentional distribution and vertical archaeology	271
7.3 Step 5; Assuring funding (V_b)	
– employing empirical experience and the accelerators	279
7.4 Three case studies; – St. Jakobi Church, Rossewiz palace, Murray’s Mills	281
7.5 The use of Economizing funding in the case studies	285
7.6 The use of Assuring funding in the case studies	291
7.7 Summary	293
8. A Finance model for the built cultural heritage	301
Summary, discussion and final conclusions	301
8.1 Introduction	301
8.2 The topics of inquiry –to bridge heritage economics	301
8.3 Step 1; analysing heritage economics in practice	302
8.4 Step 2; assuming a value stabilizing heritage finance model	305
8.5 Step 3; acquiring funding	306

8.6 Step 4; economizing funding	319
8.7 Step 5; assuring funding	323
8.8 The notion of value	324
8.8 Final conclusions	341
8.9 Future research	345
Summary	353
References	355
Published literature	355
Reports, Articles, Papers and Brochures	358
Archive materials	360
Oral sources; interviews	361
Web-based sources	364
Illustrations	367

Paper 1. Ingela Pålsson. Skarin "Models for an objective evaluation of Restorations"
Proc. Conference Documentation and Conservation of Wooden Towns, NorFa, Tallinn
September 1999.

Paper 2. Ingela Pålsson. Skarin "A comparative study of the financial support in twelve
restoration projects from Denmark, Germany, Great Britain, Norway, Finland and
Sweden", Proc. Conference International expert seminar on the economics of heritage
preservation, Helsinki December 12-13, 2005.

Paper 3. Ingela Pålsson. Skarin "New Finance models for the Built Cultural Heritage",
Proc. Conference CHRESP The 8th European Conference on Research for Protection,
Conservation and Enhancement of Cultural Heritage, Ljubljana 10-12 November
2008.

Appendix 1. Step 1 Analysing Heritage economics in practice 1990-2004.

Appendix 2. International charters – cites on value and financial issues.

Appendix 3. Tests of vale concept in practice; Unnerbäck and H₃UNS.

Appendix 4. Distinctions of national policy; public and private-public directions.

1. Introduction

1.1 Dissertation Proposal

Never have there been as many registered, irreplaceable, built cultural heritage sites worldwide. Our affluence of recognized cultural assets can as yet only be guaranteed on condition they receive regular maintenance and therefore adequate funding for this purpose, is a must. How can this be achieved? To meet the increasing finance deficit in heritage economics, the aim of this doctoral thesis is to propose a new approach to enhancing fiscal resources for built cultural heritage; the heritage finance model. This management model comprises the acquiring of funding, economizing of funding and assuring of future funding, all requiring that the values in built cultural heritage be stabilized. Politicians, authorities, financiers and citizens active in managing the protection of European built cultural heritage in general, and Swedish legacy in particular, have been taken into consideration.

This thesis is based on empirical case studies of building conservations in eight countries in the period 1990 to 2004, hence signifying a unique time era. From 1990 onwards, suddenly the neglected, but still intact built legacy of Eastern Europe became unexpectedly accessible, meaning extensive sums of funding from the West were now allocated for its protection. Unique effects on the conservation process by the two major funding sources; public and private, could therefore be observed. More recent building conservations are also discussed. Nations represented in the study are; Denmark, Finland, Germany, Great Britain, Lithuania, Norway, Poland and Sweden. The United States, with the city of New York, is included as well since it exemplifies an exclusive heritage funding strategy.

The suggested contribution of this inquiry is the exploratory analysis of the mechanisms behind heritage funding including its accelerators, hence introducing new terminology into building conservation instigated by the idiom of economics. Crossing disciplines could improve contact between the stakeholders accountable, thus aspiring to ease future policy decisions and future strategic planning of heritage funding.

The intention is furthermore that this suggested finance model could be applied for improving heritage economics in third world countries. Today this factor is more important than ever, given that the explicit role of culture, such as

tangible built heritage, as an asset for development strategies, was proclaimed by the UN in 1995 to be conceptually intertwined with progress in any society.

“In a fundamental sense the notion of “value” is the origin and motivation for all economic behaviour” (David Throsby 2001)¹

1.2 Foundation for the research questions

1.2.1 Maglarp and Allhelgona; demolition or investment

On the third of September 2007, demolition began of New Maglarp Church in the countryside of Southern Sweden, less than 100 years after the church's inauguration. For the first time in Sweden a consecrated building² was torn down, although it had legally been protected since the 1940's³. It was lack of funds and accelerating maintenance costs, which had finally forced the Maglarp parish in 1996 to apply to the county administration⁴ for demolition.

When it was newly constructed in 1909, New Maglarp Church represented the stylistically pure neo-gothic style of the 19th century which aimed to represent a more dignified and prestigious temple, compatible with the growing wealth in society at the time⁵. Practical requirements for more seating, due to population growth and a spiritually more appropriate setting for worship, initiated furthermore a vast demolition of medieval churches concurrently⁶. However even though the old, original church of Maglarp from the 12th century had been spared, it was neglected and had begun to decay, since becoming regarded as an undesirable remnant of an obsolete farming culture⁷. Over three decades⁸ 100 architecturally planned and professionally built neo gothic churches were constructed according to the most recent building techniques of their time, in the Skåne region⁹. These imposing monuments, with their impeccable appearance, made any signs of decay intolerable. Moreover, weathering affected also the modern materials and the accurate interior distemper colouring. The consequence was unpredicted higher upkeep demands, which caused dismay. Together with the contemporary growing secularization in Sweden, these circumstances finally made people lose respect for, and interest in the lavish churches. As a result, even though electricity had been installed in the church in 1948, due to the decrease of parish members, New Maglarp Church fell into disuse and was closed up as early as¹⁰ in the 1970's and abandoned. The formerly imposing 'new' church from 1909 had now far outgrown its use, it was too large and the old medieval Maglarp Church was instead renovated and re-instated for local use.



121.1 *New Maglarp Church 2006 (left), during its demolition 2007 and the empty site in 2008 (right).*

The ensuing, short-lived maintenance work that followed on New Maglarp Church¹¹, had constructional consequences and caused accelerating damages to facades and vaults. For this reason an initial cost calculation was carried out in 1992¹², since the community was still bent on preserving the church¹³. In 1996, the regional authorities were informed¹⁴ that the parish had financial difficulties in raising the money required. Later the same year, the authorities received an application from the parish council, for permission to demolish New Maglarp Church. Such drastic action shocked the county antiquarian, the national board of antiquities and the news was briefly mentioned in the local media. A second cost estimation was once more carried out for New Maglarp Church in 1999, but this time assigned by the county administration. The outcome revealed a cost increase of four million SEK over a seven year period¹⁵. At the same time, the application for demolition was continually being tried in court, at all possible legal levels. The third cost calculation for a conservation of the New Maglarp in 2004 finally illustrated that an exponential cost increase of 25 million, had occurred, during the last five years¹⁶. This total sum was now four times higher than the previous one, though no additional incidents had occurred, other than general decay, which had worsened the building's condition. The bishopric and local municipality finally approved demotion, which all other authorities had rejected, and by the end of June 2005 the Supreme Court¹⁷ gave its consent as well. Alternative utilizations of the property were proposed to the community, during this time, but they were all dismissed, as the parish council considered them to be far too unrealistic, since the funding was regarded as insufficient¹⁸.

In April 2005 the Allhelgona church on the island of Ven, off the Western Swedish coast, was inaugurated as a museum, illustrating the life and achievements of the astronomer Tycho Brahe, an influential renaissance scientist¹⁹. The occasion was exceptional from a Swedish perspective since never before had a sacred building, a former public church, been adapted for a profane use²⁰. The adaptation provided the already existing museum with eight times as large an exhibition space and a visitor increase, five times higher²¹. Similar to Maglarp's New

church, the Allhelgona was also an example of these new sanctuaries of the neo-gothic style and was built during the great church expansion era, in 1899. This church, just like the one in Maglarp, had been abandoned, on account of a drop in parish members, and the mediaeval church, of St. Ibb had instead once more come into use. The church adaptation was initiated when a previously unknown technical problem in the Allhelgona was discerned²², which the parish was unable to cover financially. Solutions for other uses were then discussed as well as the possibility of perhaps selling the building. The opportunity came ten years later, when the expansion plans for the adjacent public Brahe museum were disclosed, and the sufficient amount of finance became available. The first expansion plans for the museum were originally for a new construction, which instead ended up with a symbolical purchase²³ of the neighbouring church, by the National property board (SFV). Even if the church was de-sacralised, and sold to SFV, the parish was still expected to fulfil specific demands, stipulated by the authorities, concerning the movables. The disagreements that followed only later could reach a final settlement in court²⁴. The present legal requirements, stipulated by the authorities on church movables, might turn out to be counter-productive to their intention, especially in light of the Maglarp case²⁵.



121.2 *The Maglarp's demolition in 2007 (left) and the Tycho Brahe museum in the Allhelgona church 2008; exterior (centre) and interior (right).*

The definition of built cultural heritage applied in this study is what the spirit of the age in society regards as an irreplaceable landmark, making us comprehend that we merely represent one point in time, with a past and a future to come. Man-made built legacy only claims this significance however by providing that two conditions are met; firstly, the remembrance significance is operational, which implies an active historical attachment and secondly, that it meets the obligations set up by society. The two church projects described above are both intended to illustrate how suddenly a monument's allure may drop; from manifesting future optimism for society to becoming merely boastful showpieces, in less than a century. However, in the case of the Allhelgona Church, the turn of events which led to a positive re-evaluation and new appreciation of the church

building, which swiftly transformed it into a highly valued recourse for further investments²⁶, is shown to be linked to external factors. At first glance, the two church buildings actually had several features in common, such as use, age, historic style, building techniques and closeness to a coastline, even as regards their technical state of repair²⁷. This implies that the loss of respect was not necessarily due to the churches' physical appearances, though this is often used as pretext. In fact the change actually depended more on how external and contextual so called *actions* projected the building legacy. The churches were then perceived or valued in a particular way by the parties involved. For this reason it is possible to alter the significance of a building, by refereeing to a temporary projection or image of the edifice, in contradiction to judging the value of the building alone, which is unalterable and finite. A hundred year old neo-gothic church can only ever be a neo-gothic church, but its approval or value to society can vary. The willingness to invest, which almost by chance, re-adapted the Allhelgona church as museum, was linked to the fact that the local community; the island of Ven, has always depended on summer tourism and the renaissance astronomer, who had contributed to its fame. Any region has a past to enlighten that in turn may contribute to its settings, but the museum suggested for New Maglarp Church in this case lacked the essential local bond of historical interest²⁸ and thus failed to motivate any funding. The question nevertheless remains; why was there no historical group taking pity on the church or private financiers willing to make a fiscal contribution?

Highly valued historic buildings are better qualified for funding investments, than ones which are lowly regarded, as the Maglarp-Allhelgona cases illustrated. The value recognition of the legacy seems to rest on what ways the contextual exterior *actions* will project the built cultural heritage and how these are perceived by people, that is to say, not on the built physical structures as such. For this reason the legacy may vary throughout time, but then again it is also possible for it to be adjusted or regulated. Our generation's mission is to protect and pass on our forefathers prior achievements, from science to art. This task has intensified, during the last century, regarding the built legacy, since the amount of indispensable buildings is constantly increasing. An inevitable growing funding deficit thereby can be predicted, since this is already a critical issue internationally. The escalating lack of finance urgently calls for a new value stabilizing device, for managing future funding demands. This is why methods for stabilizing value of historic buildings for attaining conceivable funding improvements, cost reductions and measures to ensure the future funding, are the core objectives of this dissertation.

1.3 The problems; acute finance deficit due to rising costs and income loss

The World Heritage Fund and the World Monuments Fund are the two major parties advocating and funding the built cultural heritage globally. Their continuous registration of monumental sites on the World Heritage List and the World Monuments Watch helps us to indentify the cultural treasures, but also the upcoming financial obligations. According to UNESCO’s World Heritage Lists statistics, cultural heritage worldwide of “outstanding universal value”, has grown by over 700 sites²⁹. The number of government, committed to monument protection³⁰ has also risen by 47 nations on average during the last three decades, since commencement 1978³¹ (see tables 13.1-3).

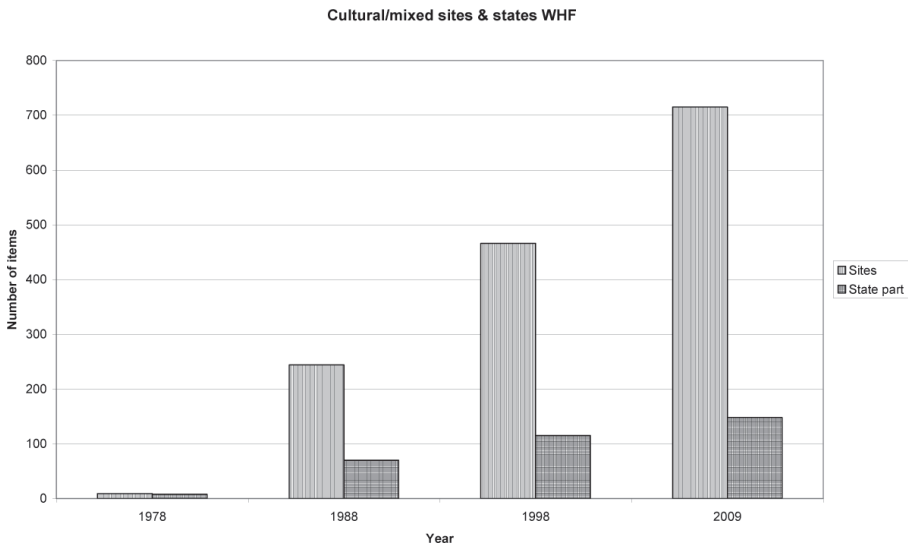

Table 13.1 UNESCO’s World Heritage List’s statistics of the increase in sites (striped) and the state parties, member states (checked).

The register, maintained by World Monuments Watch, of the 100 most endangered built cultural heritage sites implies also a growing awareness of preserving monuments globally. The number of sites has grown more than five times over the 14 years, to 637 in 2009, and the number of countries has increased by 74% since listing was first begun, in the mid 1990’s³² (table 13.2). The tendency of an augmented listing of historic buildings can also be observed when it comes to the individual nations, where even Sweden, known otherwise for its restricted

monument listing policy³³, has since the mid 1990's increased the number of recognised built heritage sites by 53%³⁴. This also includes a 17% growth, within a mere, three year recent period³⁵ (table 13.3). These figures only indicate the tip of the iceberg, since the recognition of built heritage as world, or national, monuments is always a result of a strict selection. Countless other historic buildings in each case have usually initially been considered, this includes buildings which are almost always equally significant. In other words; never before have there been as many irreplaceable built cultural heritage sites world wide, for us all to fund and preserve for the upcoming generations.

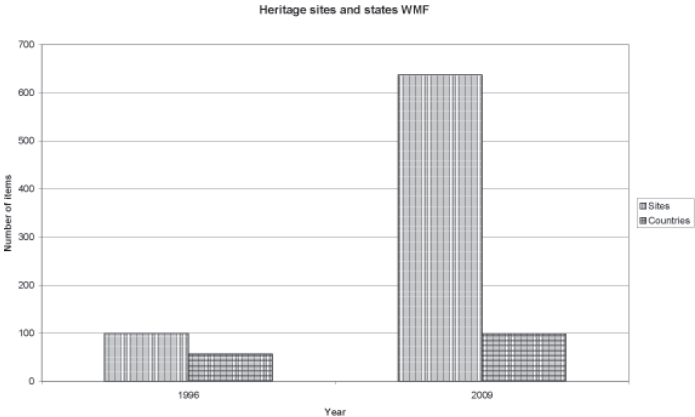

Table 13.2 World Monuments Watch sites (striped) and nations (checked).

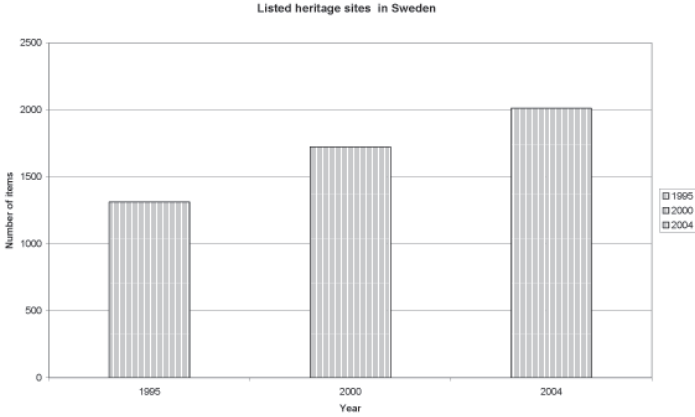

Table 13.3 Swedish increase of listed heritage sites.

The increased registrations of cultural heritage sites today, mirrors a growing respect for the past, but also a need to identify ourselves with our present. The expansion moreover can be regarded as a direct consequence of policy decisions made, which have affected the heritage economy. Two of the major aspects of importance for the present condition have been; first of all the new economic role of cultural heritage as assets, particularly for the third world countries and second of all, today's broadened definition of what is considered as indispensable built cultural heritage. The first issue involves the UN World Commission on Culture and Development (WCCD 1995)³⁶, which in 1995 proclaimed the explicit role of culture, such as built heritage, as a strategy against poverty in the third world countries, since the concepts of culture and of development are inextricably intertwined. At the UNESCO meetings, held in Stockholm 1998 and Florence 1999, international agreements were made regarding the vital impact of culture for economic development in future policy making³⁷. The World Bank has successfully developed these considerations further to help attain sustainable development. By integrating restoration of historic properties in their lending strategies, directed in programs, they have helped to secure the future of the existing assets so they generate future revenues, such as cultural tourism, in poor countries³⁸. The outcome of the Faro convention 2005³⁹ also induced the member states to agree on the fact that improved value of cultural assets has a positive economic impact on society. The increased contacts across borders have spread prosperity and awakened the commitment worldwide for the historical properties.

The second issue, and it is an aspect on the increase, involves the widened definition of what we today regard as cultural heritage. The extensive rise of monument sites is observable in the growth of legal protection acts and the landmark designations. Here in Europe, palaces were often the first built heritage ever to be listed, which often had already lost their initial use as representing symbols of power of the monarchy, due to political development, and had instead attained a more neutral public function, due to democratic reforms during the 19th century. The listing of palaces, with normative guidelines, made them legitimate to keep without requiring major interventions. The churches were the next to be legally protected, at the beginning of the 20th century, since there was a danger they be neglected, owing to a decline of their use in the new industrialised and secularized societies of the age. The post-war city redevelopments in the 1960's, re-building historic towns primarily to make them car-friendly and create car accessibility, began to jeopardize the anonymous architecture as well. It was only growing resistance against widespread demolition, which eventually brought legal protection to vernacular architecture too, by the end of the 20th century⁴⁰. The increasing number of built cultural heritage sites to protect therefore, offers a great affluence of cultural assets, which can only be guaranteed however, as long

as there is regular building maintenance and upkeep, a fact which requires that there be sufficient funding at hand.

The growing level of respect in society, shown towards built legacy, goes some way to explaining the constant finance deficit in this field. However future conditions may still entail even more additional costs, such as income loss, due to climate change, warfare, conservation science and non-use. Cost increase is due to the fact that outdoor climate has constantly caused mechanical deterioration, since it exposes all built structures to decay. Emissions from industrial production, such as fossil fuels have speeded up these processes. As early as the 1660's, degradation, such as discolouring, was observed on buildings in London due to the noxious air. Today the general assumption is that as a consequence of the forecasted global warming, there will be a rise in all historic building maintenance and conservation expenses. Expected enhancement of rainfall will probably accelerate weathering such as flaking of the stonework⁴¹, in which case any stonework would need to be replaced in order to regain its constructional stability. Indeed a majority of the built heritage properties are built out of natural stone that is of a sedimentary species of rock⁴², which is thus more porous since it is easier to shape. This fact makes stonework sites even more exposed to the predicted weathering⁴³. Warfare has always exposed built cultural heritage to threat of destruction and this originates from the political dimension; built heritage often has to reflect a national identity. Numerous examples of how foreign powers seized, trampled and destroy the historic properties illustrate how this was common practice in vanquished nations and in power struggles. Unfortunately, such behaviour is still a rule of thumb even in the most recent armed conflicts⁴⁴ alas generating immense expenditures for reconstruction. Moreover, 20th century internationalisation of building conservation by The Council of Europe 1949, ICCROM 1959 and ICOMOS 1965, has established a high ranking scientific preservation methodical approach and this is also adding to costs. Under the guidance of distinguished experts the traditional locally executed building maintenance has evolved into a technically advanced science.

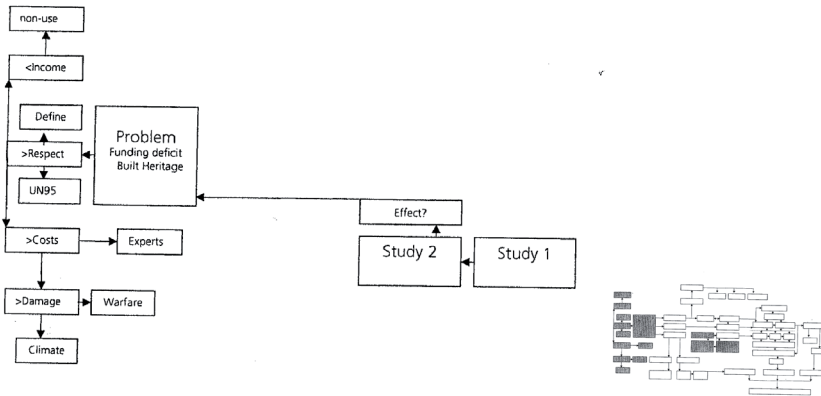

Figure 13.4 *The heritage economics' problem in actual building practice, was surveyed during Study 1 and Study 2. The study overview is to the right.*

Much income loss for proprietors is due to the fact that most significant built heritage is designated as historical landmarks. Sites have been protected so as not to be altered any further, which unavoidably would be the case should a building be put to any alternative use. Since the original use or purpose of a site is often no longer applicable, the defunct use constitutes a loss of original income, with expenses however continuing unabated. In fact the continuous growth of designated landmarks and protected legacy entails that the amount of non-use buildings has never before been so extensive. Funding demand is thus challenged to meet levels never before experienced. Of course it is possible to recoup some costs, for example by charging rent, when adapting a historic property, thus rendering new re-use of the property possible. However, the cultural heritage that once was listed, on the merits of its original appearance, implies a dilemma. If it is submitted to changes, it invariably involves alterations being carried out, alterations which by some professionals may be considered as intolerable, while they are by others considered as fully acceptable. Historic buildings generate higher maintenances costs than most ancient cultural items usually protected from use and placed in climate controlled conditions. A house's *raison d'être* will always be questioned and possible cost reductions sought. The logic of the argument claiming that properties erected for a practical use have to be frozen in time if they are to maintain their value recognition – is for this reason less obvious from a financial perspective. The three dimensional built heritage will for the same reason always take into account a variety of possible conservation objectives under the influence of time and the attitude of the individuals involved (see figure 13.4).

So to recap; the new economic role of built cultural heritage as assets which can contribute to third world countries' well-being and development, as well as today's widened definition of built legacy, explains the increase of built cultural heritage. The affluence of cultural assets only can be guaranteed by regular maintenance and requires that sufficient funding be readily available. All of which explains the present funding deficit of heritage economics. Future conditions such as income losses, climate change, warfare, conservation science and defunct or the non-use of sites, predict spiralling cost increase.

1.4 The solutions; demolition, new finance or cost reduction

In order to confront the growing funding demands outlined, new solutions need to be developed, if we are to alleviate the inevitable funding encumbrance. The case studies earlier presented revealed two of the most common answers to funding deficit; to decrease the number of heritage sites, as in the case of Maglarp, a church which was eliminated by demolition, or as with Allhelgona to augment new finance. One third option which often is used unintentionally, concerns the economizing of means; a more efficient use of available assets, as needs arise, due to budget restraints, but which can provide new solutions if planned with insight.

1.1.1 The demolition option

Heritage reduction implies that one set of standards provides a framework for identifying significant properties, from the less valuable ones. The immediate issue of concern is what frame of reference, or concept of value, is to be applied. History shows that value indications are time-bound which explains why demolitions already carried out hardly ever meet with the approval of generations to come. Examples to mention are the governmental policy of the 1930's which placed little significance on British 18th century country houses, due to new social structures in society⁴⁵. The 1960's city redevelopment policy in London and New York, permitting the Euston Arch⁴⁶ and Pennsylvania Station⁴⁷ to be pulled down, were greeted with just as much uproar, as did the equivalent vast destructions of historical town centres in Sweden at the time⁴⁸. Even less acceptance greets the devastation when monuments have been destroyed for purely ideological or religious reasons; such as palaces being blown up in former East Germany (see 141.1) until the 1980's, the destruction of the Twin Towers in 2000, and in 2001 of the statues at Bamyang.



141.1 *Schloss Putbus in the 1920's and 2009, picture of its remnants after the 1960's loss.*

The tearing down of a neglected and disrespected church like New Maglarp was allowed since the decision was regarded as the right one at the time⁴⁹. The three decades of non-use most likely mitigated the impact of the verdict and a distancing on the part of the local community arose, in spite of the church's obvious physically dominating features. The fact that Maglarp as a building once pushed the limits of the brickwork industry, the craftsmanship and the heights of architectural and engineering skills of its day, was long forgotten. Since its demolition was motivated by a lack of funds, the question is – whether that demolition outcome was actually a cost-effective solution – was it free of charge? It appears that the expense of carrying out a demolition, from an energy and financial waste perspective, turned out to be hardly insignificant. The local parish covered only some of the expenses due to directives set by the national property board⁵⁰ and others were paid for by the regional authorities⁵¹. Additional expenses were covered by the bishopric or by public means involving expenses for project planning, demolition, transport of bricks, cleaning and reuse⁵². Also the cost of ordering the three cost calculation to be made needs to be added, in 1992, 1999 and 2004, as well as all legal costs from the battles in court, between 1996 and 2005. The former New Maglarp Church landmark which used to be visible in the open fields from far away, on land and at sea, is gone, today replaced by a concrete sealed foundation providing a platform for occasional open air sermons, surrounded by tombstones⁵³.

In conclusion therefore, the three major reasons for excluding demolitions of built legacy as a solution for the funding deficit are; firstly, heritage destruction is irreversible and likely to be regretted in the future as proved in the past. Secondly it is inconsistent due to the energy waste, therefore incompatible with today's environmental policy since it is costly to destroy resilient constructions and; thirdly, demolition implies a loss in potential income resource.

1.4.2 The new finance option; acquiring and assuring funding

In the past, heritage funding for maintenance was always the owner's concern and only public built heritage could be funded, again by the private sector. Historically for instance, the subsidies available for the church refurbishment in Sweden, used to be the local parish's concern with inhabitants expected to offer their manual labour, or building materials, whenever required. For more extensive building ventures, in medieval times, the church raised money by increasing the purchase of letters of indulgence, and the church collect was also used, as late as until the 19th century. The Swedish neo-gothic expansion, from the 1860's however, liberated the locals from this manpower requirement. Instead, building entrepreneurs, together with the skilled craftsmen, were now paid in cash gathered through taxes, for their professional services. In the same way, would future maintenance work be publicly subsidised; a new funding solution which thereby distanced local inhabitants from involvement in maintenance work in their community and may explain the destiny of New Maglarp Church⁵⁴.

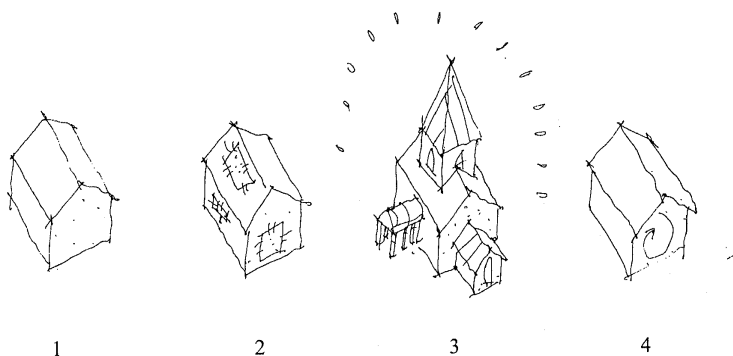

Figure 142.1 *The sequential sketches intend to illustrate how diverse heritage funding in the past can be said to have influenced the development of actual building conservation practice. The new constructed building (1). Until the 1850's building conservation can be described as patchwork measures whenever needed; the historical "layers"(2). Style purification (3) was feasible due to growing European wealth thanks to industrialism and new capitalists in society. Here the resurrection of the Cathedral of Cologne set the tone. The purification reconstructions sparked protests among intellectuals. National heritage boards were established and the heritage management was centralized (4), which might have "shut the door" to private financiers.*

Industrialisation is another factor which allowed the spreading of wealth in society to new social groups and to companies, rich from trade or industrial productions. Profits were thus invested in independent charities and company foundations, such as Rockefeller, Bosch or the Nobel Foundation⁵⁵. This social transformation provided society with additional financier groups, with new references to art and

history, than former ruling classes used to have. Expansion of cities by the end of the 19th century was funded on this new capital. Although building constructions of that time were technically advanced, their facades were still built in the style of older architecture, styles which expressed an outdated power. Historic palaces were the role models for establishing new positions in society⁵⁶. This new capital from the industrial wealth was most likely one of the major reasons for the uniformed development of the style purification movement in Europe⁵⁷. The emerging bright and modern cities now exposed the patchwork preserved medieval cathedrals in another light. For the scientifically grounded restoration of the Cathedral of Cologne for instance, expenditures up to 50% were covered by private capital⁵⁸. This church completion later became the trigger and inspiration for these new guidelines in building conservation. A large number of similar style purification projects followed it, which in Europe would have been impossible to launch without the new financial input from trade and industry. The funding for the European cathedral restorations was most likely induced by the eagerness among the new financiers to establish their social position in society. The style purification reconstructions however sparked protests initiated by intellectual classes by the end of the 19th century, which made public opinion grow strong against the remodelling of the national monuments, since after restoring these tended to end up looking far too sparkling and polished. Deprecating and at times often unjust condemnations of the architects alone were published; it was they who were considered responsible for the loss of historical authenticity⁵⁹. In the end, it was outrage which enabled heterogenic historical groups who favoured the pure preservation of built heritage⁶⁰ to unite, and the national heritage boards to be set up, for the first time. Here the elaborated legal framework of guidelines for protection of the built cultural heritage, in private and public ownership was thus established. This framework, it was decided, was to be enforced by the allocation of public subsidies. In a way centralization of the heritage management can be said to have shut the door to the possibility of private investors funding building conservations. To finance heritage thereby brought hardly anything in return, since the regulations set up by heritage authorities to follow, emphasised minimum intervention. Funding would not make headlines in the paper. Interestingly, nations outside Europe which never were influenced by the style purification did not develop strong public bodies setting guidelines for heritage protection. This may explain why, for instance in the U.S., private charity funding for heritage is still more common than in Europe.

The devastating human tragedies in the 20th century with the accompanying loss of cultural heritage subsequent to the two world wars, established the international cooperation of monument protection. Within ICOMOS and the Council of Europe, member states now began to discuss conservation issues,

from ideological positions to practical building measures. Here Eastern European nations like Poland or East Germany played a not insignificant role. During the Architectural Heritage year in 1975 it was ratified that all nations were obliged to find reliable heritage financial solutions⁶¹ and these were to be implemented according to the individual national policy; the funding deficit was regularly mentioned. Development of national and international finance support for built heritage thus had a random expansion during the 20th century, often initiated by sudden threats of destruction to built heritage caused by natural catastrophes, warfare or new constructions. Large sums of money were for instance allocated for building conservations, when former Soviet-controlled states like East Germany, Lithuania and Poland gained their independency in the 1990's. The issue of concern today is to distinguish national differences in the present heritage funding and if its organization has the capacity to meet the growing expenses. Recent case studies, for example, evaluating heritage funding in actual conservation projects (Skarin. Pålsson 2001) revealed noteworthy assumptions on likely unique effects in conservation work processes by the two major funding sources; public and private. These conjectures later on confirmed that public funding can imply adverse limitations (Skarin. Pålsson 2004).

Alternative funding structures for investment in new construction has been regularly developed over time. The global financial crisis in 2008 and its effect will be only properly understood with hindsight, but the demand for capital often brings new solutions along such as the recent development of the P2P banks⁶². When it comes to building conservation, successful attempts have been made for alternative funding solutions as well, but the matter is delicate and regulating norms might impinge on its efficiency. The heritage sector could in fact have a lot to gain from a more open-minded attitude toward new financial solutions. The building adaptation of Allhelgona church for example, would never have been possible to launch based on the grounds of governmental subsidies. The refurbishment was established primarily since it was feasible to fit into an EU funding program promoting growth in rural areas. This international contribution covered 1/3 of the expenses. The other 2/3 were split between the Swedish state (SFV) and the local municipality⁶³.

To argue that the quantity of built cultural heritage today has risen to heights, never before seen, merely refers to its appreciation. The physical buildings have remained unchanged but the interpretation of their values has transformed. The incentive for financiers to support cultural heritage will always rely on the recent evaluation of those historic buildings. The fact that heritage values applied at different times have neither been judged alike, nor interpreted the same by all individuals in society, is indisputable, as the Maglarp-Allhelgona case illustrates. This indicates that any abrupt changes in social structures might alter the inter-

pretation of essential values in built cultural heritage and so jeopardize a site's future existence. New national or political border lines or catastrophes causing social upheavals may re-evaluate heritage according to other policy guidelines or interpretations of history and lead to demolition. Only the built legacy with identifiable values, on the merits of an active liaison to history, will be spared and upkeep maintained. Legal protection acts and designation of historical landmarks have been introduced in Europe ever since the turn of the century 1900, to secure Europe's cultural values artificially. However in spite of all good intentions and vast inventories made, law enforcements and restrictions have not been capable of guaranteeing endurance for the building legacy, due to the lack of public finance, as the case of New Maglarp illustrated. The fact that historic properties still do exist, though appreciation of their values varies, implies that under certain conditions and external influence, the value of heritage actually increases. This rise in respect for heritage creates a motivation to act, as was the case with Allhelgona. The key to funding, in other words, lies in the way exterior conditions are capable of inducing funding augmentation. These facts have to be explored, as regards exactly what steps need to be taken for assuring future support, especially since that need for funding is growing.

In order to attain any guarantees henceforth for the built heritage finances, the capacity of financiers, their inducement to support and how to establish revolving funding – all need to be scrutinized. With improved knowledge of the procedures behind successful funding ventures, future financiers and funding forms might also come to light, especially since the need for heritage finance is incessant. For this reason the outcome; the preserved buildings, may never fail to encourage future financiers by visualizing a positive purpose for society and in this way, ensure good heritage economics. To understand therefore how to enhance present and assure future funding, first of all involves scrutinizing the mechanism behind the present funding, secondly the characteristics of today's financial sources and finally what the alternative investment forms might be with the potentials for resolving the dilemma of the future of heritage economics.

1.4.3 The cost reduction option; economizing funding

While demolition of historic buildings, as the solution to a lack of funds, is often ruled out by society due to today's environmental claims and when capital is inadequate, the economizing of project cost in conservation practice remains to be examined. With references to the complex budget planning, fixed price estimations for preservation works are hard to set. For instance initially hidden damages to a building may still emerge in the existing fabric at a later stage, even when thorough inventories have already been carried out. Similarly, assumptions

1.4.4 The topics of inquiry; to bridge the heritage economics

The growing number of built heritage today offers affluence in the form of cultural assets, but these assets can only be guaranteed on condition of them receiving regular upkeep and maintenance, which implies that sufficient funding for that purpose must be available. The registration of monuments worldwide confirms their rapid increase and mirrors an enhanced respect for historical heritage sites today. Two major aspects have contributed to the present conditions, firstly; the new fundamental role of cultural heritage as assets for economic development in the Third World. Secondly, the widened definition of the indispensable built heritage, observable in the vast progression of legal protection. These guidelines decide that a designated built heritage is protected so as not to be altered any further, which inevitably will occur when a legacy is adapted for a new utilization. As the original use of a historic site is often no longer relevant, non-use can entail revenue loss for the proprietor. Increasing level of reverence towards or sense of respect for, built legacy of the 21st century, thus explains current finance deficit, as does the issue of cost increase and income loss. Today's finance deficit in the heritage sector is also rising because of a general cost increase due to climate change, warfare and expertise or proficiency conservations. The concern involves the forecasted global warming which may lead to exceeding damages due to increasing rainfall. Exposure of historic buildings to destruction during warfare, originating from their political dimension, is hardly diminishing and finally preservations are becoming a technically advanced science in the hands of certified experts.

The Maglarp-Allhelgona cases reveal that highly valued historic buildings are better qualified for funding investments than ones which are lowly regarded. The exterior contextual circumstances, here called actions, surrounding built heritage, seem to be factors which determine the value of historic buildings, since these conditions are related to human perception. Fluctuating level of respect shown towards historic buildings implies then that a value loss is not necessarily caused by the physical characteristics of buildings, though this is often affirmed. Instead it is the exterior conditions which are influential and they establish a heritage image that will be perceived by individuals in society. These external conditions are probably capable of modification, all of which proves that values of built cultural heritage are likely to be adjustable artificially. This indicates that the capacity for augmenting heritage funding is most likely possible. Hence the gap between the heritage sector and the fiscal reality, here referred to as; heritage economics, may well be bridged.

Rapid increase of built cultural heritage sites worldwide, proves that our civilization, today more than ever, needs built heritage which no longer signifies national possessions, but heritage which is classed as global assets recognized as

providers of economic growth. Economists, since the 1990's⁶⁵, assigned as government advisors for legacy funding, have tackled assessments of heritage value within Culture Economics from the perspective of economy. This inquiry linking an architectural view on building conservation and economy, aspires to supplement these previous findings of the economists, with the built cultural heritage viewpoint and experiences from conservation practice.

The aim of this thesis is to propose a value stabilizing finance model based on actual building practice, in order to assist management of future heritage funding of the built cultural heritage. This study therefore outlines a heritage finance model based on the three major fields of concern; acquisition of funding, economizing funding and assuring the future funding (see figure 144.1).

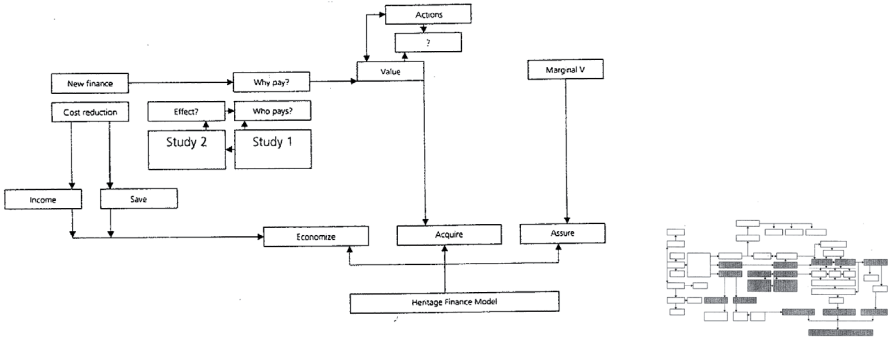

Figure 144.1 *The aim of this thesis; propose a value stabilizing finance model based on actual building practice including the acquisition, economizing and assuring of heritage funding. Study overview is to the right.*

1.5 The research questions defined

The major issue of concern is how to improve management in favour of future built heritage protection, in building conservation practice, endangered by the predicted funding inadequacy. This requires identifying the incentives and capacity among present financiers, initiating new groups and finding methods for cost reduction.

The overall question is:

How could economically sustainable finance models be structured to meet the challenge called forth by the expanding built heritage sector?

The limitation of this study focusing on the present as well as future enhancement of funding and cost reduction brings the following questions to light;

- *What are the inducements for heritage funding?*
- *What characterizes the present (private/public) finance sources of cultural heritage?*
- *What alternative funding groups may be encouraged for heritage support?*
- *Can building conservation practice be redistributed or rethought, in order to reduce costs?*

1.6 The research field

Studies in heritage economics are few since they perforce embrace two disciplines; building conservation and economics. Yet, the research field of *cultural economics* is much of relevance though these studies cover primarily the issue of culture value in general, from a theoretical stance and here economists are currently at the international research forefront. Corresponding research within *building economy*, on new production processes, has professional ties to building conservation, especially in practice and real estate evaluations (Björklund 2003), though less so in theory.

Science studies within building conservation, are above all dominated by three major fields of concern; history of applied building conservation, narratives on individual monuments and inquiries regarding the techniques of preserving ancient building material. Comprehensive studies (Jokilehto 1986)⁶⁶ fully illustrate how professionals, art, literature and social circumstance influenced the various conservation positions applied or disclose conceptual ideas of monuments (Barup & Edström 1990). Studies on the complexity which have determined decision-making in already completed conservation works⁶⁷, explain clearly the contextual settings in history for individual conservation decisions when these were made. However, such explanations will always be less valid for future strategic planning, due to the constant changes in developing societies. The internationalization of heritage conservation, established in the 20th century has contributed by encouraging wider research collaborations, as has been the case with technical disciplines of chemistry and physics⁶⁸, where computer science has recently gained a prominent position, such as by introducing interactive images of heritage sites.

In the 21st century it is time for the built cultural sector to get involved in heritage funding issues as well, since these provide the basics for all building protective measures and ensure the future of built cultural heritage. A recent Swedish study (Gustafsson 2009) points to this direction by penetrating funding of build-

ing conservations based on real life conditions for ensuring regional growth. This doctoral thesis thus wishes to make a contribution in this new research field, by the proposed heritage finance model on funding management planning to meet the increasing finance deficit in heritage economics. The finance discussed in this study concerns the additional heritage funding, which is vital for any building conservation work to commence, but it will never exclude a proprietor from his funding duty.

The following annotated research bibliography is subdivided according to the research questions set for this inquiry. The intention of the layout has been to disclose how these topics have advanced over time and where this dissertation might contribute.

What are the inducements for heritage funding?

Highly appreciated objects will always encourage purchase, or investment, since these indicate a sense of quality or *value*. Traded goods can, within a limited period of time, be compared with the universally used price level index; money. The intellectual values, then again judging for instance the quality of environments, or ancient items, always lacked the ability to be expressed in calculable figures, which has resulted in regrettable decisions being made over time. Studies aiming at converting the value of nature reserves, or historic buildings, into financially viable terms have nevertheless been designed. Cultural economics, which investigates the relation of culture to economic outcome, was established as a new theoretical approach in the 1970's⁶⁹. Culture in the broad sense such as art, built heritage or literature⁷⁰, was here to be measured or valued, by observing how ideas and the behaviours of individuals were spread. The initiators of culture economics were financial experts, assigned by public officials for policy issues concerning cultural heritage funding. Basing it on realistic models the economists, when attempting to test new assessment forms, realised that their approach to value diverged from the one applied by conservation experts. The interpretation of cultural value became consequently a major concern in the field of culture economics.

Whenever public funding is allocated, decisions need to be based on a policy that primarily is for the common good. For this reason evaluation methods were developed with the intention to prove the accuracy of financial investments. These early cultural economy studies were carried out in the US to stimulate future investments for project planning and maintenance of natural recourses. As early as 1949 Hotelling (Hotelling 1949) developed the *Travel Costs Method* (TCM) for the U.S. National Park Service (NPC) to augment investment, by qualifying the significance of National Parks. Assigned by NPC as a leading economist, Hotelling designed a method for converting the qualitative use value of

parks into financial viable terms. Further improvements (Clawson 1959)⁷¹ made it into a suitable valuation tool for measuring the benefits from recreation at natural sites. The Travel Costs Method was tested for economic valuation on heritage sites⁷², in a more recent Spanish study (Herrero and Sanz 2002). Today the TCM has progressed to the Contingent Valuation Methodology (CVM) for evaluating the demand of the non-market commodities in economical analyses⁷³, and has been applied in this study. The results from four case studies showed that one of the observed factors, *the willingness to pay* clearly created a hierarchy among the Spanish sites, but lacked precision⁷⁴. The outcome was only based on individual preferences, no matter significance of the site. In a next study (Herrero and Sanz 2002) the authors discuss in terms of *use-value* and *non-use value*⁷⁵. The non-use value⁷⁶; *option value*, *existence value* and *bequest value* were all excluded from the final analysis, due to the complexity of proper evaluation. The use value alone could be expressed in financial terms. Critics of the CMV⁷⁷ point at the risk that respondents might withhold true preferences, or that questions asked become too hypothetical⁷⁸. In spite of the obvious risk for biases, the method is frequently applied by cultural economists⁷⁹. The Journal of Cultural Economics, established in 1973, and recent research contributions (Throsby 2001; Peacock & Rizzo 2008, Hutter& Throsby 2008) are gaining acceptance within the built cultural heritage sector⁸⁰.

In spite of today's dominance of economists discussing cultural value, evaluations of cultural heritage were early explored into conservation practice (Wees 1976, Stein 1977, Alexander 1975 and Marston Fitch 1998). As a result of the oil crisis in 1973-1974, for instance a new value definition, called *residual value of energy*, was launched in the U.S. concerning its quantification in existing buildings, to prevent demolitions (Wees 1976)⁸¹. The restoration architect Wees, promoted recycling of built environment, in view of the persistent increasing building costs⁸² and the new energy saving requirements, at the time. The residual energy stored in old city centres Wees subdivided into three factors; time energy, natural- or human energy and kinetic energy⁸³. With the *Oregon Experiment* Christopher Alexander (Alexander 1975) criticised mass application of technology in settlements and favoured slow organic growth over times to come, since this is significant for good environments. A new building is never a "finished" thing but has a finite lifetime. However, it always has to be adaptable to changing uses and needs, in any traditional cultures and this is the way values will always remain⁸⁴.

The contribution by Richard Stein (Stein 1977) was to transform value of built heritage into a *unit of energy*, with the intention of avoiding the relative monetary value dimension. The uniting quantity index was the *embodied energy*, expressed in Btu/cubic foot. The theory was employed through an in- and out-

put model. The total amount of energy stored in building parts could be calculated, for instance energy consumption needed to produce one cubic foot of brick work⁸⁵. Energy saving aspects, such as those described, are more urgent today than ever and as regards considering heritage value in units of embodied energy, this might inspire new groups in society to preserve built heritage since it in fact contributes to a sustainable development of society. However, when claiming that the primary asset of historic building is its traditional building material, no guarantees can ever be set up that the building legacy will remain intact in situ. The re-use of its durable building materials has often been practiced in the past, as in the Maglarp case.

Cost-Benefit Analysis, CBA, is a frequently used analysis method to attain a theoretical, but assessable framework of what the possible gain⁸⁶ might be of an investment. The approach entails comparing a project from the standpoint of two possible situations; firstly with the funding allotment for a project and secondly without the support. To justify that a building conservation should be launched, all expected expenses are then to be subtracted from the total economical value of the heritage project. This is the sum of the *use* and the *non-use values*⁸⁷ and if these are to fit the application, these need consistently to be modified. The dilemma of the analysis method concerns how to make sure that all values have actually been included in the calculations and the fact that some values might be intrinsic⁸⁸. For example Ruijgrok says; “Works of art have a market but culture legacy has none and even lack a price tag” (Ruijgrok 2005). Value assessments are identical with *expert judgement*⁸⁹ and too distant from the explicability level. If one is to influence political decisions in demolition issues, economical interpretations are compulsory, he argues. This was why Ruijgrok applied the CBA method on an area in the Netherlands, which included both archaeological-, built heritage- and historical geographical features. By the use of three factors; housing comfort-, recreational- and bequest value, Ruijgrok finally could prove the economical benefits of preserving the heritage site. The benefits of conserving at this time exceed expenses. The welfare and housing comfort factors used in the study could both be discussed in monetary terms which were fundamental for the cost benefit analysis.

The Multiple criteria methods on the other hand, represents value assessment which differs from the ones previously described and here no monetary or numeral measurements are involved⁹⁰. Throsby (Throsby 2001) define for instance, the distinction between economic and cultural value by the fact that economic value will always be portrayed in fiscal terms. Culture value on the contrary is multidimensional since it lacks a standard unit⁹¹ and is thus described as a six levelled scale; aesthetic-, spiritual-, social- historical-, symbolic- and authenticity value, but more qualitative indicators are called for (Fusco Girard & Nijkamp

2010)⁹². In the cultural heritage sector definitions of cultural value were frequently discussed and traditionally had different expressions over time, but the multiple criteria methods have often been used and are further discussed in chapter 3.

A final approach to value registration in historic buildings is by registering feedback from test groups, as performed by (Coetier 2001) and (Ipekoglu 2004). In the first inquiry, lay people's evaluation of historic buildings was investigated by registering their value acceptance, but only by judging buildings from their exterior facades. The first study⁹³ revealed that the appreciation for historic buildings increased, the more decorative elements the monument had⁹⁴. The second investigation (Ipekoglu, B. 2004) used a gradation system to compute quantifiable architectural features, from facades to plans. These initially were organized by experts and the sites could be organized on a four levelled value scale. The methodological approach Ipekoglu claims, has potential for future estimations of building conservations costs. The fact that quantifiable exterior architectural features could have a positive impact on value, does hardly however guarantee that original features are automatically saved, since their maintenance signifies the most labour intensive and expensive matters in conservations, in relation to its size. Original decorative parts might thus be substituted with other corresponding elements, with an apparently genuine look in the layman's eye, but this will affect the authenticity of buildings negatively. These easy, accessible and obvious external value signs used to have a profound impact on built heritage's financial policy in Eastern Europe. Here the greater the number of historic layers exposed, even as "window fragments" on building facades, the better, since this stood in direct relation to the amount of public funding which was made available⁹⁵ (see front cover).

To motivate heritage funding it is fundamental to recognise that built heritage can actually signify values. The attempts made to transform the multiple criteria value of cultural heritage into computable figures, represent new assessment forms, which may primarily lead to improving value communication with new groups in society, as a common language. The numerically presented value significances, by using the TVM, CMV or the CBA methods, might promise a precision that is not actually available. Since all economical behaviour is motivated by each individual's notion of value⁹⁶, the main issue of concern is to develop a value converting tool with the ability to include or seize all the multiple criteria values used by and familiar to financiers of today and to analyse how these might be induced.

What characterizes the present private and public finance sources of cultural heritage?

The fact "Public funding for preservation becomes more and more scarce world wide"⁹⁷ was agreed among delegates attending the 9th General Assembly of

ICOMOS in Lausanne 1990 and who were also among the first to initiate the debate on Legislation and Finance in Europe by establishing a Committee. In April 1997 an International seminar in Weimar, Germany⁹⁸ discussed legislative structures for potential private sponsorship and participation for the future protection of built cultural heritage. Delegates from Canada and the U.S. presented a broader and more dynamic approach on private heritage funding solutions, than the European representatives did. The concluding resolution emphasized five issues of concern; that private financial sponsorship should be encouraged by governments, tax treatment modified to ease donations, trans-boarder cooperation facilitated, heritage organization supported and that new legal terms for building protections should be developed⁹⁹.

During the Dutch presidency of the European Union the conference “Privatization of culture: Limitations or Opportunities for Europe?”¹⁰⁰, was held with representatives from 11 countries¹⁰¹. The outcome of the discussions revealed both positive and negative arguments for privatization. The discussions concluded that; profit-making is the final goal of private cooperation and market-oriented strategies may transform heritage, from archaeological or building sites to museums, into profitable business, thus endangering the primary missions; to be educational, social and scientific¹⁰². Nevertheless, private sector financial contribution is a guarantee for pluralism, and thus a precondition of democracy¹⁰³. It is of vital importance to make a distinction when discussing privatization between ownership (to control) and efficiency (the cost per unit of delivery)¹⁰⁴. Throsby mentioned that “The culture can not isolate itself from the economical change” (.....).”occurring around the world “(..)”art and culture do not have to submit weekly to the forces”(..)”that may pose some threats to the cultural industry, but they may also provide new opportunities for growth”¹⁰⁵. Arguments in favour of privatization concluded that efficiency, quality, technological development might increase. Other advantages would be on the administrative level, since this favours democratization¹⁰⁶. Arguments against privatization were the potential cost increase, monopolization, quality or employment loss and the inability to secure the non-economical or cultural values¹⁰⁷.

Studies on the actual heritage funding are scarce, but the Pickard & Pickerill survey (Pickard & Pickerill 2002) calls for attention. The study investigates how the requirements of the Granada Convention¹⁰⁸ were met, which had been advocating that funding for built heritage was to be offered in all nations. The outline inventory of the available finance support in some European countries, fails to scrutinise actual effects of funding in practice. For this reason it becomes inadequate for judging efficiency of the support. The finance sources are just briefly mentioned and it fails to discuss the local outcome of the funding.

Inventories with a local approach, evaluating the actual consequences of funding in building conservation practice can be found in the Skarin. Pålsson study (2001). The purpose was to establish a legible model theory of the practical conservation process by which investigations of conservation projects in progress could be made, as basis for further studies on finance¹⁰⁹. A more recent study, Skarin Pålsson (2004) is of privately and publicly funded projects as an inventory with interviews of actors in 12 building conservation in six countries¹¹⁰. Both studies have provided basics for this doctorate thesis.

Innovative financing in Italy, Trupiano (Trupiano 2005)¹¹¹, has provided new opportunities for solving financing of built heritage, which traditionally is shared public funds¹¹². The main characteristics of funding, according Trupiano, are *origin of source* and *nature of source*. The origins of source are either public or private. The natures of public subsidies are direct or indirect, but market revenues, or endowment funds, distinguish private means. Direct public subsidies means a lump-sum not connected to prices, production factors or products. The term indirect public subsidies are all forms of tax breaks or deductions. Two forms for distribution are discussed in the study; the public oriented and the market oriented distribution¹¹³. The *Italian corporatisation* is an organisational model of funding where private and public sectors become integrated. It has managed to enhance the role of individuals at local level, as businesses. Tax incentives have promoted donations and legislative alterations since 1993 due to the Ronchey Law¹¹⁴, which stimulated corporatisation. This is the way private enterprises today operate in non-cultural services¹¹⁵. Donations from the private sector need encouragements, for example as permitting deductions, such as *gifts* from the tax base. The recipient also needs to be active in providing offerings as discounts; subscription, invitation to events or free guided tours to attracts more future funds “so giving the donor a sense of belonging “(to a)”a selected group”¹¹⁶. Private donations, either corporate or personal, are more frequent in the U.S. than in Europe, due to tax-exemption or tradition says Trupiano¹¹⁷.

International agreements during the last three decades have affirmed the national obligation of subsidizing built heritage, and resent inquiries (Pickard & Pickerill 2002) verify that new finance solutions for built heritage have developed. To judge these improved effects in praxis, with solution or finances sources that actually provide the best outcome, individual case studies are thus necessary. Public and private funding may be allocated in a numbers of ways both to support private foundations, advocacy groups or as a regulating tool for heritage authorities. Field studies from practice (Skarin. Pålsson 2001, 2004) in this way provide a most essential contribution in order to understand funding structures and sustainability, if to be of guidance for future funding encouragements.

What alternative funding forms may be encouraged to heritage support?

Although Michael Klugers article¹¹⁸ on hospital renovations 1984, refers to a financial situation relevant more than two decades ago, the form suggested is a new approach to attaining finance for building maintenance. The author discusses pros and cons toward long-term contra short-term financing¹¹⁹. Kluger argues in favour of the more flexible and money saving short-term financing. "Financing a renovation is identical to financing the construction of a new facility"¹²⁰ since long-term, fixed rate debt still is the most frequent funding solutions and "the goal is to obtain financing for the construction at the lowest possible cost"¹²¹. The hospital board has to choose between a permanent or temporary financial solution for the renovation. In practice when interest rates are low, the board issues fixed-rates revenue bonds, but when rates are high other alternatives need to be tested, such as short-term securities that have to be refinanced until the interest rate declines. Since these innovative short-term alternative financing techniques have come about due to tax-exemption on commercial papers (T-ECP) the hospital can raise interim funds for the project and especially T-ECP's were shown to generate much income¹²². The short-term financial solutions are backed by bank letters of credit since they are of a more risky character¹²³. The author explains that short-term solutions "generate substantial debt service savings"¹²⁴.

To initiate external investments by issuing bonds as an option to generate capital, as described, is already practised internationally as venture capital for company investments or new constructions¹²⁵. However, in the U.S. this credit funding has been applied in traditional building preservation projects since the 1980's, for example at the South Street seaport¹²⁶. To purchase bonds or commercial papers does not entail any profound knowledge of how hospitals are managed or what historical layers to conserve in a historical monument, since the purchase by the investor, is only initiated to bring about a finance value growth. This entails that investment from a neutral, or passive agent, might even be good for built heritage projects. Especially if considering the large number of professionals who are already involved¹²⁷. One reason why the European built cultural heritage sector has not advanced into the investment market as practiced already for other ventures, such as new constructions, innovative businesses or alternative energy projects, might be linked to the centralization of heritage authorities for dealing with the heritage issues which were established around 1900 in many European nations.

Can building conservation be redeveloped in practice to reduce costs?

Since the practical conservation process can primarily be analysed or illustrated through the time consuming observations and interviews, with the parties in-

volved, little has been published¹²⁸ regarding this, until the study presented here. Nevertheless, the Polish Conservation Company; Przedsiębiorstwo Państwowe Pracownie Konserwacji Zabytków, more renowned under the abbreviation of PP PKZ, used to be one of the few exceptions. This state firm regularly employed detailed research analyses on building conservation efficiency. The company was established in 1955 and from its 15 workshops, spread out in Poland, they managed national as well as international building conservation projects. Each unit had their individual areas of conservation competence¹²⁹, from historic constructions to interior settings. For more than four decades they were active members of ICOMOS (ICCROM) until the PP PKZ organization was disbanded in 1990. This efficient cultural heritage industry of PP PKZ has been criticized at times for frequent use of modern materials¹³⁰, but their craftsmanship skills are today much appreciated, especially in New York City where new businesses have been set-up by former PKZ employees¹³¹.

In order to illustrate how funding might be economized it is essential to establish the item of expenditures, or separate costs, based on case studies of building conservation projects and how these might be distributed in practice, to realize any funding reductions.

“So geschah es, dass unser ..Land von seinem schönsten Schmuck so unendlich viel verlor, was wir bedauern müssen” “..so werden wir in kurzer Zeit unheimlich nackt und kahl, wie eine neue Kolonie in einem früher nicht bewohnten Land dastehen” (Karl Friedrich Schinkel 1815)¹³²

1.7 Research study overview; justification, contribution, limitation and chronology

1.7.1 Justification, contribution, limitation

The justification of this doctoral thesis involves the descriptive proposal for awareness growth of how to deal with the urgent and increasing funding deficit in heritage economics. Today this is particularly imperative, as tangible built heritage is officially recognized for its explicit role for regional economic development (WCCD 1995, Gustafsson 2009, Mellander 2008). Operational heritage finance models are lacking and since this study is based on empirical case studies of heritage economics; evaluating funding issues in reality, the hope is for it to be valid for future strategic planning. The inquiry is multidisciplinary with an approach involving studies of economy, cultural economics, sociology, architecture and building conservation.

The suggested contribution of this doctoral thesis is the exploratory analysis of the mechanisms behind heritage funding with accelerators, hence introducing new terminology into building conservation instigated by the idiom of economics. Crossing disciplines could improve contact between accountable stakeholders, thus aspiring to ease future policy decisions and future strategic planning of heritage funding. This analysis involved scrutinizing previously less explored fields such as: outlining the development of value concepts used for assessing built legacy and setting up, but also testing, a conceptual value tool. Current and alternative financier groups' characteristics were established by means of their value preferences and the listing of funding forms revealed variety of forms to promote, other than cash flow.

The limitations of this inquiry made it necessary to exclude analysing the European Commission's Structural Funds and Framework programs in detail, though their significance as financier has risen lately. It is apparent that this new international heritage funding device has the capacity to give the heritage sector a more prominent role and engage more parties in preservation issues, especially in nations such as Sweden, with limited private funding, as exemplified by the Allhelgona case. Furthermore, in the heritage economic analyses, of Study 1-2, limitations according to number of conservation projects and in countries were unavoidable, due to the time consumption for personal visits at building sites and the encounters with participants. Nevertheless these trips proved that the projects did signify a sufficiently wide spectrum, which was essential for the qualitative approach.

1.7.2 Chronology

The positive financial flow in the 1990's to the heritage sector and building conservations, inspired initiating this research study, Study 1 in 1997. As a result 15 case studies of building conservation projects in progress were selected from Western Europe, as well as the former East Europe, which became accessible after 1989. The building conservations in Lithuania, Latvia and Poland received heritage funding from western neighbouring countries. These sites were selected on behalf of the previous historical ties to their neighbours, since the sites stimulated shared memories of former national possessions for the benefactors. The temporary financial decline, in some western nations, such as Denmark and Sweden, also promoted domestic building conservations, at the time, by enhanced funding for heritage sites. The nations on the Baltic Sea, such as Finland, Lithuania, Latvia, Poland, Germany, Denmark and Sweden, have related architectural legacy, which has been established through trade and this fact alleviated a comparison of the conservation works, regarding the buildings' physical structures.

In Study 1, empirical field observations of progressing building conservations on specified building categories per nation were selected; a manor house, church and vernacular building. Project time limitation (1990-2000) as well distinguished the selection of cases further. The practical approach, based on interviews in five countries, required a strictly systematized analysis in theory. This was attained by defining the conservation process as four separated but interacting factors; Value, Team, Finance and Legal framework. Financial structures in five nations and their process effects in the case studies could thereby be analysed, summarized and finally illustrated in a special designed graphical matrix¹³³. This first study was presented as a Licentiate Exam in December 2000.

In 2004 the outcome of Study 1 was re-developed further and hypotheses involving financiers' limitations or preferences were verified. By means of an ideal cast list, outlining the different actor's involvement, 12 preservation projects this time were analysed, funded either by public or private means. Other than directing the funding sources in the project selections, the case studies were to be in progress during 2000-2004. The six countries which were analysed should be represented by two case studies, each according to the highest and the lowest financed at the time. National heritage authorities provided the selection of sites and this was a way to ensure the conservations had more national characteristics, since the choices most likely were guided by them, to show the "better" examples. Data achieved from the interviews was analysed according to the previous study, but this time methodological improvements made the study less time consuming. The outcome of the study was initially a report, but later presented as a paper at the International Expert Seminar on the economics of heritage preservation in Helsinki, Finland 2005.

During 2008-2010, which represents this thesis, the data attained from the building conservation practice, Study 1 and Study 2, concerning heritage economics, with facts on heritage funding in actual practise, provided the basis for the next theoretical analyses. With the intention of managing the finance deficit in heritage economics by increasing funding, a heritage finance model was proposed, concerning the acquisition, economizing and assuring of heritage funding. The findings of all the studies (Steps 1-5) in the final chapter, once more could be compared to and tested against building conservations from practice. The outcome of the studies, for this reason initially assumed the heritage finance model, therefore could be improved (see figure 172.1).

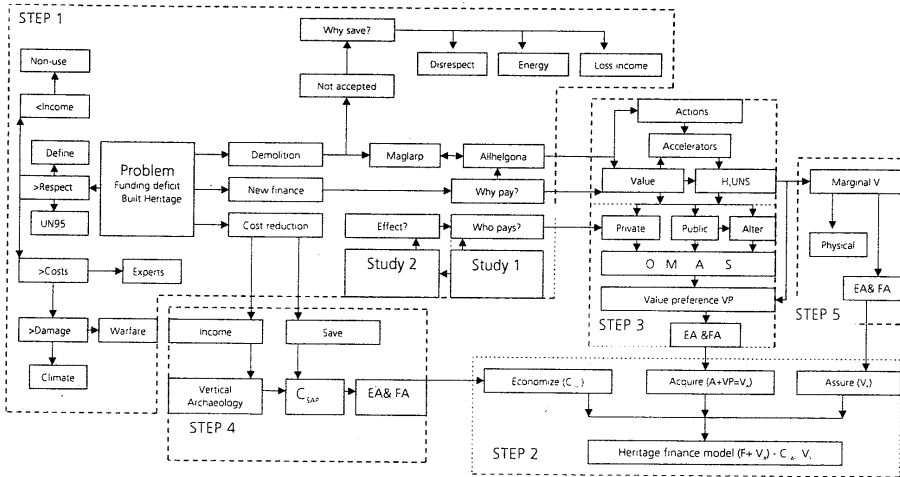

Figure 172.1 The strategy and research design of the thesis.

The strategy and research design of this inquiry involves five steps;

- Step 1: Analysing heritage economics in reality (Study 1-2, appendix 4)
- Step 2: Assuming a value-stabilizing heritage finance model (chapter 2)
- Step 3: Acquiring funding (chapter 3-6)
- Step 4: Economizing funding (chapter 7)
- Step 5: Assuring funding (chapter 7)

1.8 Definitions

Accelerator is a perception capacity of an interpreter or spectator, such as a financier, to see specific values in built cultural heritage. The values he first of all observes are those he favours i.e. the financier's value preference.

Actions the external conditions in the contextual setting of built heritage, which depict built legacy for man, hence they direct or decide how it will be perceived by society.

Adaptation or building adaptation is equivalent to Marston Fitch (1998)¹³⁴ definition of "adaptive use". Changes made in the built fabric according to tenants' requirements, which is the only economical way to save old buildings.

Built cultural heritage (historic buildings, the built legacy, heritage sites) refers to all existing architectural constructions composed by man over time, with or without a landmark listing status.

Conservation is equal to Marston Fitch (1998) definition; physical interventions in the actual constructions to ensure its continued structural integrity.

Financiers or financiers are all groups in society who contribute with funding forms in favour for the protection of the built cultural heritage

Funding forms can be either out of monetary or human capital and have here been classified as: Direct funding (DF), Indirect funding (IF), Replacement funding (RF), Credit funding (CF) or Transmitted funding (TF).

H_3 *UNSC concept* the value scale used in the study as an instrument or benchmark to study the mechanisms of funding among private, public and alternative financier

H_3 , the historical value expression includes all three historical value forms; qualitative (H_1), knowledge (H_2) and quantitative (H_3). H_3 , H_2 , or H_1 here the historical values are individually expressed.

Mechanism of funding describes the theory behind the inducement, that is the acquisition of funding. It explains the acquiring of heritage funding and is expressed; action-accelerator-value.

Heritage economics is like a sub-group to cultural economics, but is only viable to heritage, i.e. the fiscal requirement of for instance built heritage and the available means.

Intentional distribution of building phases is re-distribution or re-scheduling of the order in which building conservation work is carried out. These could be completed at different times in order to reach set goals, such as publicity to stimulate an injection of finance.

Multiple criteria value concept describes the multidimensional culture value which is lacking a standard unit and excludes all monetary or numeral measurements.

NPO is a Non-Profit-Organisation. In the study the abbreviation defines a category of financier of the built heritage which is totally self-sufficient.

OMAS format is a registering structure of financiers used in this study; Origin of the benefactors' funding, Methods used, their Accelerators and Sustainability of funding.

Paybacks establish a sense of guarantee that outcome of a funding behaviour or commitment is, or can be prosperous and this conviction is what primarily makes the value of the built heritage stable.

Preservation is equal to Marston Fitch (1998) definition; the maintenance of the artefact in the same physical condition, without additions or subtractions made, but when practiced then only in a cosmetically unobtrusive manner.

Public funding is all governmental financial recourses matching and set up by political decision nationally in a finance budget.

Private funding; includes all bequests from the non-governmental sector and excludes the indirect funding.

Restoration is equal to Marston Fitch (1998) definition; a process of returning the building to the physical condition in which it would have been at some previous point in time.

Value (V) refers to value concept of multiple criteria such as suggested by Fielden, Riegle or the H₃UNS concept.

Value preference (VP) is the benefactors and financiers own selection of value units (V) and intellectual goals for an action such as an economic behaviour.

Value level activating to funding (V_A) describe the level required to induce economic behaviours, see funding forms.

Marginal value (V_B) describes the future gain and output of the preserved building, vital to assure future funding.

Vertical archaeology refers to the different tiers of layers of time of historic buildings. The skills and knowledge gathered during the conservation work can be spread to many via guided tours or lectures. While this understanding is affecting historic quality and knowledge values (H₁H₂), the promotion generates income.

1.9 Disposition of the thesis

In the first chapter 1: *Introduction*, the proposal of the dissertation is described by outlining the present finance deficit of heritage economics. Based on these analyses the research questions are defined and presented. Relevant studies from the research field are examined in the annotated research bibliography and these are structured consistent with the research questions set for the study.

Chapter 2: *Methodological approach*, initially describes the system of inquiry, strategies and tactics applied in the study, which are structured as *Steps* from 1-5. Step 1, which is exploring today's heritage economics, represents previous studies and is for this reason printed separately. The conclusion drawn from these findings made for this final thesis, are thus presented as an Appendix. A detailed description of the modus operandi concerning *Step 2*, involving the finance model theory, is then presented to elucidate the issues of interest and the dilemma to solve in the next chapters.

The chapter 3: *Value*, begins with an overview of the use of value expressions in general and for culture heritage, in practice and in theory. Based on an earlier value concept, which was refined, the H₃UNS concept could thus be established. The chapter continues to discuss and analyse the first phase of Step 3, on funding acquisition, in order to seek answers to the question; *What are the inducements for heritage funding?* The value concept suggested is further tested to equivalent value structures and finally in test groups.

Chapter number 4: *Acquiring private funding* (Step 3), investigates a large group of the most active private groups involved in heritage funding globally. To establish their nature and mechanism of funding, the OMAS format has been applied. The question to be answered here is; *What characterize the present private finance sources of cultural heritage?*

Chapter 5: *Acquiring public funding* (Step 3), begins with defining the parties engaged in the public heritage funding. Additionally the study intends to explain already explored differences between national groups. Once more the OMAS format has been applied which enabled the revelation of new findings and answers to the question: *What characterize the present public finance sources of cultural heritage?* The sustainability of public heritage funding has been investigated through a case study of two national property boards' heritage economics.

In chapter 6: *Acquiring alternative funding* (Step 3), three new financier parties are discerned, though some of them are already funding cultural heritage, and this support is only viable for individual nations. With the use of the OMAS format the research question to answer was: *What alternative funding forms may be encouraged to heritage support?*

In chapter 7 the other two issues of the finance model *Economizing and Assuring funding* (Step 4-5), are discussed. At first, a theory of how an intentional distribution of building phases may economize heritage funding is outlined and then analysed in three current conservation projects. The question to discuss was: *Can building conservation practice be redistributed to reduce costs?* Secondly, the subject of: *How an economically sustainable finance model be structured*" entails securing a recurrent heritage funding. This pinpoints the vital topic that buildings have to guarantee a future gain, which both involves preventing damages to original structures but also the built legacy's capacity henceforth, for nourishing the mechanisms of funding.

Chapter 8: *A Finance model for the built cultural heritage* begins with a summary of the results attained in the earlier chapters. Based on these findings the notion of value then is scrutinized, where the traditional value focus is set aside in favour of emphasising the process of human behaviour, namely the vital emotional and financial accelerators. The argument then is explained and confirmed by building conservation examples from actual practice. Additionally the Swedish perspective of heritage funding reveals some new findings referring to the negative effects of weak accelerators, thus explaining some of the Swedish inadequacies in heritage economics. The chapter ends by suggesting further testing of the heritage finance model, for a possible future use, due to the recognition of finance support of building conservations in developing economies.

2.0 Publications

2.1 Papers and articles presented or published during the research studies

Ingela Pålsson. Skarin "Models for an objective evaluation of Restorations" Proc. Conference *Documentation and Conservation of Wooden Towns*, NorFa, Tallinn September 1999.

Ingela Pålsson. Skarin (2001) "Building Preservation around the Baltic Sea, a study of the work process based on case studies from Lithuania, Poland, Germany, Denmark and Sweden" licentiate degree. Original title "Byggnadsvård kring Östersjön – en studie av arbetsprocesser med fallstudier från Litauen, Polen, Tyskland, Danmark och Sverige. Licentiat examen.

Ingela Pålsson. Skarin "A comparative study of the financial support in twelve restoration projects from Denmark, Germany, Great Britain, Norway, Finland and Sweden", Proc. Conference *International expert seminar on the economics of heritage preservation*, Helsinki 12-13 of December, 2005.

Ingela Pålsson. Skarin "New Finance models for the Built Cultural Heritage", Proc. Conference *CHRESP The 8th European Conference on Research for Protection, Conservation and Enhancement of Cultural Heritage*, Ljubljana 10-12 of November 2008.

2.2 Additional relevant articles and reports

Ingela Pålsson. Skarin, "Byggnadsliggare Alriksgården". Dokumentationsuppdrag inom Tradition och Byggproduktion, Riksantikvarieämbetet. Lund 1996.

Ingela Pålsson. Skarin, "Byggnadsliggare Blekingegården", Dokumentationsuppdrag inom Tradition och Byggproduktion, Riksantikvarieämbetet . Lund 1996.

Ingela Pålsson. Skarin "Byggnadsliggare", Byggnadsforskning 5/1997.

Ingela Pålsson. Skarin "Byggnadsvårdssamarbete mellan Polen och Sverige efter Hallandsmodellen". Kvalitativ metod. Lund 1998.

Ingela Pålsson. Skarin "Eternit", Byggnadskultur 2/1998

Ingela Pålsson. Skarin "Kulturvård finansieras privat i forna DDR", Byggnadskultur 4/2004.

Notes chapter 1

1. Quotation is from Throsby (2001, p. 19).
2. Maglarp was de-Christianized prior demolition 060520, Sjögren (2009, interview).
3. All Swedish churches built before 1940 are legally protected, according to Cultural heritage Law; Chapter 4, Kulturminneslagen, KML (1991, p. 18) and Schwanborg (2002, p. 13).
4. Länsstyrelsen is translated to the County Administration.
5. Industrialism and innovative achievements in agriculture, see Svala (1998, p. 9). See also Style purification movement, note 59.
6. Over 30% of the early medieval churches were demolished during the 19th century, see Fernlund (1982, p. 7).
7. The national curator Carl Curman wrote to the Maglarp parish and reminded them of their responsibility to maintain the Old Maglarp Church, as follows; "You have to start up a collection of money in the region and commission a skilled builder who can plan and carry out the necessary works needed for the safety of the church", Curman, C. (1924).
8. From 1870 to 1900 and 137 churches during the period of 1840 to 1910, see Antell (1991, p. 47f).
9. Modern techniques, such as the tracery in windows were made out of concrete and steel reinforcements or concrete joints. H. Boklund from Malmö was the architect for New Maglarp Church and the master builder P. Pettersson from Mellan-Grevie. The construction costs for the church in 1909 were 71 950 SEK, Trelleborgs Allehanda (1909).
10. The last sermon was celebrated in 1976, Regeringsrättens dom (2005, p. 2).
11. The last maintenance works ever were carried out in 1968, Hegelund & Marsvik Architects (1992).
12. Hegelund & Marsvik Architects calculated with 1 370 000 SEK for the interior and 1 870 000 SEK for the exterior repair works in 920919, in total 3 240 000 SEK, Hegelund & Marsvik (1992).
13. Riksantikvariämbetet Yttrande (2007, p. 3), Statement from Swedish National Heritage Board.
14. Sjögren, B. (1996) informed the regional curator Karin Bunte.
15. Hegelund & Marsvik Architects calculated alternative 1 to be 4 533 750 and alternative 2 to 5 553 750 SEK for repair works on Maglarp.
16. The cost estimation made by Architect H. Ponnert was 31,2 million SEK, Regeringsrättens dom (2005, p. 5). The conservation costs had increase by 27, 9 million SEK in 12 years and only during the last five years with more than 25 million SEK. However, no additional damages had occurred such as fire. The roof was still intact, but of some minor leaks, and since it was un-insulated it was well ventilated.
17. Regeringsrätten is translated as the Supreme Court.
18. Adaptation of the church to a monastery, a museum or for youth activities, Sjögren, B. (2009, interview).
19. The scientist lived and worked on the island Ven for two decades 1560-70's.
20. Stadskyrka is here translated as Public church.
21. Its size increase from 25 to 200 m² and the number of visitors from 8000 to 40 000, Nyström (2009 interview).
22. Failure in heating system was discovered in 1990, ibid (2009, interview).
23. One Swedish Crown, Krona, ibid (2009 interview).
24. The inventories' movables such as 300 meters of church benches were to be stored in case of a future sacred re-use of Allhelgona. "It is easy for the authorities to say since they do not have to pay for these costs", quotation from, Silén (2009, interview).
25. Church recycling can under certain circumstances be approved, but may never lead to any losses of its sacred inventories, if ever a church adaptation of will be accepted. The local parish is always held responsible even if the church is purchased, RAÄ (2006, p. 4).

Authors comment; The legal framework leaves the parish with only a few options, such as to apply for church demolition. This unfortunately is more often discussed in parishes today.

When the parish of Skeppsholmskyrkan in Stockholm applied for the church to be used for exhibitions, since it is next door neighbour to larger museums on Skeppsholmen, this request was turned down. However, the heritage authorities could approve to a church re-use for a concerts or rehearsal room use for musicians. In this case the interior would remain unchanged, Schwanborg (2009, interview).

26. The costs were split up accordingly; 37% for conservation of church constructions, 37% adaptation to museum and 46% other investment made, Nyström (2009, interview).
27. The costs for urgent conservation works were 6 million SEK for Allhelgona, prior adaptation on the interior, Nyström (2009 interview). This amount corresponded to the estimated conservation costs made for Maglarp in 1999, see note 15.
28. The Wagon museum suggested was originally established in another region, which was situated at a 700 km distance from the church, Sjögren, (2009, interview).
29. Eight heritage sites were inscribed in 1978, which were cultural and mixed sites and in 2009 the number has risen to 714, World Heritage List (2009, Web).
30. The State Parties are always responsible for seeing that all maintenance and conservation works are in accordance to the ICOMOS agreements, Valanchon, N. (2008, interview).
31. In the period from 1978-2009 with 62 sites during 1978-1988, 45 from 1988 to 1998 and 33 cultural sites during 1999 to 2009, World Heritage List (2009, Web).
32. In 1996 it had 57 countries and in 2009 the number had risen to 99. From the 544 totally listed sites, half of them, 79 countries, have received WMF grants, since the Watch list continuously is updated with new nations, WMF and WMW (2009, Web).
33. The number of listed buildings in Sweden is less, only 2011 sites in total, especially in comparison to the German medieval city of Stralsund which has more than 800 sites only within its medieval city walls, Wienands 1998.
34. An increase from 1311 to 2011 listed sites in 2004. See RAÄ (2005, p. 34).
35. During the period 2001-2004, the number increases by 288 sites, *ibid* (2005, p. 34).
36. The UN World Commission on Culture and Development (WCCD), 1995, a report involving Economical-, human- and cultural development. See Throsby (2001, p. 10, 66-71) and (WCCD, 1995, pp.24-5 & 206-7).
37. See Throsby (2001, p. xiii).
38. See Throsby (2001, p. 71).
39. Council of Europe; "Framework convention on the Values of cultural heritage for Society".
40. The other essential triggers such as access and use were promoted during heritage year 1975.
41. The noxious air from the 17th century. Honeycomb weathering refers to when water penetration will activate the damaging salt crystallizations of sodium chloride or calcium sulphate, in pores with material loss, see Inkpen (2004).
42. Sandstone, marble or lime stone for instance.
43. Acid rain and pollutions is already a major problem today in capitals, see Inkpen (2004).
44. Warfare in Irak, Afghanistan or former Yugoslavia but not as devastating as during the 1st and the 2nd WW's.
45. Five percent were demolished between the two world wars, see Hunter (1996, p. 99).
46. London in 1961.
47. New York in 1963.
48. During 1960-70 more than 40% of the historic city centres were demolished, see Johansson (1997, p. 11).
49. The expansion of a nearby planned residential districts; Stavstensudde, could have concerned new families and voters more than the inaccessible neo-gothic temple.

50. Concerning for instance the church interior movables which required a proper storing, they were instead sold, Sjögren, (2009, interview).
51. The building documentation at the photogrammetric measurement for the public archive, at County Administration office, Malmö.
52. Two tons of brick work were recycled and the costs for cleaning the bricks from mortar is about 8 SEK per stone, Agnesson (2009, interview). The price for a new produced stone is around 5 SEK.
53. The suggested new adaptation uses for Maglarp were all lacking the local tie and the present concrete platform has scarcely been used for open air sermons, Krigström (2009, interview).
54. Social upheavals at the turn of the century 1900 such as in the agricultural sector made it difficult for some families to keep their estates and some changed ownership, but the need for funding still remained.
55. See Hondius (1997, p. 19).
56. The simultaneous growth of the architectural professionals, educated by copying the historical styles in architecture, brought the competence required, see Svedberg (1982, p. 117ff).
57. See illustrations or photographs, Dvorak (1916).
58. ”Etwa die Hälfte des Geldes kam aus der preußischen Staatskasse, die andere Hälfte brachte der Zentral-Dombau-Verein auf, in dem viele engagierte Kölner Bürger sich zusammengeschlossen hatten”, Kölner Dom (2008, Web).
59. Monuments, such as the Cathedral in Lund, had suffered from severe constructional damages caused by a fire in the 16th century that the 19th century engineering skills and modern building methods could solve. The exterior support construction of buttresses, added over the centuries, could be removed, but probably at the expense of reconstructing the interior vaults. See Zettervall and Callmer (1981,p. 53) ”Jag fick Domkyrkorådets uppdrag, att inkomma med en arbetsplan”...”af nöden att reparera på den gamla illa medfarna Domkyrkan and Zettervall and Callmer (1981,p.130) p. 130 ”... , men urgamla hantverkares dumheter”...”har stundom fått stryka, ty att respektera dumheter hur gamla och murkna den än äro bliver ju alltid en dumhet..” .
60. Professionals such as archaeologists or art historians. In Sweden for instance a majority of the national curators early on, like Oscar Montelius and Hans Hildebrand, have been archaeologists, see Wetterberg (1992, p. 67ff).
61. European Charter of the Architectural Heritage 1975, The Declaration of Amsterdam 1975, Declaration of Tlaxcala 1982, Faro 2005 and Xi’an declaration 2005, see chapter 3, px.
62. P2P refers to *Person to person* banks, which accept loans to less credit worthy groups, but still with a low costs since no middle men are required, see Anderberg (2009).
63. The program set up by the European Union was directed for funding ventures in scares-populated areas, thus approved 33% of the expenses and municipality together with state supplied the other 66%, Nyström (2009, interview).
64. The non-existing and inadequate foundation constructions according to building heights, which was the case for the Jacobi Church, see Skarin Pålsson (2001, p. 128ff). This was as well the predicament for Cathedral of York, Feilden (1994, p. 285ff).
65. See Peacock and Rizzo 2008, p. viii ff. Studies in heritage economics are however less frequent, to the author’s knowledge.
66. See as well (Kåring 1992, Denslagen 1994 and Hunter 1996).
67. Marston. Fich 1982, Dianslagen 1994 or Kåring 1992.
68. Non-invasive analysing methods see Hellström 2008.
69. Scitovsky (1976 p. 3), Hutter, M. & Throsby, D. (2008) and the foundation of Journal of Cultural Economics in 1973, Journal of Cultural Economics (2009, Web).

70. Others areas such as religion, literature, social-norms, -capital, -network, see Culture economics (2009, Web).
71. See TCM, (2009 Webb).
72. This involved a village with historic buildings and a museum, see Herrero & Sanz (2002).
73. See Throsby (2001, p. 82).
74. “..tourist frequency constitutes as an indicator” , Herrero & Sanz (2002).
75. Use value refers to utilize of goods and the non-use is more of a qualitative approach, Ibid (2002).
76. The *option value*; the value or potentials of a person wanting to visit an historical site, *existence value*; the value a person estimate, like an appreciation for that the option exists to visit the site, though he does not intend to make a visit. Finally the *bequest value*; the quality that the building remains for future generations to benefit from, Ibid (2002). This is an ideal of British National Trust.
77. Contingent Valuation Methodology.
78. See Throsby (2001, p. 82 ff).
79. More than 140 papers on CMV method have been published since 2000. The method refers to hypothetical studies which is why it perhaps is better applied for the analytical techniques and not for policy debates, Peacock and Rizzo (2008, p. 126).
80. Discussed at the Conference CHRESP The 8th European Conference on Research for Protection, Conservation and Enhancement of Cultural Heritage, Ljubljana 10-12 November 2008.
81. See Weese (1976, p. 15), Marston Fitch (1998, p. 32).
82. The cost for new construction had doubled in five years time, *ibid* (1976, p. 15).
83. That is; individual decisions of time, material of artisanship, construction fuel required, *ibid* (1976, p. 15).
84. Alexander (1975, pp.68ff), Marston Fitch (1998, p. 35).
85. *Ibid* (1975, pp.68ff).
86. The Economical term is; opportunity cost, see Peacock & Rizzo (2008, p. 157).
87. Non-use refers to the qualitative values, thus referring often to three forms such as; existence value, option value and bequest value, see *ibid* (2008, p. 158).
88. See *ibid* (2008, p. 159).
89. It is describing the content of information, a legacy being intact or authentic, see Ruijgrok (2005).
90. See Peacock and Rizzo (2008, p. 157).
91. See Throsby (2001, p. 28).
92. *Ibid* (2001, p. 29). “A great effort should be made to improve the exciting indicators in order to assess the attractiveness-capacity of a place...more multicriteria methods” (Fusco Girard & Nijkamp 2010, p241).
93. See Coeterier (2001) and Ipekoglu (2004).
94. Decorative elements such as, intricate constructions, skilled craftsmanship and original window frames are examples of quantifiable values, which consequently correspond to the Historic Quantity Value, H₃, in this study, see Chapter 3.
95. In nations like Poland the only way a building could be secured was to prove its many historical layers and as a result buildings ended up as patchworks of various historical epochs, Baranski Marek (1998 interview).
96. Throsby (2001, p. 19).
97. Quotation is from von Türtzschler (1997, p. 6).
98. Representatives from 21 countries attended the sessions and the Swedish representative was Thomas Adlercreutz, Central Board of Antiquities, ICOMOS (1997, p. 126).
99. “1. Governments (national, regional) should encourages private sponsorship and persuade the private sector for more assistance to the heritage. 2. Revise the tax treatment of beneficiaries and heritage, 3. Favour trans-border giving, receiving, cooperation and a

- friendly legal and fiscal environment, 4. Encourage economical activities and tax in favour for heritage organizations, 5. Create an international glossary of legal terms for protection of heritage, see ICOMOS (1997 p. 123).
100. The round table talks were compiled and printed in 1998, Boorsma et al (1998).
 101. No Swedish representative was present this time.
 102. See Boorsma et al (1998, p. 16).
 103. Ibid (1998, p. 17).
 104. According to Throsby, see Boorsma et al (1998, p. 49).
 105. Quotation is from Throsby, see *ibid* (1998, p. 56).
 106. Increase efficiency motivation of managers, rise in quality of service, increase technological development, administrative advantages, de-bureaucratization and democratization, see *ibid* (1998, p. 205ff).
 107. Increase in cost, creation of monopoly, quality loss (theatres), loss of employment, changes in non-economical values and threat to cultural traditions, *Ibid* (1998, p. 205ff).
 108. Council of Europe 1985 ratified by 74% of the member states, see Pickard & Pickerill (2002, p. 73).
 109. The surveys were carried out during field studies of 15 building conservation projects, in progress during 1990-2000 in Denmark, Germany, Lithuania, Poland and Sweden. A theoretical model over the conservation process was developed defining: object value, team, finance and legislation, and used as comparative index. All factors but finance were selected according to a definable framework and thus this was left to be explored. The outcome of funding analysis revealed three distinct finance structures, yet only two reflected in the processes; public and private funding. Public funded project were found to be; prolonged, building category selection occurred, to conserve and restore was vital, modern additions used and it was usual in Poland and Lithuania. Private finance was stable and brief, no category selection, adaptation frequent with traditional building material and representative for Denmark, see See Appendix 4, Skarin Pålsson (2001).
 110. The projects from Denmark, Germany and Great Britain were part of the private-public financed group. The countries representing the public funding group were Finland, Norway and Sweden. An ideal cast list over the actor groups as comparative index was established, by which the diverse participations in the groups could be registered. The results revealed that private finance meant financial pluralism, where many parties were involved for dividing the assigned roles and the donor incentives for funding affected the outcomes, but without making any limiting selection of building categories. Publicly funded projects, with one single financier engaged less parties and discussions were reduced to dialogs (financier-recipient) on project aims. The same individuals had many "roles" and the building category selection was confirmed. See Appendix 4, Skarin Pålsson (2005).
 111. See Trupiano (2004, p. 337).
 112. Allocated by the Government, Region, Province of the Municipality, see *ibid* (2004, p. 340f).
 113. The public oriented is signified by being democratic, free from economical criteria, bureaucratic and liable to political mediation. The market oriented distribution is striving for the best returns for sponsorship, allocation of resources to attract donations, flexible, high-profile initiatives and sponsor visibility, see *ibid* (2005, p. 338).
 114. The Ronchey Law 1993 refers to A. Ronchey, the culture minister 1992-1994. Ronchey initiated a reform of the state museum sector that lengthened the opening hours and allowed private companies to operate in services like ticketing, bookstores and restaurants, see Povoledo (2007).
 115. Such as ticket sales and shops, Trupiano (2004, p. 339).
 116. Quotation is from *ibid* (2004, p. 345).

117. The explanation “may lie in different tax treatments” (. . .)” more plausible explanation appears to relate to tradition” .European donations are either not deductible or only to a limited extent, see quotations by *ibid* (2004, p. 345).
118. Michael Kluger 1984, senior associate, Merrill Lynch Capital Market’s Helth Care Finance Department, New York City, see Kluger (1984).
119. Hospital renovations are a public concern in many nations, thus in the US both privately and publicly owned institutions exists.
120. Quotation is from Kluger (1984, p. 17).
121. *Ibid* (1984, p. 17).
122. In the US 1984, but also bond anticipation notes, demand obligations, tender bonds, *Ibid* (1984, p.17).
123. Hospitals have issued T-ECP’s since 1970 and by 1983 around 1 billion were on the marketed to investors and in total more than five billion in 1984, *ibid* (1984, p. 18).
124. Quotation is from Kluger and continues ...“30 million renovation project... with security cost on 5,8 %...” compared to a “long-term revenue bonds at a rate of 10,5 %” ..”would save...more than 1,1 million dollars a year, *ibid* (1984, p. 19).
125. See chapter 6.
126. South Street seaport, see chapter 4.
127. This could by some be considered advantageous since financiers are less interfering in the practical conservation work.
128. Skarin Pålsson (2001and 2004).
129. Research, education, design, architecture, handicraft, furniture, management and international office, see Skarin Pålsson (2001, p. 287).
130. This was both due to the fact that East Europe had a shortage of building material like wood and with poor conditions on heritage sites. Additionally it was made to meet the international agreements made on visualizing all later additions, as had been recommended in the Venice charter 1964.
131. Quotation from Herrera (2008, Interview).
132. Quotation from Karl Friedrich Schinkel 1815 from; „Memorandum zur Denkmalpflege“, Petzet & Mader (1993, p. 11).
133. See Appendix 4.
134. See Marston Fitch (1998, p. 46).

2. Methodological approach

2.1 Introduction

The methodological approach of this thesis is outlined in this chapter; from the system of inquiry, the strategies or research design used with the topic questions set to be answered and the final detailed tactics applied. The research study covers three chronologically separate periods; 1997-2000, 2004 and 2008-2010. The first two field studies are only briefly described in the chapters, and are instead available in appendix 4. The main focus thus covers the most recent investigations, steps 2-5, where empirical findings of the initial surveys provided the fundamentals for the whole inquiry. The process analyses of what is here defined as *heritage economics*, i.e. the heritage funding conditions in reality in step 1, used for identifying funding predicament and the need to assume a finance model, have called for new tactical solutions to be developed. The interpretation of the finance model as an arithmetical model, as applied here, has not only directed what measures to take methodically, but also rendered the study possible.

2.2 System of inquiry

Science theories, the assumptions, relate to research methods by initiating explanations of phenomenon, such as description and predictions, but also by redeveloping these to become generally valid, which the methods can then put into practice. Research methods hence regulate the act and become the instrument for verifying theories. The descriptive structures of theories can either be distinguished as positive or normative. Only a positive theory can make future predictions of the phenomenon studied, since this is based on identifiable causal links, and thus called scientific.¹ The normative is never questioned, since it describes the traditional solution applied to solve the everyday dilemmas and is not possible to falsify.

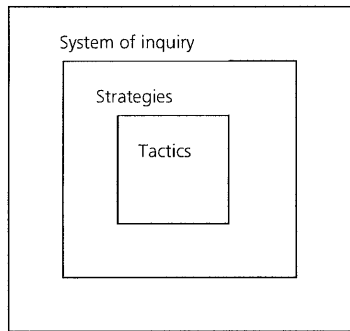

Figure 22.1 Kaplan's visualisation of the research process methodology.

In human science the requirement of falsifying theories is less stressed than in natural science, though feasible either by statistical sampling or detailed descriptions of an individual's own experiences of their contemporary social- cultural context. This dissertation matches the last category and investigates potential for securing heritage funding, by proposing a value stabilizing finance model grounded in building conservation practice. Here the experiences of individuals participating in the building conservation funding, have become the referable data. No objectified elements of measurable facts are available other than the social reality of the actors involved. The conceptual model by Kaplan², figure 22.1, visualizing the research process methodology is here applied to describe the theoretical approach of this inquiry. This often intricate process, at the most generalised level, illustrates clearly by the conceptual model, a *system of inquiry*, framing the *strategies*, into the most specified *tactics* applied. The exterior framework, the research paradigm, therefore directs the research design, with the research questions on the middle level. The specified techniques utilized are specified on the inner framework, but always set up according to the two exterior frameworks.

The ontological assumptions in knowledge and science make us accept certain intuitive truths, for instance that reality exists totally independent of our conceptions of it.³ The presumption also involves reality being distinguished by regularity where the course of events follows a specific pattern, which we can access through scientific studies. When these pattern structures can be interpreted a higher level of knowledge will be attained. The epistemological set of laws in science, finally help us to decide if the observation registered might be true or false. This signifies that statements of reality can only be true, when congruence with our experience exists and they follow the rules of logic.⁴ What epistemological and ontological grounds or argument to choose depends on the nature of the initial theoretical stance or discipline taken. In the post-positivistic paradigm

only one objective reality is predictable by probability, which the researcher can experience and verify with his senses. The epistemology therefore obliges the researcher to manipulate the conditions for the observed objects and to register its effects on the outcome. The deductive assumptions in other words are based on proven preconditions.

Contrary to this methodical approach is the basic ontological premise accepting socially constructed and multiple realities. Here objectified elements or observable measurable facts are lacking and these research paradigms are either referred to as the interpretive, constructivist, naturalistic/hermeneutic or the qualitative methodology.⁵ As this inquiry intends to develop measures to protect built heritage by augmenting the fiscal resources, it is imperative that the attainable facts regarding the present funding reflect the actual conditions. The motivation of today's financiers, which reveals their actual incentives for funding, is likewise required if it is to suggest any relevant future measures. These issues refer to processes of human actions, which can only be experienced as described by the parties involved by persons who the scientist has to meet and he then must interpret in detail. The interpretive paradigm relates to the phenomenological tradition and implies that lived experience is only available among the participants and its phenomenon accessible through their experiences and descriptions.⁶ Constructivist theory, analyses the invisible reality, which the powerful limitations of society's norms pass on through generations.⁷ The epistemological position in this study is that value-free objectivity is neither possible nor desirable, while reality instead is to be found in the interactive link between researcher and the involved actors or studied settings. From the detailed interpretation of the unaffected course of events, the *inductive* conclusions then can be construed from experience. In the corresponding Grounded Theory (GT) the interpretation of contemporary situations also begins without any preset opinion or theory in mind. Here the progression of theoretical direction and area of study, are drawn instead from the data that provides the guide for action⁸. In this study the related *Goal-free evaluation* by Scriven⁹ has been of major inspiration.

All research studies involving human activities in a social and contemporary context of multiple realities are referred to as qualitative or "*a pieced-together, close-knit set of practices that provide solutions to a problem in a concrete situation*"¹⁰. Criticism of qualitative methods often comes from the opponents, the advocates of post positivistic paradigms, but also involves the time consuming coding process, when preparing or handling a vast number of data and the fact that guidelines in this area are few. However the fact that only qualitative studies can investigate real life conditions of people's activities, explains its potential. Additionally, more flexible research designs may actually promote new scientific approaches, which could be useful even outside the limited research area.

The quality of scientific studies, according to Wang and Groat can be judged by how the following issues have been met; truth value, applicability, consistency and neutrality.¹¹ The truth value in qualitative studies involves dealing with the holistic approach which is why triangulation is used in multiple data sources. Applicability entails that one assumption can be transferred or proved in other inquires and here especially the detailed descriptions prevent generalizations and guard the researcher's interpretation. The quality and reliability of the coding process may be reinforced by natural quotations and neutrality can be reached when examining the conformity of data from the various methods applied, but triangulated with the researcher's own assumption. However for all interpretation-oriented research strategies, such as the qualitative, the narrative must be acceptable for a wide audience to claim validity¹² and be accumulative for future research.

“The cardinal principle of quantitative analysis is that causal and theoretical statements be clearly emergent from and grounded in field observations. The theory emerges from the data; it is not imposed on the data”
(Quinn Patton 1987)¹³

2.3 Strategies

The strategy or research design of this inquiry involves five steps;

- analysing heritage economics in practice
- assuming a value stabilizing heritage finance model
- acquiring funding
- economizing funding
- assuring funding

The empirical field observations of Step 1 were completed in 2000 and 2004 and, as mentioned, I have here only described them based on their scientific standpoint, but they are available as appendixes. My most recent studies, of steps 2-5, are completely presented in the chapters of this doctoral thesis, (see figure 23.1).

Step 1: Analysing heritage economics in practice

Empirical field observations of progressing building preservations, collected during a first broad survey and a second follow-up Study 1 and 2. Study 1: a qualitative-quantitative research methodology, using data obtained through interviews during visits to building sites in Lithuania, Poland, Germany, Denmark and

Sweden. The additional literature review involved national cultural significance, the individual case studies and research methodological literature.

Study 2: a qualitative-quantitative research methodology with data obtained through interviews in Denmark, Finland, Germany, Great Britain, Norway and Sweden. The literature used included individual case studies and research methodological literature. The findings from both surveys, which were further analysed in 2008, endowed hypotheses which therefore directed the follow-up studies, such as the financiers' project influence due to the individual value preferences, which were to be used as references for the finance model.¹⁴

Step 2: Assuming a value-stabilizing heritage finance model

The increasing funding deficit for maintaining the built cultural heritage requires resilient measures. Viable prototypes are lacking and thus I have re-modelled a prototype as a template, from the field of economics. An operational heritage finance model was finally assumed based on a first theoretical standpoint, using empirical facts from interviews and case studies. The literature review involved economics, cultural economics, research methodological literature and archived materials. The outcome established the need for a value concept.

Step 3: Acquiring funding (chapters 3-6)

To investigate the acquisition of funding involved at first establishing the mechanism of funding and secondly, employing a system to explore present as well as future heritage financiers. At first the definition of an inclusive value concept- tool was established; compared to other scales and empirically tested. The mechanisms of funding were penetrated and settled as to the relation of actions-accelerator-value. A mapping system of the financier group was then applied, the OMAS format, to distinguish the individual value preference (VP) and accelerators; the inducement for funding. The data was based on interviews and the literature review involved an historical outline on value definitions and the most recent published and unpublished facts¹⁵. The outcome revealed the inducements and capacity of three financier groups.

Step 4: Economizing funding (chapter 7)

The different building phases of a conservation project, which each generate separate costs, were initially indentified as likely areas for making financial cut backs and their advocacy potentials. Furthermore the marketing potential for generating income by *vertical archaeology* was set. The utilisation of the measures suggested for an economical funding was explored, by analysing recent building conservation projects. The outcome identified both positive and negative use.

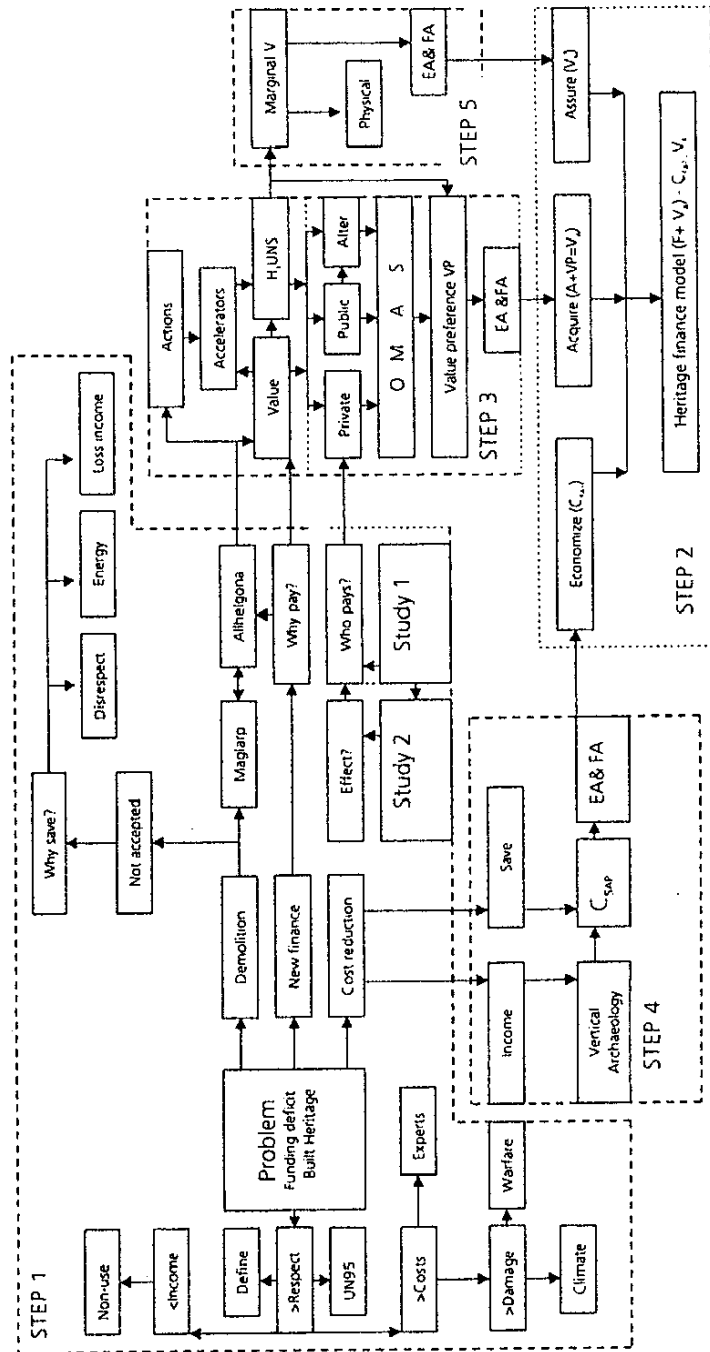

Step 1. Analysing heritage economics in practice; chapter 1, 2 (1997-2000, 2004)
 Step 2. Assuming a value stabilizing heritage finance model, chapter 2 (2008-2009)
 Step 3. Acquiring funding; chapter 3-6 (2008-2010)
 Step 4. Economizing funding; chapter 7 (2008-2010)
 Step 5. Assuring funding; chapter 7 (2008-2010)

Figure 23.1 The research design of this inquiry involves five steps.

Step 5: Assuring funding (chapter 7)

By assuring the *future gain*; that is to say the improved value of preserved historical buildings, the prospective funding will most likely be guaranteed. This involves taking concrete measures; regarding limiting the repairs of original constructions and by only involving empirically tested building materials. Additionally, it is important the preserved built heritage never fails to nourish the mechanism of funding, known here as the *actions*, by promoting the *accelerators* for ensuring a positive future gain, or marginal value, of built heritage. Recent building conservation projects were explored to analyse to what extent finance was assured. The outcome identified both positive and negative results.

2.4 Tactics; Step 1: Analysing heritage economics in practice¹⁶

2.4.1 Study 1 and 2

The first step of this inquiry began with a holistic analysis of heritage economics and entailed two field studies from practice. Study 1 arose during a unique era once the decayed, but still intact, building legacy of Eastern Europe, had become accessible to the West. Extensive sums of money were allocated by the neighbouring countries and exceptional building conservation ventures were launched. All kinds of historical buildings were selected, but often those with earlier historicities, where the buildings represented former national possessions for the financiers¹⁷. The study's objective was to establish a legible model theory, to be used for the conservation process practical work, by analysing the intrinsic factors and their significances. The four factors; object value, team, finance and legislation, became the framework index. Of these I have since focused deliberately and exclusively on finance.



241.1 Vernacular architecture, Poland; Nieborowo 34, in Study1 (left) and Lowest financed project, Germany; the church in Dammewolde, in Study 2 (right).

As literature on building conservations primarily touches on completed projects¹⁸ all debate on financial issues, once rendering the project possible and affecting the outcome, is otherwise forever lost. With the aim of contributing to future heritage economics, this survey had to commence practically on site, from a local perspective. For this reason the parties involved were personally interviewed and the data gathered, which revealed the funding and its effects¹⁹. With the intention of exploring the consequences of funding in progressing protection endeavours, only the qualitative method was possible to use.

For this in-depth study of real life conditions, the data collection cannot be constrained by any predetermined categorisations or hypothesis²⁰ but require a holistic approach registering individually occurring differences. Study 1 was developed, as already mentioned, with inspiration from the Goal-Free-Evaluation (Scriven 1972)²¹ as building conservation has variable goals²² and the method is appropriate for scrutinizing improvement potential in processes and frequently applied, for analysing educational programs. Both qualitative and quantitative methods are here employed in order to facilitate interpretation of the vast in-depth studies. This combination of methods, more easily provides the area of focus in the patterns discerned, than the standard qualitative studies. Careful and detailed descriptions of essential interactions are thus obtained through the richness of people's experiences, but on their own terms.²³ The inductive survey commences with filed observations on site and close contact with the respondents through interviews; "*Getting one's hands dirty*"²⁴. The gathered data builds toward general patterns which are then to be analysed without any pre-determined limitations²⁵. The outcomes lead to conjectures and formulations of hypotheses²⁶ and direct the next steps in the inquiry. A qualitative methodology of an inductive strategy therefore, at all times will be contrary to the hypothetical and deductive form of experimental designs. These are based on hypotheses to be verified or falsified and established prior to the collection of data commencement.

Study 2 also had a qualitative-quantitative research draft, set up according to the results from the first survey, yet this time as a specialized heritage funding survey. The purpose was to explore the distinctions regarding the parties' involvement in projects and preservation objectives, when either publicly or privately financed. With the limitation of an ideal cast list of five actors as framework index, the study investigated to what extent divergences could be registered. In contrast to Study 1 exploring funding in general, the financiers in Study 2 were pre-set on specified funding sources and conditions.

2.4.2 Scientific standpoints; reliability, validity and analysis

High reliability in statistical sampling is signified by as little deviation from “the standard” as possible and a truly random sample is required comparable to the generalization made. This is contrary to the sampling in qualitative studies, which instead involves selecting information-rich cases for detailed analyses to secure reliability. A number of sampling methods can be applied in qualitative studies to strengthen the facts and comprehend hidden incentives, interests or needs.²⁷ In this study *criterion sampling*²⁸ was applied where the selection of cases stands in relation to well known and congruous criteria. This was achieved by selecting cases according to three well defined standards, such as the building’s level of legal protection, here referred to as legal value (LV). This conveys its individual respect or theoretical value ranking with the manor house on the highest, the church on the middle and with vernacular architecture on the lowest level. The building conservations in Study 1 were also represented by the same time frame in all countries and this is essential, since all conservation measures are time-bound. The preparation of the survey, in other words, positioned all factors, but the finance factor in a definable framework – the funding structures, as a viable, was left to be explored. In Study 2 the level of financing determined the criterion sampling and in this case the highest and the lowest funded conservation projects were selected, with the objective of avoiding the traditional legal ranking of protected and listed buildings. A fixed time frame again was set and to make sure that both public and private funding would be represented, the countries were selected according to how their heritage funding traditionally is set. The structured organisation enabled the detailed collection of data but the framework also eased comparison of the cases. The selection of case studies for Study 1 and 2 was set during the initial pilot interviews with authority experts at the national heritage boards. Considering their professional competence, these buildings suggested to Skarin Pålsson as targets of study were regarded as being of national significance, since they were initially identified as some of the most respected building conservations in the countries.

In order to validate the analysis in qualitative studies, triangulation is applied²⁹. The concept can be practiced differently but signifies that one set of data is observed from several perspectives by varying the tools applied or observation made. The unique viewpoint of the parties involved in the preservation projects has been applied in these studies. By responding to a fixed set of questions the interviewees contributed with their reflection of the process. For each case study, nine respondents gave their impression of an identical project in Study 1. Other procedures would have been impossible since most of the facts registered through the interviews only existed in the social reality of the involved respondents. The

open ended interviews³⁰ were structured to limit variation of answers and obtain a systematic of scrupulous data, but still allowed for spontaneity. During Study 2 the respondents per project were only three, but then each represented a defined role in the conversations³¹ and the questions were multiple choice.

Analyzing and interpreting quantitative material implies bringing order to the data and organizing the distinguished facts into patterns, categories and basic descriptive units³². The content analyses in qualitative studies subdivide the data into themes and ideas that initially emerge from the respondents' answers which are labelled and put into cross-classification matrices. The outcome leads to speculations, conjectures and formulation of hypotheses. Theories emerge from the data and can never initially be imposed³³. The data from the interviews first of all is qualitatively coded³⁴ which leads to a reduction in available data information. This information is organised into themes called *variables*. These outcome variables therefore signify the numbers of available replies per question. The quantification that follows is when the variables are made relative for the final analyses³⁵ while calculated as percentage points. Pattern, structures or typologies³⁶ can finally be revealed statistically through the reduction where the majority is made representative for the group³⁷. Finally the *interpretation* can begin and entail attaching meaning or significance to the analysis in order to explain descriptive patterns revealed³⁸. In this dissertation I developed new graphical design illustrations of the matrixes in both studies to assist the analysis and assessment of the area of focus.

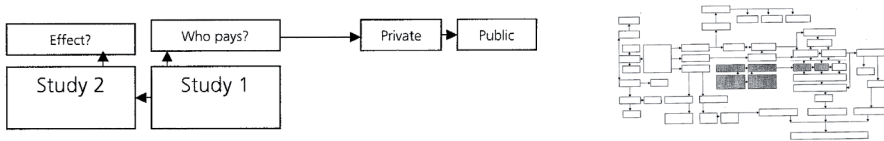

Figure 242.1 Step 1; analysing heritage economics based on actual building practice, study overview (right).

2.4.3 Proceedings and Results from Study 1 and Study 2

The objective of Study 1 was to establish a legible model theory, to be used for the conservation process practical work, by analysing the intrinsic factors and their significances. The four factors; object value, team, finance and legislation, became the framework index, of these I have since focused deliberately and exclusively on finance. To transform progressing conservation projects from practice

into theory, would make them available for analysing, and for testing what actual effects individual undertakings might have on the outcome, (see figure 242.1).

The qualitative facts about the conservation processes were obtained through interviews with the projects' participants. The answers signified by the majority opinion, in percentage points, were finally statistically transformed into clear graphical diagrams. Here the findings became quantitative figures on the conclusive graphical table, (GC1, App.1). By using this strict investigation structure, of coded data from interviews referring to the individual factors- their reciprocal interactions, individual impact and significance in the processes could finally be interpreted. This procedure reduced as well my own influence on the study, thus increasing objectivity.

In Study 2 the results achieved from Study 1 were transformed into this follow-up survey, which focused on the finance factor alone. Of guidance for this second case study was the possibility to verify or falsify the actual existence of an observed effect – that there is a distinct correlation between the two finance sources and process consequences of results. This more selective second survey intended to explore possible differences concerning an actor's involvement and funding objectives in relation to building types, in preservation projects, when funded either by public or private sources. With the support of an ideal cast list, it became possible to, out of the participants implicated in the heritage funding dialogue, register their involvement in, as well as their absence from the individual projects. The use of an ideal cast list in this way became a comparative index which could be used for observation, in order to say to what degree the group of actors varied in the conservation ventures. The research design was a re-development of the methods already established in the licentiate study of Study 1. The qualitative and emotionally tinted facts from the interviews were thus once more transformed, while coded. However, this time the data was transferred into objectively feasible quantitative as circle diagrams, in order to reduce the interpreter's subjectivity to influence the results. The outcomes in this way were concealed in the six segments of the circle that were equivalent to the number of answers, or variables referring to actor categories per question, obtained from the respondents. In order to reveal similarities and discrepancies between the privately and publicly financed projects, these findings were then re-arranged into two different tables; A- B, which were structured more and more according to a majority abstraction, in order to reveal patterns or tendencies of the actor's involvements.

The outcome from Study 1 revealed hypotheses on possible unique effects on the conservation process by the two major funding sources. The public-funded conservations revealed restrictions not discerned in the privately-funded ones. Public funding meant one single funding source, while private funding was plu-

realistic. In general public funded projects can lead to four obstructing limitations. Firstly the objectives for preservation must meet specified criterion; here only manor houses, secondly the democratic process becomes reduced since it involves fewer parties, thirdly it can lead to reduced funding capacity, since it is from a single source and fourthly, the conservation incentive reduces the chances of future revenues, due to a restricted non-use policy on the built cultural heritage. In Study 2 the apparent consequences of the two private and public finance sources, were further explored with focus on the two sources and of the earlier conjectures could be verified, as follows. Firstly public finance was once more confirmed as having a restricted selection of historical buildings, by focusing on early industrial building and secondly the democratic process may be reduced due to the limited number of parties' involved³⁹. According to the epistemological set of laws the outcome must be compatible with our experience and follow the rules of logic to be verified. The results from Study 1-2 were therefore further analysed in 2008, to direct the next study by characterizing the private and public finance group, in order to test the hypotheses revealed.

2.5 Tactics; steps 2 to 5

The second part of the inquiry entails the four last steps, including the establishment of the operational finance model, followed by the three investigations on how to acquire, economize on and assure heritage funding.

2.5.1 Step 2: Assuming a value-stabilizing heritage finance model

2.5.1.1 A heritage finance model in theory

The funding deficit, caused by increasing preservation costs, demonstrates that finance models are called for more then ever, but prototypes are lacking. The Maglarp-Allhelgona cases earlier described, disclosed two of the most common answers of funding deficit; either to decrease the number of heritage sites or to enhance with new finance. Additionally, the economizing of available financial assets also has to be considered, since budget restraints commonly involve this. The demolition option implying a decrease of built heritage sites to solve the funding difficulty will be excluded in the model, since it represents an irreversible act of disrespect viable only for its time, an inconsistent waste of energy as money and a hindrance of potential income. For the finance model proposal therefore the augmenting of funding and its economizing will further be explored. Increased financing has also to include how to settle the future finance prospects of histori-

cal buildings by launching revolving funding, as the expenses for buildings are unceasing and never-ending.

The finance model has to resolve project management by assisting the building preservation planning, if it is to meet the demands. However in order to settle how the distinct parts interact in theory, which collectively constitute the course of events, thriving authentic cases from practice are to be compared with those less fortunate. Here Allhelgona church on Ven can once more represent the first category while the demolished New Maglarp Church, the latter. The Allhelgona project began while the church was located in the vicinity of a public museum which was expanding. Four diverse financing groups were contributing and each was motivated by their own conviction of the excellent prospects for the venture. In the less fortunate New Maglarp case, the fate of the church was settled, by an escalating cost calculation for its conservation, the expansion of the adjacent new residential area and the 30 years of non-use, distancing the church from the community. Neither financiers nor any optional utilization could then be induced to contribute, other than by the bishopric, which generously paid for its demolition costs⁴⁰. In other words the external threat could not be met for Maglarp, because motivation was lacking locally and due to the financial “encouragement” from the diocese, which actually eased taking the irreversible decision. The many uniting features of the churches regarding architectural style, building techniques and even their technical condition, verify that external conditions at the time were crucial for the decisions made, not their physical appearance. The different circumstances hence endorsed the positive and negative value judgments, which finally directed the heritage funding recourse. A finance model thus must provide guidelines on how funding could be *acquired* from today’s financiers, if it is to meet the finance deficit in the expanding sector of indispensable historic buildings.

The building phases of separate building costs in the Allhelgona project were split up and distributed, that is to say parcelled out to different parties, so the constructional works for the shell-repairs became the owner’s concern. The building adaptation, from church to museum, was equally much promoted, as well as paid for, by the Landskrona municipality and the EU funding program. In this way, by subdividing and marketing the expenses according to building measures or phases, more financiers may be motivated to contribute. A deliberate ranking of order and size according to the urgency of the preservation also argues for the fact that costs can be split among investors, financiers and generations, thus attaining *economized* funding.

Future prospects for the Allhelgona church most likely will ensure revolving funding, since it is guaranteed both by the new museum use and since the scheme involved a refurbishment of the whole environment⁴¹ as well, generating local

revenues. A finance model can only be considered sustainable if it ensures its financial support from then onwards. To *assure* the revolving finance means that the preserved building is expected to bring a dividend, hence guaranteeing a stable intellectual value and that no constructional damages may occur.

The cases illustrated that exterior input directed the course of events and that the Allhelgona case alone represented a sustainable finance model ideal, with interacting components of acquired, economized and assured funding. To resolve funding management planning for historical buildings the following theoretical finance model is proposed:

A finance model must ensure that finance can be acquired, economized and assured for the built cultural heritage (recipient).

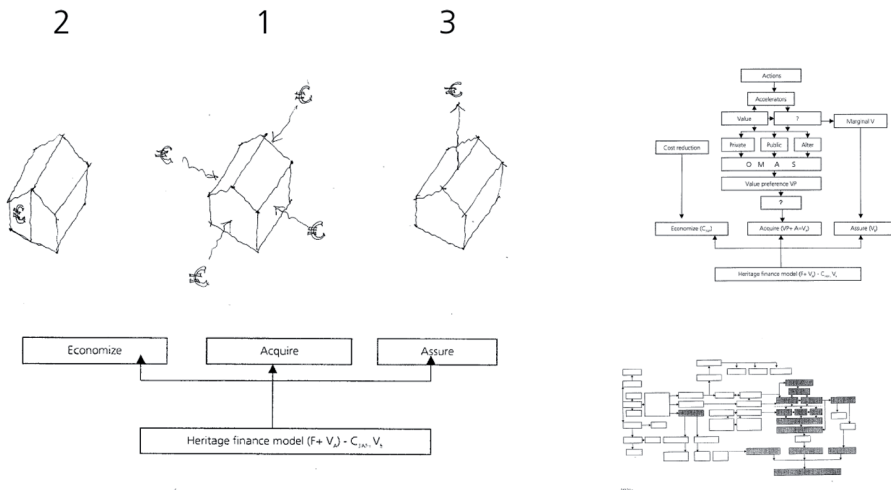

Figure 2511.1 Step 2; assuming a value stabilizing heritage finance model to ensure the acquiring (1), economizing (2) and assuring of funding (3). The research study overview is to the right.

2.5.1.2 The operational heritage finance model

A finance model in theory may possibly be established in order to provide an overview on the issues of concern. However, in this form the model will hardly be applicable in the real day to day finance planning. So unless the significance and interaction of how the acquired, economized and assured funding can be achieved, the model fails its purpose, which is its need to be operational. Finance models which are operational already exist, but within the field of economics.

The interdisciplinary character of this inquiry may explain the reason for addressing this field of knowledge to identify a legitimate role model.

Finance models within economics⁴² are computable and employed by companies for long term financial planning, hence they are operational. The most basic form comprise financial activities of a business and are applied for calculating potential profits from assumed costs and sales; sales minus costs equal profits,

$$S-C=P$$

S= sales

C= costs

P= profits

In order for this expression to be fitting for the finance planning in practice, yet more variables are added, which will affect the outcome. To convert this basic template for managing the funding planning of historic building, adjustments in the same way are required. The re-use of the financial arithmetic, equivalent to the chemistry mould for the finance model, has no intention of reaching a calculable level, merely to bring a graphical clarity to the process interactions that only a variable outline could express.

The two variables *cost* and *profits*, first of all can easily be translated into the variable expression. The “cost” then would equal to the subtracting building conservation expenditures and the final “profits” to the already discussed “value” of the preserved heritage. Still the question remains of how to incorporate “sales”, which refers to company revenue. To regard the acquired investments from the financier as a finance asset growth for the individual building, which it actually is, then this could be considered equivalent to an income, thus it corresponds to sales. A first adjustment of the finance model for company planning, but adapted for funding of historical buildings could then be expressed as follows;

$$F-C=V$$

F= Finance/investment from financier

C= cost conservation

V= value

The inconsistency of this model expression is that it suggests that *value* depends only on the level of funding and stands in direct relation to it. When considering that the field of culture economics has difficulties presenting a link between cultural value and finance, since the former is multidimensional⁴³ and lacking a standard unit, further adjustments still need to be made to the variable outline.

The first issue then to confront is whether a value variable actually is of one or multiple kinds in the finance model process. Here the findings from Study 1

(Skarin Pålsson 2001) have been of guidance, where this value issue was explored. The respondents participating in the conservation projects were specifically asked if they thought that value and appreciation of historical buildings were affected by the conservation measures⁴⁴. A vast majority were in fact convinced of a positive value increase for the built legacy.⁴⁵ This indicates that conservation processes, equal to the finance model, at project commencement convey at least two value variables, here referred to as; V_A and V_B . The first variable, V_A , is what initiates the financiers' funding (F) and of course this has to be positive and directs the project start up; $F+ V_A$. The second, V_B , corresponds to the estimated value raise at project completion and would in the terminology of economics, be expressed as the positive *marginal value*.

Future approximations applied under the concept of *marginalism* refer in this case to future positive expectations of activities performed, and are therefore related to value. Whenever products are bought or investments made, these conducts will always involve some sacrifices equivalent to the money spent; for instance the price to pay for a new dress. The loss, on the other hand, can be acceptable if also anticipating a positive outcome. This *expected profit*, or future gain – for instance to look attractive in the new gown, is in the terminology of economics, referred to as marginalism⁴⁶. An expected future value, of a preserved building, in this way could be defined as a marginal value, V_B .

When adding the two value factors the new model will be expressed as;

$$(F+ V_A) -C= V_B$$

F= finance/investment from financier

V_A = value activating funding

C= cost conservation

V_B = marginal value

The structure of the finance model now illustrates that the second value (V_B); marginal value, contains the financial investment (F), the first value (V_A) and separated conservation costs (C). This implies as well that the higher the first activating value is, the less finance is required since the cost for conservation work then will be less. This also is the case in practice since buildings respected by society, and highly valued, also regularly become maintained and in this way damage costs will decrease.

The operational finance model with the arithmetic variables can be expressed as follows;

An operational finance model must ensure that finance (F) can be acquired (V_A), economized (C) and assured (V_B) for the built cultural heritage (recipient).

In order to unfold what decisions that are crucial when it comes to the acquisition of funding (V_A), this step needs further clarification to explore the additional factors or interventions involved and their impact on the acquisition of heritage funding.

2.5.2 Step 3: Acquiring funding (V_A)

2.5.2.1 The mechanism of funding acquisition; action- accelerator-value

The motivation for all economic behaviours is said to be the notion of value, according to Throsby (Throsby 2001). This either involves an official value scale which might be developed as generally agreeable to any financiers inducing the heritage funding or an individual selection of values that they make their own, based on a set value guideline scale. Value awareness can be expressed in just as many ways as there are interpreters, from revealing a culture historical understanding to a financial insight, by prosperous revenues or avoiding value losses, thus limiting future costs. This explains the reason why a generally valid value scale might be impossible to establish. Building measures, which frequently can increase some value awareness in historical buildings for this reason, may also turn out contrary to others. For instance adaptations of historic buildings can bestow profits just as maintenance reduces unexpected cost increase. However, adjustments made to improve utilization of the historical constructions often have negative effects on culture historical value, since they imply altering original structures. Other than initiating judgements motivated by the buildings' physical appearance, heritage certainly can express strong positive or negative intangible value judgements. The perception of value within heritage sector for this reason has less of the pragmatic approach proposed by some culture economists and can be described as a multidimensional culture value, as discussed by Throsby in chapter 1.

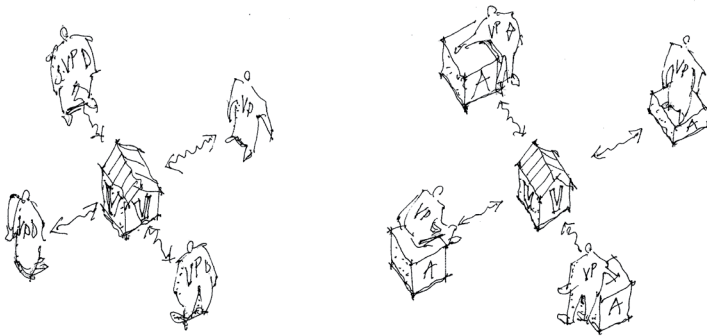

Figure 2521.1 *The notion of value; value and value preference (left). The accelerator is a perception capacity or agreement device of the interpreter to see specific values (right).*

Value estimations are perishable and vary over time, as illustrated in the case studies, described in previous chapter. The fact that one initial value assessment may transform so that later interpretations may convey new appreciation among other groups, underlines the need to investigate this phenomenon further, since this is essential for future funding augmentations. For example the worth of a newly constructed building primarily will refer to the pecuniary resources, invested by the proprietor for its erection, in financial terms. As it grows older it becomes less valuable from a new construction position, due to the inevitable decay of building material and the regular maintenance requests. Eventually the worth of the property owner's first capital investment might be replaced by emotionally related values, as the edifice converts into a cultural heritage. These new interpretations projected on the older building are now available and applied by a larger group of emotionally involved outside observers, such as local inhabitants. The initial fiscal asset input, the financial investment, has developed into an intellectual value and in other words, changed from a quantitative pecuniary worth into a qualitative innumerable *value* (*V*). If we can accept that the definition of heritage value may transform and widen over time from quantifiable financial worth to emotional or intellectual forms of intangible values, this explains why historic buildings cannot have the same appeal to all individuals in society. These distinctions instead must relate to the observer's ability, professional back ground or previous experiences of historic buildings, here called the individual *value preference* (*VP*). The phenomenon was obvious in Study 1-2 and explains the distinctions between private and public funded projects discerned.

To distinguish value preferences among financiers then would be to scrutinize the initial motivation to commence; that is the origin initiating funding in the first place. Independently of the target of affection, regardless if concerning individual buildings or historical city centres, value preferences will always relate to the contextual settings and the spirit of the time, as the Maglarp-Allhelgona cases revealed. These value preferences will be of guidance for most funding ventures, since they provide personal satisfaction and the feeling of doing something good, otherwise no funding will ever materialise. The value fluctuations continuously affecting the built cultural heritage make some buildings more agreeable at times, while others fall into decay. Since values are intellectual interpretations of the existing building features, this means that these qualities have to subsist in the physical constructions perpetually, as Alexander proposed (Alexander 1975)⁴⁷, but temporarily become “concealed”. The external course of events in the contextual settings here referred to as *actions*, then enable one to elucidate these hidden virtues and to revive them from time to time. Similar actions have been identified by Fusco Girard & Nijkamp as the *contemporary resources* (Fusco Girard & Nijkamp 2010) and by Mellander as the *Bohemian-Gay Index*.

However, the financier’s unique value preference will always decide what actually comes out of these outer stimuli. The perception capacity of the interpreter to specific values, or qualities, in buildings, objects or situations, which can induce behaviour of man, is here referred to as *accelerators* (A). These mental “agreement devices” motivate the financiers to take steps and disclose the reason why funding would be advantageous for him, or any benefactor. The accelerator’s phenomenon is labelled by Mellander as the *open culture premium* (Mellander 2008) and by Lindqvist as *initiators* (Lindqvist 2003). The fact that financiers have personal value preferences can explain for what reason not only one kind of historical building has survived to the present day.

A likely comparison of the phenomenon on; action-accelerator-value relation, might be the theory on the “investment accelerators”, launched by the economist Colin Clark as early as in the 1930’s⁴⁸. Clark’s theory was criticised at the time for lacking practical applicability⁴⁹. Acemogly (Acemogly 1993) nonetheless 50 years later redeveloped the presumption saying that positive output figures, or successful results, of earlier activities most likely inspire others to investment. He explains this conduct with the example of how one farmer’s deed can be of guidance and encourage the neighbour farmer to make future investments. This “follow John” behaviour theory Acemogly labels as the investment accelerator. An equivalent example would be when the chain store of IKEA established a new business in a scarcely populated town of north Sweden.⁵⁰ This *action* quickly induced other local businesses to establish themselves in the vicinity. The conduct of the chain store; the establishment, became the exterior stimulating action and

when mentally perceived by the managers in local firms- who saw an opportunity to improve their revenues, the action turned into accelerators of the assumed monetary output increase or the financial value (see figure 2521.2).

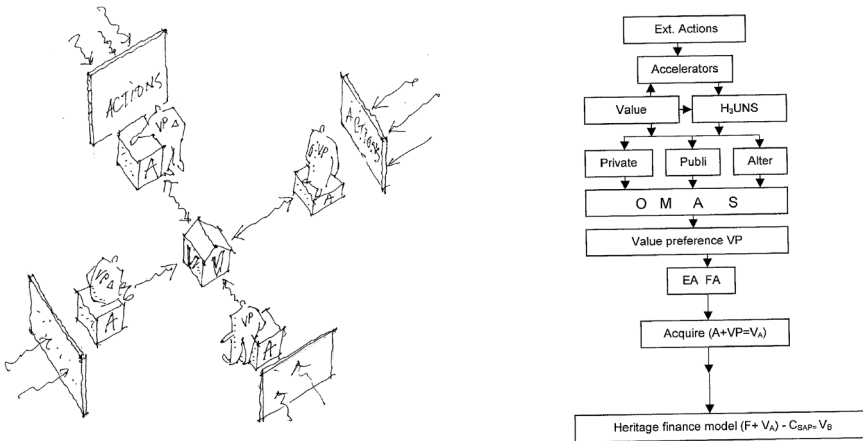

Figure 2521.2 *The mechanism of funding (acquisition). IKEA, such as the external action, stimulated financiers' accelerators to see value in buying land (here exemplified by the house) and set up businesses in the area. The research study overview of acquiring funding; Step 3, is to the right.*

The definition of *actions* applied in this thesis will be that they are of different kinds and subdivided according to their capacity for inducing accelerators of man so as to perceive unique values in objects, such as buildings, thus enabling changes. These recurring actions provide incentives, via accelerators, for groups in society suddenly to see values in built heritage, to act on, which had been temporarily forgotten. If no remote or external value regulators⁵¹ existed, there would never be any historic buildings for us to preserve, especially when considering the recurring times of neglect. In the Allhelgona case, for instance, the altered external conditions, or actions; the technical insufficiency in the heating system or the expansion plans of local Brahe museum, corresponding to precise accelerator (A), could as a result encourage the sufficient level of assessment, or perception of value units (V_A) for the financiers' investments.

In order to define the mechanism of funding; actions-accelerators-value, first of all a reasonable value concept must be established as a frame of reference so the individual value preferences (VP) of the financiers can then be attained. If the action- accelerators relation could be utilized for influencing value changes, in the way commercial advertising is capable of promoting goods, a regulator device might become apparent which can stabilize value, and thus improve acquisition of funding.

Based on the finance model $(F+V_A) - C = V_B$, the essential components for acquiring heritage funding from financiers (V_A) can be expressed:

$$A+VP = V_A$$

A= accelerator of value stimulated by (external) actions to funding
("agreement device")

VP= financiers value preference

V_A = value activating funding

The mechanism of funding acquisition enhancement is expressed:

action - accelerator- value ($VP = >V_A$)

This assumption for funding acquisition described will only be possible to test when an adequately definition of the values (V) in historical buildings is readily available. This value classification then needs to embrace the value preferences (VP) of all potential financiers. Once an agreeable value concept is settled, the relation to action and accelerators has to be explored before scrutinizing the disparate group of financiers.

2.5.2.2 Characterize the financiers (F); the OMAS format

The group of financiers of historical buildings today is most heterogeneous. This is why systematic analyses are required to explore these parties' reciprocal positions and individual significances. The previous case studies of progressing international building conservations (Skarin. Pålsson, 2001, 2004) verified that the funding sources had an obvious influence in the building projects, concerning the actual works performed, but also affected decision-making and team structures. The two major funding sources transmitting their own unique imprint; that is their value preferences (VP), on the preservation works were; the private or public financiers. The private financiers, of non-governmental associations or groups, have a national or international working arena. The public subsidy is more limited and primarily involves the country's own national funding⁵². Analyses of the active funding sources of historical buildings should initially describe their incentives for funding henceforth explain; *who are the actors?* The motivation which drives an individual association to provide funding might develop over time. When considering the broad selection of organisations, this could turn out to be an impossible mission. However, one major event which all organisations have in common is the funding commencement. This date of establishment, the *origin* (O), can most likely reveal the circumstances; the historical context and foci of significance, for the heritage funding practiced, thus explaining; *Why bother?* The

funding *methods* (M) utilized will always relate to the national finance policy and thereby explain the benefactors economical behaviour; whether the funding forms are based on financial or human capital, hence revealing; *What methods are employed?* The financier's origin and methods could then jointly elucidate the funding commitment, hence describing his own selection of potential values in built cultural heritage; the *value preference* (VP).

origin (O) + methods (M) = value preference (VP)

Once a concept of values are defined, then the key to their inducements, or the accelerators (A), projecting values may be revealed and reply to; *How to induce?* The value units will probably be encouraged on their own terms and this is why the accelerators have to be several. Value fluctuations explain that external actions encourage an accelerator to promote value. Finally a financier's reliability is of vital importance to investigate, since it anchors the financier's future funding capacity. The demand for capital for historical buildings is there incessantly and so it is vital for disclosing as well the solidity of the funding and explaining; *How sustainable is the funding?* One single financier can hardly manage all costs over time but an equivalent group be able to do so, through smaller contributions each time, hence making a group more compatible for building protections.

To characterize the present and potential financiers of heritage, then the following parameters to register are here referred to as the OMAS format. The date of establishment, *origin* (O), *methods* used (M), the *accelerators* (A) projecting specified values and finance *sustainability* (S). Apart from providing essential facts to illustrate the mechanism of heritage funding among financiers, the OMAS format will also render a comparison possible of the disparate funding groups; from private associations to public bodies, as a comparative index.

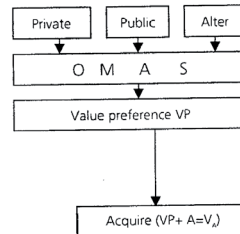
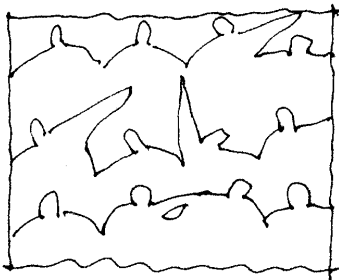

Figure 2522.1 *Financiers value preference, is the basic for funding acquisition.*

2.5.2.3 The scientific stance; reliability, validity and analysis executed

The acquisition of funding concerns the external conditions inducing the motivation among financiers to fund; the mechanism of funding and exploring present as well as future or long-term heritage financiers. The tactical approach chosen, as described in chapter 3, initially involved broadening a practicality based and currently used value scale of a multi criteria form; the HUNS⁵³. The scale was then compared and improved in relation to the theoretical value debates from written sources and outlined as a value perception chronology. The new value expression thus achieved; the H₃UNS concept was examined in consistence with the mechanisms of funding, in order to establish its correlation to and the nature of the action and accelerators. The arithmetic variable structure finally was used to exemplify the assumed relationship of actions-accelerators-values, based on examples from the value chronology.

To prove the consistency of the new concept, further investigation was made; firstly in relation to equivalent assessment systems, secondly as regards to the research front and thirdly empirically, in a qualitatively survey on three test groups. In this last analysis the criterion sampling was settled by the clear group distinctions concerning the discrepancy in skills of building conservations⁵⁴ as the criterion to ensure the reliability. The analysis was validated through triangulation, as all groups were confronted with the same assignment and fixed set of questions, direct quotations were also used. The coded interviews organized the answers into variables, which then were made relative for the final analyses, while calculated as percentage points.

Regarding the studies to map or characterize the current, as well as potential, financiers of heritage, in chapter 4, 5 and 6, the data was based on interviews and the organisations' own recent information channels on the Internet and brochures, since written sources were scarce.

The mapping scheme of the financier groups was applied according to the OMAS form, revealing their unique value preference (VP) among other essential facts. The 39 interviews⁵⁵ were either carried out during a personal meeting or over the telephone, then rewritten in text, and the selection of respondents was consistent with their professional experiences of funding administration. Since these data sources signify two viewpoints the intention was that these collectively would bring a more complete image of the financier, in order to assess reality. In this case the interviews revealed the unpolished and subjective impression of the organizations' funding effectiveness. The associations' own information channels, on the contrary, illustrated their impeccable front facade. The structuring and subdivision of the financiers into definable groups⁵⁶ strengthened their individuality as well as underlined their distinctions. References of cases from the building

conservation practice were also added. The outcome of the studies exposed the inducements and capacity of the financier groups; private, public and alternative. In addition the outcomes enabled the hypotheses from Study 1-2 to be verified.

2.5.3 Step 4: Economizing funding (C)

The operational finance model intends to augment new fiscal resources and meet the finance deficit, due to the expanding sector of indispensable historical buildings. Most likely the obtainable sums will never be adequate for the actual need, consequently solutions on how to make the best possible use of what is available, thus become vital. This is the reason why the finance model endorses a work approach to *economize* the monetary resources and involves how to plan the distribution of expenses in conservation practice. Distribution planning concerns the fact that the different building phases of a restoration project each generate separate costs (C). In the Allhelgona case for instance, the costs were distributed so that only the shell-repair was covered by the owner while the community and the EU program paid for the building adaptation. Conservation expenses split among many investors mean less expense required from each party, thus economizing the funding claim of the owner. The priority order of the building phases in projects regulates the intellectual and physical access to the heritage sites and this could affect its value recognition in society. Conscious distribution of the building phase planning therefore could increase the funding incentive among new groups, and hence be useful for heritage promotion. The size of the building conservation measures, as well will affect the expenditures. The “all at once” structure applied in some projects, may lead to unnecessary cost increases, since including less urgent conservation measures as well.

An intentional distribution of the building phases, and thus a separation of costs, may even generate proceeds from the conservation site itself, when buildings, such as *vertical archaeology*, with layers of history, become publicly accessible. To economize funding through distribution planning could involve therefore all of the following; splitting costs, adjusting the building phases, according to priority orders or size and attaining income by public accessibility. The question is to see to what extent these approaches are applied in building conservations today, (see figure 253.1).

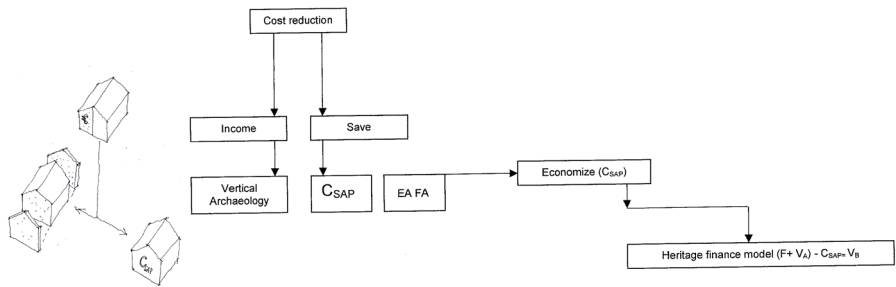

Figure 253.1 Step 4; Economizing funding (left) and the research study overview is to the right.

2.5.4 Step 5: Assuring funding (V_B)

Since all constructions which are exposed to an outdoor climate deteriorate, no preservation measures on historic buildings will last for ever. This was never the intention since traditional constructions are built up by layers⁵⁷. To prevent the irreparable damage occurring, the original constructions should be repaired continuously but only using empirically tested building materials. Consequently the costs for preservation measures will never cease and the need for funding remain constant. However, the historical buildings with a stabile value development will attain the funding required. For this reason, the finance model can only be sustainable, if it ensures that the preserved building legacy can nourish the mechanism of funding; as a *future gain*. This involves that buildings themselves, as *actions*, have to promote the accelerators and for these reasons, the legacy needs to remain of significance.

The Allhelgona case for instance will most certainly ensure a future asset value, due to the museum use and by generating proceeds locally, since it involves additional profitable activities for the community⁵⁸. The future asset value refers to an expected positive marginal value to be assured (V_B) and need to advance in the preserved building, to acquire the revolving funding. For this reason the marginal value has to exceed the funding activating value; $V_B > V_A$. In order to illustrate the extent of intentional measures taken to certify funding, contemporary preservation projects have to be explored.

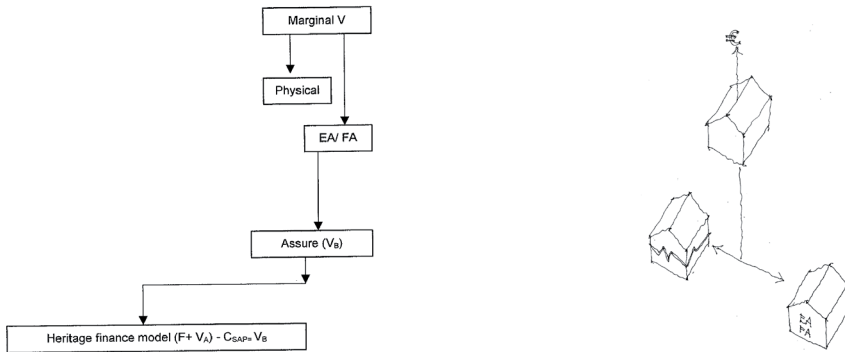

Figure 254.1 Step 5; Assuring funding for the preserved built cultural heritage (right) and the research study overview is to the left.

2.5.5 The scientific stance in steps 4 and 5

Three real life building conservations projects from practice were analysed; The St. Jakobi church, The Rossewitz palace and Murray’s Mills, in order to distinguish the extent of intentional use of measures for economizing and assuring funding. These surveys were based on 13 interviews⁵⁹ with participants involved in the projects. Additional relevant literature has also been used, such as archived material relating to the building objects and information from internet. Two of the building projects; St. Jakobi church, Rossewitz palace, were already presented in Study 1 but as they have progressed since then, the interviews have consequently been updated and renewed. Only the Murray’s Mills project has not been surveyed on site⁶⁰.

2.6 The heritage finance model assumption

The finance model is expressed

An operational finance model must ensure that finance (F) can be acquired (V_A), economized (C) through intentional distribution and assured (V_B) by achieving best possible future gain for the built cultural heritage (recipient).

The finance model expressed by arithmetic variables

$$(F + V_A) - C = V_B$$

F= finance/investment from financier
 V_A = value activating funding (acquiring funding)
C= cost conservation (economizing funding)
 V_B = marginal value (assuring funding)

The acquisition of funding (V_A) can be expressed:

$$A + VP = V_A$$

A= accelerator of value stimulated by actions to funding
VP= financiers value preference
 V_A = value activating funding; funding forms

The mechanism of funding acquisition enhancement is expressed:

action – accelerator – value ($VP = >V_A$)

The assignment for the next chapters will be to investigate the mechanisms behind the successful heritage funding of today. This involves; establishing an agreeable value concept (V) for the built cultural heritage and investigating the nature of and relation to the accelerators (A) as the actions. The value template then could be further used to distinguish the value preference (VP) and other characteristics of the private, public and alternative heritage financiers, based on the OMAS format.

2.7 Summary

To meet the increasing finance deficits within heritage economics, the main intention of this inquiry is to explore the future prospects of augmenting the fiscal resources for the built cultural heritage. For this reason a value stabilizing finance model based on practice is proposed, since higher valued, or respected, historical buildings seem better qualified to obtain funding than the ones lowly regarded, as the Maglarp-Allhelgona cases revealed. The system of inquiry of this thesis therefore is referring to the holistic qualitative research paradigm of human science, such as that the mechanism of funding involves people's behaviour. This methodology requires that all theoretical statements made are emerging from and grounded in field observations, and not biased by any preset opinions. To comprehend today's heritage economics in contemporary building conservations, the data was obtained from the detailed descriptions of the involved respondent's

own experience. The conjectures or hypothesis endowed from the data, then gave the references to further analyses.

The strategy or research design of the inquiry involved five steps; analysing heritage economics in practice, assuming a value stabilizing heritage finance model, acquiring funding, economizing funding and assuring funding. The first step was the holistic analysis of heritage economics through building conservations in progress. The second, based on these findings, a value stabilizing finance model was assumed. As viable prototypes are lacking, thus a template from the field of economics was re-modelled. The third step concerned the acquiring of funding and involved establishing the mechanism of funding, followed by the application of this system for investigating the heritage financiers. The fourth was on the economizing funding by the planning of the distribution of expenditures in building conservations. The fifth entailed ventures for assuring the future funding by nourishing the mechanism of funding and to ensure that measures were resilient for historic buildings.

The operational heritage finance model is expressed as arithmetic variables, not with any intention of being computable, but for visualizing the process as providing a detailed penetration. The graphical expression of the operative finance model, describing a potential process of augmenting fiscal resources for our built cultural heritage, thus was the guiding force behind the whole research approach.

Notes chapter 2

1. See Wang and Groat (2002, p. 78).
2. Kaplan, A., 1964, *The Conduct of inquiry*, Wang & Groat (2002, p. 10).
3. See Rosengren & Arvidsson (1992, p. 3).
4. Ibid (1992, p. 2f).
5. See Wang and Groat (2002, p. 32f).
6. The philosopher Edmund Husserl (1859-1938) established the modern Phenomenology. The epistemological approach is qualitative and explores values in life or quality of living, see Rosengren & Arvidsson (1992, p. 10).
7. The Constructivist theory was established by Berger and Luckmann who introduced the term *Social Construction*. In 1966 they published "The social construction of reality", Berger and Luckmann (1991).
8. The Sociologists Glaser and Strauss developed the Groundless theory and published 1967 the *Awareness of dying*. Columbia University, USA.
9. See Quinn. Patton (1987, p. 36).
10. Quotation from Denzin and Lincon, "Strategies for qualitative inquiry" 3, see Wang and Groat (2002, p. 177ff).
11. Ibid (2002, p. 35).
12. Ibid (2002, p. 86). See Chapter 8; Final Conclusions, Future Research; Development economy.
13. Quotation from Quinn Patton (1987, p. 158).
14. Appendix 4.
15. Exemplified by brochures and the internet.
16. See appendix 4; *Heritage Economics; empirical studies from 2000, 2004*.
17. Poland and the Baltic Nations; Estonia, Lithuania and Latvia were German, Danish and Swedish possessions in the past.
18. Facts are based on archived documents and printed sources.
19. Additionally, I have used my own professional experience of building conservations from Germany, Denmark and Sweden, which was essential as basic knowledge.
20. See Quinn Patton (1987, p. 9).
21. Ibid (1987, p. 36ff).
22. The 3-D effect of built heritage sites, see chapter 7.
23. See Quinn. Patton (1987, p. 10).
24. Quotation from Quinn Patton (1987, p. 16).
25. Ibid (1987, p. 9).
26. Ibid (1987, p. 158).
26. Ibid (1987, p. 15ff).
27. The qualitative research methodology provide a number of sampling forms as "Extreme or deviant case sampling", "Maximum variation sampling" or "Snowball sampling", Quinn Patton (1987, p. 52ff).
28. Ibid (1987, p. 56).
29. Ibid (1987, p. 161ff).
30. During a personal meeting or over telephone, which in both cases were recorded on tape. For further information see Appendix 4 and See Quinn Patton (1987, p. 112).
31. The roles were; State authority (SA), Private financier (PF) and Recipient/ owner (RO).
32. See Quinn. Patton (1987, p. 144).
33. Ibid (1987, p. 158).
34. See Rosengren and Arvidsson (1992, p. 257).
35. Ibid (1992, p. 257).
36. Indigenous typologies, classification system made up of categories that divide some aspects of the world into parts, in anthropology called an "emic" approach and requires an analysis of the verbal categories used by participants, see Quinn Patton (1987, p. 150ff).

37. See Project schedule, Skarin Pålsson (2001, p. 242) and Appendix 4.
38. See Quinn Patton (1987, p. 144).
39. The more limited the group is, in number and professional stance, making the decision on what will be the “correct” building to fund, the more un-democratic and time reliant the decisions most likely will be. This might prevent value increase for built heritage to reach society and thus the limit the funding incentives.
40. The grant from the Bishopric was the so called *Silver Money*, Romberg, T. (2008, interview)
41. It included other buildings on the site, a renaissance garden, a café, an adjacent hotel and restaurant and private bus company.
42. See Finance Models (2009, Web).
43. See Throsby (2001, p. 26ff).
44. Open directed questions and the answers were coded into; *higher value, unchanged value or lower value*, see Skarin Pålsson (2001, p. 36).
45. More than 80%; that is 9 out of 11 projects, see Grapichal Matrix, Appendix 4. Skarin Pålsson (2001, p. 243).
46. Marginal production could be the future gain a company can make, after they invested in new machinery, with the intention to increase the production and revenue, see Eklund (1995, p. 40ff).
47. See The Oregon Experiment, Alexander (1975, p. 15).
48. “Condition of economic prosperity” 1939, “Theories on marginalism and marginal productivity”, see Pupa (2009) and see Daron Acemoglu (1993). See Fusco Girard & Nijkamp (2010, p. 3), Lindqvist (2003, p. 312) and Mellander (2008, p. 175). The Mellander study “There Goes the Neighborhood. How and Why Bohemians, Artists and Gays Affect Regional Housing Values” describes an effect which was tacit already 1323 when the Grand Duke Gediminas invited monasteries to get settled in Vilnius to induce prosperity, Skarin Pålsson (2001, p. 72).
49. Clark, C., 1939, “Condition of economic progress” and the author of marginal productivity, see Pupa (2009). See also the discussion on how comfort/discomfort of man has to do with speed (level) while pleasure with the acceleration/deceleration (change) of one’s emotions; the Law of Hedonic contrast, Scitovsky (1976, p. 61f).
50. IKEA was established in the town of Happaranda in 2006. See “Supply-side economics” (utbudsekonomi), Eklund (1995, p. 304f).
51. External actions, which are stimulating the accelerators of groups, in order to perceive values in built heritage.
52. However public subsidies are frequently used at times to support preservation project or rebuilding internationally through Aid programs (SIDA), but this issue is not included in the study.
53. HUNS value concept was established already in Study 1 and refers to historical (H), use (U), nominal (N) and symbol value (S), see chapter 3.
54. This thought refers to the *Experts, Students and Laymen*, see chapter 3.
55. The private financiers were 16, the public ones 19 and alternative financiers were 5.
56. Private financiers were divided into four groups, public in two, but the three alternative financiers were individually discussed. To understand the present heritage funding, little can be found in written sources which is why interviews and the organisations’ own direct information channels on the Internet will be the proper approach.
57. The external coatings of plaster, boards or paint must forgo, or weather, for the sake of shielding the essential load bearing constructions.
58. The renaissance garden, a café, restaurant, hotel, bus transport, see note 41.
59. The interviews primarily were by telephone, but a few were also held face-to-face during meetings.
60. Interviews with the involved actors only over the telephone.

3 Value

3.1 Introduction

The definition of value is vast and generally applied in many disciplines, which is why value as a concept will initially be outlined in this chapter. The actual proof we have that value recognitions, though changing, have been essential and managed to preserve built heritage, is the fact that there are historic buildings still in existence. In order to scrutinize the mechanism behind the present heritage funding, an existing and empirically grounded value concept, developed during Study 1, has here been remodelled. The intention of the new value concept here presented was to establish a useful standard tool which could coincide just as well with the value theories within the heritage sector, as with the ones used in actual building conservation practice.

Further investigation of the value units enabled one to distinguish the accelerators and the potential actions by analysing the course of past events. To strengthen and legitimize the suggested value concept further, it has also been tested against five equivalent value models, the present research front and finally in practice within three test groups.

3.2 Definition of Value

3.2.1 Value exclusion or inclusion and legal value

John Ruskin, who was one of the icons of monument preservation in the 19th century, assumed that value in cultural objects such as arts and architecture, had the ability to transmit over time like a divine force to its users, since this value is established by the originator during the creative process and so integrated in the items itself¹. The definition of value has been extensive over times but the two generally utilized distinctions are either that value may express the quantity of goods; to measure, rate or rank; or to differentiate a quality, such as the property of objects. Instruments within science can today allow the measurement of all fields; from the particles in the atoms to the universe. Nevertheless the dimension of quality is still worthy of discussion.

One approach to the issue would be to limit the value definition and just distinguish its broad and potential use as for instance, to be a device for exclusion or inclusion of valued or desired features in objects. Value *exclusion* for example is applied when a football coach sets up a value standard definition “device”, to ease the selection of the best players for his team. In this way he may be convinced of excluding the less suitable ones. The value *inclusion* is contradictive to the former, and represents the approach of the commercial advertising of today; marketing. In order to launch the larger enterprises, as for example an energy efficient wind power production, extensive capital will be required always. All the benefits, or values, are presented to the presumptive financiers in such a way as to convey the project splendour and qualities. In both situations a value classification is defined but with the vital distinction that one concerns the value communications in a small group while the other in a larger. The coach, most likely, is less motivated to explain his value categories for others and may even intentionally wish to keep them as professional secrets. For the wind energy investment, the dialogue is fundamental. Here all values, positive results and advantages have to be obvious to all involved; producer, investor or engineer.

These expressed distinctions; exclusion or inclusion of value, are of relevance for the heritage sector since they distinguish the old from the new method of valuing historic buildings. The intentions of value assessment in 18th century France, were initially to ease the selection of what historic buildings to secure with legal protection, building values which were hence set by exclusion. The evaluations selecting some heritage from others were agreed by a small but homogenous group of professionals. For this reason this form will always be more restricting than the classifications which are intended to be accessible for decision making in general. Although the aim is to perform an objective evaluation, external factors will inevitably influence the outcome, just as evaluator’s qualification do, as does the timing. Since public evaluators of heritage authorities often have corresponding professional backgrounds² the value analyses will involuntarily be partial and fit this group the best. All value assessment which only considers a narrow historically angled perspective thus will be more vulnerable and might impede confirmation of others. Experience from the Baltic countries after 1945 proves that even solid preparations for securing the value of monuments can result in a sudden drop in value overnight when not appreciated by the new political ideologies in power. Moreover, inhabitants of historic city centres might be less initiated in the field of art history, but much appreciative of the historical environment. Top-down enforced restrictions made on cultural legacy based on limited value perspectives can make even the most dedicated inhabitants react with hostility. Well intended scrupulous norms for building protection therefore

could have the opposing effect in reality and be ignored if ungrounded in the community.

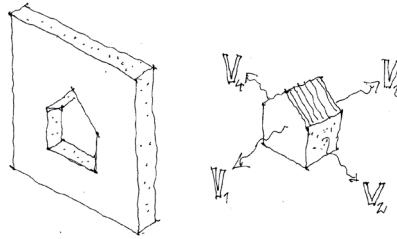

Figure 321.1 Value exclusion; to fit a template (left) or inclusion i.e. all values.

Since intellectual values (V) are constantly under the influence of the spirit of the times in society they will be variable, due to changing appraisals, attitudes as well as norms. With the attempt to stabilize these fluctuations, protective legislations, such as listing of heritage sites, have been established as a value guarantee by the heritage authorities for decision making and are here referred to as legal value (LV). The natural flexibility in values interpretations over time implies that these can be stimulated and the appreciation of heritage grows among people. The equivalent legal value (LV) on the other hand is the static and institutionalized structure, which is artificially ensured by listing according to grading and regulatory interventions. The national forensic framework of legal value hence reflects the norm that once was generally accepted, especially among the value authors, at the time that the law was passed. In geographically marked off areas, the chronology of listing has been unified historically and is often linked to the built heritage previous use³.

The major problem with the legal value judgements is that while the public body; the heritage authority, wishes to ensure its own edicts are observed, yet they hardly ever had the financial assets required for allocation to ensure its instructions are followed, since funding is regulated in the policy of a financial plan. In spite of all good intentions and competent studies prior to the statutory being set, the legal value structure can be undermined, which is what happened, as mentioned in Eastern Europe.

3.2.2. Value definitions in economics

Because value in economics concerns the numerical worth of money it is understood that value is used for quantifying goods and contrary to the concept of value in the heritage sector, where it is applied for assessing the property of objects. However, this has not always been the case. The economical definition of value has developed over time and is sprung out of theories which intended to simplify or gain control over the complex issue regarding consumption. The value approaches early on were linked to an idea and existence of a *natural value*⁴ that later became theories on forms of permanent or *absolute values*⁵. Smith in the 18th century began to make a distinction between values in commodities; to satisfy the users' wants as a function and that value form which a buyer is prepared to sacrifice, that is its price⁶. This prepared the grounds for the ideas that value was determined by the cost for the production of goods. The currently still discussed and empirically testable *utility theory* also adds the individual preferences or the consumer's behaviour. To distinguish a quantity demand over time these individual preferences are then based on some fixed assumptions⁷. The theory is still considered incomplete by some economists and the reason for consumption, or high value estimations, is still undefined⁸, but is probably far more dependent on the social context of man, than had earlier been assumed. It is argued that if market prices mirror a value, then price could also indicate the existence of a value, though this is never possible to measure⁹. Scitovsky's study (Scitovsky 1966) is therefore most interesting since it combines psychology and economics together when scrutinizing human desires and paradoxical dissatisfaction.

During the last few decades culture economists have discussed the definition value for cultural heritage, applied however in a financial viable terminology, with the intention of initiating further investments in culture. New groups of economists have now entered the heritage value debate, but from a completely different angle and with a value inclusive approach, which therefore corresponds to their background in economics. Ruijgrok (Ruijgrok 2005) has remarked on the built heritage value definitions of today, as identical with "expert judgement"¹⁰ and consequently too distant from the explicable level. The financial interpretations are left out and so the only opportunity to influence political decisions on demolishing or maintaining built heritage is lost, according to Ruijgrok. The financial perspective which has been introduced by the culture economists actually focuses on the need to widen the value scale, since fiscal worth is already used elsewhere in society.

A value classification guided by the *inclusion* instead of the *exclusion* approach to historic built legacy, might be more generally respected among stakeholders, since it refers to a wider part of existing qualities. Since 1995¹¹ culture, such as the

built heritage, has been officially considered essential global assets, which have the capacity to provide economic growth. This indicates that built heritage ought to be value inclusive in the 21st century and represent a marketing approach adapted to fit many parties. A new value scale then should be developed in order to scrutinize the mechanism behind funding. This may also reveal the essential accelerators which are capable of stabilizing the heritage values and this is crucial for funding.

3.2.3 Assessments from actual building practice

3.2.3.1 Utility value (U)

The fact that a non-use was among the severest threats of existence to the built heritage is verified by the multi-utilization that historic built heritage embodies. An inability of adjustment to new functions was intolerable in past societies and a guarantee for its up-keep. For this reason a vast majority of all historic buildings had an alternative use, a purpose of fulfilling other needs, than they had originally when first erected. The continuously employed, as long-lasting, building material actually came to the rescue of some buildings at times. Its high appreciation was both for the durable fabric as such, but also because of the embodied energy¹² which it represented¹³ and thus an excuse for making some buildings indispensable. Numerous examples of re-use referring to function or building materials are known from the past and these pragmatic recycle activities can be found in any nation or at any point in time since they function simply to cover basic human or ideological needs.

In the city of Trakai, Lithuania, for example the 13th century Bernadine monastery was knocked down, the brickwork was re-used for the duke's castle in the 14th century and 500 years later the same masonry again came in handy for the construction of the present Neo-Gothic Church¹⁴. The Reformation in the 1530's, likewise gave the governing classes of kings and nobilities, for instance in Denmark and Sweden, the right to re-use the masonry from local monasteries for the construction of their new palaces¹⁵. The two examples reveal the effect of a utility value in built legacy, though considered as the embodied energy of building materials.

Churches such as Saint Petri¹⁶ in Copenhagen met another destiny in the 16th Century while the building was re-used as a foundry for half a century until donated to its present owner, the German parish and again turned to sacred use. During the Emperor Napoleon's besiege of Stralsund¹⁷ in Germany the medieval Saint Jakobi Church was used as a horse stable and prison for a year, but later on regained its original function. The church once more was kept for secular use

after 1945 until 1990, when it was turned into an engineering workshop¹⁸ and the towers used for social gatherings. Today the Saint Jakobi Church interior has been rebuilt once more and since utilized as a theatre and museum¹⁹.

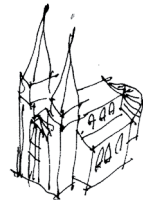

3231.1 *Utility value; Evangeliku Liuteronu kirchės as basket hall (left), during the restoration in 1995 (entre). The symbol value expressed in style purification and the Cathedral of Cologne (right).*

An even more spectacular example was the recycling of the Evangeliku Liuteronu Kirchės²⁰ which originally was erected in the 17th century as the first Lutheran church in Vilnius, Lithuania. The famous exquisite baroque stucco interior, by architect Glaubnitz, was fully visible thanks to the hall construction in the church, which is characterized by having no interior columns. The confiscation by the Lithuanian state in 1945 initiated a total rebuilding of the interior in 1950. New concrete joists on cast concrete columns turned the first floor into a perfect basketball hall and the ground floor into a workshop, but in the 1990's the church was once more remodelled for sacred use²¹. Modification of utilization also inflicted on the value, but it helped also to save one of the few remaining Swedish Franciscan Monasteries by transforming it from hospital, to brewery and finally into a historical museum²².

Restrictions preventing alternative utilizations of historic buildings on the other hand have proved to lead to negative outcomes, as with the demolition of the new church of Maglarp in 2007 already discussed. The baroque church of Svc. Mergeles Marijos Basznychia in Vilnius also should be mentioned which indeed was spared from all extensive interior rebuilding projects of the 1950's, but was instead left to decay since being closed in 1945 (see picture on front cover). The temporary adaptations of the historical monument described were insensitive and in some cases devastating for the original settings. Nevertheless, the fact remains that the temporary use actually assured continuation. Churches temporarily turned into stables, prisons or even basketball halls can be understood as a conscious misuse executed by a foreign power to trample on what at the time was most holy for the local inhabitants. The reclaim of churches for industrial production signifies a more pragmatic approach since the solid brickwork con-

structions actually provided fire safety and similar premises were rare in the 17th century.

In a more recent re-use adaptation; the Tate modern in London, a former industrial structure²³ is now after an extensive interior rebuilding, used as a showcase for British and international modern art. This example makes our generation no different from our forefathers and illustrates that incentives for a re-use of a barely hundred year old industrial complex like the Tate, is due to the changing value priorities. Properties which are considered inappropriate for alternative utilizations for this reason might be the most exposed and in the danger zone for demolition or slow deterioration. Well intended limitations and regulations on use for the built cultural heritage in this case oppose its original intentions; to protect. Historical buildings that over time were selected and regularly adapted for a multitude of new uses, could be said to possess a higher use value than average. However to predict these value variations is inaccessible since society under the influence of the spirit of time sets the assessment on built cultural legacy independently of previous appraisals made.

That New Maglarp Church would be demolished after only 98 years, its bricks transported to be recycled for a conference facility²⁴, (see 3231.2) in a turn of events is a development no parish member could ever have imagined on the day of its inauguration in 1909. The church destiny discloses once more the negative effect for built heritage when the utility value refers to pragmatic reuse of the embodied energy²⁵ since it is not protecting the built heritage in situ. A continued adaptation of historic buildings for new uses will however prove that they possess high functional qualifications. These credentials have made them indispensable to societies over time and so they have been protected. This proves the existence of a utility value (U) which concerns the utilization of the built heritage in situ, not its materials, since this is ultimate. Since the previous use value will always be unaffected by new judgments, as society changes, the future development of its worth is inaccessible and unpredictable.



3231.2 *New Maglarp Church today at Sysaw as a conference facility in front of the industrial plant.*

3.2.3.2 Symbol value (S)

Just as identifying use value by looking at historical applications of heritage protections, the judgements of historic buildings linking to political, religious and social significance have also brought about value changes for society over time. In particular subsequent social upheavals or changes in use were always considerable. Ancient monuments were often respected from different perspectives owing to the contemporary settings in society and the Parthenon temple²⁶ for example has until today had four totally different guises; such as temple, church, mosque and museum exhibit.



Figure 3232.1 *The four guises of the Parthenon temple in Athens; the temple (1), the church (2), the mosque (3) and the museum exhibit (4).*

The immense political impact of three-dimensional heritage as national icons also explains the extensive bombing of Warsaw, or of medieval German cities, during the Second World War. As signs of human achievements, the legacy mirrored times past and the national cultures which were all jeopardized when exposed to destruction. These strong manifestations of political or religious ideologies exposed the build legacy and at the same time confirmed the existence of a second obvious but immeasurable value classification; the symbol value (S). This symbol value can even appear more aggressive in time of peace as when the Putbus palace in the Eastern German republic was blown up in the 1980's, just as the Buddha statues of Bamyang were in 2001. Even the destruction of the World Trade Centre²⁷ represents this value sign. The value parameter is capable of revealing contradictive judgements; either expressing the strongest aversion on political grounds but also the sincerest sign of the joys of indispensability.

The first large scale expression of this latter indispensability symbol value came with the completion of the Cathedral of Cologne in the 1870's²⁸, which sparked off the style restoration which followed in the 19th century. The nationalistic driving force of symbol value also was the inspiration for the neighbours of Poland and the Baltic countries, to support building conservation ventures in the 1990's. By means of their heritage funding, Sweden, Germany and Denmark wanted to protect the historic building legacy which once was a part of their national possessions, though today these buildings stand on foreign soil.

3.3 Developing a value scale in theory

3.3.1 The rear-view mirror assessment; HUNS

The design of a value concept as a temporary assessment device was already begun by myself during the process analysis in Study 1²⁹. A multi-criteria method was then set up and tested for the *value* factor. The new classification had to be broad and value inclusive to fit any building category, since manors, churches, but also the vernacular architecture were studied. It also had to be independent of the current legal protection. The logical approach to enable the comparison of the sites was a historical overview which illustrated the value fluctuations over time for each building. The basic units for judgements had at first to be established as well as a suitable rendering design which could visualize the historical progression. One requirement was for this reason to structure the value analysis graphically. One of the main objectives was that the indistinct but frequently applied *historical value* (H), which is fundamental to justify a legal protection of built heritage, should be supplemented and specified in more detailed value units. Altogether this new value structure should cover a wider value perspective, than was commonly applied, and improve the relation to practice. Four units for value were in this way specified; historical-, utility-, nominal- and symbol value. The impact utility and symbol values over time have already been discussed and the historical value was of course given. The novelty for this reason was the nominal value which originated from the interviews with professionals and respondents; in the building conservation cases studied, and from personal experience as well³⁰.

The first historical *value* included all qualitative and quantitative features which may confirm a link between built legacy to the past and this was also the least dependent on the spirit of the times. Ruins like the Parthenon, or other ancient remains, have considerably high historical value and this prevails. No matter the level of constructive instability or decline due to weathering, the time of creation will remain the matchless motive for the respect due. The second unit, *utility value* (U) was a measure of the buildings' capacity for utilization and what they have been utilized as. A church in use, is so to one hundred percent, but with split utilization as a church and a museum, this value level will then be reduce to half. The *nominal value* (N) was the third unit for estimations and this disclosed the financial investment made. Recently preserved historic buildings have a higher nominal value whereas with those neglected, or exposed to poorly performed maintenance, on the contrary the value drop, as it leads to unexpected costs. The fourth variable the *symbol value* (S) could be linked to the building function in the sense of what the built heritage represents for society at times. Its ability to increase nationalistic feelings makes this value unit endanger historic buildings

when turning towards its extremes of negative exposure, which could be the case in political conflicts.

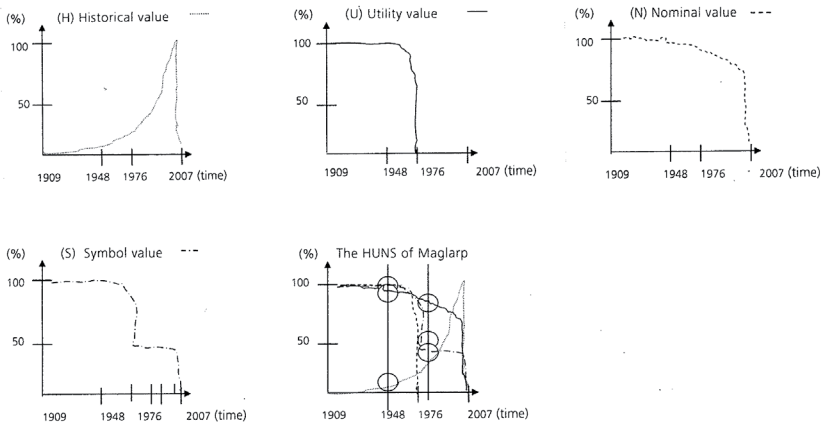

Table 331.1 *The HUNS value development of New Maglarp Church; historical value, Utility value, Nominal value and Symbol value. The valuation diagrams suggest that value assessments represent only one point in time. They are constantly changing, which is why consistent value judgements can only be set with hindsight. However, historical value can be said to have a stable progression.*

As explained in the valuation diagrams the value perceptions for historic buildings will always be unique for their time and reflect first of all the individual progression, (table 331.1). All value assessments, though objective, can only be rear-view mirror images with hindsight and the future estimations will still remain unpredictable. The fact that significant historic buildings which temporarily have been hit by sudden value losses suddenly may regain respect and be spared proves that the values remain indefinitely³¹. As exemplified by the Maglarp-Allhelgona projects, the values actually existed in both sites, even if they were concealed. The new external conditions or *actions* could then make the assessment for one of them to revive, which initiated the investments for re-use.

The official value units agreed on by heritage authorities for establishing legal value (LV) protection are theoretical and based on value exclusion. These also were established to be guiding for a limited group of heritage authority experts and never intended originally for civic judgements, which is why these were misinterpreted by people in general. The built cultural heritage officially represents significant assets which can contribute to economic growth. New assessments consequently need to be based on value inclusions, which are agreed on by many,

by enabling all to find their value preferences in heritage, in order to guarantee the built legacies' future existence. Value analyses as illustrated above may be less useful for setting contemporary value judgement, but are most vital as an instrument for disclosing its potential values and significances for the financiers; in other words for the marketing of the built legacy; its capacity.

Motivation for economic behaviour such as funding, according to Throsby, is the notion of value. For this reason the assumption must be that values in built heritage are incessantly present since the funding for its protection has regularly been renewed. A value concept, like the HUNS, can for this reason become a useful template to apply as temporary value "standard" and a tool for scrutinizing the mechanisms of funding. This involves analysing what the enticement or pulling power of today's heritage financier actually is and to map hindering impediments likely to increase, so as to stimulate economic conduct. Though a perfect and final concept of the definition for heritage values might be unattainable, since it is a concept constantly changing in relating to time and individuals, yet the aim must be to arrive at a value consensus which is broad enough to be generally agreed upon.

The question is if the HUNS concept, based on the empirically grown value idea from practice³², would be compatible to the equivalent assessments which have been employed in heritage theory. For this reason, in the next paragraph a chronological outline on the progression of value definitions in written sources has been outlined, from early on up to our time. To establish a congruence of the value definitions used in practice and theory, most likely additions or subtractions to the HUNS concept will have to be made.

3.3.2 Overview of value concepts progression in theory from 1600 to 2008

1600-1749. The rediscovery of *De architectura libri decem*; Ten books of Architecture, written by the Roman architect Vitruvius³³, subsequent translations and popularity spread, made the European culture elite re-establish respect for or value of classical architecture from antiquity, in the 16th and 17th centuries. Vitruvius's value definition of quality in architecture to be the perfect balance of *Venustas* (beauty), *Firmitas* (solidity) and *Utilitas* (use) became the state of the art. The Romans early on had already made practical use of their ancestor's monuments, both when adapted as churches³⁴ but also as quarries or stone depots for new constructions. The dismantled decorative parts were also recycled to embellish churches as well as private villas³⁵. The spreading of Vitruvius facsimiles inspired new literature³⁶, which had huge impact on artists as well as architects who investigated and copied the antique roman expression³⁷. The new awareness

furthermore initiated later on the privately financed archaeological excavations in Rome, Herculaneum and Pompeii in the 18th and 19th Century³⁸.

1750-1799. The antique temples in Greece, isolated from travellers since the Ottoman invasion in the 15th Century, were next in turn to be rediscovered in the 1750's³⁹ by explorers like Stuart and Revett. Scholars, such as Winkelmann⁴⁰ were among the first to make scientific chronologies of the Greek temples which he considered to be more genuine since these temples were used as role models by the Romans⁴¹. Inspired by Winkelmann and Rome the author J. W. von Goethe was a pioneer when writing about heritage value in his novels⁴². His role figures discussed monument conservation and how mankind relates to history. Goethe's technical knowledge⁴³ made him advocate few interventions on built heritage and favour the preservation approach instead of restorations, in order to sustain the cultural value⁴⁴.

In 1792 the French Commission of Monument was compelled to put an end to the demolition of built heritage, subsequent to the French revolution, by establishing a decree on the protection of objects of certain values and artistic qualities. The very same commission had initially encouraged the destruction of the old hierarchic symbols by making such acts legal⁴⁵ but from now on such deeds were outlawed⁴⁶. The nationalisation of properties which previously had been in the possession of the king of France, feudal lords or the church meant these properties were now the responsibility of the Republic alone. For this reason the question of a legal framework became most urgent. To ensure the leading position of France, intellectuals were convinced that French heritage, from natural science to architecture, had to be preserved, and particularly so for educational purposes since it represented the accomplishment of man; from natural science to architecture⁴⁷. "*Barbarians and slaves detest knowledge and destroy works of art; free men love and conserve them*"⁴⁸, wrote the Bishop of Blois. He emphasised the value of heritage as time documents to be preserved as a whole, no matter their artistic style. However, despite all good intentions and legislative decrees, the built heritage continuously was demolished all over France. The classification, *Classement* of architectural heritage was implemented by the use of unifying measurements and a standardized language⁴⁹. The categorisation covered age, location, type of construction, decorations, technical condition or need for maintenance. Recommendations for possible future utilization as well had to be made for all buildings⁵⁰ as a proof the protected built heritage could be of public use⁵¹. Buildings with a *classment* certificate received a national protection and they were to be maintained by publicly employed architects and all conservation measures were to be funded by public means⁵². The revolution had also restructured the ruling classes in France and its new leaders; the generals and former

soldiers, favoured the ancient classicistic architecture which expressed their ideals of democracy; liberty, brotherhood and equality.

1800-1849. The spreading of published etchings illustrating Roman antique ruins, such as those by Piranesi⁵³, additionally encouraged this Neoclassicism. The illustrations inspired architects to new construction and re-buildings in this dominating style, all over Europe until the 1830's. Napoleon's occupation of Rome in the same way⁵⁴ helped to nourish this movement, but the drastic remodelling trend of historic buildings inspired by antiquity was not appreciated by all. The style was by some groups considered to be alien outside the Mediterranean region and this led to the revival of the medieval styles and historicism in the 19th Century. Architects like Pugin also underlined the importance of the relationship between the Gothic style and Christianity and hence likened classicism to heathen faith⁵⁵. Significant for the time was also the scientific approach taken prior to the commencement of restoration works, with studies being made of the ancient original drawings.

The close of the never completed medieval cathedral of Cologne by Boisserées⁵⁶ became the starting point for style restorations of national importance, which later were internationally adopted⁵⁷. Building conservation consequently became synonymous with the completion of the historic buildings where previous societies had failed. Numerous examples of historically inspired reconstructions⁵⁸ still stand as proofs of this political or nationalistic building restoration era. Important to note is that the movement's success was achievable due to the growing wealth among new classes in society thanks to the European industrialization⁵⁹. The quotation by Viollet-le-Duc⁶⁰ can signify as follows the era "*building conservation*"...(). "is.. not to maintain..but..to reconstruct a historical setting that might not even have existed"⁶¹

1850-1899. Parallel to the radical heritage reconstructions by le-Duc, and his British counterpart G. Scott⁶², the opinion condemning this "style purification" grew stronger in the 1850's. J. Ruskin⁶³ was among the first to publish his dislike of the purification. In his book "*The Seven Lamps of Architecture*" he argued that it was an impossible mission to restore the built heritage to its former glory and so he favoured the preservation stance and natural weathering⁶⁴. W. Morris⁶⁵ continued in 1877 "*It is for all these buildings, therefore, of all times and styles, that we plead....()*" resist all tampering with either the fabric or ornament..".⁶⁶

The Italian architect C. Boito⁶⁷ in the 1880's developed eight fundamental principles of interventions and systematic restoration approaches for the practitioners; *Primera Carta del Restauro*, to ensure the protection of authenticity and the documental value in historic buildings⁶⁸. According to Boito the historical

values were beyond the artistic or architecture ones and this was why all existing historic strata discerned during restoration works should remain visible⁶⁹.

1900-1909. Severe criticism from influential scholars and the general public, against the purification or style reconstructions, finally brought the historicizing refinements to an end by the turn of the century 1900. "*Save the monuments from the restorers*"⁷⁰ was the German art historian G. Dehio's comment on the new reconstruction plans on Heidelberg palace⁷¹. He again emphasized the symbol value in a historical monument but added that this lies in the eyes of the beholder. He said "*We don't conserve monuments because they are beautiful but because they signify the proof of our national existence..*"⁷²

Contemporary criticisms to Dehio's approach came from the Austrian art historian A. Riegle who proposed that values of built heritage touch the question of existence as well and for this reason built legacy could assist mankind in comprehending the relation between society and time. Superficial judgements limited to esthetical or historical judgements were simply not enough⁷³. Commissioned by the Austrian State⁷⁴ as general conservator Riegle was assigned to develop a check list of values to support the legal guidelines for protection of artistic- and historical monuments. Riegle's value classification was never intended to be a catalogue of characteristics,⁷⁵ since these features only remain on the surfaces, but an instrument indicating the religious, social and political dimensions of the built cultural heritage. *Art- and memory values*⁷⁶ of the built heritage had been sufficient for the value discussions in former times but insufficient for the 20th Century, according to Riegle, and were replaced by *Age value*⁷⁷; *Historical is every item that "once was and is no longer... (.)...can never be again... but forms a link in a chain of development"*⁷⁸. The artistic value is actually the same as the historical value but specified and distinctions are incorrect, said Riegle⁷⁹. To define the meaning of significance of built cultural heritage and monuments⁸⁰ Riegle uses the following two value categories; *Commemorative value and Present day value*⁸¹. The first refers to; age-, historic- and deliberate commemorative value. Age value⁸² is the fragmentary appearance which brings a patina and is easily understood by all. Historic value is the scholarly knowledge of skill and creation by mankind, which regrets especially the inescapable natural weathering of building materials⁸³. The final deliberate commemorative value will be unaffected by time⁸⁴. The second categories are the *Present day values*; *use value* and the *artistic value* and the latter also includes the *newness value* and *the relative artistic value*. The completeness in any modern creation is limited in time since it will be out of date at some point because nothing remains unaffected by climate decay. A historical monument will always be evaluated in relation to the modern buildings surrounding it and when this will eventually be replaced depends on society's value definition. The use value is left

unaffected, no matter the nature of maintenance, as long as this does not jeopardize the monument's existence. If the ecclesiastical or secular monuments in use are abandoned, they will be automatically replaced by others⁸⁵. *Artistic value* comprises the newness value and the relative artistic value. The Newness value⁸⁶ refers to what the monument never can return to; the completeness of newness is maintained if all traces, form or colour of age were removed. Style purifications in the 19th century, are a fusion of newness value and historical value and here all evidences of decay were removed, losses of fragment repaired and restored to a complete whole⁸⁷. The *relative artistic value*⁸⁸ finally is the art value of the uneducated majority and related to newness values. Old or fragmentary historic buildings are in this way considered ugly among these groups due to lack of insight, and for this reason are suggested to be replaced. Finally the relative art value can only be appreciated fully by those aesthetically educated and judged in relation to the initial purpose of the artistic object and hence require the expert's knowledge⁸⁹.

Value assessment of monuments by Riegel 1905					
Commemorative values			Present day values		
Value categories			Value categories		
Age	Historic	Deliberate commemorative	Use	Artistic	
				Newness	Relative artistic
<i>patina- all</i>	<i>knowledge</i>	<i>eternal present</i>	<i>non-use demolish</i>	<i>no patina</i>	<i>ugliness/laymen appreciate scholar</i>

Table 332.1 Riegel's value assessment of monuments from 1905.

1910-1918. M. Dvořák⁹⁰ stands as a contrast to his predecessors, with their often complex and mystifying or academic theories of values. His value characterisations on the contrary were easy presented as accessible guidelines for building conservation when they were published in 1916. The assignment of the heritage protection sector according to Dvořák, is to stop the restorations which will lead to unrecognizable results. He exemplified this line of thought through discouraging pictures of before and after situations, in his well illustrated publication; *Katechismus der Denkmalpflege*, from 1916. Industrialization makes mankind appreciate nature and historical environments more as a distraction from the ordinary weekday, said Dvořák⁹¹. The appreciation could either be of the art value of the build heritage, the environment that they create, the memory they awake or their patina. However, the most valuable message which is brought by the cultural heritage, says the author, is when their beholders experience the sense of belonging to time, with a past and a future. This notion any kind of historic

building may convey; from the simple cottage to the manor house, and so the four major threats to heritage must be defeated⁹².

1919-1949. Social upheaval and the new established nations⁹³ brought tensions and an unstable start to the 20th century in Europe. The two world wars that followed led to terrible losses of human lives as well as urban fabrics. To reach political stability the League of Nations was founded in 1919 to improve international cooperation. The intellectual co-operation branch later established an International Museums Office 1926⁹⁴ which put building conservation on the international agenda. The theoretical and practical issues surrounding building heritage have ever since been disputed at the regular conferences and the definition of value for the built legacy has been one of the major topics. The value concept proposals of importance were presented in some of the most influential resolutions and charters.

One of the first conferences ever arranged on architectural monument protection was held in Athens 1931. The subsequently published *Athens Charter* provided some new international guidelines on respectful conservation of authentic built heritage⁹⁵. Here the historical value as a criterion was merely mentioned which links this resolution back to the 19th century approach⁹⁶. The even greater losses succeeding the Second World War forced all war damaged nations to reconsider their previous guidelines of restoration when they were actually forced to reconstruct their vast areas of destroyed historic city centres. Inventories of damages led to a re-evaluation of built heritage based on the level of destruction⁹⁷.

1950-59. UNESCO and ICOM were established in the 1950's and experts, like C. Brandi, were assigned to participate in numerous international conservation projects. "*Restoration is generally understood as any kind of intervention that permits a product of human activity to recover its function*" wrote Brandi⁹⁸. However since this is not the main feature for a work of art the *potential unity* has to be re-established and this relates to the artistic value and to the whole as such. The artistic and the historic values form the core of restoration issues and what to give priority has to be established on every new occasion⁹⁹. "If we continue the analysis on terms of the historical point of view, we are faced with a double problem regarding works of art: the conservation or removal of additions"¹⁰⁰. Historical buildings, which Brandi considers is works of art, could not be considered ours from any practical aspects, such as utility value, but only based on their material, aesthetic and historical aspects¹⁰¹.

1960-69. After the UNESCO meeting had been held in Paris 1957¹⁰² the Italian Government adapted to the international trend as well and arranged a meeting

in Venice in 1964 on conservation of the built heritage¹⁰³. This conference initiated the writing of a resolution *The Venice Charter 1964*¹⁰⁴ which has influenced building conservation ever since. One expressed desire, in the document, is for instance that all historical buildings have a “socially useful purpose” without any altering measures needed¹⁰⁵. The aesthetic and historic values were to be protected just as original or authentic material as documents should be respected. For the first time it was recommended the new constructed additions made could “bear a contemporary stamp”¹⁰⁶ with the purpose of avoiding pastiches. Denmark was the only Scandinavian country which had a delegate participating at the meeting in Venice¹⁰⁷.

1970-79. To conclude the discussions held at *The International Symposium Budapest*¹⁰⁸ in 1972, this resolution reflected on reconstruction of war damaged city centres. Here the authenticity value was in focus, but all kinds of imitations it was suggested were to be avoided since these were considered to diminish the artistic and historical value of monuments. New uses and adaptations were generally recommended, as long as no internal or externally changes were made¹⁰⁹. *The Resolutions of the International Symposium Rothenburg* in 1975¹¹⁰ discussed how to sustain the historical towns. Classifications were presented according to size, cultural context and economic function. Financial activities can lead to emigration when they are too low or endanger the built environments when too intense, as by revitalizations. The resolution concluded that a balance between the building functions and the scale of existing urban fabric thus had to be reached¹¹¹. Their specific value definitions were; scale, appearance of streets and squares and empty buildings¹¹².

In October the same year the *European Charter of the Architectural Heritage*¹¹³ was coordinated by the initiator of the European Heritage Year, the Council of Europe. The meeting would be a springboard that initiated improvements of laws, education, financing and context integration of architectural heritage in all the member states. The spiritual, cultural, social and economic value in built heritage, which had been accumulated over centuries, was declared as irreplaceable resources that will be re-interpreted and inspirational for every generation to come¹¹⁴.

Subsequent to that year’s ICOMOS conference the *Declaration of Amsterdam 1975*¹¹⁵ was recognized by the member states. This meeting the “crowning event” of the European Architectural Heritage Year once concerned the protection of the common history of Europe which was said to be reflected in the priceless, but still present cultural value of built heritage. The funding must always be available for public and private bodies for heritage protection which unites the nations¹¹⁶. Conservation works on the built heritage may “economise resources” when ad-

aptations to new functions are made, according to the needs in society¹¹⁷. The capacity of the city planners plays a decisive role in distinguishing the aesthetic and cultural values of the historical heritage complexes¹¹⁸. They may not hesitate to suggest new activities in neglected city districts which can halt its ongoing deterioration¹¹⁹. Methods should be employed to engage people in general and information be made available¹²⁰. Apart from cultural values shall the use-value must also be tanked into account in conservation matters¹²¹.

1980-1989. The Mexican National Committee of ICOMOS drew up the *Declaration of Tlaxcala* in 1982¹²² and inspired by the earlier Trinidad conference the meeting once more defined foreign multi media as growing threats to the cultural heritage in small settlements. The negative influences on the local tradition were degrading the domestic value of heritage locally. The authorities were thus encouraged to make use of the media themselves for information campaigns and for re-gaining the local respect for heritage¹²³. The same year came *The Declaration of Dresden*¹²⁴ which analysed the reconstruction policy that had been used when restoring the symbolic value in the townscape. A great variety of tailor-made techniques had been practiced on the historic buildings destroyed by war¹²⁵. The spiritual value had increased parallel with the rate of progress in restorations on the demolished buildings. For this reason a resurrection called for a re-establishment of their traditional functions, at the same time as new social uses for the built heritage in a community were also suggested¹²⁶.

The former director at ICCROM¹²⁷ and practicing conservation architect; sir B. Feilden presented a new version on cultural property values. Under the three major headings; *Emotional values*, *Cultural values* and *Use values* with additional subdivisions the concept was designed to be of guidance to establish the cultural significance in cultural properties¹²⁸, (see table 332.2).

Value assessment of monuments by Feilden 1982		
Emotional values	Cultural values	Use values
a) wonder b) identity c) continuity d) spiritual & symbolic	a) documentary b) historic c) archaeological (age/scarcity) d) aesthetic & symbolic e) architectural f) town-,/landscape & ecological g) technological & scientific	a) functional b) economic c) social d) educational e) political & ethnic

Table 332.2 Value assessment of monument by Feilden 1982.

In The *Declaration of Rome* from 1983¹²⁹ the situation for building heritage in Italy was described as alarming due to “..the lack of available economic and financial resources”... caused by the communication insufficiency between practice, theory and politics. A qualification for professionals in the conservation field was called for since projects were often managed by unqualified professionals. Untrained contractors were taking on conservation projects whenever a financial decline in the new construction industry occurred¹³⁰.

Cultural significance was the leading motive in *The Burra Charter* 1988¹³¹ and referred to the “aesthetic, historic, scientific, social or spiritual value for past, present or future generations”. To improve work methodology the guidelines, identified by *cultural significance*, would be used for the evaluation of places, no matter size or type. The most important of the value criteria was their capacity to enrich the understanding of past times; this contributes to the present and could also be valuable in the future. *Aesthetic value* reflected its characteristics like form, scale or colour and *Historic value* indicated the history of aesthetics, science, society, historic figures or events. *Scientific value* referred to research value based on facts such as rarity, quality or representativeness. Finally *Social values* were the spiritual, the political, the national, the cultural or the sentimental ones.

1990-1999. The Danish National Board of Antiquities in 1991 arranged a Nordic seminar in Copenhagen concerning research and restoration of the built cultural heritage¹³². Among the lecturers discussing heritage values was J. Exner, a practicing architect in the field of building conservation in Denmark. Exner¹³³ discussed values first of all from the perspective of conservation practice. The reason why the interpretations of restoration work can be judged so differently, must relate to how the works are being valued, says Exner. The term *historical* can either be age, number of years passed, architecture style, its representative status and quality, historical event or a person. Since these criteria mean limitations in building categories to be considered, a search for definitions that could include all kinds of buildings of all times was therefore imperative. Exner suggested that “historical” must be defined as processes, where all dwellings are like actors in the course of events. A historical life turns all buildings into *living creatures*. They lead their life, but will constantly be manipulated by the course of time¹³⁴ completely independent of their original creators i.e. the architects or builders. The remoteness from genesis is inevitable and impossible to undo or impede, say Exner. Every building needs therefore to be respected as a part of an ongoing process visible as decay, patina, wear, weather resistance, rebuilding, extensions, maintenance and restorations. If one can grasp the process phenomenon, all dubious restoration works can be avoided, according to Exner.

The historical process, which promotes well-considered conservations, should define and respect these five key values; originality, authenticity, identity, narrative and reversibility. Originality means the content of original parts that always have to be less than 100% in heritage. Authenticity corresponds to the appearance of genuineness and is a result of the historical layers added over time. Identity is the individual character and nature that the edifice reflects, which once was attained, but still is viable. Narrative is the ability in a building to transmit history which is possible with maintained identity and authenticity. Reversibility relates to the demand on alterations being additions instead of subtractions where the option for recreations of the original setting still remains.

Value assessment of monuments by Exner 1991			
Originality	Authenticity	Identity	Narrative
>100%	historical strata	individuality	transmit history

Table 332.3 Value assessment of monument by Exner 1991.

*The New Zealand's Charter for the Conservation of Places of Cultural Heritage Value*¹³⁵ highlights that a nation is rich both in significant places as well as cultural heritage. The legacy relates to and is valued by its inhabitants and this inspired the local ICOMOS to arrange a conference in 1992. The aim was to draw up new guidelines on how to protect the individual existing values in landscapes, buildings, gardens, archaeological and traditional sites and sacred places. With few interventions¹³⁶, the compatible use and human activities can be the impetus to guarantee and make such places valuable from social, cultural and economical perspectives.

In *the Nara Document*, composed after the conference in Japan 1994¹³⁷ it was stated that when information on the existing values in the cultural heritage is convincing and accepted, concerning its characteristics, originality or meaning, this pure insight ought to be the driving force for conserving the legacy. Fixed criteria on general value judgements cannot be set up since they will only be applicable to an individual culture and must instead be established for each unique context. The authenticity value judgements can include the design, materials and substance, use and function, traditions and techniques as well as the spiritual experience. Further encouragements of the artistic, historic, social, and scientific values will give additional dimensions. It is fundamental to establish consensus on the existing values in cultural heritage through a multidisciplinary approach, declared the Nara Document.

“The authenticity of our cultural resources lies in the identification, evaluation and interpretation of their true values”, stated the *Declaration of San Antonio* 1996¹³⁸

which are the evolving driving forces. Authentic history is signified by sites which have been developed over time without value interference. Authenticity is also to be discussed in relation to material and social values. Contradictory to archaeological sites, that merely transmit the past, the built heritage needs to be used by society, thus adapted regularly and this will assure its sustainability. Authorities and owners are entitled to all knowledge available of the existing cultural values. The physical fabric in built heritage contains the intrinsic authenticity and the local communities contribute to their exterior values. Local and national revenue from tourism may be acceptable, but all reconstructions made to increase the income will finally be counter-productive since this will reduce the authenticity of the site.

The Stockholm Declaration 1998¹³⁹ coinciding with the Declaration of Human Rights 50th centenary, focused primarily on every human's right to and responsibility for cultural life. This entitles all individuals in society to have influence on decisions effecting heritage as well as "the cultural values it embodies". In order to reconcile preservation, equitable agreement between society, private sector and individuals ought to be made. The new *Swedish Cultural Protection Act*¹⁴⁰ in 1999 established a definition on value for built cultural heritage. The wide range of buildings, representing different times and functions, makes it unfeasible to establish a complete definition on culture historical value, it stated. According to the law, heritage value will always be a combination of different historical values such as; building-, technique-, architecture-, social and community historical values. All these could additionally be interpreted as scientifically ones.

The International Cultural Tourism Charter, established in Mexico 1999¹⁴¹ underlined that universal values in natural and cultural heritage belong to all and the specific collective memory needs further development. Six principles were developed in the charter as guidelines which define (1) tourism for culture exchange, (2) tourism that manages value conflicts sustainably, (3) tourism where sociable conservations is practiced, (4) tourism that involves indigenous regionally (5) tourism that retrieves income locally and (6) tourism in favour of the protection of the heritage.

2000-2005. In 2001 *Throsby*¹⁴² published a six levelled value concept to assess all sorts of cultural goods, from art work to built heritage. This multiple criteria approach denotes that a complete value survey could be established by the registration of the aesthetic-, spiritual-, social- historical-, symbolic- and authenticity values in cultural objects. The division of labour¹⁴³ shows that these judgements require the collaboration of different professional groups.

Value assessment of monuments by Throsby 2001	
Value units	Work division
aesthetic	mapping
spiritual	thick description
social	attitudinal analysis
historical	content Analysis
symbolic	expert appraisal
authenticity	

Table 332.4. Value assessment of monument by Throsby.

The *Culture historical characterization and appraisal of churches* from 2002¹⁴⁴ represents the Swedish value inventory guidelines, which were set up as a result of the division of the national church from the state in 2000. The heritage authorities at the Swedish National Heritage Board (RAÄ) for this reason developed manuals for church inventories which were aimed at obtaining a complete overview of the national church assets and their condition. The matter was considered most urgent as the responsibility for the sacred legacy from now on was the parish's own. Substantial public subsidies¹⁴⁵ made it possible to launch this large scale church registration and the listing of their values, was consequently most essential. The evaluation manual characterizes two main value groups; the *general* or the *individual*. The general relate to those which are general for all church building such as; symbol-, continuity- or landmark value¹⁴⁶ and these should not be specified in the reports. Instead the individual values which are unique for the church itself are to be registered and defined as historical values involving style, construction, brickwork, building phases or the interior design.

After *Victoria Falls, Zimbabwe 2003*¹⁴⁷ the written recommendations conveyed that all parties have to be involved in the protection of cultural heritage. The built heritage sites and the surroundings need to be considered as a whole if we are to respect individual cultures and for this reason no value or authenticity criteria can ever be predetermined. The built heritage values concerns the complete buildings, exterior as well as interior and all removals will always diminish the authenticity. The value of concept-, techniques and historical evidence were the future values to protect, concluded the conference.

The Swedish *Culture historical evaluation of buildings*¹⁴⁸ was proposed the same year by the heritage authorities¹⁴⁹ on commission by the government. This framework for heritage values was intended to establish the ambition of protective and legislative measures necessary for secular buildings. The identification of values in the manual was defined in accordance to a checklist which was subdividing the value characterization in two parts; the *documentary value* and the *experience value*. The documentary value described the more tangible or objective and quantitative values such as the building historical-, building technological- or social

historical values¹⁵⁰. On the other hand, the experience values were to register the intangible or qualitative criteria involving such as the identity, artistic or symbol values¹⁵¹.

Value assessment of monuments by Unnerbäck 2003	
Documentary value	Experience value
building historical	architectonic
building technique historical	artistic
patina	patina
Architecture historical	environmental/contextual
society historical	identity
social historical	tradition
Person historical	symbol
technique historical	

Table 332.5 Value assessment of monument by Unnerbäck 2003.

On the *Framework Convention on the Values of Cultural Heritage for Society* held in Faro 2005¹⁵² the definition of value was discussed in order to establish methods for possible value enhancements and the capacity that the built environment has to contribute to society. The skilled maintenance based on original building techniques was essential in making the built heritage resourceful, even for local economical development. Value growth could be achieved by an improved accessibility for all and dissemination of information through digital technologies to reach young people as well. In the local “*heritage community*” unique values characterizations can evolve, since these are affected by previous conflicts.

The *Xi'an Declaration* in China 2005¹⁵³ defined the essential object- and cultural values to be defined as the social, spiritual, historic, artistic, aesthetic, natural, scientific values and how they relate to the context of the built environment.

2006-2008. The recent *Declaration of Foz do Iguaçu* in May 2008¹⁵⁴ discussed the significance of “*spirit of place*” which was characterized as an interaction between the material, such as the building and the intangible nature or manmade settings. To recognize what could be defined as the spirit of place, then the identity in a community must also be sustained and even transmitted from one generation to the other. “*The value system and the social practices of communities be understood and respected as part of the spirit of the place*”¹⁵⁵. Moreover, if one aims to ensure the social development of spirit of the place, consequently the tangible as well as the intangible heritage has to be preserved, for instance routes, memories and written documents.

The *Quebec Declaration on the preservation of the spirit of place* in 2008, also examines the subject¹⁵⁶. The tangible value was here said to be related to build-

ings but rituals were defined as intangible heritage value criteria. The two value categories suggested may create a whole and interact. The definitions can be more adaptable to the globalized society since they promote the interaction between cultures. The strategic plans which are required to secure the spirit of places will always have to be modified since this depends on the vitality of memory, the declaration concluded. Cities like Jerusalem have several “spirits” since it is interpreted by many religious groups and “*communication is the best tool for keeping the spirit of place alive*”⁵⁷

To sum up this theoretical outline describes the milestones of value concepts applied, Goethe was among the first to initiate the heritage value discussion which the reproduced antique literature had once begun (see table 332.6). The Classements introduced a national legal framework based on a strict assessment and the internationalization of building protection in the 20th century strived for a unified value concept. These written sources, from recommendations to charters, reveal the ambition to create a solid protection for built heritage by referring to its irreplaceable qualities. In spite of this good intention though, these value definitions have not always proved to be convincing enough to prevent losses, even defined in legal protection acts. The only actual proofs we have of the heritage value efficiency, are the remaining built cultural heritage of today. For this reason, in order to establish a viable value concept, both theory and practice might have to be employed.

Value	H.UNS	specified	Value definitions applied in the past	Initiators
H ₁	historic	quality	cultural value, spiritual, social-, event- personal-, relationship-, contextual-, historical-, documental-, anthropological-, traditional-, familiarity- age-, authenticity-, intangible value	Goethe, Classements, Pugin, Morris Boitio, Dehio, Riegel, Dvorák, Brandi, Venice, Budapest, CoE, Tlaxcala Feilden, Burra, Exner, Nara, San Antonio, Stockholm, Mexico, Unnerbäck, Faro, Xi'an, Foz, Quibec
H ₂	historic	knowledge	scientific value, conceptual, form-, decorative-, style, aesthetic-, architectural-, knowledge-, artistic value	Winkelmann, Boisserées, Vollet-le-Duc, Scott, Riegel, Athens, Brandi, Venice, Feilden, Burra, Nara, Sweden, Unnerbäck, Xi'an
H ₃	historic	quantity	construction-, authenticity (surface)-, original-, quality of craftsmanship-, reversibilit, condition-, originality value	Goethe, Ruskin, Morris, Boito, Dehio, Riegel, San Antonio, Dvorak, Brandi, Venice, Budapest, Tlaxcala, Feilden, Burra, Exner, Nara, Zimbabwe, RAA, Faro
U	utility		use, adaptability, tourism pedagogical value	Classment, Riegle, Brandi, Venice Budapest, Council of Europe Rothenburg, Amsterdam, Dresden, Feilden, New Zealand, Nara, S. Antonio, Mexico, Unnerbäck, Faro
N	nominal		economical recourses, -assets, economical aspects	Rothenburg, Council of Europe Amsterdam, Tlaxcala, Feilden Rome New Zealand, Mexico and Faro
S	symbol		national greatness, landmark,	Grégoir, Dehio, Dresden, Feilden

Table 332.6 Value definitions used in the past, based on the H₃UNS concept.

3.3.3 New value concept by H₃UNS

The intention of the chronological outline of theoretical value concepts, from written sources, was to examine how these would coincide with the HUNS concept of Study 1, which was based on the definitions utilized in practice¹⁵⁸. If conformity could be verified the value scale might exemplify a more inclusive and complete value concept for built heritage, since it is rooted both in practice and theory.

The most common definition in evaluations when assessing built heritage was always the *Historical value*, which traditionally also used to be the key unit for the legal protection framework; the legal value (LV). This frequent and broad usage has thus made the term “historical” indistinct. For this reason one objective was to subdivide the variety of definitions discussed in the outline and instead search for possible enclosed patterns and a specific definition of the *historical value* expression. The analysis of how it had been applied in the literary outline showed that three variations of the expression could be discerned. These can be exemplified by the following authors; Goethe writes about historic value so that this phenomenon in built heritage assists man in sensing history. Winkelman’s¹⁵⁹ appreciation of this value unit lies in the detailed knowledge of the Greek architecture. Dvorák, finally demonstrates how historic value will be lost when monuments are restored according to style purification at the expense of originality. Goethe is referring to the subconscious link between built heritage, man and history, or the intangible values thus describing the *Historic Quality Value* (H₁) in this study. Winkelman on the other hand is the scholarly interpreter of historical values accessible through scientific studies of heritage or the *Historic Knowledge Value* (H₂). The more intense a field of knowledge becomes the more affectionately involved even an academic approach to ancient constructions will grow. Dvorák’s distinct visualisations of the brutally restored buildings were intended to induce public opinion against the negative impact of style restorations and so he extracted the most tangible value sign of the historic aging because it refers to the surfaces¹⁶⁰ here called the *Historic Quantity Value* (H₃). The last value unit relates as well to Coeterier (Coeterier 2001) and Ipekoglu (Ipekoglu 2004) studies, judging values by analysing facades and these proved to be the most accessible evaluation unit among laymen¹⁶¹.

Value concept in the past						
Time	Values H ₃ UNS					
Century	H ₁	H ₂	H ₃	U	N	S
1400-1749						
1750-1799						
1800-1849						
1850-1899						
1900-1909						
1910-1918 W W 1						
1919-1949 W W 2						
1950-1959						
1960-1969						
1970-1979						
1980-1989						
1990-1999						
2000-2005						
2006-2010						

Table 333.1 Value development over time; Chronological overview of H₃UNS value concepts development.

Table 333.1 illustrates how the value units have been expressed over time and the individual value progress has also been studied in relation to the theoretical outline for further elucidation in this section.

H₁; The Historic Quality Value reveals no distinct time cycles in the written overview as the assessment has always been vital. Goethe but also Pugin, Ruskin and charts¹⁶² emphasize its importance. The unit refers to the built heritage's qualitative ability to transmit the past to our senses. It confirms that that today's society can only represent the contemporary perspective between times passed and the future to come. The value concepts indicating this unit in the historical overview were; *cultural value, spiritual, social-, event-, personal-, relationship-, contextual-, historical-, documental-, anthropological-, traditional-, familiarity-, age- and intangible value.*

H₂; Historic Knowledge Value seems to be less discussed at times and was introduced as archaeology seized its scientific position during the 19th century. Other than Winkelmann, the value advocators have been the devotees of the style purification movement such as the Boisserée brothers, Vollet-le-Duc or Scott¹⁶³. The value illustrates the scholarly or theoretically attained appreciation of monuments expressed in specific styles, being an architectural role model or signs of artistic performance in architecture or decorations. This value was identified in the outline with expressions like; *scientific value, conceptual, form-, decorative-, style, aesthetic-, architectural-, knowledge- and artistic value.*

H₃; Historic Quantity Value is the third and final historical unit which has also been less in focus from one era to another, especially in the post war pe-

riod. Dvorrák efficiently practices this tangible historic value against the large-scale restorations which also was referred to in the Classement¹⁶⁴. The assessment represents the surface authenticity which is available for all in society to judge. It regards the amount of genuine or original fabric, constructions or building material still present in historic buildings. The outlined value concepts identifying this value group were; *construction value, authenticity (surface)-, original-, quality of craftsmanship-, reversibility-, condition- and originality value*¹⁶⁵.

U; Utility Value is registered as being respected ever since the fall of the Roman Empire. The Catholic Church and the inhabitants of Rome saw the worth of Roman architecture for functionality or as the embodied energy stored in the building material¹⁶⁶. The intention was never to protect the heritage in situ, only to recycle. The Classments¹⁶⁷ was then among the first heritage acts to practice the value unit for protective reasons, but was later followed by Riegler and others¹⁶⁸. The concepts applied for the unit over time were; *use, adaptability, tourism and pedagogical value*. The re-use of built legacy came especially into focus during the 20th century. The utility value can provide a protection for the heritage thus enabling this to be profitable and thus to sustain. Restrictions in utilization, restraining adaptation might be counterproductive to the intentions¹⁶⁹. All alterations and adaptations whenever performed must begin with detailed planning analyses, to avoid any technical and intellectual value decline.

N; Nominal Value in built heritage seems to be of a later date and first to be discerned as a unit during the European Heritage Year and was first mentioned in Rothenburg, followed by the Council of Europe both in 1975¹⁷⁰. The concepts linked to the unit were; *economical recourses and finance assets or aspects*. The nominal value reflects the finance investments which are considered invested in built cultural heritage but mirrors also the possible revenues or marginal output of funding. The value ascends subsequent to all forms of building conservations¹⁷¹ and new investments are made, but will descend if built heritage is exposed to neglected or inapt conducts which may generate unexpected maintenance costs. Sudden demolition, such as fire, unprofessional craftsmanship, insufficient or incompetent technical solutions and others measures all leading to new damages again make the nominal value drop.

S; Symbol Value is among the least discussed value unit in literature. The bishop of Blois seems to be one of the first to introduce symbol value when he was referring to how the former glorious France was about to vanish due to the heritage destructions after the revolution. The style purifications were the political symbols used for promoting new nations like Germany in the late 19th century, but also emphasised by for instance Dehio¹⁷². The concepts linked to the unit were; *national greatness, landmark*. To focus on the symbolical value is to interpret built heritage primarily through the contemporary political, religious and

social perspectives. The symbol value induces strong positive or negative feelings which can develop into either demolitions or costly reconstructions¹⁷³. Its ability to enhance nationalistic feelings makes this unit endanger monuments in political conflicts.

The comparison of the empirically based value scale to the chronological outline of the value in theory, proved to be compatible. For full confirmation however adjustment was necessary concerning the historical value units. The previous imprecise definition in this way became more distinct when subdivided according to the literature findings in three entities of Historic Quality Value (H_1), Historic Knowledge Value (H_2) and Historic Quantity Value (H_3). Table 333.1, which finally summarises the new six value units of H_3 UNS illustrates 600 years of value concept development. The historic quality value proved to be the most discussed value concept of all¹⁷⁴, the historic quantity values followed and the historic knowledge was the least mentioned. The utility value seems to be ascending over time and so contradicted the descending symbol value. Nominal value finally was the most recent value unit when established in the 1970's. These fluctuations of values registered in the outline most likely have had an impact on how built cultural heritage has been respected chronologically, as exemplified in the Maglarp-Allhelgona case. This once more indicates the existence of and the need to explore the accelerators of values further.

Values H_3 UNS	
H_1	Historic quality value
H_2	Historic knowledge value
H_3	Historic quantity value
U	Utility value
N	Nominal value
S	Symbol value

Table 333.2 The six value units of H_3 UNS concept.

3.3.4 The value units' relations to accelerators

The chronology, which is illustrating the praxis to define the significance of built environments, in relation to the H_3 UNS concept, fluctuates since external circumstances will enhance some value virtues more at times. These variations are most likely the outcome and influence of *actions* taking place in society, with the ability to initiate a movement where built heritage is respected for new and

changing qualities or values. The human conception which, on the other hand, registers these changes is here identified as the *accelerators* (A). These can encourage whole societies to perceive values in the built cultural heritage and so induce to behaviours favourable for its protection. The accelerator thus transmits the contact to specified values, through action units, only randomly or else no cyclical value development would occur. The progressing society will constantly alter the external conditions for man and his creations. This is why some historic buildings become more agreeable while others temporarily fall into neglect¹⁷⁵.

In order to understand how actions stimulate accelerators to induce to the perception of values, the individual value units of the H_3 UNS need to be further scrutinized concerning their unifying as well as their diverging features. To begin with the clustered expression of historic value the *quality* (H_1) units refers to the built heritage's ability to transmit the past to our senses and the *knowledge* H_2 illustrates the scholarly or experts dialogue with and appreciation of facts in details. The historic *quantity* H_3 unit refers to the surfaces of decorations or structure; in contradiction to the others it is an assessment and more within reach for all to discuss.

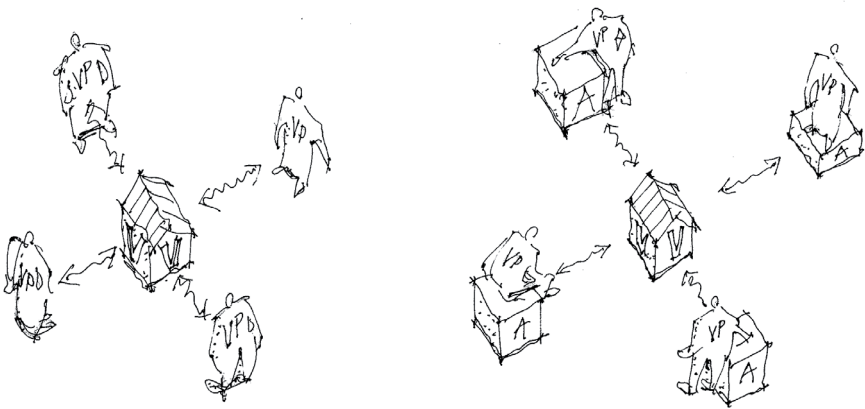

334.1 To perceive Value is an individual process (left). Ones own Value preference (VP) is induced by a unique set of accelerators to perceive value in a building.

The historic quality and knowledge value, $H_{1,2}$, therefore can be described as intangible value definitions and in contrast to the historic quantity H_3 value, which neither requires deep affection nor profound studies to be applied. The historic values in other words represent different groups. The first two engage more sentiment and can so be said to be initiated by *emotional accelerators*, thus these are called group 1. The more easily reached H_3 concerns the obvious surface characteristics and is hence to be sorted under another more rational group.

H ₃ UNS value units				
Accelerators	Rational	Sentiments	Law	Groups
Emotional		H ₁ , H ₂		I

Table 334.2 Emotional accelerators initiate value units engaging sentiments.

The utility value (U) refers to the profitable outcome opportunities in built heritage and the nominal value (N) revealing the financial investment or revenues. Consequently they represent as well rational assessments of heritage. The historic quantity value H₃, judging countable surface structures on facades can allow pecuniary worth to be set, even by laymen as well. This capacity of the historic quantity value, of promoting financial awareness, explains that the Utility, Nominal and the Historic quantity values of group 2 are all induced by *financial accelerators*.

H ₃ UNS value units				
Accelerators	Rational	Sentiments	Law	Groups
Emotional		H ₁ , H ₂		I
Financial	H ₃ , U, N			II

Table 334.3 Financial accelerators initiate rational value units.

The symbol value (S) which is judging built heritage, based on political, religious or social filters, cannot be sorted into any of the others; thus is group 3, since it is hardly induced by emotional or financial accelerators. This unit constitutes a separate third group since the value objective is reflecting strong but totally unpredictable outcomes for built heritage and hence this unit is induced by *political accelerators*. The symbol value is thus unable to establish reliable value stabilization which could induce behaviours favourable for heritage protection.

H ₃ UNS value units				
Accelerators	Rational	Sentiments	Law	Groups
Emotional		H ₁ , H ₂		I
Financial	H ₃ , U, N			II
Political				III

Table 334.4 Political accelerators initiate the symbol value unit.

As discussed; France introduced a new form of legal protection, the Classements 1790, to prevent further demolition and ensure the endurance of their built heritage. Legal protective measures were also established decades later in most

European nations and all were based on the exclusive value definitions, legal value (LV). The urge to protect built cultural heritage with a legal framework was neither encouraged due to emotional, nor for financial reasons but out of a duty-bound national conviction and can for this reason be said to be encouraged by the *obligation accelerators* (OA). Since the spirit of the age in society always influenced the value norms, it represents the legal value the institutionalized and static time bound assessments of group 4. The obligation accelerator can never raise the value of built heritage; only strengthen the regulatory framework of law protection.

H ₃ UNS value units				
Accelerators	Rational	Sentiment	Law	Groups
Emotional		H ₁ , H ₂		I
Financial	H ₃ , U, N			II
Political	S			III
Obligation			LV	IV

Table 334.5 The suggested relation linking accelerators to individual H₃UNS units, due to their common features, into four groups.

Unifying features of the value units in the H₃UNS concept, structure these into specific relations with the accelerators. This entails that the value units, of the H₃UNS concept, in changing intensity in time, are induced by either; emotional accelerators (EA), financial accelerators (FA) or political accelerators (PA) of group 1-3, see table 334.5. The static equivalence; the legal value (LV) and its regulatory framework, is induced by the obligation accelerator (OA) and constitutes group four.

Out of the four accelerators discussed only the emotional (EA) and the financial (FA) ones can stabilize, thus enhance values in built heritage. This perception of values could encourage behaviours in society favourable for its protection such as heritage funding.

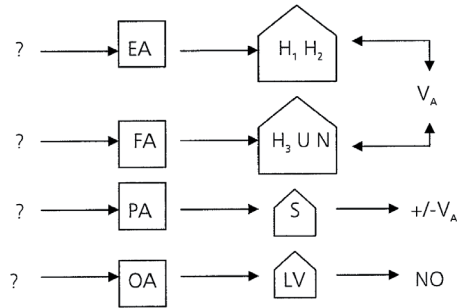

Figure 334.6 The suggested relation of accelerators linked to value unit groups. Emotional and financial accelerators alone affect the value activating funding (V_A).

Accelerators (A) enhance the perception of selected values based on the H_3 UNS concept
 A+VP

A= emotional accelerators (EA) or financial accelerators (FA)

Value activate to economic behaviour, when the value activating funding is sufficient (V_A) which is favourable for heritage protection;

The acquiring of funding
 $A+VP = V_A$

3.3.5 The funding mechanisms; Actions stimulate accelerators of man to perceive values in sites

Accelerators' capacity to make generations and cultures see values in built culture heritage are results of the influence or stimulation that the external actions have. These regularly occur in contextual setting of the heritage sites, which time after time through history have stimulated man to an economic behaviour favourable for the built heritage's protection¹⁷⁶.

To clarify the idea of the effect that certain actions, through the accelerators, may have on particular values, the assumed relationship between actions, accelerators and values; *the mechanism of funding*, has thus in this dissertation been exemplified by three historical events; France 1790, The Venice charter 1964 and European Heritage Year 1975.

The values based on the H_3 UNS concept, which are revealed will so signify the unique period of time, when the actions took place and so match the value preference (VP) in society of time; the spirit of the times. However, the value preference

expression will from now on in this study signify the personal “value condition” of financiers.

1. France 1790

The destruction (1) of properties in France after 1789, induced by the new political ideology (2) among the suppressed and starving population who now regarded some built heritage as representing a detested hierarchical society (2). This situation spread the feeling of threat (3), the fear of losing the built cultural heritage for ever. Intellectuals became involved in and committed to sustaining the monuments, which is why a legal protection Classement (6) was established. The legislation tried to cover everything from the monuments’ decorative surfaces to the practical use (4) and as a protective measure, for the historic buildings to have public access (5).

Actions	Accelerators	H ₁ UNS Value/VP	Legal value
1. Threat	Emotional (EA)	Historic quality value (H ₁)	Legal framework
2. Ideology (Socialism)	Political (PA)	Symbol value (S)	
3. Threat	Emotional (EA)	Historic quality value (H ₁)	
4. Finance growth (a/e)	Financial (FA)	Utility value (U)	
5. Access	Emotional (EA)	Historic quality value (H ₁)	
6. Duty	Obligation (OA)		

A= EA, emotional accelerator of value initiated by actions of threat and access
 FA, financial accelerator of value initiated by actions of (a/e) finance growth
 PA, political accelerator of unreliable, not value enhancing for built cultural heritage
 OA, Obligation accelerator of legal value, not value enhancing for built cultural heritage
 VP= Value preference France 1790; sentimental and rational H₁, U, S
 V_A = Value activating to economic behaviour favourable for the built cultural heritage

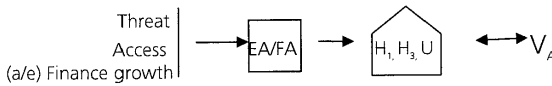

Figure 335.1 Action-Accelerator-Value (VP=V_A) in France 1790.

The social upheaval in the 1790’s initiated the spirit of the times in people; sentimental and rational value preference (VP) of H₁US, by six actions stimulating four accelerators. Threat and access now stimulated the emotional accelerators just as the actual and expected finance growth did the financial ones.

Ideological action encouraged political accelerators, in the same way as the duty action did the obligation accelerator. However, in the both last cases still without enhancing the value of the built heritage.

2. The Venice charter 1964

The conference and the Venice Charter provided many stakeholders with good advice, experiences and tools (1), by spreading information internationally (2)

about heritage protection. This encouraged nations to suggest scientific studies, for attaining new facts (1) and furthermore to make use (3) of the built cultural heritage, in order to save its significance.

Actions	Accelerators	H ₂ UNESCO Value/VP	Legal value
1. Information	Emotional (EA)	Historic quality value (H ₁)	
2. Access	Emotional (EA)	Historic quality value (H ₁)	
3. Finance growth (a/e)	Financial (FA)	Utility value (U)	

A= EA, emotional accelerator of value initiated by actions of information and access
 FA, financial accelerator of value initiated by actions of growth
 VP= Value preference European Heritage Year 1975; sentimental and rational H₁U
 V_A = Value activating to preservation



Figure 335.2 Action-Accelerator-Value (VP=V_A) in time of the Venice charter.

The Venice Charter initiated the spirit of the times; sentimental and rational value preference (VP) of H₁ H₂ U, by four actions stimulating two accelerators. Information and access at this time stimulated the emotional accelerators just as the actual and expected finance growth did financial accelerators.

3. European Heritage Year 1975

The international conferences arranged during the European Heritage Year in many different countries that year, offered the source of information (1) to engage nations globally (2) and in the future to respect the built cultural heritage as an asset for cultural tourism (3) to make use of it in order to afford protecting its significance.

Actions	Accelerators	H ₂ UNESCO Value/VP	Legal value
1. Information	Emotional (EA)	Historic quality value (H ₁)	
2. Access	Emotional (EA)	Historic quality value (H ₁)	
3. Finance growth (a/e)	Financial (FA)	Utility value (U)	

A= EA, emotional accelerator of value initiated by actions of information and access
 FA, financial accelerator of value initiated by actions of growth
 VP= Value preference European Heritage Year 1975; sentimental and rational H₁U
 V_A = Value activating to preservation



Figure 335.3 Action-Accelerator-Value (VP=V_A) during the European Heritage Year

The European Heritage Year 1975 initiated the spirit of the times among people; sentimental and rational H_1 U value preference (VP), by three actions stimulating two accelerators. Information and access in the mid 1970's stimulated the emotional accelerators just as the actual and expected finance growth did financial accelerators.

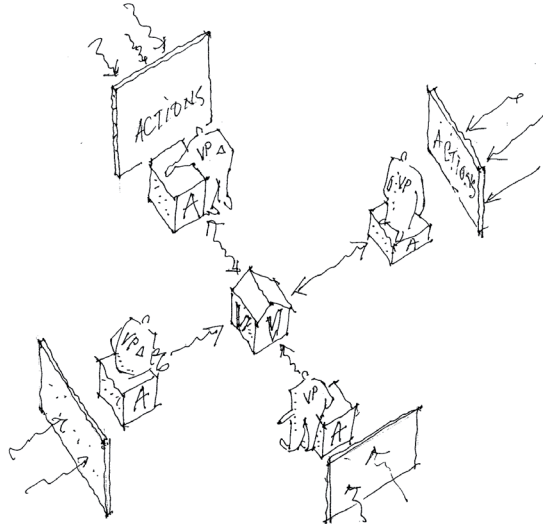

Figure 335.4 Illustration of the mechanism of funding action-accelerator-value.

The three examples from the chronological overview disclosed the correlation between actions, accelerators and values, that is; how people could have experienced the condition at the time, which was why they took certain measures.

The time periods initiated seven actions correlating to four accelerators¹⁷⁷. The *information- access-*, *threat* actions stimulated the emotional accelerator while *finance growth* inspired the financial and can either be *actual- or expected finance* growth.

The political accelerator referred to *ideology* and the obligation accelerators to the *duty* action. Since both political and obligation accelerators fail to increase the heritage value in built environments, only the existence or presence of emotional and the financial accelerators among potential financiers become the most relevant to disclose.

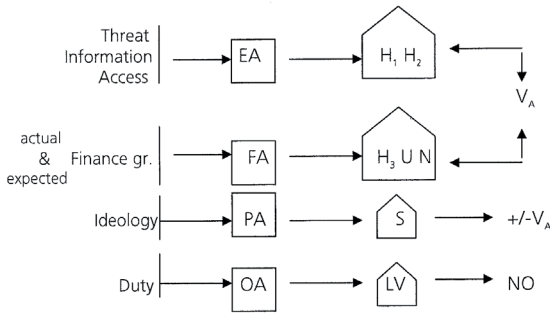

Figure 335.5 The suggested relation of how actions are linked to accelerators and value unit groups. Actions of ideology and duty can not induce a reliable positive effect on the value activating funding (V_A).

Actions	Accelerators	H ₃ UNS value concept	
		Rational	Sentiment
Treat Information Access	Emotional		H1 H2
Actual & Finance growth Expected	Financial	H3, U, N	

Table 335.6 The suggested relation of how actions-accelerators-values could be linked.

Because values applied for judging characteristics in historic buildings are generally accepted, but temporary interpretations, reflecting a notion of monuments permanent characteristics, neither durable legal protection nor price tags can be set on it for the future. Only rear-view mirror judgements of monument value can be proposed with certainty¹⁷⁸ as to how mankind once evaluated monuments. Changes in society will influence the human awareness at all times.

Value acceptances' unpredictable character becomes most evident during social upheavals in societies and this, the built cultural heritage in Poland, Lithuania or former East Germany certainly has verified. The disrespect for building heritage which then could develop among people proves the strong influence of actions, such as the effect which the nationalisation of all private goods after 1945 had. These alterations of external conditions hence directed new heritage values of buildings from one year to the other.

Establishing value stability will therefore entail taking control over the accelerators, which are inducing people to perceive values, by promoting the right basic actions. The accelerators might become effective instruments for inducing economic behaviour favourable for protection of built cultural heritage, such as

heritage funding. However, first of all, the likely financier’s individual value preferences, based on the H₃UNS concept, need to be revealed.

3.4 Comparative tests of the H₃UNS concept

With the attempt to validate the H₃UNS concept further, in relating to other applied multi criteria value theories in use, the concept has in the last sections been further tested. First against other official value classifications, secondly on the equivalent research front and thirdly, by three user groups.

3.4.1 Value classifications; Riegel, Feilden, Exner, Throsby and Unnerbäck

In order to see the relevance, capacity and scope of the H₃UNS concept this has been analysed here in relation to five equivalent value theory concepts, named after their originators. All concepts represent the multiple criteria method, which is signified by the fact that no numeral measurements are applied¹⁷⁹. In the already discussed chronological outline above, these concepts have been illustrated in tables according to their original classification structure, as discussed under paragraph 3.3 above. To become compatible this time, the concepts by Riegel, Feilden, Exner, Throsby and Unnerbäck have been reorganized but in a sequence which corresponds to the H₃UNS structure (see table 341.1).

Comparative analyses of value assessments					
H ₃ UNS	Riegel	Feilden	Exner	Thorsby	Unnerbäck
H ₁	newness relative artistic	wonder identity continuity documentary archaeological social	authenticity identity narrative	spiritual historical social	building historical patina, society historical social- and person historical environmental identity, patina continuity, tradition
H ₂	historic	scientific		aesthetic	architecture history technique historical architectonic, artistic
H ₃	age	technological	Originality	authenticity	building technique historical patina/trace
U	use	functional educational			
N	non-use	economic			
S	deliberate commem.	spiritual & symbolic political & ethnic		symbol	symbol

Table 341.1 Comparative analyse of H₃UNS to the value assessments of Riegel, Feilden, Exner, Unnerbäck, Throsby.

Riegl's value classification from 1905 was established based on the *Commemorative- and Present day values* units. These were legal guidelines for Austrian building protection where he was the general conservator. The comparison of these values concepts to the H₃UNS shows that all units are in congruence, but of nominal value. Riegl's assumption on non-use concerns the value loss and so indirectly the nominal value as well. *Feilden*, conservation architect in practice and director of ICCROM, published the value scale for historic buildings in 1982. The major headings focuses on the *emotional, cultural and use values*. Nonetheless, in comparison this structure is in complete unity with the H₃UNS concept.

Conservation architect *Exner's* value system from 1991 reveals many differences in comparison to the H₃UNS concept. The concept is not systemized in groups and the four entities described for this reason have to be individually judged. The model is in comparison the least compatible of all concepts analyzed, since it only discusses the historical quality (H₁) and quantity (H₃) values. The *Throsby* value concept from 2001 is the only classification published by a culture economist. The assessment form refers to all cultural goods from art work to built heritage, the six levelled scale lacks headings and they are individually evaluated. The Swedish National board of antiquities in 2003 published the value concept designed by *Unnerbäck*. The checklist is composed of two parts; *the documentary value* and the *experience value*. Although a vast number of descriptive characteristics are employed, still neither use- nor the nominal values are included in the model.

The comparative study revealed that two of the five tested value scales, Riegl and Feilden, coincided with the H₃UNS concept. These are also composed according to value inclusion and the outcome also verifies the H₃UNS concept. Value scales are sometimes considered to reflect professional background of the inventor, but this could not be observed. For example the art historians; Riegl and Unnerbäck have much diverging value classification just as the architects Feilden and Exner do. This may indicate that it is rather a reflection of the individual attitude to and competence in building conservation practice which matters. Noteworthy is however that the historic qualitative (H₁) value has again been stressed in all models, a fact which could also be observed in the value concept outline¹⁸⁰.

3.4.2 The current research front on built cultural heritage values

The definition of value, as earlier discussed, might be to quantify goods in the sense of measuring, that is rating or ranking, but it could also be distinguished as a quality or property of objects.

The earliest studies for establishing a scientific value of monuments began as early as in the 1950's in the U.S. and even then concerned the nominal value or pecuniary worth. The oil crisis in 1975 again focused on the energy saving aspects of protecting the built legacy, but then also included usability. The new approach within culture economics developed from the 1970's and articles were published in the newly established *The Journal of Cultural Economics*. After the year 2000 culture economy gains acceptance within the heritage sector, through pioneers like Thorsby active within ICOMOS in Australia and in Rome. Studies based on historic quantity values have also been performed during the last decade revealing the communicative capacity of monuments among laymen.

Value H _{UN} S		Definition	Value definitions over time	Research on value of historic buildings
H1	historic	quality	<i>cultural value, spiritual, social-, event-personal-, relationship-, contextual-, historical-, documental-, anthropological-, traditional-, familiarity-age-, authenticity-, intangible value</i>	
H2	historic	knowledge	<i>scientific value, conceptual, form-, decoration/style, aesthetic, person, decorative-, style, aesthetic-, architectural-, knowledge-, artistic value</i>	
H3	historic	quantity	<i>construction-, authenticity (surface)-, original-, quality of craftsmanship-, reversibility, condition-, originality value</i>	Coeterier 2001 Ipekoglu 2004
U	utility		<i>use, adaptability, tourism pedagogical value</i>	Alexander 1975
N	nominal		<i>economical recourses, -assets, economical aspects</i>	Hotelling 1949 Clawson 1959 Wees 1976 Stein 1977 Thorsby 2001 Herrero and Sanz 2002 Ruijgrok 2005 Hutter and Thorsby 2008 Peacock and Rizzo 2008
S	symbol		<i>national greatness, landmark,</i>	

Table 342.1 The research front concerning built cultural heritage values is dominated by finding forms to set the nominal value.

Table 342.1 illustrates a selection of the research field that analyses value concepts of built cultural heritage, with a dominance of studies developing tools for monetary quantification or the nominal value. The studies analyse the built heritage such as; unit of energy, embodied energy, Travel Costs Method (TCM) , Contingent Valuation Methodology (CVM) Cost-Benefit Analysis, (CBA). Yet, as observed in the value concept outline above, and emphasized in all value concept models, it is of major importance to establish the historic qualitative (H₁). The predicament is that its characteristics are intangible and so qualitative. The

reason for assessing the nominal value could be to compensate for the inability to reach the innumerable value entities, and in this way ensuring protection of built heritage. The effect of the new approach, in spite of its limitations to nominal value, most likely can motivate new groups, such as politicians, to start discussing built heritage when first introduced, based on financial grounds.

Since the conjecture, in this inquiry, is that values are ceaselessly present in historic buildings the now proposed value concept is only to be utilized for revealing the mechanism behind heritage funding. *Measurements* of the value levels per se for this reason become irrelevant. This standard template of H₃UNS is to be considered as an instrument which enables communication and analysis of the mechanisms of heritage funding, in relation to the value preferences of today's and futures' potential financiers.

3.5 Tests of value concept in practice

3.5.1 Unnerbäck and H₃UNS

In order once more to test the capacity of the concept a final experiment has been carried out as an exercise to evaluate whether the H₃UNS value scale would be considered inclusive by different user groups, when compared to the Unnerbäck value concept model, which in contradiction is based on value exclusion.

The comparative test of the Unnerbäck model (UM) with the H₃UNS concept model (HM) was carried out in three test groups on different occasions. The test groups were asked to employ the models on selected buildings, then to reflect on the usability by comparing the value models and finally individually to answer open-ended and multiple choice questions in writing¹⁸¹. The questionnaire aimed at scrutinizing how a value inclusive concept like H₃UNS is received in diverse groups. The subdivision of data received during the content analysis limited the variation of answers¹⁸² i. e. the variables, which then were made comparable through percentages calculations.

The first two groups of respondents tested the value models on buildings on the sites. The last group, were applying the models in theory on a well known local cultural heritage building. This last group of laymen had no prior experience of value assessment on buildings and they alone were the only group which was initially informed that the exercise was a test. The other two accepted the test as an assignment, as part of the course they were attending.

Value	Term	Definition	Value definitions over time	Unnerbäck
H1	historical	qualitative	cultural value, spiritual, social-, event-personal-, relationship-, contextual-, historical-, documental-, anthropological-, traditional-, familiarity-age-, authenticity-, intangible value	building historical patina, society historical, social historical, person historical environmental identity, patina continuity, tradition
H2	historical	knowledge	scientific value, conceptual, form-, decoration/style, aesthetic, person, decorative-, style, aesthetic-, architectural-, knowledge-, artistic value	Architecture historical technique historical architectonic, artistic,
H3	historical	quantitative	construction-, authenticity (surface)-, original-, quality of craftsmanship-, reversibility, condition-, originality value	building technique historical patina/trace
S	symbol		national greatness, landmark,	symbol

Table 351.1 Unnerbäck is limited to historical evaluation in detail and its form, mixing rational and sentiment value judgment might make it confusing to use for anyone outside the group of historians. Students, on the architecture program, doing evaluation exercises consider the checklist long and that value units are overlapping.

3.5.2 Results; experts, students and laymen

Experts. The first mixed group of 26 respondents¹⁸³ were attending an international post graduate course, the CMHB¹⁸⁴ and they were the most experienced of all respondents while they are professionally active within the field of building conservation in their home countries, thus called the *experts*¹⁸⁵. The test was performed during a practical exercise in evaluation of historical buildings sites from dissimilar time periods; from the 16th to 20th century. The outcome of the analysis revealed that the expert group found Unnerbäck (UM) advantageous, due to its ability to set “judgements” on value with comments like “Examines the physical aspects both on the tangible and intangible” or “Be a first good step in a value process”. The UM disadvantages were “lacks/limitations” with comments like; “Lacks nominal value, is of importance today with financial issues” or “Some overlaps may occur when assessing the evaluation”. The UM model was considered to be preferably appealing¹⁸⁶ to architects, followed by historians.

Advantages with H₃UNS were that it was found to be “direct/clear” followed by its efficiency for “management/planning for future”. The comments were for instance “This system is important, because it shows different values of the buildings and show different problematic” or “is a more concrete form of approach to the building/site practical and pragmatic for a resolution”. Disadvantage was again “lacks/limitations” with remarks such as “We cannot make an evaluation on nominal

value because it depends on the memory that we have of the building, we cannot count which one has more nominal value past or present". H₃UNS model, the expert group considered, would appeal¹⁸⁷ both to architects, historians and craftsmen.

Students. On the second occasion the respondents were architecture students¹⁸⁸ and the test was carried out during an evaluation exercise on residential buildings from the 1960's. The outcome of the group comments to the questions showed that the Unnerbäck model's (UM) advantage was its ability to be a "practical tool"; *"Easy to work out specific values"* and *"One has to look, recapitulate more in detail, more aspects to consider"*. When discussing UM's disadvantages "repetitive" was most commonly used, such as *"Multiple values- many overlaps, repetitive"* or *"A lot of the values are very much the same"*. The students considered that the UM model primarily appealed to historians followed by architects.

The advantages with HUNS were identified by the variables; "direct/clear", "value improving" and "quick/easy". *These were expressed as "Contributes to bring an evaluation and helps to decide what is needed to be done with the building"* or *"Easy to comprehend and understand"*. *The disadvantages were lacks/limitations with "The method does not contribute to further knowledge of the existing historical values"*. *Entrepreneurs, investors/tycoons and architects* would found the H₃UNS model just as appealing, according to the students.

Laymen. The last group of respondents was nine laymen¹⁸⁹ who carried out the test and questions after theoretically applying the two value models by valuing a local city hall from the 18th century. The group was the most heterogeneous of all in the study due to their different professional backgrounds. However, since they have been living in the same medieval village¹⁹⁰ for years their relation to the cultural building studied, did unify them. The laymen considered the prime advantage with Unnerbäck to be its capacity for "judgements" on value articulated as *"The evaluation can be made more precise since there are more categories to choose in-between"*. Both "lacks/limitations" and "complicated/confusing" were the variables emerging when considering the disadvantages expressed as *"No nominal value"* or *"More difficult to gather the different value perspectives"*. The UM model had the same appeal for historians as for architects, was their assurance. The "quick/easy" variable summarized the advantage of H₃UNS with comments like *"Simpler and faster"* or *"More down the earth, not as scholarly"*. The disadvantages were as previously "lacks/limitations" expressed as *"Less precise since due to lack of ranking/grading possibilities"* or *"One needs to give more detailed answers"*. The laymen considered that first of all *Investors/tycoons* would found the HUNS model appealing, followed by entrepreneurs and builders.

3.5.3 Findings and discussions

The study's intention was to examine if different evaluators groups considered that the appreciation for built heritage might be more applicable to professionals, if one added new value units; utility and nominal, to the historical ones, traditionally used. The objective was also to see what effect the different group might attach to the broadened value concept and finally, if it could be discerned that the evaluator's individual ability, affected their value judgements. All three evaluator groups; experts, students and laymen verified the initial intention that a broader evaluation concept like H₃UNS, most likely appeals to a wider range of professionals; *professional preference* (see table 353.1). Limitations in assessment concepts i.e. describing in depth expert knowledge, as here was exemplified by UM on historical values, might be too challenging for a surveyor¹⁹¹ to succeed fully. Checklists, which emphasize specific issues can in fact be developed on all levels for any professional use, but the more specialised they are for a group, the more limited for external use they will become¹⁹².

The comments indicating the effect of widened value models with additions in H₃UNS, showed that while the *utility* and *nominal* had positive impact, since they were frequently commented upon¹⁹³, the *symbol value* might have less significance, since it was never once commented on¹⁹⁴.

The individual ability of the evaluators finally proved to affect the outcome of the evaluations, especially when the groups discussed the advantages of UM. The detailed checklist for values in this case can be said to have revealed the groups' initial positions. The expert group, which was most familiar with the value expressions used, only made remarks on UM's "usability". The learning situation for the student group, made them consider the checklist as a "practical tool" and the "repetitive" remark might reveal a knowledge gap for its distinctions. For the laymen the checklist structure appeared to bring out their poor knowledge in the field, with comments like "complicated".

Laymen's ability, or inability, to recognize and enhance values in built cultural heritage, will decide its future fate since this group represents public opinion, which can influence the politicians, in turn setting up the cultural budgets. This is why value concepts have to be used, which are inclusive if we are to encourage all groups to see the qualities or values in built cultural heritage.

Groups	Value	Experts	Students	Laymen
Advantages	UM	Judgements	Practical tool	Judgements
	HM	clear, managem.	clear, val.i, quick	quick/easy
Disadvantages	UM	Lacks/limitations	Repetitive	Lacks, compli.
	HM	Lacks/limitations	Lacks/limitations	Lacks/limitations
Prof. preferences	UM	Archit./ Histo.	Archit./ Histo.	Archit./ Histo.
	HM	Arch, Hist, Craft	Entr, Inve, Arch	Investors/tycoons

Table 353.1 Results from the three studies.

The outcome of study on the three test groups indicated that:

- Broader or inclusive value models appeal to a wider group hence they may enable a better value growth, necessary for funding.
- Detailed and specified value structures limit the usability and interpretation for outside surveyors; hence they bring less recognition among other professionals.
- The individual ability of the evaluators did affect the outcome of the evaluations.
- Utility and nominal value are relevant issues for built heritage assessments.

Value assessment of the Unnerbäck model was originally developed for a limited group of professionals to identify the heritage values, based on *exclusion*¹⁹⁵. This group of people was to assist the selection of what historic buildings should qualify for a legal protection and it concerned the legal value, LV¹⁹⁶. The H₃UNS concept, but also the Fielden and Riegl models¹⁹⁷, in contradiction, are values concepts set up by *inclusion* with the intention to promote built cultural heritage based on all value factors that any cultural heritage possibly can offer, to market even its concealed qualities.

The inadequacy of a legal protection grounded only on value assessments which demand the expert's knowledge, have proved to have little impact in times of social upheaval, which alas was the case in Eastern Europe after 1945 and for Maglarp as well¹⁹⁸. For this reason, the limiting value perspective may actually diminish the future prospects for our built legacy, since these are misinterpreted by too many parties. Expert based value concepts¹⁹⁹ have to exist in every profession and will continuously be refined, but must not do so at the expense of excluding other value merits²⁰⁰.

The increasing number of heritage sites proves that built cultural legacy is called for in our society of today, more than ever. These global assets are officially recognized as providers of economic growth, but only if regularly maintained. The current financial deficiency, which this expansion conveys, requires consequently that wider value inclusive concepts like the Fielden, Riegl or the H₃UNS could be used as templates highlighting complete, built heritage assets, to ensure the dialogue between groups and to manage a value growth for encouraging an economic behaviour favourable for its protection, such as heritage funding. However, first the entire financiers' individual value preferences, based on the H₃UNS concept, need to be revealed. This requires more detailed knowledge of the groups concerning their origin, methods and capacity, which is what will be investigated in the following three chapters; 4-6.

3.6 Summary

In this chapter the definition of value was initially discussed, both to express quantity and differentiate quality. To define properties of objects by value exclusion or inclusion is the most generally used and value exclusion is decisive for the legal value (LV), though this proved less effective over time. To analyse value definitions within economics was initiated by the urge to control consumption, where the utility theory added the significance of consumer's behaviour and the essence of the social context.

Tate Modern in London, the destruction of palaces in former East Germany, confirms the impact and vigour of use and symbol values which have been commonly applied in practice over time. The reoccurring value fluctuations actually verify that values are incessant, though they are intangible or uncountable, and they can under the right external conditions be resurrected.

Previous analyses with an empirically based value model, HUNS, demonstrated how value scores will always be unique at some times for historic buildings. Consistent value judgements can only be set with hindsight but nevertheless they are vital instruments for revealing potential values for the marketing of legacy. Notions of value motivates funding, which is why inclusive value concepts could be templates used as temporary "standards" to scrutinize the mechanisms of funding, but without aspiring to represent value concept perfections.

The comparison with a chronological outline of value definitions enabled the refining of the initial model into the H₃UNS concept. Four accelerators could then be located, as the value units were distinguished according to their common or diverging features, yet only two were found to be value enhancing; emotional

and financial accelerators. The study of past time value development showed that specified actions direct the external conditions, which stimulate the accelerators' perception capacity to see values.

In the last section of the chapter the H₃UNS concept was further tested in theory and practice. The first comparison revealed that the concept coincided with two of the five models which strengthen the validity. In the second table the recent research on heritage value was illustrated. Here the studies concerned attempts to quantify the cultural value with new measurement tools and though the intangible historic qualitative value (H₁) was among the most essential, in the previous value models, these new forms may again be too exclusive for the general public, though they do compensate for the incalculable value entities. All measurements of value levels are irrelevant in this inquiry since the attempt is to explore the incentives of potential financiers to induce the mechanisms behind funding.

The final experiment intended to evaluate whether the H₃UNS value scale was considered inclusive by user groups when compared to the Unnerbäck model based on value exclusion. The study proved H₃UNS to be inclusive since it appealed to a wider group while utility value and nominal value were accepted; detailed value structures limit the usability for less experienced surveyors and; the range of ability among evaluators affected the evaluations.

Notes chapter 3

1. The value is regarded as intrinsic just as effectual and is created during the completion of the commodity or painting by the designer himself (the labour), but is not available for all groups. Ruskin writes 1884 in “Munera Pulveris” ...”Value” signifies the strength, or “availing” (of use) of anything toward the sustaining of life, and is always twofold; that is to say, primarily Intrinsic, and secondary EFFECTUAL...” “...Intrinsic value is the absolute power...” “...measurable....a cluster of flower of given beauty..” “It does not in the least effect...flowers, that men refuse or despise them...their own power is within them..” “But in order that this value of theirs becomes effectual, a certain state is necessary in the recipient of it, Ruskin (2010, p. 12f).
2. Professionals such as conservators, art historians and archaeologists.
3. First palaces or manors, then the churches and finally the vernacular architecture. This chronology has been of guidance for the selection case studies in Study1- 2, Skarin Pålsson (2001), Appendix 4.
4. John Locke and his cotemporaries were affected by “natural” forces equivalent to those directing other natural outcomes in society, see Throsby (2001, p. 21). “..the classical approach are: the concept of natural prices...regulated via the forces of competition...” “...as determined by objective forces...Petty’s analysis of the labour-embodied natural price and political price...Cantillon’s... intrinsic values and prices necessary for reproduction..”, see Aspromourgos (1996, p. 157).
5. David Ricardo and Adam Smith; the absolute and intrinsic values, see Throsby (2001, p. 21).
6. The “Wealth of Nations” from 1776, *ibid* (2001, p. 21).
7. The assumptions follow the “Preference ordering” which is a row order of how alternative actions are preferred by a consumer to meet specified requirements, *ibid* (2001, p. 21).
8. Consumption refer to; “The origin of desire”, see Throsby (2001, p. 21).
9. See Throsby (2001, p. 23).
10. Expert judgement is referring to the information content, a legacy being intact or authentic, see Ruijgrok 2005 chapter 1.
11. The UN World Commission on Culture and Development, 1995, p.24-5, 206-7, see Throsby p. 73.
12. See Wees chapter 1.
13. The ineffective and energy consuming brick production in the past, initiated its recycling.
14. In Trakai, Lithuania, at first the bricks from the demolished Bernadine monastery were used for constructing the Grand Duke’s Gedeminas Castel and finally all bricks were reused once more when building the Neo-Gothic Lutheran church, Filipivacene (1997, interview).
15. Letters still remains in Danish archives, which describe how the transport of bricks from the demolished monasteries on the island of Fyn, should be organized by boat to the Castel of Kronborg, Skarin Pålsson (2001, p. 194).
16. The Skt. Petri Kirke, the Sait Peters church, was built in the 14th Century. During the reformation in 1537 the church was confiscated by the king and all its properties were donated to the neighbouring Vor Frue church, in exchange for land which was later donated for the Danish University, Munk-Hansen (1990), see Skarin Pålsson (2001, p. 173ff).
17. This was from 1807 to 1808.
18. Werkstatt des Landeskirchlichen Bauhofes, Bodet (1999, interview).
19. Kulturkirche Jakobi, and in Stralsund another medieval church was rebuilt into an Aquarium already in the 1970’s.
20. The Evangelical Lutheran church in Vilnius.

21. Financial support from the German Lutheran churches made a restoration of the church's interior possible for the newly re-established Lutheran parish, Klimaviciéne (1997, interview).
22. Monastery from 13th century used as hospital from 1600 until 1860 and then as brewery, which in the early 20th century was once more rebuilt into the Museum of History in Ystad.
23. The industrial complex is a former power plant which was restored by the architects Herzog & De Meuron in 2000.
24. The bricks from New Maglarp Church were re-used by Sysaw; South Scania Waste Company, at Spillepengen, Malmö.
25. Wees (1976) and Stein (1977).
26. The Parthenon temple in Athens was first built in the 470's BC.
27. The Twin Towers were the very centre of finance in New York and for the U.S. However, many of the companies residing in the buildings had a high percentage of employees of Jewish descent as well. Since the terror attack was supposedly executed by the Al Qaida; an Islamic fundamentalist group, the towers were most likely symbolic on many levels.
28. See chapter 1, one might say that the original structures were "loved to death".
29. A process analysis of building conservation intrinsic factors; object value, team, legislation and finance, Skarin Pålsson 2001, see Appendix 4.
30. I am a practicing architect, with experience of working in the field of building conservation in Germany, Denmark and in Sweden.
31. Value losses occur, due to social upheaval or fires, but the values as such linked to the built legacy remains indefinitely whether or not it is being demolished.
32. The fact that historic buildings still remain, verifies their respect by society, such as Historic, Use and Symbol values. The interviews with professionals, during Study 1 ascertained the Nominal value as well.
33. "De Architectura Libri Decem" by Vitruvius from the first century BC. The transcript was rediscovered in 1414 in the Montecassino Abbey. The book gives a detailed description of the Roman architecture and has high credibility since it is written by a contemporary practicing architect. De Architectura was translated and one of the most significant literary works in the sixteenth and seventeenth centuries, since describing theory of proportion in architecture, the golden measure, Vitruvius 1-2 (2009, Webb), Vitruvius (2008).
34. The basilica designed to be an audience hall for the emperor in Roman times is considered to be the first role models for churches.
35. Statues and ornamented stones such as columns or capitals were most attractive and this recycling can be seen in early renaissance buildings such as the Cathedral of Pisa.
36. Alberti, L. B., wrote the "De re aedificatoria" in 1452 and additionally Palladio. A. published his "I Quattro Libri dell'Architettura", in 1570.
37. To study architecture by reconstructing the Greek or Roman ruins in sketches belonged to the *Grand tour* education, mandatory for all architects until the 20th century, see Swedberg (1982).
38. The royal palaces on the Palatine began 1720, in 1738 Herculaneum was discovered below Portici and Pompeii excavations began as well in the 1750's, see Jonsson (1976, p 16).
39. Publications such as The "Antiques of Athens" by Stuart and Revett (1762) presented the measured drawings of the temples, Ibid (1976, p 16).
40. Johan Joachim Winckelmann (1717-1768) historian, archaeologist and initiator of the Greek revival, Pevsner (1978, p. 286).
41. Winckelmann classified the antique heritage, which he claimed was developed as a result of climate, culture and society. The development of architecture was from Egypt to Greece and finally the Romans made the "copies", Jonsson (1976, p. 16).
42. Wolfgang von Goethe (1749-1832) was author, explorer and scientist. Goethe was among the first to write about building conservation and value of the built heritage in "Von Deutscher Baukunst" (1771) and in the novel "Die Wahlverwandschaft" (1809).

43. Goethe was educated in the conservation of paintings in Venice, see Kåring (1992, p. 241).
44. Cultural heritage belongs to all mankind which is why the responsibility for its safekeeping shall be shared, was Goethe's principle, Ibid. (1992, p. 242).
45. Jokilehto (1986, p. 116).
46. Demolitions could be punished with up to two years imprisonment. It was the same authorities that first authorized the destruction of royal and feudal symbols in France, Jokilehto (1986, p. 116).
47. Ibid (1986, p. 119).
48. Abbé Henri Grégoire, the bishop of Blois Abbé Henri Grégoire, 1750-1831, invented the expression *vandalism* to put a stop to the heritage destructions in France, Ibid (1986, p. 119).
49. See Kåring (1992, p. 146).
50. Instruction sur la manière d'inventorier et de conserver, Jokilehto (1986, Appendix p. 510, 23).
51. Bacher (1995, p. 21).
52. The legislative protection for monuments in 1887 could preserve only some buildings by public funding, Kåring (1992, p.146).
53. Giovanni Battista Piranesi was an Italian architect (1720-78) and contemporary to Winckelmann.
54. Napoleon was in Rome 1807-1814, Jonsson (1976, p. 45).
55. A. W. Pugin (1812-52) favoured the Neo-Gothic style and declared that the medieval architect was a good workman and an honest Christian, see Pevsner (1978, p. 381).
56. Stulpitz Boisserée (1842-1880), Kåring, G. (1992, p. 251).
57. The completion of the cathedral for the Roman-Catholic community was a strong symbol of religious revival, but for the Prussian leading politicians, like Otto von Bismarck, the restoration represented the merger and union of the German states, Kåring, G. (1992, p. 259).
58. The Cathedral of Speyer in 1847, the brutal rebuilding of formerly ruinous Vorderhohenschwangau palace into the place of Neuschwanstein in 1869 by king Ludwig II of Bavaria or like the restoration of the cathedral in Lund by architect Helog Zettervall in the 1880's.
59. See chapter 1 or chapter 8.
60. Eugène Viollet-le-Duc (1814-1879), influential French architect practitioner and promoter of the "style restoration" with drastic restoration works on Notre Dame Cathedral in 1864 and historical rebuilding of the manor of Pierrefonds in 1870 among others.
61. "Restaurer une edifice, ce n'est pas l'entretenir, le reparer ou le refaire, c'est le rétablir dans un état complet qui peut n'avoir jamais existé à un moment donné", quotation from Viollet-le-Duc, see Petzet and Mader (1993, p. 16).
62. Cathedral restorations like Chechester- Ely, Lichfield Cathedral in the 1860's, Kåring (1992, p. 79).
63. John Ruskin (1819-1900) was a British artist and famous author promoting building preservations.
64. "...the greatest glory of a building is not its stones, nor its gold. Its glory is in its Age" quotation from Ruskin (1857/1989, p. 186). "Neither by the public, nor by those who have the care (...) is the true meaning of restoration understood. It means the most total destruction which a building can suffer (...) it is impossible (...) to restore anything that has ever been great or beautiful in architecture", *ibid* (p.194). "Do not let us talk then of restoration (...). You may make a model of a building (..) but the old building is destroyed, "*ibid* (p.196).
65. William Morris (1834-1896) was a British artist, designer and author. Morris was one of the initiators of the Arts- and Crafts Movement in the 1880's.

66. "It is for all these buildings, therefore, of all times and styles, that we plead.." (..) and call upon those who have to deal with them to put Protection in the place of Restoration, to stave of decay by daily care, to..(.. mend a leaky roof ...(..)" resist all tampering with either the fabric or ornament.."Morris. W 1877, Morris (2008, Web).
67. Camillo Boito (1836-1914) was an Italian architect and engineer.
68. The "Primera Carta del Restauro" and its guidelines; 1. The differentiation of style between new and old parts of a building. 2. The differentiation in building materials between the new and the old. 3. Suppression of moldings and decorative elements in new fabric placed in a historical building. 4. Structural parts from historical buildings which are removed during the process of restoration shall be exhibited in a nearby place. 5. Inscription of the date, or a conventional symbol, on all new added fabric in a historical building. 6. Descriptive epigraph of the restoration work done attached to the monument. 7. Registration and description with photographs of the different phases of restoration. This register should remain in the monument or in a nearby public place. This requirement may be substituted by publication of this material. 8. Visual notoriety of the restoration work done, (Boito Webb 2008).
69. This was recommended since, sometimes beauty can overcome age, according to Boito, see Vieira 2008.
70. „Gott bewähre die Denkmäler vor genialen Restauratoren“, quotation from Dehio in 1905, see Petzet and Mader (1993, p. 17).
71. Restoration project by architect Karl Schäffer in 1900, Petzet and Mader (1993, p. 17).
72. „Wir Konservieren ein Denkmal nicht, weil wir es für schön halten, sondern weil es ein Stück unseres nationalen Daseins ist. Denkmäler schützen, heisst nicht Genuss suchen, sondern Pietät üben“, quotation from Dehio 1905, Petzet and Mader (1993, p. 18).
73. See Petzet and Mader (1993, p. 18).
74. Zentral-Kommission, see Bacher (1995, p. 15). Alois Riegle (1858-1905) was an Austrian art historian.
75. Ein Katalog von Eigenschaften, Ibid (1995, p. 23).
76. Kunst- und Erinnerungswert.
77. Alterswert, see Huse (1996, p. 125).
78. "Historisch nennen wir alles, was einmal gewesen ist und heute nicht mehr ist...einmal gewesen nie wieder sein kann...und unverrückbare Glied der Entwicklungskette bildet, quotation from Riegle, see Bacher (1995, p. 55).
79. See Stanley Price, Talley Jr and Melucco Vaccaro (1996, p. 70ff).
80. Bedeutungsspektrum von Denkmal, Bacher (1995, p. 55).
81. Erinnerungswert is here translated as Commemorative value and Gegenwartswert as the Present day values.
82. Alterswert (here translated as Age value), will "reveals itself in(..)the outmost appearance..(..)outmoded(..)claims to appeals to the masses...(..)revealed in(..)lack of completeness..(..) contrast with..(..)modern ...works ..(..)valid of everyone without exception..(..)The modern viewer will receive aesthetic satisfaction from ...the)..unceasing cycle of change in nature", see Stanley Price, Talley Jr and Melucco Vaccaro (1996, p. 72f).
83. "monuments represent a development of human creation in a particular field..(..)not traces of nature's disintegrating forces...but in the monuments original form as a work of man..(..)the Parthenon..(..).... as a ruin can only be regretted by the historian as a development of a Greek temple ...or)..the stone masons craft ", ibid (1996, p. 75).
84. "Were as age value is based on decay.....historical values cease to stop progression of future decay.... deliberate commemorative value....makes a claim for immortality, an eternal present", ibid (1996, p. 77).
85. See ibid (1996, p. 79).
86. Kunstwert is translated as Artistic value and the Neuheitswert as Newness value.
87. See Stanley Price, Talley Jr and Melucco Vaccaro (1996, p. 81).

88. Relativer Kunstwert is translated into relative artistic value.
89. See Stanley Price, Talley Jr and Melucco Vaccaro (1996, p. 80).
90. Max von Dvorák (1874-1921) 1916, art historian, scientist, author and curator of public monuments in Austria. He replaced Reigel, who died unexpectedly in 1905.
91. Dvorák (1916, p. 22).
92. Inhabitants not in favour of heritage protection is due to their; "...(1) Lack of knowledge and passiveness, (2)...arrogance and deceitfulness, (3)...misunderstanding future or present demands and (4)...exaggerated beauty demands..", Dvorák (1916, p. 7).
93. Italy in 1870 and Germany in 1871.
94. ICOMOS predecessor, Jokilehto (1986, p. 416).
95. Ibid (1986, p. 418).
96. "Restoration projects are to be subjected to knowledgeable criticism...().. to prevent mistakes which will cause loss of character and historical values", nr 2 Carta del Restauro, Congress in Athens (2008, Web).
97. Limited damages, major damages and practically destroyed buildings, by Guglielmo De Angelis d'Ossant, the Director General of Antiquities and Fine Arts in Rome, see Jokilehto (1986, p. 425).
98. See Stanley Price, Talley Jr and Melucco Vaccaro (1996, p. 230). Cesare Brandi (1906-1988) Italian art historian, professor Palermo University and conservation expert assigned by UNESCO. His "Teoria del restauro" (1963) Rome, refer to his work, which originally was written in the 1950's.
99. See Vieira (2008, p. 3).
100. "If we continue the analysis on terms of the historical point of view, we are faced with a double problem regarding works of art: the conservation or removal of additions and the conservation and removal of reconstructions().....an addition to a work of art is nothing more than new testimony to human activity...() Thus additions will be worse, the closer it comes to being a reconstruction; while the reconstruction will be all the more acceptable if, the more it differs from the addition and tries to form a new unity in place of the old one" quotation from Brandi, see Stanley Price, Talley Jr and Melucco Vaccaro (1996, p. 235).
101. Jokilehto (1986, p. 430).
102. International meeting of architects and technicians of historical monuments, which was arranged by the French authority, Jokilehto (1986, p. 436). The 61 countries represented, ICOM, ICCROM, The Council of Europe and Unesco.
103. Just two years before of the devastating flooding of Venice in 1966.
104. The "International charter for the conservation and restoration of Monuments and sites", 16 articles, Venice Charter (2008, Webb). ICOMOS got established.
105. "The conservation of monuments is always facilitated by making use of them for some socially useful purpose. Such use is..., see Appendix 2, ARTICLE 5 The Venice Charter (2008,Web).
106. Quotation from ARTICLE 9, The Venice Charter, see ibid (2008, Web).
107. Harald Langberg from Denmark was the only Scandinavian at the ICOMOS meeting in Venice 1964.
108. The International Symposium on the introduction of contemporary architecture into ancient groups of buildings, meeting in Budapest on 27th and 28th June 1972. Hungarian National Committee of ICOMOS and to the Hungarian Government, The International Symposium Budapest (2008, Web).
109. "The authenticity of historical monuments.. ().. must be taken as a basic criterion..., see Appendix 2, see International Symposium Budapest (2008, Web).
110. Resolutions of the International Symposium on the Conservation of Smaller Historic Towns in Rothenburg an der Tauber, 29-30th May 1975, see The Resolutions of the International Symposium Rothenburg (Webb 2008).

111. "Smaller historic towns can be classified into different types which are characterized by problems in common and by specific features which vary... see Appendix 2, Ibid (2008, Web).
112. "To counteract the dangers threatening smaller historic towns...()... ensure their conservation by assigning them a role..., see Appendix 2, ibid (2008, Web).
113. October 1975, European Charter of the Architectural Heritage (2008, Web).
114. "the Council of Europe drafted the Charter which appears below. It is, of course, not sufficient simply to formulate principles; they must also be applied" ... see Appendix 2, Ibid (2008, Web).
115. Congress of the European Architectural Heritage 21-25 October 1975, Declaration of Amsterdam (2008, Web).
116. "Apart from its priceless cultural value...see Appendix 2, ibid (2008,Web).
118. "Planners should recognize..., see Appendix, Ibid (2008, Web).
119. "In particular it can induce new activities to establish themselves..., see Appendix, ibid (2008).
120. "The conservation of the architectural heritage, however, should not merely be a matter for experts..., see Appendix 2, ibid (2008, Web).
121. "The conservation effort to be made must be measured not only against the cultural value of the buildings but also against their use-value" Ibid (2008, Web).
122. "The Revitalization of Small Settlements", organized by the Mexican National Committee of ICOMOS and held in Trinidad, Tlaxcala, from 25 to 28 October 1982, Declaration of Tlaxcala (2008, Web).
123. "They further observe... see Appendix 2, Tlaxcala (2008, Web).
124. ICOMOS National Committee of the German Democratic Republic, participants from 11 countries held a symposium in Dresden from November 15th to 19th, 1982 on the subject of the "Reconstruction of Monuments Destroyed by War", The Declaration of Dresden (2008, Web).
125. ... "In reconstructing monuments destroyed by war"..., see Appendix 2, ibid (2008, Web).
126. ... "The need to continue the traditional use"..., see Appendix 2, ibid (2008, Web).
127. ICCROM; International Centre for the study of the Preservation and Restoration of Cultural Property.
128. Sir Bernard Feilden (1919-2008) restoration architect; *Emotional values*; wonder, identity, continuity, spiritual and symbolic. *Cultural values*; documentary, historic, archaeological, age and scarcity, aesthetic and symbolic, architectural, townscape, landscape and ecological, technological and scientific and *Use values*; functional, economic, social, educational, political and ethnic, see Feilden (1994, p. 6).
129. The Italian National Committee, under the patronage of the Ministry of Cultural Property and of the Environment, Rome 9-10 June 1983, see The Declaration of Rome (2008, Webb).
130. .."Serious consequences due to the fact that architectural restoration" ..., see Appendix 2, ibid (2008, Web).
131. Australia ICOMOS, The Burra Charter (Webb 2008). The Burra charter has a version from 1999. Cultural significance, (2008, Web).
132. "Nordiskt seminar om Byggningshistorisk forskning og restaurering" Copenhagen.
133. Johannes Exner, Danish restoration architect (1926-).
134. War, climate, financial decline, see Exner (1991).
135. ICOMOS New Zealand, see New Zealand's Charter (2008, Web).
136. Protecting the historical, archaeological, architectural, technological, aesthetic, scientific, spiritual, social, traditional characters, Ibid (2008, Web).
137. Authenticity Heritage Convention held at Nara, Japan, from 1-6 November 1994, see Nara Convention (2008, Web).
138. ICOMOS National Committees of the Americas, met in San Antonio, Texas, United States of America, from the 27th to the 30th of March, 1996, see Declaration of San Antonio (2008, Web).

139. Declaration of ICOMOS marking the 50th anniversary of the Universal Declaration of Human Rights, September 1998, see The Stockholm declaration (2008, Web).
140. Kulturminneslagen (1999, p. 20). This law is based on the cultural act for protection of remarkable buildings from 1941 and followed by the law of listed buildings in 1960, which finally became the law of cultural monument in 1988.
141. International cultural tourism charter; Managing Tourism at Places of Heritage Significance, see International cultural tourism charter (2008, Web).
142. See Throsby (2001, p. 28).
143. Mapping, Thick description, Attitudinal analysis, Content Analysis and Expert appraisal, Ibid (2001, p. 28).
144. See Schwanborg (2002).
145. The Church refurbishment subsidy (Kyrkobyggnadsbidrag) from the Church Antiquarian Replacement Fund building, chapter 5.
146. Values such as age, original, economical and social ones, see Schwanborg (2002, p.14).
147. ICOMOS's Charter Principles for the analysis, conservation and structural restoration of architectural heritage 2003, see Victoria Falls (2008, Web).
148. Unnerbäck (2003).
149. The Swedish National Heritage Board; Riksantikvariämbetet.
150. Such as personal-, architecture- and society historical values, see Unnerbäck (2003, p. 24).
151. This includes architectural-, environmental-, traditional-, patina and continuity values, see Ibid (2003, p. 24).
152. Council of Europe, Faro, 27 of October 2005, see Faro (2008, Web).
153. Xi'an declaration on the conservation of setting of heritage structures, sites and areas. China, October 2005, see Xi'an declaration (2008, Web).
154. Declaration of Foz, see Foz (2008, Web).
155. Ibid (2008, Web).
156. Quebec declaration, see Quebec (2008, Web).
157. Digital communication tool are suggested to be used efficiently for low cost inventories, Ibid (2008, Web).
158. Developed and tested in Study 1, see Skarin Pålsson (2001, p. 19).
159. Stuart and Revett drawings of the Greek temples, see note 39.
160. Decorative parts or asymmetries developed over time.
161. See Chapter 1.
162. The Classements, Morris, Boitio, Dehio, Riegel, Dvorák, Brandi, Venice, Budapest, CoE, Tlaxcala, Fielden, Burra, Exner, Nara, San Antonio, Stockholm, Mexico, Unnerbäck, Faro, Xi'an, Foz, Quibec, see table 332.6.
163. Riegel, Athens, Brandi, Venice, Fielden, Burra, Nara, Sweden, Unnerbäck, Xi'an, see table 332.6.
164. Vollet-le-Duc, Scott, Boito, Riegel, Brandi, Tlaxcala, Fielden, Burra, Exner, Nara, San Antonio, Churches, Zimbabwe, Unnerbäck, Faro, Xi'an, Quibec.
165. The fact that details have a positive impact on value, does not guarantee that original parts automatically will be preserved. They represent the most labour intense and expensive features to conserve, when considering its size. For this reason original decorative parts are at times substituted with new components, which to the layman's eye might "look the same". This approach will nevertheless undermine the authenticity of built heritage.
166. The embodied energy, see Stein 1977 chapter 1.
167. The French legislation from the early 19th century.
168. Brandi, Venice, Budapest, The Council of Europe, Rothenburg, Amsterdam, Dresden, New Zealand, Nara, S. Antonio, Mexico, Unnerbäck, Faro, see table 332.6.
169. Leading to Neglect see Svc. Mergeles Marijos basznycia in Vilnius or the demolition, see Maglarp chapter 1.
170. Amsterdam, Tlaxcala, Rome, New Zealand, Mexico and Faro.

171. Restoration or even rebuilding works.
172. The Dresden charter and by Feilden.
173. Expressing overwhelming feelings of hatred or strong affection.
174. Since H_1 seems to be unaffected of time this may either confirm its significance or that this value unit is easier expressed in writing and therefore favoured by authors.
175. See page x. Values are human intellectual interpretations of built constructions, which exist though they become temporarily “concealed” or oblivious.
176. Consciously or subconsciously we all might exploit or stimulate the accelerators of other individuals in order for us to reach specific goals.
177. Actions; Threat, Access, Information, Finance growth (actual/ expected), Ideology and Duty. The accelerators are Emotional-, Financial-, Political- and Obligation. The latter OA can only emphasise the legal value.
178. See p. 96.
179. See Chapter 1, Peacock and Rizzo (2008, p. 157).
180. The reoccurring value fluctuations verify that values are incessant which under the right external conditions can resurrect, in spite of these being intangible (intrinsic) and often uncountable.
181. See Appendix 3.
182. Eight in all; three for *advantages* and five for *disadvantages*, see Appendix 3. The variables refer to the number of answers available.
183. The expert group was represented by 13 men and 13 women.
184. The CMHB is an abbreviation for Conservation & Management of Historic Buildings.
185. The expert group included; architects, historians and technician who were professionally involved within the building conservation filed in Latin America, Asia, Africa and Europe.
186. In the study defined as professional preferences.
187. With some minor variations, see Appendix 3.
188. One male and six females.
189. Five women and four men.
190. The medieval town of Skanör with its church and castle ruin from the 14th century.
191. They would need to possess the same skills such as the value model inventor or be more familiar with its definitions. This would perhaps require that they had identical professions during the same time period.
192. When a carpenter is selecting original wooden constructions for reuse, he will be guided by a value concept, which is adapted to or relate to his profession; just as the one that conservator use when evaluating mural paintings for refinement measures. In both situations a layman from the outside will have trouble identifying the real meaning or sense of their value concepts and even so the more detailed or refined a value concept become.
193. Both in positive, but also negative, terms.
194. “(positive)..That HUNS considers utility value”, “(UM) Lacks nominal value, is of importance today with financial issues” and “We cannot make an evaluation on nominal value because it depend the memory that we have of the building, we cannot count which one that have more nominal value past or present”, see Appendix 3.
195. Art historians and building curators .Value definition of exclusion, see page 88.
196. Legal value, this expression is established in this study.
197. See page x.
198. See page x, re-cycling of monuments in general.
199. The historical values could individually be further defined for a limited set of professionals and for research.
200. The use of an inclusive value concept will entail that many different groups have to contribute to the concept just as all need to be flexible and except more. Heritage authorities in general have a strict non-use policy, thus strong objections against up-dating interior settings in cultural buildings.

4. Acquiring private funding

4.1 Introduction

The financiers of built cultural heritage today are of a most heterogeneous character and this is why systematic analyses are vital. Previous case studies of international conservation projects describing practice¹ indicated that the financiers had influence over the conservations projects that they supported. This might relate to the fact that the incentives for funding built heritage are most likely individualized because their *value preferences* (VP) differ. These tendencies were revealed since they affected decision-making and team structures². Private and public financiers were found to be the two main sources, with unique imprint on the preservation ventures. The definition of private financiers bears upon all non-governmental funding with a national or international work area³. The public funding on the other hand only concerns the national allocation of governmental funding means.

The Maglarp-Allhegona case illustrated that external conditions stimulated human acuity so as to change peoples' value perception and unexpectedly see new potential in one church. This implies that value losses can revitalize since these do not relate to the static historical buildings, which was confirmed by the fact the churches actually had several uniting features⁴. Only built heritage with a stabile value can attain funding which endures. With the assumption given that values are incessantly present in building heritage, which could be re-established by *accelerators*, the H₃UNS concept was designed as a broad, value inclusive criterion template to use as index for scrutinizing this communication process. The mechanism behind heritage funding is presumably induced by changes in the external conditions, so called *actions*, which may stimulate accelerators of some financiers, who will be motivated to act as soon as they distinguish their own *value preferences* in the built legacy. Not all benefactors answer to the same external actions and consequently encourage heritage funding, in which case the financier's individual value preferences need to be revealed.

The private funding group is thus investigated in this chapter consistent with the OMAS format⁵, where the *Origin* (Who?) and *Methods* (What?) will convey essential facts to settle the value preferences (VP). In this way the *Accelerator* (Why?) would become apparent and the funding solidity can be set by revealing

if it is *Sustainable* (How?). A systematisation of facts managed furthermore to render a comparison of the mixed financiers possible and this is further illustrated in the three following chapters.

4.2 Origin

In this outline, the most significant and consistent private financiers of today supporting built cultural heritage have been delineated. The Council of Europe in this case is an exception since it is publicly financed by the member states, but their significance for the development of heritage funding explains their presence in the list. The list does not aspire to be all encompassing, but is intended to provide substantial knowledge of the various private groups in order to detect their significances and future capacity for dealing with the growing funding deficit in today's society. In this paragraph the financier groups are initially chronologically reviewed and in line with their geographical domicile; Europe, the USA and Asia, Africa. The abbreviations of the associations used in texts are not official ones, but here applied only for practical text purposes.

4.2.1 Europe

The National Trust (NT) 1895, Great Britain (T)

A reaction against industrialisation and its effect on British, rural built heritage was the reason why a group of Victorian philanthropists⁶ founded the National Trust (NT) in 1895. British Parliament in 1937 authorized the trust to hold country houses, land and ancient buildings⁷ and NT received several abandoned properties and capital as a result of the transactions of war goods by the National Land Fund⁸. Approved financial legal acts⁹ turned out in favour of the trust and certified their activities. After launching *The National Trust Magazine* in 1968 the commercial side of the organization developed as well, rendering sales of items and the spreading of information possible. This increased the membership rate, which exceeded one million¹⁰. During the centenary in 1995 when NT's website was introduced as well as additional successful campaigns, this more than doubled the amount of members. The membership rates continued to rise when Prince Charles was elected president in 2003 and today the National Trust has over 3,5 million members and possesses both land¹¹, villages and cultural buildings¹². Until 2005 NT was governed by a Council but today a board of trustees is in charge of the daily work, appointed by the council, they are the trustees of the charity National Trust¹³.

The present policy for any new ownership is much restricted, due to NT's already substantial estate holdings. The properties which can be accepted have to be of national importance, threatened, self-supporting or when a trust ownership is the only solution. Business efficiency as well as transparency of all NT's activities are the main objectives which endorse confidence in the National Trust board from their beneficiaries; the British people¹⁴. Income from tourism, day visitors and farming represent NT's financial revenues from the built historical sites¹⁵. Research, commissioned by National Trust on the effect of cultural environments, has been of guidance in management planning. The outcomes verify that beautiful landscape and historical sites are driving forces for job opportunities, as well as for growth of rural economies¹⁶. All properties owned by the NT are either inhabited by the former owners or adapted for a new use, for example as rental cottages or hotels. The estate holdings are expected as far as possible to bring profits and are also marketed through "The Handbook". NT as a charity depends on membership support¹⁷ as the main source of income¹⁸ and on additional subsidies. Through different awareness campaigns NT regularly runs appeals to raise money, but continuously receives grants from the Heritage Lottery Fund (HLF), English Heritage and the European commission.

The Council of Europe 1954 (CoE), Europe (F)

With the aim of solving the post-war problems the future CoE administration was assembled for the first time in 1949. The Human rights declaration was signed by the member states in 1950 and four years later this was followed by the Cultural Convention¹⁹. The convention was established to enhance the significance of cultural heritage as one of the "corner stones of European cultural identity"²⁰. A technical committee appointed in 1969 began to support the Council and create an effective instrument for opposing the threats against the built heritage. This in turn triggered the European Architectural Heritage year 1975. This was an awareness-raising campaign which had a very positive effect upon inducing the protection of built heritage all over Europe. The ambition to develop means for safeguarding the European built heritage, has also contributed advancement towards one of CoE's major goals; that of creating unison between the member states. Another prosperous event was the introduction of "The European Heritage Days" *La Journée Portes Ouvertes*, first organized in 1984, but 20 years later arranged in 49 member states²¹.

CoE has grown considerably since 1990, with new member states from the former Eastern Europe. In 1993²² new strategies for creating innovative financial and legal instruments were discussed to secure the recourses needed for the cultural heritage and historic environments²³. Individual presidencies are able to launch research projects where CoE collaborates with the European Commission.

Their collaboration began as early as 1987 on funding issues of culture and heritage²⁴ and today the Commission is one of the major financiers of built heritage in Europe through their Structural Funds and Framework Programs. The “Ljubljana Process – Funding Heritage Rehabilitation in South-East Europe” was organized recently and it aimed at ensuring public and private funding²⁵. Public endowment from the member states finances all activities in The Council of Europe and the European Commission.

The Landmark Trust 1965 (TLT), Great Britain (T)

Sir John and Lady Smith founded The Landmark Trust (TLT) in 1965 with the purpose of rescuing neglected historical buildings of significance. In accordance with their role model, the National Trust, all cultural properties in TLT’s possession are adapted for use as holiday homes and open to the public for rent. The majority of their holdings are in Great Britain, but some are in Italy and the U.S. as well. The proceeds from the letting can cover the buildings’ regular maintenance costs²⁶. More than 200 buildings have been saved by the TLT and the aim is to raise 10 million pounds to extend their work. As a charity the TLT relies to some extent on voluntary resources such as manpower, other than revenues from the letting activities. The recent tax reliefs set up in the UK have been very favourable for The Landmark Trust²⁷.

World Heritage Fund (WHF) 1972, UNESCO (F)

UNESCO launched an appeal worldwide when the Egyptian government announced their plans to construct the High Dam²⁸ which would submerge the ancient temple Abu Simbel. A rescue attempt to avert destruction of the temple was carried out between 1964-68²⁹ thanks to financial contributions from 50 countries to cover half of the expenses³⁰. This joint action encouraged UNESCO to develop The World Heritage fund by merging the two movements; preservation of nature and preservation of cultural heritage. The fund was established at The General Conference in Paris 1972³¹. The statement in the Convention confirms in article 15 all member states financial commitment in statutes, that “*The resources of the Fund shall consist of: compulsory and voluntary contributions made by States... “funds raised by collections... Committee shall have decided on the implementation”*”. The member states were all to submit an inventory of the domestic cultural and natural heritage for the World Heritage List (WHL) in order to be entitled to funding³². The more recent “List of World Heritage in Danger” represents monuments from the WHL of higher priority where UNESCO needs to allocate an immediate assistance from the WHF since this heritage represents the most endangered properties.

The criteria set up by the WHF for receiving endowments are that the building conservation projects shall fulfil at least four of the five strategic objectives which must be accounted for. These *five C's* involve; credibility, conservation, capacity-building, communication and communities that are accounted for.³³ Similar funds-in-trust have been set up inspired by WHF to support conservation projects world wide³⁴.

In 2002 the World Heritage Committee (WHC) initiated the Partnerships for Conservation, PACT, where the World Heritage Fund in cooperation with other public or private groups, contribute to building protections funding³⁵. The regular and mandatory membership fees, as well as other financial contributions from the participating states, constitute the funds' income.

The Swedish Association for Building Preservation 1975, Sweden
Svenska byggnadsvårdsföreningen (SBF) (A-G)

During the Architectural Heritage Year in 1975 a large number of building conservations were carried out in Sweden³⁶. With inspiration from these united efforts at building protections, the Swedish National Heritage Board³⁷ made a proposal to all their employees. In cooperation with the regional authorities in the counties, they were to set up an NGO; a Non-governmental organisation. This was to be an association of experts' knowledge for the encouragement and exchange of experiences in building conservation, which were gained from practice on building sites during 1975.³⁸ The Swedish Association for Building Preservation developed into an information centre which began on a small scale, by spreading photo-copied leaflets on various building conservation issues. Additional public subsidies made it possible to employ a secretary, but it was, not until a new chairman was elected that the organisation began to grow.

New contacts were established on a large scale with associations³⁹ and companies, which began to buy advertisements, for receiving positive exposure in connection with building protection projects⁴⁰. The former leaflets' information could in this way develop into a periodical, which in turn attracted new members to the organisation. They arrange practical summer camps in building conservation, conferences, spread information on preservation issues via their Web page and their periodical. The SBF is a non-profit making organisation with close ties to the authorities. The National heritage board supports the association by one third but other than that they rely on membership fees and the profits from their own events⁴¹.

The Architectural Heritage Fund 1976 (AHF), Great Britain (F)

Founded in 1976 as a charity, The Architectural Heritage Fund (AHF) promotes conservation of historic buildings all over Great Britain. The association cooperates with other charities such as local Building Preservation Trusts (BPT) which are regularly established for individual conservation projects⁴². Rescue projects can be established as a BPT's revolving fund for a particular group of houses, with programmes of how to acquire, repair and resell buildings. A local BPT can for instance receive advice, information and financial assistance from AHF; either as grants or low interest working capital loans. Urban and rural regeneration projects have high priority for the fund and its positive effects in these areas on the surrounding houses have proved to create new jobs⁴³.

The local authorities can also receive financial support from AHF for buildings at risk when they are working in partnership with other private charities, which then will act as a go-between for the funding. Only listed buildings or houses in historical areas receive financial contributions, especially where the ownership and their present functions will be altered⁴⁴. The administration costs in AHF are all covered by the British government and this is why all private funding that the foundation receives will always be earmarked for actual building measures and recycled by the fund⁴⁵. The AHF receives support from government agencies, private donors, membership fees and additionally makes revenues on their own activities.

The Messerschmitt Foundation 1978, Germany (NPO)
Messerschmitt Stiftung (MS)

The industrial fortune of the inventor and engineer Willy Messerschmitt was set up as a foundation in 1969 to provide support to promising scientists financially. In 1978 The Messerschmitt Foundation (MS) altered its alignment and also began to sponsor cultural heritage in Germany⁴⁶. Financial transactions in the 1980's improved the financial solidity for the foundation and made it possible for MS to contribute on a larger scale to rescue conservation projects⁴⁷. After the Berlin wall had fallen in 1989 the neglected built legacy in the former German Democratic Republic became their main concern.

The financial support of the restoration works executed on the "Neue Wache" in Berlin⁴⁸ and The Belvedere in Potsdam, established MS as a most important sponsor of national building protection. The MS's staff is intensely involved in all work phases of the conservation projects they fund; from planning, managing, supervising to controlling⁴⁹ and encouraging the adaptation of historical buildings to new income-generating functions such as hotels or museums. In the past 20 years the foundation has become more involved, practically as well as finan-

cially, in projects abroad, which once used to belong to German territory. The Messerschmitt foundation is one of Germany's largest private foundations due to a solid capital it receives as the proceeds from its own hotels and restaurants⁵⁰.

German Foundation for Monument Protection 1985, Germany
Deutsche Stiftung Denkmalschutz (DSD) (F)

With the motto "To secure our history for the future"⁵¹ the German Foundation Deutsche Stiftung Denkmalschutz (DSD) was founded in 1985 by 23 of the most influential companies in the country, on the initiative of the federal building conservator in the state of Hessen⁵². Since the British National Trust was their role model initially, the foundation intended to procure individual endangered monuments to secure, repair, restore and finally adapt them for a new use. However, the rapid fall of communism after 1989, and the unification of Germany, totally changed the situation and challenged DSD to take on a far greater task⁵³. In these new federal states an overwhelming part of the cultural heritage was at risk since it had been neglected since 1945. All private properties in the former DDR were all confiscated by the state after the Second World War and this was why the question of establishing ownership was furthermore extremely complicated⁵⁴. The complexity of the situation inspired private individuals to become involved and begin to support the DSD financially. In 1991 the proceeds from the television lottery *Glück Spirale* were also assigned for DSD and building protections. This income, and the so called *BVS* money, which once belonged to the former communist party in East Germany, represents two thirds of the capital in DSD⁵⁵. Donations from companies and private persons contribute with the last third of the earnings.

DSD is a private non-profit foundation, which works based on two major convictions; to preserve endangered cultural heritage and to promote its protection by motivating as well as activating all private individuals. DSD personnel cooperate with local authorities and architects on all projects, by actively participating in all phases; from planning, managing, supervising to controlling⁵⁶. The project "Cultural Heritage in Young Hands"⁵⁷ is one out of many where the foundation activates young private groups for monument protection. The general rule for private funding by law is never to cover more than 50% of the expenses in projects and thus authorities will be equally encouraged to take their financial responsibility⁵⁸. To arrange guided tours to historic sites is another tactic and the growing media exposure regarding projects, has increased direct funding as a bonus. For instance the ZDF broadcast "Bürger, rettet Eure Städte" (Citizens save your towns) and concerts in television "Grundton D"⁵⁹. The heritage protections by DSD have helped create skilled jobs in the regions, increased business for sup-

pliers and contributed to tourism profits; income resources for the future. The foundation so far has preserved 3 000 historical monuments⁶⁰.

The recent financial decline in Germany, with cuts in public spending, has increased the appeals for more private support of conservation projects⁶¹ and “the enormous task of preserving this precious heritage can only be achieved by working together”⁶². DSD depends on private donations from companies, organisations and private persons but has developed alternative forms in order to receive and secure their funding⁶³.

The Foundation for Cultural Heritage in Finland 1984, Finland (F)
Stiftelsen för kulturarvet i Finland (SKF)

The donation of four estates was the starting point for establishing the Foundation for Cultural Heritage in Finland in 1984. The foundation has launched a network of experts to promote professional maintenance and conservation works on their properties. SKF also want to promote their know-how to the public and let their properties be role models for good conservation. Today the foundation does not have sufficient capital to cover the funding required for maintaining their properties, let alone for other cultural heritage at risk⁶⁴.

The Association Culture and Business World 1988, Sweden (A-G) Föreningen Kultur och Näringsliv (FKN)

With inspiration from Arts & Business in London, the Association Culture and Business World was established in 1988 as a part of the Swedish Industrial Society⁶⁵ and the network CEREC; European Committee for Business, Arts and Culture. Since the organisation works with promoting good between industry and cultural institutions, so as to make these constructive for both parties, the main concern for the association is to make all bequests and sponsoring deductible from tax in Sweden. To some extent culture sponsoring was possible in Sweden and some private companies made donations to culture institutions or events. Lately attempts have been made which were rejected due to unfavourable court judgements being passed regarding verdicts for tax exempt on donations⁶⁶. The FKN approaches these issues either by writing reports⁶⁷ or by preparing bills for the financial department in favour of tax exemption.

Since Sweden is one of the few countries not to accept tax reductions for culture sponsorships, the FKN is convinced that policy changes will soon materialize⁶⁸. Meanwhile they prepare the grounds by organizing sponsor-matching events. On these occasions the culture sector can define their needs to the business world and all parties are able to distinguish how such teamwork might be

advantageous⁶⁹. FKN depends on membership fees, private contributions and proceeds from their own events⁷⁰.

Uni Foundation 1990, Norway (F)
Uni stiftelsen

In 1990 the Uni foundation was established after a fusion between two insurance companies⁷¹ thanks to a generous donation to the Uni Research Foundation. Uni grant applications which are for the common good, improve physical environment and projects unable to attain finance elsewhere. During 2008 10.2 % of their donations were delegated to building conservation works of different kinds. Uni is the only foundation in Norway to grant measures to improve fire safety in the existing building legacy⁷². The foundation revises applications for grants but has no promoting activities.

The Castles of Brandenburg 1992, Germany (F)
Brandenburger Schlösser (BS)

In the cultural landscape surrounding Berlin more than 500 significant palaces with extensive park areas, were erected from the 17th to the 19th centuries⁷³. The aftermath of the Second World War meant that private properties in former DDR⁷⁴ were confiscated by the state and not until the merger of Germany in 1990 could the former owners retrieve their old family estates. However, not all families were considered appropriate as palace proprietors, since Russia at the time was to approve these return deals as well. German families that used to be involved in the Nazi movement during WW2 were for instance excluded from the “estate return”⁷⁵. Other families had financial problems and could not afford⁷⁶ to invest what was required in their decayed estates or in some cases all family members might have deceased. A large number of historically important manor houses were for this reason at risk in Brandenburg since a majority had been neglected or misused for a number of years. One way out of this predicament for the state of Brandenburg was to turn to DSD. With inspiration from the National Trust, the state of Brandenburg and the German Foundation for Monument Protection (DSD) set up the “Castles of Brandenburg” 1992 as a company for public good.

The major assignment for The Castles of Brandenburg today is to secure, preserve⁷⁷ and adapt the palace properties by adding new technical solutions called for by the future tenants. BS needs to locate and promote suitable leaseholders for the manors who wish to vitalize the neglected heritage again for a reasonable rent⁷⁸. Conservation works on estates of this size are always time-consuming and labour intensive in order for sites to be conserved using traditional materials and building techniques. For this reason minor sums of money are set up

for renovation works⁷⁹ on a yearly basis since traditional building conservation requires more manual labour. The 14 estates in Castles of Brandenburg's possession have created new jobs and contributed to strengthen prosperity in the estate surroundings. After 1989 the eastern parts of Germany, and former DDR state, had the highest unemployment rates in the country. Today the foundation is run completely independently of the initial investors, – the state of Brandenburg and Deutsche Stiftung Denkmalschutz, since retrieving sufficient means from the lease holding activity of the preserved palaces. The surplus attained will always be reinvested in the continuous conservation projects but also for temporary investment in other palace preservations in the area⁸⁰.

Norwegian Heritage (NH) 1993 (A-G)
Norsk Kulturarv

This advocacy group was founded in 1993 by the Oppland County Council⁸¹. The main purpose of the foundation is to preserve Norwegian cultural heritage by providing guidance, projects of practical enterprises in cooperation with private and public interests and tourism. Norwegian Heritage depends on membership fees, private contributions, Internet sales and proceeds from their own events.

Foundation for the Native-country, 1996 France (F)
Foundation du Patrimoine (FDP)

The fund was established in 1996 according to French law to support conservation works on French built cultural heritage and British National Trust was one of their role models⁸². Just as in the German DSD, initial capital for setting up the foundation was donated by the largest companies in France⁸³. Since the investors; the companies, are the founders, they also have seats in the council. A private owner who applies to the FDP receives the "Fondation du Patrimoine's" label, when approved. The label entitles owners of heritage sites to tax deduction⁸⁴ for all maintenance and restoration works required. Built heritage of cultural significance, which has no legal protection or listing as a historical significance, qualifies for the temporary tax concessions. The buildings must on the other hand be situated in rural areas, visible from the main roads and may not generate any income⁸⁵. The estate can still remain private and closed to public access when preserved⁸⁶. To encourage more private sponsoring "Firm foundations"⁸⁷ have been developed as well to encourage companies or associations to fund. The FDP has successfully engaged companies for sponsorship over time and succeeded in promoting private persons for donation or to become members⁸⁸.

The Realdania 2000, Denmark (NPO)
Realdania (RD)

After the devastating fire in Copenhagen 1795 the Danish state established a lending institute for citizens that had lost their homes in the flames⁸⁹. As years passed the interest capital grew in the real credit company Realdanmark. In 2000 the Danske Bank⁹⁰ purchased and merged with Realdanmark⁹¹ and the foundation of Realdania (RD) was established. In order to return the capital that was originally reaped from the fortunes of Danish people themselves, Realdania designated a charity for the public good. The chairman of the board, and parties from the building sector gathered to discuss the most urgent needs and they settled for investing in improvements of the built environment⁹². Building conservation became one out of three focus areas, since more than 80% of the building industry concerns measures on built legacy. The other two focuses, centre on financial support for the “The future for the building sector” and “Quality in the cities”.

RD’s work policy, other than funding, is to give advice, initiate debates, but also promote scientific research, which is applied individually in every project. The most essential motivation of RD for the selection of conservation projects for approval is that these shall be prosperous, and not only so for the building but also in order to be of importance for an entire community. The project managers are requested to present realistic strategic planning, which can verify how a funding may contribute to general improvements, on many levels⁹³. Realdania receives over 700 applications a year and may select approximately 20 of these for their support⁹⁴. The staff in RD⁹⁵ works in close contact with project managers and they make regularly supervisions, but have minor influence over the selection of consultants⁹⁶. However, all conservation or adaption works must be executed according to the internationally agreed conservation standard⁹⁷. The conservation projects, which are funded with a specified sum of money, are either the “flag-ships” or listed buildings⁹⁸. Different ways of matching funding are common and the financial burden usually is shared between owner, authorities, foundations or others.

In RD’s campaigns, other funding methods are applied as well on heritage sites and then Realdania cover all the expenses. Campaigns which are developed as pilot projects have also proved to be successful for RD to use and they themselves become the active initiators or driver⁹⁹. These projects are first prepared by RD themselves and in a second phase the owners and other groups are involved, when the finance planning is presented. Since the RD support is to be for public good, for this reason some of RD’s ventures may affect the privacy of the proprietor negatively. To participate in “Historical gardens” for example, the owners must agree that the park area become publicly accessible, in order to receive funding

for the conservation works. The owner commits himself as well to maintenance on an annual basis¹⁰⁰.

Apart from their heritage funding, Realdania launch information campaigns in Danish schools on architecture and building heritage, but also for the public in general, as well as the building sector, by sponsoring well established institutions¹⁰¹. RD's subsidiary company Realia takes care of instant investments in culture at risk by purchasing, redeveloping and reselling assets at a profit. Norre Vossborg, a medieval castle on Jylland, is one example where Realia have made investments to secure the estate, adapt the existing barns and add new constructions for a conference facility. RD has also supported the *Byggningskultur Danmark* (BD) which operates as an umbrella organisation uniting all Danish associations involved in building conservation¹⁰². The *Byggningskultur* has all the practical competence required when it comes to building conservation matters and give advice to owners of culture heritage sites. All investments made by Realdania are allocated to different kinds of activities to ensure a minimal risk and a good return to cover all RD's expenses¹⁰³. In 2000 RD set up 50 000 Euro for grants and in 2006 the sum rose to 278 million Euro¹⁰⁴.

Danish trade and industry foundations 1965-1981 (DTIF), Denmark (F)

Velux Foundation 1981, Sonning Foundation 1965, Augustinus foundation and Rockwool foundation 1981 exemplify some of the many private financiers that allocate funding to building conservation ventures in Denmark¹⁰⁵. The foundations are often manufacturing firms from the building industry, which can explain their concern for built legacy. As a general rule it can be said that these foundations are all quite discrete with their support and they seldom advertise their presence themselves with signs at building sites¹⁰⁶. The application approvals in the same way are discussed behind locked doors in the board rooms. An advisory expert in conservation matters is then invited to assist the management in their decisions. Facts and figures about their cultural endowments are in the same way not publicly available. A publishing house has developed efficient search tools over the years for applicants to find the most appropriate funds out of the 7500 which are available¹⁰⁷. Danish trade and industry foundations have the capacity to donate 3 billion DKR annually¹⁰⁸.

German assistant organizations (GAO), Germany (A-G) Fördervereine

These local advocacy groups and voluntary fund-raising phenomena¹⁰⁹ in Germany represent spontaneous neighbourhood backing associations. The *Fördervereine* are accessible to all inhabitants who are committed to protection of

the local built heritage and cultural goods, such as art or music. Their collections of private pecuniary contributions, arrangements of concerts or meetings and voluntary manpower inputs, seem to have just as good an impact on other local groups and thus are fully comparable to any larger campaigns set up by heritage authorities. The local commitment in Fördervereine accelerated in new eastern states after 1990 but they used to exist during DDR times as well¹¹⁰.

4.2.2 The United States and Canada

Samuel H. Kress Foundation (SKF), The USA (F)

In 1929, during the depression the industrialist Samuel H. Kress established a foundation. Its first mission was to set up and prepare a touring exhibition¹¹¹ to introduce Italian art to inhabitants of 24 American cities. Kress was a dedicated and self-appointed cultural ambassador who wanted to share the European artistic legacy with the American people during these difficult times. This philanthropy today allocates financial support in three major areas¹¹² where the protection of significant art and architecture in Europe is still granted by the Kress Foundation, but often in collaboration with other foundations such as the World Monuments Fund.

World Monuments Fund (WMF) 1965, USA (F)

A passion for engineering and monuments made the retired American army colonel, James A. Gray establish the International Fund for Monuments in 1965¹¹³. The devastating flooding of Venice in 1966 spurred UNESCO to involve international governments and the private sector in the conservation works needed¹¹⁴. The WMF got involved as well in this extensive rescue project, but their initial experiences from international conservation missions in Ethiopia and Easter Island, had given them the pre-knowledge of how to leverage funding and rely on local resources. For this reason WMF began to inspire interested groups in the U.S. to establish “Venice committees”, set up as local offices all over the U.S. Each of them “adopted” a monument in Venice at risk and every branch had to raise the funding by themselves for “their own” building. The results proved to be a success. The Venice-aid project, arranged by WMF, also got unexpected support, from the Italian government, since all UNESCO contributions were exempted from value added tax¹¹⁵.

Ever since the Venice experience, WMF has been committed to protect the world’s most endangered places and still holds the unmatched record¹¹⁶. The work strategy of WMF is signified by the great variety of programs and each of them has their own budget and conservation mission to pursue, such as collabo-

rations in *The American express partners in preservation program* from 2006. The *International challenge funding program* has for example spent 15 million dollars on 145 projects in 54 countries during 2007¹¹⁷. In *The Sustainable Tourism Initiatives* the objective is to integrate historic preservation, sustainable tourism management and visitors' education¹¹⁸. There is a demand for the program differentiations, since they can manage a tailor-made funding and the support is urgent; "*human activity is the leading cause of irreparable harm to...the world's treasured places*"¹¹⁹

The reason why WMF can work actively in so many different parts of the world¹²⁰ is on behalf of their work policy. The Foundation starts up projects together with the "grassroots organizations" that consist of all parties involved, from the governmental agencies to the local community groups in each country. Together they form a global network and the local groups work under the consultation and directions of WMF staff in New York and in Europe¹²¹. The offices employ technical field project staff and consultants who guide the implementation of WMF projects in cooperation with local partners. This cooperation model has led to donations from local charities and authorities¹²². Due to the fact that legislative advocacy diverges between countries, the WMF begin with identifying specific strategies and incentives which prevail in each country. As a next step they propose a cost effective investment strategy to apply. The fund does not always insist on match-making agreements as pecuniary assets but instead as manpower, as recently practiced on a Buddhist temple in northern India¹²³. The foundations' activities around the globe give them a tremendous awareness of problems and threats against the world built heritage¹²⁴. In recent years WMF has been evolved in collaboration with the Iraqi government¹²⁵ to secure monuments at risk, since the recent war.

The last decade's expansion of the foundation's area of operations will most likely increase further, as more projects continuously lack the means for planning, management and conservation¹²⁶. The fund experienced a significant growth and during a 10 year period 1997-2007 the program expenditures increased by 450%. All of this is needed due to the increasing costs¹²⁷. WMF is most anxious that the fund expenditures primarily are allocated to the practical conservation projects which today represent more than 85%¹²⁸. The fund's ability to set up partnership with local groups world wide, creates regional understanding, which WHF say is their key to success¹²⁹. The foundation is an independent non-profit organization with no formal ties to UNESCO. American Express has always supported WMF financially over the years but the fiscal donations from private individuals represent the most generous group¹³⁰. Cooperation with Samuel H. Kress Foundation made WMF also get involved in European art and architecture at risk.

New York Landmarks Conservancy 1973 (NLC) (NPO)

By the end of the 19th century the Municipal Art Society was founded inspired by the “City Beautiful” movement¹³¹. The Society formed a committee¹³² a decade later that could work more hands on with building conservation. It was the environmental movement in the 1970’s¹³³ and the centenary of the US Constitution, which helped to attract attention towards building conservation¹³⁴. Inspired by the Historic Charleston Foundation¹³⁵ a committee was in this way established in 1973; New York Landmarks Conservancy and they started to purchase and restore historical houses of significance. The senator Daniel Patrick Moynahan’s¹³⁶ strong commitment in conservation matters was essential at the time just as were Brandon Guildon’s articles in the *The New Yorker*¹³⁷. The NLC is the only preservation organisation in New York City which provides financial grants and practical support for maintaining, restoring, and the re-using of historic buildings. NLC assists owners in all phases¹³⁸ and if desired they suggest architects, other consultants and craftsmen presented on NCL’s webpage¹³⁹.

To begin with only one member of staff was employed at NCL, though supported by an active board. The projects involved only single projects, such as the preservation and re-use of the U.S. Customs house. The conservation and redevelopment of the Federal Archive building in Greenwich Village became much more profitable for the NLC and for this reason the revenues could be reinvested. The NCL for this reason could set up one of the largest revolving funds for building protection in the U.S.; *The Conservancy’s Historic Property Fund*¹⁴⁰. Since the commencement in 1973, the staff has increased fifteen-fold and the building assignments are now spread out all around New York City. Programs focusing on target buildings have been developed by NLC over the years and have their own grants. The “*Sacred Sites Program*”¹⁴¹ from 1986 focuses on deteriorated sacred properties and helps congregations with grants and technical advice¹⁴². Other programs are “*The City Venture Fund*” for non-profit community developer 1986, The “*Endangered Building Fund*” and “*Upper Manhattan Preservation Fund*”, to mention a few.

The opportunity to receive loans or funding for any private owner of built cultural heritage is indisputable. However, NCL experiences of working with easements have shown that this form is among the most effective for saving buildings at risk¹⁴³. The idea behind easement originates from amendments made to the Landmark law in the 1980’s and the trading of air above or around a building in New York City, which was introduced. Obstacles to overcome for NLC were initially that the preparation of easement could not be invoiced, but when a fund¹⁴⁴ has been set up for this purpose this stumbling block was eliminated. NLC today has 43 easements in the City and the Segram building was among the first ones in

Manhattan. Every fifth year the NLC commissions an architect to check in order to see how the owners fulfil the maintenance demands, which are specified in the easement.

Prize awards are also excellent ways to secure quality and give positive feedback to all parties in the field of building conservation, according to NLC, just as advocacy is, since they attract publicity¹⁴⁵. Information material produced by NLC and the periodical "*Common Bond*" assists all subscribers with technical support. For more complicated works that demands expert skills, as well as for detailed cost estimations or constructional engineering, NLC commissions firms from private practice. For instance to estimate costs of the conservation works needed on Ellis Island¹⁴⁶ or when the last remaining part of the World Trade Centre's the *Survivors Staircase* was to be moved from Ground Zero, in the spring of 2008¹⁴⁷. NLC also regularly designates a number of individual buildings to the Landmark Preservation Commission for listing, which NLC reckons is the first and most important step for any rescue campaign¹⁴⁸. This is possible thanks to the regular contacts NCL has with 53 historical conservation groups which are the advocates for buildings at risk in their communities¹⁴⁹. The organization of workshops on relevant preservation topics abroad has made NLC uphold international contacts with colleagues from Cuba and Russia. In spite of the fact that the mayor of New York may have other priorities than the historic legacy, today's discussion on global warming and energy saving, strengthens NLC's position since "*Preservation is green*"¹⁵⁰.

The Heritage Canada Foundation (HCF) 1973, Canada (F)

The Heritage Canada Foundation was established in 1973 as a national, membership-based and non-profit organization dedicated to protecting the built cultural heritage. This also includes promotion of building conservations to raise awareness of Canada's historic places, cultural landscapes including their significance to local communities. Building conservations in practice can only receive technical expert advice from HCF and no endowments; nevertheless HCF does forward contacts to other grant giving foundations¹⁵¹.

J. Paul Getty Trust (PGT), 1982 USA (F)

The operating foundation of the PGT was first established in 1953, when their museum of antiquities was funded in Malibu, California USA¹⁵². A donation in 1982¹⁵³ made it later possible for PGT to extend the businesses and set up new programs¹⁵⁴. The Getty Conservation Institute (GCI) for culture heritage matters was founded in 1985. Its staff gives advice on practical conservation issues covering everything from visual arts to architecture and sites. Thanks to GCI's

advanced scientific research, education and training it has become an important partner and collaborates with other professionals in the field. One of the recent projects is the cooperation with cultural heritage authorities in China. Here the GCI have assisted the local authority experts in developing and implementing national guidelines for cultural heritage conservation¹⁵⁵.

The World Monuments Watch (WMW), 1995 USA (F)

Since today's national listing around the world seldom attracts enough international attention to cover the need for technical assistance and funding, World Monuments Fund in 1995 launched the World Monuments Watch (WMW). Listing strengthened advocacy and has been WMF's most successful instrument for the world's most endangered sites¹⁵⁶ ever since its commencement. American Express has here been a noteworthy financier. Unlike the World Heritage list, the listing done by WMW is not permanent; instead the whole idea is that the list shall constantly be renewed. In keeping with the rate at which heritage rescue projects are completed they will be removed from the inventory. Watch sites are here nominated by all nations in contradiction to the order applied by the World Heritage site listing, which can only be nominated by the UNESCO member countries¹⁵⁷.

The WMW has helped to develop precise solutions for projects on common themes and these are issued every two years. The WMW acts as an effective tool when called for immediate action in urgent needs¹⁵⁸. Since the launch of the Watch program, spending on world heritage sites has increased by 500%¹⁵⁹ and the WMW grants have inspired other contributors to match their support by 250%¹⁶⁰. The built legacy should be preserved and used productively in our times – is the mission statement of WMW. Global climate change affecting the permafrost¹⁶¹ and an increased number of hurricanes along the Gulf coast, such as Katarina, which hit New Orleans in 2005, makes the Watch more important than ever.

4.2.3 The Middle East

Aga Kahn Trust for Culture (AKTC), Switzerland (F)

The Aga Khan Trust for Culture was founded in 1988¹⁶² as a private philanthropic foundation and is connected to the Aga Khan Development Network. The AKTC's mission is to improve the welfare of people in Asia and Africa; the developing world. In order to promote conservation and re-use of buildings as public spaces in historic cities in the Muslim world, AKTC has established *The Aga Kahn Historic City program*. The intention of the program was to encour-

age social-, cultural- and economical development in deprived city districts of historical significance. The Al-Azahr Park that began in 1984 used to be a former rubble dump, which thanks to the support was redesigned into a city park¹⁶³. The adjacent 12th Century city wall, which used to be completely buried under rubble and the residential district of Darb al-Ahmar with a mosque and historic houses, could in the same way also be refurbished (see p. 345). The social aspects of the project helped to provide training programs, employment, credits to small new established companies, a woman's association and health centre. In most funding ventures AKTC cooperates with other financiers such as the Getty Grant program, WMF and the Ford Foundation.

Flemish Funds-in-Trust (FFIT), Belgium (F)

The Flemish Funds-in-Trust was established in 2000 when Flemish authorities supported the development of World Heritage management capacity in the Arab States. FFIT's objective for the trust is to spread information about cultural heritage to the general public and to improve the management by updating archive material. The foundation has formulated how to implement the mission of the trust. In cooperation with a local partner the FFIT first designs a Webb page on the World Heritage in Arabic. Next, to advocate heritage promotion locally, further pilot studies are launched, work shops and scientific networks established¹⁶⁴.

4.2.4 Defining the parties of private heritage funding

To distinguish significances and structures among the vast group of private financiers, first of all, their uniting and diverging qualities were established. This primarily concerned their abilities to assign a financial support, either in cash or as services and their own solidity. This subdivided the 25 associations into four definable funding groups; the Trusts, the Foundations, the NPOs and the Advocacy groups, in the section above indicated by abbreviations; T, F, N and A-G. Foundations proved to be the most common form of financier though this is less frequent in the Scandinavian countries. The groups are specified later in this chapter.

Private financiers of heritage funding			
Trusts	Foundations	NPOs	Advocacy groups
National Trust	Council of Europe	Messerschmitt Stiftung	Sv. byggnadsvårdsföreningen
Landmark Trust	World Heritage Fund	Realdania	För. Kultur och Näringsliv
	Arch. Heritage Fund	N Y Landmarks Con.	Norsk Kulturarv
	Deut. Stift. Denkmalschutz		Förderverine
	Stift. kulturarvet i Finland		
	Uni stiftelsen		
	Brandenburger Schlösser		
	Foundation du Patrimoine		
	Danish t& i foundations		
	Samuel H. Kress Found.		
	World Monument Fund		
	Heritage Canada Found.		
	J. Paul Getty Trust		
	World Monument Watch		
	Aga Kahn Trust f. Culture		
	Flemish Funds-in-Trust		

Table 424.1 Overview of the private financiers of heritage funding and structured according to the four categories outlined.

Private financiers of heritage funding				
Financiers	Trusts	Foundations	NPOs	Advocacy groups
Nations				
Finland			1	1
Norway				2
Sweden				2
Denmark		1		1
Germany		2		1
The UK	2	1		
The USA		4		1
Add. nations		5		
Total	2	14	3	6

Table 424.2 Illustration of the four financiers groups in relation to nationality.

4.2.5 The contextual development; Trusts, Foundations, NPOs and Advocacy groups

To disclose the mechanism behind heritage funding of the four private funding groups here defined, involves scrutinizing the core incentives which once initiated the associations in their funding ventures. Dates of establishment could in this case be applied to explain significance of motivation, when compared to relevant occurrences, or *actions*, of importance in the past, for built environment during the 20th century. As already discussed, external actions may stimulate accelerators to encourage the perception of values in built heritage. The individual relation and level of attachment to the chronological outline of the past therefore, might

elucidate characteristics of the financier as a group; how they operate, by revealing their *value preferences*, regulating their finance commitment.

The expansion of the private associations dedicated to heritage funding gives the impression this trend has been a spontaneous growth. To understand the actual structure, the contextual course of events in history therefore needs to be revealed. However, using a graphical time line illustration with the foundation date, according to historical development, means a structure could be identified. The outline of the time span actually revealed five distinct time eras, which indicate the development of private heritage financiers as follows; *Period of threats* (1885-1945), *Post-war period* (1946-1953), *the void period* (1954-1964), *the period of turmoil* (1965-1989) and *the merge period* (1990-2008), (see table 425.1).

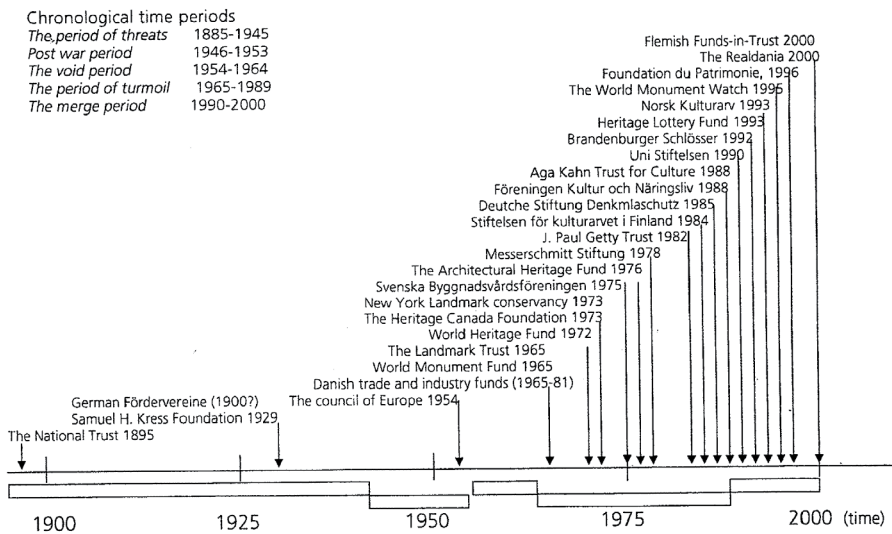

Table 425.1 The contextual development of the private global funding, revealed five distinct time eras.

The first; *Period of threats*, refers to the social upheaval in the 19th century, which was influenced by industrialisation and the subsequent devastating wars. During this time the built cultural heritage that had just become national symbols, was severely damaged or even totally destroyed during warfare. The old social structure and living conditions were transformed. The National Trust set up in 1895 can be seen as an icon of a movement which went on to develop in different ways due to places, from establishing open air museums, to collecting extinct dialects¹⁶⁵ or as building protection in situ as practiced by The National Trust. It started as early as the inter-war period but grew. The second development phase; *Post-war period*, turned the physical rebuilding of the ruinous legacy into a moti-

vation for avoiding future warfare and thereby unifying neighbouring countries under supervision of The Council of Europe 1954. Parallel to this, from the great depression in the U.S. arose the Kreiss foundation. The subsequent third decade of inactivity; *The void period*, can be interpreted as the age of pragmatism where the available capital was primarily rationally spent on reconstructing industry. Astonishing however, was the fact that countries like Sweden, though unaffected by war damages, initiated a building demolishing policy which ended up totally replacing Sweden's historical city centres with new constructions¹⁶⁶.

The privately initiated heritage funding reached other heights after 1965 during the fourth phase; *Period of turmoil*, where natural disasters¹⁶⁷ caused an immediate threat bringing a strong commitment to life and global concern with the World Monuments Fund. Technological improvements¹⁶⁸ that endangered historical legacy, engaged UNESCO members to finance the Abu Simbel project and the World Heritage Fund was set up in the 1970's. These two associations today still uphold a leading position as global heritage financiers, as consistent with their own funding strategies¹⁶⁹. The period ends with the fall of the Berlin wall in 1989. This suddenly gave access to the intact but relentlessly neglected built legacy of the East, which was endangered due to ownership complexity and shortage of building materials.

A majority of heterogeneous funding associations came about during the fourth phase but not only for nations influenced by the Architectural Heritage Year and National Trust. By the time for the heritage year 1975, which can be said to have brought European consensus on the significance of building protection, this movement had already sprung up in the U.S. Here lobby groups for sustaining built heritage such as the NPOs¹⁷⁰ had sprung out of a merger of the building conservation groups and the expanding environmental movement in the 1970's. The Historic Charleston Foundation, active since the 1940's¹⁷¹ had in turn been their obvious role model. Their dedication quickly gained acceptance in society as well as in politics, thanks to their producing results using market oriented incentives, thereby encouraging private funding and promoting reinvestment models within the framework of non-profit¹⁷². The absence of strong centralized cultural heritage authorities as in Europe, dating from the turn of the century in 1900, and the U.S. encourage a bottom up model which still remains, even when initiating legal protective measures to sustain historic buildings¹⁷³.

The final and fifth phase; *Merge period*, is a period of adjustment as regards the new social orders in Europe and represents the timeframe chosen for this thesis. The heritage ventures financed, in Study 1, expose newborn and sentimentally motivated awareness among nations to subsidise their former built legacy, this time on foreign soil¹⁷⁴. During this period new funding sources such as Realdania and the Palaces of Brandenburg were developed, where the former especially mir-

rors the successful NPO financier, which since the 1970's was established in the U.S. by New York Landmarks Conservancy. The former East European nations; Poland, Lithuania, Latvia and Estonia represent the most recent development of non-governmental funding forms and they have been initiated by the countries' recent shift to market economy¹⁷⁵.

The correlation between the time eras and the establishment of the private financiers, disclosed first of all the fact that foundations and advocacy groups were intimately linked. Over time, trends and events i.e. *actions*, stimulated these groups to take a stand as the significance for a built heritage in focus grew from their perspectives. This was the reason why a great number of associations were set up in favour of the monument protections since initiated either by actions of *threat* (Venice in 1966, Abu Simbel 1968), *information* (Architectural Heritage Year 1975) or *access* (the liberation East Europe 1990). The trusts might have been affected by actions at a particular time by exposing built legacy for risk, but as trust funds are continuously set up, such as The Landmark Trust, 70 later than the National Trust, the date seems primarily to be influenced by when the historic properties were entrusted. In the long run the NPOs first and foremost seems to be organized parallel to how the tax concession policy advanced, and less influenced by the course of events in past times.

4.2.6 Finance sources; Trust, Foundations, NPOs and Advocacy group

In all countries the legal structures are intimately linked to the financial systems applied. This is why both are vital to discern in order to explain national significances, since they are equally much affected by the progression of history, culture and religion¹⁷⁶. The generally most accepted legal structures are the common law countries, the civil law-, the post-socialism and the individual Nordic countries. Great Britain with its imperialist past and the U.S. represent the largest group of nations under the legislation of common law. Germany signifies the civil law structures, which to some extent refer also to the Nordic countries¹⁷⁷ though they are often characterized as a separate group. The former East European nations; Poland and Lithuania¹⁷⁸ finally signify the post-socialistic legal structure. The four groups of private financiers discerned are here individually discussed, with references to their geographical domicile and value preference for the built cultural heritage based on the H₃UNS concept.

4.2.6.1 The trust

Equity¹⁷⁹ is a set of rules within common law, dealing with legal questions regarding estates and have helped to establish the legal rights system called a trust. This

early tax exempt model was developed in common-law countries like the UK for the sole purpose of sparing the heir temporarily from paying inheritance tax and fees before he comes into possession of the property. It thus became necessary to appoint a trustee, a relative or friend, who temporarily could overtake responsibility for the estate until the former owner died. The estate was then handed over to the lawful owner of the house, the beneficiary¹⁸⁰. A trust represents a relationship initiated by the settler i.e. the donor, when a property is legally confided by the donor in trustees¹⁸¹. The trustees are obliged to keep and maintain the properties to the benefit of others be it the recipients or the beneficiaries. The purpose of establishing a trust must be a property or an object with a high economic value. The beneficiaries' interests are proprietary and can be traded; bought or sold, but cease to exist when mistreated by the trustees in ways unfavourable to the beneficiaries¹⁸². A trust must fulfil three certainties¹⁸³ in order to be valid, regarding; the trust's intention, the identification of property and the object for establishment that hence is charitable or non-charitable¹⁸⁴. Monuments and sites are commonly used in charitable trusts as bequests and they enjoy fiscal privileges as well as income exemptions from tax¹⁸⁵

Finally when judging the value preference (VP) according to the H₃UNS¹⁸⁶ concept in trusts for built cultural heritage, all assessments seem relevant. The historical values; qualitative, knowledge and quantitative (H₁, H₂, H₃), are always stipulated for enrolling the properties, the use (U) essential to provide the surplus required with the possessions and the condition of the property (N) likewise if it is to fulfil the trust's claim. The donations of abandoned properties after the Second World War thus turned properties into trusts which became symbols of the social changes in British society (S). A trust value preference, VP, hence represents all value units in the H₃UNS concept.

4.2.6.2 The foundation

The civil law countries were united by Roman law which characterizes the European tradition of foundations originating from the Roman Catholic Church with alms as the charitable donation¹⁸⁷. The Nordic countries and the north European legal structures belong to the Roman-German group of justice¹⁸⁸ but their more pragmatic legal character relate to the fact that they practiced early on the landscape laws in the 14th Century¹⁸⁹. The reformation in the 16th century then cut the well-known bonds between foundations, church and the Roman law. The trading sector hence began to set up their own independent charities and this tradition was later continued by companies in the post-industrial societies¹⁹⁰.

Foundations have strict sets of rules to follow drawn up by the government and they are obliged to distribute certain sums for charity annually, to fulfil their

intentions. Depending on national policy in the country, funds might enjoy all tax privileges of the non-public sector¹⁹¹ and have the ability to stipulate very precise objectives or aims stated in their constitution. A few foundations have almost achieved the same sovereign position like for instance the Getty foundation, with its great solidity, based on large donations by the founders. Nevertheless, such an organisation may still struggle to administrate earnings and growth.

The historical values of the H₃UNS-concept are most vital for the foundations when evaluating built cultural heritage. A drastic turn of events in history has often proved to trigger the setting up of foundations. For this reason they are signified by the sentiment motivated H₁; historic quality- and H₂; historic knowledge values. As foundations frequently are closely connected to individual donators, or companies, the communicative historic quantity value H₃ also has to be added, as it often is the decisive value factor among laymen. Value preferences, VP of foundations in other words will be H₁, H₂ and H₃.

4.2.6.3 The NPO

The non-profit organisations (NPO) are not a legally defined association form. The heritage sponsor definition has been developed for this dissertation to describe these solid financiers. The NPOs have the ability to combine all measures that trusts, foundations and the advocacy groups take separately, to protect built heritage. This makes them exceptional among the group of private sponsors. The explanation of NPO's huge capacity is that they are entirely independent of external public or private financial support, since they are self-sufficient. For this reason the NPOs here exemplified, draw up their own ideological agenda with the main purpose of making profitable investments in building heritage to secure its future continuation. These financiers are required to have a board competence among the employed professional staff in order to manage the charitable organisation efficiently¹⁹² and this is not without importance to a distinctive and uniting goal. Thanks to legal tax-exempt incentives, U.S. examples such as NPO, the New York Landmark Conservancy (NCL), have developed a number of models to promote funding and improved commitment to sustaining the built cultural heritage. The connection to locally engaged historical groups ensures their bottom up approach. The skilful use of broadcasting media goes some way to explaining their successful development and impact on the built cultural heritage agenda today.

The Danish equivalent, Realdania, is a foundation by constitution but due to the solid working capital, their business-like and pragmatic approach to built heritage funding, qualifies them in this study as an NPO. The self-supportive Messerschmitt Foundation (MS) has also been included in the NPO group, but only based on theoretical information on the association¹⁹³.

The highly professional attitude to funding measures for built heritage turns the NPO's focus away from qualitative and sentimental historical values. Their quest is to achieve financially viable outcomes of well prepared financial investments in historic buildings. This is why they favour only the rational and quantifiable historic value of H_3 . Additionally, those thus also secure a profit return; utility (U) and the equivalent finance growth of nominal value (N). The NPO thus has H_3UN as value preferences, VP.

4.2.6.4 The advocacy group

Organizations, associations and more or less well structured societies of people joined by the emotionally motivated consensus to preserve built heritage here signify the advocacy group. Since representing the most diverse group of actors their ability and methods to promote legacy, from an endangered historic city block to individual buildings, varies between countries and point in time. Even though their pecuniary support is modest, their strong dedication and enthusiasm compensate for this inability through the extensive asset of the committed manpower they can manage to mobilize. By transmitting information through all possible channels they have the capacity to inspire others to be committed and trigger response, such as demonstrations, publication of articles or public events. The modest form of advocacy groups is a product of the local grassroots, those living in the vicinity of an historical environment at risk. The more advanced of such are the professional associations that regularly cooperate with foundations (see NLC). Depending on tax-exempt policies the advocacy groups become more or less active as is the case for the NPOs. Independent groups receiving public subsidies, which means they may lose some of their initial driving forces that reflect free emotional reactions¹⁹⁴.

These reactions involving built cultural heritage are significant for the value judgements among advocacy groups and for this reason their value preferences are limited to the sentimental value units of historic qualitative; H_1 and historic knowledge value; H_2 .

OMAS; Private financiers of heritage funding					
Financier	Origin	VP	Method	Accelerator	Sustainability
Trust	14 th C; property	$H_{1,3}UN$			
Foundation	20 th C; events	H_1, H_2, H_3			
NPO	1973's; tax policy	H_3UN			
Advocacy group	Non stop; events	H_1, H_2			

Table 4264.1 Private financier groups according to the OMAS format, here (O). The parties' value preferences could as well be set based on date of establishment and group descentent.

4.3 Methods

The funding forms identified in this thesis, and obtainable from the private financiers, are of four types; direct funding, transmitted funding, replacement funding and credit funding. As indicated by their different expressions, only the most common *direct funding* (DF) offers contributions as ready money. The *transmitted funding* (TF) implies that the financier donate the promotion service to a building conservation project with the intention only of inspiring others to fund; to market the heritage for the general public. The *replacement funding* (RF) denotes that the heritage support is only available in an alternative form to the cash payment. The form corresponds to all structures of voluntary work as hands on manpower work in theory or practice. The *credit funding* (CF) available only in the U.S.¹⁹⁵, and represented by the NPO, has proved most successful.

4.3.1 Trust, the role model

All land and properties today under the responsibility of the National Trust (NT) were initially confided by the British government, or private families, to the trustee, as trust agreements. The NT is hence responsible to keep, maintain and care for all properties for infinity, in the best possible way for their beneficiary; the British people. This is why all estates and historical sites have to be accessible to the general public at all times and it is possible thanks to the large number of local voluntary workers. The regular maintenance costs for up-keep are to some extent automatically covered since the properties are used either as museums, holiday homes or inhabited by the former owner. Over the years NT has developed a number of activities for all age groups to advocate the built heritage and its protection. To ensure that the properties can continue to generate income in the future as well, it is vital for NT that the younger generations continue to uphold appreciation of historic buildings. This public exposure and accessibility for all groups implies that the fragile environments and estates are always continuously exposed to a degree of wear and tear which they were never originally intended for. For this reason availability takes its toll¹⁹⁶ which makes the financial support even more essential¹⁹⁷.

The trustees presented here allocate no funding for other building conservations then those of their own holdings. All proceedings gained from the cultural properties, campaigns and branded products¹⁹⁸ are always reinvested in the trust goods. In spite of the fact that The National Trust has its limitations when it comes to external funding of the built legacy, the trust primarily has been a tre-

mendous source of inspiration and a role model for a great many other heritage funding organizations.

4.3.2 Foundation, direct funding

The foundation is the traditional grant donor and practices a *direct funding* form, but it is also the most diverse one owing to its capacity to have its own set of goals for the activities, which have to be specified in the constitution of the charity¹⁹⁹. Though all foundations distribute finance they still represent a wide range of associations, from the most active participating partner, who gets involved in all planning levels in practice, to the most passive observer. In a foundation for instance, properties can be assigned²⁰⁰, campaigns for fund-raising initiated, training programs organized, various forms of joint venture in funding established or advocacy campaigns initiated for heritage protection. A foundation can either develop out of one single capital investment from a family or from several donations like the Deutsche Stiftung Denkmalschutz, but depending on the statutes; act more or less independently from their financiers. When the single investment to a foundation is closely linked to a famous individual or celebrity, such as Bill Gates, these financiers have in this study been referred to as donors²⁰¹.

For foundations such as World Heritage Fund the members play the key role as investors through their membership fees, but also as a reminder that built heritage belongs to all mankind. Global foundations which promote international dialogue on heritage issues, which rely on the pool resources of membership fees from the wealthier nations, may lose their initial intention to promote a dialogue, as it is usually the wealthier nations which end up as the main contributors for heritage protection in the third world countries²⁰². The establishment of foundations has had a random development since it is purely the initial emotional reactions to changing circumstances which primarily sparked their conception. They are moreover a result of emotional reactions inspiring to actions²⁰³. Foundations like the World Monuments Fund and their “Wilson Challenge” plays an additional role, other than as financier when challenging public bodies to “match-making”, which requires an active participation also on the part of the beneficiary counterpart²⁰⁴.

4.3.3 NPO; direct funding and credit funding

Equivalent to foundations, the NPOs provide endowments for building conservation ventures and most frequently apply variations of *direct funding*. The New York Landmarks Conservancy (NCL) endows furthermore different forms

of *credit funding*, which have proved to be most efficient at creating capital. In addition to funding, they themselves possess adequate resources of knowledge and capital, thus they are capable of adapting, promoting, re-using and purchasing as well as re-selling built cultural heritage. The NPOs exemplified in the study may have national characteristics and unique company structures²⁰⁵, but still they have much in common. Uniting them is their ability to change responsibility focus and either act as donors, proprietors, project administrators or program initiators. Uniform to the NPOs presented here is also their ambition to constantly develop new schemes thus securing that protection of built heritage will be advantageous and profitable. However, this is not to ensure their own holdings, but to remain a reliable benefactor of a *direct funding*. Among the private financiers this form involves allotments directed to single heritage sites or as program funding for protecting group characteristics. Moreover, the revolving funds and the entrepreneur programs are here also considered as a direct funding. Nevertheless, the use of broadcasting is more practiced by NLC for their advocacy campaigns when awarding brilliant achievements in the conservation sector or simply for ensuring the close collaboration with local historical groups²⁰⁶.

Not all NPOs have the capacity or tradition and for this reason some examples are here briefly summarized. The Realdania's (RD) direct funding in this case either chooses their "flagships" or makes selections listed among the funding applications. Additionally their own finance programs are funded, such as; *The Future estates, Farming houses, The City Environment*²⁰⁷. In New York Landmarks Conservancy (NLC) the direct funding is available for private proprietors and assigned primarily through programs such as "*The City Venture fund*" for non-profit community developer, The "*Endangered Building Fund*" and "*Upper Manhattan Preservation fund*". The Messerschmitt Stiftung, on the other hand, seems only to favour a funding of single built heritage sites of significance, such as the palace of Meseberg²⁰⁸.

Characteristic for a *revolving fund* is that a capital investment can be re-used more than once to buy, restore and sell historical buildings. This direct funding is practiced by all NPOs presented here. The profits procured will then be able to finance more ambitious projects the next time²⁰⁹. The Historic Charleston Foundation was the first to develop the form in the Nathaniel Russel House²¹⁰. This new finance form was later suggested in The Declaration of Amsterdam 1975²¹¹.

In order to recognize the legal situation of an important building, a non-profit preservation organisation can also get involved in property transactions, for example involving a tycoon in an *entrepreneur program*. The objective is to rescue a building at risk by reselling the historic building²¹² with an improved form of protection, which is used both by RD and NCL. To preserve the Federal Archive

Building, for instance, NLC launched an entrepreneur program which could provide a considerable profit. The NLC this time prepared a preservation plan for a future mixed use and sold the leasehold to a developer with an easement. The requirement, defined in the easement, was to restore the building to a standard set up in the plan. Proceeds from this sale²¹³ later were reinvested as a permanent endowment in a fund to support facade renovations and religious properties²¹⁴.

The early tax-exempt reform in the U.S., from the 1970's, here referred to as indirect funding, most likely has encouraged widening the supply of *credit funding* forms, such as easements or bonds. The credit funding is not applied by the European NPOs presented in this study. A historic conservation *easement* is a legal agreement allowing the owner tax exemption equivalent to the value of the property and is a partial purchase of an historic building. This binding contract is between an owner of a property and a qualified party such as a non-profit easement-holding party like the NLC. They initiate this investment deal by purchasing a piece of a threatened property and reselling it to the owners or other investors, with an easement which enables tax exemption and a commitment to its maintenance for eternity. In 1976 the easement became a legitimate agreement and is today considered to be one of the most important preservation tools for heritage at risk²¹⁵. The purpose of an easement is to protect a cultural property since the deal requires the easement owner to follow certain conditions, which then again guarantee regular building maintenance. Holders of easements are namely eager to ensure the continuous value increase since this ensures his tax concession, which only a regular maintenance will guarantee. An easement can be established by a cautious building owner who donates²¹⁶ or sells a part of the rights on a property, to an easement-holding association with the legal authority to enforce the terms of the tailored easement²¹⁷.

Façade easements are most commonly used and the San Antonio projects in the 1980's were among the first successful examples²¹⁸. Easements tend to increase the value of properties and when this positive reaction becomes generally recognized, they will additionally have encouraging impact on their surroundings²¹⁹.

4.3.4 Advocacy group; transmitted and replacement funding

Some of the most important advocacy groups in this study are the Förderverein in Germany, Historical conservation groups as exemplified in New York and Building Preservation Trusts in (BPT) the UK. In connection with most building protection ventures in Germany, a local Förderverein is established as a channel to collect private contributions of either finance or manpower services, and becomes the locally involved mouthpiece. Historical conservation groups in New

York also regularly propose listing of monuments to the NLC. In this way they have initiated many of the preservation projects realised during the last decades in Manhattan²²⁰. These groups ensure also a bottom up approach. Protection incentives in this way are developed locally and this ensures a more sustainable approach since the built legacy will at all times be monitored and reactions can influence political decisions. The British BPT, in contrast to the two previously mentioned self-grown movements, is an organized advocacy group under guidance of The Architectural Heritage Fund²²¹.

The advocacy group is primarily a promoter of building protections, which through teamwork and alliances can gain tremendous influence, in spite of the fact that they lack financial support. These groups can only allocate a *transmitted* or the *replacement* funding. The first entails promoting or inspiring others financiers to sponsorship and the latter refers to all sorts of manpower as volunteer work. For example during conservation on the Statue of Liberty and Ellis Island, in New York, both forms were used in public and private campaign when financial means was to be raised for their conservation²²². The private groups *The Statue of Liberty* and *Ellis Island Foundation* (SLEIF)²²³ on behalf of the government helped to raised 400 million dollars for the project, for instance due to the *Naming Wall*²²⁴. In the 19th century all immigrants to the US had to pass the Ellis Island as it was used as a quarantine holding centre. The fact that many Americans had a historically important relation to the Island was the reason for its success and this was highlighted in the fund raising promotion²²⁵.

To implement a project of this size the public department of heritage authority will always participate. Here they were needed to guarantee that the incentives are in the public interest and as a result the National Park Service, New York branch, was responsible for publishing a project standard for the renovation works, in order for these to qualify for tax exemptions. Additionally they convened citizen's panels continuously to review the cases presented for their approval²²⁶.

OMAS; Private financiers of heritage funding					
Financier	Origin	VP	Method	Accelerator	Sustainability
Trust	14 th C; property	H _{1,3} UN	Role model		
Foundation	20 th C; events	H ₁ , H ₂ , H ₃	DF		
NPO	1973's; tax policy	H ₃ UN	DF, CF		
Advocacy group	Non stop; events	H ₁ , H ₂	RF, TF		

Table 434.1 The four private financier groups according to the OMAS format, here (OM). The Trust primarily has been a significant role model for heritage funding.

4.4 Accelerators

As assumed, motivation for any economical behaviour; such as heritage funding from private groups is the fact that built cultural heritage has capacity to signify values for society; an objective for concern. The condition of this human perception, or acuity, is the *accelerators*, which encourage benefactors to recognize value potentials. Financers' unique origin and variety of funding forms applied, from transmitted to direct funding, indicate that their appreciation of value in built heritage will also be individualized, thus diverse. This is why a mapping or financier's value preferences (VP) could be used to regulate the supply of funding. With the H₃UNS concept as a value template the individual value preferences of private financiers are proposed to be set accordingly; Trust value preference approved on all values, the foundations concerned H_{1,3}, the NPOs link to H₃UN and the advocacy groups see H_{1,2}.

Persistent value fluctuation will affect built heritage and temporary "conceal" some values. This may limit its respect and reduce its funding at times. However, unless a value loss were possible to improve from outside by planned or unplanned *actions*, no value increase would occur²²⁷. The neglect in its trace, would finally lead to the loss of built environments. Yet, the fact that ancient buildings still exist consequently confirms the influence, which external actions must have on the intellectual accelerators to stimulate funding²²⁸.

4.4.1 Trust; obligation accelerator and no funding

Motivation of the trust's persistent dedication to the entrusted heritage sites is the legal binding agreement, between trust and beneficiaries. The National Trust is by law assigned to maintain the monuments in a good condition, so that they always can remain accessible for the beneficiary; the British people. With the use as holiday homes, museums or semi-private residences these obligations have been fulfilled over the years. The regular visits however expose the legacy to a degree of wear and tear which was never intended in the first place, but is a requirement owing to the trust agreement. For the NT to retrieve sufficient funding for the regular up-keep and live up to the public accessibility requests, a variety of activities are also regularly arranged at the sites to encourage visitors to spend their money. A majority of NT's members and sightseers are from senior citizen age groups, programs for this reason have been tailor-made for school children in order to reach the younger generations. Over time and due to age and the early use of the internet introduction, NT has established an influential position vital for marketing as one of the most important role models in the built cultural herit-

age sector. What ensures value stability of the entrusted legacy is not any varying external conditions stimulating accelerators. On the contrary, this is solidly set and preconditioned in the legal commitment which guides the trust agreement in the NT's day to day work. This duty bound commitment is so in this study, referred to as the *obligation accelerator*.

The value preferences of the trusts entail all parameters based on H₃UNS concept and are artificially stabilized by the trust treaty. An increase of the obligation accelerator will for this reason only imply that additional rules will be added to the normative trust agreement. Equivalent to national heritage site protections, here referred to as legal value (LV), the obligation accelerator only emphasizes obedience or duty to the contract. To enhance funding, so that even trusts could start granting other heritage sites, outside their own jurisdiction, the legal agreements instead need adjustments for making trusts more attractive for new financiers. This could be for example a clause, in the trust agreement, saying that income-generating businesses, such as shopping malls, would be permitted to get established in the vicinity of famous trust sites, if paying a "Trust-Fee". This most likely would strengthen the economic value of land, though hardly be favourable for the entrusted cultural heritage site.

In other words the obligation accelerator cannot augment funding since the value of the entrusted properties is stable and artificially regulated in the legal agreement of the trust, but can be said to correspond to the H₃UNS concept. The stimulation actions of duty will only increase or strengthen the trust treaty.

Template:

Acquiring funding from (financier) via accelerators

$$A + VP = V_A$$

A = Accelerator of value, initiate (initiate no) funding by actions (name)

VP = Value preference of financier; rational or sentimental based on the H₃UNS concept

V_A = Value activating to funding

The mechanism of funding (graphical presentation)

Action ----- Accelerator ----- (VP = V_A)

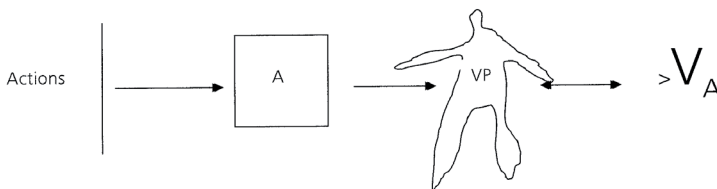

Acquiring funding from the Trust via obligation accelerators ($A+ VP=V_A$)

$OA+ H_3UNS= >Trust\ agreement$

$A= OA$, obligation accelerator of value, initiate no funding by actions of duty
 $VP=$ Value preference of trusts is set in the trust treaty; the complete H_3UNS concept

$V_A =$ Value activating no funding but a role model and strengthen the Trust agreement

The mechanism of funding

Action -----Accelerator -----($VP= V_A$)

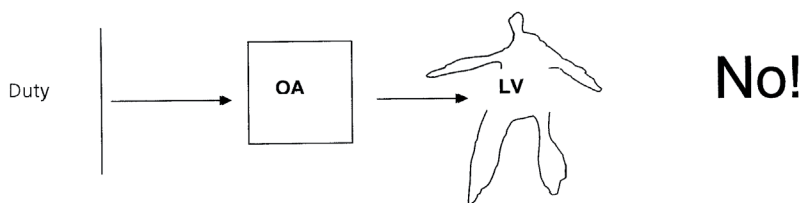

Figure 441.1. The mechanism of funding of trusts can not establish an acquisition enhancement of new finance, since actions of duty only strengthen the Trust treaty.

4.4.2 Foundations; emotional and financial accelerators

The foundations are restricted by national legislations, for instance concerning taxation issues, but their unique constitutions are still directing the objectives that every foundation pursues. This explains the great variety of commitment existing among them, as their establishment above all is a result of emotional reactions, which inspired groups to unite and start up a collection of funds. Two of the most influential parties of heritage funding, the World Monuments Fund (WMF) and the World Heritage Fund (WHF), were set up to prevent loss or decay of heritage at risk, on account of evoked threats²²⁹. The lack of financial independency for their heritage funding, will always place a foundation in a dependency to external backing. The fact that American Express has been a loyal financier of the WMF could be seen as a logical consequence of the growth in cultural tourism²³⁰, which has been gained due to attention brought to the global built heritage as a result of the listing. The membership fees of the nations are in the same way essential for WHF since they intended initially to unite the countries in a common concern about, and against any adversary of, endangered built legacy. The world heritage list in the same way qualifies nations to vital promotion bringing financial input for the local tourism.

All historic value parameters, H_{1-3} , are thus recognized by the foundations for heritage funding to be approved. Based on the foundations unique value preferences, the *emotional* and *financial accelerators* will likewise manage to induce recognition for built cultural heritage. Since the *historic quality value* (H_1) and *historic knowledge value* (H_2), of sentimental kind, are directed by *emotional accelerators*, all funding activities will augment among foundations, when built legacy is exposed to the external *actions*, identified as *threat*, *information of access*. The charities established in consequence of turmoil in society bring emotional reactions to life. War or natural catastrophes stressed the *threat* of losing the heritage and fundraising was initiated. During the 20th centuries nations affected by the two world wars destruction, began to assemble at international conferences by ICOMOS for instance, where experiences and *information* were exchanged. The expanding cooperation world wide has opened and eliminated the separating borders which provided *access* to former secluded areas, mentally and physically. By encouraging relevant actions of the emotional accelerators, enthusiasm for and commitment to built heritage will commence. Sudden demolishing plans in the same way will always have the capacity to become the torch initiating the emotional accelerators to see values, generating behaviour favourable for heritage protection. In this way any neglected historic buildings can theoretically transform into precious assets, even though they might previously have been invisible to local inhabitants.

The most tangible historic quality value, H_3 , on surface characteristics of built heritage is on the other hand induced by financial accelerators and the funding stimulated by actions of finance growth; actual or expected. The value significance among laymen and its media attention can most likely explain the reason why foundations were set up for heritage protection by industrialists or companies in the 20th century. When the emotional (EA) and financial accelerators (FA) are augmented, thus values will increase recognition of built heritage and initiate support from foundations (V_A).

Acquiring funding from the Foundation via Emotional and Financial accelerators ($A+ VP=V_A$)

$$EA/FA+ H_{1-3} = V_A$$

A= EA, emotional accelerators of value initiate funding by actions of information and access

FA, financial accelerators of value initiate funding by actions of actual/expected finance growth

VP= Value preference of foundation; rational and sentimental H_{1-2-3}

V_A = Value activating to funding; direct funding

The mechanism of funding
 Action -----Accelerator -----($VP = V_A$)

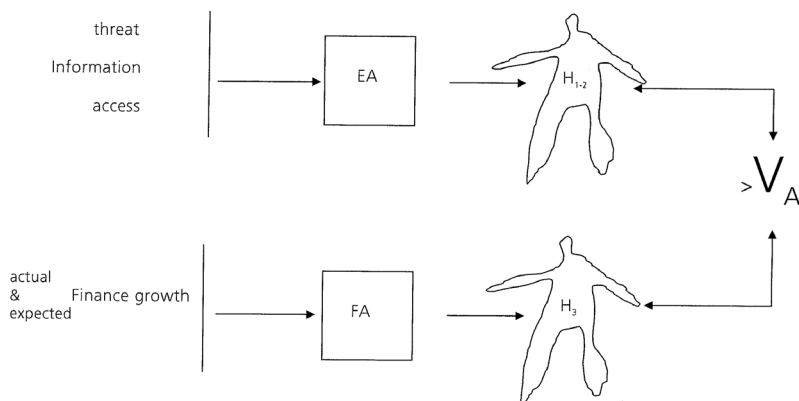

Figure 442.1 The mechanism of heritage funding of foundations, for the acquisition enhancement of new finance, requires actions of information, access and actual & expected finance growth.

The accelerators inducing the foundations to perceive values in built heritage have been identified as emotional and financial, to increase funding. This implies that a social climate exists nationally, which can favour *actions* relaying information about and access to built environment for the financiers, to stabilize the historic quantity- and knowledge value $H_{1,2}$. However, establishing the economic conditions which strengthen the historic quantity value H_3 , require stimulating actions to an actual or expected finance growth by media and tax concessions.

4.4.3 NPOs; financial accelerators

The driving forces for the NPOs to fund the built cultural heritage could have been a reflection of the indicators which guide all other financiers described, due to their vast expertise of acting as donors, proprietors or project administrators. However, their well established cooperation with public or private interest groups assists them in devising new approaches for sustaining built heritage, either as initiator of programs or advocator of built legacy. The NPO's purely rational value preferences of, H_3UN , will encourage them to recognize and perceive building heritage when induced by the *financial accelerators*. The first; historic quantity value, H_3 , represents the key definition of historic buildings among laymen and is essential for all media attention. The others are characterized by the use value (U) generating proceeds and the nominal value (N) which is the financial investment conveying actual or expected finance growth as interest.

The actions, of actual or expected finance growth to promote for the NPOs, are for instance media, tax concessions and adaptations. The historical quantity values (H_3) concern the surface characteristics of historic buildings which prove to have a vast medial impact successful for motivating funding²³¹. Also fund raising campaigns with celebrities marketing the H_3 have proved much effective, as in the Ellis Island project described, but also via brochures highlighting the built legacy, commonly practiced for instance by the British institutions, such as English Heritage.

The utility value (U) can additionally be stimulated by actions moderating the legal protections limitation of use and allowing building adaptations. Moreover, political decisions that are encouraging the nominal value, N, include all tax-exempts and other relief giving investment increase as revenues. Their broad competence in their working teams of mixed professional groups²³², strengthened their abilities to see potential fiscal assets in the built heritage. Their efficient and profitable enterprise model for heritage protection is motivating NPOs to support historic buildings providing they generate finance growth, and thus induce the financial accelerators.

Acquiring funding from the NPOs via Financial accelerators ($A+ VP=V_A$)
 $FA+ H_3UN =V_A$

A= FA, Financial accelerators of value initiate funding by actions actual/expected finance growth

VP= Value preference of NPOs; rational H_3 , U, N

V_A = Value activating funding; direct and credit funding

The mechanism of funding

Action -----Accelerator -----($VP= V_A$)

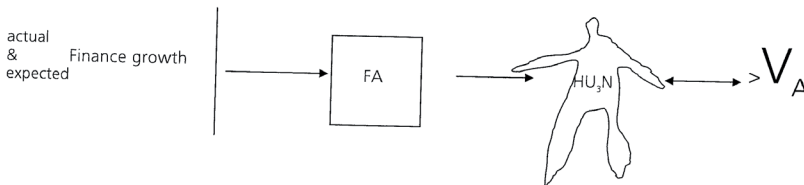

Figure 443.1 The mechanism of heritage funding of NPOs, for the acquisition enhancement of new finance, requires actions of actual & expected finance growth.

Accelerators that induce the NPOs to perceive values in built heritage have been identified as the financial ones and it is these which increase investments. This implies that an economic climate exists nationally, revealing that promotion of potential finance growth in finance markets, for instance through media, tax concessions and building adaptations, stabilizes the historic quantity value H_3 , the utility value U and the Nominal value N .

4.4.4 Advocacy group; emotional accelerators

The basic advocacy groups can be the locally devoted inhabitants or grassroots movements who are driven by anger, passion or dismay into protecting a built environment in the neighbourhood. The more established groups have developed a number of ways of increasing the awareness for others in society, regarding the opportunities inherent when saving built heritage and likely risks with losses otherwise. The depth of their commitment; man-hours invested in events, gatherings and media communication, depends on what each course of action requires, not the site as such. Much of their work is explicitly voluntary and rests on high ideals.

The value preferences of advocacy groups are consequently the historical qualitative and knowledge values, H_{1-2} , which are recognized in built heritage only when induced by the *emotional accelerators*. This sentiment which is the foundation for values, will raise and stabilize, when stimulated by *actions of information* or by *access* to the built legacy, though the strongest incentive, is by ad hoc heritage *threats*. Facts, stories or photos or value inventories available over the internet will augment these groups commitment, just as will the re-establishments of utilization of the inaccessible built environments.

Acquiring funding from the Advocacy group via Emotional accelerators (A+
VP= V_A)

$$EA + H_{1-2} = V_A$$

A= EA, emotional accelerators of value initiate funding by actions of information and access

VP= Value preference of advocacy group sentimental H_{1-2}

V_A = Value activating funding; transmitted-, replacement funding

The mechanism of funding
 Action -----Accelerator -----(VP= V_A)

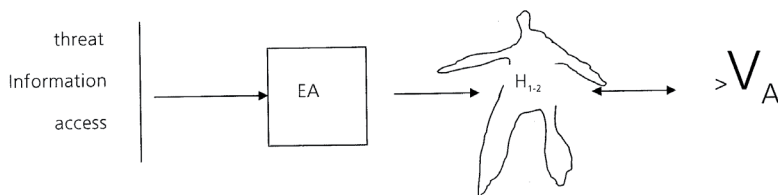

Figure 444.1. The mechanism of heritage funding of the advocacy group, for the acquisition enhance-ment of new finance, requires actions of information and access.

OMAS; Private financiers of heritage funding					
Financier	Origin	VP	Method	Accelerator	Sustainability
Trust	14 th C; property	$H_{1,3}$ UN	Role model	Obligation (OA)	
Foundation	20 th C; events	H_1, H_2, H_3	DF	Emotional, Financial	
NPO	1973's; tax policy	H_1 UN	DF, CF	Financial (FA)	
Advocacy group	Non stop; events	H_1, H_2	RF, TF	Emotional (EA)	

Table 444.2 The four private financier groups according to the OMAS format (OMA). Only emotional and financial accelerators enable financiers to perceive values in built heritage, i.e. heritage funding. Trusts therefore become excluded since obligation accelerator will only affect the trust treaty.

Accelerators that could induce the advocacy groups to perceive values in built heritage have been identified as the emotional, to increase funding. This entails, nevertheless, that a social climate exists nationally, which can favour actions of information about and access to build environment for the advocacy groups, to stabilize the historic quality H_1 - and knowledge value H_2 .

4.5 Sustainability

Funding for building protections, in contradiction to most processes cannot be carried out once and for all, as the weathering of building materials makes building maintenance perpetual. This is why the only enduring solution is to make sure that today's heritage financiers will continue their support and to develop incentives for new groups to begin as well. All financiers have to consider the allocation of endowments, so that the temporary fiscal losses can be resumed, to establish a sustainable heritage funding. One way to determine the economic capacity of a financier could be to reveal the degree of self-sufficiency or reliance they sequentially may have to external funding, as presented here.

4.5.1 Trust, reliance on external finance

Even though built cultural heritage used to be the main concern, when the National Trust first was founded, their recently procured land possessions could still turn into an unsolvable future financial distress, due to the mounting erosion of coastlines²³³. As an attempt to limit the expenses owing to a growing property holding, restraining measures have been taken, just as campaigns are regularly arranged to increase proceeds by reaching new members²³⁴. The level of reliance on external finance and membership fees, as for NT might not be identical for all trusts. This is first of all related to the number of properties or land which has been entrusted and what capacity this has to generate income. However, the trust's profound dependency on the local voluntary workers seems to be collective. For this reason future issue of concern for this group ought to be how to attract younger generations to shoulder these burdens onward²³⁵. This is necessary if we are to fill the looming gap that volunteer groups will soon be leaving behind, since at present the majority of volunteers for these organisations are normally over middle-age or senior citizens.

*“One thing is however perfectly clear for the Trust; without the voluntary workers in the local communities NT’s estates could not be opened to public. We have 40 000 members that do voluntary works locally and their unpaid work is irreplaceable. Others help raise money and all they get is a free entrance to our estates, not even a free cup of coffee”*²³⁶.

The financial insufficiency of the National Trusts is evident already today and this is why strong precautions need to direct all their new-acquisitions onward, if we are to resolve the problems. The entrusted properties have to be the focus and to strengthen the commitment which is free of charge; the trusts have to prove that positive output from the properties first of all will above all be a profitable return locally.

4.5.2 Foundation, varying objectives and less self-sufficient

A majority of the active foundations granting historic buildings were established in the 20th century and depend heavily on external finance for their day to day work. Individual donations from private individuals or companies, subsidies from public bodies and membership fees are constantly required. Even established national foundations like the Deutsche Stiftung Denkmalschutz (DSD) need the persistent external support when struck by decline due to political changes, in spite of their previously excellent conservation records²³⁷. New rules in the European Union, and an increased influence of federal authorities, have

lately left DSD with less allotment of the proceeds from formerly reliable sources as lotteries²³⁸.

Though the demand for support in the built heritage sector is increasing, it seems that even the most established international funding associations are struggling for capital, due to their wide spectra of objectives²³⁹. These may increase administrative costs and finally its efficiency when it comes to the actual heritage funding. The unison that once signified the establishment of for instance the World Heritage Fund (WHF) owing to the successful rescue mission in Egypt of Abu Simbel in 1972, gave the supporting countries a feeling of team-mate solidarity. The growing indifference spreading among some member states today, when neglecting to pay their dues regularly, is costly from many aspects²⁴⁰. The challenge for the foundation is to re-establish the confidence of the team-spirit which once was, especially since the conservation ventures concerned only the heritage on one continent and bridge the growing geographical gap, as the building conservation's mission is now global. However, the demands on all member states imply that all building protections have to follow the stipulated European WHF model, in order to be entitled to funding. This means that part of the financial support is always earmarked to be issued for capacity building; to build through training, no matter the condition of the heritage sites²⁴¹. This might be interpreted as, and serve to kindle, a biased effect by beneficiary nation for a successful collaboration, where the financially stronger nations will always be more influential by dictating what is imperative²⁴². According to the recent evaluations made by the association²⁴³ the *capacity building* through training has been considered as a critical activity for international assistance due to insufficiency of professionally trained site managers. The priority of the international built heritage funding list first of all follows the least developed countries, the LDC's, and post-conflict areas²⁴⁴.

The World Monuments Fund (WMF) represents a heritage funding approach which is structured totally differently from the WHF. Since they have no allied member states their heritage funding of heritage sites can be much more individually set, making it thus more dynamic and with their administration cost cut to a minimum. The WMF primary concern is to ensure the liability carrying out favourable international conservation works in practice. They will always be judged by everybody, from their own external financiers to the local governments that they support. The distribution money becomes their predicament and this is why a transaction transparency has to be readily available every time²⁴⁵. Their work models applied through the *Wilson Challenge* and *MOU*²⁴⁶ seem to guarantee that the closing of the conservation deals will be as a collaboration of initiated parties²⁴⁷ working in unison toward one well defined goal; to protect the built cultural heritage²⁴⁸.

Foundations which initiate and support research studies contribute every time with new findings viable for the whole cultural heritage sector²⁴⁹. These can for instance inspire new projects like the Darb al-Ahmar in the historical city of old Cairo developed in the Historic City Program funded by the Aga Kahn Trust for Culture.

Today's predicaments for internationally active foundations are the differences in tax treatments nationally²⁵⁰ which reduce the incentives for heritage funding and only an NGO status would then be the solution. Their varying objectives for heritage funding might diminish their efficiency out of some respects but at the same time offer a myriad of possibility which has to be cherished. Their main concern is nevertheless, that more of them have to become self-sufficient so that the number of private financers will increase in the future, instead of reduce.

4.5.3 NPO, self-sufficient

The definition of NPO is a self-supportive association, which at all times can promote, save and grant building conservation projects since the NPO is totally independent of external funding. Their independency, and combined with the habit of collaborating with various groups in society, ensures that the project decisions are developed according to democratic principles. This bottom-up structure might even have positive impact on future heritage value. In the case of New York Landmarks Conservancy, the numbers of initiated historical groups will always be high in a city like New York.

The decisions made in the Danish Realdania, and its branches, will then again automatically have a far greater impact on the future of built cultural heritage in the whole of Denmark. For this reason the continuous dialogue with all interested groups becomes more imperative here than elsewhere²⁵¹. The German funding norm, where a private financier can never provide more than 50% of the conservation costs, which is also the case in the WMF's Wilson challenge, eases the funding undertaking, but reaffirms also the vital dialog.

The success of an NPO association is completely reliant on the governmental financial policy on taxation and a dynamic attitude has proved to create new incentives and commitments to sustain the built cultural heritage.

4.5.4 Advocacy group, most sustainable without capital

The advocacy groups are in a sense the most sustainable of all private financers, here discussed. No capital investments are for example required for the man-hour reserves spent by dedicated local inhabitants in the advocacy groups for protect-

ing a built heritage. These *grassroots* movements living in historical districts are the core which has an exclusive and thus matchless relation to their own built environments. This natural circumstance can nevertheless be put at risk under conditions which cut off and confine the historic buildings from public access. Then again this may be restored when the legacy once more is available and will contribute to society²⁵². The more established groups, on the other hand, have their administrative costs for staff to be covered and are consequently less self-sufficient since they depend on external funding.

The capacity of the advocacy groups is yet limited, first of all as they are not possible to direct to specified purposes, which makes them unpredictable. Their motivation is built on their independency of free spirit. Secondly, they can never endow any direct funding in ready money, other than reassign other financiers by the transmitted funding or as replacement funding of manpower. Nonetheless they alone can ensure the more resilient bottom up organized building preservation approach, when encouraged by a stronger mediator, such as a non-profit organization such as the New York Landmarks Conservancy. In this way even apparently insignificant conservation issues can grow in meaning; from the local to the influential political funding level. When the middleman or the NPO structure is unavailable, the local advocacy groups will still be able to elicit and motivate opinion in society, which might encourage the local politicians to take action.

OMAS; Private financiers of heritage funding					
Financier	Origin	VP	Method	Accelerator	Sustainability
Trust	14 th C; property	H _{1,3} UN	Role model	Obligation (OA)	Not self-sufficient
Foundation	20 th C; events	H ₁ , H ₂ , H ₃	DF	Emotional, Financial	Not self-sufficient
NPO	1973's; tax policy	H ₁ UN	DF, CF	Financial (FA)	Self-sufficient
Advocacy group	Non stop; events	H ₁ , H ₂	RF, TF	Emotional (EA)	Self-sufficient, no F

Table 454.1 The four private financier groups according to the complete OMAS format. NPOs are the most sustainable financier and in collaboration with advocacy groups, they become a much consistent team.

4.6 Summary

The analysis of the private financiers of built cultural heritage revealed four groups among the 25 presented; Trusts, Foundations, NPOs and Advocacy groups. Their capacity and structure of heritage funding has here been described as funding forms, which include; direct funding, transmitted funding, replacement funding and credit funding. The span from monetary to human capital

which their backing represents, explains the private financiers' capabilities and pluralistic character.

Trusts are obliged to preserve and give access to the entrusted properties indefinitely to the beneficiary and for the National Trust (NT) embody the British people. The association's appreciation for or value preference (VP) of built heritage involves the whole H_3 UNS concept. All attained proceeds are reinvested in the business, which is why a trust never endows grants for preservation works to others, but the NT has above all been a role model for heritage financiers through the years. The legal commitment artificially ensures the value stability of the entrusted monuments and sites, therefore this sense of duty or duty-bound motivation is initiated by the obligation accelerator (OA). Enhancement of actions of duty refers to the obligation accelerator and is equivalent to legal protection with the time-bound legal value (LV) and only entails strengthening the trust agreement. The extent of the present holdings of NT is causing financial distress as well as concern for the future and the NT especially is severely dependent on external funding and voluntary labour.

Foundations are the most varied financier groups which have the capacity to apply diverse sets of goals specified in the constitution. In consequence they include the most active project participators to the passive observer, but are essential suppliers of endowment for building preservation world wide. Their commitment to built cultural heritage both involves the sentiment and rational value preferences of H_1 , H_2 and H_3 . The historic values quality the same as knowledge values H_{1-2} are directed by emotional accelerators (EA) referring to actions of threat, information and access. The rational historic quantity value H_3 of financial accelerators (FA) increase with actions of financial growth such as tax concession of national indirect funding. Foundations are in general dependent on external finance for their day to day work of direct funding for the built legacy. Their usually broader objectives in the constitutions may sometimes seem to restrain them from an efficient built cultural heritage funding strategy.

NPOs represent the most reliable financier of building conservation with their vast capacity to act as donors; launching both direct- and credit funding. The NPOs here described also carry out work as proprietors, administrators or initiator due to their broad professional expertise. The association's rational value preferences are H_3 UN which therefore are possible to enhance by financial accelerator (FA) with actions enabling positive revenues for reinvestment in the built heritage. When the national finance policy agrees to indirect as well as credit funding new investment options such as easements can grow, as exemplified by the NLC. The funding efficiency of NPOs may call for endowment limitations when not standing in proportion to the field of operations to ensure democracy. The success of NPOs depends on a positive political approach to tax concessions,

which has proved to develop new funding forms. The option also increases the bottom-up perspective of funding where finance commitment could incline new groups in society to sustain built cultural heritage.

The advocacy groups are more or less well organized promoters of building preservations by their transmitted and replacement funding of built heritage. As inhabitants living in historical cities, they may have the ability to exert immense influence on political decisions; they can be the angry grassroots taking actions to protect historic buildings in their vicinity. When organized in alliances with private financiers to promote preservation, they enable the sustainable bottom-up perspective or may settle for only launching informative periodicals. Advocacy group value preferences are limited to the sentimental units of H_1 and H_2 thus driven by the emotional accelerators (EA). Actions of access to built heritage by public use are value enhancing, in the same way as new channels for information on heritage buildings or sudden demolition plans as action of threat. The advocacy group belongs to one of the most sustainable of the private financiers since it is based on transmitted and replacement funding, at the same time it is unreliable due to the incentive call for independency.

Finally, the assumption from heritage economics in Step 1, Study 1-2, indicated that the influence of the financier directed the process in building conservations and might relate to the fact that their incentives for funding are individualized because their *value preferences* (VP) differ. Private funded projects for this reason were found to represent; *brief processes*, included *all kinds of buildings categories*, the *acceptance of adaptation for new use* was high and the *aim to do the job* was vital. This conjecture has consequently been proved confirmed and it even indicates it is the VP individuality which exists within the private financier group, which all finally strengthened the accuracy of the analyse method, which has been applied.

A private financier has no obligation to provide continuous support and is often regulated on a yearly basis hence limiting the project length, but there are many of them. No legal bindings to specified building categories exist however; the future prospect of the investment is if possible always considered as adaptation for new future use, to enable revenue, which is why the professional team has a more tight time schedule than the publicly funded projects. Publicly financed project can certify specialists for assignments, without any open purchase, hence this might reduce the incentives for expert consultants to carry out brief projects or cut costs. The private financiers' capabilities and pluralistic character indicate that *actions*, such as external policy decisions nationally, should take measures to ensure heritage funding from the whole group of private financiers, by inducing both emotional and financial accelerators.

Denmark has now once more proved to have a strong private orientated heritage funding, especially with the recent NPO establishment, both in comparison to size and geographical domicile in Scandinavia. This position was revealed already during Study 1²⁵³ as Denmark then alone represented a private-public heritage funding policy²⁵⁴, a definition which is further described in the next chapter: Acquiring public funding.

Notes chapter 4

1. See Appendix 1.
2. See Appendix 1.
3. Some of the financiers here discussed actually receive public means, but still they consider themselves as politically independent in their decisions. This issue is discussed under the heading “Sustainability” later in the chapter.
4. From architectural style to condition of constructions, see chapter 1.
5. See chapter 2.
6. Miss Octavia Hill, Sir Robert Hunter and Canon Hardwicke Rawnsley set up the National Trust. Similar movements were established in other countries as well. In Sweden for instance A. Hazelius and G. Karlin founded two among the first European open air museums; Skansen in Stockholm and Kulturen in Lund.
7. Demolition of manor houses in the UK took place in the 1930’s, see Hunter (1996, p. 99).
8. The National Land Fund got established in 1946, TNT (2004, p. 4).
9. The financial legal acts of significance were approved in 1953, 1956 and 1973, *ibid* (2008, Web).
10. The revenues on the sale of National Trust products, from card games to literature, bring but a minor income for National Trust. Its actual gain is most likely as a commercial tool which brings publicity for their holiday renting of houses.
11. About 600 miles of coastline, see TNT (2004, p. 23).
12. More than 300 in all National Trust, (2008, Web).
13. The Council Re-elected every three years 26 elected members and 26 appointed from kindred bodies, *ibid* (2008, Web).
14. “To make every pound count we try to manage our affairs efficiently as the best business so we have radically reformed the way we operate. And we must take decisions quickly, transparently and accountably to give people confidence in the way the charity is run and this is why we have introduced the most far-reaching governance reforms in the Trust’s history.”, quotation from Sir William Proby, Chairman of the National Trust, *ibid* (2008, Web).
15. Forestry, fisheries, environmental goods and services, *ibid* (2008, Web).
16. National Trust claims that;” for each new job that NT creates, this will generate up to nine additional employments in a region, *ibid* (2008, Web).
17. “*Our members are foremost white, elderly middleclass and that’s a problem we have to deal with in the future*”, quotation from Northey (2004, interview).
18. About 30% and 50% of the income is allocated on routine maintenance, see TNT (2004, p 21.f).
19. See Krichbaum (1994, pp. 99-104).
20. Priority to social matters, education, regional planning and conservation of natural and architectural heritage, see *ibid* (1994, p. 99ff).
21. Facts from 2003, *ibid* (1994, p. 99ff) and 50 nations in 2010, Council of Europe (2010, Web).
22. At the Vienna Conference.
23. See Krichbaum (1994, p. 102f).
24. Joint Declaration on cooperation and partnership between the Council of Europe and the European Commission 1987. However, the Structure Funds were instigated in Treaty of Rome 1957 to support regional growth by social, agricultural programs. More capital and reforms were made in 1973, 1975 and 1986. The major expansion was during 1988-1999, now including as well Framework Program for building preservations, Katsarova (2009, Webb).
25. Ljubljana Process 2008, the Slovenian Presidency inspired to launch the project, Council of Europe (2008, Web).

26. See TNT (2004, p. 36).
27. Ibid (2004, p. 36).
28. Improve the supply of irrigation and electricity for the whole of Egypt, High Dam, World Heritage Fund (2008, Web).
29. Two temples were dismantled and reassembled 60 meters up, upon a sandstone cliff and covered with an artificial mountain, but in identical relation to the sun, *ibid* (2008, Web).
30. The 50 nations collected 50% of the costs which was 40 million US dollar, *ibid* (2008).
31. The Convention Concerning the Protection of the World Cultural and Natural Heritage.
32. See Article 11 of the Convention, (2008, Web).
33. Quotation from Valanchon, N. (2008, Interview).
34. Such as Flemish Funds-in-Trust 2000, France-UNESCO Cooperation Agreement, Japanese FIT 1989, Netherlands Funds-in-Trust 2004 and Spanish FIT 1982, World Heritage Fund (2008, Web).
35. The partners have to agree to WHF's stipulated partnership criteria, PACT, *Ibid* (2008, Web).
36. From hands-on conservation projects to awareness campaigns all over Sweden and these were initiated by the heritage authority.
37. Riksantikvarieämbetet or the RAÄ.
38. Johansson, B. OH. (2008, Interview).
39. The new chairman was Catherine Plause von Arnold who encouraged organizations such as the Villaägareföreningen to start advertising in the periodical, *ibid* (2008, Interview).
40. "We were aware of having to select what adds that could be accepted to use for building conservations, since we had to approve of all the products which were advertised in our periodical", quotation from Johansson, B. OH. (2008, interview).
41. Publicly funded by 30%, membership fees (69%) and the profits from their own events (1%), Bylander, L. (2008, interview).
42. About 300 BPTs (building preservation trusts) exists in the UK and they represent first of all the local communities. A BPT can be set up for an individual town, counties, special types of buildings or just for one house, Architectural Heritage Fund (2008, Web).
43. Eagle Workshops and Exchange Buildings in Sunderland has brought in investment on more than £ 6 million and helped to create 75 new jobs, *Ibid* (Web, 2008).
44. No single private owners are entitled to funding, only organizations, *ibid* (2008, Web).
45. The preserved edifices are resold after project completion, *ibid* (2008, Web).
46. Willy Messerschmitt was an Aircraft constructor during WW 2, and of sawing machines. After 1950 he designed prefabricated houses, see Ritter v. Srbik (1997, pp. 49-52) and Messerschmitt Stiftung (2009, Web).
47. Shares were sold to Daimler-Benz, *ibid* (1997, p. 50).
48. The architect of *die Neue Wache* (New Guard House) in Berlin in 1816 was Karl Friederich Schinkel, *ibid* (1997, p. 50).
49. MF considers that their strong commitment in the projects is one of the major reasons for their success, Messerschmidt Stiftung (2008, Web).
50. Projects like the Charles Bridge in Prague and other significant sites in Poland, The Czech Republic and Hungary, Transylvania and South Tyrol in Italy, *ibid* (2008, Web).
51. „Damit Vergangenheit ein Zukunft hat“.
52. The federal building curator in Hessen was professor Kiesow, Thomas, U. (1999, interview).
53. *Ibid* (1999, interview).
54. In the new states; die Neue Bundesländer, the historical villages, churches, castles, city houses and town walls were very neglected and at risk. The larger estates systematically for ideological reasons had been adapted to temporary apartments for Germans who had fled from the east territories, which became Polish after WW2, see Skarin Pålsson (2001, p. 113f).

55. The *BVS* money; Bundesanstalt für Vereinigungsbedingte Sonderaufgaben, Thomas, U. (1999, interview).
56. *Ibid* (1999, interview).
57. Over one thousand pupils have studied cultural monuments on site, taking part in restoring and documenting the monument, DSD (2008, Web).
58. Skarin Pålsson (2001, p. 113f).
59. The „D“ refers to Denkmal; cultural or historical monument, Deutsche Stiftung Denkmalschutz (2008, Web).
60. An investment of more than 370 million Euros and 170,000 benefactors have made donations, *ibid* (2008, Web).
61. *“The financial situation is critical for all German states 2008, but for heritage funding this begun already around year 2000”*, quotation from Bednorz, M. (2008, interview).
62. Quotation from Deutsche Stiftung Denkmalschutz (2008, Web).
63. Periodical, name campaign and forms of share holding.
64. *“In spite of the fact that tax exemptions are available on donations up to 20 000 Euro in Finland”*, quotation from Kolmanen (2008, interview).
65. Through 12 regional offices, Arts & Business acts as a meeting place where businesses and arts organisations come together to create beneficial partnerships, Arts & Business (2008, Web). The Swedish branch was established through Svenska Industriförbundet, Bolgar (2008, interview).
66. A precedent verdict was approved in the Government Court 2000, Pharmacia Upjohn sponsoring of the Royal Opera, see FKN (2001, p. 13).
67. See Temo (1999) Kultursponsring i Sverige and FKN (2001).
68. Bolgar (2008, interview).
69. *Ibid* (2008, interview).
70. FKN has 270 members from the business world and the cultural sector, Föreningen Kultur och Näringsliv (2008, Web).
71. Storebrand and Forsikringselskapet UNI, UNI (2008, Web).
72. *Ibid* (2008, Web).
73. In the federal State of Brandenburg the palaces signified the most prominent architecture and artistic skills, thus today an important cultural heritage.
74. DDR is short for Deutsche Demokratische Republic.
75. Quotation from Klemisch, J. (2004, Interview).
76. In some parts of Germany the old families had to pay a large sum of money, but they could never retrieve the land which once was theirs and belonging to the estate, for agricultural use. This was the case on the island of Rügen in 1996.
77. There is an immediate need for; safeguarding, wood preservation measures, stabilization, problems with moisture penetration and repairs of the garden areas, see Skarin Pålsson (2004).
78. The redevelopment costs are equivalent to investments, so rents from leaseholders for this reason is low, 5,50,- € m²/month. The new utilizations of the estates will ensure the maintenance of the castles as well, Klemisch (2004, interview).
79. About 2, 5 million Euro, *Ibid* (2004, interview).
80. Gobbelt (2009, interview).
81. The Co-founders have been the authorities in the counties, the municipalities and representatives from trade and industry, Norsk Kulturarv (2008, Web).
82. See Mousette (1997, pp.42-43).
83. Its capital is more that 30 million Francs, *ibid* (1997,p. 42f). A total of 15 companies regularly support the foundations, such as; AXA, Le Credit Agricole, Devanlay, La Fondation EDF and L'OREAL, Fondation du Patrimoine (2008, Web).

84. It enables to a tax exempt of 50% for restoration works. In 2005 over 4000 Labels were awarded throughout France. The FDP is the only organization in France that is entitled to use the label system for tax deductions, *ibid* (2008, Web).
85. The label is only valid for five years during which the maintenance works need to be finished. The owner chooses his own craftsmen and consultants, but all works have to be approved of by an expert, *ibid* (2008, Web).
86. *Ibid* (2008, Web).
87. French government created new legal forms called “firm foundations”, only open for companies. These foundations need to last five years and they cannot own real estates. The founder is committed to finance the firm foundation with at least one million francs (1997). Nine years ago there were at least 50 of this kind in France. The same rules are applied for associations, but only foundations may own buildings, see Mousette (1997, p. 43). The Foundation de France was established in 1972 by French government to shelters more than 100 foundations with the purpose create an effective use of money, *ibid* (1997, p. 43).
88. Foundation du Patrimoine (2008, Web).
89. Andersen (2008, interview).
90. The name of the bank is the Danish bank.
91. Danske Bank bought the association, Andersen, C. (2008, interview).
92. The chairman was at first mr. Möller. At an early stage RD made an evaluation of the works of National Trust, *ibid* (2008, interview).
93. *Ibid* (2008, interview).
94. In 2006 they launched 255 focus projects, Readania (2008, Web).
95. The heritage group consists of 10 persons and only three of these are architects. The others are legal or financial experts, Andersen (2008, interview).
96. The RD’s staff can suggest what architects that could be suitable for certain building conservations, but they can only give advice, *ibid* (2008, interview).
97. Guidelines on building conservation set up in the ICOMOS charters, *ibid* (2008, interview).
98. In 2006 RD invested in 54 strategic flagship projects, and one of the most important for the region 2008 was the Kronborg bastion in Helsingør, Readania (2008, Web).
99. Andersen (2008, interview).
100. Similar relevant projects are; Future estates, Farming houses, The city environment, *Ibid* (2008, interview).
101. Such as The Danish Architecture Centre” or Dansk Arkitektur Center.
102. *Byggningskultur Danmark* is the former Byggningskulturellt råd. Today there are 31 members of this organisation which all are active in the field of building conservation. Realdania have financed the Byggningskultur Danmark for five years, but from now on they have to be self-sufficient, Andersen, C. (2008, interview).
103. Tax, philanthropic activity, administrative costs, Readania (2008, Web).
104. Andersen (2008, interview).
105. In Danish; Velux fondet, Sonning fondet, Augustinus fondet and Rockwool fondet. The many established funds in Denmark could be due to the fact that they have low taxation.
106. The absence of signs announcing themselves as financiers at building sites can be because it must never be understood as if they would be sell their own products, when funding building conservation projects, Maegaard Nilsen (1997, interview).
107. The title is *Kraks fonde og legater*. They published books and CD’s on foundations, long before the Internet was used.
108. Kraksbutik (2009, Web).
109. The Associations main purpose is fundraising from the private sector for individual heritage projects. In Germany schools can have a Förderverein as well which could consists of former students, Förderverine (2009, Web).

110. DDR; Deutche Democratic Republic, such as for the Rossewitz palace, see Skarin Pålsson (2001, p. 113ff).
111. Initially there were 50 paintings in Samuel Kress's private collection, Samuel H. Kress Foundation (2008, Web).
112. The collection and distribution of works of European art to American museums and study programs for professional expertise in art history and art conservation, *ibid* (2008, Web).
113. The name World Monument Fund has been used since 1985, World Monument Fund (2008, Web).
114. See WMF (2007).
115. All other donors as well used the UNESCO bank account for their contributions and thus gained 20 million dollar in this way, which was equivalent to 18% of the costs. This could go directly to the maintenance work, Burnham (1997, p. 87).
116. The WHF has assisted 450 conservation projects in 90 different countries, WMF (2007).
117. WMF (2007).
118. Projects for example in Mexico City, at St Pauls Cathedral or on Route 66, WMF (2007, p. 4f)
119. Quotation, see *ibid* (2007, p. 8). Additional future risks to built legacy pollution, culture tourism, urban sprawl, the need for energy, political discord and armed conflicts are, WMF (2007, p. 4).
120. During 2006, WMF supported heritage projects accordingly: Asia (19%), North America (12%), South America (6%), Central and Eastern Europe (23%), Western Europe, (28%), Middle East (3%), North Africa (6%), Sub-Saharan Africa (1%), and Oceania (1%), *ibid* (2007).
121. In this way local financiers become aware early on and get involved in the conservation projects, Weber (2008, interview).
122. A total of 29 million dollar, WMF (2007, p. 4).
123. *"In Bosco, northern India, the whole village assisted by transporting stones from a local quarry to the building site, by forming a human chain. The authority asked is if this local support could be transferred into or regarded as pecuniary means. We accepted the challenge and designed a model that converted the working hours to money"*, Weber (2008, interview).
124. WMF's involvements around the globe has been; The Americas, 30 ongoing projects, Asia: Benjing the redevelopment due to summer Olympics. The heritage threats in Asia are over-population, natural disaster, climate change, lack of resources and an unsustainable tourism. In Europe WMF has been active for 40 years in 70 projects. Here the threats are the fact that the nations funding is insufficient to care for the reassured sites, WMF (2007, p. 4).
125. The State Boards of Antique and Heritage, BAH, *ibid* (2007, p. 12).
126. The WMF support per site covers from \$10,000 to \$1 million, but it ranges between \$ 20,000 and \$ 100,000, World Monuments Fund (2008, Web).
127. From 2,9 millions in 1997 to \$15,4 millions in 2007. Expenditures on programs and support services in 2006 were \$17 million and 87%, or \$ 14.7 million went to program services. Totally 171 conservation projects were funded, with 24 receiving more than \$100,000 each, *ibid* (2008, Web).
128. Approximately 86% of WMF's expenditures go to field conservation projects, education and outreach programs. The remaining 14% is for fundraising, administration and general overhead expenses, WMF (2007, p. 6).
129. *"The organizations agility in the field and its ability to cut across geographical boundaries...to forge partnership with fellow non-governmental organisations, local communities and governments.....WMF is better able to ensure the success of every projects it undertakes"*, quotation from W. L Lyons Brown, Chairman of World Monument Fund, *ibid* (2007, p. 5).
130. In 2007 this group contributed with 61% of the endowments, *ibid* (2007 p. 36).

131. In the 1880's Industrialization and population growth had made the city unattractive for the New Yorkers, Breen and Harrera (2008, interview).
132. Alexander Hamilton was one of the founders of New York Landmarks Conservancy, *ibid* (2008, interview).
133. Building conservation is "green", Quotation from Breen (2008, interview).
134. In 1976 was the bicentenary of the US, 300 year of the American Constitution. This jubilee evoked an historical consciousness that helped develop a network of preservation organizations; private, local and national, Burnham (1997, p. 85).
135. Historic Charleston Foundation was established in 1947, Historic Charleston Foundation (2009, Web).
136. A New York senator in 1970-2003, Breen and Harrera (2008, interview).
137. *Ibid* (2008, interview). The New Yorker is an influential news magazine printed in New York.
138. From planning to completion, Breen and Harrera (2008, interview).
139. Architect offices, craftsmen and suppliers that they are pleased to work with. In the 1980s during the campaign *Save New York City* Polish and Italian immigrants came with an excellent knowledge of masonry and plaster, which had been long forgotten in the US, Harrera (2008, interview).
140. In 2003 the fund allocated more than 12 million U.S. Dollar for loans and grants, NLC (2003).
141. The religious properties are the most vulnerable building type and are not entitled to public grants, and the parish can not afford the renovation since they have no extra money other than perform services, this is why many churches are demolished or sold, Burnham (1997, p. 86).
142. Over 800 religious properties have received support until 2003, NLC (2003, p. 9).
143. *"To rescue a building from decay or demolition the most efficient way is to advocate it by listing, to establish easement comes second and then you have grants or loans on third place"*, Breen and Harrera (2008, interview).
144. The owners financed the fund, *ibid* (2008, interview).
145. For architects, craftsmen, suppliers and so on, *ibid* (2008, interview).
146. We commissioned a firm for 35 000 dollars to make supporting constructions for the buildings on Ellis Island, *ibid* (2008, interview).
147. *"The construction engineer Zillman was assigned to investigate if a hoist would be possible. The total weight of the concrete stair was 60 tons. Everyone said it would be impossible to move it and that it would fall apart but he proved them wrong"*, *ibid* (2008, interview).
148. In New York City there are 21 000 listed buildings today, *ibid* (2008, interview).
149. *Ibid* (2008, interview).
150. Quotation from Peg Breen, *ibid* (2008, interview).
151. Heritage Canada Foundation (2008, Web).
152. See Steiner (1997, p. 94).
153. Mr. Getty's personal estate was passed on to the Trust in 1982, *ibid* (1997, p. 94).
154. The divisions are for instance; The Getty Conservation Institute, the Getty Research Institute, Getty Leadership Institute and The Grant Program, *ibid* (1997, p. 95).
155. J. Paul Getty Trust (2008, Web).
156. More than 544 endangered sites in 117 nations, WMF (2008, p. 5).
157. Governments, local and international preservation groups, nongovernmental organizations, and private individuals, World Monument Fund (2008, Web).
158. Approximately 75% of the listed sites are now out of threat, *ibid* (2008, p. 4).
159. The sum was 3, 1 million U.S. Dollars in 1996 and 17 millions in 2006, *ibid* (2008, p. 4).
160. The WMW grants of 49 million Dollars have induced additionally 125 million Dollars more from other financiers, *ibid* (2008, p. 4).

161. These changes are also threatening the built cultural environments such as the Scotts expedition hut in Antarctica, World Monument Fund (2008, Web).
162. The association was registered in Geneva, Switzerland, Aga Kahn Trust for Culture (Webb 2008).
163. The Aga Kahn foundation arranged a conference; The expanding Metropolis discussing the urban growth of Cairo, *ibid* (2008, Web).
164. Flemish Funds-in-Trust (2008, Web).
165. Just like the Swedish founder of the Kulturen museum in Lund Georg Karlin did, by moving threatened vernacular architecture to open air museums.
166. More than 40% of Sweden's historical city centres were demolished between 1960 and 1970 and 20 towns lost even more then 60% in the residential districts, see Johansson (1997, p. 11f).
167. The devastating flooding of Venice in 1966, see discussion above.
168. Egyptian government announced their plans to construct the High Dam.
169. WMF's cooperation model has proved to be successful with the Kreiss foundation and to reach the local grassroots nationally.
170. Represented by New York Landmarks Conservancy and The Heritage Canada Foundation.
171. Founded in 1947, Historic Charleston Foundation (2009, Web).
172. Early scientific studies to interpret value assets in National Parks in financial terms by Hotelling 1949, underlines this early development.
173. "*When it comes to listing the way that New York Landmark Conservancy works, prove that suggestions come primarily from "below", that is, the 50 historical groups*", Breen and Harrera (2008, interview).
174. Conservation projects such as the Lutheran church in Lithuania, Kosciol Mariacki in Poland, but also Swedish funding of the Palme Estate and Swedish church in Estonia.
175. This development is excluded from this study, though Lithuania and Poland were included in Study 1, but their change when it comes to heritage funding is a most relevant issue for future studies.
176. See Bogdan (2003, p. 67ff).
177. North- and West European countries, see Hondius (1997, p.18), including Denmark, Sweden, Finland.
178. See note 176.
179. Developed on prejudicial grounds in the 1400th century that enabled the king to hand over decisions to his secretary, the Lord Chancellor, that established the Court of Chancery, Bogdan (2003, p. 97).
180. *Ibid* (2003, p. 97f).
181. A proprietor is assigned to supervise that a deal is kept, see Kearns (1997, p. 21f).
182. If the legal estate comes in the hands of a genuine purchaser only for value, with no interest of the beneficiary. The "Definition of Trust is being vague", quotation from Kearns (1997, p. 21f). Bogdan (2003, p. 100).
183. Certainty in words, certainties in subject and certainty in object, Kearns (1997 p. 21)
184. Trusts set up for the benefit of the public is a charitable and private trusts only valid for certain individuals have a non-charitable purpose, *ibid* (1997, p. 22f).
185. Low stamp duty, remission from VAT, rates to local authority. All income for the charitable trust is exempted from tax; Income-, corporation-, national insurance surcharge and capital gain tax, *ibid* (1997, p. 21f).
186. See chapter 3.
187. Continental Europe and others under the civil law legislation are Russian Federation, Latin America, parts of Africa and Asia. Properties and foundations are related to alms, see Hondius, (1997, p. 17ff).
188. See Bogdan (2003, p. 82f). Denmark, Sweden, Finland, Norway are of interest for this study.

189. In 14th Century for example king Magnus Eriksson's County laws in Sweden.
190. Wealthy citizens established company foundations such as Rockefeller, Bosch, Nobel, which submitted to public law under legal control of society, see see Hondius (1997, p. 19).
191. Exemptions from tax on capital, real estate and sales tax, see Burnham (1997, p. 86). In some nations like Sweden tax-exemption can regulate the mission of foundation by establishing what areas are considered to be of common good; education, defence, poverty, science and for unprivileged children.
192. Realdania has ten employee with three architects and the others are lawyers, economists or administrative personal, Andersen (2008, interview). The NCL has 15 employed, two are architects and two building conservators. The others are lawyers, economists and administrative personal, Breen and Harrera (2008, interview).
193. Facts and impressions of the NLC and Realdania facts are based on personal interviews.
194. The SBF; Svenska byggnadsvårdsföreningen, already mentioned, is somewhere in between providing information and practical education on built heritage matters.
195. To the author's knowledge, it has not yet been practiced in Europe, for heritage funding.
196. *"Limitations in accessibility would imply that whole idea of being a Trustee lost its purpose. The more visitors the higher are the costs for repair and maintenance. Some estates can not take frequent tours and not be uses in the real sense of the word"*, Northey (2004, Interview).
197. Membership fees, HLF, EH and European Commission, *ibid* (2004, Interview).
198. The National Trust produces and sells a great number of goods over internet and in their local offices.
199. See Hondius (1997, p. 19)
200. When regulation of the future measures permits that an adaptive re-use can be made.
201. See chapter 6.
202. *"A dilemma for the member states with higher GNP is that they will never receive any grants from the WHF themselves, but remain its mayor financier always"*, Turtinen (2008, interview). See chapter 5.
203. During a time period of 30 years from 1936 to 1968, the number of foundations in the United States increased 70-fold, but doubled between 1968-98, Hondius (1997, p. 16).
204. The Partnership Programs. To encourage funding through the French Partnership Program, the French government made an offer to owners of listed buildings that public means would contribute with 40% of the conservation costs if the owner could match the offer with the additional 60%, Burnham, (1997, p. 87).
205. Readania is an umbrella organisation of Realial, BD, while New York Landmarks Conservancy's management has more a character of one body. However, both of the NPOs commission architectural and constructional consultants from the outside.
206. Deutsch Stiftung Denkmalschutz foundation has developed an efficient cooperation with for instance television as well.
207. Andersen (2008, interview).
208. In 2007 the palace of Meseberg was let out to the German government as a guest accommodation, Messerschmitt Stiftung, Meseberg (2009, Web).
209. Breen and Harrera (2008, interview) and TNT (2004, p. 34).
210. In Historic Charleston the preservation group, the Historic Charleston Foundation (HCF) purchased an historical property in the city centre which they renovated and resold it with a profit as museum that was reinvested in a purchase of a second building in the area, Burnham (1997, p. 86).
211. *"Authorities should set up Revolving Funds..(..)by providing local authorities or non-profit making associations with the necessary capital..(..)to areas where such programmes can become self-financing..(..)because of the rise in value accruing from the high demand for such attractive property"*, quotation from The Declaration of Amsterdam 1975.
212. A non-profit does not pay tax on the earnings when they sell a historical property.
213. The tax-exempt on 5 million U.S. Dollars profit, NCL (2003).

214. Profit could be set aside by New York Landmarks Conservancy to a permanent endowment to support a city-wide facade renovation program. Additionally a special emergency fund helped stabilize endangered religious properties, Breen and Harrera (2008, interview).
215. To rescue a building from decay or demolition the most efficient way is to establish a listing, an easement comes second and then you have grants or loans in third place, *ibid* (2008). Easements could as well be set up for a landscape or archaeological sites.
216. Under the Internal Revenue Service's (IRS) Qualified Conservation Contribution, the owner can receive an income tax deduction equivalent to the value of the rights given to the Conservancy, New York Landmarks Conservancy (2008, Web).
217. The degree of restriction may range from the preserving of interior details to prohibiting all development, NCL (Webb, 2008).
218. The Conservation Society of San Antonio purchased facade easements from owners of commercial properties in the city centre. The sale of easements gave the owners enough to preserve the facades, just as the buildings, according to the new restrictions from the authorities, Burnham (1997, p. 86).
219. The owner is entitled to obtain a higher rent if it contributes to the well-being of the community, *ibid* (1997, p. 86).
220. The South Street Seaport, Meatpacking district and the most recent High Line project.
221. The Architectural Heritage Fund (AHF). A new established BPT receives assistance from AHF, from advice to grants, see Architectural Heritage Fund (2008, Web).
222. Burnham (1997, p. 86).
223. *"The two private groups on Ellis Island today are Save Ellis Island and Ellis Island. They are working in cooperation with National Park Service, the public body, in favour for the rest of the uncompleted buildings"*, Garrett (2008, interview).
224. For a cost of 100 dollars families could list names on metal plates of their ancestors who once emigrated to America and the plates were then fixed to the walls. This campaign alone brought over 100 million US Dollars to the project, *ibid* (2008, interview).
225. Ellis Island was a quarantine holding centre and in use until the 1954. Celebrities, with immigrant backgrounds, were taking an active part in the advertising campaigns for fund raising. SLEIF applied for funds from different sources, they licensed out campaign symbol, sold licensed products and informed the public. Even modest contribution came from school children and families, Garrett (2008, interview).
226. *Ibid*, (2008, interview).
227. See chapter 1.
228. The relation between accelerator and H₃UNS value concept, presented in chapter 3.
229. Unexpected circumstances such as the flooding in 1966 Venice for WHF and urgent move of the Abu Simbel 1964-68 for WHF.
230. An the simulations development of civil aviation.
231. German television is promoting heritage funding to Deutsche Stiftung Denkmalschutz with programs such as *Bürger, rettet Eure Städte* (Citizens save your towns) and concerts in Deutschlandfunk *Grundton D* (D stands form Denkmal; monument), Deutsche Stiftung Denkmalschutz (2008, Web). The British equivalences are just as essential for the Heritage Lottery Fund and English Heritage with programs like *Restoration*.
232. See p. 151. RD and NCL.
233. *"The climate challenge is affecting the coastline with villages that erodes and since NT owns over 600 miles this will escalate to a gigantic problem in the future"*, Quotation from Northey (2004, interview). (10 000 meter = 0, 62 miles)
234. The membership fees are of vital importance for NT and the trusts exist for the general public, which is the idea with the Trust. Private endowment in all forms from money, as grants from private persons on 5-10 millions, or commodities such as buildings, *Ibid* (2004, interview).

235. Problems might arise, when the war generation is deceased and with them the collective memory of the National Trust development.
236. Quotation from Northey (2004, interview).
237. (DSD) Deutsche Stiftung Denkmalschutz's financial situation has worsened ever since their additional funding stopped, which DSD had received ever since 1989, Gerber (2008, interview). When Germany was reunited DSD did received 50 million DM during eight years, money which used to belong to the communist party, Partei- und Massenorganisationen the former DDR, Thomas (1999, interview).
238. The finance support from the television lottery Glückspirale used to be stronger, but less lottery tickets are sold in the former East Germany, which has a lower population rate, Gerber, H. (2008, interview).
239. Political missions of uniting nations, re-establish borderlines or educations are mixed with the wish to preserve built cultural heritage.
240. In 2007 there was a decrease in revenues for the World Heritage Fund since some member states have neglected to pay their membership fees regularly. Some countries have not even paid their dues in 15 years and WHF for this reason, loses 200 000 Euro in average annually, Valanchon (2008, interview).
241. The training sector covers 16,8% of the WHF budget and to improve the skills in building conservation involve a range of activates, from scientific research to public information, World Heritage Fund (2008, Web).
242. The insufficiency in financial support of the WHF actually creates a multi-donor context.
243. See UNESCO Report (2006, p. 5ff).
244. *"Since the WHF financial assets are limited to three millions Euro a year, the priority order on the World heritage danger favour heritage sites in LDCs; The least developed countries"*, Valanchon (2008, interview).
245. *"Some of the predicaments concerning the distribution of grants internationally are creating transparency when having money coming in and out of an account"*, quotation from Weber (2008, interview).
246. A memorandum of Understanding, MOU, has to be signed before the collaboration can begin, which can sometimes take long time, ibid (2008, interview).
247. The WMF collaborate with the public bodies and local financiers.
248. The "Wilson Challenge" demands "Match-making" were the grants is distribute on a one to one basis, for private proprietor, or one to two , when dealing with public authorities. This calls for an active recipient from the grass roots to the authorities, Weber (2008, interview).
249. The Deutche Stiftung Denkmalschutz and Architectural Heritage Fund have established that new investments made in deteriorated city parts or building stock has a positive impact on a whole community and the preserved buildings are increasing in value.
250. All foundations are the countries different tax treatments and absence of fiscal incentives for trans-frontier giving, Hondius (1997, p. 19).
251. The Realdania influence on the heritage sector is by some considered to be far too strong in Denmark. The efficiency of both NPOs indicate that the dominance in New York will be far less with a population on 18,6 million in comparison to the 5,4 millions Danes in the whole of Denmark.
252. This was the case for New Maglarp Church.
253. The Danish building conservation process was equivalent to a "complete" project, Skarin Pålsson (2001, p. 268).
254. The nations at the Baltic Sea in the study were Lithuania, Poland, (former) East Germany, Denmark and Sweden.

5. Acquiring public funding

5.1 Introduction

Public finance assigned for the protection of built cultural heritage in democracies of today emanates from and mirrors the recognized national cultural policy. This indicates that its present features might not be the ones applied previously, nor that it will remain unchanged in the times to come, since public subsidy for heritage always relies on the total public items of expenditure in financial plans. In Study 1¹ two main features of public funding were identified; the public and the private-public direction, describing the extent of collaboration, by sharing heritage expenditures with the private finance sector. To investigate what regulates public funding generally, but also what has been decisive for the two approaches practiced specifically, six countries have been analysed according to the OMAS format in this chapter. The countries selected correspond to those employed in Study 2 as well². In this case Finland, Norway and Sweden represent the public direction, while Denmark, Germany, like Great Britain, reflect the private-public one. Moreover the assumption set in the initial study has been tested, i.e. signifying how public funding might generate obvious side effects, which in turn influence the built heritage.

5.2 Origin

Public funding is organized by two parties; the politicians in government and the heritage authority expert at the National Heritage Boards, so their characteristics need primarily to be investigated. Additionally, the reason for the two funding directions applied in nations; the public or private-public, has also been examined from two angles – it could either be due to politics, as revealed in society structures, or influenced only by how working methodology of the heritage authorities is set up.

First of all a potential political impact in the nations was evaluated from four standpoints; *Historical relations*, *War intrusion*, *European cooperation* and *Present policy*. Secondly, any unique feature among the authority experts explaining the national directions, was assessed from three perspectives; *Finance solidity*, *Funding*

claims on others and *Financial reforms*. All traceable group characteristics found, based on either political or authority grounds revealing national identity, were then discussed.

5.2.1 Politicians and heritage expert authorities

As ancient descendents from kings and governing councils, politicians of today are the elected representatives who are *temporarily* involved in the most vital decisions with influence over the distribution of national public funding. This heterogenic group, with a broad knowledge base of academic as well as practical experiences, is elected on their merits as representatives of the currently most accepted political ideology of a nation. Their broad involvement in domestic and foreign affairs forces them to submit to the expertise of the civil servant experts and this turns them into laymen when it comes to built cultural heritage issues. A political decision concerns today's as well as future societies and its previous impact is distinguishable in the historical past.

The heritage authority expert was employed in the centralized and stable state departments of culture and built heritage, which in Europe were set up by the end of the 19th century. Authorities in the public body are historical experts with profound proficiency in the field of built cultural heritage³. These civil servants have a *steady* employment but, on the other hand only a varying influence over the allocation of public funding for built cultural heritage. Their ability to act out, according to their individual convictions regarding built cultural heritage issues, will always depend on and be circumscribed by the present cultural policy nationally. This affects their degree of influence over the allocation of public resources, but they are nevertheless distinguishable by the work strategies which they apply within the department.

OMAS; Public financiers of the built cultural heritage					
Financier	Origin	Methods	VP	Accelerators	Sustainability
Politicians	layman temporary strong				
Authorities	expert stable weak				

Table 521.1 *Origin politicians and authorities according to the OMAS format, here (O).*

5.2.2 Distinctions of national policy

5.2.2.1 Public direction

The Finnish reliance on Sweden since the 12th century came to an end when Russia seized power in 1809⁴. After 108 years Finland finally gained their independence and the new nation adapted to a republican form of government⁵. The two world wars affected the nation severely due to their exposed position geographically which increased the number of armed conflicts. Their eastern neighbour; the Soviet Union, intervened regularly politically during the 20th century, but the Finnish membership in the Council of Europe and later, the European Union⁶ tied the nation closer to Western Europe. Politically the coalition of the Social Democratic Party and Centre Party has been in dominance and the first female president was elected in 2000⁷.

Norway had historical ties to Denmark until 1814 when they gained sovereignty and the Norwegian constitution was written⁸. The personal union with Sweden which followed was dissolved in the beginning of the 20th century⁹. The German invasion during Second World War in 1940 caused human and physical casualties. Norway became early on a member of the Council of Europe and later also a member of EFTA, but is still unattached to the European Union¹⁰. Today Norway is a parliamentary representative democratic constitutional monarchy with a red-green, Social democratic- Environmentalist government¹¹.

Sweden was an independent and unified country since the Middle Ages, which developed a centralized administration in the 16th century¹². The parliamentary system was introduced early on, in 1719, and the nation is today a constitutional monarchy with a parliamentary system of government. The nation could remain neutral during the First and the Second World Wars and Sweden has actually not suffered warfare for 200 years. Sweden became soon a member of the Council of Europe¹³ but rather late a member of the European Union, in 1995. The Social Democratic Party has influenced Swedish policies since the 20th century¹⁴ but the present government has been a right wing liberal coalition since 2006.

5.2.2.2 Private-public direction

Denmark has been unified since the early middle ages and developed a constitutional monarchy with a parliamentary system of government. The country was invaded during World War II by the German army in 1940 and was for this reason exposed to human as well as physical losses. Denmark has been in the Council of Europe since the 1940's¹⁵ and was a member of the European Union as early as 1973¹⁶. In 2001 the social democratic government was replaced by the present centre-right wing coalition with a Liberal party leader.

The confederation of the German Empire was established in the late 19th century¹⁷ which developed into a federal parliamentary representative democratic republic. The nation was severely damaged during the First and Second World Wars, and then split as well into four foreign ruled administrative zones. The Soviet Union zone became the German Democratic Republic¹⁸, but was reunited with Germany in 1990. The nation became an early member of the Council of Europe and gained European Union membership¹⁹. In 2005 the social democrats lost their majority, thus a grand coalition was established between Christian- and the social democrats with the first ever woman appointed as Federal Chancellor²⁰.

The kingdom of England was united with Scotland in the 17th century and the United Kingdom of Great Britain was founded as a constitutional monarchy²¹. The nation was involved in the First as well as the Second World War and affected by human as well as physical casualties²². Just like Germany, Great Britain has been member and founder of the European cooperation established during the 20th century; Council of Europe, ECSC, EEC and EU²³. In the 2005 election the Labor Party won a re-election victory, but had seized power in 1997 by defeating the conservative Tories Party. In spite of the change in governmental policy, the liberal economic policies were re-developed further by the New Labor party²⁴.

Politic-historic relation	Finland	Norway	Sweden	Denmark	Germany	Great Britain
Historical relations	2	2	1	1	3	1
War affect	1	1	2	1	1	1
Present politics	2	2	4	4	3	1
European cooperation	2	3	2	1	1	1

Table 5222.1 Effects of dissimilarities in the society structures caused by political past of the two major funding groups; public and public-private was obvious only concerning historical relation; Finland-Norway and European cooperation; EU membership specified the public-private. On the individual level only Swedish built heritage was unaffected by the recent world wars.

To disclose if the present funding differences, public and public-private could be explained based on the political past perspective the data relations were coded by numbers (see Appendix 4). Distinctions between the national groups existed in *historical relations* and a majority of the nations in the public group were young. Also the *European cooperation* regarding the European Union membership revealed that private-public nations all had earlier membership in EU²⁵ than the public countries. However the effects of *war* and *present politics*²⁶ revealed no differences. Sweden was however an exception – the *war affect* – since Sweden has been spared from warfare for two centuries²⁷.

5.2.3 National distinctions of heritage authorities

5.2.3.1 Public direction

The Finnish²⁸ National Board of Antiquities, Museiverket (MV)²⁹, and the Ministry of Environments³⁰ are the distributors of public grants in Finland³¹. Private or public owners of heritage properties in Finland are directed to apply for public grants for conservation work. The MV distributes financial subsidy to owners with listed buildings³² and for exceeding conservation costs³³. Technical upgrading, rebuilding or adaptation measures are never qualified for public funding. The financial budget to the department has increased ever since 2002 when the new plan “Strategies of the cultural heritage”³⁴ was implemented. This new policy emphasises Finnish built cultural heritage values; “*The built cultural heritage in Finland represent 2/3 of our national capital*”() “*and it is irreplaceable*”³⁵. Recent reforms have been favourable for the Finnish heritage and applicants today can enhance their chances for funding by adjusting the conservation projects to fulfil specified conditions³⁶ since public subsidies have recently been supplemented by the surplus from state lottery funds³⁷. All in all the asset of public finance has become more stable, but sponsor activities are still scarce although tax-exemptions on capital gifts exist. During 2007 one third of the project applications could be granted subsidies; however all are projects to be completed within three years³⁸. Cultural heritage properties owned by minor associations are one of the highest financed programs³⁹ today but for this reason the properties are required to remain accessible to all citizens. The proceeds from a Finnish state cultural lottery⁴⁰ are also earmarked for finance “The one year grant” is available for any listed building but the conservation projects must guarantee completion within a year. The Ministry of Environment gives grants to the unlisted heritage projects of significance and high historical value. Promoting reductions of energy consumption has also become an important issue for building preservation projects and qualifies for funding. However this trend is not appreciated by all groups as the results might be counterproductive to good heritage ethics⁴¹. With inspiration from the British National Trust, *The Åbo Academy* has just recently been established; alas their efforts are not yet available for the Finnish heritage. “*The future looks bright for the built heritage in Finland but the development is slow*”⁴².

The Norwegian state⁴³ distributes subsidies to owners for conservation works on listed historical buildings. The Directorate for the Cultural Heritage, Riksantikvaren, (RA), is the major distributor of public grants⁴⁴ for private and public applicants to building conservation works⁴⁵. The allocation of subsidies can either be straight from RA to applicants or with the County administrative Boards⁴⁶ as mediators. For building conservations endowed by the RA, finance

is provided as payments for skilled craftsmanship, such as stucco conservations, to cover the most expensive preservation works and only listed buildings will be selected. Other circumstances which might qualify for public finance are for preventing an accelerating decay on built heritage, buildings at risk, to secure from demolition⁴⁷ or to sustain unique objects. Non-listed buildings are given grants only when considered to be of vital importance, thus contributing to an historical context⁴⁸ and all approved works have to be executed until completion⁴⁹. A large estate with unused wings is funded for the safekeeping of the whole ensemble, not only for those entities which are still of practical use⁵⁰. Building protection ventures which intend to improve standards of living, make modern installations or carry out other adaptation works on historic buildings for a new utilization, are never granted by the RA⁵¹. The recently established public Norwegian Culture Fond from 2002 has contributed to augmenting the total cultural budget for the Norwegian built heritage sector as a whole⁵². This fund distributes financial support to all kinds of unlisted buildings and the growing awareness in its path has encouraged the building heritage in general. At present no private funds or donations exist which could possibly match the public means⁵³ although tax-exemptions are available to some extent. In 2006 a survey program was initiated for investigating all cultural heritage buildings in Norway with the aim of establishing what the expected future demands might be for public funding. *“Ever since the Norwegian Culture Fond was established more public means are available for the heritage as a whole and that is a good development”*⁵⁴

The Swedish National Heritage Board, Riksantikvarieämbetet (RAÄ) is the main distributor of grants⁵⁵, for cultural buildings⁵⁶. Their allocated funding is established on an annual basis in the cultural budget⁵⁷ and primarily public subsidies are available for private⁵⁸ or public owners when it comes to building conservation. The RAÄ allocate finance to the 21 County administrative Boards (CAB) which are commissioned to approve or disapprove of the applications and convey the project subsidy. Conservation projects exceeding a specified sum of money will always be handled at central RAÄ level⁵⁹. Decisive for the RAÄ and CAB boards to approve of grants is that the funding concerns built heritage at risk, listed historic buildings, heritage representative for the county and whether or not the conservation measures will increase the accessibility⁶⁰. Collaboration ventures sharing project expenses by engaging the labour market (AMS) are also promoted. Lately the European Union funded projects within the EU frameworks have also been accessible, where the project costs could be covered up to 50% to alleviate international cooperation⁶¹. As the national church was separated from the State in 2000, one major reform has been established; the *Church Antiquarian Compensation Fund*⁶². Now the congregations themselves were made responsible for the Swedish sacred legacy and the fund gave the parishes opportu-

nity to apply for financial backup for maintenance, providing certain conditions were fulfilled⁶³. Since the cultural budget and thus the allocation to RAÄ were never predetermined, but annually changing, this complicated funding planning for the department. Especially so regarding how to decide what the regional offices (CAB) may obtain, which in turn settles the sums finally allocated to spend on local conservation projects. The cultural budget regulating the public funding for built heritage has lately been reduced. According to the calculations and statistics made by the RAÄ, their budget is therefore required to be doubled in order for the department to manage their assignment set up by the government. The critical situation seems to be worsening as RAÄ's obligations to fulfil constantly grow⁶⁴ though the allotment of public means, the 28:26 grants, remains unchanged. For instance the groups of listed buildings have increased by 700 sites over a nine year period (1995-2004) and may in 2010 be at least 2561 sites⁶⁵. For this reason the public funding available per monument will constantly be reduced. Estimation made by the RAÄ in 2004 shows that to manage actual funding demand for building protection, the level of grant has to be improved by 125%⁶⁶. In this case built heritage represents the majority of expenses⁶⁷ which is why the approved applications had lately to be reduced by 25%, since the annual cultural budget must also be spent on many new projects, within the cultural sector, other than on built cultural heritage⁶⁸. An alarming change due to a recent political decision⁶⁹ has agreed that the public department of RAÄ shall be split up in two. In the future, only the more service oriented divisions⁷⁰ of the heritage authority will remain intact in the capital of Stockholm and all other units shall instead resettle regionally on the island of Gotland. This total rearrangement of the department has unfortunately already had negative effects on the precarious financial situation for heritage funding and the authority of RAÄ⁷¹. This may even lead to a drop in skilled expertise among staff, since not all personnel can move to Gotland. *“The situation for RAÄ has been critical the last few years since the mission that our department has to fulfil constantly grows although the assignment of public means, the 28:26 grants, remains unchanged”⁷².*

5.2.3.2 Private-public direction

The Danish government distributes the finance allotment based on Danish finance law⁷³ to the Heritage Agency of Denmark, Kulturarvsstyrelsen (KA), and the sum has remained unchanged in the last few years. The department regularly receives also additional resources from private funds for all sorts of conservation projects⁷⁴. Only listed historic buildings qualify for subsidies and the other categories of non-listed ones have to apply from the technical departments in their local municipalities. Every application from a private proprietor is reviewed individually and approved for subsidy if KA finds the building unique, repre-

sentative or in other ways important for the Danish heritage. No programs or other directed selections are made and KA can financially support up to 50% of the project expenses⁷⁵. Out of the 200 applications that KA receives a year barely 25 can be approved⁷⁶. Danish trade and industry have sponsored culture heritage in the past, through various sorts of charitable foundations set up by companies and other private groups. Lately the number of private funds has grown considerably and this is why public funding has become less important and may at times only constitute 10% of conservations' total expenses⁷⁷. The authorities' control over Danish built cultural heritage has thus to some extent been circumscribed since public finance today has lost its monitoring capability⁷⁸. Public and private proprietors may instead apply directly for grants for conservation works on built heritage from these private foundations. Danish heritage authority nevertheless appreciates the well established funding cooperation with the NPO of Realdania and that private proprietors have the chance to apply from private funds⁷⁹ to preserve the national built heritage. To adjust and improve the financial situation for national heritage even further, the Danish government has appointed a commission at the Culture Department⁸⁰. *“When influential funds distribute grants for a project they also will inspire others to funding and put focus on a particular issue in conservation. What they do has an impact that the heritage can gain from”*⁸¹.

In Germany every individual state is responsible for its monument protection and their budget is distributed⁸² on a yearly basis through federal funding⁸². The state authority for culture and building heritage in Mecklenburg- West Pomerania⁸³ (LCDM-V) has received a share of funding which has remained unchanged during the last five years⁸⁴. LCDM-V 's main goal is to support the listed buildings and to make secure the original building structures. The most urgent buildings at risk are always to be considered first. Applications from private proprietors can obtain subsidies that cover 50% of the estimated building costs⁸⁵, but churches, or buildings owned by municipalities, can be covered by up to 80% of their expenses for preservation. To manage the growing gap between actual needs and available recourses, the authority applies regularly for grants from the EU funding programs and private foundations. Since all private foundations like the Deutsche Stiftung Denkmalshutz (DSD) may only grant 50% of the conservation costs, their private finance initiative will always activate state or federal funding. The reunion of Germany after 1989 brought a new era of funding initiatives called for by the vast neglect of the built cultural heritage in the new states. However lately, built heritage sector has been struck by setbacks due to the national recession⁸⁶. LCDM-V has an excellent funding collaboration with DSD though they have only lately been able to allocate a modest funding to this region⁸⁷. Other local palace funds exist in the district but they rarely have considerable sums to spare. *“No matter how much money LCDM-V 's distribute*

*on conservation works the effects will be worthless if the proprietors relinquish to take their responsibility for the regular maintenance work needed*⁸⁸.

In Great Britain⁸⁹, the Non-Department Public Body, English Heritage (EH) is responsible for the protection of built heritage and it was established in 1983⁹⁰. The Department for Culture, Media and Sport sponsor EH on a yearly basis⁹¹, but as a semi-privatized department they need furthermore to count on proceeds from their own estates, private funding and membership fees. In Great Britain the government transformed the fiscal policy and introduced new tax relief as well in 2000⁹² which reformed public bodies like EH. All were to various degrees privatized in order to stimulate private actors and industry to culture sponsoring. For this reason the surplus from HLF⁹³ for instance, together with other private endowments and funds, complement the incomes for the EH activities. English Heritage distributes public means but many private actors also contribute with funding on a regular basis. A number of trustees with own estates act as role models for preserving, managing and for the marketing of built legacy either for tourism, the general public or for schools. New trustee foundations are still set up which in the same way acquire, rebuild, adapt and market historical monuments for profits which are then reinvested in building stock, to cover the regular maintenance demands.

All applications that EH procure from building owners are judged according to the three levelled grading scale; Grade I, Grade II star and Grade II. The third category, Grade II, in this case hardly ever qualify for grants⁹⁴. Buildings at risk are the first to be granted and then according to the grading, but regular inspections of the “waiting list” might modify this order⁹⁵. More groups outside EH today have gained influence over building conservation in Britain and the decisions are often delegated to the local offices⁹⁶. Helm, *Historical environment and local management*, is one example of how EH actively works to improve commitment among local authorities for built legacy⁹⁷. English Heritage works in different ways to promote and market the historic environments through broadcasting⁹⁸ or for fundraising. Some critics believe that EH no longer spend the money where required i.e. for culture buildings and too much on different campaigns⁹⁹ while others think this is necessary for EH if it is to be recognized by society¹⁰⁰. “We must value historical environment not just because it is old but for what it offers, today and in the future”¹⁰¹. The funding available for private owners is not as generous today as in the early 2000’s, thus more private funding initiatives are required¹⁰². For church buildings the grants are still more generous though recent setbacks have occurred¹⁰³. “British people have another way of contributing to culture and heritage. There are lots of volunteer organisations devoted to charity in all forms and this has maybe something to do with the fact that taxes are lower in the UK, than they are in Sweden”¹⁰⁴.

Historic authority effects	Finland	Norway	Sweden	Denmark	Germany	Great Britain
Finance solidity	2	2	3	1	1	1
Funding claims others	2	2	2	1	1	1
Financial reforms	1	1	2	1	1	1

Table 5232.1 The possible effects of differences in work strategies among heritage authorities in the two funding groups only was discerned by the reimbursement demands of the public-private group. Once more however Sweden diverged in comparison to the other nations regarding finance solidity and reforms.

5.2.3.3 Summarizing the origin of public funding

To disclose likely unique work strategies among heritage authority departments, out of the two funding groups, the data relations again were coded. In table 5232.1 the only obvious divergence between the national groups was observable on *Funding claims others*. It revealed that only private- public nations required reimbursement of the funding from others; either by %- challenges, as practised in Dk and G, or as in the UK via public promotions. Concerning *finance* and *financial reforms* congruence existed; yet again Sweden was the exception since here both a fiscal solidity and finance inducing reforms are lacking¹⁰⁵.

The comparative analysis for disclosing if the origin of public funding – whether into public or private-public direction structures, – is influenced either by strategic decisions of the temporary politicians in office or by the work approach of the steady heritage authorities, indicated that it was politics which had the most impact. The political past showed for instance that countries in the public group; Finland, Norway and Sweden, were involved later in the common economical alliance of the European Union, as compared to their counterparts. Additionally the dominance of young nations in the public group¹⁰⁶ could imply that they have ties to Sweden still, which may have affected their funding policy. The sole impact from the authorities was found among the private- public ones; Denmark, Germany and Britain, with the reimbursement demands. The fact that private funding is here encouraged via the tax concessions, or the indirect funding, also has to be considered since funding claims are here viable as private support is induced, but that once again owes more to previous policy decisions.

The conditions for Swedish built cultural heritage finance revealed instability and an absence of funding motivating reforms. This is most likely caused by past political decisions, as the Swedish built heritage has not been threatened by foreign troops for centuries. The recent public church reform however revealed a positioning by the authority of giving priority to a public funding of detailed church inventories, as is conditioned for granting church maintenance to the parishes. This approach has been favoured, instead of encouraging the preserva-

tion built heritage as a whole by finance, which is said to be the effect when set up for the non-listed buildings, as practiced in Norway and Finland. The partition of church from state in Sweden was presumably making it more urgent for the heritage authority to instigate the church fund, as their influence over the sacred monuments was diminishing. A continuous finance deficit for Swedish built heritage can nevertheless develop into a much greater risk.

5.3 Methods

The public funding forms available for built culture are few in number but have immense importance since they reveal the attitude or benchmark policy on built legacy nationally¹⁰⁷. The three main forms of public funding for built heritage are ; direct funding (DF), indirect funding (IF) and replacement funding (RF). The direct form provides finance subsequent or parallel to, the project completion as money and the indirect funding is the opportunity to subtract a specified amount from the income tax. The replacement funding subsidises conservation projects by other forms of backing than cash. In the following outline a fourth form will also be discussed, which today is of regular use in the US; the credit funding. The investment form is practiced in many nations already for new constructions or like venture capital, but is barely in use for heritage funding. The public funding forms obtainable are exclusive methods, thus managed by either the politicians or the heritage authorities.

5.3.1 Direct funding; application approvals and public funds

The two major systems of the direct public funding are application approvals and public funds¹⁰⁸. The fund structure is often less dependent on changes in finance situation nationally, since the capital has once been earmarked for a specified funding distribution, for example unlisted cultural buildings. The finance available for application approvals on the other hand depends on the annual cultural budgets, which hence might fluctuate.

Application approvals are under the heritage authority expert's agency and endorsed according to the funding criteria defined in the legal protection act, involving the *legal value* (LV), as discussed in chapter 3. The highest priority have heritage at risk and listed buildings in all nations. One of the major predicaments with this approval form is that to produce the detailed application formulas required by the heritage authority, will involve inevitable initial costs for the applicant every time. The more an authority relies on political decisions of the

annual cultural budget, as in nations of public funding direction, the less accurate information they can offer applicants regarding their chances of receiving grants. Rejected applications are also hard to re-use a second time after a rejection, as the technical condition of the built heritage becomes inaccurate due to the continuous weathering of building materials. In the same way the cost for examining applications grows per work hour when public finances are low, since the selection then needs to be even more accurate when less of these are approved¹⁰⁹. If external finance was available, this would enhance the chances for applicants to receive grants elsewhere and thus reduce the time spent on the approval selections. The authority is responsible for selecting projects for funding, but in nations with private-public finance direction, the authorities' position and influence over heritage funding is stronger since they are taking part in the teamwork with private financiers.

Improvement made in Scandinavian public funds for build cultural heritage is rather recent and might reflect a new funding policy era. The Finnish Ministry of Education distributes for example public finance through funds to the culture sector, without a particular focus on built heritage. However, the state lottery funds have recently been made available, as previously described, in order to secure unlisted built legacy. Moreover, the Norwegian Ministry of the Environment recently established The Norwegian Culture Fond¹¹⁰ with public means, to secure the supply of finance for conservation works on unlisted buildings. During the five year period of its existence more than 400 heritage project have been granted on average 1/3 of their expenses¹¹¹. On an international level the Nordic World Heritage Foundation (NWHF) receives public subsidies from the Norwegian Government¹¹². The foundation collaborates with UNESCO on different projects around the world, as recently in South Asia, but primarily by distributing funding¹¹³. The NWHF is also coordinator for all Nordic countries on UNESCO's environmental issues¹¹⁴ and the UN cooperation projects are considered urgent, though some investments will unfortunately not be used for their initial purposes¹¹⁵. No Norwegian private fund can today match the public subsidies, although some minor tax exemptions exists¹¹⁶.

The Swedish Church Antiquarian Replacement Fund; Kyrkoantikvarisk ersättning (KE), from 2000 was set up as the national Church was separated from the State. The separation made each community financially responsible for their sacred legacy, which often includes early medieval constructions. Yet, every parish applying from the fund will only receive grants when a so-called maintenance plan; *Vårdplan*, is set up for the church entailing all data on its past and present conditions¹¹⁷. This pre-qualification demand involves additional expenses as well, which will be challenging especially for communities with many ancient churches¹¹⁸. The resources in the fund have increased continuously, but alas so have the

expenses of the budget originally allocated for all listed building¹¹⁹. On a global level the Minister of Culture is responsible for the Swedish UNESCO cooperation worldwide but none of these funds are available for the protection of the built cultural heritage¹²⁰.

Public funds in the private-public funding nations seem to be less frequent. Danish public funds for the national heritage have not been possible to register but the Danish UNESCO committee receives funding through public means¹²¹. The German Federal Cultural Foundation, Kulturstiftung des Bundes (KdB) was established in 2002 by the German Federal Government. Through the Federal Government Commissioner for Culture and Media, the Federal Government allocates a fixed budget each year. The foundation has developed programs that are relevant to the German society such as the heritage programme KUR¹²² for the preservation of Germany's movable heritage. Finally, British public means for built heritage earmarked as fund do not seem to exist, other than the Heritage lottery fund, which is based on private means¹²³.

5.3.2 Indirect funding; tax exemption, ROT and commercial property tax

Tax concessions are public subsidies since they constitute a public income loss, which is regulated by national policy and thus possible to launch only by the state. However, these represent most likely the most efficient tools for inducing financial activity among consumers, donors and investors. To authorize donors to deduct capital contributions straight from their income or profits is the one most practiced by indirect public heritage funding. Some nations make a distinction between private donor and companies, as is the case in Finland. Others have set up financial limits or defined a *gift* as a specified sum, as outlined in the chart, (see table 532.1). Tax concessions directed to companies are referred to as commercial sponsorship. The nature of tax concession as a funding incentive is effective since it ensures investment revenues for all without implying any deeper commitment, which both private financier and state may gain from.

The ROT-deduction can be described as a Swedish version of a temporary tax exempt program where delayed tax concessions can be approved for certain completed building measures. The ROT's normative limitation can be complicated to utilize and this requires that the additional control costs generated at the authority need to be covered as well. The public tool to reduce or increase sales tax, or VAT, on building materials can regulate incentives for the purchase of specific goods and is generally applied nationally¹²⁴.

Tax-concessions	Donating			Receiving		
	Country	Tax-exempt	Capital gift	Beneficiary	Criterion	Fiscal limits
Private person	Denmark	YES	100%, see limit	Non Profit Organization	> 500 Dkr	Max. 14 000 Dkr
	Finland	NO	none	NPO / Charity org.	none	none
	France	YES	66% and 20%	Fundation Patremonie	none	none
	Germany	YES	20%	NPO / Charity org.	none	none
	Great Britain	YES	28%	NPO / Charity org.	none	none
	Lithuania	YES	1% + 1%	NGO / Church	none	none
	Norway	YES	100%, see limit	NPO / Charity org.	> 500 Nkr	Max. 12 000 Nkr
	Poland	YES	10%	NPO / Charity org.		
	Sweden	NO	none	none	none	none
	The USA	YES	50%	NPO / Charity org.	none	none
	Company	Denmark	YES	15% / 10 years	NPO	> 500 Dkr
Finland		YES	28%	NPO / Charity org.	>850 euro	max. 200 000 euro
France		YES	60% / 5% turnover	Fundation Patremonie	none	none
Germany		YES	1milj. e/10 y. 0,4 to	NPO / Charity org.	none	none
Great Britain		YES	28%	NPO / Charity org.	none	none
Lithuania		YES	1% + 1%	NGO / Church	none	none
Norway		YES	100%, see limit	NPO / Charity org.	> 500 Nkr	Max. 12 000 Nkr
Poland		?	?	?	?	?
Sweden		NO	none	none	none	none
The USA		YES	50%	NPO / Charity org.	none	none

Table 532.1 An overview of the tax-exemption situation in Europe and in the U.S. (Sources are individual, see text).

5.3.2.1 Tax exemption in nations of public and public-private directions

When Finnish private individuals donate capital gifts to organisations (charity or others), or private persons, no exemptions can be made on the donors income prior to tax¹²⁵. The recipient is however released from taxation on the additional income¹²⁶. However, donations such as capital gifts to organisations, associations or persons, just recently entitled Finnish companies to subtract 28% of a donated sum from their proceeds, before taxation. Conditions for sponsoring to be valid are that the sum exceeds 850 EUR, which is the Finnish definition of a “gift” and the highest amount that is possible to exempt from income is 200 000 EUR. This corresponds to a capital donation of approximately 714 000 EUR¹²⁷.

The Norwegian taxation reform involves both private individuals and companies. The general rule for tax exemptions for organisation or private persons is that all donors are entitled to reductions on income for capital gifts¹²⁸. The criteria are that the beneficiary organisations receiving funds are non-profitable, voluntary or Norwegian and promote either humanitarian-, environmental- or culture requirements. This also includes the funding for preserving built cultural heritage; *Byggningsvaern*. A capital gift can be deducted from the income one to one, so that 500 NOK entitles the benefactor to 500 NOK exemptions before tax. This amount is the minimum sum to be defined as a gift and it may not ex-

ceed 12 000 NOK¹²⁹. Endowments for scientific purposes have other rules and enable a tax exemption of 10% on the donor's income¹³⁰.

The recent Swedish national tax reform today enables a recipient, or heir of a capital gift, to be exempted from taxation for the supplementary income¹³¹. The benefactors, even though private individuals or companies, are however not entitled to income reduction although the capital gift has already once been taxed¹³². Gifts from companies to the employees also have harsh constraints, in order to avoid them being considered as bribes¹³³. Sponsorship is a much discussed subject due to vague wordings for example regarding when to entitle a company to make tax exemptions for a capital gift, the so called sponsoring. This is possible only when there is an indisputable output gain for the company clarified in a sponsorship agreement. Yet this aspect is always complicated to measure and predict, but some NGOs like the World Wide Fund for Nature (WWF) have taken measures for situations like these¹³⁴.

Danish law¹³⁵ on tax exemptions for capital gifts entitles a private person to donate up to 14 000 DKK deductible from the donors income¹³⁶. The recipient has to be a non-profitable association. A donor, that is company or private person, who commits himself to at least a ten year payment, can obtain a higher tax reduction which automatically entitles the benefactor to a 15% financial deduction on the income before tax¹³⁷.

German endowments¹³⁸ or capital gifts to charitable or non-commercial organizations, such as the Deutsche Stiftung Denkmalschutz, may exempt the benefactors by up to 20% from their income before taxation. Alternative tax reduction of 0.4 % of the year's total turnover is also achievable for enterprises. Bequests up to 200 EUR do not need to be presented in the accounts. Gifts from companies that cannot fulfil the requirement of the special expenses one year may add them to the following year's taxable income. Endowments up to 1 million EUR can be tax exempted from the income over a ten year period, but only taxed ones. Donations are always exempt from tax for the recipient.

British *Gift Aid declaration* to a charity involves that the value of the donation will increase for UK tax payers by 28%¹³⁹. A rate relief could be obtained by higher taxpayers from the "Inland Revenue" which signifies that a gift of 1000 GBP can increase by over 500 GBP for the beneficiary¹⁴⁰. Since 2004 one Gift Aid declaration can apply to all past and future bequests. When a person donates money to a charitable trust, such as the National Trust, the Landmark Trust or to a museum¹⁴¹ in the UK, no charges on inheritance tax are made and this is why donation is used according to the first intention which means that taxes on income are re-used for the common good in society and directed by the national policy

5.3.2.2 Tax-exemption in other nations; Lithuania, Poland, France and the U.S.

In Lithuania bequests are tax exempted when donated to organisations and NGO's established for equivalent purposes¹⁴². One of the more innovative tax incentives developed originally in Hungary 1996 is the so-called "1% Law" which allows private individuals to give 1% of their tax liability to an NGO and 1% to a church¹⁴³. In 2001 similar tax exemption models were ratified in Lithuania, Slovakia and in Poland for foundations or associations that promote and favour activities that are beneficial for the public and include museums, cultural institutions and protection of the built heritage. Bequests are also tax exempted in Lithuania when donated to organisations and NGO's established for equivalent purposes¹⁴⁴. Polish benefactors, such as private individuals, may deduct fiscal gifts up to 10% of the income before taxation, since the 1990's¹⁴⁵. All French bequests made to the Fondation du Patrimoine are tax deductible up to 66%, but they depend on the donor status¹⁴⁶.

The U.S.'s tax exempt model for donations to charity was launched in 1978¹⁴⁷. All money donations from private individuals and companies to non-profitable organisations are tax-exempt up to 50% from the income¹⁴⁸. This has made the non-profit sector expand considerably over the last 50 years. The bequests primarily are donated to church, humanitarian organizations and education institutions in the US. The culture sector receives 6% of funds contributed to charity, and of highest priority for private donations, are built heritage projects that involve building in the main street of historical city centres in community preservation projects, but unfortunately less so in historical residential areas¹⁴⁹.

5.3.2.3 ROT deduction

The Swedish tax exemption; the ROT deduction, is a collaborative funding form and initiated originally as necessary policy measures in times of unemployment, where the heritage sector could be included. These tax concessions are viable for already completed building measures. The first Swedish ROT program¹⁵⁰ was launched in 1983 to stimulate building adaptations and energy-saving measures were approved, but without interfering or jeopardizing with the cultural values in built heritage¹⁵¹. The financial stimulation was called for because of the financial recession, with growing unemployment rates in the building sector at the time and was applied on a large scale nationally. Due to the new regulations defining apartment "modernization" the interventions grew in size¹⁵² and the precautions for historical values unfortunately came to be less considered. Original interior carpentry was often demolished and the genuine wooden windows were always replaced by new energy efficient standard ones.

The Swedish tax concession model has been re-established in 2008 for building maintenance work on built heritage, but this time in attempt to gain state control over the black labour market in the building sector¹⁵³, but it might also increase the up-keep costs. The model generates also additional costs for the heritage authority when inspecting the building measures, but increases the expenses for the building companies as well, who are made responsible for the unpaid time and extra hours put in by for example middlemen, liaising costumers and authorities.

5.3.2.4 Commercial property tax Credits

In order to make the cost of building protection compatible with the cost of building demolition or new construction, the federal government in the U.S. established tax credits. The wholesale loss of industrial and commercial building stock made by the federal government established these tax credits. The investor could here take a business-tax credit for all the whole invested sums and the provisions gained later contributed to further investments¹⁵⁴ in dilapidated commercial buildings stock. In some states even building materials are tax exempted from sales tax (VAT). Buildings owned by non-profitable organisations could for instance be exempted from property tax and this is a way a “non-profit” will have an advantage over the commercial and private investors¹⁵⁵. Tax exemption and tax benefits on all levels will always give support to local preservation groups¹⁵⁶.

5.3.3 The replacement funding; manpower and volunteer work

In times of recessions, when the financial assets are low in monetary terms, the human capital or manpower tends to become rediscovered. To combine an inevitable upcoming growing public expense, such as unemployment expenditures, the manpower model has frequently been applied to building conservation. In this case the politicians and heritage authorities need to collaborate.

During times of financial decline in Sweden subsidies to the built heritage sector usually have grown, to compensate for unemployment within the building sector. The increase has also provided extra financial support, such as manual labour or theoretical education in the field, thus initiating conservation works. This manpower is primarily represented by craftsmen, or construction workers of new production, who temporarily carry out building conservation work in theory¹⁵⁷ as well as in practice. These additional funding contributions are usually available for museums and public owned monuments¹⁵⁸. The Halland model was for instance one successful project that combined unemployment with building protection measures. The program initiated over 90 regional building conserva-

tions projects and the action provided one third of the unemployed workers with steady jobs¹⁵⁹. The model was later re-applied on a national scale in other programs, such as the “Tradition and building production”¹⁶⁰.

Similar to the Halland Model, temporary jobs in building conservation ventures were successfully set up during the 1990’s, after the merge of the split German Republic. The new German states at the time were experiencing a social upheaval and large groups became unemployed as jobs were lost, since most of the regional industrial production of former DDR was shut down. This replacement funding of manpower proved nevertheless also to be an efficient solution for re-establishing appreciation and respect for the built cultural legacy, which had diminished after the 50 years of a condescending ideological policy¹⁶¹.

Moreover, to fulfil the Wilson Challenge, the World Monument Fund accepted for the first time in 2002 replacement funding from the local authorities, to match the foundation’s support, during the protection works on the Maitreya Temples in Basgo Gompa, India. Here the manual labour was transferred into pecuniary resources and a form thereby was established for converting work hours to money¹⁶². In other words experience shows that not only financial solutions can be reached through the human resource model when it comes to building conservation. The replacement funding can also provide an opportunity for strengthening commitment of the local community for the regional built heritage. The positive side effects might even improve if new groups in society, other than the construction sector and employment groups could be reached, such as young people.

5.3.4 The credit funding; the Bond issue

To motivate private investments in building enterprises or the industry, among the early industrialists during the 19th century, business enterprises were marketed for instance as joint-stock companies¹⁶³. This joint venture of funding is continuously applied in new construction projects for instance for the new extension of the local university or for city centre redevelopments in Malmö, Sweden¹⁶⁴. In both cases the ownership and the investments made from the financiers had little to do with the properties’ future use.

As described in chapter 1 the use of bonds as investment models was implemented for hospital renovations in the US as early as in the 1980’s (Kluger 1984)¹⁶⁵. The issuing of bonds has successfully been applied also to enhance building heritage funding and provided a redundant, but historically significant city block on Manhattan with new life; the South Street seaport. The bond issue model here was primarily used for reconstruction works in municipal museums and enabled the seaport area of Downtown Manhattan, New York to be turned

into one of the largest conservation projects of its time and managed as a public private partnership. The South Street seaport incorporated 11 local museums¹⁶⁶. This investment form is possible for building conservations that require a considerable capital investment, but where the immediate pecuniary return can be postponed. The bonds always need to be assigned for a specified project and can either be inscribed by a local community or the state. The process begins by informing the general public about the project plans and what investments are required. Attracted investors then will purchase the bonds, which are secure since they are always guaranteed by the state. The bonds mature over a fixed time and the investment is set aside for the renovation project on low interest loan basis. The maturity of the bond decides the payback time and investors retrieve the repayment of their private lending at a time where the properties have become profitable.

Public funding methods	Finland	Norway	Sweden	Denmark	Germany	Great Britain	The US
Direct funding	12	12	12	1	12	1	
Indirect funding	3	3		3	3	3	34
Replacement funding	?	?	56	?	6	6	
Financial credit							7

Table 534.1 The table presents an overview of the public funding forms available for built cultural heritage in the countries. Financial credit form has also been added to the table though this is primarily practiced for heritage funding in the U.S. Since data is lacking concerning replacement funding, no national tendency can be found. (1) Application approval, (2) Public Fund, (3) Tax, (4) Commercial tax, (5) ROT, (6) Manpower and (7) Bond.

5.3.5 Division of consent of funding methods as control of finance

Public funding is the result of an agreement between the governing politicians and the civil servants at the National Heritage Boards. Among the funding forms obtainable are, as already mentioned, the direct funding (DF), the indirect funding (IF), the replacement funding (RF) and the credit funding (CF). These on the other hand involve different methods in practice which can either be of the consent of one single party, or require their collaborative performance. At first glance the different commitments of politicians and authorities reveal an even allocation (see table 535.1).

<u>Political consent</u>	<u>Collaboration</u>	<u>Authority consent</u>
IF; tax (CF);bond	DF; public funds ROT RF; Manpower	DR; applications

Table 535.1 The finance structures described are either subordinated to the politicians, the authorities or representing collaboration consent, thus ordered accordingly.

The expert status of the authority on built heritage issues, explains for what reason the application approval is relying on their consent. The politicians then again are responsible for any finance transaction which concerns tax concessions and this includes all other forms of time limited investments of credit funding, since they are dependant on political decisions. The finance methods that remain therefore are carried out in collaboration and involve the Public foundations, ROT-deduction and Manpower. However, when it comes to whom of the two parties that actually has the modifiable control over the individual public funding forms, the two parties no longer proved to be evenly influential when examining the collaborative methods used, (see table 535.2).

The ROT method for instance involves political standpoints having been taken at government level as regards taxes and manpower, measures which are also ideologically based agreements aimed at combating unemployment. This indicates that the authorities' control of public funding is limited to direct funding, by the approvals of applications and to some extent on the launching of public funds. Politicians in other words regulate the indirect-, replacement- as well as the credit funding. Furthermore, the allocation of finance in the cultural budget will also depend on political decisions and this is why direct funding also concerns politics.

<u>Political consent</u>	<u>Collaboration</u>	<u>Authority consent</u>
Indirect funding Replacement funding Credit funding	(Direct funding)	Direct funding

Table 535.2 The four finance structures described are either subordinated to one of the two active parties consent or a result of their collaboration. The direct funding categories can be application approval and public funds.

The national overview of the funding methods applied (table 534.1) shows the dominance of direct funding through application approvals. Sweden alone is not using tax exemption as a funding instrument to induce private support which would increase heritage funding and instead here it is replaced by the policy regu-

latory ROT method. The vital distinction between the forms is that only when the indirect funding is established as tax concessions, will it offer the authorities a more prominent position in heritage funding matters and influence based on their collaboration with private financiers.

The full extent of how replacement funding is in use has not been possible due to lack of data and the potential in credit funding is apparently only applied for heritage funding in the U.S.

OMAS; Public financiers of the built cultural heritage					
Financier	Origin	Methods	VP	Accelerators	Sustainability
Politicians	layman temporary strong	IF RF CF			
Authorities	expert stable weak	DF			

Table 535.3 Political and authority control over funding methods according to the OMAS format, here (OM).

5.4 Accelerators

Economic behaviour, such as public heritage funding, is initiated since built legacy can signify values which are recognized by the financiers through their unique set of accelerators. Politicians in government and the heritage authority are the two parties entrusted officially to spot and react to these values and for that reason their value preferences (V_p) will always influence the finance allocation, in the cultural budgets annually.

The amount of public funding reserved for cultural heritage is above all established by the economical conditions, but the incentive to promote and support ultimately follows the contemporary interpretation of worth since external actions, or time related circumstances make it fluctuate. In practice the shifting value judgements on historic properties will swing between the two extremes; from valuable assets for further investments, to heavy burdens conveying only expenses. In spite of the threats in the past, historic buildings still do exist and this confirms that external actions can continuously re-activate the accelerators of man. The renewed perception then attained will bring value increase, which provides financial activity.

Different origin or roles of politicians and heritage authority experts, like their commitments in the four funding forms, indicate an individuality of value prefer-

ences as well. In order to explain their separate inducements for heritage funding, first of all their particular value preferences have to be specified, based on the H_3 UNS concept. Founded on the value preferences, the accelerators which regenerate these selected values are also known which will operate whenever stimulated by planned or unplanned actions. All positive reinforcement of the value units, which might be of congruence for both parties, will for these reasons have a positive effect on their collaboration, since they link the two parties together.

5.4.1 Politicians; financial-, political- and obligation accelerators

The fact that politicians control the indirect-, replacement- and the credit funding forms implies that their rational value preferences (VP) for built heritage cover the four value units of; H_3 , U, N and S. The historic quantity value, H_3 , in this case represents the criterion definition of historic buildings among laymen, which thus includes politicians as well. This value focus is essential for broadcasting attention in general, which is required to establish indirect and credit funding¹⁶⁷. The utility (U) and the nominal value (N) encourage all funding methods employed, of the indirect-, replacement- and the credit ones, since public investments are always bestowed for the common good. The fact that politicians prefer the H_3 , U, N value units in the built legacy signifies their dependence on *financial accelerators* (FA).

However, times of external threat make political landmarks objectify the national identity and for this reason symbol value (S) must also be included in the politicians' value preference. This ideologically governed worth is rediscovered by the politician when the *political accelerators* (PA) become stimulated. Additionally, all groups working in the public body are evidently guided by the static and time-bound legal value (LV)¹⁶⁸ set up in the official protection act, thus contrary to the inclusive and changing H_3 UNS concept. This legal act declares that public finance is to be assigned for a selected part of the heritage, since it is based on the exclusive value criteria. The legal value is focused by the politicians in office every time as the *obligation accelerator* (OA) is motivated. This value increase only refers to the duty bound improvements of the legal framework as such, not a value increase of the built cultural heritage.

Financial accelerators (FA) assist one to recognise built cultural heritage for its financial qualities or values, when stimulated by *actions* of actual or expected *finance growth*. Alleviations in use restrictions of the historic built legacy could for example provide adaptation opportunities for new utilizations. This would most likely bring income by utility (U) and nominal value (N) growth, but only on condition that the historic quantity value (H_3) is guaranteed, thus limiting the exterior changes. In the same way actions such as tax-exempt inducement;

indirect funding, have been successfully applied in the reunited Germany since in 1980, in Britain with the semi- privatization of English Heritage in 1990 and in Denmark in 2000.

The acquisition of funding (template)
 $A+VP = V_A$

Acquiring funding from Politicians via financial accelerators ($A+VP = V_A$)

$FA+ H_3UN = V_A$.

A= FA, financial accelerators of value initiate funding by actions of actual/expected finance growth

VP= Value preference of politicians; rational H_3, U, N

V_A = Value activating to funding; indirect-, replacement, credit funding

The mechanism of funding

Action -----Accelerator ----- ($VP= V_A$)

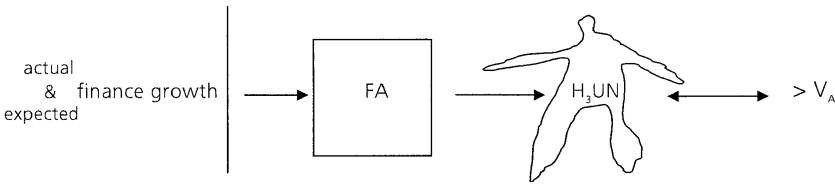

Table 541.1 The mechanism of public heritage funding of politicians, for the acquisition enhancement of new finance, requires actions of actual (a) and expected (e) finance growth, such as media, adaptations, tax concessions.

OMAS; Public financiers of the built cultural heritage					
Financier	Origin	Methods	VP	Accelerators	Sustainability
Politicians	layman temporary strong	JF RF CF	H_3UN	Financial (FA)	

Table 541.2 Politicians according to the OMAS format, here (OMA)

Political accelerator (PA) can increase, or decrease, recognition of built cultural heritage by ideologically stimulating actions and so inducting the symbol value (S). This accelerator will always convey new interpretations to past societies and the built heritage then become the three dimensional objectified codes. The ideological symbol value judgements for this reason are unreliable. Funding based on political accelerators can just as well favour extremism of protective measures or give good arguments for demolition by intentional value degeneration¹⁶⁹.

Actions of the political accelerator, such as ideological attitudes of nationalism, socialism or communism, might cause chain reactions. For instance the investments made for a systematic remodelling of Lutheran churches into basketball halls in Lithuania in the 1950's or the nationalistic style restoration in the 19th century financing the creation of never before seen exciting reconstructions¹⁷⁰. To trigger the political accelerator to increase heritage funding is for this reason unfeasible since the outcomes will always be unpredictable.

Acquiring funding from Politicians via Political accelerators ($A+VP = V_A$)

$$PA + S = +/- V_A$$

A= PA, political accelerators of value, initiate no funding by actions of ideology

VP= Value preference of politicians; S

V_A = Value activating no funding since unpredictable; +/- V_A

The mechanism of funding

Action -----Accelerator ----- ($VP = V_A$)

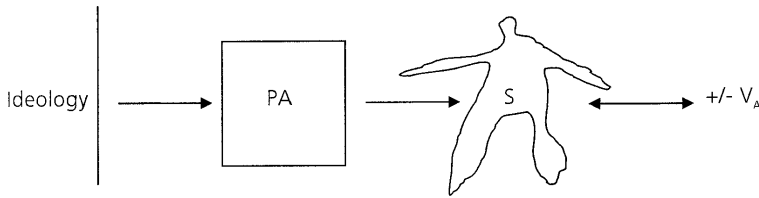

Table 541.3 The mechanism of public heritage funding of politicians can not establish an acquisition enhancement of new finance, since actions of ideology, makes the outcome for the built heritage, unpredictable.

The obligation accelerators (OA) for inducing the legal value (LV) refer to improvements of the artificially set forensic framework and they are stimulated by actions of duty. Theses accelerators do convey a funding stimulating value increase of the built cultural heritage as do the emotional and financial ones. Nevertheless, the national forensic framework of legal value reflects simply the value norm that once was generally accepted at the time that the law was passed. To increase legal protection could be to increase the number of listed buildings or introduce new restrictions of utilization. The effect will be in theory that more cultural heritage may be entitled to public grants. However this often implies that each property may retrieve less since public finance often remains unchanged. Listing as it is applied by the NLC in New York seems on the other hand to be like a quality branding¹⁷¹. Non-use restriction may secure original historical con-

struction, but only on the condition that capital for continuous maintenance can be available elsewhere.

Certifications of professionals by promoting only experts commissioned for monument protection may ensure the compatible measures in building conservation, thus avoiding future damages. Yet this approach can also contradict its initial intention of saving public funding and instead lead to cost increase¹⁷². To encourage the obligation accelerator involves a re-wording of the legal framework and will not affect the value to institute a funding increase.

Acquiring funding from Politicians via obligation accelerators ($A+VP=V_A$)
 $OA+LV= >$ normative framework (NF)

A= OA, obligation accelerators of value initiate no funding by actions of duty
 VP= Value preference of politicians, corresponds to legal value (LV)
 V_A = Value activating no funding only $>$ normative framework

The mechanism of funding
 Action -----Accelerator -----($VP= V_A$)

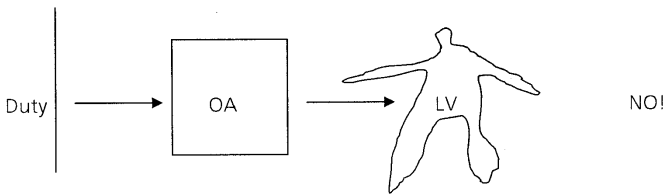

Table 541.4 The mechanism of public heritage funding of politicians can not establish an acquisition enhancement of new finance, since actions of duty only strengthen the normative framework of building protection.

The accelerators that induce politicians to perceive values in built heritage have been identified as; financial-, political and obligation accelerators. Only the financial one can be of use in increasing public funding. This implies that politicians wish to establish an economic climate nationally, which may promote *actions* to ease the political decisions for a potential heritage funding growth. They refer in this case to; media, building adaptations and tax concessions, since these stabilize the Historic quantity value (H_3), the Utility value (U) and the Nominal value (N) in built heritage.

5.4.2 The heritage authority; emotional and financial accelerators

Only the direct funding is under jurisdiction of the heritage authority experts by the application approvals and collaborative involvements in the public funds. For this reason the value preferences (VP) among the experts are the historical quality value (H_1) and historic knowledge value (H_2). These assessments are compatible with the legal framework, which is of guidance when prioritizing monuments for subsidies and these are induced by emotional accelerators.

International inventories of heritage sites, like the World Heritage List, often are initiated by the authority experts and disclose also the third value preference of the authority; historical quantity value (H_3). These international listings of significant cultural heritage have media potential to bring attention to significant cultural assets globally and even give rise to a local income increase, by the emerging cultural tourism in its path. This is why authority experts, just as politicians, are encouraged to recognize built cultural heritage for its fiscal quality values as well. As discussed above concerning the politicians, the heritage authority is also induced by the *obligation accelerators* with the resulting duty instigated actions, which also only reinsure the legal value (LV) set in the legal protection act.

Emotional accelerators (EA) increase the recognition of built cultural heritage by the actions of threat, information and access. To enhance emotional indicators providing historical value growth, $H_{1,2}$, this can be achieved either through international cooperation within ICOMOS or through international inventories like the Monument Watch since these transmit the indispensable information. To procure knowledge in any form is essential if one is to bring about mental and physical access and create a positive value increase and public funding. The action of threat should however never be intentionally used.

Financial accelerators (FA), increasing historical quantity value H_3 represent generally the most accepted value category since these generate positive contextual effects on built heritage surroundings¹⁷³. Even small financial encouragement for external refurbishments, may attract attention and encourage other financiers to invest. This effect can be reached in the Finish conservation programs directed to cultural properties owned by associations, just like the Norwegian Culture Fund set up for unlisted built cultural heritage but also in the French Foundation for the Native-country, approving tax concessions only for the rural built legacy visible from the main road¹⁷⁴.

Acquiring funding from heritage authorities via Emotional and Financial accelerators ($A+ VP= V_A$)

$$(EA/FA)+ H_{1-2-3} = V_A$$

A= EA, emotional accelerators of value initiate funding by actions of information and access
 FA, financial accelerators of value initiate funding by actions of actual/expected finance growth
 VP= Value preference; sentimental and rational H_{1-2-3}
 V_A = Value activating funding (direct funding)

The mechanism of funding
 Action -----Accelerator -----($VP= V_A$)

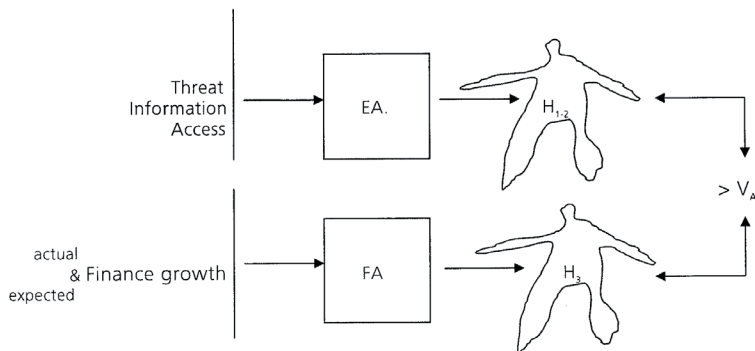

Table 542.1 The mechanism of public heritage funding of the heritage authorities for the acquisition enhancement of new finance, requires actions of information, access and actual (a) and expected (e) finance growth; media,

OMAS; Public financiers of the built cultural heritage					
Financier	Origin	Methods	VP	Accelerators	Sustainability
Politicians	layman temporary strong	IF RF CF	H_3 UNS	Financial (FA)	
Authorities	expert stable weak	DF	H_1, H_2, H_3	Emotional (EA) Financial (FA)	

Table 542.2 Politicians and authority experts according to the OMAS format, here (OMA).

The accelerators, which induce the heritage authority experts to value built heritage are the following; emotional- financial- and obligation accelerators. No value or finance increase is attained by encouraging the obligation accelerator; it only widens the legal framework, which on the contrary may increase the expenses. This implies that the heritage authorities wish to establish an economic climate nationally, which may promote *actions* to ease the authorities' decisions for a potential heritage funding growth. They refer in this case to; information, access

and media, since these stabilize the historical quality- (H_1), historic knowledge- (H_2) and historic quantity values (H_3) in built heritage.

5.4.3 Shared value and accelerator; H_3 and FA

A comparison of the politician and heritage authority reveals that their value preferences, according to the H_3 UN concept, are supplementary. The heritage experts represent the first H_{1-3} units and the politicians the last four, H_3 UN. For this reason heritage authorities have two accelerators; emotional and financial, while the politicians can only enhance value for historic buildings by the financial accelerator. Consequently the overlapping historic quantity value, H_3 , creates the platform where the two actor groups can communicate concerning public financial policy issues and future measures for built cultural heritage.

Value inducement of historic buildings;

Politicians; $FA + H_3UN = V_A$

Heritage authority experts; $(EA/FA) + H_1 \cdot H_2 \cdot H_3 = V_A$

Nations which early on introduced the indirect funding nationally¹⁷⁵ could take advantage of this fact which encouraged collaboration, as is applied in the private-public group. When the indirect funding, such as tax concessions, was initiated the heritage authorities could leave their obscure role set up by budget constraints and become an active partner in the dialogue, handling the external private financiers. Only the heritage authority has the unique capacity to bridge the value preference gap since they can relate even to the value accelerator of the politician's (FA) apart from their own (EA+FA). Still, when the heritage authorities gain more influence in cultural funding, this will also take its toll. A more humble attitude would then be required and sacrifices be made from preconceived beliefs suitable only for one limited group, on what will be paramount heritage protection, in favour of a flexible marked adapted approach, as for instance the one practiced by Brandenburger Schlösser, (see chapter 4).

In the public directed nations with direct- or replacement funding, equivalent fruitful collaborations forms will hardly take place. Here the authority will remain passive and constantly adjust to the changing financial conditions of the cultural budget. For this reason, preservations financed within the European Commission's Framework Programs offer new opportunities, since requiring always an active input of authority experts, however all EU funding is to be matched by 50% public subsidy.

OMAS; Public financiers of the built cultural heritage					
Financier	Origin	Methods	VP	Accelerators	Sustainability
Politicians	layman temporary strong	IF RF CF	H ₃ UNS	Financial (FA)	
Authorities	expert stable weak	DF	H ₁ , H ₂ , H ₃	Emotional (EA) Financial (FA)	

Table 543.1 Politicians and authority experts according to the OMAS format, here (MOA). Their unique set of value preferences is supplementary, though the authorities alone are induced both via emotional and financial accelerators to heritage funding. The private-public group of nations seems to have gained on this fact by assenting to indirect funding.

5.5 Sustainability

The publicly owned built heritage and monuments are cultural assets which outline the historical development in nations, but only on the condition that these are regularly maintained. Any kind of built holding in public possession will thus become an item of expenditure in a finance budget. Yet, built heritage can compensate these losses and provide incomes, either as rent from leaseholders or as promoters of cultural tourism, and additionally bring a contextual income growth to its vicinity. All measures that can create finance subsidies, for these irreplaceable built resources, should therefore be limitless, when considering its reimbursement capacity.

The national finance policy has at least three options for managing the protection of publicly owned built heritage; first of all to regulate the cultural budget according to the actual expenses, secondly to promote partnership by sharing the expenses with private groups by partial purchases or thirdly to develop economic incentives creating revenues to secure a private support. The finance deficit in the heritage sector is a fact and costs are increasing, which is why equilibrium based on merely public backing hardly is likely.

Funding collaborations have been utilized in the U.S heritage sector since the 1970's, since these adapted to the conditions of the market. Here the centralised public body was never developed, as in Europe, where it regulated the heritage strategy. However, the Netherlands were among the forerunners in Europe as regards finance partnership when re-establishing public museums into autonomous business units, while retaining public ownership. The new management responsibility has enabled great flexibility which proved to increase public service¹⁷⁶. The

Ronchey Law in Italy¹⁷⁷ initiated a reform of the state museum sector that lengthened opening hours and allowed private companies to operate services, such as ticketing, bookstores and restaurants¹⁷⁸. Finally, as discussed, indirect funding has proved to be most efficient for subsidizing private groups.

To determine sustainability of the national funding strategy in the countries, each property board's capacity for a dynamic finance planning of publicly owned built heritage, has been scrutinized. The approach in this thesis has been to disclose self-sufficiency of the property boards. That is, to what extent do they; *control the leasehold revenues, rely on state contribution* and if they *are involved in funding partnership with private groups*. In order to review the management of heritage funding in the two main groups, public and private-public, all countries are initially briefly discussed. Finally, the independence and funding capacity of Danish and Swedish National property boards is described in more detail in the two case studies, which are based on interviews.

5.5.1 Funding of public properties; Finland, Norway, Great Britain and Germany

The organization of the property board's heritage funding in the individual nation can either involve many or few departments of the public body, but the outcome has to fulfil the practical requirements for the subsidy to be efficient.

In Finland¹⁷⁹ the Senatfastigheter administrate the public owned cultural properties; the listed historic buildings and real estates. The revenue from the leaseholders is reinvested in the properties for maintenance work and corresponds to one third of the actual need¹⁸⁰. The exceeding two thirds of the costs Senatfastigheter has to cover with borrowed money¹⁸¹. The national property board in Norway is Statsbygg and their proceeds from their cultural- and real estates are transferred directly to the government. The Stadsbygg instead has an annual allotment to cover their expenses and they can apply for additional subsidies when required to cover exceeding costs¹⁸².

In Great Britain the property board is English Heritage, which incorporates the heritage authorities as well. All revenues from the lease holding are reinvested in the public estates. As a semi-public body English Heritage has developed new forms of cooperate solutions and is always occupied with attracting and encouraging new members, since EH depends on both external private as well as public finance. In the Germany state of Bundesland Mecklenburg-Vorpommern the public-owned listed building cannot provide any income since the few in public possession only generate expenses due to their ruinous state¹⁸³.

Dynamic public funding	Finland	Norway	Sweden	Denmark	Germany	Great Britain
Control revenues	x			x	no	x
Contribution state		x	x			
Partnership private groups				x	x	x

Table 551.1 The national overview intends to explain the property board's capacity for a dynamic finance planning, by revealing if they; control their own revenues, rely on state contribution or are involved in funding partnership with private groups. It is possible to distinguish between the two national groups.

5.5.2 The national property boards of Denmark and Sweden

The Danish National Property Board; Slots- og Ejendomsstyrelsen (SoE) administrate the two building categories; *office buildings* and *cultural buildings*¹⁸⁴. The office buildings cover their own upkeep expenses¹⁸⁵ with the rents from tenants and together they represent 1,2 million m². The cultural buildings are the listed historical monuments of 3000 m² and the costs for their maintenance fluctuate each year. The cultural budget set up for SoE is determined on an annual basis by the Danish government under the financial law¹⁸⁶ as part of the state budget and the sum has remained unchanged during the last five years¹⁸⁷. In addition to the fixed amount, extra funding is allocated additionally for special projects, such as for renovation works at the castle residence of the Danish crown prince and his family at Amalienborg completed in 2008¹⁸⁸. During the last couple of years much work has been performed at the royal castle but in general SoE do not favour any particular building categories, but they do assign the funding where it is needed. One important strategy is always to be aware when making investments so they can generate an increased income for the SoE. For cultural heritage buildings it is thus important that they will contribute to and stimulate tourism of all kinds¹⁸⁹. The Kronborg Castle in the Helsingör project is one of the most expensive conservation and reconstruction projects in Denmark at present¹⁹⁰. Thanks to grants from the Danish NPO; Realdania, 86% of the expenses could be covered and SoE will therefore be able to complete the venture, although the department is only capable of contributing 14% of the expenses¹⁹¹.

The Swedish National Property Board; Statens fastighetsverk (SFV) administrates the built cultural heritage properties nationally¹⁹². The Government decides the cultural budget annually¹⁹³ which for that reason fluctuates, according to the current policy, and the Department of Finance distributes the subsidies to The National property Board (SFV). The buildings which SFV administrates are of two categories both depending on their use and the budget directions; *the rentable-* and *the contribution* properties. The rentable represent 70 % of the

properties¹⁹⁴ which are the more recent office buildings and they always provide a surplus¹⁹⁵. Until recently SFV reinvested the proceeds from the rentable holding to cover up for the deficits made by these contribution buildings. This was the case until 2002 but over four years, 2003-2006, the government totally changed the funding policy. The SFV instead was provided with a requirement on rentable revenue payback of 6%¹⁹⁶ to the government. The effect was that public funding for the National Property Board was drastically cut and in 2003 they only received 180 million in return. Since the *contribution* buildings represent 30%¹⁹⁷ of the SFV's holdings with operative and maintenance costs of more than 280 million SEK¹⁹⁸ the financial cut of 100 million deficiencies made the SFV unable to fulfil their commitment; i.e. to protect the cultural legacy. The reason for this policy change in the budget conditions is unclear¹⁹⁹, but the precarious situation at SFV was continuously reported to the Government. Finally in 2007²⁰⁰ the budget again increased though the revenue requirements are still the same. The National property board now receives additional funding for their contribution buildings. For three years these new subsidies will be allocated and by 2007 they had already increased by 28%²⁰¹. Finally in 2009 they are expected to be 72% and SVF will have 310 million SEK to use on the contribution building and they have almost reached the level of the factual costs²⁰² for management and a reasonable maintenance of the Swedish cultural properties. What happens after the election in 2010 is uncertain and a new Government might reduce the budget back to the level of 180 million SEK again²⁰³.

The two case studies illustrate two opposing attitudes of how the national public properties are judged in the public bodies; as an investment or an expense. The Danish SoE reasons that the unavoidable expenses invested in the public-owned monuments must provide financial returns favourable for society as a whole. The strategic investments will most likely provide handsome profits for the common good. The revolving use of revenues, such as the rents for maintenance, may stimulate innovative solutions among personnel employed in this area²⁰⁴. The opposite Swedish approach where the civil servants lack influence over the tenant's rents, or financial means in general, hinders instead initiative taking as regards developing the income efficiently. When the built heritage's value is in consensus it might become further stimulated by the collaboration with private financiers, as was the case in Denmark²⁰⁵. The national public funding of the SVF is at governmental level not expected to provide any returns for the public body. The historic built heritage in Sweden seems thus less respected than it does in Denmark.

The Danish public funding is sustainable since the public properties are considered as unlimited investment projects for the public good and the practise of

indirect funding is essential. The Swedish public heritage funding is on the contrary unsustainable since it is insufficient and of a temporary nature.

OMAS; Public financiers of the built cultural heritage					
Financier	Origin	Methods	VP	Accelerators	Sustainability
Politicians	layman temporary strong	IF RF CF	H ₃ UNS	Financial (FA)	Influence via policy
Authorities	expert stable weak	DF	H ₁ , H ₂ , H ₃	Emotional (EA) Financial (FA)	Influence only by IF

Table 552.1 Politicians and authority experts according to the complete OMAS format. The table reveals the distinctions between the two parties involved in the public funding. It explains why an efficient teamwork between the parties most likely would enable the most efficient public funding. The common work platform will only be possible to achieve in the private-public national group. When the indirect funding is politically agreeable the authorities become active partners in the dialogue with private financiers. Only they have the capacity to bridge the value preference gap to the politicians.

5.5.3 Public or private-public directions refer to progression

The question of whether the funding types in the six countries; public or private-public, were due to political decisions or to the approach of heritage authorities indicated that political decisions most likely had been decisive. But considering that public funding depends on the quality, or efficiency, of their collaboration based on judging built heritage from supplementary viewpoints, according to the H₃UNS concept, this reduced the communication channels to one platform, H₃; the historic quantity value. In spite of the political dominance, the authorities for this reason actually have a unique position covering two value accelerator options; emotional and financial. This broader value enhancing and communicative capacity however is only available and activated when actions such as tax concessions are recognized nationally, that is; indirect funding.

This observation implies that initial differences in the national funding directions might not be due to permanent conditions in the countries but in fact represented different stages in a development which begun in the US in the 1970's. At this time tax concessions were launched giving the opportunity and incentives for private investments in the heritage sector, with the built legacy being marketed as objects for potential finance growth thus inducing the financial accelerators (FA). The development was encouraged by the simultaneously growing environmental movement initiate a general awareness rise, all of which therefore with the emotional accelerator (EA) now came to promote more potential worth

(H₁₋₃UN), a fact which intrigued new groups' interest in built cultural heritage, more than ever before.

The reunion of Germany as a nation gave rise in some way to a new feeling of maturity as regards the development of the German heritage consciousness, a feeling which had first budded in the 1980's, due to the foundation of the Deutsche Stiftung Denkmalschutz (DSD). This value growth brought the financial and emotional accelerator to life, since the neglected built cultural heritage became once again accessible after 50 years of seclusion. Apart from the national resurrection, the access to the east also renewed awareness among other neighbouring countries and stimulated the political accelerator so that also the symbol value was even more accentuated and encouraging H₁₋₃UNS.

In the 1990's the UK introduced a complete political change in the organization of the state department where public bodies were semi-privatized and tax concessions enabled new groups of cultural funding. Here the financial accelerator, using actions of value growth, placed the heritage authorities in a new and self-governing position so they were also able to manage the financial issues of public funding for building preservation, focusing also on the use and nominal values of the legacy and hence adding to the authorities emotionally accelerated historical values; H₁₋₃.

In 2000 the NPO funding concept was introduced in Denmark, with the NPO Realdania, providing enhanced funding opportunities for the built legacy and uniting scattered building conservation units, such as Byggningskultur Danmark. This also induced the already active company funding structure to increase their cultural funding commitment. This approach widened the authorities emotionally accelerated historical value H₁₋₃ via the use and nominal values with financial ones.

In the 21st century both Norway, with Norwegian Culture Fond and Finland by launching the Strategies of the cultural heritage, seem to be approaching this new private-public direction with the establishment of value broadening public funds and reallocation of lottery revenues. This most likely will enhance the position for built heritage in society so that it also will reach the local levels, thus young people, and bring about private funding.

The heritage funding situation in Sweden shows little of such innovative attempts to manage the built heritage²⁰⁶. Instead political decisions constantly diminish the budget and circumscribe the future prospects for the built cultural heritage to remain assets. Instability, cuts in cultural budgets or the newly begun reallocation of the heritage authority department RAÄ, again reducing the available funding means even further, might in turn also drain the public body of RAÄ of irreplaceable human capital; resulting in competence losses due to the regional displacement when heritage experts remain behind in Stockholm.

5.6 Summary

Public funding is organized by the politicians in government and the heritage authority experts at the National Heritage Boards. Politicians are transitory, in charge of the national decisions involving the public finance for the common good, but laymen in cultural heritage matters. The authorities with a grounded competence in the field of cultural heritage are the civil servants, upholding a steady position. The origin of the public and private-public structures in the countries was primarily due to earlier politicians decisions. Recent reforms in Norway and Finland indicated finance stabilization but deficit characterized the Swedish situation, caused by financial budget cuts.

Political decisions regulate and control three of the four available finance structures; the indirect-, replacement- as well as the credit funding which is why heritage authorities only are involved in the allocation of direct funding. However their influence will improve when indirect funding such as tax concessions are accepted as in the private-public countries for handling the additional private financiers. The Indirect funding also permits the bottom-up structure practiced in the U.S. and hence contrary to the established 19th century top-down form prevailing for instance in Sweden.

Politicians cherish built cultural heritage because of its rational significance with the value preferences (VP) of H_3 , U, N and S induced by financial accelerators (FA) by actions or notions of actual or expected finance growth. The authority experts respect built heritage both because of their sentiment and rational qualities, which is why their value preferences (VP) include H_1 , H_2 and H_3 encouraged by emotional accelerators (EA) with actions of information or access, but also by financial (FA). The overlapping historic quantity value (H_3) becomes the crucial platform where the two actors can communicate on public funding issues which strengthen the authority's position. This teamwork resource is better exploited in the private-public national group, by the acceptance of indirect funding and also by credit funding.

To profit from the two parties mutual acceptance of the heritage quality value H_3 of build cultural heritage, in collaborations, can never evolve in the public direction. Heritage funding is here limited to the direct or replacement funding, where the authority with the broader value enhancing ability remains inactive. Additionally, politicians as well as heritage authorities are affected by political and obligation accelerators enhancing the symbol as the legal value, but both have proved to be less efficient in securing built heritage when essential as in times of turmoil in society.

Public monuments are cultural assets generating maintenance costs but also income in the form of rents, by cultural tourism and as providers of contextual income growth. The difference between the public and public-private property boards' capacity to fund and encourage private financiers was determining the sustainability of the national funding strategies. The case study showed that the Danish public funding proved sustainable since legacy was regarded as an infinite investment for the public good. The funding cooperation with the NPO, established the authority experts as communicator from the emotional and financial accelerating perspectives. The Swedish national monument funding is unsustainable since it is insufficient and of a temporary nature. The cooperation between politicians and authorities failed to reach the common value platform of historic quantity value H_3 . Authorities for this reason could never exert their financial accelerators and so they focus on the emotionally accelerated values of historic qualitative and knowledge (H_{1-2}) in their attempts to promote funding, which could not be interpretable by the politicians, who processed the funding. The authority experts hence passively adjusted to the financially limited top-down funding decisions.

To conclude; public funding in the six countries forming the two directions; public or private-public directions, reveals the cooperative capacity between politicians and heritage authority. This can only fully evolve if political agreements will be reached which favour an enlargement of the public funding repertoire which includes indirect or even credit funding. The existing difference in the directions nationally is hardly due to permanent conditions but represented different stages in a development. This began in the US as early as in the 1970's, Germany in the 1980's, in the UK 1990, Denmark in 2000 and has reached Norway as well as Finland in 2009. This shift in finance strategy strengthens the position of the authorities but also involves principal sacrifices by limiting the demands on future non-utilization in favour of adaptation. These advances seem to promote the evolvment of efficient webs of private financiers capable of backing up the limited public subsidy, thus solving some of the future funding deficit. The heritage funding situation in Sweden shows less of the innovative attempts to manage the built heritage and instead political decisions constantly diminished the heritage budget.

Finally to test the hypothesis defining the characteristics of public funded projects from study 1 concerning; prolonged projects, building selective category and the focus on conserving; all assumptions once more can be verified. The length of time a project takes become extended as public finance is set on an annual basis, thus it is unstable. Additionally, this is due to the fact the civil servants seldom make any personal gain from completing work in record time as generally is the case otherwise among the private financiers. Only landmark buildings qualify for grants, which explain the selective building objective and then grants are primarily for skilled restoration work, never for technical upgrading or adaptation.

Notes chapter 5

1. See Appendix 1.
2. See Appendix 1.
3. Professionally they are often art historians, archaeologists, conservators or at times even architects.
4. After the *Finnish War*, Finland (2009, Web).
5. This was established by the Russia's Bolshevik government in 1917, *ibid* (2009, Web).
6. Council of Europe in 1989 and the European Union in 1995. Finland was the first and only Scandinavian nation to accept the Euro in 2002.
7. Since 1982 all Presidents of the Republic represented the Social Democratic Party, but the Centre Party was always influential in coalition governments over the years. Tarja Halonen was the first female president ever elected in 2000 and she still holds office, Finland (2009, Web).
8. Subsequent to the *Peace Treaty in Kiel*, Norway (2009, Web).
9. The Union was dissolved in 1905.
10. Norway is since 1960 a member of the European Free Trade Association and joined the European council in 1949, *ibid* (2009, Web).
11. The first woman to be elected Prime Minister in Norway was Gro Harlem Brundtland in 1981 for the Labour Party, *ibid* (2009, Web).
12. Sweden (2009, Web).
13. Member of the Council of Europe in 1949.
14. From 1917 with some exceptions during 70 years.
15. In 1949 Denmark became a member the Council of Europe.
16. The association was first the so called European Economic Community, Denmark (2009, Web).
17. Germany was unified in 1871.
18. The German Democratic Republic was established in 1949 in the Soviet controlled zone of Germany, East Germany (2009, Web).
19. Ever since 1950 and in 1958. Germany was one of the founders of the European Coal and Steel Community in 1951, which later became the European Economic Community; today's European Union, Germany (2009, Web).
20. Angela Merkel is the first woman Chancellor, the first native East German and the youngest ever.
21. This was in 1801. The Monarch is head of state and the Prime Minister of the government, Great Britain (2009, Web).
22. Britain was more severely damaged during the 1st World War, than during the second one.
23. Member of the Council of Europe since 1949, The European Coal and Steel Community 1951, the European Economic Community in 1959 which later changed name to the European Union, *ibid* (2009, Web).
24. Prime Minister Blair continued the economic politics within *New Labour* though these were initiated by the former Prime Minister, Margret Thatcher, representing the Tories. In the recent election 2010 the Conservative Party the majority and won the election with David Cameron as Prime Minister.
25. Though Denmark was the most recent member in 1973.
26. Nevertheless, Norway and Finland were governed by a Social democrats, or coalitions, which the Swedish politics was the most influenced by during the 20th century.
27. The centenary of 200 years of peace was celebrated in 2009 after the peace treaty, which was signed with Russia 1809 in the Finnish town of Fredrikshamn.
28. Facts about the Museiverket from the Finnish heritage authority; interview Maire Mattinen 2008.

29. Budget for heritage funding in 2007 was 1 million Euro, but additionally 1,3 millions Euro, came from associations, Mattinen (2008, interview).
30. The Ministry of Environments had a heritage budget on 2 million Euro in 2007, *ibid* (2008, interview).
31. The Ministry of Environment grants the unlisted buildings and Museiverket the legacy assigned as historical landmarks.
32. Buildings at risk have high priority, Mattinen (2008, interview).
33. Finish churches receive public subsidies from the assigned Church board, *ibid* (2008, interview).
34. "Byggnadsarvsstrategin" was settled by the Government in June 2001, Miljöministeriet (2008, Web).
35. Quotation from *Strategies of the cultural heritage* (Byggnadsarvsstrategin). The new strategies were already proposed during president Lipponen's government in 1998, but first realised 2001, *ibid* (2008, Web).
36. Either when conservation works are completed within a year, the building measures saving energy or for projects which will increase public access to built legacy, Mattinen (2008, interview).
37. The lottery fund solution was introduced in 2008, *Ibid* (2008, interview).
38. In 2007 69% of the applications were rejected for funding and the remaining 31% received a total of 866 934 Euro. The average grant lies between 5 000-20 000 Euro, *ibid* (2008, interview).
39. In 2008 it was 1,3 million Euro from the annual budget, *ibid* (2008, interview).
40. The lottery is originally set up for Culture in a general sense and had previously not been used for funding the built cultural heritage. This begun in 2008, *ibid* (2008, interview).
41. This hardly ever will be possible to combine if one is to ensure good building conservation ethics, *ibid* (2008, interview).
42. Quotation from Mattinen (2008, interview).
43. Facts on Riksantikvaren; the Norwegian heritage authority; interview with Francine Lampe 2008.
44. The so called *Tilskuddsmidler*, Lampe (2008, interview).
45. The local municipality is responsible for the maintenance and heritage funding of churches, *ibid* (2008, interview).
46. The so-called *Fylkeskommunerne*, *ibid* (2008, interview).
47. Provisional support constructions, *Ibid* (2008, interview).
48. Building sites which are revealing the living conditions for people of the past, *ibid* (2008, interview).
49. No matter building size, a roof repair has to cover maintenance costs for the whole roof, although the building is not fully in use, *Ibid* (2008, interview).
50. Abandoned buildings that have potential to be developed for a re-use can at times be funded by RA. General requirements from the authorities are that extensive conservation projects shall be planned by professional i. e. skilled architects and engineers and properly documented, *ibid* (2008, interview).
51. If these conditions are not fulfilled the subsidy could be postponed until everything is in order and inspected, *ibid* (2008, interview).
52. *Ibid* (2008, interview).
53. Pedersen, M. (2008, Interview).
54. Quotation from Lampe (2008, interview).
55. The 28:26 grant for concern of the Cultural environment, *Bidrag till Kulturmiljövård*, RAÄ (2005, p. 10).
56. Building conservation, historic buildings, culture landscape, archaeology and knowledge, *ibid* (2005, p. 10).

57. Policy decision of budget proposals are made in September and the budget document arrives in December, Gyllenhammar (2008, interview).
58. Private owners of historic buildings are of course required to contribute themselves every time, according to their ability.
59. Conservation costs which exceed 200 000 SEK, about 20 000 Euro, and this level has remained unchanged the last 10 years, Gyllenhammar (2008, interview).
60. The built heritage shall be available for all visitor groups, in spite of disability hindrances; elevators and ramps, RAÄ (2005, p. 11).
61. EU Framework Programs can at times provide half of the expenses, though these are not intended to cover the practical building costs, only the fees which are generated by the international work form, which aim to eliminate the national borders of Europe, Skogsberg, J. (2011, interview).
62. This is a translation from the Swedish; Kyrkoantikvarisk ersättning.
63. The so called Management plans, *Vårdplaner*, have to be established for every church, based on relevant historical documents available in archives and facts about the church buildings condition.
64. The increased number of listed buildings and new responsibility areas, which today include environmental issues as well, see RAÄ (2005, p. 13).
65. In 2011 the number of listed buildings, or historical landmark, is expected to be around 5000, *ibid* (2005, p. 16).
66. From 40 to 90 million SEK, RAÄ (2005, p. 16).
67. That is 68.5% from the 28:26 grant budgets, *ibid* (2005 p. 8).
68. Projects like for instance "The industrial heritage", "Agenda Culture Heritage", "Museums for the Workers Environment", cooperation projects and culture reservations, *ibid* (2005, p. 13f).
69. The Governmental decision was originally passed by the former government in office, which before 2006 was a coalition of the Social Democratic Party.
70. The library, the service administration and archive for example, Jönsson (2009, interview).
71. The stipulated cultural budget for 2009 on 250 million SEK was unfortunately cut by 15 million SEK (6%) to finance the Gotland relocation, *ibid* (2009, interview).
72. Quotation from Gyllenhammar (2008, interview).
73. The so called Finansloven, Morgen (2008, interview).
74. We receive 30 million DKK a year, quotation from *Ibid* (2008, interview).
75. The grants cover between 10-50% of the calculated expenses. Monuments at risk could at times be granted up to 100% of the costs, but that is rare, *ibid* (2008, interview).
76. That involves approximately 12.5% or 20-30 projects a year, *ibid* (2008, interview).
77. Interview Olsen, T. (2004, interview), he was the predecessor of Mogens Morgen.
78. Not all were convinced at first of the advantages of Realdanias funding dominance. For instance in 2004, the predecessor of Mogens Mogen; Torben Olsen, was less satisfied with Realdania's dominating position through funding and he feared that their influence would be far too strong. *"A private proprietor will not have to listen to or take advice from the heritage authority in the same way anymore since they can get money elsewhere"*, Olsen, T. 2004. From a different perspective; the heritage authority has lost their monitoring device, T. Olsen (2004, interview). Denmark do not have any percentage limitations balancing the amount of public/private funding in projects. In Germany this is regulated to 50% from private groups and 50% from the public sector.
79. Funds like Augustinus, Velux and others, see chapter 4.
80. In June 2008 the results from the Commission will come, Morgen (2008, interview).
81. *Ibid* (2008, interview).
82. The so called Landeshaushalt, Bednorz, M. (2008, interview). There are 16 states in Germany.
83. Landesamt für Cultur und Denkmalpflege Mecklenburg- Vorpommern.

84. We have received 10 million Euro annually, the last five years in a row in spite of the fact that the expenses have constantly risen, Quotation from Bednorz, (2008, interview).
85. The owners who have problems to provide the additional 50%, either by loans or private funding, and sometimes they do not even bother to apply for funding from us, *ibid* (2008, interview).
86. The financial setback in 2009 is not included in this study, although its effect has affected the public heritage funding in all nations studied.
87. *Die neuen Bundesländer* are the states which, from 1945 to 1989, used to belong to East Germany; DDR (Deutsche Democratised Republic).
88. Quotation from Bednorz, (2008, interview).
89. Interview with Anna Boxer in 2008. Boxer used to work at the Swedish heritage authority, RAÄ, in Stockholm. Ever since 2006, Boxer has been employed at English Heritage in the Manchester office.
90. The National Heritage Act was approved in 1983, see Cookson (2003).
91. The money that the government distributes hardly covers our administrative costs, Boxer (2008, interview).
92. Prime Minister M. Thatcher initiated privatization in UK in the 1980's, Boorsma (1998, p. 25).
93. The Heritage Lottery Fund handles enormous sums, which they allocate to different building conservation projects, Boxer (2008, interview).
94. Grade I represents 4% of all listed buildings, Grade II star 6% and Grade II 90%, *ibid* (2008, interview).
95. The staff here at EH are more involved in the practical conservation works at the building sites, than they are at RAÄ in Sweden. EH's offices is an active partner in projects and gives practical advice, *ibid* (2008, interview).
96. *Ibid* (2008, interview).
97. Initiatives to streetscape, improvements in housing projects and urban regeneration, HELM (2004).
98. In multicoloured brochures with straight-forward language, the English Heritage clarifies their messages. The EH's properties are opened for school children in program such as "Windows to the past" or information channel like "Heritage Counts".
99. Comments from a senior British employee at the English Heritage, Manchester office, Holden, J. (2008, interview).
100. *"I think EH is on the right track and that awareness has to be spread in different ways in order to reach all groups in society"*, quotation from Boxer (2008, interview).
101. Quotation from the Brochure "Changing London (2004, p. 2).
102. *"I have been told that in the first few years, after the changes 2000, there was more money available for the British built Heritage than today"*, quotations from Boxer (2008, interview).
103. *Ibid* (2008, interview).
104. Quotation from Boxer (2008, interview).
105. The Church Antiquarian Compensation Fund distribute grants for the preservation of only one building category; the churches, which is why these public resources can not offer the same positive response as the recent reforms in Norway and Finland have done, addressing all unlisted buildings.
106. Finland 1917 and Norway 1905.
107. Public policy toward culture is reflected in the applied economical interventions made such as regulations, tax concessions, public ownership or economical investments incentives , see Throsby (2004, p. 139).
108. Lottery funds could partially be considered as public funds in management, however, the capital recourses will always be private means since the purchaser of tickets are private groups, see chapter 6.

109. It could be the case that the heritage authority will split up the heritage funding available on many projects, thus, each of them will then receive less.
110. On 21st June 2002 the Norwegian Culture Fond (Norsk Kulturminnefond) was established by the Norwegian Parliament, Stortinget, with a capital asset on 1 billion NOK. Its interest rates are distributed through the Department of Environment (Miljøverndepartementet) to culture project all over Norway, The Norwegian Culture Fond (2008, Web).
111. Approximately 412 built heritage sites were granted with 27% of the expenses in average, which make 73 million NOK, *ibid* (2008, Webb).
112. This was 3. 5 million NKK in 2007, but of this sum at least 50% only covers the administration costs, Pedersen (2008, interview).
113. Nations in Africa, Asia and South America. Just recently NWHF completed the collaboration with UNESCO in South Asia where Norway allocated 12 million NOK during five years, *ibid* (2008, interview).
114. The climate change makes environmental issues imperative and Madagascar is urgent at present, *ibid* (2008, interview).
115. We try to get as much of the funding to the sites as possible and only to take 2-3 % for administration, but still UNESCO obtains 5% for their overhead costs every time, *ibid* (2008, interview).
116. There are no efficient private funding options in Norway to match what we are funding publicly today. Companies do not donate enough, even though tax exemptions exist, *ibid* (2008, interview).
117. The archived historical development of the church buildings, evaluation of value and provide the necessary facts concerning technical conditions.
118. The cost for Management plan report, Lund Bishopric in 2005 estimated to be about 1250 Euro, see note 63.
119. "About 400 million SEK was allocated to the Church Antiquarian Compensation Fund in 2008 and during 2009 this sum will increase to 460 million SEK", quotation from Gyllenhammar (2008, interview).
120. Grants are first of all available for students from LDC's; the Least developed countries, with a university degree. They can receive scholarships for further studies.
121. The Nordic Co-operation (Nordiska Ministerrådet), allocate funding through their Nordic Culture Fund (Nordisk Kulturfond) for Nordic culture in general.
122. Each year the German Government distributes 38 million Euro of the national budget to the Foundation on programs such as the; *Programm zur Konservierung und Restaurierung von mobilem Kulturgut*, (The preservation and Restoration of the movable culture).
123. See chapter 6.
124. Higher tax can be applied for monitoring a reduction of alcohol consumption and a low taxation in order to increase the consumption of book nationally.
125. Facts from interview with Kristi Seppälä, in 2008, at the Finnish Taxation Office in Helsinki.
126. Donations and gifts are tax exempted to some extent and also maintenance works as well when the owners send in their receipt to the heritage authorities Mattinen (2008, interview).
127. A capital gift or donation of 100 000 Euro entitles to a tax exemption of 28 000 Euro which is why the pecuniary worth of the gift as a whole will be 128 000 Euro, Seppälä (2008).
128. Facts from interview with Anne Gro Enger in 2008, at the Norwegian Taxation Office Oslo.
129. Enger (2008, interview).
130. A 500 000 NOK capital gift to science gives 50 000 NOK income reduction before tax, *ibid* (2008, interview).

131. Facts from interview with Birgit Karlsson at the Taxation Office in Jönköping. Until January 2007 private person or organization were obliged to pay 30% of the inheritance in tax, Karlsson (2008, interview).
132. Ibid (2008, interview). Sponsorship is a much discussed subject, see chapter 5.
133. Christmas present may not exceed a value of 400 SEK and bonds or stocks, in the same way can not exceed 10 000 SEK, ibid (2008, interview).
134. A Swedish company may offer the local sport association money for advertising a company's name during an important game that is broadcasted. However if the same sport association arranges a less significant match, but in the suburbs, tax exemptions might be denied, ibid (2008, interview). The agreement between the NGO; World Wide Fund for Nature, and companies gives the right to lease their well established WWF's Panda brand for company marketing purpose. In exchange WWF receives a sum of money agreed in the license contract, regardless of where the brand is exposed, Holmberg, J. (2008, interview).
135. Facts from an interview with Marianne.Madsen.-Andersen, in 2008, at the Taxation Office in Copenhagen.
136. At least 500 DKK is required if the sum is to be considered as a gift, Madsen.-Andersen (2008, interview).
137. Ibid (2008, interview).
138. Sonderausgaben, or the special expense, see Tax reduction Germany (2008, Web).
139. A contribution of 100 GBP will be worth 128 GBP for the charity, Tax exemption Great Britain (2008, Web).
140. If a higher rate taxpayer donates 1 000 GBP it will cost the giver 769 GBP and the total worth will be 1 282 GBP, ibid (2008, Web).
141. British museum, National Gallery, authorities, universities, government, museums and galleries.
142. Bulgaria, Latvia, Poland follow the same guidelines, see Moore (2003).
143. Ibid (2003).
144. Bulgaria, Latvia, Poland follow the same rule, Ibid (2003).
145. See Kowalski (1997, p. 72).
146. Individual income tax on up to 66% of the donation, maximum of 20% of a taxable income. Company has tax on up to 60% of the donation or maximum of 5 % of the annual turnover, Tax exempt France (2008, Web).
147. Facts from interview with Cynthia Garrett, in 2008, National Park Service, New York.
148. Today only 1% of the Americans donate part of their income, because only a few are able to. Nevertheless the bequests are expanding since tax payers can choose to what purpose and charity organization the bequest shall go to, see Burnham (1997, p. 85).
149. The challenge is to create incentives for property owner to invest in their own properties and not let them decline, ibid. (1997 85f).
150. ROT is an abbreviation for "Repair, rebuilding and building extension" program (Restaurering, ombyggnad och tillbyggnad).
151. To ensure the common good and that all will have an equal standard of living, no matter disability or age hindrance, Johansson (1997, p. 106).
152. The minimum size of apartments standards, totally altered the plan-drawing layouts by merging old apartments, see ibid (1997, p. 107).
153. Tax-emption up to 50% on the labour costs can be made when building measures are concluded, but the refunding is maximized to 50 000 SEK , Skatteverket (2009, Web).
154. This brings "billions of dollars", quotation from Burnham (1997, p. 86). This has successfully been practiced all over Manhattan, for example by companies like Two Tree Inc.).
155. See Ibid (1997, p. 85).

156. The provision that donors may deduct on gifts to charitable institutions, give the preservation groups new resources, which can be used for reinvests in other renovation projects, *ibid* (1997 p. 85f).
157. Lectures arranged by education institutions and universities, see Skarin Pålsson (1996, p. 11).
158. Monuments like the Visby city wall, see chapter 8.
159. The Halland Model project in 1993, about 36% (310/854) of the participants were provided with steady jobs, see Gustavsson (2009.p.90).
160. Tradition- och Byggproduktion was launched in 1996 by the Swedish National Heritage Board.
161. See Rossewitz and Jacobi Church in chapter 7.
162. In 2002 World Monuments Fund converted working hours to money, in order to settle the Wilson Challenge, when the local community contributed by establishing a human chain from the quarry to the building site to managed the transport, Weber, Mark (2008, interview), see chapter 4.
163. These funding and investment solutions were essential, for instance, for the railroad and sugar industry to develop in Sweden but also to establish leisure enterprises such as the AB Falsterbo Beach and Hotel in 1880's.
164. Swedish examples are for instance the Malmö University extension "Orkanen" with German investments or the commercial and residential area of "The Entry of Malmö", Entré Malmö, realised as well thanks to private means from investors.
165. See chapter 1.
166. See Burnham (1997, p. 86).
167. See p. 214 this chapter.
168. See chapter 3.
169. All form of value fluctuations can be a result of intentional or unintentional changes; so called *actions*. Intentional value degeneration was for instance when Rossewitz palace was left unlocked thus stripped of all its movable valuables or the demolition of former German medieval towns in western Poland (in 1950's) which were replaced by modern Polish concrete buildings. Moreover, the fact that 40% of the historical city centres in Swedish towns were knocked-down in the 1960's can also be due to planned value degeneration. These old buildings mirrored poverty and the unjust hierarchical society of the past and therefore they became unwanted for new political ideology. Modernism rejecting the historical past and this approach was embraced by the Social democratic policy. New modern concrete residential blocks were to replace the old architecture, see Asplund et al (1980, p.47ff).
170. The style purification movement, see chapter 1.
171. Listing is thus much restricted in Europe but in the City of New York, it is applied as a value enhancing device or quality branding, which will initiate private funding, see chapter 4.
172. The selected and "certified" professionals might sometimes "overlook" the option to reduce their consultant fees. On the contrary, they belong to the so called experts and have been assigned without an open purchase among colleagues which officially are just as qualified.
173. By vitalizing complete building blocks and providing employment when new businesses can be established.
174. See chapter 4.
175. In Germany this collaboration was established in 1985 with Deutsche Stiftung Denkmalschutz, in Great Britain since the 1990 with the semi-privatization of the heritage authority (English Heritage) and in Denmark it grew due to the establishment of the influential NPO (Realdania) in 2000.
176. See Throsby (2004, p. 146).

177. Approved 1993 and Ronchey, was the culture minister at the time 1992-1994, see chapter 1.
178. See Povoledo (2007).
179. Facts from interview in 2008 with Satu. Sampanin-Ahlgren at Senatfastigheter.
180. That makes 200 million Euro since the expense is approximately 300 millions per annum, Sampanin-Ahlgren (2008, interview).
181. This is about 100 million Euro, ibid (2008, interview).
182. “*It is never a problem we always receive the amount that we need*”, quotation from Morten Erlandsen in 2008, Stadsbygg.
183. Bednorz (2008, Interview).
184. Facts from interview in 2008 with Regin. Rönndal-Tenghammar, Slots- og Ejendomsstyrelsen.
185. In 2008 the maintenance costs were estimated to be around 85 million DKK a year, Rönndal-Tenghammar (2008, interview).
186. The *Folketinget* sets up the budget in the *Finansloven*, ibid (2008, interview).
187. The budget allocation has been 110 million DKK, ibid (2008, interview).
188. The costs for the conservation works at Christian VIII palace were approximately 100 million DKK, ibid (2008, interview).
189. ibid (2008, interview).
190. A reconstruction of a bastion, which was demolished in the 19th Century, ibid (2008, interview).
191. Realdania contributes with 150 million DKK and SoE provides the additional 25 millions. The total costs are estimated to be 175 million DKK, ibid (2008, interview).
192. Facts from interview in 2008 with Lena.Simonsson and Erika. Sjöberg at Statens Fastighetsverk.
193. In the so called Regleringsbrevet, Simonsson (2008, interview).
194. The rentable properties represent 123 2086 m², Sjöberg (2008, interview).
195. The operating and maintenance costs on the rentable buildings 2007 was 755 123 000, ibid (2008, interview).
196. This was counted in percentage points on the average of authority capital, Ibid (2008, interview).
197. The contribution properties represent 36 7362 m², ibid (2008, interview).
198. That is exactly 280 226 000 million SEK, ibid (2008, interview).
199. This might be due to the fact that the so called *Purpose properties*; the Royal Opera and National museum, for example, made complaints because they had difficulties themselves with reaching a surplus and were uninterested in having to pay for the *contribution* properties. Their rents have since then been adjusted and they no longer have rents adjusted to the conditions of the market, but only for the actual costs (*kostnadshyrer*), Ibid (2008, interview).
200. There was a new elected government in 2006; from a Social Democratic collisions to a liberal.
201. In 2008 this sum will be tripled to 61%, Simonsson (2008, interview).
202. “We need about 330 million SEK for the contribution buildings per annum”, quotation from ibid (2008, interview).
203. Ibid (2008, interview) and mejl 080313. The same government remained in office after the election, but the financial crisis has also affected Sweden.
204. The civil servants in the department lost the monitoring ability for allocating the tenant’s rents.
205. Realdania. “When influential funds distribute grants for a project they influence individuals and put focus on a particular issue in conservation. What they do has an impact that the heritage can gain from”, quotation from Morgen (2008, interview).

6. Acquiring alternative funding –Investment market, lottery funds, donators

6.1 Introduction

Financial investments from various private groups in more or less risky joint-stock companies are hardly a new phenomenon. They used to be most essential for development in the 19th century, not least for culture, when marketed for the new financial nobility; who were the early industrialists¹. International private investments are today applied more than ever before and accepted even by public bodies wishing to expand². When mutual interest exists public subsidies may join with the credits available on the financial market. Shared investments forms, or financial corporations, might at times be the only solution for realising new construction projects.

New investment structures and funding solutions are also called for if we are to sustain the persistent growing amount of built cultural heritage worldwide. In this chapter therefore three alternative financial sources have been scrutinized, based on the earlier presented OMAS format; the investment market, lottery funds and the financial donators. All finance forms described here are employed in today's society, but to a much limited extent for heritage funding. The problem is still one of initiating vital contacts between the investment market, or other private funding sources, and the heritage sector in order to establish right incentives, before commencement. An improved understanding of the three groups' funding inducements could have far more favourable outcomes for built cultural heritage than we see today. In other words; what kind of actions will stimulate accelerators of the alternative financiers' to perceive their own value preferences in the built heritage?

In spite of the alternative financiers' heterogeneous nature, their uniting pragmatic stance to investments in general, could in fact be a resourceful contrast to today's at times strongly politicized heritage funding, which has not always proved to be the most constructive in protecting the built cultural heritage.

6.2 Investment market

6.2.1 Origin; from early capitalism to market economy

Venice, the cradle of modern capitalism, was the most influential centre for trade in the 14th -15th centuries. The prosperity achieved, was due both to geographical location, governmental structure³ but also to the successful cooperation between public-owned shipping industries and private commerce. New trade routes to East India replaced Venice with the new northern and international centres for trade; Brügge in the Netherlands⁴ and Augsburg in Bavaria across the Alps⁵.

As a result of the agricultural enclosure movement in Great Britain, the prosperous wool industry was established⁶ providing affluence of labour as well as of capital. This finally enabled early British industrialization in the 18th century and with that the study of economics advanced. In “The Wealth of Nations” Adam Smith declared that in order to reach prosperity the mechanisms behind the production of goods have to be streamlined⁷. According to Smith to improve productivity, a split division of labour had to be implemented. Labourers were to be specialized in one task instead of controlling a whole production line. The free market economy was to be the coordinator and the competition, bringing investment growth, which should be the motivation and incentive for its success. The concern with making a good profit, guided by the competitive forces, would create results with people’s best in mind. This was Smith’s theory, but it was still essential that private cartels should be strictly prohibited⁸.

In a market economy, the prices for goods or services are the indicators of how the producers and consumers will act on the market. If the price level goes up the demand is higher than the supply, hence indicating that the production of the goods should increase. A low price is to be taken as a warning of overproduction and if the manufacture cost exceeds the sell price, then the production has to be stopped. Finally equilibrium will be reached when all parties are in balance, that is; producers, consumers and markets, but also supply and demand. Smith’s theory is still viable but the pure market economy rests on unrealistic assumptions, when it comes to discussing value⁹. Countries which early on had well organized trading traditions, on an international level, have marked orientated economies, such as Germany, Great Britain, Denmark and the U.S¹⁰. Political decisions which regulate the distribution of income or wealth in a nation and what steps to take for full employment, have established differentiated market economies. Norway, Finland and Sweden with more of a normative market are considered to be mixed economies.

In a planned economy finally, the rules of market are completely replaced by theoretical decisions made by politicians at the administrative level. One central

body is then collecting all necessary information to develop a long term production plan¹¹. History has shown that the practical implementation of the planned economy model was less resilient. Nevertheless the Soviet Union did develop an efficient production of high technology during the 20th century¹². One major problem with such planned economy management was the internal communication between entities. To receive and pass on information in the former Soviet system, was to negotiate through a static and hierarchical system, a system which obstructed itself, so it was unable to develop. Stifling the birth of any possible innovative ideas within the planned economy model, caused its industry in the long run to stagnate. The five year production plans overlooked peoples' needs and what they really craved, all of which led to shortages or the so-called "affluence of left shoes"¹³. Apathy together with the bonus systems in place for administrators and factory employees¹⁴ nourished a growing black market trade and parallel society structures¹⁵. In 1997 the black market economy was still very much a constant reality for the average person in Lithuania¹⁶.

OMAS; Alternative financiers of built heritage					
Financier	Origin	Method	VP	Accelerators	Sustainability
Finance market	13 th century				

Table 621.1 Finance market according to the OMAS format, here (O).

6.2.2 The working capital circulation on the investment market

Affluence in the pre-capitalistic societies was rare in history, but when achieved, affluence often manifested itself as investments in single projects; cathedral building, luxurious products or warfare¹⁷. This unplanned capital spending discloses the distinction between the early and late capitalistic systems. When the change occurred, it became instead a question of encouraging surplus to be re-invested back into production. In this way wealth was now made available for whole society and not glorifying, say, only a single emperor. This is as well the strong driving force in companies, according to Dillard¹⁸, never to settle for a high production of goods, thus continuously to improve the profits enabling reinvestments in the production. In this way new companies could be established and affluence be spread by more work opportunities.

As early as in the Middle Ages merchants begun to discuss whether profits could be used more effectively and the income-generating financial transactions became the answer. Since some merchants preferred to accumulate their wealth instead of reinvesting it, this progressed and finally the investment market materialised. The bank¹⁹ became the middleman for these transactions and this provid-

ed a circulation of assets such as interest loans for investors and deposits for the capitalists. This financial market still applies to the trade of credits, instruments of debt and company shares.

A recent definition of finance is “the subject that studies how individuals”... ”raise, allocate and use money and other assets over time for risky or non-risky ventures²⁰. The mission assigned to the financial sector²¹ is to invest funds from well-off investors efficiently; with a minimum risk for capital loss and maximum profitable return. Economy is connected to politics since financial issues of prosperity are fundamental questions in all societies. The ability to predict and find ways to calculate what the asset return of a certain investment will bring, is most essential for the science of economics. Successful theories which have been created moreover have been rewarded with the Noble prize. The theory entails the questions of how to develop concepts according to some basic conditions, which need to be fulfilled, before defining the problem to solve. Economy is no precise science where processes can be studied and repeated endlessly. For this reason theoretical models are developed as generalized forms, which simplify the description of reality where the basic data can be provided and tested in theory²². However, two fundamental propositions can be set for economics, say Peacock and Rizzo, ‘human beings’ behaviour patterns are consistent; and human nature is constant in time and space and every human choice involves cost, represented by the alternatives forgone²³.

Though today’s economy is global and the European Union has developed into an open market, yet diversity still exists. These are founded on old codes which have individualised the financial structures, when it comes to its logistics. Investors and recipients on the financial transaction scene can be dealing directly with each other. On the global financial market agents rarely have any contact and these affairs are thus solved through financial institutions or markets. These various parties assist their clients in making less risky, less costly and for the most part profitable transaction. Whether the middlemen are banks or market dealers depends on the tradition in each country and in what way deals of this kind are primarily closed. Scientific analyses on what the real efficiency is of the two most significant forms; bank based or market based economies -are constant matters of disagreement. Countries, where the market is more adapted and developed for transactions, are called market based economies, as applied for instance in the U.S., UK and Sweden. Japan and Germany are their contraries as bank based societies, when it comes to the praxis of closing financial deals, from payments to financial decisions. For an investor these differences are of huge importance, but for private consumption, this has little effect. In any nation we can buy and sell more or less the identical merchandise for the same price, since the two groups of countries have global and competitive economies²⁴.

Financial theories have been developed within science to come to terms with the predicaments in the global economy. The financial institutions, or markets, that assist the investors to make efficient transactions are, as mentioned, either market or bank based societies²⁵. In the 1990's research issues concerned the advantages of the two forms (Black, B. & Gilson, B. 1998). Some economists argued in favour of the stock-market-centred systems, which were described as more dynamic, equal and freer. The bank-centred capital market was, on the contrary malfunctioning since it was too rigid. Others (Levin, R. 2000) questioned whether the discussion was needed at all and suggested a focus on what the whole financial system can achieve together. Politicians should stop interfering in favour of either of the two. Their focus should instead be on property rights, improvements of the law text issuing court judgments in order to implement stronger laws -was the conclusion. The vast cross country comparison surveys in 2002 (Demirgüç-Kunt, A.&Levin, R. 2002) illustrated how the financial systems differ worldwide. The financial development had made stock-markets' intermediaries more active at higher income levels. Nations which were wealthier had a more active stock market than those of the bank financial system. Common law countries in general had a better protection for shareholders' rights and had also less corruption. Countries of the French civilian law tradition had on the other hand a more underdeveloped financial system.

Another group of researcher (Arestis, P. & Luintel, A:D. & Luintel, K.B, 2005) later re-tested the results from this latter study. This time the group was applying another survey method²⁶ which was regarded as more suitable to use for developing countries. This time they could prove that pooling of heterogenic countries was far too complicated and could give misleading results. The researchers were as yet convinced that financial structures matter for economic growth. Nevertheless, economy is no exact science and only tendencies can be observed.

Finally, when discussing the financial market, it is unavoidable not to comment on the global financial crisis which begun in 2008. The Deputy Chairman of the Financial Service Authority (FSA) in Great Britain, which under guidance of Lord Turner launched the *Turner Review 2009*²⁷; Forseeke, K. was therefore asked to comment on the background to the present situation. Here is a summary of Forseeke's reflections; the last two decades, with a shift of production of goods to Asia, meant an introduction of a new money flow from West to East. The deregulations of the financial market in the 1990's, gave the opportunity to develop new forms of return on investments.²⁸ Demand for return escalated, to enable and increase in liquidity. This predicament was solved by the creation of synthetic "credits" and new techniques were introduced of how to re-use a dollar more than once. To secure this non-existing capital, for this reason various structured products appeared on the financial scene and it all became a "Bubble

in making”.²⁹ Parallel to this development, the lending circuit in the U.S. banking system was introducing loans with low securities for family homes. This was possible because the banks found new ways of combining many diverse and unsecured loans into one single portfolio, the so called sub prime loans. The rating institutes accepted these risky portfolios with combinations of a variety of loans and they were in some circumstances given triple A ratings; the highest possible credit ranking. Politicians, banks and investors globally made profits on the flourishing capital markets on this non-existing fiscal coverage, until the collapse of the first credit institute came; Lehman Brothers. Then the house of cards fell with a chain reaction echoing on all financial markets world wide. The principles of loan-to-value and loan-to-income should be re-established, but how and when only the future, will tell³⁰.

6.3 Methods

6.3.1 The investment market; credit funding

Banks, insurance companies, investment management firms and exchanges are the most influential finance institutions on the capital market. The familiar banks, initially mediators of capital between entities for surplus or loss, today have concentrated their field of work since competing with other actors for customers³¹. To spread risks in business deals, the financial parties buy insurances and the insurance premium may allow a capital repayment in the case of loss of property, individuals or health. Bank assurances reduce the losses on capital transactions, but also insurance companies need to secure themselves with reinsurances. The investment management firms represent a wide spectrum of actors who buy and sell assets³² for an investor’s money, with the aim of making a good profit. Problems may occur when the return is leveraged with borrowed money by the investment firm. Other firms have specialized in collecting funds from the general public and reinvest them within a certain category of stocks³³. Exchanges, finally, represent far more than the familiar stock exchange but they all must provide a controlled marketplace where a quantity of goods or services can be traded³⁴. To comprehend the non-institutional financial market, the following eight methods of transfer means are sufficient to explain its essence; the depth market/ fixed income, depth market/credit, equity-, foreign exchange-, commodity-, forwards and future-, options- and real estate market, (see table 631.1).

Financial investment forms			
Credit funding	Character	Name	Potential funding for b. heritage
Depth- fixed income	Riske free money lent to state maturity 1 mth. 10 years+ interest rate	Bond	Money in conservation project interest % value up=safe
Depth - credit	Credit, money lent companies/banks Risk for non-payment= high interest rate	Corporate Bond	To risky for BH
Equity	Buy shares in companies, uncertain dividend= risky, no proof prosperity in C	Stock	Become share holder of culture heritage, safe= dividend up
Foreign exchange	Fluctuating foreign currency effect assets, huge market	Currency transaction	Risky and complicated In future better? Euro or Dollar.
Commodity market	Buying/selling & trade in most influential assets; Oil, nature gas, gold	Commodity	To risky for BH
Forwards and futures	Insurance for companies by lengthening spot price; aircraft fuel, weather...	Forwards Futures	Investm. historical urban fabric! guarantee future value growth
Option	Minimize investment risks, call & put options; buy spot price/ sell spot price	Call option Put option	Investment cultural heritage value change= dividend
Real estate	Commercial & residential buildings Investment high & low house prices	Futures	Modern buildings, value both up and down

Table 631.1 To comprehend the non-institutional financial market the following eight methods for transferring finance are sufficient to explain its essence; the depth market/ fixed income, depth market/credit, equity-, foreign exchange -, commodity -, forwards and future -, options – and real estate market.

The government *bond* is the most essential merchandise dealt with at the *depth market/ fixed income*. To buy a government bond indicates that risk-free money is lent to the state by an investor in exchange for an agreed interest rate. The maturity decides when this loan expires and this can vary from months to years³⁵. Equivalent to the way a government lends money at the capital market, private companies and banks can for the same reason issue corporate bonds. This *depth market/credit* needs to convince the investor or buyer of full repayment with interest since the non-payment situation, so called credit risk, may occur. For this reason the lending partner pays a much higher interest rate than for the government bonds. The deviation of interest rates is called the credit spread. In spite of the enhanced credit risks, these dealings represent the fastest growing market today. The stock, or the *equity market*, gives an investor an opportunity to be one out of many owners of a specified company. The dividend, or interest rate, that the investor regularly receives will always fluctuate since it depends on the success of the company and this is why the equity market is considered very risky³⁶.

If an individual buys a house abroad the person needs to consider the timing since the foreign currency price for these dealings is floating. The loss or gain will be rather limited for buyers in comparison to what might occur during currency transactions made at the *foreign exchange* markets and explains the size of the market. The *commodity market* represents the concrete equivalence to stock and bond markets³⁷. Gold and oil are in focus for these trades and the price of the latter,

controls the global business cycle. Our former, present and future societies have been, and will always be, affected by the oil recourses world wide. The intrinsic value in gold makes it change in an opposite direction to other commodity assets and this fact can help bridge fast changes on the commodity market. The price for a house represents the spot market price since the financial deal is closed immediately. However, for companies which are planning a larger production, all parameters that affect the costs would give the managing director sleepless nights, unless the fluctuations in the production expenditures could be secured. One way to solve this dilemma is to buy a “price insurance” at *the forward/future market*. Here the buyer pays the spot price for a future deliverance, which provides his company with risk reductions³⁸.

The *option market* is another example of how groups on the financial market try to minimize the investment risk. When purchasing a call option on a stock a buyer is ensured of the option, or the right, of buying to a fixed price, no matter what happens with the price of the stock. In the same way a *put option* gives the purchaser the right to sell to a pre-determined price³⁹. Real estate is distinguished by the trade of commercial and residential buildings. Falling and rising house prices have made investors interested in the *real estate markets* lately and the trade with “future contracts”⁴⁰. The funding form which the investment market allocates for investors will always be a credit funding.

OMAS; Alternative financiers of built heritage					
Financier	Origin	Method	VP	Accelerators	Sustainability
Finance market	13 th century	CF			

Table 631.2 Finance market according to the OMAS format, here (OM).

6.4 Accelerators

6.4.1 The investment market; financial accelerators

Dealers at the investment market have in general no pre-set relationship to built cultural heritage in particular. Their goal is instead set on good investment planning. As described, bankers early on understood their roles as money mediators between the capitalists and the production entities. No public body impinged on this initiative; on the contrary, this role grew from the situation at hand. The norms were set by the players and evolved into a dynamic financial market. Early trading capitals like Amsterdam could then flourish, though also be hit by set-

backs. Assigned by one group the bank dealers transferred a sum by investing or lending out the capital, to others for an expected profit.

By observing how the origin and methods of the investment market are organized, the value of built heritage in this group can most likely be disclosed and strengthened when promoting the rational value preferences (VP) of historic buildings, according to the H₃UNS concept, that is; H₃UN. The first; historic quantity value, H₃, represents the key definition of historic buildings among laymen and is essential for all media attention. The second, characterized by utility value (U), is what is enabling proceeds. The third is the nominal value (N) which refers to the financial investment conveying actual interest increase or expected economic worth. This unpredictable or risky circulation of assets stimulated by *actions* of actual or expected finance growth, shows that only the *financial accelerators* (FA) are creating a flow on the investment market. Acquiring funding from the investment market can be expressed as follows;

The acquisition of funding (template)

$$A+VP = V_A$$

Acquiring funding from Investment market via financial accelerators

$$(A+VP = V_A)$$

$$FA+ H_3UN = V_A$$

A= FA, Financial accelerators of value initiate funding by actions of actual/expected finance growth

VP= Value preference of investment market; rational H₃, U, N

V_A = Value activating funding; credit funding

The mechanism of funding;

$$\text{Action} \text{-----} \text{Accelerator} \text{-----} (VP=V_A)$$

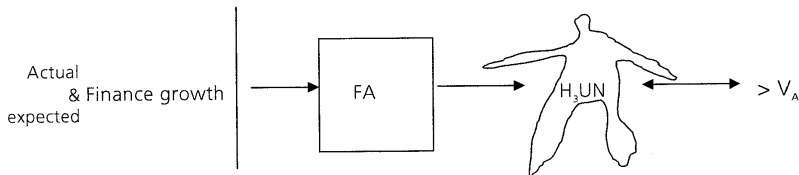

Figure 641.1 The mechanism of heritage funding of the investment market, for the acquisition enhancement of new finance, requires actions of actual (a) and expected (e) finance growth such as media, building adaptations and tax concessions.

OMAS; Alternative financiers of built heritage					
Financier	Origin	Method	VP	Accelerators	Sustainability
Finance market	13 th century	CF	H,UN	Financial (FA)	

Table 641.2 Finance market according to the OMAS format, here (OMA).

When the board members at the Financial Service Authority, as discussed, were setting up the *Turner Report* in 2009 they were fully aware of the impact which actions have on the financial accelerators for investment market. To strengthen the financial accelerators with *actions* of actual or expected finance growth, is consequently the last thing needed at present⁴¹ since the speed in constructed asset growth on the financial market, since the mid 1990's, has blinded even the responsible parties⁴² to abandon the "loan to value" principal. This is one of the major reasons for the financial global crisis in 2008 and based on this experience "a minimum of regulatory requirements"⁴³ were recommended in the Turner Report. Due to the markets' poor adaptation to the global production line, which since the mid 1990's had been allocated to China and Asia, before the finance crisis, now revenue of real capital was reduced everywhere else. Still capital could nonetheless be traded, since it was replaced with inconsistent synthetic credits⁴⁴.

Significant for all investment made, are their trigger effects on encouraging others financiers to act. The more esteemed the investor is, the higher the bequest will be respected among others. This also has been expressed within venture capital research and investments will most likely be an endorsement for the recipient and recognition, in this case even for built cultural heritage. This is why even small contributions must be esteemed, since they have the ability to inspire more.

The accelerator that may well induce the investment market to perceive values in built heritage has been identified as the financial, which will increase investments or new funding. This implies that an economic climate exists nationally, which may establish *actions* for the finance markets for a potential finance growth and they refer in this case to; media, building adaptations and tax concessions, since these stabilize the historic quantity value (H_3), the utility value (U) and the Nominal value (N) in built heritage.

6.5 Sustainability

Early financial investments first of all were available for companies since they were generating wealth to societies⁴⁵, but over time the focus of attention has come to include the most diverging undertakings. Built cultural heritage has re-

peatedly proved vital for nations over the centuries, both from functional as well as sentimental aspects, or else it would have been long gone. It represents a long term, environmental friendly⁴⁶ and energy saving investment with good future prospects, when marketed. Yet, regular maintenance requirements generate the sense of value decline, though this is not only applicable to built legacy, but to any weather exposed items. Important to point out is that value growth, or decline over time, only represents intellectual and passing value interpretation of built heritage, not actual physical changes of asset. Values are therefore assumed to be infinitely present in any legacy.

Investment forms already practiced in the U.S., such as the historic preservation easement, provides proprietors of built heritage with the opportunity to sell for example, facades of historic buildings through a non-profit, easement-holding organization such as NPOs⁴⁷, which establish the easement contract. According to this contract the new owner is committed to maintaining the façade for all time and in exchange is permitted tax exemption which is equivalent to the estimated market value of the building. This tax exempted income profit can be reinvested in other easements, where the preservation of façade will once more be guaranteed for eternity. Wholesale loss of industrial and commercial building providing business tax credits⁴⁸ is another efficient solution concerning ownerships, which stimulates a financial accelerator as action of finance growth; whether actual or expected. Split ownership already exists for residential buildings today with the residential associations, which is why multi-ownership of historical buildings seems possible⁴⁹.

Among the present investment forms applied on the market, a majority is unfit to use for cultural heritage investments, but the two forms which in this study have been found relevant are the bond and stocks combined with put options. In the 1980's bonds were successfully exploited for larger Downtown Manhattan conservation projects⁵⁰ and issued either at federal, state or local level. In connection with hospital renovations, bonds are regularly used, whilst options are for new constructions⁵¹. *Municipal bonds* may also provide new potential as an instrument for rising the extra funding needed, for specified ventures in local communities in the U.S.⁵². This low-risk form is also an ideal type for senior citizens' savings, as long term investments, who are not opposed to the long maturities. In return investors receive a regular tax exempted income; the fixed interest rate on their investment.

The question is if the heritage sector could possibly provide incentives enough for investors dealing with long or short termed financial investments, only by initiating the financial accelerators with actual or expected finance growth? Yes, most likely, if for example municipal bonds would be applied for instance to fund the conservation of a local church. This may turn out to be an excellent

combination – it becomes a means of attaining the financial support and raising the level of the commitment among locals and ensuring the future value stability. Moreover to invest in shares, which is a much riskier endeavour, for recycling industrial legacy for instance, could be another way, at least theoretically speaking. Especially by combining the purchase in a portfolio with put options, this would secure the risk of value loss since these are linked to the spot price. This implies that revenue gained is guaranteed when selling the shares since it will never be less than the actual cost, or price, at the time of the purchase⁵³. However this proposal would hardly be possible under real life conditions, but to establish shares in buy back programs might be. The investor could hence never lose more than he was initially investing.

Investment market most likely has potential to become even more important to future heritage funding, than it is today. Financing in built heritage also attracts attention to the area which in turn adds value growth as is similarly observed in connection with venture capital⁵⁴. Yet, capital growth is thus essential but at the same time the main predicament since tax exemption is a national policy concern and not uniform worldwide. Successful solutions in a neighbouring country might not provide the expected results elsewhere, but achieving a widened involvement in built heritage is a priceless gain. This is why some exceptions might be required if one is to solve today's funding deficit. New channels leading the investment market on to heritage funding would not only secure the prospects of built cultural heritage onward, as a part of the global circulation of finance, but would also increase awareness of its value.

OMAS; Alternative financiers of built heritage					
Financier	Origin	Method	VP	Accelerators	Sustainability
Finance market	13 th century	CF	H,UN	Financial (FA)	Self-sufficient

Table 65.1 Finance market according to the complete OMAS format.

6.6 Lottery funds

6.6.1 Origin

The tradition of financing public building constructions by lottery funds is known from written sources and the Great Wall of China was among the first mentioned⁵⁵. Even Augustus Caesar funded repair works in Rome by lotteries during the Roman Empire and in the 15th Century the Dutch city of Sluis used the sale of lottery tickets to aid the poor and reconstruct fortification works⁵⁶.

During Queen Elisabeth's reign in Great Britain's 16th century the lottery tickets had the character of a bond where the holder was rewarded with a prize. Specialised brokers cooperating with sales agents later received the right to deal in lottery tickets in Britain. Since quick profits could be made, misuse also occurred and lottery funds for this reason were prohibited until the 1930's⁵⁷. A great number of American universities are founded thanks to financial contribution gained by the sales of lottery tickets⁵⁸. Recently game venture forms have been flourishing and more than one hundred lotteries were established in Europe⁵⁹ during the 1990's with the Spanish National Lottery as role model. Regardless of whether the Lottery is in public or private ownership, or how the profits are divided, the source of funding by consumers of tickets will always be drawn out of private capital.

The non-department public body of for example the British Heritage Lottery Fund, which is the regulator of financial and policy direction is public⁶⁰, but this could also be a private company as with the corresponding Dutch lotteries. To use lottery proceeds for public good such as culture or building heritage is hardly a new invention, but it is a form which has been redeveloped during the 1990's. Below are some European examples where each has individualized methods due to unique benefactor groups and goals.

OMAS; Alternative financiers of built heritage					
Financier	Origin	Method	VP	Accelerators	Sustainability
Finance market	13 th century	CF	H ₂ UN	Financial (FA)	Self-sufficient
Lottery funds	300 b.c.				

Table 661.1 Lotteries according to the OMAS format, here (O).

6.6.2 Methods; direct funding

The lottery fund chronology presented covers both inactive and active lottery funds where the proceeds have been, or easily might become allocated as heritage funding. The lotteries are individually specialized which shows their ability to adapt for various fields of interests, since the consumer of the lottery tickets, and investors of the lottery funds, may still have diversified goals with the purchase. This is a fact the lottery funds are fully aware of and which they exploit in their marketing. Private lottery funds of today are often divided into *two parts*; a non-profit association which has the lottery authorization and a back-up management firm. The funding form which lotteries can offer by selling lottery tickets is *direct funding*.

Swedish Lottery fund for culture

From 1889 to 1939 the Swedish nationwide lottery; *Lotteriexpeditionen*, was a well established private association. Through their proceeds made on the so-called *Penninglotten*, adequate financial means could be accumulated at the time to create a majority of today's significant culture institution, not least in Stockholm. Their initial mission was to help save the City exhibition in Stockholm 1889 and Sweden's first Museum of History in Stockholm in 1934 was among the last once funded⁶¹. Lottery surplus during these five decades was also utilized for building conservation works over the entire country⁶². The lottery was nationalized in 1939 and new lottery games have been invented ever since where the proceeds, other than to the state budget, are allocated to sports and culture which today receive only just about 0,001%⁶³.

*Glücks Spirale*⁶⁴

In time for the Olympic Games in Munich 1972 the lottery *Glücks Spirale* was established in Germany and in 1974 proceeds from the lottery were collected in favour of the world championship in football. Since 1991 part of the proceeds from the television lottery *Glücks Spirale* were earmarked for monument protection in Germany⁶⁵, shortly after Germany was reunited with former Eastern Germany states. The number of beneficiaries is growing and the recent addition was a foundation for global nature⁶⁶. The lottery tickets are inexpensive but for an additional sum the purchaser can enhance his chances of winning a fortune by purchasing new shares in additional lottery games.

Heritage Lottery Fund (HLF)

HLF is part of the National Lottery Fund (NLF)⁶⁷ and a sub-organization of the National Heritage Memorial Fund (NHMF), established in the end of the 1970's for Britons who were killed in the Wars⁶⁸. The National Lottery was created in 1994⁶⁹ for the sake of allocating money to the five good "causes"⁷⁰ and one of them was cultural heritage. During the Blair administration HLF focused their activities to encourage companies to invest in HLF⁷¹. Out of every pound that NLF receives on lottery tickets almost 50% is distributed to built cultural heritage through HLF⁷². After ten years, in 2004, the fund had distributed more than 3 billion GBP to heritage projects in the UK. The average amount of funding each year has been around 300 GBP and not only for listed historic buildings, since HLF's definition of heritage is everything that has been inherited from the past⁷³. Since HLF is an active financier, innovative projects have also been developed over the years, for instance research has been granted which involves youth in heritage as well as other target initiatives⁷⁴. The main goal for HLF is to inspire

citizens to get involved and be committed to take a stance about the future for local built heritage, for its protection and accessibility.

Through HLF's development team, all applicants are assisted in order to submit applications for grants to conservation projects⁷⁵. The lottery's teams develop five year strategy plans for implementing new projects and always aspire to be updated with new projects in historical townscapes⁷⁶. Through television programmes such as "Restoration" personal involvement and interest has increased as viewers are able to vote on rescue projects for buildings at risk. The HLF supports television programs on archaeology as well and "Time team" has been able to improve the understanding of the sites by using computer graphics.

Novamedia; Bingo Lotto and Postcode lottery

Even if the first historical museum and conservation works on churches in Sweden could be financed thanks to private means from lotteries⁷⁷, the intention of the Bingo Lotto lottery funds was not culture oriented, when set up in Sweden in 1989. The lottery was immediately successful in collecting private resources through lottery tickets, since it was broadcast⁷⁸ on Swedish television and so in 2005 the Postcode lottery was introduced. Both lottery funds are of Dutch origin and produced by the private Novamedia concern. The concept or brand name of Bingo Lotto was later sold to the Swedish "People's movement"⁷⁹ by Novamedia in 2005. The same year as Postcode lottery started, a game distribution on the internet was also established in cooperation with a large publisher⁸⁰. The profits from the Bingo Lotto are allocated to non-profit organizations and preferably sport associations⁸¹. Their endowments reach over five million members⁸². Approximately 16 billion SEK have been distributed to Swedish organizations over the years and top prizes are awarded annually⁸³. What regulates the amount of funding which a "member" is entitled to, depends on the number of lottery tickets the association or sport's club has sold in return⁸⁴.

The Postcode lottery is a *two part* charity lottery with the purpose of contributing to "a better and greener world"⁸⁵ by the means of "commercial tools"⁸⁶. This market run charity lottery has been established in Sweden since September 2005 and they have contracts with nine non-profitable beneficiaries⁸⁷. The tenth recipient is their own Postcode foundation which distributes financial grants to private organisations that work in favour of mankind, nature or wildlife⁸⁸. From the rich turnover only 22.5% will be allocated to the beneficiaries on a yearly basis⁸⁹. One branch of the Novamedia concern in Holland donates at times their proceeds to culture⁹⁰.

OMAS; Alternative financiers of built heritage					
Financier	Origin	Method	VP	Accelerators	Sustainability
Finance market	13 th century	CF	H ₃ UN	Financial (FA)	Self-sufficient; B,S/P
Lottery funds	300 b.c.	DF			

Table 662.1 Lotteries according to the OMAS format, here (OM).

6.6.3 Accelerators; financial

The origin and methods of funding; to purchase an inexpensive lottery ticket requires neither profound knowledge, nor an emotional concern for its beneficiaries. The purchase itself does not even need to be a premeditated act, but rather a result of an instant desire to win a million. The fact that all groups might become the lucky ones seems to have been sufficient and explains the success of lottery tickets over the centuries. Nonetheless to secure the sale of lottery tickets, influential lottery funds encourage the vast majority in society to purchase by using engaging subjects⁹¹, as *actions*, and up to date beneficiaries such as charitable organisations. Heritage Lottery Fund is most likely the single lottery established where the proceeds are specifically allocated to the built cultural heritage, to begin with. Both Glücks Spirale and the Finnish equivalent⁹² have included building heritage funding in their mission. For this reason HLF is expecting more from the buyer. Through informative brochures the general public is informed about what their ticket purchase will bring⁹³.

The origin and methods of the lottery funds show that a growth in ticket sales could be managed for built heritage, once the rational value preferences (VP) according to the H₃UNS concept are promoted and they here refer to ; H₃N. Medial exposure of the beneficiaries is equivalent, which therefore corresponds to the historic quantity value (H₃), the shining exterior. The nominal value (N) motivates the investment, as it refers to the increased chance of winning a fortune. These value preferences are induced by *financial accelerators* (FA) and in turn stimulated by the action of actual or expected financial growth, through television or brochures on beneficiaries, from non- profit organisations to heritage at risk. The allocation of funding from lottery funds can be expressed as follows;

Acquiring funding from Lottery funds via financial accelerators ($A+VP=V_A$)

$$FA+ H_3N= V_A$$

A= FA, Financial accelerators of value initiate funding by actions of actual/ expected finance growth

VP= Value preference generated by the lottery funds; rational H₃, N

V_A = Value activating funding; direct funding

The mechanism of funding;
 Action -----Accelerator -----(VP= V_A)

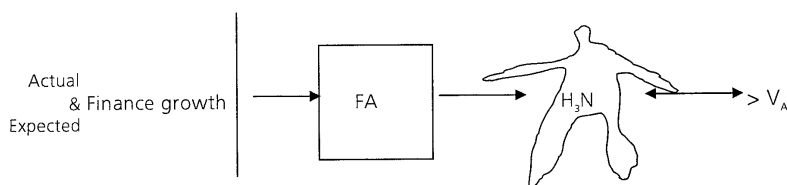

Figure 663.1 The mechanism of heritage funding of the lottery funds (i.e. the purchasers of tickets), for the acquisition enhancement of new finance, requires actions of actual (a) and expected (e) finance growth such as media and tax concessions.

OMAS; Alternative financiers of built heritage					
Financier	Origin	Method	VP	Accelerators	Sustainability
Finance market	13 th century	CF	H_2UN	Financial (FA)	Self-sufficient; B,S/P
Lottery funds	300 b.c.	DF	H_3N	Financial (FA)	

Table 663.2 Lottery funds according to the OMAS format, here (OMA).

To enhance profits or new heritage funding through lottery funds, two alternatives are possible; re-allocating the proceeds from existing lottery funds to built cultural heritage or establishing new lottery structures. When considering the impact of the beneficiaries such as the NGO's have for today's lottery⁹⁴ funds, this explains that the cultural heritage needs to market its importance for society as well. The accelerator that could induce lotteries and their purchasers to perceive value in built heritage, to increase funding, has been identified as; the financial one. This implies that an economic climate exists nationally, which could set up *actions*, such as media and tax concessions, for lotteries and their costumers for finance growth, since these stabilize the historic quantity value (H_3) and the Nominal value (N) in built heritage.

6.6.4 Sustainability

Lottery tradition has been very rewarding in the past and the proceeds most welcome for the beneficiaries. Since the lottery concept does not involve any commitments, neither from the buyer nor the supplier, the proceeds can be allocated to a great variety of activities or beneficiaries. State lotteries may for instance use their revenue for completely new purposes, from one year to the next. This was also practiced by the Finnish state lottery fund where since 2008 the proceeds have been instead allocated to "The one year grant"⁹⁵In spite of the lottery flex-

ibility the lottery funds will still, with the significant beneficiaries, have the most positive impact on ticket sales and the distribution of profits. The demand for active involvement might be modest, but good marketing of the beneficiaries is quite essential and only results pools in sports, like football, actually demand prior knowledge.

An open ticket where the costumer receives a ticket with a number, which can be used and re-used for games on different levels, seems to be the most basic form. Still, a lottery ticket could become much more than a receipt; it could be perhaps like an information leaflet on relevant cultural heritage issues or on advocating local communities for awareness campaigns. Essential for the purchaser is to be informed about how his contribution will be used. Since lotteries have been practiced over centuries as a funding form, this verifies its sustainability. Additionally, the fact that beneficiaries can be modified according to needs, this makes lottery funds into one of the most efficient financiers also for built cultural heritage⁹⁶.

OMAS; Alternative financiers of built heritage					
Financier	Origin	Method	VP	Accelerators	Sustainability
Finance market	13 th century	CF	H ₃ UN	Financial (FA)	Self-sufficient; B,S/P
Lottery funds	300 b.c.	DF	H ₃ N	Financial (FA)	Self-sufficient; tickets

Table 664.1 Lottery funds according to the complete OMAS format.

6.7 Donors

6.7.1 Origin

To picture the prototype donor is impossible, but a large number of the most prominent philanthropists in the 21st Century are from the ranks of entrepreneurs or represent heirs of fortunes. The donor's capital assets might be allocated over a foundation but in contrast to the ones already discussed in chapter 4, the foundations of donors are strongly related to the single private founder, while the others presented in chapter 4, represent an anonymous group.

Benefactors endow financial support to enterprises they personally consider as challenging and if they have reasonable chance to succeed. Their personal fortune might be the outcome of a successful professional career enabling parts of their wealth to be spent as grants for charity, art, culture or education. Fortunate individuals have always been expected to shoulder key assignments in any society and share some of their wealth. Countries like the U.S, Denmark, Great Britain and

Germany have a long tradition of fund-raising from benefactors based on social, religious and cultural traditions. One of the major concerns for the financier is that the donations reach the final destinations without being reduced due to tax regulations or high administrative costs.

Donors active in Sweden are few by number; still some Swedish financiers are active abroad by contributing to school programs in South Africa⁹⁷ or have foundations that are available even for Swedish culture projects, though administered in the U.S.⁹⁸. In spite of the fact that donations to public universities are cut by one third for administrative costs⁹⁹ still some philanthropists are donating funding for education, such as the founder of IKEA Ingvar Kamprad¹⁰⁰. One of the most generous donators of culture heritage is the Ruben Rausing foundation which has contributed to archaeological excavations over the years¹⁰¹.

OMAS; Alternative financiers of built heritage					
Financier	Origin	Method	VP	Accelerators	Sustainability
Finance market	13 th century	CF	H,UN	Financial (FA)	Self-sufficient
Lottery funds	300 b.c.	DF	H,N	Financial (FA)	Self-sufficient
Donors	12 th century				

Table 671.1 Donors according to the OMAS format, here (O).

6.7.2 Methods; direct funding

Donation can either be allocated from a private individual, companies or via personal foundation as a direct funding. Due to the restricted policy concerning tax concessions for capital gifts from companies and private individuals, only a few donors are active in Sweden today¹⁰². Since personal foundations might be tax-exempt under certain conditions¹⁰³ Swedish cultural donations are first of all distributed this way and unfortunately become an impossible burden with the few exceptions of certain donors, as exemplified here by the Uppåkra case.

The financial support of archaeological investigation of the town of Uppåkra is one of the most recent donations to heritage in the south region of Sweden. This early medieval town¹⁰⁴ long since swallowed up by succeeding cultural development, once was one of the first town shaped settlements of Skåne province¹⁰⁵. The settlement was established around 1000 BC and the archaeological findings verify that it used to be of major importance for the trade in the area and consequently prosperous. Uppåkra was probably abandoned at the time of the unification of the Kingdom of Denmark but later on it became an important marketplace, parallel to the existing medieval town of Lund and inhabited until the early Middle Ages. In 1990 some archaeological findings were made with a

metal detector, which proved the significance of the site and that it was larger than the former prehistoric capital of Birka on Björkö, northeast of Stockholm. Thanks to private donations made by the Birgit and Gad Rausing foundation¹⁰⁶ the archaeological department at the university in Lund every summer has since been able to launch archaeological excavations at Uppåkra. The many artefacts revealed, even including some made out of precious metals, have been exhibited locally and guided tours of the excavations are arranged on a regular basis, during the excavation campaigns. Future plans which have been drawn up by local groups and the community are aiming at enlarging the excavations. A museum building especially is called for and additional ventures that in all possible ways, reveal Uppåkra's glorious past for the benefit of future generations. The regional office of Skåne¹⁰⁷ is preparing to increase the project and begin cooperating with Denmark, as the site is of mutual historical concern.

Uppåkra is an example of a project that not only could generate positive responses for Lund University and the Danish archaeological science departments, but has the potential to become a considerable historical site providing contextual enhancement from a growing cultural tourism¹⁰⁸ if more private funding could be acquired. In 2008 meetings were held to prepare applications for EU funds as public financing for the project was modest and in 2009 a foundation was set up¹⁰⁹.

OMAS; Alternative financiers of built heritage					
Financier	Origin	Method	VP	Accelerators	Sustainability
Finance market	13 th century	CF	H ₂ UN	Financial (FA)	Self-sufficient
Lottery funds	300 b.c.	DF	H ₃ N	Financial (FA)	Self-sufficient
Donors	12th century	DF			

Table 672.1 Donors according to the OMAS format, here (OM).

6.7.3 Accelerators; emotional and financial

Philanthropy is when a private individual donates part of a procured or inherited fortune to trustworthy projects within for example charity or culture, which have been carefully chosen. Today private fortunes do not automatically involve giving money donations, as was the case during medieval times when the Catholic Church offered salvations by selling letters of indulgence¹¹⁰, or it was believed, donations to the poor would secure paradise.

Though time has passed there is still a bond to be considered between donor and beneficiary, even today. It seems that the personal understanding of the benefactor is often decisive in the choice of which projects to fund and in the case of

built heritage; this would refer to the historic knowledge value (H_2). For example the Rausing donations logically support archaeological excavations because the founder was a trained archaeologist. For the same reason Ingvar Kamprad, with the interior design focus of his company IKEA, prefers to get involved in the sponsorship of an education in industrial design. Influential philanthropists most likely stimulate others to do the same and icons like Bill Gates will always be important role models. To follow good example can imply that a donation may also tell society of an individual's personal wealth and the medial attention it will bring becomes the trademark of success for the donor.

The essential link between recipient and donors reveals that donations would hardly come about at all unless this venture had good future prospects of operating profitably and this commitment concerns the utility value (U). Additionally, the nominal value (N) of a heritage is crucial which means that the financial investment must convey an economic win. The origin and methods of the donor groups show that an increase of funding could be managed for built heritage, when both the sentimental as well as the rational value preference (VP) according to the H_3 UNS concept are promoted as; H_2 UN. The historic knowledge value (H_2) relates to the deep knowledge of the subject of concern and is induced by the *emotional accelerators* (EA), stimulated by actions of information. The utility value (U) and the nominal value (N) represent the likely success for the recipient, which are perceived by *financial accelerators* (FA), stimulated by actions of actual or expected financial growth. The donor funding can be expressed as follows;

Acquiring funding from Donors via emotional and financial accelerators
 $(A+VP=V_A)$

$EA/FA+ H_2U += V_A$

A = EA, Emotional Accelerators of value initiate funding by actions of information, access

FA, Financial Accelerator initiate funding by the actions of actual/expected finance growth

VP= Value preference of donors; rational and sentimental H_2 , U, N

V_A = Value activating funding; direct funding

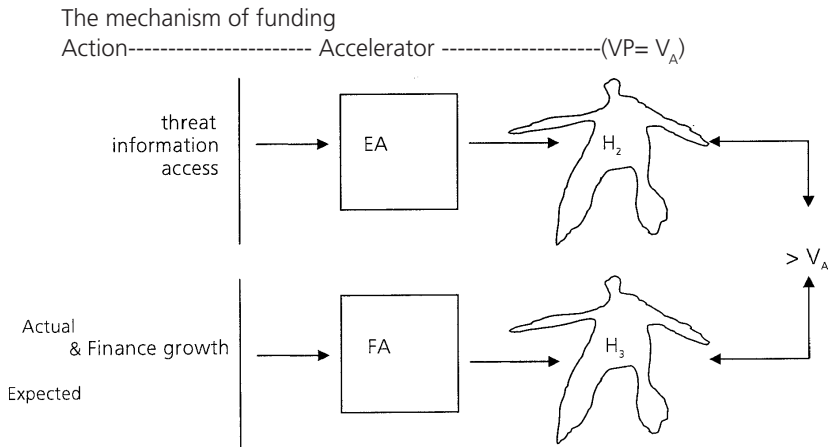

Figure 673.1 The mechanism of heritage funding of the donors, for the acquisition enhancement of new finance, requires actions of information, access and actual (a)/expected (e) finance growth, such as media, adaptations, tax concessions.

OMAS; Alternative financiers of built heritage					
Financier	Origin	Method	VP	Accelerators	Sustainability
Finance market	13 th century	CF	H ₂ UN	Financial (FA)	Self-sufficient
Lottery funds	300 b.c.	DF	H ₂ N	Financial (FA)	Self-sufficient
Donors	12th century	DF	H ₂ , H ₃	Emot. (EA) Fin.(FA)	

Table 673.2 Donors according to the OMAS format, here (OMA).

The accelerators which could make private donors see values in built heritage, and increase funding; have been identified as both emotional and financial. This implies that a social and economic climate exists nationally, which favours actions for donors to make heritage funding, referring in this case to; information, building adaptations and tax concessions. These stabilize the Historic knowledge value (H₂), the Utility value (U) and the Nominal value (N) in built cultural heritage.

6.7.4 Sustainability

For built heritage to come up as an alternative for donations on a regular basis, active information campaigns which provide awareness are essential. Medial promotion of historic buildings on television or the internet is most likely today's most efficient promotion form. Rational and realistic plans of what is to become of the built cultural legacy and how the conservation finance called for may be able to contribute to the common good, in a direct dialogue with future benefactors, would be essential. Preparation works of this kind would be useful for unit-

ing local historical groups and communities on a local level, even for drumming up support across generations, if schools were involved. New non-public mediator's equivalent to the NPOs might be required for this purpose.

OMAS; Alternative financiers of built heritage					
Financier	Origin	Method	VP	Accelerators	Sustainability
Finance market	13 th century	CF	H ₃ UN	Financial (FA)	Self-sufficient
Lottery funds	300 b.c.	DF	H ₃ N	Financial (FA)	Self-sufficient
Donors	12 th century	DF	H ₂ , H ₃	Emot. (EA) Fin.(FA)	Self-sufficient

Table 674.1 Donors according to the complete OMAS format.

6.8 Summary

Alternative funding solutions are called for if we are to keep the growing amount of built cultural heritage worldwide, hence the mechanism of funding of three financiers has been analysed; the investment market, the lottery funds and the financial donors.

Finance institutions on the capital market buy and sell assets for investors to augment capital though this can be risky at times. Actions of actual and expected finance growth indicate that financial accelerators (FA) match their value preference (V_p) with H_3UN when confronted with built cultural heritage. Investment options for the market therefore can be advertised through the media with historic quantity value (H_3) as key incentive to promote built heritage among laymen. In addition all potential profits are essential (U, N). The credit market utilized in the last seven centuries verifies its enduring and persistent nature and it has been implemented for building heritage in single nations since the 1980's. Monument investments even for private citizen's low-risk municipal bonds, or portfolios of shares established in buy back programs, would provide a general value rise.

The financiers of lottery funds are all private groups purchasing the tickets. The investment can be enhanced through broadcasting (H_3) and the sales of additional tickets raises the chances of winning or financial growth (N) and risk exposure in the higher ticket price. These actions refer to the financial accelerators (FA) and with built cultural heritage as beneficiaries, thus these actions correspond to the rational value preference (VP) of H_3N . The efficiency of lotteries as sustainable funding sources is verified by their consistent use over centuries in most nations and the current reuse of lotteries for building preservation.

Donors are well off private individuals willing to allocate finance support to encourage enterprises they consider having capacity to succeed; finance can ini-

tiate utility (U). Celebrities of charity funding are role models and these trademarks of solidity provide incentives for other groups such as actions of financial growth, stimulating the financial accelerator (FA). The experience objective of similar endeavours is as well vital for donors, which is why *actions* of information or access reveal the historic knowledge value (H_2), when induced by emotional accelerator (EA). Consequently, sentiment as well as rational value preferences, signify the private donators with VP; H_2U . Donations have frequently been applied in past hierarchical societies which is why they are affected by ideological traditions nationally.

Notes chapter 6

1. All form of ventures; from railroads, industrial productions, museums to tourist attractions. For example the AB Falsterbo Strandbad (Falsterbo beach Resort Company), which addressed the inclined investor in the second half of the 19th century.
2. For instance the recent expansion of the Malmo University *Orkanen* which could be launched thanks to German investors.
3. Venice was ruled by a trade oligarchy of strong shipping trade families, see Dillard (1997, p. 66f).
4. Brügge used to be called “the Venice of the North” and was later followed by Antwerpen, but then again replaced by Amsterdam in the 17th century, *ibid* (1997, p. 72).
5. Southern Germany with Ulm, Augsburg and Nürnberg, *ibid* (1997, p. 72f).
6. Later in the 17th century, see *ibid* (1997, p. 113ff).
7. The 18th century economist Adam Smith wrote the “The Wealth of Nations” in 1776, see Eklund (1995, 97f).
8. In order to avoid cartels or interest groups developing, which could jeopardize free competition on the market, Smith said. On the contrary the State must defend the free market against capitalists, *ibid* (1995, p. 97f).
9. The assumption that prices levels on goods would remain unchanged, no matter circumstances, is hardly likely, since customer’s evaluations or expectations are unpredictable. Additionally, collective goods, like education or pollution, which effect production negatively, cannot follow the market economy rules. Instead these have to be settled by public means, *ibid* (1995, p. 99f).
10. ... “nations that embody a well-functioning political democracy tend to have a business world that relates to market economy”, quotation from Bogdan (2003, p. 66f).
11. How to divide natural resources, what volumes to produce and how, may allow the state to eliminate unemployment, at least in theory. With the capacity of regulating economy, the public body can control salaries as well, see Eklund (1995, p. 99ff).
12. Steel, robots and aeroplanes, see Dillard (1997, p. 11).
13. A Polish expression to describe the inefficiency of the five year planning, quotation prof. Nowisca , Barbara (1998, lecture) Slavic Institution LU.
14. To encourage factory employees to reach their productivity quotas, a bonus was often handed out. For instance if a productivity goal was to manufacture a certain amount of beds, calculated in tons, then a production of very heavy cast iron beds began. In this way the factory had soon fulfilled their share and got their bonus, see Eklund (1995 p. 107f).
15. *“People in Poland used to have many jobs. In the morning you worked in a factory, but in the afternoon you went home and made leather bags, for instance. Meanwhile, someone covered for you during your absence from the factory. The bags you had made, were finally sold at the black market to a far better profit, than the factory salary ever could bring”*, quotation, Nowisca (1998).
16. *“I went to the black market to buy a wedding presents for my daughter, the shops are far to expensive”*, quotation from a Lithuanian architect (1997).
17. See Dillard (1997, p. 16).
18. *Ibid* (1997, p. 130).
19. Banks existed in Venice as early as in the 14th century, *ibid* (1997, p. 132).
20. Quotation from Byström (2007, p. 12) which continues... “the subject that deals with all the institutions and markets that makes up the financial sector” ... “a modern market economy”.
21. Such as banks, insurance companies or financial institutions.
22. The assumptions in economics are made *ceteris paribus*, which is Latin for “all other things being equal.” This signifies that for practical reasons all other consumers, other than the group studied, will behave the same way or be unaffected, in order to render an analysis

- possible, see Eklund (1995 p. 19f). In order to calculate a process, the different variables are generalized and simplified, to be comparable, see Byström (2007, p. 24).
23. Quotation from Peacock and Rizzo (2008, p. 1).
 24. Byström (2007, p. 18).
 25. Depending on what is customary in the individual nation. Germany has for instance a bank based investment tradition, while the U.S represents a marked based one, Black, B. and Gilson, B.(1998).
 26. The so called Dynamic Heterogeneous Panel, see Arestis, P., Luintel, A. D. and Luintel, K.B. (2005).
 27. Lord Turner (2009) The Turner Review. A regulatory response to the global banking crisis.
 28. All monetary assessments made, were compared only with the most recent value estimates and in this way no loss ever became evident, Forseke (2009, interview).
 29. The Credit Institute Lehman Brothers in this case played a central role.
 30. Forseke (2009, interview).
 31. Banks are involved in stock broking, currency trading and for this reason some have developed into commercial-, merchant-, investments- and saving banks. On the other hand institutions and the market have begun to perform the same services as banks, see Byström (2007, p. 18f).
 32. The assets can be ether stocks, bonds, commodities or private firms and other less secure funds, Ibid (2007, p. 19f).
 33. For example Government bonds or stocks representing a technically advanced industry, see ibid (2007, p. 20f).
 34. Commodity-, future-, electricity exchanges to mention a few. To generate a reasonable profit, a certain volume is essential to reach, which then could be bought and sold, ibid (2007, p. 20f).
 35. There have been bonds with maturities of 30 years, ibid (2007, p. 21).
 36. Ibid (2007, p. 22).
 37. The traders choices are either fossil fuel, natural gas, precious metal, cotton or coffee, ibid (2007, p. 23).
 38. See Byström (2007, 24). Problems will for instance occur since airlines will continue to sell cheap flight tickets also when the aircraft fuel forwards mature. The airline company for this reason has to pay the spot price for fuel.
 39. Ibid (2007, p. 24f).
 40. Ibid (2007, p. 24f). Property investment firms assist the capitalists in finding suitable estates on national or foreign markets. The deal usually involves a 10-15 year investment commitment which could bring good proceeds if the value increased as expected.
 41. FSA (2009, p. 14).
 42. The responsible parties were many, such as; the rating agencies, the regulators, the politicians and the investment banks, Forseke (2009, interview).
 43. FSA (2009, p. 7).
 44. Forseke (2009, interview).
 45. Wealth, such as employment. Trade brought nevertheless prosperity in other aspects as well, for instance culture, education and knowledge. Regions or countries which were less developed, but which had a flourishing trade, for this reason invited monasteries to get settled which was the case in Vilnius during the 14th century, see Skarin Pålsson (2001, p. 41).
 46. Traditional building materials applied in the past are possible to maintain, which hardly ever is the case, or even the idea, with new constructions of today. However it might be possible to recycle as raw materials for other products.
 47. Like the New York Landmarks Conservancy, see chapter 4.
 48. See Burnham (1997, p. 86).

49. Forms of condominiums, tenant-ownership or that the square meters would be linked to ownership and future use. However, in this case a contract, equivalent to the easement-deal, would be essential to set up, which proscribes maintenance obligations.
50. The South Street Seaport area, in Downtown Manhattan in New York.
51. Kluger, see chapter 1 and Björklund (ed) 2003, p. 397-402.
52. Forseke (2009, interview).
53. Ibid (2009, interview). Especially when the future use of a church can bring returns (concerts or exhibitions).
54. "Talented managers are most likely to invest their human capital in a company financed by a respected venture capital fund, because the venture capitalist's participation provide a credible signal about the companies likelihood of success", Quotation from Black and Gilson(1998, p. 254). "*When influential funds distribute grants for a project they influence individuals and put focus on a particular issue in conservation. What they do, has an impact that the heritage can gain on*", quotation from Morgen (2008, interview).
55. The wall was constructed during the Hang dynasty, 205-187 b.c., Lottery history (2009, Web).
56. The Dutch word for fate "lot" is still reminiscent of the early Dutch initiative ibid (2009, Web).
57. Lotteries were abolished in Britain in 1826, but legalized again in 1934, see Creigh-Tytle (1998, p. 193). In Sweden Gustav III's lottery fund *Nummerlotteriet* from 1772 was banned in 1841 until the end of the 19th century, Hutz (2004, p. 174f).
58. Princeton- and Columbia University, Lottery history (2009, Web).
59. More than 116 new lottery funds only in 1992, see Boorsma (1998, p. 193).
60. Secretary of State for Culture, Media and Sport.
61. The "Trollhätte – Slussverkslotteriet" had a monopoly as lottery fund between 1762-72 and the royal lottery, Nummerlotteriet was its predecessor, active until 1841 when lotteries as such were abolished. The large exhibition and culture lotteries were established in 1896 and they were run by the private Lotteriexpeditionen until 1939 when they were nationalised and the Lotterimedelsfonden was set up, Statens Offentliga Utredningar (SOU1965:10, p. 46) and Hutz (2004, p. 174ff).
62. Five million SEK, ibid (SOU 1965:10, p. 35). This was approximately about 125 millions SEK in 2007.
63. The private result pool for football was established in 1934 and nationalized in 1939 and is today included in Svenska Spel. Their turnover was 4,7 billion SEK 2010, but for culture only 48 000 was allocated, Söderqvist, J. (2011, interview).
64. Glücks Spirale (2008, Web).
65. The Deutsche Stiftung Denkmalschutz is on of its beneficiaries.
66. Stiftung Natur und Umwelt.
67. Since 1994, HLF (2004, p. 2).
68. The National Land Fund was abolished and replaced by National Heritage Memorial Fund, ibid (2004, p. 2)
69. Spanish National Lottery has been an important role models for the British lotteries, Munger (2004, interview).
70. The others are sports, arts, charities and culture, HLF (2004)
71. The organisation Arts & Business has a register over the enterprises that support the HLF, Munger (2004, interview).
72. "From every pound 4.66p", quotation from the HLF (2004, p. 2)
73. It includes everything which is important for people such as parks, landscapes, industrial heritage or townscape, HLF (2004, p. 3f)
74. Projects like; "Public parks initiatives", "Townscape heritages initiatives" or "Young roots", to mention a few, ibid (2004, p. 4).
75. Munger (2004, interview).

76. Ibid (2004, interview).
77. Lotterimedelsfonden, SOU1965:10, (1965, p. 46).
78. The Bingo Lotto was introduced on local television as early as in 1989 and in a new private one *Channel 4*, which was established in 1991.
79. Purchased by the *Folkrorelsernas Samarbetsorgan*, Skoglund (2008, interview). *Folkrorelsernas Samarbetsorgan* and their sub-organisation *Folkspel* (Peoples game) administrate a number of lotteries and bingoes where the revenues are allocated to sport or leisure associations all over Sweden or as prize awards, annually, Folkspel (2009, Web).
80. Bonnier Entertainment is a subsidiary company to the Bonnier AB Publishing house.
81. All 75 organizations receive funding on a yearly basis and 80% of them are sport associations, Skoglund (2008, interview).
82. Bingo Lotto (2009, Web).
83. The nominees are awarded in categories such as; the year's *Enthusiast*, *Association* or *Leader*, Bingo lotto (2008, Web).
84. Children active in the sport association are expected to take part in the vending of lottery tickets during the year and this has been much discussed lately since it is illegal to exploit those under aged. However, the income which it brings is most essential for the sport associations.
85. The company's annual turnover from the lotteries in Holland, Sweden, Scotland and England is 6 billion (miljarder) SEK, Postkodslotteriet (2008, Web).
86. Through entertainment, high esteemed prizes and an offensive marketing, ibid (2008, Web).
87. The beneficiaries are; Alzheimerfonden, Cancerfonden, Bris, Hjärt-lungfonden, Läkare utan gränser, Rädda barnen, Sjöräddningssällskapet, Svenska Röda Korset and Världsnaturfonden WWF, ibid (2008, Web).
88. The assets in the Post Code foundation, the Postkodsstiftelsen, is not earmarked for any special purpose and its revenue is spent wherever the company considers finance support is needed, ibid (Web, 2008).
89. In 2007 the turnover was 931 million SEK. Since 2005 the lottery has donated 270 millions to its beneficiaries, Postkod lotteriet, ibid (2008, Web).
90. Skoglund (2008, Interview).
91. Humanitarian aid, the ecological approach and issues on climate change.
92. See chapter 5.
93. "To create a local commitment across the generation gaps and widening the definition of heritage to apply for all that are "important for people such as parks, landscapes, industrial heritage or townscapes", quotation from HLF (2004, p. 2f).
94. The Red Cross or Foundations for cancer research.
95. See chapter 5.
96. "Privatization in the form of reducing public funds calls for other funds e.g. from lottery", quotation from, Boorsma et al (1998, p. 205).
97. The Star school for children effected by the spreading of AIDS and supported by the financier Dan Olofsson, see Ström Melvinger (2008).
98. See Braw (2007). The *Bernard Osher Foundation* was established in San Francisco, USA, in 1977. Mrs Barbro Osher is the president of the joining *Pro Suecia Foundation*, which grants Swedish cultural and educational project in North America and Sweden, Osher Foundation (2009, Web).
99. The Lund University subtract 35% as overhead costs on all donated means, see Bosson (2008).
100. Ingvar Kamprad's donation to Lund University for the Industrial Design program, which included the new construction of the IKDC annex in the 1990's and grants to science from donors like the Crafoord foundation.

101. A number of foundations exist in Sweden, which annually contribute with minor sums for individuals for education purposes. However, a foundation cannot be exempted from tax unless its purpose fulfils one of the legally set up goals; prevent poverty, army/ defence, children, Scandinavian cooperation, education and science. Neither culture missions nor building conservation qualify foundations to tax- exemptions.
102. Slovakia and Sweden are the only countries in Europe which disapprove of tax- exemption on capital gifts, see Skogskär (2008). During 2010, even Slovakia has evidently introduced some form of tax concessions as well.
103. Associations and foundations with specified aims in the constitutions for the common good, might attain tax concessions on income, Ljungberg (2009, interview), see note 101.
104. The ancient Uppåkra site is south west of the contemporary and medieval city of Lund.
105. Uppåkra (2008, Web).
106. Birgit and Gad Rausing Stiftelse för Humanistisk Forskning was established abroad, in 1995. Gad Rausing was the son of Ruben Rausing; one of the founders of Åkerlund & Rausing and the Tetra Pak industries in Lund, Rausing (2009, Web).
107. Tuveson (2008, Interview).
108. Increase in employment, museums, hotels and restaurants.
109. Stiftelsen Uppåkra Arkeologiska Center. The last two years (2009-2010) 10 000 Euro additionally has been granted to the project site (tent, information) from the municipality, state and a private bank foundation, by 1/3 each. In the spring of 2011 they hope to receive 60 000 Euro, Mårtensson, N-O (2010, interview).
110. Used for rebuilding or maintenance on churches, see Jacobi Kirche, Skarin Pålsson (2001, p. 128).

7. Economizing and Assuring funding

7.1 Introduction

In order to tackle the growing finance deficit in heritage economics, out of the three methods proposed in this finance model – acquiring heritage funding has been the most urgent one to explore. In this chapter consequently the two additional targets of the finance model are analysed, concerning step 4 – what measures to take for *economizing* (C_{SAP}) funding¹ and moreover step 5 – the *assuring* (V_B) of heritage funding². In view of the fact that only building conservation in practice can provide some realistic answers to the proposed theories on economizing and assuring funding, three restoration cases have been used as examples for these final inquiries. Two of the projects are German; the St. Jakobi church in Stralsund, the Rossewitz Palace near Güstrow and the third one is the British refurbishment of Murray's Mills in Ascot, Manchester.

7.2 Step 4; Economizing funding (C_{SAP}) – Intentional distribution and vertical archaeology

The accurate costs (C) for building conservations are difficult to estimate since these not only are due to the physical condition or extent of the constructional damages in the built heritage. This would only be the case if building protections followed a set standard and could be arranged as a highly industrialised process, but this is hardly ever the case in practice. Historical buildings are indeed constructed out of a limited number of building materials³ and so the maintenance expenditures could be calculable in theory, the same as the reoccurring mechanical damages of wear and tear are predictable. The practical reality is yet far more complex, since every conservation venture reveals unique or unforeseeable situations to confront, constantly adding to the expenses. These can either be linked to exterior conditions at the site or ownership transferences⁴, but not least are due to the diverse value preferences among the many professionals involved, which reflect the fact that conservations must invariably fulfil a variety of expectations.

In contradiction to new constructions, which are developed through the drawings of one architect's vision, the built heritage is far more engaging due to its full scale and three dimensional shapes. Generally it can be said that the more capital allocated on single prestigious or historically significant building conservation missions, the more obvious these challenges become and the less efficiently funding tends to be utilized for actual building measures⁵. This is why some are convinced that long-lasting preservation ventures might be more favourable for cultural heritage.

The standard succession of *building phases*⁶, which each refer to separate costs, should ideally progress according to a logical succession in conservation practice, by starting with the protective measures on the exterior shell and end up with the interior mouldings. This used to be applied, at least in theory, while the extensive and complex masonry preservation ventures were few in number, either as built legacy was regarded less valuable, in the way which industrial complexes are to palaces, or while funding was more adequate.

New and urgent challenges were however exposed as former, isolated Eastern Europe opened up to the rest of the world in the 1990's, revealing a precious and neglected, but still intact, built legacy. Here finance would hardly be sufficient for the standard conservation model and this was why new *intentional* building phase *distributions* had to be developed to economize funding according to the money at hand. Now the built legacy itself came to play the leading part in new marketing, not as costly building ventures but as the indispensable assets. This so-called *vertical archaeology* with layers of time was then used to trigger the motivation for funding, as applied for instance at the Frauen Kirche in Dresden, Germany. From now on the conservation measures, revealed in the building phase successions themselves became the *actions*, equivalent to external conditions⁷ stimulating the accelerators of the human perception, hence re-establishing value for the built heritage. Its former appreciation had regrettably often gone lost due to a well-organized ideological policy which had been renouncing this 3D proof of the past⁸. The value resurrection of built legacy was most essential to induce in order to establish any private or public funding.

Significant for the new approach was therefore to commence conservation work on the building sites immediately, as soon as the first subsidy became available, instead of waiting to begin until the complete calculated estimates were available; an approach which might have saved New Maglarp Church. Even minor preservation works begun since the drive to expose changes and protect built heritage came into force, sequentially brought additional incentives to other groups to contribute. The motivation to preserve historic buildings in other words outnumbered the budget inadequacies. Maybe the work phase's ability in building conservations, to enhance monument value, should instead more of-

ten be intentionally planned, since this seems to be an idle recourse that is vital for funding. Considering that preservation works are never-ending due to the constant weathering of materials, preservation works will consequently never be finalised. Intentional planning of the distribution of building phases, according to size and property order, could in this way finally be used to economize funding for all restoration practice.

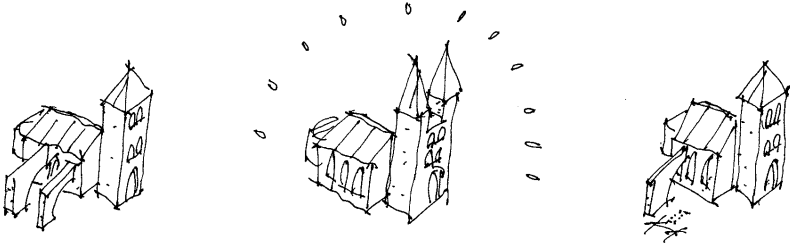

Figure 72.1 Intentional distribution of building phases in building conservations, according to size and property order, could both promote built cultural heritage better for financiers, just as does economize funding. To get started, though the budget is insufficient, could be essential since attempts motivate new groups to support.

A general subdivision of the major building phase in conservation projects can be regarded as enclosing the following three items of expenditure; shell-repair (S), adaptation (A) and preservation (P). All safety measures of constructions exposed to the exterior climate refer to *shell-repair* costs (C_s). The measures here generated and its expenditures often turn out to be higher than initially expected, especially in large complexes, since they are the most complicated to assess⁹. Funding is often problematic to attain for some of these measures since they lead to less obvious results to the laymen's eye and rarely qualifies for public subsidy¹⁰ since it is funding referring to maintenance. However, this is counterbalanced by the positive impact that newly restored façades have on their surroundings, this is indisputable and well understood by entrepreneurs as well as financiers.

All expenses which are linked to modernisations, such as when the built heritage is re-adapted deliberately to fulfil contemporary modern needs and requirements for use, these are classified as *adaptation* costs (C_A). Finally, the detailed and skilled workmanship on the interior or on exceptionally decorative parts of the exterior mouldings is linked to the *preservation* costs (C_p). These scientifically incited works normally can acquire public means. The building phases outlined here, and discussed in the three real-life examples, include all other corresponding and additional overheads of the individual measures; from management planning, constructional materials, building site establishments, to salaries.

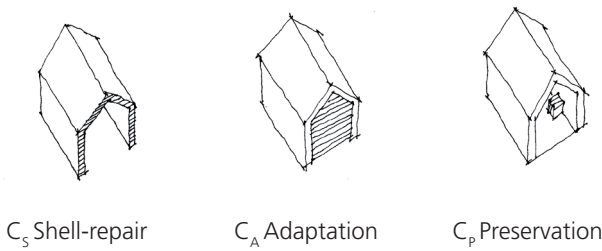

Figure 72.2 $C_S + C_A + C_P = C_{SAP}$, that is to say cost or expenditures including all corresponding overheads from planning, building materials to salaries for Shell-repair, Adaptation, Preservation.

If the built legacy itself plays the leading part in economizing funding, the conservation measures or work phases (C_{SAP}) of buildings in this way become the *actions* at the sites, which stimulate the accelerators. As verified in the previous chapters only the emotional (EA) and financial (FA) accelerators have the capacity to re-establish and market values of the H_3UN_S concept as an index, to human perception, which are so essential for future finance.

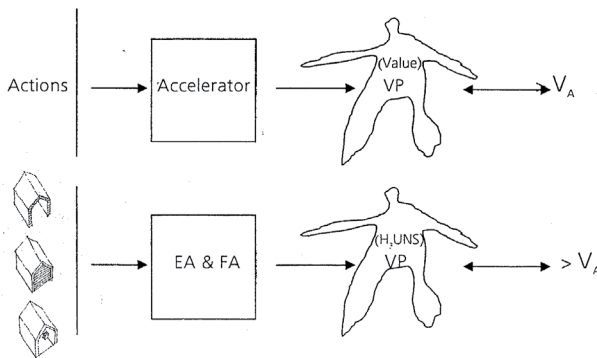

Figure 72.3 Just like the mechanism of funding; actions- accelerator-value relation, the economizing of funding entails that conservation measures or work phases (C_{SAP}) become the actions, which stimulate accelerators so people see values or qualities in built cultural heritage.

How intentional and scrupulous the building phases are distributed in conservation practice must consequently have significance. This indicates that the phases in various degrees can be inspiring for either or both of the emotional or the financial accelerator. The final question is undoubtedly how the individual building phases (C_{SAP}) relate to the two groups of value inducing accelerators; EA and FA, where only conservation practice may provide the answer, as illustrated below.

Roofs are always considered as one of the most exposed and delicate building parts of shell constructions, in the field of building conservation, since the condition of the roof is decisive when it comes to the state of damage. An urgent shell-repair (C_s) involving roofs or just constructional safety measures may only generate a minor value growth for built heritage among laymen. Yet when including the facades, the capacity of this building phase has proved to create extensive financial growth for the whole neighbourhood¹¹. This is why safety measures for the complete building “shell” are mandatory if one wishes to induce the historic quantity value (H_3) rise. As revealed already in Study 1 the respondents working in the conservation projects were convinced that preservations in general contributed to a value increase for built legacy¹² by enabling intellectual and physical access to heritage, thereby increasing the historic qualitative value (H_1) as well. Shell-repair for this reason can be said to represent *actions* of access and finance growth. As a result of this, shell-repair corresponds to emotional and financial accelerators; $C_s - EA/FA - H_1/H_3$.

A minor adaptation (C_A), for instance to a restaurant, will allow an actual financial growth, thanks to a renewed utilization and strengthening the utility value (U). Every new business requires capital which is why plans for a restaurant adaptation can signal expected value increase to other financiers willing to support and in so doing renewal projects come to concern the nominal value (N) as well. Furthermore, any adaptation will always in succession ensure the good condition of the roof. Adaptations could represent *actions* of actual and expected finance growth. Therefore adaptations correspond to financial accelerators; $C_A - FA - UN$.

If the sum allocated for the “restaurant” were offered to the heritage authority experts they would most likely choose to subsidise preservation (C_p) works instead. For instance a partially damaged interior stucco ceiling of original substance in the “restaurant”, by an ancient stucco master, would automatically gain a higher priority. A limited investment for restoring broken parts could increase vital knowledge of the craftsmanship involved in theory and in practice, thus inducing the historic knowledge value (H_2). Preservation (C_p) can consequently be said to represent *action* of information and is linked to emotional accelerators; $C_p - EA - H_2$.

A pragmatic ranking order according to priority would state that the roof’s protection should be the most imperative to secure, due to its exposure; though this is less appreciated by the laymen¹³. However, the costs for a complete roof repair exceed the expenditures for the adaptation described. Though only parts of the roof may need urgent maintenance, still all funding will often be spent on its completion. In this way less will be left for the facades (FA) or to enable information or access to the site (EA). The excellent opportunity for a value enhancement through the stimulation of accelerators, which is the basics for acquiring funding,

will in this way be lost¹⁴. On the other hand, restorations of reduced sizes according to preservation urgency for damage prevention and a flexible distribution of the different building phases (C_{SAP}) might instead be one way to cut back expenses for the proprietor or for future generations.

Intentional distribution of building phases involves allocating the funding available so the value enhancing accelerators; emotional (EA) and financial (FA), can promote as secure, funding from investors or financiers. A more flexible approach in the restoration practice would then be in planning for a distribution of the work phases in priority order and size, representing costs or items of expenditures in the accounts, all of which will concern more parties in society. In this case the conservation should both include the partial, but urgent roof repairs, the restaurant adaptation and the preservation of stucco ceilings.

Figure 72.4-1 outlines the relation of the building phase's "action abilities", inducing the accelerators for all people to perceive its values. The effect of combined intentional distribution C_{SAP} for the finance management model is illustrated in the table below 72.4-2.

$F + V_A - C_{SAP} = V_B$ Finance model with cost for Shell-repair (S), Adaptation (A), Preservation (P)

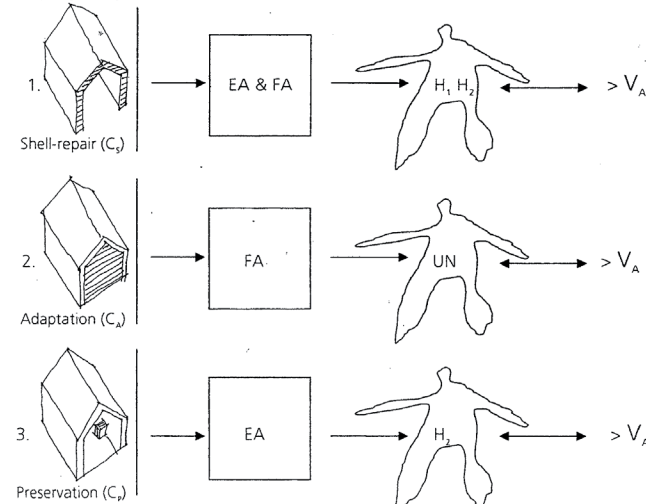

1. $F + V_A - C_s = V_B$ Finance Model with Shell-repair (S).....
...instigates actions of access and (a/e) finance growth via E/F accelerators to perceive historic quality & quantity value (H₁, H₂).
2. $F + V_A - C_a = V_B$ Finance Model with Adaptation (A)....
...instigates actions of (a/e) finance growth via financial accelerators to perceive utility & nominal value (UN).
3. $F + V_A - C_p = V_B$ Finance Model with Preservation (P)....
...instigates actions of information via emotional accelerators of historic knowledge value (H_j).

Figure 72.4-1. The illustration outlines the relation of the building phase's "action abilities", inducing the accelerators of people to perceive values in built heritage.

$F + V_A - C_{SAP} = V_B$
 Finance model of Shell-repair (S) with Adaptation (A) or Preservation (P)

Actions-----	Accelerators-----	Values
1. $F + V_A - C_S = V_B$ Shell-repair (S)	EA/FA	$H_1 H_3$
2. $F + V_A - C_{SA} = V_B$ Shell-repair (S)+Adaptation (A)	EA/FA	$H_{1-3} UN$
3. $F + V_A - C_{SP} = V_B$ Shell-repair (S)+Preservation (P)	EA/FA	H_{1-2-3}

Table 72.4-2 To maintain historic buildings only the shell-repair costs are imperative (1) in building conservation. If combined with adaptation (2) both technical and modernisation requests, are fulfilled, which encourage the most values. When combined with preservation (3) both technical and skilful repair of original interiors is secured.

When the *vertical archaeology* (VA) of the built cultural heritage is exposed to people, which is possible to do during building conservations, this could generate income by passing on new knowledge gained during the period of construction, as the Frauen Kirche in Dresden, Germany exemplified¹⁵. The reunion of the German states and private donations enabled this church reconstruction in 2005. During the nine-year-long restoration, the church was open to the public and this generated equally much of an income as it did opportunities for discussing this controversial venture. A majority of the intrinsic practical skills; socially as well as theoretically, and the knowledge attained by the professionals during monument protections, is normally never available to outsiders. Even if detailed documentations are published they have limited capacity to assemble the human experiences of the professionals involved. Vertical archaeology exposure however, with the dimension of time objectified in the ancient structures, will for this reason always be of public interest and constitutes an often neglected income potential.



72.5. Frauen Kirche in Dresden before and after the reconstruction 2005.

Intentional distributions of building phases, which refer to the separate costs, (C_{SAP}) in the conservation practice, might be applied as a tool in order to economize funding by marketing the legacy based on two perspectives. Firstly, the detailed planning of the conservation works could be employed more resourcefully for value advocacy, for likely financiers, by regulating the building phases in relation to size, priority order and capacity, as *actions* to stimulate the accelerators, (see table 72.6). Secondly, promotion concerning making use of the vertical archaeology, such as knowledge and memory asset, could be applied for generating proceeds, by making the building sites publicly accessible. The options of intentional distribution of the building phases have been further discussed based on three building conservation projects from practice.

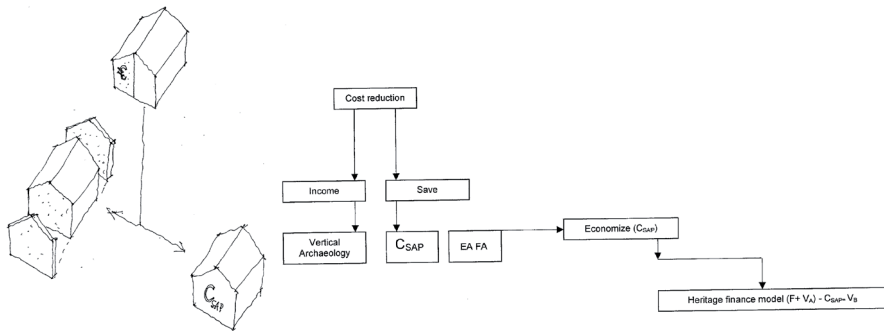

Figure 72.6 Intentional distribution of building phases could be considered as a tool for economizing heritage funding. Firstly by detailed planning of conservation works, which turns building sites to actions to stimulate the accelerators. Secondly, intentional distribution makes use of buildings' vertical archaeology, such as knowledge and memory asset.

Economize heritage funding							
Content funding models						Financiers	
Order	Size	Vertical Archaeology	Accelerators	Value Preference	Private	Public	Alternative
Cost for Shell-repair C_s			EA & FA	H ₁ , H ₂	F/NPO/AG	P/A	FM/L
Cost for Adaptation C_a			FA	UN	NPO	P	FM/L/D
Cost for Preservation C_p			EA	H ₂	F/AG	A	D

Table 72.7 To apply intention distribution of building phases for value advocacy, entail that shell-repair (C_s) is included, which induces value preferences of a majority of the financiers, while preservation (C_p) does the least.

Private funding: Foundations (F), NPOs, Advocacy Group (AG)

Public funding: politicians (P), authorities (A)

Alternative funding: Finance market (FM), Lottery funds (L), Donors (D)

The operational finance model strategy including the suggested economizing by intentional distribution of the building phases is expressed as follows;

An operational finance model must ensure that finance (F) can be acquired (V_A), economized (C_{SAP}) through intentional distribution and assured by achieving best possible future gain for built cultural heritage

7.3 Step 5; Assuring funding (V_B)

– employing empirical experience and the accelerators

To guarantee that the value stabilizing finance model will be sustainable; all outcomes of the protection have to convey *best possible future gain* for built cultural heritage, which assures future heritage funding. This involves both physical condition, as well as the value enticement capacity of the historic buildings, from this point onward, to nourish heritage funding.

Physical durability of historical constructions was clearly verified in Study 1, during the survey of conservation sites in Eastern Europe. Here the conservation project could repeatedly confirm that it was the high quality of original constructions and materials¹⁶ which motivated financing, so that even the apparently most impossible ventures became worthwhile. Regardless of the former neglected maintenance of built heritage for decades, its exposure to fires or the absence of roofs, the heritage was nevertheless, still preserved. This was possible due to the fact that the solid constructions at the heritage sites signified empirically developed technical knowledge of house building which has been applied over centuries. Likewise the New Maglarp case disclosed that, though the church had been ignored for 40 years, a majority of its brickwork could be re-used for a new building complex¹⁷. Only a rare few of our modern buildings of today would have the quality to ever withstand this sort of weathering exposure.

When building conservations are executed according to the original settings of the built structures, their values are secured. Technical problems have often been shown to occur when the ancient structures are confronted with new and modern solutions. These have been exposed and tested far less in outdoor climates, as regards durability and compatibility. The potential damage when replacing the original solutions with modern ones¹⁸ hence will increase the risk of causing future damages. In other words unqualified and less considered replacements will, as actions, induce the financial accelerators (FA) negatively to arouse economic failure and decrease the nominal value (N) since they generate unexpected costs.

This is why the empirically tested solutions should be used to ensure its physical condition and to avoid value decreasing loss of original building fabric.

Conservation of a building cannot be executed once and for all, due to the weathering of materials. This makes the protection requirement perpetual, but possible, and so its finance support has to be of the revolving kind. For this reason steps have to be taken so financiers will remain inclined to continue their support. Experience verifies that funding from one party may offer incentives for others to follow, as the essential notion of positive expectations will become established, which is essential for economic behaviour. With the assumption that values in historic buildings are incessantly present, they are also revivable when stabilized by accelerators, in turn stimulated by actions¹⁹. In other words the mechanisms of funding will be strong as long as the outcome of the conservation; the preserved built heritage, as the action, will continue to stimulate accelerators, so that benefactors may perceive their own value preferences in the built heritage²⁰.

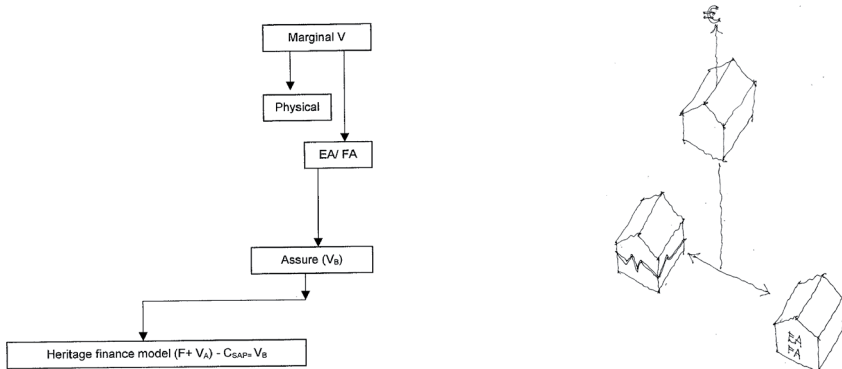

Figure 73.1 Assuring funding, which entails that the preserved heritage must provide a future gain, thus un-empirical conservation measures are excluded and historic buildings never fail to stimulate the emotional and financial accelerators

The expression “best possible future gain” in the finance model thus refers to the fact that the protected built heritage arrives at a positive marginal value (V_B), just as the “Value activating finance” (V_A) is required for funding to commence. The final outcome thus has to offer a new value which advances the one which initially was assessed, in order to justify the spending made so that; $V_B > V_A$. To achieve a sustainable finance model the *future gain*; the preserved heritage to society, will firstly be ensured so that un-empirical conservation measures will be avoided, which might cause damage and lead to unexpected costs. Secondly the protected built cultural heritage must never fail to stimulate the emotional and financial accelerators so as to attain a revolving funding.

The operational finance model including the sustainability perspective; dividend is expressed as follows;

An operational finance model must ensure that finance (F) can be acquired (V_A), economized (C_{SAP}) through intentional distribution and assured (V_B) by achieving best possible future gain for the built cultural heritage

7.4 Three case studies; – St. Jakobi Church, Rossewiz palace, Murray’s Mills

In this paragraph, three compatible real-life conservation sites have been investigated firstly with the purpose of distinguishing the use of an intentional distribution of the building phase of costs, C_{SAP} to economize funding, either for marketing as value or as vertical archaeology assets for income. Secondly, the real-life examples have been scrutinized based on their ability to generate revolving funding by assuring a future gain, which involves their physical conditions and capacity to encourage the accelerators. The projects described are large brick complexes which were initiated in the 1990’s and still remain incomplete; St. Jakobi Church, the Rossewitz Palace and Murray’s Mills²¹.

7.4.1. St. Jakobi Church²², Stralsund Germany



74.1 St. Jakobi Church during conservation works in 2006 (left) and as Kulturkirche in 2009 (right). Characteristics; Early medieval Baltic brick church and as one of the few of its time, originally built as a basilica.

The main altarpiece of the basilica Saint Jakobi, in Stralsund, was inaugurated in 1351 and in the 15th century its tower was erected. During the 17th century and the siege by Wallenstein, the church was severely damaged and 200 years later Napoleon with his troops used the church as a prison and horse stable. An explosion in the harbour in the 19th century once more initiated rebuilding works of the masonry facades. The allied bombings of Stralsund in 1944 totally wiped out the medieval building blocks surrounding the church, which was left fairly intact. For ideological as well as practical reasons, the tower's interior was rebuilt interiorly as meeting rooms in the 1950's while the nave was re-used as a mechanical workshop and storage for altar pieces.

The merger²³ of East with West Germany enabled funding, for an extensive conservation and adaptation of the church, to be allocated to the building in 1990. Just recently the former sacred church was inaugurated as a museum and theatre; Kulturkirche St. Jakobi. The future utilization of the church had been decided early on and these plans; *Nützungskonzept*, remained unchanged. Shell-repairs (C_s) were carried out during the first ten years and the rebuilding of the interior (C_A) began around 2000.

The church has remained accessible to the public for exhibitions and concerts during the whole construction period with the purpose of ensuring the public awareness, though this was at times complicated²⁴. The preservation and adaptation of the church had, and still has, an immense social significance for the city of Stralsund²⁵. The refurbishment and in particular, how to solve the issue of the fire safety was one of the most complicated matters²⁶. The organ and main altar piece are still awaiting attention in order to be preserved. Kulturkirche St. Jakobi is a privately funded project²⁷.

7.4.2 Rossewiz palace²⁸, Güstrow Germany



742.1 Rossewiz palace in the early 1990's (left) and in 2009 (right). Characteristics; One of few remaining early baroque palaces in the region, The architecture manifest by the architect Dieussart "Theatrum Architecturae" is an exclusive description of the Rossewitz palace design, with technical innovations, of its

time. The illusionistic perspective wall paintings are considered to be unique for northern Europe, and were perhaps copied by architect Tessin senior in Stockholm.

On top of the vaulted basement of the 14th century stronghold of Roosenytze²⁹ this early baroque palace Rossewiz was erected in 1682 for the nobleman von Vieregge and designed by the Italian architect Charle Philippe Dieussart (1625-1695). A bankruptcy forced the family to sell Rossewiz to the duke of Schwerin³⁰ in the 18th century and in the 1920's conservation works were carried out following a period of neglect, as the palace was to be sold, but it was eventually turned over to a leaseholder. The last tenant was forced to move after 1945 when Rossewiz was nationalized, therefore confiscated by the local municipality and instead used as refugee lodgings for east Germans³¹. As the last of these families moved out in the 1970's, an alternative use as hotel was suggested for the vacant building. However, in 1982 local politicians³² prepared plans to blow up the 17th century palace. Protests from private individuals managed nevertheless to put a stop to the demolition plans, but in a retaliatory move, the municipality instead unlocked the palace doors and by so doing give tacit license for anyone to plunder the "Junker"³³ palace. As the last glanced tiles 'disappeared', the roof-truss finally gave way and the palace's sudden risky condition was enough to trigger a local private group; *Förderverein*, to collect the sufficient finance to reconstruct a temporary roof in 1985.

When the storm blew off the protective roof and the local group once more applied for funding for its re-erection, this finally initiated the building conservation project proper of Rossewiz . The extensive restoration began in 1992 as finance was made available due to the merger of East with West Germany, *die Wende*. After months of clearing out the 3 m high heaps of fallen roof truss and wooden floor constructions³⁴ the shell-repairs (C_s) could begin. These were carried out until 1999³⁵ when the load bearing constructions were stabilized. Unfortunately the shell-repairs were never completed and the facades still remain to be conserved³⁶. The building has been closed for public access ever since Rossewitz palace was sold for a symbolic sum³⁷ to a private investor in 2004. The only preventive works carried out in the last decade have been on the illusionistic perspectives paintings in the Piano Nobile, which have continuously been preserved (C_p) since these qualify for grants³⁸.

During the first seven years of building conservation work, events were constantly held on the building site with the obvious intention of erasing the manor's bad reputation in the community as a haunted house or anti-socialistic *Junker Schloss*. A number of concerts were for this reason organized on every occasion to celebrate the project's progression; as soon as all the rubbish was cleared out of from the ground floor or when the mezzanine floor joist finally was in place³⁹.

Tours for visitors were arranged and naming stones offered to all groups of individuals who might be inclined to fund, as the chess patterned entrance floor was re-laid. The happenings provided some income but not least advocacy for the palace protection. In the same way the publication of a facsimile reprint of architect Dieussart's manifesto on Rossewiz *Theatrum Architecturae* was able to re-establish some of the palace's former glory as the book described in detail all the design intentions; from Dieussart's original layout plan to the intricate heating system installed⁴⁰. Sadly this whole conservation venture came to an abrupt end when the municipality disposed of the palace, selling it to a private proprietor. This is why today the baroque palace still stands empty and its future function still remains unsettled⁴¹. Rossewiz palace is a publicly funded project⁴².

7.4.3 Murray's Mills⁴³, Ancoats in Manchester, Great Britain



743.1 Murray's Mills an 19th century illustration (left) and its exterior in 2008, (source Murray's Mills Web). Characteristics; the cotton mill was the first steam-powered factory in the industrial suburb Ancoats. The basin connecting the mill to the surrounding canal was the vital transport route for coal and cotton. The industrial complex was still in use in the middle of the 20th century and refurbished with reinforced joists.

The Scottish industrialist Adam Murray built these steam-powered cotton spinning mills in 1806 in the industrial suburb Ancoats, on the east side of Manchester. The industrial complex was laid out as two separate cotton spinning mills; Decker Mill and the New Mill, which were joined together by two warehouses. The whole complex was surrounded by the waterway of Rochdale Canal. In the compound yard two engine houses were situated and a basin connecting to the surrounding canal provided the transport routes for coal and cotton. The industry was continuously expanding and even in the middle of the 20th century the premises were refurbished with reinforced joists as the machinery grew heavier. The decline of the industrial area and Murray's mill began in the

1970's. The desolate and empty buildings gradually turned the east city blocks into unsafe areas⁴⁴.

In 1989 the complete Ancoats district was designated a conservation area and the ambitions for this post-industrial suburb were to offer residences, work places and commercial areas in existing or new buildings. The Ancoats Group⁴⁵ was founded in 1990 and later developed into a BPT with a professionally mixed board of trustees⁴⁶ and the beneficiaries were all inhabitants of Ancoats. The Ancoats BPT (ABPT) joined the partnership of Ancoats Urban Village Company in 1998⁴⁷ to promote the area, calculate conservation projects and exploit empty building plots. The ABPT received funding⁴⁸ but struggled with the different owners to manage a purchase of properties, and the prices were constantly increasing.

Finally the Northwest Development Agency, NWDA, stepped in and offered to contribute financially to the refurbishment⁴⁹ of the mill and in the end they bought the whole complex for one single pound⁵⁰. In 2004 the funding enabled the conservation works to begin with shell-repairs (C_s) of the mill planned by the first commissioned architect⁵¹ during three years⁵². Parallel to the construction works, the interior planning and building permit were designed by a second architect consultant⁵³ for the new adaptation of the mills for future residential use. The open Heritage day held in September every year enabled public admission to the mills and ABPT to recruit volunteers who were asked to write down the history of Ancoats⁵⁴ within the "Skills, Schools and stories" project funded by HLF. Here schools as well as the social welfare office were involved⁵⁵. Unfortunately the financial crisis put a stop to many preservation ventures in Ancoats during 2008 and Murray's Mills have also been left as empty shells in the area⁵⁶. Murray's Mills is a privately funded project⁵⁷.

7.5 The use of Economizing funding in the case studies

In order to distinguish if the funding has been economized in the planning of the projects described above, the potential effects have here been analysed concerning; intentional distributions of the building phases for value advocacy and how the vertical archaeology has been promoted for enabling incomes.

7.5.1 Economizing planning (C_{SA}) St. Jakobi

In the conservation project of Saint Jakobi church the building phases were intentionally distributed in order of priority so the church could remain acces-

sible to the public during the whole time of construction. The Shell-repairs (C_s) during the first ten years were sectioned according to how funding was made available, for the many safety measures needed on brickwork, roof truss or lead windows. The preservation of the main altar and the organ front still remains and this proves that finance was intentionally distributed so that the building could remain in use. Meanwhile the funding was spent on the most urgent protection work needed, in order of priority. Other mobile sacred items, which had been stored in the church since 1945, were re-arranged as a permanent interior exhibition. Such public accessibility did strengthen the general awareness of the project adaptation (C_A) as it did the recognition of the church⁵⁸. This was imperative due to the existing negative or indifferent attitude to Jacobi at the project outset, since the church had been used as a mechanical workshop for more than 50 years⁵⁹.

The decision of the future utilization as a cultural building was launched early on and remained unchanged and this was most likely crucial for pulling the long-lasting venture forward. This concrete goal, for example enabled individual citizens to get involved (EA) in the new *Förderverein* or advocacy group⁶⁰ which offered a channel for even small private funding (FA) contributions. An association was later established⁶¹ and since 2003 has been organizer of all cultural activities in Jacobi. The early public use for temporary exhibitions, concerts and the purchase of literature on the church⁶² also brought in a modest income (FA). However the most essential factor has been the marketing of the Culture church; *Kulturkirche St. Jakobi*, and this is verified by the social significance it constitutes today for the city of Stralsund⁶³. The conservation practice of St. Jakobi can be arithmetically expressed as follows:

The template of the finance model

$$(F + V_A) - C = V_B$$

F = Finance/investment from financier

V_A = value activating to funding (A+VP)

C = cost conservation

V_B = marginal value

The "restructured" finance model of the St. Jakobi project

$$(F + V_A) - C_{SA} = V_B$$

F = Direct funding (DF) from private financier

Transmitted funding (TF)

Replacement funding (RF)

$V_A = (A+VP) EA/FA + H_3/UNS$

$C_{SA} =$ cost conservation; shell-repair (C_s) and adaptation (C_A)

C_s -----EA/FA-----H1/H3

C_A -----FA-----U/N

V_B = marginal value

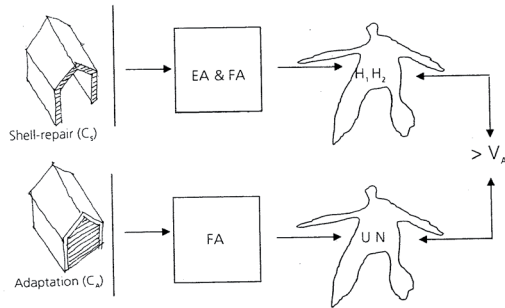

Figure 751.1 The intentional distribution of the building phases for St. Jakobi graphically presented.

Economize heritage funding								
Assumed funding models				Financiers				
Conservation projects.....	Order	Size	V. archaeology	Accelerators	VP	Private	Public	Alternative
Jacobi	CSA	Yes	Yes	EA & FA	H, H, UN	F/NPO/AG	P/A	FM/L/D

Table 751.2. The intentional distribution of the building phases in St. Jakobi had the capacity to induce all of the financier groups.

7.5.2 Economizing planning ($C_{(SP)}$) Rossewitz palace

The building phases or stages in the Rossewitz palace conservation were disrupted and for this reason never managed to become distributed intentionally i.e. re-prioritized, although there was an initial attempt for years to give public access to the site⁶⁴. As the shell-repairs (C_s) began it was still impossible to comprehend or foresee the extent of the vast security measures which were to be needed since the palace interior was totally covered with layers of collapsed construction of wood, plaster and brickwork. The clearance then revealed the hard facts and so stabilising measures had to begin with work on the pile dwellings, columns and vaulting in the basement since these had been severely damaged, when the foundation of wooden poles had partly lost their load bearing capacity, since the moat was drained in the 1950^s⁶⁵. Continuous constructional safety measures were carried out as funding became available, but due to exceeding costs the palace still remained uncompleted. The discouraging appearance of the deteriorating facades has most likely been a hindrance for laymen ever to believe that this venture could have any future prospects.

The change in ownership after 2004 definitively cut off the link to the local private group which once induced and campaigned for the restoration works and

with that the enticements for providing the future adaptations seemed to have vanished. The new proprietor focuses only on the preservation (C_p) of the illusionistic fresco paintings, which might be due to the fact that these still qualify for external funding. However, when even the ambition to support funding for a future utilization and adaptation of the palace as a whole fails, only a chosen few will be able to admire the preserved frescos.

The early ambitions to give the local community access to Rossewitz at every occasion, by organizing concerts or other cultural gatherings, gave the monument a new significance (EA). For a time the reputation in local parlance of the palace as a *haunted house* or as having undesirable *feudal castle* attributes, was positively undermined, but under the present conditions this may not be for long. The naming stones, brochures and facsimile reprints enabled all groups to make a financial contribution and reaped minor project profits, but primarily it gave Rossewitz the publicity the palace so desperately needed. Local conservators, students in conservation and craftsmen were at first also able to improve their building conservation skills through the Rossewitz project, but these were then replaced by experts on mural paintings. The conservation practice of Rossewitz palace can be arithmetically expressed as follows:

The "restructured" finance model of the Rossewitz

$$F + V_A - C_{(S)P} = V_B$$

F = Direct funding from public (private) financier

Transmitted funding

Replacement funding

$$V_A = (A + VP) EA / FA + H_3 / UNS$$

$C_{(S)P}$ = cost conservation; shell-repair (incomplete) (C_s), preservation (C_p)

$$C_s \text{ ----- } EA / (FA) \text{ ----- } H_1 / (H_3)$$

$$C_p \text{ ----- } EA \text{ ----- } H_2$$

V_B = marginal value

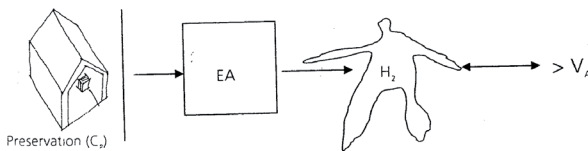

Figure 752.1. The intentional distribution of the building phases for Rossewitz palace graphically presented.

Economize heritage funding									
Assumed funding models						Financiers			
Conservation project.....	Order	Size	V. archaeology	Accelerators	VP	Private	Public	Alternative	
Jacobi	CSA	Yes	Yes	EA & FA	H, H ₃ UN	F/NPO/AG	P/A	FM/L/D	
Roszewitz	CP	Yes	Yes	EA	H,	F/AG	A	D	

Table 752.2. The intentional distribution of the building phases in Roszewitz palace project induced only a few of the financier groups.

7.5.3 Economizing planning (C_s) Murray's Mills

Management of the building phases in the Murray's Mills conservation was actually distributed intentionally, but not however with the aim of economizing funding for the Mill conservation, since the Northwest Development Agency (NWDA) was the major financier⁶⁶. Their aim was to increase the monetary value of all additional empty building plots and other holdings in the area. Allowing public access to the industrial legacy was never NWDA's intention. This has been the goal of the former owner; the ABPT, who had first initiated the conservation project, just as it was the authorities and the Heritage Lottery Fund's objective which they had been administrating. NWDA's prime target was to replace the run-down and un-safe character of the neighbourhood of Anscot with new refurbished facades, and to promote a nominal value growth (FA) for the whole district.

The shell-repair (C_s) which was carried out, concerned the strengthening of the load bearing constructions⁶⁷, repairing damages caused by weathering and improving the interior comfort by improving insulation⁶⁸. The originally fire protective construction of secured floor joist⁶⁹ and staircases could nevertheless remain intact. The only issue of concern was to secure the pile dwelling construction⁷⁰ as the mills were founded on layers of clay. The interior planning and its building permit are completed, but work has still not begun. All conservation works carried out, were supervised by industrial archaeologists and the professional experience from the Murray's Mills conservation were eventually published in a book (EA). The funding earmarked for encouraging the project in the community "Skills, Schools and Stories" integrated the mill project socially and across generations and resulted in a Web publication as well describing the social life of the Ancoats (EA). The conservation practice of *Murray's Mills* can be arithmetically expressed as follows:

The "restructured" finance model of the Murray's Mills

$$F + V_A - C_S = V_B$$

F = Direct funding from private financier (NWDA)

(Transmitted funding, BPT)

(Replacement funding, BPT)

$$V_A = (A+VP)EA/FA + H_3UN_3$$

C_S = cost conservation; shell-repair (C_S)

$$C_S \text{ ----- } EA/FA \text{ ----- } H_1/H_3$$

V_B = marginal value

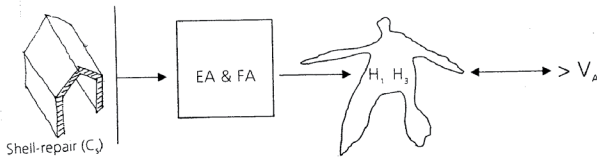

Figure 753.1 The intentional distribution of the building phases for Murray's Mills graphically presented.

Economize heritage funding								
Assumed funding models						Financiers		
Conservation project.....	Order	Size	V. archaeology	Accelerators	VP	Private	Public	Alternative
Jacobi	CSA	Yes	Yes	EA & FA	H ₁ , H ₂ UN	F/NPO/AG	P/A	FM/L/D
Rossewitz	CP	Yes	Yes	EA	H ₂	F/AG	A	D
Murray's Mills	CS	No	No	EA & FA	H ₁ H ₃	F/NGO/AG	P/A	FM/L

Table 753.2 The intentional distribution of the building phases in Murray's Mills project could, in spite of its limitations, induce a majority of the financier groups.

To conclude the findings table 753.2 reveals that an intentional planning of size and building phase priority order was utilized in the building conservation projects to economise funding, but individually so, to various degrees, and expressed as; order, size and income (V_A ; vertical archeology). Projects which might be the most efficient for inducing both accelerators (EA/ FA) were those including the two building phases of sell-repair and adaptation (C_{SA}), as the St. Jacobi exemplified. However, shell-repair (C_S) alone was sufficient to stimulate these accelerators in the Mill project, since only the external settings of the mill site were required for the main purpose of establishing the new hoped-for image of the post-industrial Ancoats area. This approach of only promoting the front façade is often more accepted for industrial heritage. For obvious reasons this has more of an anonymous character, which is why its appreciation refers to the external settings alone. The interior will always be replaced when the industrial legacy is refurbished and the Mill project reveals an excellent example of how the mix of financiers' value preferences actually rendered the Ancoats' venture possible.

The unfinished shell-repair and preservation phases; $C_{(SR)}$ of the Rossewitz conservation, diminished its capacity to stimulate more than the failing emotional accelerators. The funding adequacy for completion which was needed -, either future building adaptation or by the building succeeding in generating some sort of income – is due to the lack of inducement for the financial accelerators, though this was initially present in the 1990's. The situation is unlikely to change since the site today excludes public access, other than occasionally. In fact the facade funding predicament could have been solved by an historical easement, but credit funding is not applied in Germany.

7.6 The use of Assuring funding in the case studies

Finance models can only claim to be sustainable if the future gain is guaranteed in built heritage, subsequent to the conservations, in view of all the efforts made. This involves the physical conditions, just as does its future capacity to encourage funding. All protective measures have to be compatible with the original structures to decrease the risk of future damages and the conserved built environment must still uphold the ability to nourish the mechanisms of funding, by promoting the emotional (EA) and financial (FA) accelerators for a revolving backing.

7.6.1 Assuring future gain (V_B) of St. Jakobi

The objectives for all protective measures in the church were that all new construction safety measures had to be compatible with the originals⁷¹. The quality has also been checked by the scientific committee, or *Wissenschaftliche Fachbeirat*, which was set up by the private financier (DSD) and enabled a variety of professionals⁷² to be involved in the progress of the conservation works. The *future gain* from the St. Jakobi's building's physical and technical point of view is for this reason secured.

The Kulturkirche St. Jakobi is today an established social and cultural institution in the city which ensures that the emotional as well as the financial accelerators are at work, essential to nourish the building's future funding and for that funding to revolve. The strong heritage funding by the parties like the DSD foundations has changed, such parties are not as capable of funding as they used to be, during the 1990's. For this reason built heritage like Jacobi in the new states would require that credit funding be applied in Germany, either as historical easements, risk-free municipal bonds or portfolios with shares in combination with put options. The well recognized culture establishment of St. Jakobi, can most

likely bring about a positive finance value growth for future investors and $V_B > V_A$ be fulfilled, just as Stralsund today is prospering.

7.6.2 Assuring future gain (V_B) of Rossewiz palace

The conservation work had the ambition that all measures should be compatible with the originals in the project and the ambition was high⁷³. However this could not be realised at all times due to the complexity of damage in the palace caused by water penetration and absence of it when needed, which had severely damaged the wooden and masonry constructions. Out of the preserved interior, here represented only by the illusionistic mural painting, all measures taken have remained true to the original settings⁷⁴.

The emotional accelerators which solve the future revenues are much reduced in the project for a revolving funding and reinvestments are urgently called for in order to complete the shell-repairs on the facades and for an adaptation. Historically significant endeavours which leave little visible traces of maintenance at the site have less chances of future funding while $V_B > V_A$ today have more the character of $V_B < V_A$. Additional actions such as credit funding by easements or risk-free municipal bonds could have stimulated the financial accelerators of other financier groups, hence enabled the completion of the Rossewitz project.

7.6.3 Assuring future gain (V_B) of Murray's Mills

The shell-repair involved strengthening the load bearing constructions, to secure the pile dwellings due to the clay soil and to improve the interior comfort for residential use. In Murray's Mills project 95% still remains as original structures, since these were fire resistant to begin with.

Publications on the social life in the industrial area and the practical experiences attained from the conservation works will always encourage the emotional and the financial accelerators. However, the industrial suburb will most likely be more in focus than the mills in particular. Industrial heritage have less individualized character since it is mass produced, in contradiction to built legacy such as the St, Jakobi and Rossewitz Palace. The Murray's Mills preservation is nevertheless considered to have been the investment catalyst, or financial accelerator, for the whole Ancoats refurbishment venture and its actual value impact on the vicinity has now even been scientifically verified according to the ABPT⁷⁵. The current financial crisis may have slowed down the project progression but the future prospects for attaining finance for more industrial adaptations for office or residential use will most certainly materialise⁷⁶, as long as $V_B > V_A$ is fulfilled. The

investment by the NWDA was operating as an easement would have done, as the facade preservation also enhanced the respect, or value, of the whole neighbourhood and this verifies how strong the impact of the historical quantity value (H_3) is for all credit funding⁷⁷.

Assure heritage funding		
Assumed future gain of...	Compatible measures	marginal value
Jacobi conservation	Yes	$V_B > V_A$
Rossewitz conservation	Yes	$V_B < V_A$
Murrays's Mill conservation	Yes	$V_B > V_A$

Table 763.1 Future marginal value or future gain is secured in Jacobi and Murray's Mills since $V_B > V_A$ are fulfilled, alas today the contrary is the case for Rossewitz Palace $V_B < V_A$. Credit funding as easements could save the palace project, though as such it is not applied nationally and an easement-process actually took place in the Mills project.

The table 763.1 reveals that compatible constructions or materials were favoured in all projects; though some modern solutions were added to secure and adapt the construction. This may affect the future dividend if damages occur unless there is regular monitoring. The ability to attain revolving funding only was less in the case of Rossewitz since it is lacking the financial accelerator and the emotional one is weakened, stemming from the fact the palace now stands empty and only opens occasionally, on request.

7.7 Summary

The two final topics of the strategic finance plan; the economizing (C_{SAP}) and assuring (V_B) of funding, tested here, show that more can be done to establish a sustainable financial management in conservation practice at heritage sites. The mappings of the actual planned incidences from practice, of economizing and assuring funding, in three building conservations have been analysed; The St. Jakobi church, The Rossewitz palace and Murray's Mills.

7.7.1 Step 4 economizing funding

Distributed planning of the building phases, C_{SAP} in conservation practice involving size and order, may economize heritage funding when used for marketing. These most likely have distinct individual capacities such as the ability to function as actions of accelerators (FA/EA) matching values and prospectively

generating funding, (see table 72.4-1). Moreover the distribution can enable the generation of proceeds as long as the intrinsic assets; the vertical archaeology of time layers, are marketed, and as building sites become publicly accessible due to promoting the financial accelerators (FA).

The St. Jakobi project was distributed according to a deliberate plan which enabled financial and emotional accelerators to operate in its favour. The advocacy group and the foundation established during the project did enable the intrinsic assets of the St. Jakobi to be marketed and generate income. The conservation of Rossewitz palace initially was intentionally distributed because financial and emotional accelerators were then encouraged, and also due to the marketing of the heritage assets. The disruption caused by the change in ownership left the facades uncompleted, thereby reducing the financial accelerator. The new ownership only enhanced one value aspect, the historic knowledge value (H_2), which may jeopardize all other value increase achieved. However, as regards building a level of respect for the palace as a whole, unless the ambition of securing its future prospects returns. The shell-repair of Murray's Mill was consciously distributed but not for economizing funding, as the owners investment was to create a proper street landscape of preserved facades, activating the incentives for value growth of the whole Ancoats area. This in turn enabled price increase for the empty plots and buildings and the financial accelerators. Other groups increased the significance and emotional accelerators of the mills using the technical as well as social impact from cooperative programs. The outcome finally was published in printing and made available on the Internet, hence generating an income.

A summary of the findings revealed that the planning of the St. Jacobi preservation was distributed or re-allocated to economize funding by inducing emotional and financial accelerators to value growth and income. The Murray's Mills project was distributed only to involve the shell-repair with the exterior facades inducing value growth for the city block. Common to the two projects was the distinct goal for the buildings' future use⁷⁸, the large number of actors involved, the stable bottom-up grassroots structure and that both projects were privately funded. The conservation of Rossewitz initially planned the distribution of building phases to reduce costs, employ accelerators for income and engaged a local advocacy group. The disruption, when transferring the ownership, cut off the community and grassroots from the palace, which could explain why the facades still remain unfinished. In contradiction to the Jacobi and Mills, the future utilization of the palace was never settled, the number of actors involved was less, which means the conservation was severely effected by the reduction⁷⁹ and the palace was publicly funded. The study shows that restructuring of the building conservation practice; intentional distributions, most likely can reduce costs and economize funding.

7.7.2 Step 5 Assuring funding

Dividend refers to an expected positive marginal value (V_B) vital for advancement and present in the preserved heritage. The *value activating funding* (V_A) is required for a finance support to commence. The final outcome of building conservations, thus likewise has to offer all built heritage new values which advances the ones which initially were assessed, to justify the spending made so that; $V_B > V_A$. A sustainably managed finance model needs to guarantee that the future prospects are ensured in the physical structures of monuments, since replacement of original constructions or building materials, which are less empirically tested, may cause damage and involve losses (FA) by affecting the nominal value; therefore this is to be avoided if one is to ensure the dividend. Preserved buildings must also always offer the emotional (EA) and financial (FA) accelerators needed for nourishing the mechanisms of a revolving funding.

To ensure the dividend all safety measures in St. Jakobi were made compatible with the originals so marginal value was secured physically, though the adaptation brought modern additions. Emotional and financial accelerators were established by the social and cultural institutions of St. Jakobi, which nourish funding so it will revolve. The complexity of damages at Rossewitz involved some modern constructional safety measures, but the mural paintings were restored compatible with the original. Only a weak emotional accelerator is today available for revolving funding for the palace. If easements or other credit funding had been applied this could have completed the project. The minor damage to Murray's Mills and the genuine fire safety capacity, limited the constructional measures since only minor structural modernizations had to be made. Both emotional and financial accelerators are available for revolving the funding when the investment market improves.

To conclude the findings- only Rossewitz palace has a reduced capacity for attaining a future revolving funding today, due to weak accelerator capacity for value. The uncompleted conservations in St. Jakobi can commence when finance is available, due to the strong accelerators, just like the interior adaptation of Murray's Mills and the other industrial "screens" of Ancoats. Concerning the physical conditions, primarily compatible materials have been used in the projects, though some modern additions been employed which demand regular monitoring, in order to prevent damage, if one is to achieve a future gain, for assuring the marginal value and financial sustainability.

Notes chapter 7

1. To achieve *economizing* (C_{SAP}) of funding by an intentional distribution of the building phases in conservations, each of which generates separate costs.
2. The *assuring* (V_B) of heritage funding covers the way in which the conserved built heritage can guarantee that a positive marginal value will be confirmed.
3. Despite the various climate conditions, cultures and lifestyles which exist globally, the problems with decay of building materials still make the building conservation work comparable. This is due to the fact that the selection of building materials in the past was limited. Christianization, imperialism and migrations helped to export the skill of building and architecture trends over the centuries. This development has standardized the built legacy, which we are to preserve. Wood, brick, adobe, lime and natural stone were most commonly used for construction works until the mid 20th century. Exceptions do exist, such as early concrete constructions such as the aqueducts by the Romans 100 BC and early 1900th century constructions for lighthouses and harbour constructions, resilient for under water conditions.
4. For instance costs increase which were linked to higher costs to manage temporary accommodation for residents. In Eastern European building conservation especially was a major problem during the 1990's, since many families often resided in one family homes.
5. The prestigious conservation of the Chinese Pavilion at Drottningholm in Sweden, which had qualified for the Heritage List. In this conservation project the craftsmen had to use around 30 000 razorblades in order to clean the plasterworks from the facades, see Hidemark (1998, p. 35).
6. Each building phase can be said to comprise six work stages; preparation, initial investigation I; archive, initial investigation II; building, planning (inquiry/ purchase), building site and documentation, see Skarin Pålsson (2001, p. 30). For new construction they can be said to include only four; Preparation, planning (inquiry/ purchase), building site and documentation.
7. These so called actions settled as well the outcomes in the Maglarp-Allhelgona cases.
8. This effect could be observed in the filed survey during Study 1, especially in East Germany. The value resurrection for built heritage, based on historical ties was essential for the funding to begin.
9. The actual extent of damages and its conservation costs.
10. Other than when it comes to heritage at risk.
11. See studies by the National Trust or the effect of easements.
12. See chapter 3.
13. *"It is almost impossible to get funding for shell-repair of roofs, since people or financiers want to see obvious result of their aid"*, quotation from Zülch (2009, interview).
14. To limit the extent of conservation works and maintenance costs for roofs, a thorough inventory of their actual conditions is fundamental.
15. The intense air raids of Dresden by the allied troops in 1945 wiped out 15 km² of the city area and thus demolished the Frauen Kirche. The church was preserved as a ruin or memento of the devastating city destruction in the 1950s, Frauen Kirche (2009, Web).
16. The traditional building construction methods, which were based on empirically tested material and craftsmanship, were the most commonly used ones one until the 1950's in Sweden.
17. A new conference centre for SYSAW, see chapter 3.
18. All building materials behave in different ways when exposed to moisture, when it comes to expansion due to their individual humidity transport capacity. This effects not least the salt crystallizations, which is one of many causes to damage.
19. To match wider value inclusive spectra, the H₃UNS concept was designed as a standard template for analyzing the mechanisms of funding.

20. The emotional and financial accelerators to re-establish temporary concealed values in built heritage for man.
21. The Jakobi Church and The Rossewitz palace were investigated on site as early as during Study 1, but the Murray's Mills analysis is primarily based on interviews with the involved participants, during 2009.
22. See Skarin Pålsson (2001, p. 128).
23. *Die Wende* in German.
24. Zülch (2009, interview).
25. Kirmitz (2009, Interview).
26. The installation of the sprinkler system and the fire safety zoning, *ibid* (2009, Interview).
27. The Jacobi was privately funded since 50% came from the foundation as direct funding and additionally advocacy groups have been contributing with replacement and transmitted funding, see Skarin Pålsson (2001, p. 133).
28. See *ibid* (2001, p. 113).
29. The stronghold of Roosenytze was demolished during the 30th war, *Ibid* (2001, p. 113f).
30. Friedrich Franz I, *ibid* (2001, p. 113f).
31. The park was used for agriculture and the refugees were Germans who had fled the eastern provinces which were Polish territory after the second 2nd World War, *ibid* (2001, p. 113f).
32. "Rote" Rosie Volkmann, *ibid* (2001, p. 113f).
33. Ideological idiom for a feudal palace.
34. The casual labour that came was either voluntary workers or temporary unemployed groups, so called ABM workers, *ibid* (2001, p. 113ff).
35. Construction safety measures caused by incessant water penetration, *ibid* (2001, p. 113f).
36. The architect became ill and had to close down his office in 2002, Böhnke (2009, interview).
37. *Ibid* (2009, interview). During the 1990's architect Böhnke and volunteer groups were promoting Rossewitz in all sorts of ways; concerts, lectures and through publications. The change in ownership of today has cut off the palace from the community since Rossewitz is closed to the public. However, on request the palace can be showed for private groups on some occasions during the summer, Freiheit (2009, interview).
38. The mural painting at Rossewitz could have inspired the German born architect Nicodemus Tessin senior in the 18th century, when designing the mural paintings in his private palace in Stockholm. This house was however demolished by 1899. The Tessins; father and son, were architects for the Swedish Royal castle in the 1750s. The architect's family was most likely originally from the village of *Tessin*, which is situated in the region of Rossewitz. One additional proof that Tessin was inspired by Dieussart is that his "Theatrum Architecturae" was in Tessin's own library, see Skarin Pålsson (2001, p. 120).
39. See see Skarin Pålsson (2001, p. 115f).
40. It was a technically advanced heating system based on a hot air transport system through tile ovens, like *kaloriferers*, *ibid* (2001, p. 113f).
41. The future plans for the manor house in the 1990's was that it should be used as a cultural building for exhibitions, concerts and artistic activities, *Ibid* (2001, p. 113f).
42. More than 50% was allocated as direct public funding from state; that is 75% of the total expenses, *ibid* (2001, p. 113f). At first, replacement funding was allocated by the local community as well.
43. Facts about the Murray's Mill project have been attained through interviews with Dickson, Brenam and Moth during 2009.
44. Dickson (2009, interview) and Murray's Mill (2009, Web).
45. A group of historians with the ambition to preserve the area, Dickson (2009, interview).
46. BPT; a Building Preservation Trust, sponsored by Heritage Lottery Fund. The participants in the trusts were lawyers, urban planners, architects and solicitors. A trust has tax-

- exemption privileges for trading or reinvesting profits in historic buildings on a non-profitable basis, Dickson (2009, interview).
47. The movement was part of and inspired by the *Renewal Urban Villages*, support by Prince Charles, *ibid* (2009, interview).
 48. The Commonwealth Games were held in Manchester in 2002 and this fact most likely helped to put focus on the suburb as well. As a result funding was granted from Heritage Lottery Fund (HLF) and English Heritage. The requirements were however that the Ancoats Building Preservation Trust would buy and preserve St. Peters Church in Ancoats as well. This church had been standing abandoned for 40 years, *ibid* (2009, interview).
 49. The HLF granted the project 8 million GBP and Northwest Development Agency paid for the rest, Moth (2009, interview).
 50. *Ibid* (2009, interview).
 51. The BDP is short for Building Design Partnership, in Manchester. “*We assisted the trust with the second funding application in 1999, after their first one has been rejected. This one was approved and our office was in charge of the shell-repair on Murray’s Mills, quotation from*”, Moth (2009, interview).
 52. The shell-repairs were completed in 2007, *Ibid* (2009, interview).
 53. The Richard Murphy Architects in Edinburgh, 2004-2007. “*The final goal with the project was indistinct and constantly changing. One competent architect had previously been responsible for the shell-repairs and he was involved in the project early on. This time we came in late and only for assisting with the building permit of the refurbishment planning. A more coordinated process would have been much better*”, quotation from Brenam (2009, interview).
 54. Through archives studies and interviews with previous citizens, Dickson (2009, interview).
 55. Unemployed and ex-convicts were engaged in the early construction works, *ibid* (2009, interview).
 56. *Ibid* (2009, interview).
 57. More than 50% (>90% most likely) of the direct funding came from the investment company NWDA, Heritage Lottery Fund, but as replacement funding of voluntary work as well, see note 49.
 58. “*So that people would see that something was going on*”, quotation from Zülch (2009, interview).
 59. An assembly hall in the towers and its exterior for public parking, see Skarin Pålsson (2001, p. 128).
 60. Förderverein St. Jakobi Kirche zur Stralsund was established in 1995.
 61. Diakonisches Werk, was founded in 1996.
 62. Between 1945 and 1990 only a few conservation projects were initiated outside Poland (PKZ see page 43) due to lack of public funding and building materials. This was why building archaeology was instead far more practiced. When the restoration projects began after 1990, the historic buildings regained respect and significance in cities like Stralsund.
 63. “*The Kulturkirche St. Jakobi has been most essential for our city*”, quotation from Kirmitz (2009, interview). The city of Stralsund has a tradition of refurbishing sacred buildings. The Ocean museum, Meeres Museum from the 1950’s was set up in the 13th century St. Katharine Monastery. An affluence of medieval architecture in the city explains this radical re-use of historic building. Merely within the city walls of Stralsund they have over 800 listed historical landmarks and a population of 60 000.
 64. The Rossewitz’s surroundings do not permit unplanned visits since it is in the countryside, but accessible by car since it is close to the Rostock-Berlin highway.
 65. The park had been used for agriculture after 1945 which is why the moat had been drained. This led to oxygen exposure of the wooden poles in the manor’s foundation and made them decompose, since they began to rot.
 66. The HLF granted 8 million GBP and the NWDA stood for the rest, Moth (2009, interview). This should approximately have been somewhere between 12-16 million GBP.

67. The floor joists were properly attached to the brick walls, Moth (2009, interview).
68. Roofs were insulated and the windows were replaced. The staircases were all made out of brickwork, steel or stone, *ibid* (2009, interview).
69. The wooden floor joists were “sealed” with lime mortar and totally covered with metal sheets. Still 95% of the original structures still remain today, *ibid* (2009, interview).
70. We had to establish a broader base in order to spread the vertical loads, *ibid* (2009, interview).
71. Lime mortar for the brickwork and the concrete tiles were replaced by new ones out of ceramic for example. This was all registered in Study 1, during visits to the building site 1996-1997.
72. Financiers, authorities, church representatives, engineers, conservators, curators and architects, see Skarin Pålsson (2001, p. 128f).
73. The architect was very committed to the Rossewitz restoration which enabled him, for the first time ever, to set up his own private architectural office. In cooperation with other local consultant firms, he had been engaged in the protection of the manor house, even on voluntary basis, ever since the 1980’s. See note 37.
74. The elaborate conservation work is due to the fact that the mural fresco paintings have clay plaster grounding and for this reason their condition depends immensely on a humidity climate which is constant.
75. Dickson (2009, Interview).
76. A far more intricate matter is to see what the potential prospects will be for the conserved St. Peters Church and this is why an adaptation for a new use has to be developed. The church was owned by a private company, which had been denied permission to re-cycle the church building for a residential use, due to its Grade II* status. When English Heritage was granted funds for the Mills project the deal was that the trust should conserve St. Peters Church as well and again resell it, but the church is still un-used, *ibid* (2009, Interview).
77. See easements NLC chapter 4.
78. Requirements set up by private financier; Nützungskonzept (Concept of future use).
79. The negative effect came when the architect, and key driver, became ill and had to resign from the project.

8. A Finance model for the built cultural heritage

Summary, discussion and final conclusions

8.1 Introduction

This chapter begins by summarising all discussions and findings of the inquiry in previous chapters by answering the research questions initially posed. Based on these outcomes a new heritage finance model is presented, however, these results also require further clarification. This is why the second part of the chapter scrutinizes additional real-life cases with the intention of explaining the essence and impact of emotional and financial accelerators, identified in this study. Recommendations are made on measures to take for augmenting heritage funding in general, and for Sweden in particular, to balance the current finance shortfall in heritage economics. The chapter ends by outlining a potential future research field and proposing how the heritage finance model could be useful for developing economies.

8.2 The topics of inquiry –to bridge heritage economics

The topics of inquiry of this doctoral thesis involved analysing how to deal with the deficiency in heritage economics and hence to bridge the gap between needs in the heritage sector and fiscal reality. The answer and aim has thus been to propose a new management device to enhancing the fiscal resources for built cultural heritage; the heritage finance model. The assignment involved introducing new terminology into building preservation instigated by the idiom of economics. This approach required identification of incentives spurring present financiers and the capacity among them; it entailed initiating new capital groups and proposing measures for cost reduction as funding assurance. The overall quandary involved one main research question: *How could an economically sustainable finance model be structured to meet the challenge called forth by the expanding built*

heritage sector? Limitation on the acquiring, economizing and assuring of heritage funding, subdivided the approach into four issues of concern which decided the structure of this investigation, involving: *What are the inducements for heritage funding? What characterize the present private finance sources of cultural heritage? What characterize the present public finance sources of cultural heritage? What alternative funding groups may be encouraged to heritage support? Can building conservation practice be redistributed to reduce costs?*

Strategy and research design of this inquiry involves five steps. During the first; *analysing heritage economics in practice*, all basic data were attained by empirical field observations completed in 2000 and 2004. The methods applied, the survey outcomes, and the further analyses in 2008, have already been presented in chapter 2 and appendix 1. As the second step, a template from economy was refined, *to assume a value stabilizing heritage finance model*, since viable prototypes are missing. The third, fourth and fifth step involved analyses of *acquiring, economizing* and *assuring* of funding.

8.3 Step 1; analysing heritage economics in practice

8.3.1 Problems and solutions on deficiency of heritage funding

Today's deficiency of heritage funding is due to the fact that there have never been as many registered, irreplaceable, built cultural heritage sites worldwide. Our affluence of cultural assets can as yet only be guaranteed on condition they receive regular maintenance and for this reason adequate funding is required. Future circumstances indicate conditions which alas predict a cost increase in this area and a risk that the growing finance deficit may encourage rash as well as irreversible decisions is thus imminent¹. The new economic role of built cultural heritage as assets, by the UN World Commission², and its widened definition, explains the increase in the number of sites. Affluence in cultural properties makes maintenance costs rise and illustrates the present funding deficit, which unfortunately is increasing. For this reason the prospects of influencing funding acquisition, economizing and assuring have been studied in this dissertation, within the framework of an intellectual, but operational, management device; -the heritage finance model.

Solutions to tackle finance insufficiency of funding for built heritage nationally have been applied over time, with measures as follows; to demolish building heritage sites, to establish new finances for a few, or to reduce costs. Demolition of built heritage implies that unquestionable guidelines, or value norms, exist

which are agreed upon by all in society for eternity. This is to make sure of selecting the less significant properties for removal, from the more valuable ones. History confirms that using demolition as an answer for solving funding deficit is inapt, since this solution is irreversible and thus heritage destructions are likely to be regarded with disdain in the future³. Demolition is also incompatible with regards to today's environmental policy on energy-saving and on pecuniary waste, while the loss of the building itself means a potential income resource goes to waste. One last issue to consider is having the foresight to see what might happen next in each case, after demolition. The vacant plots will most likely be replaced by new constructions and since architecture has never had such a globalized expression as today, these will automatically be less founded in the existing cultural context. On the contrary, by promoting heritage recycling; re-use or partial or complete adaptation of building sites, as used to be employed throughout history, this may prevent historical city centres from adopting a far too uniform appearance in the future. New adaptations, for instance of a former biscuit factory like Fulton Market in New York, may have shortcomings, but still allow the diversity of a city's origins to show. What once has shaped a city is the result of its individualized past.

To enhance new finances for built heritage, in former times used to imply more man-hours, as building materials were primarily locally produced. The church also financed it using revenues gained from selling letters of indulgence or by collecting money from its parishioners. Industrialisation allowed the spreading of wealth in society to new social groups and to companies, rich from trade or industrial productions. The new-found industrial wealth was most likely one of the major explanations for the style purification movement evolving in Europe, with the scientifically grounded restoration of the Cologne Cathedral as prototype⁴. Protests, against the resulting altogether too sparkling and polished restored monuments most likely encouraged the establishment of public bodies – the national heritage boards. This centralization of heritage management in a sense also shut the door to private investors supporting building conservation altogether.

Former times in fact show that private funding was the most commonly used historically, with a variety of payment types; from man-hours, building materials to donations. Public funding became first firmly established when the public bodies of heritage authorities were set up around the year 1900. In nations affected by the two world wars, new and alternative funding solutions had to be developed since they were heavily dependent on voluntary labour, capital and a commitment from the private sector. Other nations like Sweden, unaffected by wars, never had to encourage private initiatives. However, recent case studies evaluating heritage funding from practice in conservation projects (Skarin. Pålsson

2001) revealed noteworthy hypotheses on likely unique effects for work processes by the two major funding sources; public and private. These conjectures verified later on (Skarin, Pålsson 2004) that public funding may cause undesirable limitations, an issue to consider in policy decisions.

To reduce costs by setting up fixed price estimations for preservation works is difficult since complex and initially hidden damages can always emerge unexpectedly in the existing built fabric. This fact, and often changing objectives among the many professional groups involved, can lead to costly reconsideration. Yet, building conservation comprises diverse work phases, which refer to individual items of expenditure. The economizing proposition of how to solve fiscal deficiency in the heritage sector could perhaps be linked to the practical conservation works by adjusting the building phase distributions to improve the recognition of the built heritage and resourcefully regulate the building measures in accordance with the funding available.

8.3.2 Actions, proof of the adjustable value and key for funding

Statistics might indicate that the quantity of built cultural heritage is the highest ever, but bear in mind that this refers only to its appreciation. The physical buildings have been around the whole time, but interpretations of their intellectual values have grown. What society considers as a valuable cultural heritage is not absolute but directed by what the spirit of the age regards as irreplaceable buildings. The New Maglarp case for instance revealed how society's perception can change- a feeling of reverence for a prestigious temple manifesting future optimism of growing wealth in society, and suddenly undergo a complete transformation. In a span of less than a century that perception was replaced by distaste for the church as a boastful showpiece instead. In 2007, the church was demolished, despite being legally protected. Only two years earlier the Allhelgona church had been inaugurated as a museum and a re-discovered new appreciation of the building had turned this church into a valued recourse, generating further investments. These value fluctuations described, settled their outcomes or fate, by inducing a sense of willingness to support the projects financially. The fact that the churches described actually had several uniting features, even as regards their technical conditions; does imply that values are not necessary linked to, or refer to, the heritages' static physical structures. More likely the value assessment of built heritage is influenced by how the external conditions, or *actions*, depict the legacy and how this becomes perceived by society. This perception or image is consequently possible to adjust.

Highly valued historic buildings are better qualified for funding investments than the ones lowly regarded. The actions, external conditions in the contex-

tual setting of built heritage, appear hence to depict the heritage different from time to time. The value assessment is therefore referring to how the buildings are perceived by man and not to their unalterable physical structures, which is why all value units can be said to be present in the buildings incessantly, though concealed at times. The changing level of respect with which the legacy is viewed, thus should be possible to re-establish when the right circumstances arise. Value awareness hence is modifiable and this implied that the capacity to enhance heritage funding artificially too could most likely be possible.

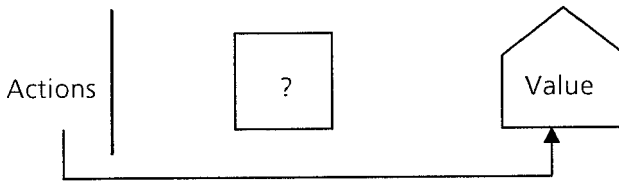

Figure 8.3.2.1 Value assessment of built cultural heritage is influenced by how external conditions, actions, depict the legacy and how this becomes perceived by society.

8.4 Step 2; assuming a value stabilizing heritage finance model

To acquire more funding as well as assure future supply, first of all involved scrutinizing the mechanism behind the present funding; its inducements, which entailed how to define value and its external enticement potentials. Secondly characteristics of today's different financial sources had to be explored and finally what alternative funding groups could have potential to resolve the dilemma of future heritage economics. To begin with the framework of an intellectual, but operational, management device; – the heritage finance model, had to be created, but prototypes for recovering funding management in building conservation were lacking.

Demolition of historic buildings was excluded as a feasible option for the model since reduction of sites will always be an irreversible time-specific act and an inconsistent waste of energy as well as money. For this reason primary areas of the model proposed hence involved funding acquisition, economizing and assuring. Identifying these areas of foci has settled the structure of this study and their relation was initially expressed as follows;

A finance model must ensure that finance can be acquired, economized and assured for the built cultural heritage (recipient).

While the finance model is referring to a process, the logical flow beyond the expressions had to be set in such a way so as to be made operational. This was possible by refining a basic finance model which is applied within economics and used for calculating liable profits from assumed costs and sales $S-C=P^5$. Inaccuracy in the variable expression, in the first attempt of the variable expression refinement, clarified that the heritage finance model in fact had to entail two value units; V_A , which activate funding and V_B , the estimated future gain, called marginal value.

The heritage finance model is expressed;
 $(F+ V_A) -C = V_B$

- F= finance from financier
- V_A = value activating funding
- C= conservation cost
- V_B = marginal value

An operational finance model must ensure that finance (F) can be acquired (V_A), economized (C) and assured (V_B) for the built cultural heritage (recipient).

8.5 Step 3; acquiring funding

8.5.1 What are the inducements for heritage funding?

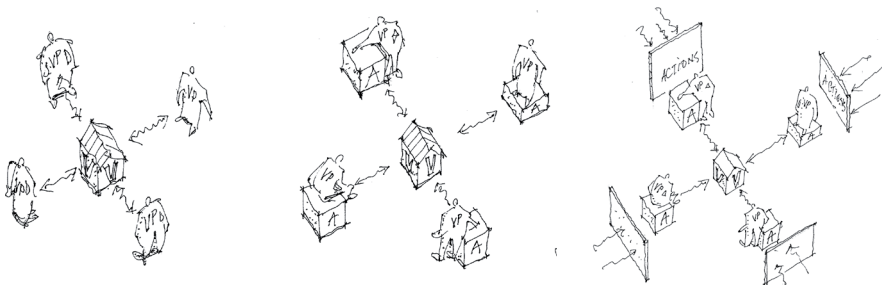

Figure 851.1 The perception of value is individual, accelerator “assist” us to see our value preference (VP), what we relish, in built heritage and external actions stimulate us to act favourable for its protection, such as funding.

To investigate the acquisition of funding involved firstly establishing the mechanism of funding itself. Secondly these findings were employed in order to securitize the present as the potential future heritage financiers. The first phase entailed suggesting a value inclusive template, not in order to attain a perfect or ideal concept, but to establish agreeable value basics to be utilized when revealing distinctions in value preference (VP) among heritage financiers.

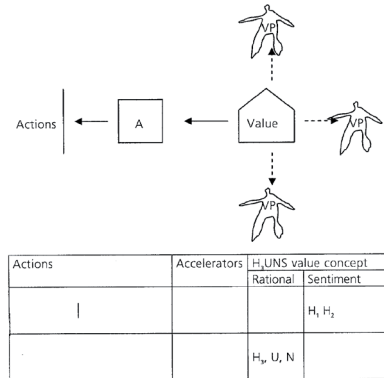

Figure 851.2 H₃UNS concept covers sentimental and rational value preference VP.

The H₃UNS concept was designed and tested for this purpose, but also improved comprising as far as possible a complete value inclusive spectrum for built heritage, (see figure 851.1). With this new index, linking accelerators and stimulating actions of the value units, could be revealed, which in turn encourage benefactors to carry out heritage funding. The value concept was rooted both in practice and theory⁶, thus this value concept index rendered the value dialogue possible.

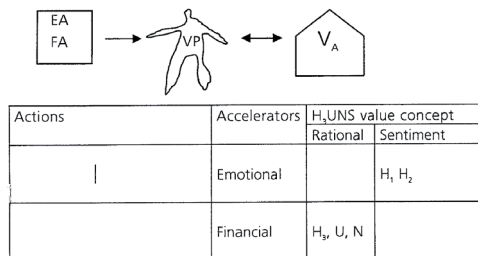

Figure 851.3 The H₃UNS value unit are linked either to emotional or financial accelerators. The H₃UNS concept is a value inclusive template or tool for distinguish the value preference (VP) of financiers, not an ideal concept, which might be unfeasible.

Secondly, in order to establish the funding acquisition, the financier's individual value preferences could be set according to the H₃UNS concept, using the systematization of facts via the OMAS format⁷. The format involved registering the Origin of the benefactors' funding, Methods used, their Accelerators of inducement and finally Sustainability of their funding. Origin of funding and methods could then jointly elucidate financiers funding commitment; their value preferences (VP). Once these individual inclination of values were identified then the linking accelerators (A) projecting them, when stimulated by actions, would in concert, disclose their mechanism of funding.

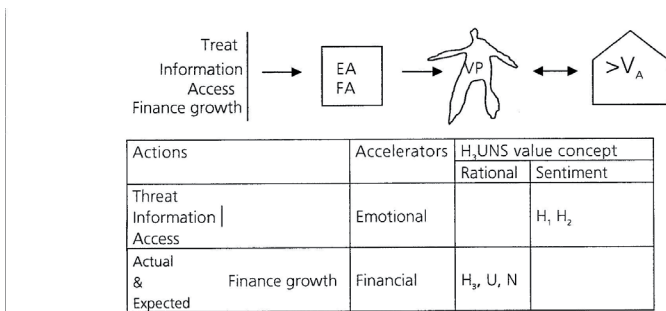

Figure 851.4 Based on the financier's own VP, either emotional or financial accelerators induce him, when stimulated by specific external actions, to perceive values in built cultural heritage.

The answer to; *What are the inducements for heritage funding?*- consequently will be as follows. Acquiring heritage funding involves that financiers' unique set of accelerators induces them, under the influence of external actions, to perceive their personal value preference in building heritage (VP= V_A). This thorough acquisition enhancement process (>V_A) here refers to the *mechanisms of funding*; actions- accelerators-values. Positive outcome of this process requires that actions, that are external conditions, depict built cultural heritage so it will become perceived via financiers' emotional or financial accelerators, for disclosing financiers' preferred, but temporary concealed values in building heritage. This awareness will in turn launch an economic behaviour among financier groups, which is favourable for the protection of buildings.

$$(F + V_A) - C = V_B$$

F= Finance/investment from financier

V_A= value activating funding (A+VP); accelerators (EA/FA) on H₃UNS concept, VP of financier

C= cost conservation

V_B = marginal value

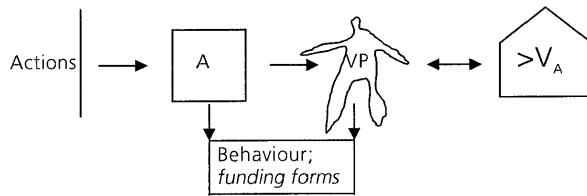

Figure 851.5 The mechanism of funding: actions- accelerator- value. The awareness that a financier's preferred, but temporary concealed values exist in a historic building, could launch an economic behaviour favourable for its protection.

8.5.2 What characterize the present funding sources of cultural heritage?

8.5.2.1 Financiers' investments; funding forms

The H₃UNS concept was the instrument or benchmark, which enabled analysis of the mechanisms of funding among private, public and alternative financier. Other than distinguishing their commitment for heritage funding, it was possible to establish the nature and capacity of their support, which here has been referred to as *funding forms*. While only a few financiers have solid capital for heritage funding, all additional forms of backing from groups proved to be as essential, since any support will enhance awareness of heritage value and thus ensure multi-diversity of built culture.

The five significant funding forms which were discussed and labelled in this inquiry were; direct funding (DF), replacement funding (RF), indirect funding (IF), credit funding (CF) and transmitted funding (TF). *Direct funding* is the most generally employed by all financiers. For the public body this involves capital, which is annually reserved in the budget in ready money for subsidizing heritage protections⁸, after granting approval of the relevant funding applications from private or public owners of historic heritage⁹. Private financiers also use the direct funding form. In times of financial recession the monetary capital may turn into manpower as *replacement funding* and can be set up in programs¹⁰ by the government. Increasing unemployment expenses on labour-market today can in this way be combined with the need to carry out building preservation measures on cultural buildings publicly owned by state, region or community. Replacement funding, when employed by private financiers, refers to all voluntary work and man-hour investments; from physical labour to writing articles.

Indirect funding can only be a public heritage support while involving income tax returns on private charitable finance being cut by some percentage. These tax credits on private sponsorship of built heritage imply that the pecuniary gift partly becomes deductible from private earnings. Even if this acknowledgement return may entail only small percentage, yet it seems to be very efficient for strengthening the incentives to fund among private benefactors. The level of tax-exemption differs between nations. The Swedish so called ROT programs can be described as a re-development of the tax credit forms. The difference is that the latter represents directed policy measures, for the government to come to terms with domestic predicaments, by creating new jobs for the building industry¹¹ or to reduce black market labour in the building sector. In *credit funding* the desire of investors is to make profitable investments at growing interest rates¹² which is combined with the need to procure finance for building conservation projects. These forms, which stimulate the financial accelerators, have developed nationally into new forms of risk-free savings when launched by the municipality or the government, such as Municipal bonds in the U.S. *Transmitted funding* involves the financier donating a promotional service to a building conservation project with the sole intention of inspiring others to fund; and in this way markets heritage to the general public.

$$(F + V_A) - C = V_B$$

F = Finance/investment from financier; funding forms (DF/RF/IF/CF/TF)

V_A = value activating funding

C = cost conservation

V_B = marginal value

8.5.2.2 Characteristics and distinctions of private and public financiers

To explore the acquisition of heritage funding three groups of financiers have here been analysed; the private, the public and the alternative. Definition of private financiers was the non-governmentally controlled sponsorship and as a result the most common form used over time. The public one is referring to the governmental and the alternative financiers to potential future heritage financiers, but could also be fitted among the private funding sources, discussed in the next section.

Private financiers were indentified as; trusts, foundations, NPOs and advocacy groups. The NPOs are the most resourceful and independent, yet their success rely on to what extent financial accelerators, which are fundamental for the NPOs, match governmental policy to consent of indirect or credit funding nationally¹³. Advocacy groups are also among the consistent promoters of heritage

funding since they are based on the financially sovereign replacement funding of voluntary work and by forwarding finance request to others, with transmitted funding. Their incentives are emotional accelerators and this requires them to be fully autonomous, thus makes them unpredictable¹⁴. Foundations are vital providers of grants, with their broad dual trigger of emotional and financial accelerators. However, they proved to be less self-supporting since they depend on external finance support in general. Their broader funding strategy, which often is based on a multitude of standpoints for endowments, may at times restrain them from an efficient cultural funding. Trusts, such as the National Trust, primarily have been vital role models for heritage financiers and building protection management. However the NT's present holdings have alas grown into a financial dilemma and reveal that even they have expansion limits to tackle their future dependency on external funding or voluntary labour.

Public funding has national significances, but is generally directed by in what way current governmental policy is set up during the annual finance budget. The two parties responsible for the processing of public funding are the temporary politicians in office, who regulate the national finances and the steady authorities at the National Heritage Boards. Civil servants, authority experts, possess prime expertise of preservation issues, whereas politicians are laymen. The parties' individual value preferences, accelerators and skills, in economics or of built cultural heritage protection, affect the quality of public funding. Depending on the efficiency of their collaboration, either an active intellectual fellowship or *platform*, due to their overlapping historic quantity value (H_3) can prevail, which promotes both the emotional as well as the financial accelerator through public funding. When this option is not considered, a breeding ground for misunderstandings may arise instead. Public funding was initially organized to ensure the new established legal protection acts around 1900, and is viable for the European nations in this study. In nations where built cultural heritage primarily is publicly financed, authority experts remain inactive and consequently unable to influence the funding decisions. Mixed private-public funding, just as support from EU structural funds, will on the contrary engage participation from heritage authorities.

Distinction between public and private funded preservation projects was first revealed in Study 1 and 2 and the assumptions, which later could be verified, were then explained¹⁵ as the financier's value preference characteristics. The capacity of heritage funding of the two groups showed that public subsidy would always be more of a temporary kind than the private equivalent. This is because, first of all, public subsidy is regulated by the annual financial plan and secondly its vulnerability lies in the fact that this endowment only represents a single finance source, whereas private subsidy is pluralistic. Replacement funding, which

is applied in times of recession, to activate unemployed groups, seems not capable of becoming a reliable permanent funding solutions. It is an artificial construction. On the contrary, this type might even reduce the chances for local craftsmen, as for consultant firms, to get established and become profitable within the field of conservation¹⁶. However, public finance could probably become far more resilient if invested into assigned public funds or lotteries with clear-cut goals, such as backing protective measures on non-listed buildings.

The outcome of Study 2 revealed as well that public funding appeared to reduce the number of actors involved which could affect the democratic process¹⁷. It could involve decisions being taken which might become more favourable for a limited number of groups and at times even misused. Certifying consultants and craftsmen, with the intention of avoiding unprofessional involvement in monument protection, may for instance turn out contrary to the initial intention. The restrictions could instead lead to a slow decline in the number of the individual achievements or projects completed, since the selected and certified few might be assigned with too many assignments. Consequently this would diminish the chances to accomplish the best possible workmanship in the end. The future expenses for conservations might be affected as well since the certification prevents the possibility of price control since open purchase is ruled out¹⁸ or it may even be of hindrance for the re-growth of local preservation competence. Indirect, as well as credit funding, also represents public subsidies, as earlier discussed. When employed, the Government then accepts that potential public earnings from income taxes or as a pecuniary transaction, is partly used as inducement devices to encourage private funding. Nations where these additional funding forms were included could verify a positive development. This was for instance recognized as a consequence of the reunion of Germany or as deliberate political decisions aimed at coming to terms with the Government finances in the UK. In both cases the general effect was that the cooperation between politicians and heritage authority experts, on heritage funding issues, did improve.

As cooperative network between dissimilar parties is fundamental and a Swedish exception to the rule was possible to launch in the Halland Model, thanks to European Structural Funds. This new project management form, which arose at the time (Gustafsson 2009) alone may explain its success, though the hands-on building conservations were primarily publicly funded.

Private heritage funding, which refers to all non-governmental support, represents a more consistent alternative to financial backing than the public equivalence. These wide spectra of financiers on various levels in society make some of the parties less self-supporting than others. Pluralistic structures endorse nevertheless a democratic decision-making process in projects, which improve the chances for built legacy to engage many in society. Despite the fact that the main

finance support is allocated from private sources, this structure will still ensure that the decision-making involves public participation and funding through civil servants involvement from the heritage authority boards. Study 1 revealed furthermore that building preservations, which were semi-privately funded¹⁹, would also favour an open purchase which makes it possible to come to terms with the increasing preservation costs²⁰. Broad involvement of actors at all times enabled and anticipated the commitment from the local inhabitants and grassroots.

Constitutional differences for setting up heritage funding, owing to historical development and ideological ideals among the six countries studied, exposed the public funding features; the pure public direction and the more recently developed private-public. The national inducements for encouraging the emotional or financial accelerators will hence determine the success of private funding. Nations, which practise a firm public approach, are primarily limited to direct funding for managing heritage economics; here the latest annual budget plan, of the government, which always regulates its achievements. Countries which never set up a centralized heritage public body, but instead gradually developed a more market based normative framework, on the contrary founded heritage expenses on the financial backing from the private sector, already from the start, as exemplified by New York City. Here motivating financial incentives are continuously developed and explain why these funding options signify a more dynamic approach

8.5.3 What alternative funding groups may be encouraged to heritage support?

Lottery funds proved to be politically the least controversial to stimulate for built heritage allotment, out of the three alternative financiers examined. This can explain its steady appliance as a vital capital resource over the centuries. Funding by means of lotteries is permissive as the investors, and procurer of lottery tickets, need not even be persuaded by the beneficiary's fiscal dilemma to take action, other than looking at the odds of winning a fortune. Lotteries have capacity to engage others and more committed groups in society as well, especially if they are exposed to broadcasting campaigns on television, as has successfully been applied for raising charity by NGOs²¹, or heritage protections in Germany and the Britain. However, by limiting lottery revenues to single beneficiaries, this at the same time will circumscribe lotteries granting independency, which signifies the funding dynamics position of the lottery capital.

To attract the working capital at the credit marked for heritage investments, financial market, contrary to the lotteries, provides a great number of solutions for use. At present the capital market investments are primarily employed as a herit-

age support in the U. S. In the city of New York for example the successful South Street Seaport project verifies its effectiveness, not only at attaining funding for building measures, but also by encouraging authorities, politicians and the private economy to cooperate. Investments in low-risk municipal bonds or portfolios of shares, established in buy back programs could in this way be assigned for monument protection. Other than to assist in urgent cultural heritage projects, credit funding may alert a stronger concern or value for built legacy among new groups in society as well, as has been proved by the use of easements, just as venture capital has been confirmed to be for new established companies²². Any forms of capital speculations require nevertheless that a national policy agreement exists that ensures credibility to set up culture heritage funding based on credits.

Donor groups, in opposition to lotteries and investment market, have to be more personally convinced of a likely success and positive outcome of the project itself, prior to becoming willing to fund. Influential philanthropists most likely stimulate others as role models, to make charitable endowments. Donations sometimes can be utilized for causes generally considered as less noble, such as establishing an enhanced respect in society. For the donor group – receiving updated information on urgent heritage funding needs, which matches their area of competence, is the strategy most likely to succeed. For all endowments to be efficient, incentives such as tax concession or the indirect funding are required.

Financiers	Funding forms	Actions	Accelerators	H ₃ UNS/ Value Preference	
				Rational	Sentiment
Foundations	DF	Threat Information Access	Emotional		H ₁ H ₂
Advocacy groups	RF/TF				
State; Authority	DF				
Donors	DF	Actual & Finance growth Expected	Financial	H ₃ , U, N	
Foundations	DF				
NPO's	DF/CF				
State; Politicians	DF/RF/IF/CF				
Finance market	CF				
Lotteries	DF				
Donors	DF				

Table 853.1 The financiers' characteristics observed in the study are here outlined.

8.5.4 The acquiring of heritage funding

Based on the above discussed findings, accelerators have been systematised to reveal how heritage funding can be initiated and enhanced by the financiers studied. This is because accelerators identify what actions; external conditions, society needs to ensure through governmental policy so as to motivate an economic be-

haviour of financiers. By exposing what measures to take, random heritage policy decisions could from then on be avoided, and thus replaced by approaches conveying clear cut goals, where building legacy is guaranteed by fulfilling required national needs and expectations. All private, public and alternative financiers in this final section have thus been structured consistently with their accelerators' affinity, and this was why initially seven financiers²³ became three groups, while induced either by; the financial accelerator, the mixed of emotional-financial or the purely emotional one, (see table 854.1).

Groups	Financiers	Funding forms	Actions	Accelerators	VP	Sustainability
I	NPO's	DF/CF	a/e finance gr.	FA	H ₁ , U, N	Heritage funding!!
	Fin. Market	CF				
	Lotteries	DF				
	State; P	DF/RF/IF/CF				
II			information access	EA/FA	H ₁ , H ₂ , H ₃	Heritage funding?
	Foundations	DF	a/e finance gr.			
	Donors	DF				
	State; A	DF				
III	Adv. groups	RF/TF	information access	EA	H ₁ , H ₂	"Heritage funding"

Table 854.1 The financiers studied are here structured consistent with their accelerators' affinity into three groups.

The first group is financially the most solid and self-sufficient one, with their direct funding. It includes the NPOs, the finance market and the lottery funds. The NPOs ability moreover to set up credit funding, stabilizes their position even as investment mediator. The second group entails the weaker ones, with less self-supportive foundations and donors, which allocate equally a direct funding for built heritage. The parties' limited value preference, excluding *Utility* and *Nominal values*, explains that they either are financially independent or constantly vulnerable to running at a financial loss. The advocacy group finally, in the last third group, has a broad economic behaviour, which makes them most durable. However, neither their transmitted funding; to encourage others to heritage funding, nor the replacement funding of manpower, need external backing, as they are free of charge. Their independency makes them unreliable though, since they often exist on a voluntary basis. When NPOs and advocacy groups collaborate on heritage funding issues this makes them into a most solid team with a complete value preference and extensive funding capacity; from cash to manpower.

When acquiring heritage funding, the external actions have to be established, which in succession stimulate the accelerators. The emotional accelerators convey, to begin with, the perception, of the historic quality (H₁) and the historic knowledge value (H₂). The notion of a subconscious and often inherited link

between monuments, man and history, which Goethe described in literature, refers to the Historic Quality Value. Moreover the Historic Knowledge Value is the scholarly, or academic, interpretation of history, practised by Winklemann, and it represents the collection of facts through scientific studies²⁴. The more intense a field of knowledge becomes the more affectionately an involvement will grow to ancient structures, even with an academic approach. This fact explains the relation that H₂ has to emotional accelerators. This assessment's direction matches the value preference of following four finance benefactors; the Foundations, the Advocacy group, the Donors and public funding; authority. The actions inducing the emotional accelerator, of information and access, refer to strong intellectual reimbursement, which can prevail over generations, providing that measures are on offer, as exemplified below.

Action of *information* to stimulate emotional accelerators can be exemplified by;

- All written facts ever produced about built cultural heritage sites and its protections, should be made publicly available. Here the Internet offers an excellent opportunity, both for establishing search tools on existing archived materials or to store the most recently produced documents, by the authorities or private consultants and firms like the Fischer's Raumbuch²⁵. Other facts regarding architecture or the building physics, even budget calculations could be included. The enticement to implement these publications would be to improve the dialogue between the public and local private sector on conservation matters. This could be an opportunity for skilled local firms to gain media exposure, but also for the systematizing of facts to scientific studies.
- Brochures, free of charge, covering all heritage conservation subjects, from the hands-on measures on the constructions in practice to the refined awareness discussions are important. The sale of advertisements for local relevant enterprises and businesses could enable the spreading of the brochures at local and regional level.
- The “family stories” from local inhabitants about the cultural buildings would bring back community spirit to the built environment, even to young people, by including old photos from private albums and other nostalgic memorabilia. The opportunity for local businesses to place free advertisements for attracting tourism might in this case bring in the vital means. Young people could put together the relevant Web sites as a temporary job or as part of an apprenticeship, under guidance from educational institutions.

Action of *access* to stimulate emotional accelerators can be exemplified by;

- Re-establish a ceremonial function and the social contextual significance for the legacy, by providing temporary or regular admittance to the built heritage site for all in society.
- Local or regional heritage authority's back-ups of private individuals to join in historical groups, which work on a voluntary basis working to assemble and to publish archived materials. Here the independency of the group is most essential and no financial compensations are to be involved²⁶. Cooperation between senior citizens and school children would in this case be prime opportunities as regards promoting future heritage protections.
- Practical building conservation camps²⁷, associations, on a voluntary basis open to young people, students or interested private individuals, free of charge. Under guidance of and arranged by local heritage authorities and private consultants, these could be run in cooperation with educational institutions. Sponsorship from local building material suppliers could help realize support for the building conservation camps.

A financial accelerator makes a financier perceive the historical quantity (H_3), the Utility (U) and the Nominal value (N) in the built legacy. Dvorač efficiently exposed this tangible *historic quantity* value in his protection manual²⁸ on surface authenticity to prevent large-scale style restorations. The judgment epithet of the exterior's settings that is available involves all aspects; from the number of façade decorations to the amount of genuine building fabric. The *Utility* value in the Roman Empire's ancient architecture was at hand in its embodied energy²⁹ by succeeding generations, with devastating recycling measures as result. Yet the French Classments promoted the same value unit for ensuring building protection, but with the distinction of the re-use in situ, with the Louvre museum as one of the first examples. Restriction on building adaptations has clearly proved to be counter-productive to the intentions. Finally the nominal value reflects the financial investment made in built cultural heritage as, the presumed revenues or marginal output of funding. This ascends subsequent conservations, or investments made, and will drop when hit by un-skilled craftsmanship or incompetent building alterations.

Financiers with value preferences matching the assessment units described, were the Foundations, the NPOs, the Financial market, the Lottery funds, the Donors and the public funding via politicians. Actions inducing financial accelerator; actual and expected finance growth, in contradiction to the emotional

one, is more of a short-lived or instant feature, but then again the easiest achievable of the two.

Actions of *actual as well as expected finance growth* to stimulate the financial accelerators can be exemplified by;

- Eye-catching and striking media attention for the built cultural environment through broadcasting to attract cultural tourism for the built cultural heritage. The means of communication would favour the heritage sites and encourage local businesses and so provide job opportunities³⁰. For this to happen, indirect and credit funding are essential.

- The encouragement of an income bringing re-cycling in situ of the cultural inheritance by the skilful building adaptations. This implies establishing a more dynamic relation to the normative legal acts by encouraging a heritage site's future utilization. It is always essential to give the local building firms and consultants the first opportunity to participate by offering open procurement for all tenders. This would ensure local expertise is harnessed and a sustainable heritage protection. For these issues once more indirect and credit funding are vital.

- The establishment of the built cultural heritage as a saving opportunity, this enables the potential rent increase on investments, by politically accepting the indirect and credit funding and involves four issues. First of all tax-exemption for the endowments favourable for cultural heritage protective needs, has to be offered. Secondly the establishment of bonds linked to building conservation venture must be set up by the authority, either at; the central, regional or municipal level. Thirdly, shares established in buy back programs could be developed by the private sector³¹. As fourth and final, the introduction of historic preservation easements by a non-profit easement-holding organization, like an NPO³². The binding contract between the owner and a qualified organization, regarding building facades, will insure its future maintenance, as neglect will prevent a future value increase. Tax concessions and bonds offer a governmentally controllable, brief and non-committing capital investment. The shares-options, just like the easement of proposals from the private sector, are a long term investment and savings. For all of which indirect and credit funding once more will be essential.

- Public funds of "earmarked" means dedicated to promoting built legacy, such as non-listed buildings, has proved to initiate additional private funding since the total support called for, then will be within reach.

In conclusion; *What characterize the present and alternative funding sources of cultural heritage?* Individuality characterizes the financiers scrutinized, which in this study is defined as their unique set of value preferences. Once these were identified then the accelerators projecting them, just like the stimulating actions in concert, disclosed their mechanism of funding. Hence; to determine how to encourage heritage funding from the present and alternative funding sources studied effectively, involved establishing what accelerator among them was the most frequent. The table 854.1 reveals that a majority was induced to funding by financial accelerators, while fewer benefactors would be so by emotional accelerators³³. Emotional accelerators concern nations' historical past and to what extent populations have experienced that their building legacy was endangered, thus emotional accelerators become unfeasible to impose artificially. Since financial ones in contrast are easy to institute by policy adjustment in favour of indirect funding, such as tax credits, this indicates a promising result.

8.6 Step 4; economizing funding

8.6.1 Building phases turn built heritage to actions

Building conservation will always be difficult to cost estimate fully. Initially hidden constructional damages can emerge once work has started and even load bearing durability estimates turn out to be totally false. Moreover, the three dimension characteristic of built heritage frequently encourages a great variety of objectives as to its outcome, among the many professionals engaged, due to their unique value preferences. Discussions on how to go about the conservation work in practice hence occur at the building sites and this can lead to costly reconsideration. The economizing proposition, for meeting the fiscal deficiency in heritage economics, could firstly be possible by adjusting the building phase distributions at the building sites, by a resourceful regulation of the building measures in accordance with the available funding. Secondly, building conservation sites as such have capacity to generate income³⁴ as vertical archaeology, both due to the considerable amount of new knowledge that the work reveals and since the layers of historical fabric induce strong feelings among observers about emotional ties to the past. The different building phases of a conservation project, which each generates separate costs, were here defined as; shell-repair, adaptation and preservation (C_{SAP}). In the study these were identified as having unique marketing potentials as actions, inducing accelerators projecting values. This was why conservations projects that included both the shell-repair and the adaptation phases

(C_{SA}) generated funding from all financiers, due to the phases' positive environmental impact on creating finance growth. The detailed and scientifically incited preservations (C_p) in this case, proved to have the least funding inducing capacity and this is why the building phases need to be distributed carefully with intent, (see table 72.7).

The goal of getting all the building work done "all at once" which is often the aim in the presence of a temporary high finance input, and typical for a new build, for this reason seems incorrect for building conservation projects. Intentional limitations of a building conservation's extent or size could instead improve the chances for a project to reach temporary goals and at the same time reduce costs. A deliberate ranking or distribution of the building phases, according to preservation urgency to minimize damages, would most likely enable the expenditures to be extended over time; between investors, financiers and generations, thus economizing funding. In this way the building phases themselves become the external actions which stimulate emotional or financial accelerators of man. They sequentially are projecting hidden values for the built cultural heritage in question.

Other than adjusting the building measures to economize funding, the building site as such can be adapted to market the so-called vertical archaeology revealing the layers of time, in historic buildings. These resources of knowledge, attained in theory and practice, or memory, possible to reveal in all building conservations, when made publicly accessible, can provide income and will induce finance growth locally as financial accelerators. Intentional distribution of conservation planning cannot only cut the present costs, or provide a temporary income, but since such planning involves engaging in dialogue locally, it also leads the way for likely future funding.

The findings from the analysis of the conservations of The St. Jakobi Church, The Rossewitz palace and Murray's Mills showed that redistribution of the building conservation practice is applied, intentionally or unintentionally, for economizing funding as revealed below;

- The privately funded church and mill projects applied intentional distribution or ranking of the building phases, which thus economized funding to induce the emotional and financial accelerators for value growth and income.
- The publicly funded manor house initially was structured like the others, but the loss of a key manager, as the architect resigned due to poor health, severely affected the outcome and local connection, which revealed the danger inherent in public funded ventures, having only a small number of actors involved.

- Disruption in project management of the manor house cut off the regional involvement and might explain the venture's uncompleted status. The site still lacks a goal for its future use.

8.6.2 Implication of heritage funding on building conservation

To apply the economizing of funding as suggested above, indirect funding needs to be accepted nationally and can be fully implemented once credit funding is applied as well, especially with finance instruments like easements. The form funding has in this way can be said to influence building conservations far more than one might expect.

The sketch below illustrates how the diverse heritage funding applied over time can be said to have influenced the development of building conservation practice. Until the 1850's, building conservation was like patch work, with measures according to the needs, which today are disclosed in the historical layers. Style restorations, as mentioned earlier, can be said to have their roots in the European wealth on account of industrialism. New capitalists, banks and industrialist arouse and they were eager to show off their wealth in the expanding cities. The new shining city centres made the historic monuments in comparison look even more dilapidated since they represented patched maintenance, which is why new culture heritage philanthropists joined the city councils for subsidizing building restorations. Here the resurrection of Cologne Cathedral set the tone. With the frenzy of the age of the new archaeological science, historians and architects took a scientific approach; back to basic drawings and restorations finally presented "new historic legacy". The outrage and protests that followed enabled finally public bodies of antiquity boards to be set up and legally regulate building conservations. In a way centralization of the heritage management shut the door also to the private funding of building conservations.

Nations, which during the 20th century deliberately have changed their financial policy, in order to promote private funding; by tax-concession in indirect funding, have had a positive development for the heritage sector. This was for instance a positive effect of the reunion of Germany or subsequent the political decisions for coming to terms with the Government finances in the UK in the 1990's. The future, with the growing finance deficit, calls however for a new approach, such as using intentional distribution of the building phases; conservation works at the sites, as actions to stimulate the vital accelerators. Based on the preservation urgency, this approach could be an answer for economizing the heritage funding and by publicly marketing the building sites for its *vertical archaeology* incomes could also be gained.

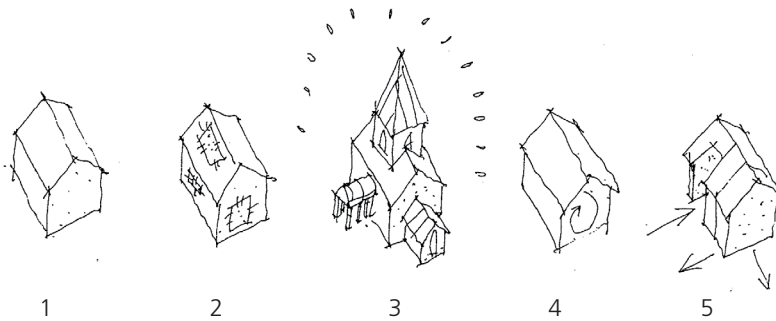

Figure 873.2 The sketch illustrates how the diverse heritage funding applied over time can be said to have influenced the development of building conservation works in practice (reality). The new building (1), the patchwork maintenance establish historic layers with private funding (2), the style purification thanks to industrialization, private funding (3), the national heritage boards centralized building conservation based on public funding (4). The future solution; intentional distribution of conservation works, with open building sites, for solving the deficit and encourage mixed private-public funding (5).

In other words; *Can building conservation practice be redistributed to reduce costs?* Purposeful spreading out or re-scheduling of the building conservation phases; an intentional distribution, itemizing them as referring to separate costs, C_{SAP} , can most likely reduce costs by launching heritage marketing on the basis of two perspectives. First of all these phases can have a ranking of their priority order and the size of the jobs, according to preservation urgency, which is consistent with their own abilities to promote values in heritage, which regulates funding. The different value encouragement capacity makes some building phases more intriguing to fund than others are. This indicates that expenditures could be extended over time or among investors, financiers and generations, thus *economizing* funding. Secondly, the promotion involves making use of what I have in this dissertation labelled *vertical archaeology* in heritage. The building site itself can in this way bring income by exposing the gained knowledge or memory assets, during the conservation period.

$$(F + V_A) - C = V_B$$

F= Finance/investment from financier

V_A = value activating funding

C= cost conservation; C_{SAP} : shell-repair, adaptation, preservation

V_B = marginal value

8.7 Step 5; assuring funding

8.7.1 Future conditions of built heritage are actions inducing funding

Conservation of a building cannot be executed once and for all, due to the weathering of materials. This makes the protection requirement perpetual, but possible in contradiction to maintenance free materials, which have to be disposed of, and so its finance support has to be revolving. For this reason steps have to be taken so financiers will remain inclined to continue their support. With the assumption given that values in historic buildings are incessantly present, they are also revivable when stabilized by accelerators, in turn stimulated by actions. In other words the mechanisms of funding will be strong as long as the outcome; the preserved built heritage, which consequently become the *action*, will stimulate accelerators, so financiers will perceive qualities they appreciate; value preferences, in building legacy.

The outcome of the conservations of The St. Jakobi church, The Rossewitz palace and Murray's Mills were once more explored to see the extent of how the revolving funding was assured as an achievable future gain, as summarized below;

- All projects revealed that the future gain (V_B) from a constructional aspect, was ensured and damages thus reduced to a minimum by the general use of empirically tested building material in all building conservations.
- Only the palace had a reduced capacity to attain revolving funding. Here the accelerators failed to project the values since the vital actions were absent; the palace is still unfinished and closed to the public. The facades and the former park still fail to disclose the extent of the conservation works.

Case study according the heritage finance model							
Step 4 and 5	Economize funding CSAP					Assure funding VB	
Projects	Save actions			accelerator	Income V. arch	compatible	marginal
	Info.	access	fin. growth			Technical	$V_B > V_A$
	Jacobi	OK	OK	OK	EA & FA	OK	OK
Rossewitz	OK?	----	----	EA?	----	OK	----
Mills	OK	----	OK	EA & FA	OK	OK	OK

Table 871.1 The conclusion of the economizing and assuring of funding made in the three case studies analysed.

So, in order to provide the answer to; *How could an economically sustainable finance model be structured*...? Future gain, here referring to marginal value (V_B), in every preserved built heritage has to be guaranteed in order to assure a revolving funding, just as the value activating funding (V_A) is required for any heritage funding to commence. In view of all new inputs made, the marginal value of conservation ventures, hence have to exceed the one which first induced the funding, so that; $V_B > V_A$. Only this makes the finance model sustainable and beneficial for future heritage economics. Prospective positive marginal values for built heritage can first of all be ensured technically when all conservation measures strive for the re-use of compatible and empirically tested building materials. Since these have already been applied through centuries of continuous usage, the damages will be reduced, hence ensuring an increase of a site's nominal value³⁵. Secondly, a positive outcome requires that the building heritage remains rooted locally by fulfilling expectations of the community³⁶, such as evident outputs on investments³⁷, and so having the ability to nourish the mechanism of funding. Every preserved building will in this way, as the external *actions*, be stimulating the emotional or financial accelerators of society, to perceive value awareness in built heritage.

$$(F+ V_A) -C = V_B$$

F= Finance/investment from financier

V_A = value activating funding

C= cost conservation

V_B = marginal value; $V_B > V_A$ or future gain

To assure such re-occurring funding, the indirect funding form has to be nationally accepted. When the credit funding form is in place as well, the future asset value of the preserved built heritage could be guaranteed fully.

8.8 The notion of value

8.8.1 Accelerators stabilize projected value targets by revealing paybacks

"In a fundamental sense the notion of "value" is the origin and motivation for all economic behaviour" (Throsby 2004). This assertion by Throsby may imply that a perfect inclusive value scale actually could be possible to develop with the capacity to elucidate all qualities of built heritage³⁸. However, the question still remains whether a value concept which is totally independent of changes over time; such as intangible languages or cultural barriers – could ever be set up, other than

in theory. Merely its interpretation by man makes it indistinct due to the individualized value preferences and point in time, which the legal value framework verifies³⁹. One definition of heritage value at one time in the legal text might later on never be fully understood, since it is by nature, time reliant. This is why the legal protection definitions of build cultural heritage are continuously widening. Moreover the more detailed a value concept becomes, in order to achieve precision; the more vulnerable it will also be to misinterpretation⁴⁰. An assessment of the multi-criteria method for this reason, first of all, is a passive device which is the most suitable for distinguishing phenomenon in theory, but less efficient for use in practise. Value concepts, for this reason, might not single-handedly manage to stabilize the value assessment of build cultural heritage needed to secure its protection.

A second approach to resolve Throsby's value claim would be to transform the value dialogue into more agreeable entities, which is a computable form such as the TVM, CMV or the CBA methods suggest (see 1.6). These transferee assessments of the cultural worth into fiscal amounts should in this way be sufficient for any financiers to see the objective of financial commitments. The numerically offered value outcomes then again have been criticised, since they might promise a level of precision that actually is not possible to achieve.

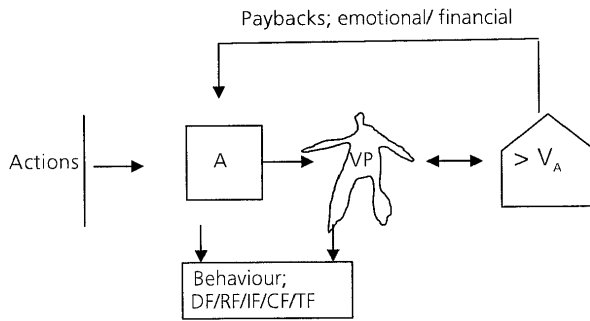

Figure 881.1 The notion of a positive payback motivate the economic behaviour such as funding built cultural heritage. The notion is equivalent to the accelerator. In order to stabilize the value of our built heritage, society requires guarantees on the payback capacity of a funding commitment. Value concepts, or mental targets, are most accurate when re-established every time at the building site, and based on the party's value preferences on buildings.

Let us shift the focal point of the expression by Throsby and instead say that the origin for economic behaviour is to be interpreted as the *notion* alone. Consequently, if the significance were interpreted as the *notion* this would displace the deed of funding from the changeable and unreliable value concept ideal,

to the more basic and solid *motivation for the behaviour*, which would be the *notion* of something positive for the benefactor. In other words this would underline the fact that economic behaviour should first of all be induced by the likely *payback* that a sponsorship commitment might foresee. The human conduct would in this way determine the undertaking, such as funding, while the value concept then would be equivalent to its individual intellectual targets or goals. The “*notion*”, by Throsby, is consequently equivalent to the accelerators, revealed in this study. These disclose, not only the motive for a financier, but also explain how the endowments or economic behaviour will provide profitable payback or reimbursement for a benefactor, though not necessarily only as cash returns. All analyses of the acquiring, economizing and assuring of funding disclosed the vital impact of the accelerators.

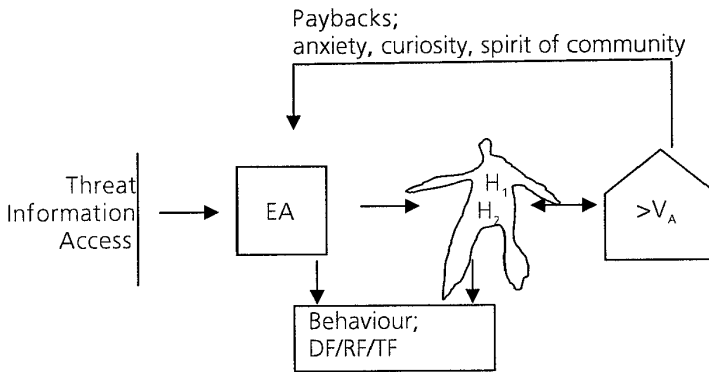

Figure 881.2 Emotional payback on emotional accelerators and actions.

The accelerators projecting values can be explained as unfolding the basic human qualities and the payback then becomes equivalent to intellectual and physical proceeds. Emotional accelerators can be referring to the human properties of; anxiety, curiosity or spirit of community when evoked by the actions of *threat, information* or *access*, The anxiety emotion for instance needs to be settled, or repaid, instantly and then initiate or accelerates a process to ease the mind. For built heritage this can turn out as either of the five funding forms described⁴¹. Curiosity emotions may stimulate the urge for knowledge and the spirit of community reimburses a sense of belonging. The financial accelerator in the same way could be labelled as the personal properties of greediness, satisfaction or economical behaviour when encouraged by actions of *actual* or *expected* financial growth.

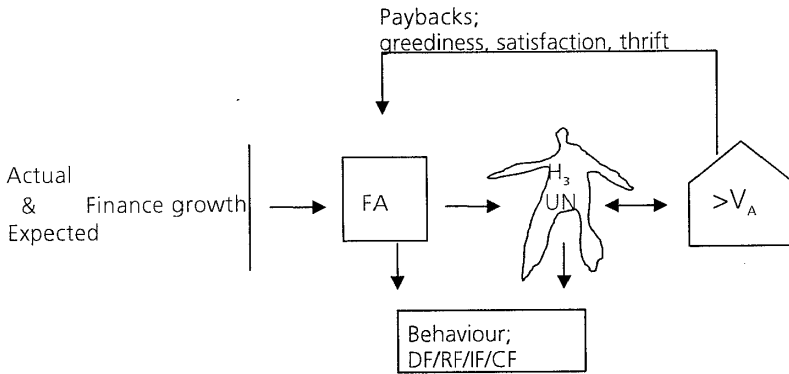

Figure 881.3 Financial payback on financial accelerators and actions.

If we are to claim this significance of the accelerators' impact of human behaviour, it is most important for the heritage funding, to emphasise the result that they, in contradiction to the conceptual value interpretations, are globally understood and viable over time. The accelerators stimulated by actions, are describing a spontaneous human act already applied within trade over centuries, in contradiction to the contemplative interpretation of conceptual value authorized for building heritage in protective decrees around 1900. To establish a sense of guarantee that outcomes of a funding behaviour is, or can be prosperous, by revealing its payback capacity for society, this conviction might primarily make the value of the built heritage stable. This is how accelerators could be controlled. The conceptual value interpretations in theory will, on the other hand, always be shifting. Consequently for a value concept like H_3UN to enhance a financial commitment, this can only be applied when considering the action- accelerator-value relation; the mechanism of funding. The most accurate value concepts, or mental targets, thus have to be re-established every time at the building site, to promote a successful dialogue, by registering the party's value preferences on built environments. One should therefore never assume that a standardized "full set" value concept is feasible to use, not even by "educating" all groups in society. Processes showing how actions stimulate accelerators are present at all times since they represent an essence of human conduct.

In the next section the vital impact of the accelerators has been scrutinized based on two aspects; first to verify its significance for the outcome in three cases of building protections and secondly illustrating a suggested intellectual outline of the mechanism of funding in conservation projects. Moreover, recent examples of other funding ventures have additionally been added, with the intention of suggesting that the same intellectual processes; mechanism of funding, take place

outside the heritage sector as well, hence this intellectual map illustrating the action-accelerator-value definitions, might be of use for other strategic funding planning. Finally the inadequate heritage funding in Sweden is discussed from the accelerator standpoint.

8.8.2 Accelerators' impact on the funding mechanisms; value decline or raise

To disclose the impact of accelerators for the acquiring, economizing and assuring of funding, three built heritage projects have been analysed in this section. The H₃UNS value concept is applied as an index to expose how the heritage acceptance due to external conditions may change, thus exposing the mechanisms of funding in reality. A complete value concept represents a full recognition of building legacy, which hence makes it agreeable for many benefactors to support. A value decrease due to chancing external actions will conceal values and so the accelerators may only motivate a few financiers. The first example again depicts the New Maglarp Church, discussed already in chapter 1, but this time based on two scenarios. The first one outlines the actual process that took place and the second a feasible development where the building is rescued. The Allhelgona is the third example, which in contrast outlines a successful outcome. The fourth one finally illustrates the restoration of the Polish Kosciol Mariacki church and it represents an international perspective.

8.8.2.1 The New Maglarp Church; emotional and financial accelerators (EA/FA)

The rise and fall of new Maglarp Church, (table 8821.1), illustrates how the respect for the new temple, initially manifesting optimism and the growing prosperity, ceased in less than a century and finally the building was demolished. The exterior actions of investments by the parish for the installation of electricity in 1948 briefly strengthened its value but only two decades later, in the 1970's, the church doors were closed forever. This decision made it legitimate for the parish to reduce the heating and maintenance costs as well. An unintentional consequence also was that it excluded the possibility for all generations born after 1976 to establish any emotional relations to the building⁴². The non-use of the church for three decades sealed the church destiny locally since a few senior inhabitants only, considered the demolition as a threat. The shock budget in 2004 with the exponential cost increase of 28 million in 12 years⁴³ definitely had a decisive effect on the outcome. Price estimation may unfortunately be misused, thus it is by some professionals considered to be "forbidden calculations"⁴⁴ when applied to heritage matters. The question is -whom they serve? Especially when considering

that the complete preservation costs for historic buildings are hard to determine⁴⁵. Some additional circumstances undermining the value and contributing to the decline of New Maglarp were furthermore the request from one party regarding brickwork re-use, as recycling matched that company's image⁴⁶, the planning of an expanding adjacent residential area⁴⁷ and the fact that the bishopric actually paid for the demolition costs.

year	action	accelerator	values change
1907	new erection (access/information)	EA/FA	H ₃ UNS
1948	electrification (finance growth)	FA	+UN
1976	closed doors (-access)	EA	H ₃ N (-US)
	No heating/maintenance costs (fin. growth)	FA	undermine
2004	"budget" (threat)	EA	H _{2,3} N (-H ₁)
	"budget" (loss)	FA	H _{2,3} (-N)
2007	demolition (-information)	EA	(-H ₂ -H ₃)
	recycled brickwork	FA	undermine
	expanding residential area	FA	undermine
	sponsored demolition (for free)	FA	undermine

Table 8821.1 *The rise and fall of New Maglarp Church.*

Finally, to determine if the church destruction actually was an efficient method for solving finance deficits, all expenses generated by the demolition then have to be taken into consideration⁴⁸. Furthermore the income loss for the local brickwork industry needed to be added since the company's new visitor's centre was built out of the recycled Maglarp bricks. The status of New Maglarp Church in 2007 prevented society from seeing any reasons for prohibiting its demolition. Important for all parties to consider is that the destruction of New Maglarp may turn into a standard practice for parishes to solve their financial inaccuracies, unless the antiquity board change the inflexible policy stance which prohibits church adaptations⁴⁹.

Could new steps have been taken to prevent the New Maglarp demolition or was the 30 million SEK missing the only solution? First of all had actions of access and information been initiated locally, these might have been perceived as emotional accelerators (EA) which could have re-stabilized the essential historical values by altering the external condition.

year	action	accelerator	value change
2007	open (access)	EA	H ₁
	literature (information)	EA	H ₂
	broadcasting (information)	EA	H ₃
	lottery funds	FA	N
	indirect funding (finance growth)	FA	N
	credit funding (finance growth)	FA	N
	adaptation (finance growth)	FA	U
2009		EA/FA	H ₃ UN

Table 8821.2 A proposed draft of a likely value rise for New Maglarp Church.

Access in the sense of unlocking the church doors for local arrangements could here be employed, and on a national level too, if involving television broadcasting. Parallel to this spreading of information, such as literature or brochures, would be required to enhance the intellectual appreciation. The potential value increase locally then, might have stimulated other groups to perceive the Maglarp case as a source or action, stimulating financial accelerators and to arrange a local lottery fund dedicated at taking protective measures as regards the church. Then eventually if positive results could be seen, this might have given sufficient enticements to politicians and future decision-makers to approve an indirect or even credit funding. If private funding had been induced by policy incentives revealing paybacks, this might have motivated some parties to become involved in the future church destiny and others to contribute financially.

With the H₃UNS concept as value index, the external actions impact of the emotional and financial accelerator could be registered. Both accelerator groups were affecting the decline in the level of respect, just as they did possible reverence, shown towards New Maglarp. The proposed draft of a likely value rise for the church could be encouraged by actions inducing the emotional accelerators. For this reason the best approach for the parish was probably not to wait for the 30 million SEK, but instead to launch some low-cost arrangements stimulating emotional accelerators. Eventually these might tempt financial accelerators as actions, such as indirect or credit funding of actual or expected finance growth, to preserve the New Maglarp Church.

8.8.2.2 The Allhelgona Church; financial accelerators (FA)

The Allhelgona church project began while the public museum, which was located in the vicinity of the church, was expanding. The venture managed to acquire funding due to three coinciding external conditions, or actions, which were enhancing its value and consequently the financier's perception of its positive outcome. First of all the separation of church from state involved a new situation

which contributed to the profane adaptation in utilization. Secondly, it was the parish's inability to invest in a new heating system. Thirdly the recent Swedish EU membership at the time⁵⁰ was introducing programs of cultural funds to induce regional development.

year	action	accelerator	value change
1990	failure heating system (- growth)	FA	N
1995	EU- funding programs (growth)	FA	N
2000	division of church from state (growth /po)	FA PA	U (S)
2001	Brahe museum expansion (growth)	FA	U

Table 8822.1 The external actions inducing the accelerators for funding of the Allhelgona Church, registered in H_3 UNS's units only involved the financial accelerator.

On account of the external circumstances four different financiers became involved in the project, each with their own motivation, or value perspectives, for supporting financially; the original proprietor, the new one, the community and the EU program. The only non-governmental capital in the project was the church donation itself from the parish⁵¹. This contribution was induced by their wish to be alleviated from the maintenance commitment (N)⁵². The new owner; the National Property Board SFV, was engaged financially to ensure the maintenance of all load-bearing constructions (UN), but the Landskrona community primarily looked at its regional development potentials, from job opportunities to tourist profits (U). The international EU programme's main focus with their subsidy was to introduce the international platform of cultural exchange at regional level and to link nations through projects of common concern. The motivation variety of the financiers reflects their individual value preferences (VP) in the Allhelgona scheme. Here actually only two; the present and the former owners, were encouraged by the church building while the others by its capacity to generate positive contextual prosperity growth. The many financiers nonetheless ensured that splitting the costs, no matter what their initial motives could launch the church adaptation and also ensure the democratic process.

The opportunity for economizing the funding was possible in the projects. The items of expenditure were distributed so the *shell repair* became the owners' concern (SFV) and by promoting the museum scheme at national as well as international level, the *adaptation* was sponsored by the community of Landskrona and the EU program. The indisputable future gain of the church will assure a recurring funding for Allhelgona as museum and also as the refurbishment included additional buildings at the site as well. Today a visit provides a wide range of income generating aspects on account of the 16th century astronomer Tycho

Brahe's life and work for the community, although the scientist's reputation as an abuser of farmers' rights still prevails on the island of Ven.

The external actions inducing the accelerators for funding, registered in the H₃UNS value concept index, only involved the financial accelerator by enhancing the nominal and utility values. The emotional accelerators were missing, as the historical ties to the church were fable among the financiers. Only the parish then would come into question, but they sold the building for a symbolic sum, on financial grounds.

8.8.2.3 The Kosciol Mariacki; emotional accelerators (EA)

In order to illustrate the accelerator effects further, but this time from an international perspective, the Kosciol Mariacki restoration project, former Marienkirche from Study 1, has been explored here, (table 8823.1). The preservation reveals the situation in a nation where the built heritage sector has undergone a total change since 1990. The Polish built heritage used to be publicly funded and maintained under the skilled guidance of the PKZ⁵³. Today fiscal support is also attainable from the private sector, due to the national introduction of indirect funding⁵⁴. Since the Polish built legacy was always of high significance as physical history, these new investments forms have given new opportunities and positive side effects nationally, even outside the heritage sector.

year	action	accelerators	value change
1986	The promoter revisits the church (access)	EA	H ₁
1987-88	Advocacy groups established (access)	EA	H ₁
1988	Polish and German youth (information)	EA	H _{1,2} , H ₂
1990	The parish regains the church (access+ info)	EA	H _{1,2}
1991-93	Students set up the blue prints (information)	EA	H ₂
1994	The 750 city celebration (access)	EA	H _{1,2}
2009-	Investments state/federal Pol./Ger.	EA	H _{1,2}

Table 8823.1 Emotional accelerators alone induced the restoration or Kosciol Mariacki in Chojna.

When the staircase in the church tower of Kosciol Mariacki in Chojna was finally rebuilt in 2009, this marked the end of more than 20 years of church restoration. Two decades earlier this monument was standing an open ruin, having been destroyed by fire in the 1940's. The building was left with only the brick walls, a hollow church tower and nine of the clustered piers still intact. On account of the confidence and the persistence of a former parish member⁵⁵ this exceptional church reconstruction was initiated in the 1990's. Subsequent to a visit to the site this one man developed a strong desire, which grew even stronger; to one day rebuild the 14th century gothic cathedral. Before the Second World War, Chojna

used to be Königsberg (Neumark) and German territory. As the plans were made official, other former inhabitants of Königsberg, today resident in Germany soon established themselves as advocacy groups to promote the recreation of the ruined *Marienkirche*. The project was launched and publicly funded⁵⁶ as a joint venture between Poland and Germany where representatives from all legal levels were involved; from the local inhabitants up to governmental rank.

In 1988 Polish and German youth groups together were involved in the first clearing works at the ruins. Architect students from Szczecin Technical University later could draw up the blue prints, subsequent to their detailed measurements of the remaining brickwork constructions. The local parish applied to the Polish government and so regained the church ruin which had been nationalized after 1945⁵⁷. The 750 year city celebration in 1994 developed into an annual Polish-German city feast. The outcome of the restoration not only brought a re-created church building to life but also was a local reconciliation between nations. This undertaking furthermore raised local self-esteem, and encouraged the Polish acceptance of the former German Chojna to grow, even among the most sceptical groups of compulsory transferred former east Poles⁵⁸ in the town. The venture also managed to endure the often animated discussions, from distrust to final agreements, even though the project objectives or values were diverging. The Germans above all saw the historically correct resurrection of Kosciol Mariacki as the logical outcome, whereas the Polish representatives were exploring the future character of their new post-war built heritage. However, when considering the initially poor constructional condition of the church, never once were there doubts that the unfeasible and costly project ever should be annulled. The economizing has been applied and assuring of funding most likely will be solved.

In conclusion, emotional accelerators alone induced the latter Kosciol Mariacki restoration in contrast to the Allhelgona project, which was encouraged by financial ones. The financiers' sincere historical commitment for the Polish church, reflected in their value preferences, can explain that strong emotional accelerators most likely need to be inherited and they definitively were essential for this spectacular church reconstruction. The financiers of Allhelgona, on the other hand, had a rational objective for the church; to increase the proceeds. This could be achieved as the EU's structural fund was within reach and in this case the lack of emotional accelerators might even have facilitated the venture. Yet, without this pragmatic attitude, the museum expansion on Ven would hardly have been launched. In the hypothesized resurrection of values for Maglarp, in order to have avoided its demolition, minor inexpensive measures could have been suggested for inducing emotional accelerators, which may have re-inspired the financial ones. The owner's passiveness in this scenario made the bad prospects for the church even worse. All outlined building ventures verify the significance of ac-

celerators for their outcomes, when responding to external actions. Emotional and financial accelerators are projecting values in building heritage, which induce human conduct as thriving goals by promising tangible or intangible payback returns.

8.8.2.4 Illustrated mechanism of funding;
 – Allhelgona, Kosciol Mariacki and a research centre

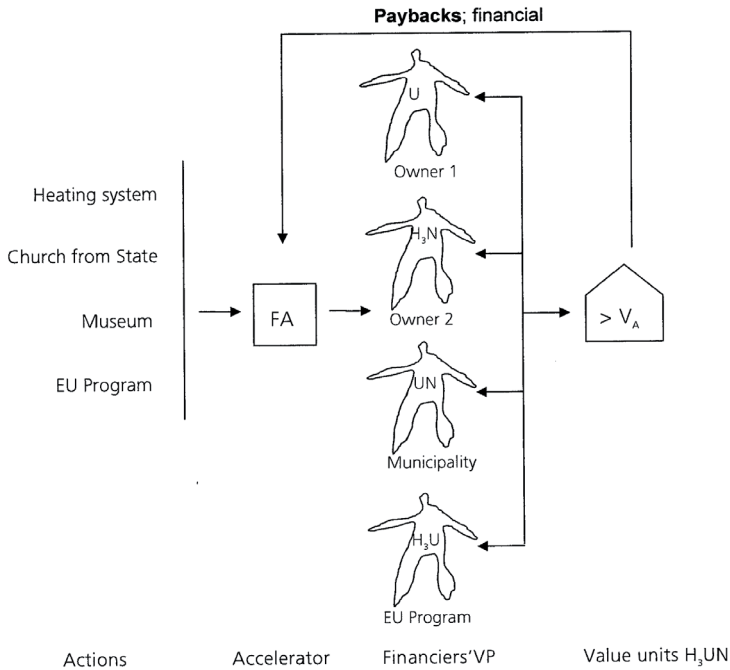

8824.1 Allhelgona Brahe Museum

The outline proposes the mechanism of funding of the Allhelgona Church project i.e. how four financiers (owner I-II, Municipality, EU Program) reacted on different actions (heating system default, church's merge from state, museum plans, EU Program support), which in turn stimulated their financial accelerator to see values (their own VP) in the Allhelgona adaptation. This gave the benefactors a sense of guarantee that the outcomes of their funding commitment would be prosperous, by revealing a payback capacity for them. The financiers' certainty that they were right, in doing so, is what stabilized the value of heritage like the Allhelgona church.

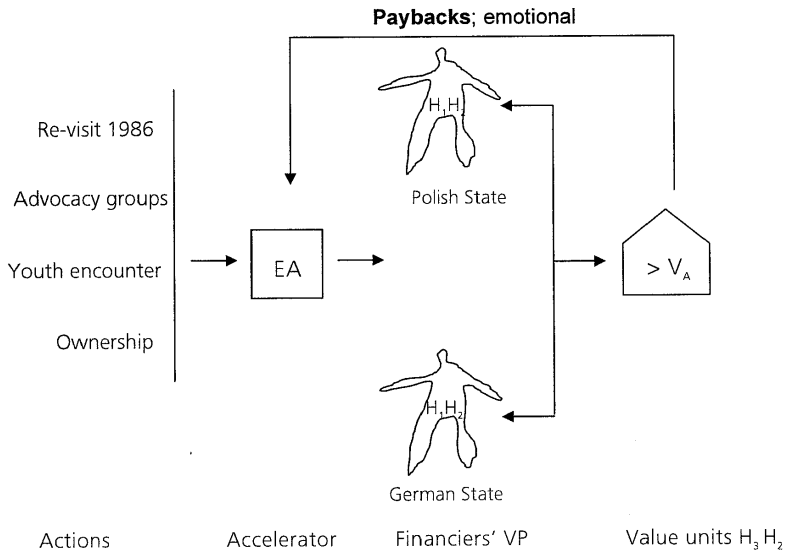

8824.2. The Kosciol Mariacki church restoration

The outline proposes the mechanism of funding of the Kosciol Mariacki project i.e. how two financiers (German and Polish State) reacted on four different actions, which sequentially stimulated their emotional accelerator to see values; their own VP, in the Kosciol Mariacki restoration. This gave the financiers a sense of guarantee that the outcomes of their funding commitment would be prosperous, by revealing its payback capacity for them. The financiers' certainty that they were right, in doing so, is what can stabilize value of built heritage like the Kosciol Mariacki Church.

The final examples of funding ventures added could signify that intellectual maps illustrating the action-accelerator-value process are definable outside the heritage sector as well and such maps might be of assistance for strategic funding planning.

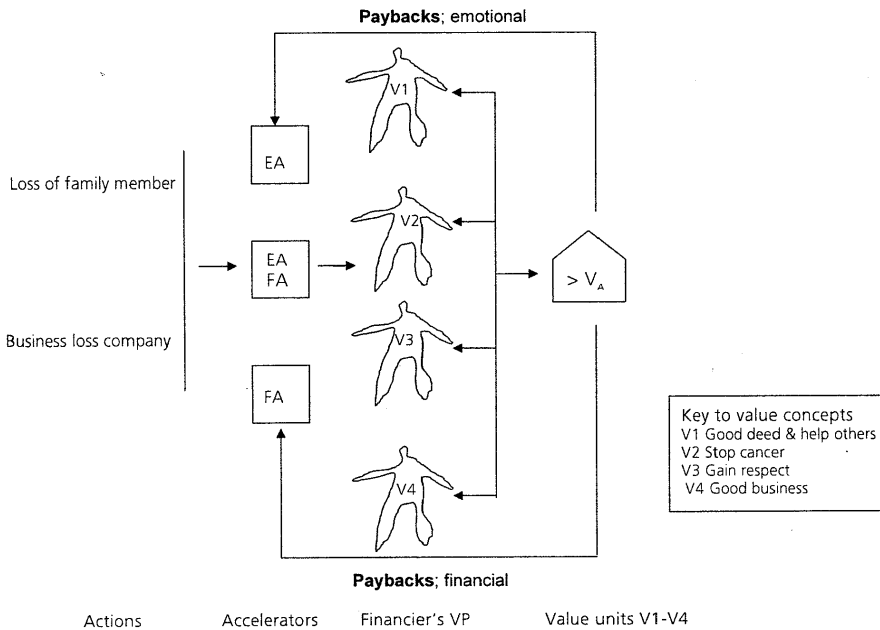

Figure 8824.3 A research centre

The proposed mechanism of funding outlined, describes a recent funding commitment made by a private person. The financier was investing and donating means to an insolvent cancer research centre in a university town, after a personal loss of a family member to the disease. The outline show how a private financier was reacting to different actions (personal loss and company failure), which in turn stimulated his emotional, mixed and financial accelerators to see values in the funding venture. The value concept, which have to be re-established, this time is evidently referring to the project's character, with; (V1) Do good/ Help others, (V2) Gain respect (V3) Stop cancer, (V4) Good Business. The way in which they are suggested linking to three combinations of accelerators (EA, EA/FA, FA) offer the financier a sense of guarantee that the outcomes of his funding commitment will be prosperous, by revealing its payback capacity. The financiers' certainty that he is right, in doing so, is what can make the value of the research centre stable. The example is intended to show that actions and accelerators are always constant, but for each project, new related value concepts have to be re-established consistently, for a initiating a funding commitment.

8.8.2.5 Could New Maglarp Church have been saved?

– Feeble accelerators put Swedish legacy at risk

Emotional and financial accelerators have been identified as the *keys* that induce heritage sponsors to rediscover even obscured values in the heritage. This verifies that to apply the model for acquiring, economizing and assuring of funding, these accelerators have to be acknowledged as well as endorsed. This very out-

come would also imply that when accelerators are ignored, then heritage funding would be inadequate. This correlation is unfortunately confirmed by today's conditions for built heritage in Sweden. However, this was not always the case and will therefore be possible to re-adjust.

The financially unsatisfying condition of built heritage sites in Sweden today, can be explained by a development nationally during the last century, which reduced the impact of accelerators. The feeble emotional accelerators were obvious in the Swedish projects as early as in Study 1, from the rather indifferent stance towards the built heritage in the conservation projects. Cases of building conservations registered in other countries, on the contrary verified every time a strong sentimental attachment. Emotional accelerators of built heritage were especially emphasized in nations which most recently had been exposed to turmoil in society⁵⁹ and repetitive threats from foreign powers, places which thus still possessed a war generation. Here heritage protection aimed not only at securing ancient constructions, but entailed a wide range of emotional ties to, or settlements with, the historical past which were also embodied in the legacy. Among the church preservations as of St. Jakobi church in Stralsund Germany, for instance, was just as much an emotional settlement committed to gaining mutual respect and to once more linking old and new Germans together. The Petri Church conservation revealed how the former secluded German community could reunite with the Danes and the city of Copenhagen. The Lutheran church restoration in Vilnius, unlocked the tense communication between Lithuania and Germany by re-establishing the church, which had been used as a basketball hall for 40 years. The Polish reconstruction of Kosciol Mariacki was also a reunion mission, where the disregarded and former ruinous German church could not only be resurrected, but also bridge a gap between countries on a local level.

In contrast to these ventures, the Swedish conservation of the Eslöv neo-Gothic church never evoked any emotionally charged disputes, linked to historical grounds. The conservation primarily concerned an aesthetical rearrangement of the interior setting, which had been changed over the years⁶⁰. Neither did the other two Swedish examples disclose any animated concerns in a social context, regarding ages gone by. The 200 years, which had spared Sweden from warfare, have most likely, reduced Swedish emotional bonds to history, in contradiction to the affectionate tangible or intangible concern, which the building protections evoked, in the neighbouring countries. The Swedish cases, since they were lacking any emotional accelerators, were characterized by a purely pragmatic and technically correct approach⁶¹. Strong emotional accelerators can thus be said to be inherited, but grow over time and will for this reason be sustainable since it is feasible these accelerators are passed on across generations.

This weak affection for Swedish built heritage; emotional accelerator, may also explain the lack of strong reaction against the systematic demolition of 40% of the historical city centres in Sweden in the 1960's. Functionalism at the Stockholm exhibition, just as the book *Acceptera*, inspired home policy to the ideologically set agenda for future Swedish cityscapes, where the built cultural heritage could not be integrated⁶². Moreover, since the Swedish National Heritage Board traditionally was superintended by archaeologists⁶³, who could have had an inflexible certainty, as regards heritage merely to advocate preservations in the legal framework, they therefore were in no position to prevent the destruction. This inflexibility not only excluded adapting buildings to another purpose as an option, but also excluded latent dialogue with the politicians. This elected group and laymen deciding on built cultural heritage matters, were primarily eager to display the increasing prosperity of the time and future optimism in society, with new constructions, which were meant to concretely visualize the Swedish welfare state⁶⁴.

The deadlock at the time, between politicians and authorities in heritage matters in a sense still prevails and the absence of external actions in the form of cultural threats, which repetitively have induced new protective guidelines including heritage funding in neighbouring countries, explains the present situation in Sweden. Neither of the two parties; politicians and heritage authorities, have therefore been forced to deal with or identify themselves with the other. The severe threat against built cultural heritage by warfare or other turmoil in society worldwide has proved necessary for collaboration, in order to establish new funding solutions. In Sweden the external incentives have been too faint to entice any re-organization, thus heritage funding by public grants still dominates. Today's lack of actions, such as finance incentives, for inducing the financial accelerators has its root in the centralized legal jurisdiction of public funding of the 19th century, which still prevails⁶⁵.

Industrialism and progressing wealth in society increased costs of manual labour and consequently building protection and it undermined the financial capacity of owners to heritage sites. Along with the built heritage being designated as historical landmarks by the authorities, public funding was improving. This still is the dominating source for inclined owners of cultural buildings to attain subsidies, adding to their own private capital, and sums available shift annually⁶⁶. Today's top-down funding verifies the absence of accelerators at bottom level, which thus obstructs acquisition of funding. The shortfall of incentives for establishing economical behaviours favourable for built heritage increases the public funding burden by excluding replacement funding from voluntary groups, which actually would have been free of charge. Politicians will at present scarcely gain votes by promoting solutions to meet local outbursts among single inhabitants for heritage protections, as emotional accelerators are in general very weak.

Consequently the financial budget plan for heritage funding does not include actions to stimulate financial accelerators to induce private financiers of built cultural heritage.

In spite of the early public heritage funding dominance, still some exceptions have been launched to encourage private investments. In the beginning of the 20th century for instance the collecting of private funding via private lottery funds was established for expensive theatre buildings⁶⁷ as well as for establishing the first historical museums. The initiator; national curator Sigurd Curman also managed to raise funding for building conservations nationwide⁶⁸. Private lotteries such as *Lotteriexpeditionen*, with the cultural sector as beneficiary, were later on nationalized and further on replaced by sports pools or tickets, which above all subsidise sport associations, other than the national budget. However, the privately funded heritage protection in Visby “Save the walls”⁶⁹ from the 1990’s, is a more recent extraordinary exception. The regular public subsidy for conservation measures of medieval constructions in the town, was suddenly cut and this was why local trade and industry stepped in as sponsors⁷⁰, but this time with the authorities as the active lobbyists. Though no tax concessions were available, local commitment proved to be sufficient for initiating private funding to protect the medieval Hanseatic stronghold of Visby. Cultural tourism was always essential for the Gotland region, but the project this time additionally initiated the annually celebrated “Visby days”. In spite of its inaccessibility as a town on an island, Visby has been most prosperous ever since. More investments have been made by the Swedish government to establish an education centre for all branches within cultural heritage⁷¹ in Visby and the major part of the Swedish antiquity board is now relocating in Visby from Stockholm as well.

The Allhelgona project, with the Brahe museum in 2005, in the same way, as at Visby, described the impact which financial accelerators have, when they have first been stimulated by external actions. Although this time the sources of finance were public, yet each party was governed by what potential output that could be gained, according to their value preferences of the church project, which usually signifies market economy of private funding. Pluralistic financier structure, uniting the two projects described, could include many value perspectives of built heritage and offered more sustainable multiple recourses of funding.

To solve increasing demand for resources, the Swedish heritage economics, management must adapt to the conditions of the 21st century. Politicians as well as the general public are obliged to get involved in cultural heritage issues just as heritage authority must begin to face economic reality. The less money there is to distribute, for conservation works, the more time consuming will the selection be, when choosing among the many qualified sites. Property owners, who are left with their rejected applications for subsidy, in this way might loose twice as they

still have to pay consultants preparing applications, whether subsidies are granted or not. Heritage funding based on public means alone for this reason is of an unreliable and costly nature. As the endowment depends on a single finance sources alone, in contradiction to the pluralistic private alternative, this moreover makes it vulnerable.

Top-down public funding and heritage jurisdiction has to come to an end. Instead new stronger financial incentives have to be implemented with capacity to bring local proceeds in as payback, as in the bottom-up situations, signifying private funding. Emotional initiatives, which manage to develop from the local level may have better chances of reaching our most vital target group for historic building legacy; the young people. In New York, Germany, Denmark this was solved by NPO's or foundations mediating configuration and in Great Britain by reorganizing the public body to become a semi-private heritage authority. In Norway and Finland public ear-marked funds and lotteries have been set up, to ensure available capital and an indirect funding form. Weak encouragement of the vital accelerators that as a result diminish the mechanism of funding, explains why only direct- and replacement funding can be acquired for heritage protection in Sweden, thus limiting the chances of successfully handling the growing finance deficit within heritage economics. Since both of them rely on varying cultural budgets in the annual finance plans, an introduction of indirect, credit and transmitted funding would most certainly be able to recover the inadequate finance situation.

Consideration could also be given on how much of Swedish building heritage that should be in public possession. New ownership forms may perhaps be discussed involving land remaining in public possessions, which is temporarily converted as leaseholds, whereas buildings are privatized. Germany just recently has been involved in equivalent matters, due to the reunion, and their experiences of this might be useful. Changes appear to reinforce emotional bounds to the three-dimensional history that built legacy represents. Economizing and assuring of funding, as proposed in the finance model, would then additionally be possible to apply. Bear in mind that Swedish cultural institutions of music and theatre buildings just as historic- and art museums from the 1880's to the 1930's would never have been feasible without the general public's whole-hearted support; and never worked relying merely on public funding. Why does today's society believe that its maintenance, reaching amounts equivalent to almost half of its initial costs, should only be paid for by governmental means?

Today's situation for heritage funding in Sweden is conceivably not intentional, but rather can be described as a stagnating heritage funding policy and for this reason contrasts to the ones practised in other nations studied. The exemplified New Maglarp Church could thus never have avoided demolition because fund-

ing deficiency still remains while emotional and financial accelerators are much too feeble in Sweden. However, unless existing funding conditions change, other built cultural heritage will see the same fate, whenever its values fail to transmit an imperative payback understanding to society. Yet history shows that appreciation for building legacy used to be far stronger than it is today and thus may easily regain its significance if suitably provided for.

8.8 Final conclusions

The purpose of this inquiry has been to analyse future prospects for augmenting fiscal resources for built cultural heritage to meet the growing deficits in heritage economics. The method employed has been to propose a value stabilizing and operational finance model based on case studies from practice. The major research question to be answered was;

How could an economically sustainable finance models be structured to meet the challenge called forth by the expanding built heritage sector? The initially assumed heritage finance model was set accordingly;

An operational finance model must ensure that finance (F) can be acquired (V_A), economized (C_{SAP}) through intentional distribution and assured (V_B) by achieving best possible future gain for the built cultural heritage.

Conclusions made from the study indicated that management of heritage economics consistent with the finance model procedure could be an answer for restraining the increasing finance deficit of built cultural heritage. However, to apply the model involves that the capacity of the accelerator be acknowledged and endorsed. Out of the four types discussed⁷² in the study, only emotional and financial accelerators have the capacity to induce financiers to rediscover temporarily concealed values in built heritage. The perception of values signifies that benefactors recognize building heritage's capacity for providing vital paybacks. This certainty increases and in this way stabilizes the values of built cultural heritage. For economic behaviour of funding to commence, these procedures as funding forms, are fundamental. Low value judgments lead in this way to devastating indifference and imply its fatal neglect of that built heritage. Emotional accelerators appear to be more complicated artificially to put in motion, since they represent inheritance collected over times past and they contrast for this reason with the more easily achievable financial accelerators. The proposed definition of built

cultural heritage, discussed in chapter 1, conveys in addition the significance of the two accelerators. When saying that *remembrance needs to be operational*, thus it involves emotional accelerators giving emotional paybacks and that built legacy *meets obligations set up by society* concerning accelerators of financial payback. In other words, the finance model will most likely augment fiscal resources in heritage economics since it is promoting *the value of notion*. The accelerators in this case become value regulators and consequently correspond to “the notion” in Thorsby’s statement⁷³, which was originally expressed; *In a fundamental sense the notion of “value” is the origin and motivation for all economic behaviour*. If applicable in practice, as required by the finance model, the expression needs to be transformed into the following expression; *In a fundamental sense the value of notion; the accelerator, is the origin and motivation for all economic behaviour*. Emotional and financial accelerators hence unfold vital human features in man and these are reinforced by the expected future dividend, which can be offered as paybacks of an intellectual or fiscal kind.

The accelerators’ ability to reveal values in heritage is stimulated by the external conditions, or *actions*, which depict built legacy so that citizens will notice its qualities, or values. Perception and awareness of value in building heritage is hence possible to positively adjust. Actions can either arise randomly at times in society, as in France in the 1790’s⁷⁴, or they can deliberately be established by means of marketing. For instance emotional accelerator refers to the human properties of curiosity and can be stimulated by the *action* of information, whereas the *action* of access may bring about a spirit of community. Anxiety emotions, which respond to the action of *threat* needs instantly to be settled and so the payback for the benefactor then, will be to re-gain the peace of mind. Threat, such as conclusive demolitions of historic buildings, is thus most efficient to apply so as to achieve quick reactions or results. Settling the personal properties of economical behaviour, or thrift, is encouraged by the action of *actual finance growth*, with the most tangible paybacks of all; the cash proceeds. The more competitive-natured *expected finance growth* has a strong impact on the economic behaviour which was seen in Holland during the *tulip trade* as early as during the 16th century, but also recently, one might say that tulips came as the *syntetic credits* for global financial service firms, until 2008⁷⁵.

Actions’ effect and success are guided by a financier’s own value preference (VP), which is why varied external encouragements have a better reach. This unique or personal set of values can additionally illustrate the spirit of the times, as seen during the European Heritage Year 1975. Benefactor’s actual economic conduct to act in favourable of built cultural heritage is expressed either as; direct funding, replacement funding, indirect funding, credit funding or transmitted funding, as mentioned above. Acquiring heritage funding entails that firstly, de-

liberate actions have to be induced and secondly the payback capacity of an economical behaviour or commitment has to be emphasized. This involves clarifying that beneficial conducts will be rewarded by conveying encouraging intellectual or financial returns. The weak accelerators in Sweden, which explain the inadequate heritage funding of today, could describe an ideological change to private benefactors, since the 1940's.

Values in built heritage can say to be persistent, but when or how society notice and describe them is shifting. Theoretical value concepts of so-called multi-criteria utilized by the heritage sector intended to establish values a set standard. Yet repeatedly this proved to have its limits as regards being put into practice, as the value benchmarks related at first only to small groups of European intellectuals⁷⁶. Globalization of the assignment to protect built cultural heritage has today made building conservation into a common responsibility financially, due to rising heritage threats⁷⁷. Incentives for acquiring heritage funding, which are regulated by built legacy's perceived rank of value, have proved to be inadequate for achieving value stabilization in practice, when encouraging only concepts in theory, as used in legal protection acts. Resulting demolitions, which took place nevertheless, especially of historical landmarks, clearly verify its inadequacies and listed buildings on the contrary became prime targets during warfare. Today, the issue of small exclusive groups in the heritage preservation debate and geographical borders of built heritage belong to the past. Written value criteria in legal acts, by politicians or investors involved in city renewals will for this reason never have the same clarity as originally intended⁷⁸. A "correct" interpretation of values, or *notion of value*, is thus most likely unrealistic to achieve and its utilization is certainly ineffective for funding enhancement, since this is always of a shifting nature, and thus endlessly definable. The most consistent value concept for practice has consequently to be re-established at the building site every time, since it is based on participants' cultural as professional capacity and contemporary description of value concepts with regards to time. Actions and accelerators rendering this funding process possible are however fixed since they represent the essence of human conduct and they will always be up to date, even across cultural barriers and periods of time.

I have in this doctoral thesis intended to prove that management of heritage economics, consistent with the finance model procedures, could be a way to restrain the finance deficits since the model is value stabilizing. The perception of values is fundamental for the model to initiate any economic behaviour. Theoretical value concepts of multi-criteria have its limitations, both to objectify and to quantify as a pecuniary worth. This is why I choose to approach the value issue by scrutinizing human conduct of funding, which is aligned with utility theories of economics, where individual consumer's preference or behaviour is ex-

plored. The H_3 UNS concept here established, on findings in practice and theory, was used a tool to describe the system vital for funding. In this so-called mechanism of funding, accelerators have the hub position and value is reflecting mental goals, which become stabilized if providing vital paybacks. The mechanisms of funding explain how financiers, when stimulated by external actions, can perceive values in building heritage as mental goals, which thus make them stabile, thanks to the emotional and financial accelerators. This signifies an awareness of built environment's ability to provide paybacks to financiers.

The re-modelled finance model to match the challenge of the rising number of built cultural heritage sites, for this reason has to be expressed as follows;

An operational finance model must ensure the accelerators' capacity to stabilize values in built heritage is endorsed as payback, thus enabling finance (F) to be acquired (V_A), economized (C_{SAP}) and assured (V_B) by achieving best possible future gain for society

Exploring the finance model structure has involved introducing new terminology into building preservation instigated by the idiom of economics. This new toolbox of definitions describing the process of heritage funding thus also links building conservation to economics. Terminologies crossing disciplines like a *lingua franca* will possibly improve contacts between stakeholders responsible for ensuring the building heritage. Easier communications among politicians, authorities, financiers and citizens, could make people realize how to contribute themselves. When even young people can see their roles, then much can be gained.

Heritage funding will never be sufficient, but this is not only for one generation alone to resolve. On the contrary, large capital investments in building conservation at one time hardly bring about the most considerable results, which the style purification movement confirmed in the 19th century. Instead, to avoid losing these irreplaceable building recourses, finance risks have to be spread out for restraining our time-reliant mistakes, which ensue in all conservations. Funding provides a chance to get involved and be committed, whereas indifference is building legacy's greatest threat. All generations have thus to contribute to its protection so our built cultural heritage; three-dimensional images of the past, will be part of every society, not as museum exhibits, but as dynamic culture assets.

"...the buildings of past times.." "... We have no right whatever to touch them. They are not ours. They belong partly to those who built them, and partly to the generations of mankind who are to follow us..." "...What we have ourselves built, we are at liberty to throw down; but what other men gave their strength,

and wealth and life to accomplish, their right over does not pass away with their death...” (John Ruskin, 1880 “The Lamp of Memory”)

8.9 Future research

Ever since the UN World Commission on Culture and Development in 1995⁷⁹ confirmed the vital impact of build cultural heritage on economic progress, the general consent is that protection of building heritage would actually be a useful tool for development strategies in third world countries. This means that building conservation today clearly has gained a more prominent position, since being recognized as one of the fundamentals of culture that can stabilize societies, in the struggle against poverty. For this reason the World Bank is already integrating restoration of historic properties in the lending strategies for developing economies. Nevertheless, more intercontinental heritage funding is called for and this is why an improved understanding among beneficiaries and benefactors of, for instance, the mechanism of funding, might contribute to making a more efficient use of the finance means available.

The global allocation of heritage funding to regions for instance struck by nature catastrophes, such as Haiti recently hit by a devastating earthquake, will involve crossing cultural barriers every time. The absence of a common cultural context for this reason will always disclose the need of a mutual cultural frame of reference, or value preferences, when selecting what building legacy to preserve, which may obstruct an efficient use of funding. With the ambition of adapting the heritage finance model for a future apply; case studies in regions suddenly hit by nature catastrophes could therefore be a future research field. This is because the model emanates from analyses of existing condition in practice, where improvements of communicating values; how goals among parties involved could reveal paybacks, is called for. The findings might become useful for stakeholders engaged in future funding commitments by reducing impediments since investigating local conditions for conservation projects, in relation to the financiers' intentions. The finance model could in this way assist building preservation planning regarding acquiring, economizing and assuring a trans-frontier heritage funding. A well-organized financial support effort, launching building conservation programs would provide the necessary resources that may assist developing countries to progress by means of their own built culture heritage, consistent with the UN Commission.

A successful conservation programme that has encouraged a local social-, cultural- as well as economical development, which could be of guidance, is for

example Darb al-Ahmar in Kairo a previously rundown residential district, sponsored by the Aga Kahn Historic City Program. The project management was here organized by means of close contact between financiers and local citizen groups. This organization form most likely explains its degree of success and underlines the significance of a good dialogue between all parties. In the Cairo project this was facilitated since the parties had a mutual cultural frame of reference to begin with.



89.1 *The Darb al-Ahmar in Kairo in the Aga Kahn Historic City Program*

Absence of a common cultural context, which often characterises the international financial aid programs, can for this reason be a lingering predicament. The endowments will in this case always be crossing cultural barriers and so reveal diverse heritage value recognitions, which often affect funding allocation negatively. That value preferences are already diversified between different professional groups or financiers, as discussed in the study, explains why international heritage advocacy can hardly be described as resting on identical value grounds. Reducing impediments would therefore involve scrutinizing the mechanism of funding by mapping local conditions involving; heritage values, its enhancement potentials and payback options. These would then be set in relation to presumptive financier and beneficiary groups, so as to enable a heritage funding and its assurance. Here the Heritage Finance Model approach could contribute in bridging the existing cultural gaps by exposing the parties' individual, just as their shared, value preferences.

Heritage funding and investment required for the redevelopment of Haiti, unfortunately for the next decade to come, in this case could provide an opportunity to test the capacity of the heritage finance model. In the coming decade interna-

tional capital will be allocated for the country's redevelopment where resurrection of the ruined built cultural heritage shall also play an important part since it is recognized to be vital for stabilizing society. Today World Heritage Fund (WHF) and World Monuments Fund (WMF) are among the largest financiers of building conservation on the international stage; however their modus operandi is different. The WHF traditionally has more of a top-down structure in their project funding, whereas the strategy the WMF, which is relying more on the local heritage advocacy, can be categorized as bottom-up. A reverent funding approach might enable a more humble and respectful procedure in selecting historic buildings with the best capacity to induce renewed hope to a community, a strategy which might not always coincide with the buildings recommended for heritage protection from the perspective of international financiers. This more modest approach might entail the most prominent building having to wait, in favour of those more available to public, which actually have better chances of encouraging a contextual asset growth locally. Other financiers will perhaps influence the approach of the building conservations applied and so all involved actors need to be considered, just as do their funding forms, whether direct, indirect, credit, replacement or a transmitted funding⁸⁰. Initially the heritage model could be applied for analysing the present funding in practice, to suggest possible heritage finance guidelines. As a second step these outcomes might be applied in practice on a minor conservation project.

New experience gained could thus be of use as a development strategy for growing economies in building preservation ventures, by improving efficiency for communicating the mechanism of heritage funding. For regions struck by nature catastrophes findings from the research field of *Development Economics*, and studies with a Haiti focus by Professor Mats Lundahl⁸¹ who is a master of the international perspective, would be vital as guidance. In a mixed team of anthropologists, economists, historians, engineers and architects the following finance model could be tested with the intention to become tailor-made for fitting international heritage funding, since it is based on actual conditions in developing economies. A finance model based on existing conditions entails the following five parts;

1. Analysing the heritage economics in practice:

Investigate the action- accelerator-value relation from a past development perspective of relevance for obtaining the logical actions needed to trigger the mechanism of funding.

2. Assume a temporary finance model with the presumed capacity for acquiring, economizing and assuring funding.

3:1 Acquiring funding; make addition and subtraction adjustments of the H₃UNS concept to attain an agreeable value template based on interviews with all parties on the bottom-, middle- and top levels⁸².

- 3.2 Analyse the characteristics of values and subdivide into enhancement potentials for establishing the relations to emotional and financial accelerators. Outline the actions-accelerators and value perspective; the acquisition of funding (V_A); value activating funding.
- 3:3 Study the financer groups by using the OMAS format to establish the individual value frame of reference; the value preference (VP), owing to origin (O) and methods (M) applied.
4. Economizing and assuring funding; relevant intentional distribution of building phases and ensure that use and building measures bring dividend.
5. Set up a new finance model for future use, based on the result of the findings.

Notes chapter 8

1. For instance demolitions, involving cultural and financial losses, chapter 1 and chapter 8.
2. Such as development strategies in the LDC's, the least developed countries in the third world. These issues were discussed in Stockholm 1998 and Faro in 2005 as well, see chapter 1.
3. See earlier discussed examples from London, New York or Stockholm, chapter 1.
4. Half of the restoration expenses were paid for by private capital, see chapter 1.
5. Sales minus costs equal profits see chapter 2 and Finance model (2008, Web).
6. The empirically based value model, HUNS, was restructured according to how the value concept had been applied in a chronological outline. This refined value theory is the H₃UNS concept.
7. See chapter 2.
8. Consistent with the written guidelines in the national heritage protection acts.
9. All private owners have to contribute and the heritage funding discussed in this study is the additional capital required.
10. See Halland Model or Tradition and Building Production, chapter 5.
11. Such as getting state control over the black labour market or implementing energy-saving measures on historic buildings.
12. Easements, bonds or portfolios of shares with buyback programs, see chapter 6.
13. These actions, of actual or expected finance growth, stimulate the NPO's value perception of built heritage (nominal value).
14. Publicly funded advocacy groups could be possible to control, since they rely on this income and could also loose their free spirit and vitality, which signify the grass root groups.
15. Private funded projects verified to be brief, included all buildings categories, they accepted adaptation for new use and aim to do the job. Public funded project in many ways were their contradiction, Appendix 1.
16. Local consultants and craftsmen are in this way exposed to an unjust competition. On the contrary, when local businesses practicing building conservation, instead could be offered economical benefits in times of financial recession, such as tax-concessions, new jobs could be created. In this way a local and regional professional re-growth would be ensured. Local companies feel strong commitment to regional assignment, they have lower expenses and the employment brings value increase for historic buildings, see chapter 2.
17. Reducing the chances for value growth of built legacy with fewer financiers as well as the chances to encourage youth.
18. Eliminating the incentives of economizing funding, this is for example; for consultants to reduce their commission fee become irrelevant since they have already been selected since "certified".
19. Projects funded equally much by private and public capital, were corresponding to the market principles.
20. The assigned consultants and craftsmen are replaced, when they are unable to compete with lower commission fees. This approach can at times be unfavourable since conservation measures are often long-lasting.
21. NGO's such as the The Red Cross, World Wide Fund of Nature and Greenpeace.
22. See chapter 6.
23. Trusts, Foundations, NPOs, Advocacy groups, Finance market, Lotteries and Donors. Trusts are the exclude since they do not allocate any external funding. Public funding is presented as two parted; politician (P) and authority (A).
24. Information is fundamental for any value growth, which is why value parameters will always expand when more knowledge or experience is at hand, see chapter 3.

25. Value inventories and assessment such as those by Fielden, Riegle or the H₃UNS concept, will be vital instruments if their information content will be made public available on the Internet or at local libraries and not only stored in archives. Inventory survey models, developed to be used by untrained professionals on building sites, such as the Fischer's Raumbuch can fulfil this purpose. This building inventory tool from the 1990's was designed by the German restoration architect Konrad Fischer. The tool is based on a pre-set checklist of likely damage conditions which are likely appear on old constructions and suggestion appropriate measures to take. The comprehensive damage inventory Fischer's Raumbuch has proved to be most efficient for economizing heritage funding; that is cost reductions, see Fischer (2007).
26. The additional funding of historical groups, such as the BPT model in UK, might build up companies, which is not intended here.
27. Equivalent to the French Rampart camps.
28. The book „Katechismus der Denkmalpflege“, see chapter 3.
29. See Stein 1977, chapter 1.
30. First of all for skilled craftsmen, apprentices or consultant firms within building conservation field, and secondly, for the local hotels, restaurants and shops.
31. Banks or insurance companies.
32. New York Landmark Conservancy and Realdania are both good role models, chapter 4.
33. Out of the financiers, a majority, all except one, was induced by the financial accelerator.
34. This could be visits with guided tours, lectures, publications and souvenirs.
35. Alterations with modern materials on the contrary, could thus decrease the nominal value on historic buildings, since they are based on non-empirically tested fabric in outdoor conditions and therefore they may generate new expenses, since they could be incompatible and have to be re-made.
36. Establishing the external condition required, that is *actions* of; access, information or actual/expected finance growth (tourism or employment).
37. Interest rate increases from credit funding, such as easements, portfolios of shares in historic buildings combined with buybacks or low-risk municipal bonds.
38. Its many advantages are exposed for all citizens through marketing, see definitions chapter 3.
39. In spite of the good intentions to ensure built cultural heritage, with legal acts and listing, even the once most respected buildings have been demolished.
40. Detailed value expressions could easier be misinterpreted, thus they might be dismissed. More generalizing valuation terms have capacity to include more and wider interpretations.
41. Direct funding, replacement funding, indirect funding, credit funding and transmitted funding.
42. This was most obvious as the advocator for the demolition was a younger Christian Democrat politician (Mats Svensson, KD) and among the few opposing the destruction was a senior politician, representing the Social Democratic Party (Egil Ahl, S), Nilsson, A. (2007).
43. Only the last five years the cost increase was 25 million SEK, calculations by Architect H. Ponnert, see chapter 1.
44. Quotation from the interview with the architect in charge for the St Jacobi Church restoration, Zülch (2009, interview).
45. See chapter 7.
46. Sysaw is a communal incineration plant and it is cooperatively owned by the municipalities in the region. The Maglarp's bricks were re-used for the company's new Visitors Centre and the company's choice to use re-cycled brickwork from the demolished New Maglarp church, can be said to have supported their "green" image.
47. *Stavstensudde* and *Maglarp Strand*, project plans at the Trelleborg municipality.

48. The additional expenses were project planning, demolition, transport of bricks, cleaning and reuse. The three cost calculation should be added, 1992, 1999 and 2004 and finally the lawsuit expenses (1996-2005).
49. The plans for the demolition of the Örja church built in 1868, have been discussed since 2003, Nyström (2009, interview).
50. Sweden joined the European Union as a member of in 1995.
51. The church was sold for the symbolic sum of one Swedish Crown, Nyström 2009.
52. This could also be a gesture in favour for local prosperity and good will for church activities.
53. See Skarin Pålsson (2001, Bilaga 19, p. 287).
54. Tax exemptions, see chapter 5.
55. The German Architect Günter. Kumkar, born in Choinia, which was Königsberg until 1945.
56. Public as Federal funding from Poland and Germany.
57. Ecumenical services were celebrated as soon as the church was covered with a roof.
58. The compulsory transferred Poles came from eastern Poland which became Lithuanian after 1945, Wolender (1997, interview).
59. Poland, Lithuania and former East Germany.
60. The original colour layers from 1891 were rejected by the Parish Council in favour of a later interior appearance, which was more agreeable for the council members, thus approved.
61. The other two Swedish conservation projects were The Chinese pavilion, at Drottningholm, and The Blekinge farmhouse at Kulturen open air museum. The Chinese pavilion represented in some way an exception, with its detailed and technical advanced conservation measures, but it was lacking an emotional-historical significance. The prime target was to ensure that the site would live up to its position on the World Heritage List and for this purpose the funding was adequate, see Skarin Pålsson (2001, p. 199) and note 5 chapter 7.
62. During 1960-70 more than 40% of the historic city centres were demolished. See Johansson (1997, p. 11). Asplund et al (1980, p. 47ff) The Stockholm Exhibition 1932.
63. Inger Liliequist National Curator in 2003-, Erik Wegraeus during 1993-2003 and Margareta Biörnstad from 1987 to 1993 are all archaeologists.
64. *Folkhemmet* in Swedish.
65. Once inspired by the French Classements. The public body for heritage protection set up in the 1880's when the historical groups of archaeologists, historians and conservators, grew strong since they were unified by their common disapproval of the style purification movement, see chapter 1.
66. RAÄ (2005, p. 78ff), Sjö, B (2003) and Söderberg (2004).
67. The Dramaten theatre in Stockholm was once built thanks to the funding which came from lotteries and in 1908 7 millions SEK were made available for the 6,5 million project, Hutz (2004, p. 176) and Dramaten (2009, Web) Today the cultural sector rely on public grants alone, see chapter 6.
68. The historical museum in Stockholm and church preservations brought 5 million SEK in 1927, SOU (1965:10 p. 35f), which would correspond to 125 millions in 2007 currency value, Myntkabinettet (2009, Web) and the creation of Malmö Palace of museum by the renaissance castle, in 1932.
69. Visby City medieval defence wall during, conservation during five years.
70. See "Visby Ringmur" (1991), Bidrag till kampanjen "Rädda Visby Ringmur!" (1991), Sponsoravtal (1990)
71. Gotland University; . Cultural Heritage department (Högskolan på Gotland; Kulturmiljövård) and The Museum of Gotland, Fornsalen.
72. Emotional, financial, political and obligation accelerators.

73. Quotation by Throsby (2004, p. 19).
74. See chapter 3
75. See chapter 6.
76. Individual, who were by society at the time considered sufficiently competent to distinguish its significance.
77. Wars, city redevelopment or pollutions.
78. The value definitions became far too theoretical to be applied as guidelines in real-life conservation projects for professionals, stakeholders and financiers.
79. The World Commission on Culture and Development Report (1995, p. 24f and p. 206f)", see Throsby (2004, p. 67).
80. The Credit funding coincide with how today's international finance market work, where nations regularly set up national bodies to attain international capital.
81. See Lundahl (1995) and, Lundahl and Nudulu Benno J (1996).
82. Local domestic level, international financier and the public body.

Summary

The new role of built cultural heritage, as an economic asset for development strategies, as was proclaimed by the United Nations in 1995 and the widened definition of built cultural heritage as a concept-, explains the rapid increase in the amount of what is defined today as indispensable global heritage. However, this highly-regarded affluence of built heritage sites can only be guaranteed when those sites receive regular maintenance, which naturally requires sufficient funding. This predicts an inevitable growing finance deficit in the area of heritage, especially as this deficit is already critical internationally, because costs are also increasing. Financers' inducement to fund cultural heritage depends on that heritage's current value estimation and only highly revered sites qualify for support. Case studies illustrate how corresponding churches can meet different fates owing to dissimilar external conditions and circumstances surrounding them. This implies that values are incessantly present in the built cultural heritage and so the level of respect with which a heritage site is viewed, can be re-established when the right external conditions, or actions, arise. The assessment thus reflects the human perception of values projected onto buildings and is not caused by the physical characteristics of the heritage itself. This is way it is possible to modify finance incentive conditions.

The present lack of sufficient funding inherent in heritage economics proves that finance models are needed in order to assist in management of building protection, but prototypes of such finance models are lacking. Cultural economics addresses the topic of cultural value as a means of improving investments. This inquiry aspires to supplement these findings, but from the viewpoint of actual building conservation practice. The aim of this doctoral thesis is to investigate the prospects of securing the successful future of built heritage by proposing a value stabilizing finance model, based on; the acquiring, the economizing and the assuring of heritage funding.

The strategy of this inquiry involves five steps; analysing heritage economics in practice (1), assuming a value stabilizing heritage finance model (2), acquiring funding (3), economizing funding (4) and assuring funding (5). The empirical field observations of the first step were based on interviews from 27 building conservation projects in eight European countries. Qualitative and quantitative methods were here complemented with new graphics to clarify focus patterns. The data from interviews and the methodology were also later employed in this

study. Secondly, based on these findings, a value stabilizing finance model was developed and expressed as arithmetic variables, using and re-modelling a template from the field of economics. The third step concerned the acquisition of funding and how to settle the mechanism of funding as a tool to be employed systematically for exploring private, public and alternative financiers. The fourth step regarding the economizing of funding refers to the distribution or staggering of expenditures in building conservation work. The fifth step, entailed aspects for assuring the future of funding by nourishing the mechanism of funding itself and taking measures that were constructionally resilient.

Emotional and financial accelerators proved to determine all economic interventions of the heritage finance model, since it is the accelerators which stabilize the value of the built environment by revealing the payback capacity of a financial commitment. Financial accelerators are easier to launch while emotional accelerators are typically inherited, but the emotional aspect can cause financial accelerators to rise. Heritage funding in Sweden has stagnated whereas finance policy in the other nations in this study, has progressed. This is due to the nationally weak emotional and financial accelerators in Sweden, which mean built heritage is at risk of falling into decay. Private finance incentive, which is required from now on, can only be efficient if indirect funding is nationally approved and completely new options for providing alternative funding were to become possible by including credit funding in governments' heritage finance policy.

The suggested contribution of this inquiry is the exploratory analysis of the mechanisms behind heritage funding including its accelerators, hence introducing new terminology into building conservation instigated by the idiom of economics. Crossing disciplines could improve contact between the stakeholders accountable, thus aspiring to ease future policy decisions and future strategic planning of heritage funding.

References

Published literature

- Aspromourgos, T., 1996, *On the Origins of Classical Economics. Distribution and value from William Petty to Adam Smith*. Routledge, London.
- Alexander, C., 1975, et al *The Oregon experiment*. Oxford University Press, New York.
- Antell, O.(ed) et al, 1991. *Nygotiska kyrkor i Skåne: utveckling i form, material och konstruktion 1840-1910*, Konsthögskolan, Arkitekturskolan, Stockholm.
- Asplund, G., Gahn, W, et al (1980), *Acceptera*. Berlings, Arlöv.
- Bacher, E., 1995, *Alois Riegl. Kunstwerk oder Denkmal? Alois Riegls Schriften zur Denkmalpflege*. Böhlau Verlag, Wien.
- Barup, K. & Edström, M., 1990, *Skärva. Isensättning av ett lantställe*. Byggförlaget, Stockholm.
- Berger, L. & Luckmann, T. 1991, *The Social Construction of Reality*. Penguin Books, London.
- Björklund, K. (ed) & Ekwall, Å., 2003, *Fastighetsekonomisk analys och fastighetsrätt, Fastighetsnomenklatur*. Fastighetsnytt Förlag AB, Stockholm.
- Bogdan, M., 2003, *Komparativ rättskunskap*. Nordstedts juridik, Stockholm.
- Boorsma, P. B.(ed), van Hemel A.(ed) & van der Wielen N.(ed), 1998, *Privatization and Culture. Experiences in the Arts, Heritage and Cultural Industries in Europe*. Kluwer Academic Publisher, Dordrecht.
- Burnham, B. 1997, *Heritage Conservation in the United States: Law as an Incentive for Private Initiative*, pp.85-88. Legal structures of private sponsorship, International seminar in Weimar, German National Committee of ICOMOS. Karl. M Lipp Verlag, München.
- Byström, H., 2007, *Finance. Markets, Instruments & Investments*. Studentlitteratur, Lund.
- Clawson, M. (1959), *Method for Measuring the Demand for, and Value of, Outdoor Recreation*. Resources for the Future,10, Washington DC.
- Clark, J. B., 1899, *The Distribution of Wealth. A Theory of Wages, Interests and Profits*. The Macmillan Company, New York.
- Creigh-Tyte, S., 1998, *Mixed Economy and Culture*.pp.183-197. Privatization and Culture. Experiences in the Arts, Heritage and Cultural Industries in Europe. Kluwer Academic Publisher, Dordrecht.
- Creigh-Tyte, S. (1998) pp183-195 Mixed economy and culture. Privatization and Culture. Dordrecht, The Netherlands.
- Dehio, G. (1905), *Denkmalschutz und Denkmalpflege in den neunzehnten Jahrhundert*, speech in Strassburg
- Denslagen, W. ,1994, *Architectural restoration in Western Europe: controversy and continuity*. Architectura & Natura Press, Amsterdam.
- Dillard, D., 1997, *Västeuropas och Förenta staternas ekonomiska historia*. Gleerups förlag, Malmö.
- Dvorák von, M.,1916, *Katechismus der Denkmalpflege*. Rudolf M. Rohrer, Brünn.
- Eriksson, T. L. & Wiederheim-Paul, F., 1991, *Att utreda, forska och rapportera*. Liber Ekonomi, 1997.
- Eklund, K., 1995, *Vår ekonomi. En introduktion till samhällsekonomi*. Tidens förlag, Sweden.
- Feilden, B.,1982 , *Conservation or Historic Buildings*. Butterworth-Heinemann, Oxford 1994.
- Fernlund, S., 1982, "ett herranom ovärdigt tempel" *Kyrkorivningar och kyrkobyggen I Skåne 1812-1912*. Konstvetenskapliga Institutionen, Lund.

- Fischer, K., 2007, *Altbauten kostengünstigen sanieren. Die Strategien des Planens und Bauens in Bestand*. Gentlemen's Digests Ltd & Co.KG, Berlin.
- Fusco Girard, L. (ed) & Nijkamp, P., (ed) 2010, *Cultural Tourism and Sustainable Local Development*. Ashgate, Farnham.
- Goethe, J. W., 1981, *Die Wahlverwandtschaften*. Insel Verlag, Frankfurt am Main.
- Gustafsson, C., 2009, *The Halland Model. A Trading Zone for Building Conservation in Concert with Labour Market Policy and the Construction Industry. Aiming at regional Sustainable Development*. Chalmers University of Technology, Göteborg.
- Hayek, F.A., 1999, *The constitution of liberty. Frihetens Grundvalar*. Laurence Hayek & AB Timbro, Stockholm.
- Hellström, J., 2008, *Non-Invasive Monitoring of Architectural Heritage. Remote Fluorescence Lidar Imaging*. Lund University, Lund.
- Hidemark, O., 1998, *Kina slott vårda och bevara*. Byggförlaget. Stockholm.
- Hondius, F. W., 1997, *Foundations*, pp.16-21. Legal structures of private sponsorship, International seminar in Weimar, German National Committee of ICOMOS. Karl. M Lipp Verlag, München.
- Hotelling, H., 1949, , Letter, In: *An Economic Study of the Monetary Evaluation of Recreation in the National Parks*. National Park Service, Washington, DC.
- Hunter, M. (ed) et al, 1996, *Preserving the past. The Rise of Heritage in Modern Britain*. Alan Sutton Publishing Limited, Great Britain.
- Huse, H., 1996, *Denkmalpflege. Deutsche Texte aus drei Jahrhunderte*. Verlag C. H. Beck, München.
- Hutter, M. & Throsby, D. ,2008, *Beyond Price. Value in Culture, Economics and the Arts*. Cambridge University Press, New York.
- Hutz, O., 2004, *Drömmars Värde*. Stockholms Universitet, Gidlunds Förlag, Stockholm
- ICOMOS- Nationalkomitee der DDR, 1984, *Denkmale und kulturelle Identität*. VEB Verlag für Bauwesen, Berlin.
- ICOMOS, 1997, *Legal structures of private sponsorship, International seminar in Weimar*, German National Committee of ICOMOS. Karl. M Lipp Verlag, München.
- Johansson, B.O.H. ,1997, *Den stora stadsomvandlingen. Erfarenheter från ett kulturmord*. Kulturdepartementet/Nordstedts, Stockholm.
- Jokilehto J. I., 1986, *A history of Architectural Conservation. The Contribution of English, French, German, and Italian Thoughts toward an International Approach to the Conservation of Cultural Property*. The University of York, York.
- Jonsson, M., 1976, *Monumentvårdens begynnelse. Restaurering och friläggning av antika monument i Rom 1800-1830*. Almqvist & Wiksell International, Stockholm.
- Kaplan, A., 1964, *The conduct of inquiry: Methodology for Behaviour Science*. Chandler Publishing Company, San Francisco.
- Kearns, P., 1997, *Monuments in the Law of Trust*, pp.21-23. Legal structures of private sponsorship,
- Kulturminneslagen, Nyström Kronberg, E. (ed), 1991, *Byggnadsminnesförklaring. Allmänna råd till kap 3. lagen om kulturminnen m.m*. Riksantikvarieämbetet, Stockholm.
- Kowalski, W, 1997, *Legal Structures of Public Participation and the Protection of Cultural Heritage in Poland*, pp.70-72. Legal structures of private sponsorship, International seminar in Weimar, German National Committee of ICOMOS. Karl. M Lipp Verlag, München.
- Kåring, G., 1992, *När medeltidens sol gått ner*. Debatten om byggnadsvård i England, Frankrike och Tyskland 1815-1914. Konstvetenskapliga Institutionen, Stockholms universitet Stockholm
- Lanz, A., 1993, *Intervjumetodik. Den professionellt genomförda intervjun*. Studentlitteratur, Lund.
- Landström, H. (1987) *Utvecklingsförlopp och finansiellt handlande i unga innovationsbaserade företag*. Institutionen för industriell organisation, Tekniska högskolan, Göteborg.
- Landström, H., 2000, *Entreprenörskapets rötter*. Studentlitteratur, Lund.

- Lindqvist, K., 2003, *Exhibition Enterprising*. Stockholm University School of Business, Stockholm.
- Lundahl, M., 1995, *Regleringar, marknader och ekonomisk utveckling*. Studieförbundet. Näringsliv och Samhälle (SNS), Stockholm.
- Lundahl, M. (ed) & Ndulu, Benno, J. (ed), 1996, *New Directions in Development Economics: growth, environmental concerns and government in the 1990s*. Routledge, London.
- Marston Fitch, J., 1998, *Historic preservation. Curatorial Management of the Built World*. University Press of Virginia, Charlottesville & London.
- Mellander, C., 2008, *The Wealth of Urban Regions*. Jönköping International Business School, Jönköping.
- Mousette, S., 1997, *Sponsorship and its Legal Forms in France*. Legal structures of private sponsorship, International seminar in Weimar, German National Committee of ICOMOS. Karl. M Lipp Verlag, München.
- Moyo, D., 2009, *Dead Aid. Why Aid is not working and how there is another way for Africa*. Penguin Books, London.
- Mårtensson, B. & Nilstun, T., *Praktisk Vetenskapsteori*. Studentlitteratur, Lund.
- Peacock, A. and Rizzo, I., 2008, *The Heritage Game. Economics, policy and practice*. Oxford University Press, Oxford.
- Petzet, M. & Mader, G.T., 1993, *Prachtische Denkmalpflege*. W. Kohlhammer, Germany.
- Pevsner, N. (1978), *An Outline of the European Architecture*. Penguin Books, England.
- Quinn Patton, M., 1987, *How to Use Qualitative Methods in Evaluation*. University of California, Sage Publication, London.
- Ritter von Srbik, H. H., 1997, *The Messerschmidt Foundation*. Legal structures of private sponsorship, International seminar in Weimar, German National Committee of ICOMOS. Karl. M Lipp Verlag, München.
- Rosengren, K. & Arvidsson, P., 1992, *Sociologisk metodik*. Almqvist & Wiksell Förlag, Falköping.
- Ruskin, J., 1989, *Seven lamps of Architecture*. The Dover Publication, New York.
- Ruskin, J., 2010, *Munerva Pulveris; Six Essays on the Elements of Political Economy*. General Books, Memphis.
- Schuster, W., 2000, *Finansiella planeringsmodeller med datorstöd: en praktisk ansats*. Studentlitteratur, Lund.
- Schwanborg, I., 2002, *Kulturbeskrivning och bedömning av kyrkor*, Riksantikvarieämbetet, Stockholm.
- Scitovsky, T., 1976, *The Joyless Economy. An Inquiry into Human Satisfaction and Consumers Dissatisfaction*. Oxford University Press, New York.
- Skarin Pålsson, I., 2001, *Byggnadsvård kring Östersjön – en studie av arbetsprocesser med fallstudier från Litauen, Polen, Tyskland, Danmark och Sverige*. Lunds Universitet, Lund.
- Smith, A., 1999, *The Wealth of Nations. Books I-III*. Penguin books, London.
- Stanley Price, N. (ed), Kirkby Talley jr, M., Melucco Vaccaro, A., 1996, *Historical and Philosophical issues in the Conservation of Cultural Heritage*. Getty Conservation Institute, Los Angeles.
- Stein, R. G. and Partners Architects., 1977, *Proposal in response to Department of the Interior*. RFP-14-01-0001-77-R-25, August. See Marston Fitch (1982/1998, p. 33).
- Stenström, E., 2000, *Konstiga företag*. Handelshögskolan, Natur och Kultur Stockholm.
- Steiner, C., 1997, *The J. Paul Getty Trust*. Legal structures of private sponsorship, International seminar in Weimar, German National Committee of ICOMOS. Karl. M Lipp Verlag, München.
- Svala, C., 1990, *Lantbruksarkitekten Charles Emil Löfvenskiöld*. Sveriges lantbruksuniversitet, Alnarp.
- Svenska Unesco (1993) Konvention om skydd för världens kultur och naturarv. 2/1993 Stockholm.

- Throsby, D., 2001, *Economics and Culture*. Cambridge University Press 2004. The United States 2004.
- Throsby, D., 2010, *The Economics of Cultural Policy*. Cambridge University Press, Cambridge.
- UNESCO (1994) Information as and Instrument for Protection against War Damages for the Cultural Heritage. Report from seminar ICOMOS. Stockholm
- Trützscher von W., 1997, *Foreword*. Legal structures of private sponsorship, International seminar in Weimar, German National Committee of ICOMOS. Karl. M Lipp Verlag, München.
- Unnerbäck, A., 2003, *Kulturhistorisk värdering av bebyggelse*. Riksantikvarieämbetet, Stockholm.
- von Goethe, J. W., 1809, *Die Wahlverwandschaft*. Insel Verlag 1981, Frankfurt am Main.
- Vitruvius, 2008, *The Ten Books on Architecture*. The Echo Library, Teddington.
- Wang, D. & Groat, L., 2002, *Architectural Research Methods*. John Wiley and Sons, New York.
- Wetterberg, O., 1992, *Monument och miljö. Perspektiv på det tidiga 1900-talets byggnadsvård i Sverige*. Chalmers Tekniska högskola. Graphic System AB, Göteborg.
- Zettervall, H. and Callmer, C. (ed), 1981, *Något om mig själv. Självbiografiska anteckningar*. Kungliga biblioteket, Stockholm.

Reports, Articles, Papers and Brochures

- Acemogly D., 1993, *Learning about Other's Actions and the Investment Accelerator*. Economic Journal, Royal Economic society, vol 103 (417), March pp. 318-328.
- Anderberg, J., 2009, *Fakta; utan mellanhänder P2P*. Sydsvenska Dagbladet, 090729 Malmö.
- Arestis, P., Luintel, A. D. & Luintel, K.B., 2005, *Financial Structure and Economic Growth*. CEPP working paper no. 06/05. University of Cambridge, Cambridge.
- Baumol, H. & Baumol, W., 2002, *Maledizione! Or the Perilous Prospects of Beethoven's Patrons*. Journal of Cultural Economics 26: 167-184.
- Black, B. & Gilson, B. 1998, *Venture capital and structure of capital markets*. Journal of Financial Economics 47, 1998, pp. 243-277.
- Braw, E., 2007, *Honorärkonsul profilerar Sverige i San Francisco*. Sydsvenska Dagbladet, 070610, Malmö.
- Bosson, A., 2008, *Gåvor till Lund Universitet urholkas av avgifter*. Sydsvenska Dagbladet, 080601; Malmö.
- Cannon, J., 2004, *Changing Places. What the historic environment can do for the 21st century England*. English Heritage, London
- Changing London, 2002, *An historic city for a modern world*. English Heritage, Wordsearch, London
- Coeterier, J. F., 2001, *Lay people's evaluation of historic sites*. Landscape and Urban Planning 59, p. 111-123. The Netherlands, Science Direct 2002.
- Cookson, V., 2003, *A user's guide*. English Heritage, London.
- Demirgüç-Kunt, A & Levin, R., 2002, *Bank-Based and Market-Based Financial Systems; Cross-Country Comparison*. Development Research Group, The World Bank, Finance Department, Beck, T. University of Minnesota.
- Elmgren, B, Degerman, A, Håkansson, H., 1955, *Kulturfondsutredningen 15/6. Betänkande och förslag angående riktlinjer och former för fördelning av lotterimedel avgivet av 1948 års utredning om en statens kulturfond*. Kgl. Handelsdepartementet Stockholm.
- English Heritage, 2003, *The Work of English Heritage. Looking after Historic buildings*, London
- English Heritage, 2004, *A Guidance Note on Historic Environment Champions*, London
- Exner, J., 1991, *Restaurering- Tabl/Vinding. Bygningsreaturering helhed, hensyn & samarbehde*. RAADVAD, Köpenhamn.

- FKN, Föreningen Kultur och Näringsliv, 2001, *Jämförande studie om avdragsrätt för kultursponsring i Sverige, Danmark, Storbritannien, Tyskland och Frankrike*. Öhrlings PricewaterhouseCoopers, Stockholm.
- FSA, Financial Service Authority, 090301, *The Turner Review. A regulatory response to the global banking crisis*. Financial Service Authority, London.
- Hayen, R. L., 1983, *How to design a financial planning model*. University of Nebraska. Long Range Planning Vol.16. No.5.pp 111-122.
- HELM, 2004, (Historical Environment Local Management), *Your guide to the historic environment*. English Heritage, London.
- HLF (Heritage Lottery Fund), 2004, *Winning the Lottery: Ten years of Funding for Heritage*. Heritage Counts 2004, The State of the Historic Environment, London.
- Herrero, L.C. & Sanz, J.A, 2002, Economic valuation of the cultural heritage: application to four case studies in Spain. *Journal of Cultural Heritage* 5:1/2004.pp101-111. Science Direct 2004.
- Ipekoglu, B., 2004, An architectural evaluation method for conservation of traditional dwellings. *Building and Environment* 41, p. 386-394, Turkey. Science Direct 2005.
- Katsarova, I.,2008, *Economic and Social Cohesion*. Fact Sheets on the European Union, 07/2008.
- Kirschbaum, J.,1994, *Protection of the architectural heritage- policies and strategies of the Council of Europe*. Report from Seminar, June 1994, Svenska Unesco-rådets skriftserie 4/1994., Stockholm.
- Kluger, M., 1984, *Renovating? Take a look at the new short-term paths to financing*. Finance Department, New York. *Trustee* 37:2/1984pp. 17-20.
- Levin, R., 2000, *Bank-Based or Market-Based Financial Systems: Which is Better?* Carlson School of Management, University of Minnesota.
- Moore, D., 2003, *The Fiscal Framework for Corporate Philanthropy in CEE and NIS*. The International Journal of Not-for-Profit Law, Vol 6. 2/2004, Budapest.
- NLC, 2003, *New York Landmarks Conservancy 30th Anniversary Report 2003*. New York Landmarks Conservancy, New York.
- Nilsson, A., 2007, *Vart är KD på väg?*, Trelleborgs Allehanda 070901.
- Pickard, R. & Pickerill, T., 2002, *Conservation finance 1: support for historic buildings*. *Structural Survey* 20:2, pp.73-77.
- Pickard, R. & Pickerill, T., 2002, *Conservation finance 2: area-based initiatives and the role of foundations, funds and non-profit agencies*. *Structural Survey* 20:4, pp 112-116.
- Povoledo, E., 2007, *Vatican Takes Steps to Control Overcrowding*. The New York Times, 070218.
- RAÄ (2005) *Kartläggning och redovisning av fördelningen av anslaget 28:26 ap 1. Bidrag till kulturmiljövård för åren 2000-2004*. Riksantikvarieämbetet, Stockholm.
- RAÄ, 2006, PM. *Långskiktigt hållbar förvaltning och differentierad användning av kyrkor*. Dokumentation från RAÄ:s seminarierierie våren 2006. Stockholm.
- Riksantikvarien (2006) 06-04055-9 Tilskuddsmilder Kriterier nr 4 doc 246195.
- Ruijgrok, E.C.M., 2005, *The three economic values of cultural heritage: a case study in the Netherlands*. *Journal of Cultural Heritage* 7 March 2006.pp.206-213. Science Direct 2006.
- Schuster, J. M., 1998, *Neither Public Nor Privat: The Hybridization of Museums*. *Journal of Cultural Economics* 22: 127-150.
- SFV Report, 2005, *Underhållssituationen i bidragsfastigheterna. Statens fastighetsverk (SFV) vill med följande rapport informera regeringen om den brist på överensstämmelse som SFV upplever finns mellan tillgången på resurser och uppdragets omfattning förande bidragsfastigheterna*. SFV, Stockholm.
- Sjö, B, 2003, *Bantade anslag till Kulturmiljövård i Skåne*. Sydsvenska Dagbladet.
- Skarin. Pålsson, I., 1996, *Byggnadsliggare Blekingegården*. Riksantikvarieämbetet, Lund University, Lund.
- Skarin Pålsson, I., 1996, *Byggnadsliggare Abriksgården*. Riksantikvarieämbetet, Lund University, Lund.

- Skarin Pålsson, I., 1999, *Models for an objective evaluation of Restorations*. Lund University, Lund.
- Skarin Pålsson, I., 2004, *A Comparative Study of the financial support/sponsoring in twelve restoration projects from Denmark, Germany, Great Britain, Norway, Finland and Sweden*. Lund University, Lund.
- Skarin Pålsson, I., 2004, *Kulturvård finansieras privat i forna DDR*. Byggnadskultur 4/04, Stockholm.
- Skarin Pålsson, I., 2005, *A Comparative study of the financial support in twelve restoration projects from Denmark, Germany, Great Britain, Norway, Finland and Sweden*. Paper; International Expert Seminar on the Economics of Heritage Preservation Helsinki.
- Skarin Pålsson, I., 2008, *New Finance Models for the Built Cultural Heritage*. Paper; European Conference on Research for Protection, Conservation and Enhancement of Cultural Heritage, Ljubljana.
- Skogskär, M., 2008, *Avdnag som kan bidra*. Sydsvenska Dagbladet, 080808, Malmö.
- SOU (Statens offentliga utredningar) 1965:10 (1965) *Antivitetetskollegiets centralorgan för svensk kulturminnesvård*. Ecklesiastikdepartementet, Stockholm.
- SOU (Statens offentliga utredningar) 1956:26 (1980) *Förarbete till lagen (1960:690) om byggnadsminnen Del I*. RAA Stockholm.
- Stone, W., 2001, *Measuring social capital. Towards a theoretically informed measurement framework for researching social capital in family and community life*, No24 February Australia.
- Ström. Melvinger, K., 2008, *Dan Olofssons arbete mot aids belönas*. Sydsvenska Dagbladet, 080609, Malmö.
- Svedberg, O., 1982, *1800-talet arkitekternas århundrade. En europeisk översikt*. Lund University, Lund.
- Söderberg, S., 2004, *Vem vill bli kulturminister?*, Sydsvenska Dagbladet, 041017.
- Temo, 1999, *Kultursponsring i Sverige*. Föreningen Kultur och Näringsliv, Stockholm.
- Throsby, D., 1999, *Cultural Capital*. Department of Economics, Macquarie University, Sydney. Journal of Cultural Economics 23:3-12, 1999.
- TNT, 2004, *The National Trust. An Overseas Perspective on the National Trust of England Wales and Northern Ireland*. National Trust, London.
- Trupiano, G., 2004, *Financing the culture in Italy*. Università Roma Tre. Journal of Cultural Heritage 6:4/2005.pp 227-343, Science Direct 2005.
- Uphoff, N., 2001, *Understanding social capital: learning from the analysis and experience of participation*. Cornell University, Washington DC.
- UNESCO, 2006, *Convention concerning the Protection of the World Cultural and Natural Heritage, 13th Session*. Unesco, Vilnius. Lithuania.
- Weese, H. M., 1976. Journal of Architectural Education, vol. 29, 4/1976, New York. Marston Fitch (1998, p. 32f)
- WMF, 2007, *World Monuments Fund 2007 Annual report*. World Monuments Fund, New York.
- WMW, 2008, *World Monument Watch 2008 list of 100 most endangered sites*. New York.

Archive materials

- Curman, C. 1924 July, Letter from Curman to the Maglarp parish. Archive at County Administration Office, Malmö.
- Hegelund & Marsvik Arkitekter AB, 1992-09-19, *Utredning av kostnader för att återställa och bevara Maglarps Nya Kyrka*. Lund. Archive at County Administration Office, Malmö.
- Hegelund & Marsvik Arkitekter AB, 1999-11-15, *Maglarps Nya Kyrka. Utredning av kostnader för en utvändigt renovering*. Lund. Archive at County Administration Office, Malmö.

- Trelleborgs Allehanda, 1909-07-19, *Nya kyrkan i Maglarps*. Archive at County Administration Office, Malmö.
- Regeringsrättens Dom (Supreme Court Verdict), 2005-06-10, *Tillstånd till rivning av kyrkobyggnad*. Stockholm. Archive at County Administration Office, Malmö.
- Riksantikvarieämbetet, 2007-03-19, *Yttrande. Angående dokumentation vid rivning av Maglarps nya kyrka*, Trelleborgs kommun. Stockholm. Archive at County Administration Office, Malmö.
- Sjögren, B., 1996-10-11, Letter from the Maglarps parish to the regional curator Carin Bunte. Archive at County Administration Office, Malmö.
- Yttrande, RAÄ (2007) "Angående dokumentation vid rivning av Maglarps Nya Kyrka, Trelleborgs kommun. Stockholm.
- Visby Ringmur, Gerdt Lundeberg, Cementa, 91-12-17, ATA Riksantikvarieämbetet.
- Bidrag till kampanjen "Rädda Visby Ringmur!", Lars Cnattingius, 91-08-29, ATA Riksantikvarieämbetet.
- Sponsoravtal, 90-11-14, 1154/91, ATA Riksantikvarieämbetet.

Oral sources; interviews

- Agnesson, Peter/Jönsson, Jonas, employees at the Trellegräv (demolishing firm), 09-01-01 (telephone).
- Andersen, Christian , architect and project manager at Realdania Copenhagen, 08-04-02 (mail, telephone, meeting).
- Baranski, Marek. Architect and archaeologist. Former managing director at the International Information Department, Warsaw Workshop PPKZ, 1998-03 (meeting).
- Bedhertz, Michael, office manager cultural buildings Landesamt für Kultur und Denkmalpflege Mecklenburg Vorpommern, Stralsund .08-05-20, (Telephone)
- Bergdahl, Anneli, administrator at the Röda korset, Stockholm, 08-05-13 (mail, telephone).
- Bodet, Elmar, building site manager St. Jacobi Church, Büro Tischlerei und Altbauerhaltung, Stralsund, 1998-1999 (meetings).
- Boxer, Anna, curator at English Heritage, Manchester Office, 08-05-29 (mail, telephone)
- Bolgar Susan, administrator at Föreningen kultur och näringsliv, Sweden, 08-04-01, (telephone, mail).
- Breen, Peg, president at the New York Landmarks Conservancy, New York, 08-04-08, (meeting, telephone)
- Brenam, M., architect at the Murphy Architects, Edinburgh, 09-08-10 (mail, telephone)
- Bylander Lotta, administrator at the Svenska föreningen för byggnadsvård, Stockholm, 08-05-26 (mail, telephone).
- Böhnke, Bent. architect specialized in building conservation, Bent Böhnke Architekt, 09-09-04 and 1997-99 (meeting, mail, telephone).
- Classon, Per, administrator at the Swedish Ministry of Finance. Finansdepartementet, 08-03-13 (telephone).
- Cnattingius, Lars, curator at the National Board of Antiquities. Riksantikvarieämbetet (former employee), 08-03-20 (mail, telephone).
- Dickson, Kate., project manager at the Ancoats Building Preservation Trust (ABPT), 09-07-15 (mail, telephone).
- Enger, Anne Gro, administrator at the Department of Finance, Finansdepartementet, Skatteavdelningen. Oslo, 08-06-13 (mail, telephone).
- Erlandsen, Morten, administrator at the Statsbygg (National Property Board), Oslo, 08-06-16 (mail, telephone).

Freiheit, frau, the local warden of Rossewitz Palace Freiheit, 09-07-25 (letters, telephone).

Filipavichėne, Giėdre, architect at the Paminklu Restauravimo Institutas (The Institut of Monument Protektion) Vilnius, Lithuania, 1997-2000 (meetings). See Skarin Pålsson (2001, p. 66ff).

Flach Wilkie, Martha administrator at the World Monuments Fund, New York. USA, 08-05-16 (mail, telephone).

Forseke, Karin, non-executive board member of the British Financial Service Authority (FSA), 09-04-10 (meeting).

Garett, Cynthia, Superintendent Statue of Liberty and Ellis Island, National Park Service, New York, 08-04-08 (meeting).

Gerber, Heidi, administrator at the Deutsche Stiftung Denkmalschutz, Potsdam. Germany, 08-05-20 (mail, telefon).

Gobblert, Helga, adminstrator at Brandenburger Schlösser, 09-08-10 (telefone, mail).

Gro-Enger, Anne, administrator at the Department of Taxation, Finansdepartementet, Oslo, 08-05-15 (mail, telephone).

Grudin, Ola, administrator at the Rėda korset, Stockholm, 08-05-13 (mail, telephone).

Gyllenhammar, Ulf, curator at the Swedish National Heritage Board, Riksantikvarieämbetet (RAĀ), Stockholm 08-03-31 (mail, telephone).

Herrera, Alexander, director Technical Service Centre at the New York Landmarks Conservancy, New York, 08-04-08 (mail, meeting).

Holden, Julian, curator at the at English Heritage, Manchester Office, 08-05 (meeting).

Holmberg, Ulf, administrator at the World Wide Fund for Nature, 08-05-12 (mail, telephone).

Johansson, Bengt. OH., former regional curator of Kalmar in Sweden, 08-05-26 (telephone).

Jönsson, Siv, financial administrator at the Swedish National Heritage Board, RAĀ, Stockholm, 09-06-25, (mail, telephone).

Karlsson, Birgit, administrator at The Department of Taxation, Skattemyndigheten, Jönköping, 08-05-20 (mail, telephone).

Klemisch, Jürgen, architect administrator at Brandenburger Schlösser, 04-10-10 (meeting, telephone).

Kolmanen , Mariokka, administrator at the Stiftelsen för kulturarvet i Finland, 08-05-05 (telephone, mail).

Klimaviciene, Ruta, architect at the Paminklu Restauravimo Institutas (The Institut of Monument Protektion) Vilnius, Lithuania, 1997-2000 (meeting).

Krigström, Inger, priest in Hammarlöv (Maglarp) parish since 2004, 09-09-03, (telephone, mail).

Kirmitz, U. architect specialized in building conservation, Architektbüro Rassumssen u. Partner, 09-07-05, (mail, telephone)

Lampe, Francien, curator and administrator at the Riksantikvaren, The Directorate for the Cultural Heritage, Oslo, 08-04-08 (mail, telephone).

Ljungdahl, T, administrator at the Department of Taxation, Skattemyndigheten, Stockholm, 09-12-15 (telephone).

Madsen-Andersen, Marianne, administrator at the Department of Taxation, Skattecentret, Copenhagen, 08-05-21 (mail, telephone).

Mattinen, Maire, curator at the Museiverket, National Board of Antiquities, Finland, 08-04-02 (mail, telephone).

Moth, Ken, architect specialized in building conservation, Building Design Partnership (BDP), Manchester, 09-08-10 (mail, telephone).

Morgen, Mogens, office manager cultural buildings, Kulturarvsstyrelsen, Copenhagen, 08-05-23 (telephone)

Munger, Helen, project manager at the Heritage Lottery Fund. London, 04-11-19 (meeting).

Maegaard Nilesen, Mette, architect; Tegnestuen Kvisten in Copenhagen, 1997-98 (meeting).

Mårtensson, Nils-Olof, board member of the Uppåkra archeological Foundation, Stiftelsen Uppåkra Arkeologiska Center, 11-05-10 (mail, telephone).

Northey, Sara, senior policy & campaigns officer, communities and development, National Trust. London, 04-11-19 (meeting).

Nyström Göran, Administrator at the *Tychor Brabe minnena*, Cultural Department Landskrona municipality, 09-08-31 (telephone).

Olsen, Torben, office manager cultural buildings, Kulturarvsstyrelsen (today retired), Copenhagen, 04-05-20 (meeting).

Pedersen, Marko, administrator at the Nordic World Heritage Foundation, Oslo. Norway, 08-05-16 (telephone).

Pfütznar, C. preast in the Lippe Parish, Licentiat study, 1999 (telephone).

Romberg, T., regional curator of Skåne Region, 2008 (meetings).

Rönndal-Tenghammar, office manager at the Regin, Palaces and Properties Agency. Slots- og Ejendomsstyrelsen, Copenhagen, 08-03-14 (mail, telephone).

Sampanin-Ahlgren, Satu, administrator at the Senatfastigheter (National Property Board), Helsinki, 08-06-15 (mail, telephone).

Schwanborg, Ingrid, curator at the Culture environment department, The Swedish National Heritage Board (RAÄ), 09-07-10 (telephone).

Selling, Inger, administrator at the Swedish National Heritage Board, Riksantikvarieämbetet, 08-03-14 (telephone).

Seppälä, Kirsti, administrator at the Finansministeriet, Helsingfors. Department of Finance Finland, 08-05-14 (mail, telephone).

Silén Håkan. Head of department, Landskrona Parish Council, 090820 (telephone).

Simonsson, Lena, office manager at the National Property Board, Statens Fastighetsverk (SFV), Stockholm, 08-03-14 (mail, telephone, meeting).

Sjöberg, Erika, financial department at the National Property Board, Statens Fastighetsverk (SFV), Stockholm, 08-03-18 (mail, telephone).

Skogsberg, Jonas, administrator and EU funding adviser at Swedish National Heritage Board (RAÄ) 11-06-15 (telephone).

Skoglund, Mathias, administrator at Bingolotto, 08-06-17, (mail, telephone)..

Sjögren, Birgitta, chairman of the Church Council of Hammarlöv parish during the Maglarp process, 09-09-01 (telephone).

Stenfält, Jan, administrator at the Kultur Skåne, 08-04-01 (telephone).

Söderqvist, Johan, administrator at Svenska Spel, 11-05-06 (mail, telephone)

Tinnerdal, Jenny, administrator at the Ministry of Finance. Finansdepartementet, Oslo, 08-03-14 (mail, telephone).

Thomas, Ursula, curator at Deutsche Stiftung Denkmalschutz in Bonn, Germany, 99-08-13 (letters).

Thorén, Mikael, administrator at the Department of Finance, Stockholm, 10-05-06 (mail, telephone).

Turesson, Rolf, manager at the Skåne County Council, Region Skåne, 08-03-19 (mail, telephone) .

Turtinen, J. Swedish representative for Nordic World Heritage Fund, Swedish National Heritage Board (RAÄ), 08-05-15 (mail, telephone).

Törnqvist-Plewa, Barbara professor at the Öst- och Centraleuropa studier (fr.Slaviska Institutionen), Lunds University. Sweden, lectures during 1997.

Valanchon, Natalie, administrator, World Heritage Fund, UNESCO. World Heritage Centre. Communication, Education & Partnerships Section, Paris, 08-06-14 (mail, telephone).

Weber, Mark, technical director at World Monuments Fund, New York, 08-05-10, (mail, telephone).

Wienands, Klaus, curator at the Landesamt für Denkmalpflege, Stralsund, 1997-1998 (meeting).

Wickman, Pia administrator of finance at the Greenpeace Stockholm, 08-05-13 (mail, telephone).

Wolender, Thomasz, curator at the PSOZ Wojewodski Oddział Szczecinski (State Service for Protection of Monuments Szczecin) Poland, 1997-2000, 2008 (letters, meeting).

Zülch, A.K., architect specialized in building conservation. B&Z Architekten H.v.Bassewitz & A.K. Zülch, Hamburg, 09-07-10 (mail, telephone).

Web-based sources

(The websites have been used according to the dates below and their contents are liable to changes)

Aga Kahn Trust for Culture, 080420, at <http://www.akdn.org/about.html>
Architectural Heritage Fond, 080423, at <http://www.ahfund.org.uk/>
Arts & Business, 080429, at <http://www.aandb.org.uk/render.aspx?siteID=1&navIDs=1,191>
Bingolotto, 080609, at <http://www.folkspel.se/Templates/Article>
Brandeburger Schlösser, 080426, http://www.schloesser-gmbh.de/eng/index_eng.html
Boito, Camillo, 081001, at http://en.wikipedia.org/wiki/Camillo_Boito
Burra Charter 1984, 081028, at <http://www.marquis-kyle.com.au/bcsignificance.htm#2.0>
Congress of Athens 1931, 080929, at www.ICOMOS.org
Constructivism, 091101, at http://en.wikipedia.org/wiki/Social_constructionism
Council of Europe, 080421, at http://www.coe.int/T/DG4/CultureHeritage/Default_en.asp
(Framework Convention on the Value of Cultural Heritage for Society)
Council of Europe, 101215, at <http://www.coe.int/t/dg4/cultureheritage/EHD>
'Culture economics', 090818, at http://en.wikipedia.org/wiki/Cultural_economics
Cultural significance 1999, 081028, at www.nsw.nationaltrust.org.au/burracharter.html#use
Declaration of Amsterdam 1975, 081017, at <http://www.icomos.org/docs/amsterdam.html>
Declaration of Dresden 1982, 081105, at <http://www.icomos.org/docs/dresden.html>
Declaration of Foz 2008, 081127, at www.international.icomos.org/centre_documentation/declaration-iguacu-eng.pdf
Declaration of Tlaxcala 1982, 081018, at <http://www.icomos.org/docs/tlaxcala.html>
Declaration of Rome 1983, 081110, at <http://www.icomos.org/docs/rome.html>
Declaration of San Antonio 1996, 081115, at http://www.icomos.org/docs/san_antonio.html
Denmark, 090310, at <http://en.wikipedia.org/wiki/Denmark>
Deutsche Stiftung Denkmalschutz, 080428, at <http://www.denkmalschutz.de/home.html?&L=2>
Dramaten, 090810, at <http://www.wikipedia.org/wiki/Dramaten>
English Heritage, 080422, at <http://www.english-heritage.org.uk>
Egypt, 080426, at <http://touregypt.net/abusimbel.htm>
European Charter of the Architectural Heritage 1975, 081017, at http://www.icomos.org/docs/euroch_e.html
Faro 2005, 081128, at <http://conventions.coe.int/Treaty/EN/Treaties/Html/199.htm>
Finance Models, 090720, PlanWare, Invest-Tech Limited at <http://www.planware.org/financialprojections.htm#1>
Finland, 090310, at <http://finland.fi/netcomm/news/showarticle.asp?intNWSAID=25911#1700>
Flemish Funds-in-Trust, 080420, at <http://whc.unesco.org/en/ffit>
Folkspel, 090510, at <http://www.folkspel.se/>
Fondation du Patrimoine, France, 080519, at <http://www.fondation-patrimoine.com/en/>
Fondation du Patrimoine, 080617, at <http://www.fondation-patrimoine.com/en/fondation-moyens.php4>
Fördervereine, 090224, at <http://de.wikipedia.org/wiki/F%C3%B6rderverein>
Föreningen Kultur och Näringsliv, 080410, at <http://www.kultur-naringsliv.se/pages/387.asp>
Germany, 090312, at http://en.wikipedia.org/wiki/Politics_of_Germany

Glücksspirale, 080818, at http://www.ciao.de/GlucksSpirale__Test_2534075
 Great Britain, 090312, at http://en.wikipedia.org/wiki/Kingdom_of_Great_Britain
 Greenpeace (080608)<http://www.greenpeace.org/international/about/history>
 Grounded Theory, 091001, at <http://infovoice.se/fou/bok/kvalmet/10000011.htm>
 Hallandsmodellern, 090926, at <http://hallandsmodellern.org/>
 Helm (Historical Environment Local Management), 080424, at <http://www.helm.org.uk/server/show/nav.7751>
 Heritage Counts” (080613) www.english-heritage.org.uk/hc/server/show/nav.10718
 Historic Charleston Foundation, 090227, at <http://www.historiccharleston.org/about/who.html>
 ICOMOS New Zealand 1992, 081109, at http://www.icomos.org/docs/nz_92charter.html
 Inkpen, R., 2004, Atmospheric Pollution, Climate Change and Historic Buildings. Building Conservation Directory. <http://www.buildingconservation.com/articles/atmospheric/atmospheric.htm>
 International cultural tourism charter Mexico 1999, 081120, at www.international.icomos.org/charters/tourism_e.htm
 International Symposium Budapest, 081005, at www.icomos.org/docs/contemporary_architecture.html
 Interpretive and phenomenology (091101) [http://en.wikipedia.org/wiki/Phenomenology_\(philosophy\)](http://en.wikipedia.org/wiki/Phenomenology_(philosophy))
 ‘Journal of Cultural Economics’ ,090818, at <http://www.culturaleconomics.org/history.html>
 J. Paul Getty Trust, 080413, at http://www.getty.edu/grants/new_priorities/message_director_2008.html
 Kraksubutik, 080504, at <http://kraksubutik.krak.dk/templates/pricelist.asp?groupguid=10996>
 Kulturminnesfondet, 080328, at <http://www.kulturminnefondet.no/>
 Kulturstiftung des Bundes, 080428, at <http://www.kulturstiftung-des-bundes.de/main.jsp?categoryID=202835&languageID=1>
 Kölner Dom, 090712, at <http://www.koelner-dom.de/geschichte.html>
 Landmark Trust, 080420, at [http://www.landmarktrust.org.uk/about/Lottery history, 090220, at http://www.historyoflottery.com/beginnings.html](http://www.landmarktrust.org.uk/about/Lottery%20history)
 Ljubljana Process, 081101, at http://www.coe.int/t/dg4/cultureheritage/regional/SEE/Default_en.asp
 Messerschmitt Stiftung, 080412, at <http://www.schloss-anras.com/messerschmittstiftung.html>
 Meseberg, Messerschmitt, 090221, at http://de.wikipedia.org/wiki/Messerschmitt_Stiftung
 Miljöministeriet, Byggnadsarvstrategin, 080502, at <http://www.ymparisto.fi/default.asp?contentid=107298&lan=SV>
 Morris, W., 1877, Manifesto of the Society for the Protection of Ancient Building (SPAB), 081110 at <http://www.marxists.org/archive/morris/1877/spabman.htm>
 Murray’s Mill, 091210, at http://www.ancoatsbpt.co.uk/projects_mills.htm
 Myntkabinettet, 080502, at <http://www.myntkabinettet.se/r%C3%A4knare.htm>
 Nara Document 1994, 081102, at http://www.international.icomos.org/naradoc_eng.htm#va
 Nara Convention 1994, 091112, at http://www.international.icomos.org/naradoc_eng.htm#va
 National Park Service, 09 12 20, <http://www.nps.gov/nhl/>
 National Trust, 080421, at www.nationaltrust.org.uk
 NGO, 080610 at <http://www.un.org/dpi/ngosection/brochure.htm>
 Norskt Kulturarv, 080429, at <http://www.kulturarv.no/index.aspx?article=24853&mid=24853>
 Norway, 090310, at http://en.wikipedia.org/wiki/Constitution_of_Norway
 Norwegian Culture Fond, Norsk Kulturminnefond, 080505, at <http://www.kulturminnefondet.no/>

PACT, 080502, at <http://whc.unesco.org/en/Partnershipprinciples/>
 Postkodslotteriet, 080609, at <http://www.postkodlotteriet.se/OmOss.htm>
 Popa, S., *Macroeconomic models of economic growth based on investments*. Universitatea din Pitesti. 090510, at Web
 Quebec Declaration on the spirit of place 2008, 081202, at www.international.icomos.org/home.htm
 Realdania, 080428, at <http://www.realdania.dk/In+English/Content/Intro.aspx>
 Realdania, 080428, at <http://www.realdania.dk/In+English/Content/Grantmaking+strategy.aspx>
 Red Cross and Red Crescent Movement, 080608 at http://www.ifrc.org/who/history.asp?navid=03_09
 Resolutions of the International Symposium Rothenburg 1975, 081020, at www.icomos.org/docs/small_towns.html
 Samuel H. Kress Foundation, 080423, at <http://www.kressfoundation.org/about/legacy.aspx?id=82>
 Serageldin, I. & Grootaert, C., Defining social capital: an integrating view. World Bank at http://www.exclusion.net/images/pdf/778_okili_serageldin_grootaert.pdf
 Significance, 081012, at http://www.international.icomos.org/charters/tourism_e.htm
 Sjölin, E., 2007, *Vilket värde har mikrokrediter som kognitivt och strukturellt socialt kapital? : En fallstudie av Grameen Bank*, Södertörns Högskola, 081126, at <http://sh.diva-portal.org/smash/record.jsf?pid=diva2:15400>
 Skatteverket, 091202 at <http://www.skatteverket.se/privat/skatter/fastigheterbostad/husarbeterot/>
 State Parties, ICOMOS, 090812, at <http://whc.unesco.org/en/statesparties/>
 Stiftelsen för kulturarvet i Finland, 080418, <http://www.kulttuuriperinne.com/tiedostot/stiftelsen2008.print.pdf>
 Stockholm declaration 1998, 081115, at http://www.international.icomos.org/charters/stocdec_e.htm
 Svenska byggnadsvårdsföreningen, 080430, at <http://www.byggnadsvard.se/?id=start&-session=nestor:D5EED9720eeb2319C2iLR2DC5D49>
 Sweden, 090310, at http://en.wikipedia.org/wiki/Sweden#Public_policy
 Tax exemption France, 080523, at <http://www.fondation-patrimoine.com/en/soutenez-nos-actions.php4>:
 Tax-exemption Germany, 080613, at <http://www.denkmalschutz.de/steuer.html>
 Tax exemption Great Britain, 080612, <http://www.landmarktrust.org.uk/about/TCM/>, 08 0324, www.encora.eu/coastalwiki/Travel_cost_method
 Top-down and bottom-up design, 090215, at <http://en.wikipedia.org/wiki/Top-down>
 The Flemish Fund in Trust, 080502, at <http://whc.unesco.org/pg.cfm?cid=225>
 The Getty, 080429, at <http://www.getty.edu/conservation/institute/>
 The Heritage Agency of Denmark, 080612, at <http://www.kulturarv.dk/english/index.jsp>
 The Heritage Canada Foundation, 080429, at <http://www.heritagecanada.org/eng/mission.html>
 The New York Landmarks Conservancy, 080410, at <http://www.nylandmarks.org/>
 The World Bank. Social capital Measurement in CDD Operations, 081208, at <http://www.worldbank.org/WBSITE/EXTERNAL/TOPICS/EXTSOCIALDEVELOPMENT/>
 UNI Stiftelsen, 0804 27, at http://www.stiftelsen-uni.no/index.php?art_id=55
 Stiftelsen Uni, 080403, at <http://www.stiftelsen-uni.no/>
 Uppåkra, 080325, at <http://sv.wikipedia.org/wiki/Upp%C3%A5kra>
 Uppåkra, Stiftelsen Uppåkra Arkeologiska Center, 110402, at <http://www.uppakra.se/>
 Venice Charter 1964, 081003, at www.international.icomos.org/charters/venice_e.htm
 Vieira, N. M, 081001, *A discipline in the making classic texts on restoration revisited*, at <http://www.ceci-br.org/novo/revista/viewarticle.php?id=13&layout=html>
 von Goethe, J. W., 1771, 080422, *Von Deutscher Baukunst*. Jürgen Kühnle, 1999. at <http://www.wissen-im-netz.info/literatur/goethe/aufsatz/02.htm>
 Victoria Falls 2003, 081110, at http://www.international.icomos.org/charters/structures_e.htm

Vitruvius 1, 080922, at <http://sv.wikipedia.org/wiki/Vitruvius>
Vitruvius 2, 080922, at <http://www.cambridge.org/catalogue/catalogue.asp?isbn=9780521690539&cs=exc>
Winckelmann, 080303, at www.kirjasto.sci.fi/winck.htm
World Heritage fund, 080417, at <http://whc.unesco.org/en/169/> and <http://whc.unesco.org/en/funding/>
World Heritage List (090812) <http://whc.unesco.org/en/list>
World Monument Fund, 080415, at <http://www.wmf.org/history.html>
World Monument Watch, 090812, at <http://www.wmf.org/watch.html>
World Wide Fund for Nature (080504) <http://www.wwf.se/om-wwf/historik/1122850-ww-fs-historia>
Xi'an declaration 2005, 081122, at <http://www.international.icomos.org/xian2005/xian-declaration.htm>

Illustrations

For all illustrations and photos, which are not produced and copyright by the author, their sources are noted separately in the chapters or listed below.

141.1 Schloss Putbus from the 1920's, <http://www.google.se>
3231.1 Evangeliku Liuteronu kirché, Paminklu Restauravimo Institutas.
742.1 Rossewiz palace in the early 1990's, Bent Böhnke.

*Conference Documentation and Conservation of
Wooden Towns*
NorFa, Tallinn September 1999.

Models for an objective evaluation of Restorations

Postgraduate course in Tallinn 20-25 of September 1999

by doc.stud Ingela Pålsson. Skarin ark . maa Lund University Sweden

A Model to improve recollection of knowledge for the future

In this paper I will describe my method to make an objective analyse of filed studied building restorations by using a fixed model. This work is a part of my doctor's thesis titled "Restoration of the Built Heritage around the Baltic Sea at the end of the Millennium -The case of Lithuania, Poland, Germany, Denmark and Sweden from past to present". In this thesis my intention is to develop means, an instrument, to improve recollection of experiences made at previous Building Restorations. The countries in the study have a related building culture thanks to the trade of goods and services across the the Baltic Sea ever since the early middle-ages. Fundamental for the study is whether or not the development within restoration of the built culture created a historical pattern that we can decipher and learn from in order to connect to present restorations. The final question is if this pattern could be transformed into guidelines which could give directions for future investments in education, legislation and financing. This would benefit restoration in general as well as future cooperation within the field between the countries around the Baltic Sea

Background

The studies began in 1997 and comprise 15 restorations in progress which represent the different building categories from each country; the castle, the church and vernacular building. Previous comparative studies of restoration methods between countries already do exists (Fitch "Historic Preservation" 1982 and Denslagen "Architectural restoration in Western Europe" 1994) but in contrast to this earlier works my study is an attempt to obtain a clear picture of the restorations at present based on interviews and observations. The main question through my analyse has been:

Why does the final result, the restored building, not always correspond to the first aim for the restoration? In order to give an answer to this we must find the solution to following questions:

- *For what reasons do we save buildings out of the the built heritage?*
- *What does it mean to protect our Built Héritage in practice?*
- *What parts of the restoration process have the most influence on the result?*

For what Reasons do we save Buildings out of the Built Heritage?

Some buildings are protected when they are indispensable for us and other because of poverty or neglect. Distinctions can be made between what I call a *conscious protection*, an intentional act and an *accidental protection*, when the act is unintentional. When a building represent a value or symbol for us the protection is intentional and when neglected the protection is unintentional

- Value: Historical-, originality-, utility- and monetary value (face value).
- Symbol: For a nation, a people or a religion.

The conscious protection is explained with the example of Castle Penzino in Star-gard, Polen in this diagram.

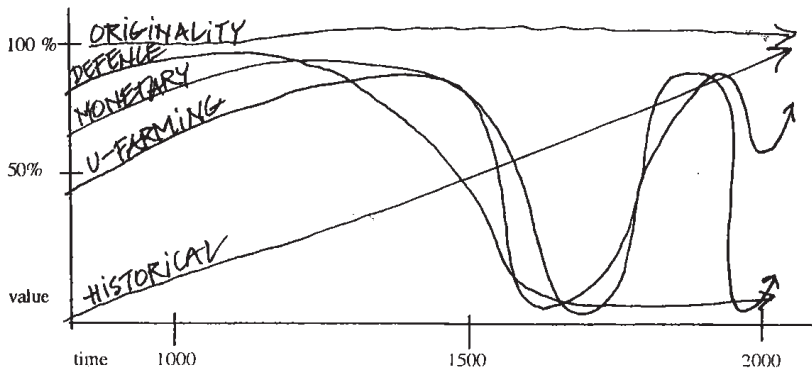

Accidental protection;

- Sustainable material
- Lack of capital for replacement
- To high expenses for demolition



The value is unique for each historical period therefore difficult to define for the future. The evaluator is left to choose the most important historical period himself for a valuation of the building. A built object can have different symbolic meanings depending on the number of people that it have been appreciated by. All accidental protection are unforeseeable.

What does it mean to protect our Built Heritage in practice?

Restoration is a building process in a teamwork. In order to distinguish restorations from building production in general following comparison have been made:

New Production:

- Fixed time schedule which facilitates financial and personnel means
- One aim with the work; from a non-existing to a complete building
- Obvious roles in the teamwork
- Few actors involved on the idea of the final project
- Less demands of an efficient teamwork.
- General demands of skills.

Restoration:

- Less fixed time schedule due to unforeseen problems on the object which gives insufficient financial and personal means
- Many aims with the work such as protection, reconstruction, conservation or education
- Indistinct roles in the teamwork depending on former experiences
- Many actors involved on the idea of the final project on an existing building
- High demands of an efficient teamwork
- High demands of skills.

Restoration is a more complicated process than new production with higher demands on the teamwork than building production in general. A simplification of the whole restoration process gives following model with these distinct groups: *Value* (Valuation), *Finance* (Financing), *Law* (Legislation), the *Teamwork* and *Documentation* (Logbook). The last group *documentation* like a Logbook for future restorations do not always take an evident position in the process. A similar model for new production would lack the *Value* as well as the *Documentation* parts.

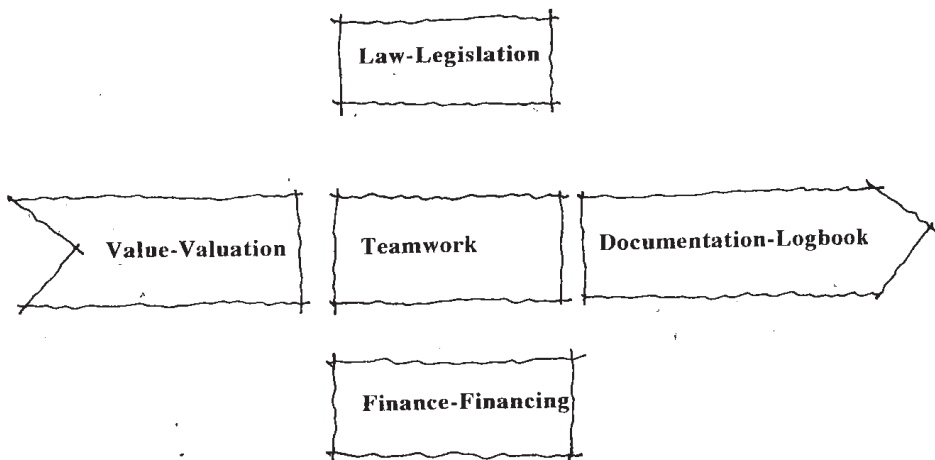

What Parts of the Restoration Process have the most Influence on the Result?

The information and directions given from the Value, Finance and Law parts are interpreted by the actors involved in the teamwork which makes this position most influential in the process. But facts about the teamwork presented with these questions are of vital importance for the restoration.

- What kind of actors are involved in the team and what are the ranking orders?
- What roles do the actors have in the team?
- What influence do the actors have on the teamwork, finance and legislation?
- What are the backgrounds of the the actors like (education, practical experience)?
- What relation is there between the building object and the actor (personal aim)?
- At what in building stage are the actors active?

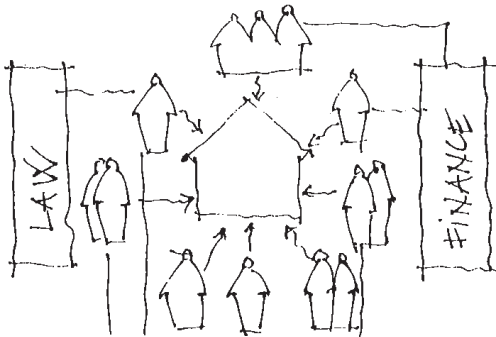

Following different building stages characterise restoration works:

1. Preliminary work (definition of aim, means of financing and legislative demands)
2. Historical investigation I; measurement, practical investigation on site.
3. Historical investigation II; theoretical investigation, compile research- guidelines.
4. Projecting and production of drawings.
5. Practical works on the building site.
6. Documentation.

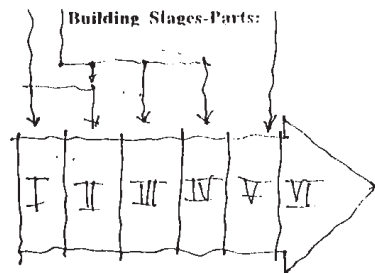

These final facts about the actor and his involvement in the process belongs undoubtedly to the most important information in order to understand and objectively evaluate the Restoration and its final product -the restored building.

Paper 2

*International expert seminar on the economics of
heritage preservation*

Helsinki, Finland December 12-13, 2005.

International expert seminar on the economics of heritage preservation Helsinki, Finland December 12-13, 2005

Ingela Pålsson. Skarin arch. MAA tech. lic
Inger Strömberg fil. Kand

Division of Architectural Conservation & Restoration
Department of Construction and Architecture
Lund Institute of Technology, Sweden

New Finance models for the Built Cultural Heritage

Introduction

Ever since the 1890ies the built cultural heritage in Sweden has been financed first of all by the state. Different political decisions over the years have made the contribution of means for the cultural sector fluctuate and for that reason created an unstable financial climate for the built heritage. It is true that in times of economic recessions the financial support have increased in order to compensate a reduced labour market within the building sector. This gesture has not always had as good effects as intended for the historical buildings since this kind of maintenance work demands skilled craftsmen, more specialized in the traditional building methods than in new construction. Already in 1991 an official report was published that had investigated alternative solutions to government subsidy, such as tax relief and private funding, without having any real impact on future political decisions.

In the recent financial plans from, 2002 until 2005, the Swedish Government had to make major cut downs in the national budget for already planned renovation projects. During the same time period private companies (trade and industry) more or less lost their tax relief on financial supports to culture activities and a precedent verdict was approved in the Government Court 2000, Pharmacia Upjohn sponsoring of the Royal Opera. But in order to guarantee the safety of the built heritage in Sweden and increase the stability, long-ranged financial plans are necessary. This could be attained if the financial burden to a greater extend would be divided between State and the private companies by for example recreating tax relief in order to increase the private funding.

Under the motto "to secure our history for the future" the German private Foundation DSD (Deutsche Stiftung Denkmalpflege) was founded in 1985 by 23 of Germans most influential companies on the initiative of the federal conservator of Hessen. The foundation works active in supporting conservation projects all over the country thanks to benefits form private companies and other private groups that take a considerable responsibility for the German heritage. In Demark there has always been a tradition for companies to support culture events through company foundations were private owners can apply for contribution for maintenance on historical buildings. The financial climate have recently made some of theses founds grow considerably and that is why government subsidy only covers a minor part of the actual building costs.

In Great Britain the government changed their fiscal policy and introduced new tax relief in year 2000 in order to stimulate the private industry to culture sponsoring. English Heritage is distributing the finances but many other private founds, such as National Trust, work active with maintenance and management in conservation projects. The financial situation for the built culture heritage in Norway and Finland is much similar to the Swedish one with mainly governmental subsidy. The question is weather the Nordic countries have something to learn from our neighbour-countries in the south in order to secure the financial situation for heritage by making it less dependent on changes in the political or financial climate.

Ever since the European Architectural Heritage Year in 1975 the construction firms, architectural consultants, structural engineers and other actors with commissions in restoration project in Sweden have become *experts* in building conservation. The development in the building industry, since the 1960ies, has created a shortage of skilled labour on all levels with the proficiency of working with historical buildings. Although the Swedish educational system today offers different post-graduate educations in building conservation, the financial situation with state funding often favours the most established firms. For that reason these companies and consultants lack the incentive to aim for low building costs in the conservation projects. If the financial burden to a greater extent could be divided between the state and the private financiers this would stimulate all involved actors to be more concerned about the expenses that the Germany model is a good example on. If practical financial models would be developed that are designed to improve the control of the projects this might even reduce the costs for building conservation.

The aim with this research study is to develop dynamical and general financial models designed to be tools fit to use in the practical building conservation and in this way guarantee the future for our built heritage. The models will be based on the results achieved from inventory studies and analyses of the financial structures for building conservation in six different European countries. These countries represents two groups were Great Britain, Germany and Denmark are the ones that have developed financial solutions that requires financial contributions from both private actors and state. In Finland, Norway and Sweden conservation projects first of all need sufficient means of government subsidy in order to be realised.

Method

This inventory study, presented for the first time in the Helsinki seminar in December 2005, is the first out of four parts that constitute the foundation for the research study to develop new finance models for the built cultural heritage. The project is planned to comprise following four studies and this report represent the initial inventory studies described under paragraph one below.

1. A comparative study of the financial support, or sponsoring, in twelve restoration projects from Denmark, Germany, Great Britain, Norway, Finland and Sweden completed in the time period of 2000-2004.
2. An inventory of state funding of the built heritage and its effects in Norway, Finland and Sweden from 1975 to 2004.
3. A methods study in order to develop practical models to take control of the building costs by increasing the educational level and improving the building management in Building Heritage.
4. Analyse study of what measures to take in order to engage the private groups (companies and donors) for a more active support of the Built Heritage.

The Diagram method used in the comparative study of the financial support (1) was developed during the analyse process in the licentiate report "Building preservation around the Baltic Sea" (Ingela Pålsson.Skarin, 2000). It is based on an evaluation method called *Goal-Free-Evaluation* (Scriven 1972) which employ both qualitative and quantitative analyse methods. This method means gathering data directly on the process effects and its effectiveness without being constrained by a narrow focused on stated goals for the actual process. In the licentiate study (Skarin, 2000) the qualitative facts about the process are obtained through interviews with a limited and defined group of people active in the project. The answers representing the majority are finally transformed into more readable graphical diagrams and becomes quantitative figures were structural patterns can be traces and analysed. The reason to use this model is first of all to maintain the evaluators objectivity by being independent of the goal itself, the restored buildings. With the experiences from the licentiate study were comparison studies were made between fifteen different restoration projects this strict and logical work model was most effective.

All interviewed persons in Denmark, Germany, Great Britain, Norway Finland and Sweden were initially contacted, they suggested renovation projects suitable for the study and gave us all necessary information on

other actors involved. In order to maintain the validity in the project descriptions, the questions were to be answered by three different persons, each representing one defined part in the project. The three interview parties were State authority (SA), Private financier (PF) and Recipient/ owner (RO). They received a questionnaire with ten questions and the persons were interviewed over telephone or during a meeting. In both situations a tape recorder was used. Two different renovating projects were described per country one represented the highest and the other the lowest financed, active during 2000-2004. The interviewed parties were free to choose between six answers in the questionnaires except for the last three questions these were to be answered in percentage. Six interviews were held per country and it added up to a total of 36 interviews carried out during 2004.

Results

One of the most obvious effects from the interview study was the distinction of building categories chosen in the two groups. The group representing divided financing, private and state, were represented by castles, churches and vernacular architecture. The other tree with projects mainly financed by government subsidy, Norway, Finland and Sweden, had chosen different kinds of early industrial building such as mills, power- and radio stations and cellars for the study. This effect could be a result of a deliberate focus from the financiers that in all cases first of all were the state. Other interesting results from the study will be presented on the seminar since this study has not yet been completed.

Discussion

The result from this first study will be guiding in what direction to continue with the project since my colleague Inger Strömberg decided not to take part in this project after the first interviews. For this reason I will not be able to carry through with all four part projects described but will probably continue with the analyse study (4) of what measures to take in order to engage the private groups for a more active support of the built heritage. My experiences from practice as an architect have given me experiences from Germany, Denmark and Sweden. The licentiate study with the survey of fifteen conservation projects around the Baltic Sea will also be useful for this study. Inger Strömberg is much better prepared for project two and tree since she has a long experience from her professional life as a building antiquarian at the regional authority working with applications for financial contributions to conservation projects.

Paper 3

*Conference CHRESP The 8th European Conference
on Research for Protection, Conservation and
Enhancement of Cultural Heritage
Ljubljana 10-12 November 2008.*

Conference *CHRESP The 8th European Conference on Research for Protection, Conservation and Enhancement of Cultural Heritage*, Ljubljana 10-12 November 2008.

New Finance models for the Built Cultural Heritage

Ingela Pålsson. Skarin Ark MAA, Tech. Lic

Division of Architectural Conservation and Restoration, Lund Institute of Technology,
Lund University, Box 118, 221 00 Lund, Sweden Ingela.palsson_skarin@byggark.lth.se

Abstracts

The extended definition of culture heritage today has increased the indispensable built legacy, reflected in an enhanced protection. Growing concern globally means new threats as armed conflicts, growth and nature catastrophes. The need for new financial solutions corresponding to the persistent expanding up-keep requests is imperative. Financial support available, developed spontaneously in the 20th Century are obsolete, geographically narrow and unfocused economical approaches, which requires upgrading. With the aim to suggest more sustainable solutions to cover the financial deficit, this paper investigates effects of private and public financing as a comparative study of 27 conservation projects from nine countries active 1990-2004. Pickard & Pickerill (1, 2) categorised financial supports but failed scrutinizing these effects in practice. This inductive analysis takes-off at the building sights evaluating the actual outcome of funding. Trupiano (3) emphasised origin of fiscal support with corporatisation. The advantage with pluralism amongst financiers is hence identified. To multiply financial sources, incentives for investment market, donors and private groups are crucial, why a broader assessment model on values applicable for management planning is presented. Diversified financing based on building requirements; basic, control and action, creates efficient use of sources. Local advocacy limit value turns, reaches youth and improves sustainability.

Introduction

Built cultural heritage is defined by what the spirit of time in society considers to be of an irreplaceable historical milestone and as result of previous social changes. Manmade constructed legacy can uphold this status as long as the remembrance function lasts or a mutual understanding is fulfilled for other vital utilities in nations. This means that any abrupt changes in the social structures might alter this intrinsic object value of the heritage and jeopardize its future prospects of existence. Armed conflicts or new boarder lines that lead to social upheavals may result in re evaluations and demolition due to new political opinions concerning history. Only the built legacy that still has a well defined value, on the merits of an active liaison to history, will be spared and pursue without interventions. Legal protections and listing of buildings have for this reason been introduced since the beginning of the 19th Century in Europe to secure the object values of the built heritage. In spite of all good intentions have the legal protections and restrictions developed not been capable of providing guarantees of endurance for the legacy due to lack of sufficient financial means. No form of government can single handed manage the financial responsibility caused by the persistent up-keep request when the heritage is struck by a value loss and no longer is considered of any obvious use for the contemporary society.

Finance support for the built cultural heritage available from funds and associations today have been developed as spontaneous benevolence in the 20th Century often caused by abrupt changes that threatened historical monuments, calling for immediate and united actions. Requirements to develop reliable financial solutions have been discussed on international conferences since the European Architectural Heritage year 1975 as recommendations to be solved according to governmental policy nationally. Drastic changes in the world have continuously augmented the legal protection, to cover various kinds of buildings, and widened the definition of indispensable built legacy. The ease to travel and the global economy have awakened the commitment to historical legacy worldwide. The continuously growing number of listed heritage and recent armed conflicts in the Middle East makes financial recourses insufficient. The obsolete economical approach suitable for European conditions in the 20th Century now calls for an upgrading. For this reason the need to develop new financial solutions has become imperative that corresponds to the persistent need. The aim with this study is hence to suggest sustainable fiscal models to cover the financial deficit requirement of the legacy. This will be done by investigating the features of the building conservation process and effects of dissimilar funding sources in practical conservation projects from nine countries. By analysing the insufficiency in present international financial support provided by funds and NPO's improvements of means and methods might be suggested. The constantly expanding conservation request calls for alternative fiscal solutions why furthermore the investment market and lottery funds will be surveyed.

Research studies on the financial support of built heritage are scarce but (Pickard & Pickerill 2002) study of the efficiency in the Granada Convention 1985 calls for attention were 70% of the member states ratified to advocated financial support for architectural heritage by all nations. The outline inventory of national financial support available in Europe fails to scrutinise the actual effects of the financial means in practice which is essential in judging the efficiency. The financial sources are briefly mentioned without connection to funding forms. To supplement previous findings this inductive analysis take-off at the building sights evaluating the consequences of funding in conservation projects, study how to re-establish control and to limit the expenses. This is done by stating the actual financial requirements of the edifices firm in an attempt to develop tailor made monetary allotment for two reasons; make use of the limited recourses disposed more efficient and secondly to market the support as an option for a future financier that possibly stimulates to incessant contribution. Since the built legacy also represent political aspects on keeping or rejecting heritage governed by the changing value has this obstruction made the goal of distributing finance indistinct. To invest in preservation works hardly ever means that the money will go to practical building works in full but becomes a frontage expecting to solve numerous of adjacent problems. Depending on the origin for advocating maintenance on a legacy, the actual reason might encompass everything from uniting nations, solve unemployment, educate craftsmen and to capacity building.

Ability relating to three dimensional heritages brings a variety of objectives for initiating conservations which correlates to the object value influenced by the personal relation to the legacy. The more challenges a conservation project contains, and is expected to cope with, the less efficient can a financial support become for actual building measures. Historically prestigious endeavour that leave little visible conservation traces at the sight might jeopardize the chances for future funding. Conservation works can not be executed once and for all, as in new construction, the task to solve is how to make presumptive financier continue their support. For this reason the intention in this thesis is to trace the triggers and locate all possible advantages for future investors and beneficiaries to gain on the practical building measures.

Experimental

This thesis has been developed over a time period of 11 years, but represents three work phases; 1997-2000, 2004 and 2008.

The financial model analyse is based on the outcomes of following five studies:

Study I: A process analysis of building conservation intrinsic factors; object value, team, legislation and finance effects. A field study of 15 conservation projects in progress (1990-2000) from Denmark, Germany, Lithuania, Poland and Sweden. Licentiate study (3).

Study II: A comparative study of the financial structures in twelve restoration projects from Denmark, Germany, Great Britain, Norway, Finland and Sweden in 2000-2004.

Study III: A sequential study of the financial support & methods provided by the private sector accessible worldwide for built heritage. Study analysis of the equivalent public support and means in Denmark, Germany, Great Britain, Norway, Finland and Sweden.

Study IV: An investigation of alternative fiscal solutions from the private sector; investment market, lottery funds and direct donations.

Study V: An analysis of the progression of value definitions on built heritage, introduction and testing of an alternative assessment model on values applicable from cultural value to management planning.

Study I; 1990-2000

The purpose was to establish a legible theoretical model of the practical conservation process, through conservation projects in progress, as a frame work for the finance study. The inductive analysis included five countries, each representing a unique building conservation tradition which gave wide spectrum. The three building categories; manor house, church and a vernacular architecture, three objects from each country, united the case studies that all were in progress between 1990 and 2000. During this decade occurred one of the major changes in Europe which began with the fall of Berlin wall in 1989. Since the work process of building conservation has a variable result dependent of the time when being realised, the evaluation method applied was inspired by the *Goal-Free-Evaluation* model (M. Scriven 1972 (5)). The method implies the use of both qualitative and quantitative analyse methods and enables the evaluator to maintain objectivity. This approach is signified by the data gathered directly on the process effects, and its effectiveness, without focusing on stated goals for the actual process. In the study the qualitative facts about the process were obtained through interviews with a defined group of people active in the projects, to ensure the validity, in all 113 respondents. The answers represented by the majority opinion, were finally transformed into more comprehensible graphical diagrams and became quantitative figures on a table were structural patterns of the intrinsic factors; *object value, team, legislation* and *finance* could be traced and analysed.

Study II; 2000-2004

The results achieved in the first survey were transformed in the follow-up research project focusing on the Finance factor alone that holds a unique position in the work process. Unlike the other three, Finance can be independent of nationalistic and political boundaries. This contributes to make finance studies general and relevant for any country. In this second phase a more detailed study was intended on what effect and impact different financial sources, public and private, might have in building conservation by studying how the roles of the actors and their involvement might be affected. By selecting conservation projects from Denmark, Germany, Great Britain representing private financial tradition for conservation,

equivalent projects were selected from Norway, Finland and Sweden all exemplifying public funding of building conservation. The research design was a redevelopment of the methods practised in Study I. The qualitative facts from interviews were again transformed into quantitative objective feasible circle diagrams to reduce the interpreters subjective influence on the results, all concealed in the six segments of the circle, equivalent to the number of answers per question. Each segment was numbered, from one to six, representing the categories to facilitate the interpretation. Through the questions the “cast list” of following five actors involvement; donor, driver, recipient, distributor and controller could be measured as and index. The initial expert interviews in the study were employees at the national board of antiquities in the countries who also suggested conservation projects suitable for the study. Two renovating projects were selected per country; one represented the highest financed conservation project and the other the lowest financed, all in progress during 2000-2004. To maintain the validity on descriptions of the building processes, the questions were to be answered by three different persons each representing one defined role. The three interview parties were *State authority* (SA), *Private financier* (PF) and *Recipient/ owner* (RO). Six interviews were held per country and 36 were carried out during 2004.

Study III; 2008

The necessary facts for the sequential study of private and public financial support of methods and figures are retrieved from publications, interviews and the Webb. The actors representing the private group are organisations operating from Europe, The US and the Middle East. Although they represent a limited number of countries, 11 in all, they may support and promote building conservation projects globally. This private group of funds, trusts, NPO's and advocacy groups are not private in the real sense of the world since they rely to some extent on public means. Membership fees are vital for international organisation as WHF or to receive or governmental subsidies. Heterogeneity also characterize the group since some have insufficient means to support conservation works other than their own estates, like the trust, or never is in contact with the practical work as the advocacy groups. Nonetheless are they all essential in the promotion and as role model for the global building heritage. The organizations were established in times when the built heritage suffered external threats and their foundations signify six time periods; industrialization (1885-1940), Post war (1941-1953), The void (1954-1964), The catastrophes (1965-1989) and the Merge (1990-). Methods used by the organisations to transfer financial means into conservation projects are many but close related to the individual organization only the NPO's have the capacity to work with all forms.

The equivalent analysis of public support and means in the countries is in the study represented by Finland, Norway and in Sweden. The national boards of antiquity handle applications and distribute grants to conservation projects according to available means in financial budgets. The authorities in Denmark, Germany and Great Britain handle the funding issues of built heritage in cooperation with private associations. Public financial subsidies are limited in number compared with the previous group but have immense impact when practised fore example as tax-exempt.

Study IV; 2008

The investigation of alternative fiscal institutions is primarily a litterateur study of relevant research papers from the filed of economy, literature but also interviews with established charity organizations and NGO's. In the two previous studies some of the existing public and private actors of finance that been investigated, already are committed to the national as well as the global built legacy. The merging factor in these groups mentioned in previous study is that the financier's motivation to continue supporting is the general concern for the built

heritage. Alas are their individual financial limitations hindering them to continue no matter ambition. For advocators of the built legacy it is essential to find alternative financial sources and develop incentives that would be favourable for the presumptive group of financiers. This study focuses on three alternative financial sources that to some extent are familiar with heritage funding. An improved understanding of their nature, aspirations and driving forces might bring more result in alternative solutions favourable for the legacy. The investment market, lottery funds and direct donations represents a heterogeneous group but what unites them is the absence of emotional involvement in investments. This professional attitude is what the heritage funding sector is missing today and for this reason might improved relations with these financial actors be the only conceivable solution to the financial deficit caused by heritage increase.

Study V; 2008

Already during the process analysis, Study I, the issue on heritage evaluation was scrutinized. In interviews with the respondents if alteration of value (object value) might occur on edifices subsequent building conservations, the content analysis of the answers provided four distinct categories on value; historical (1-3), utility, nominal and symbol. Since the outcome of the process analysis in the same study underlined the impact of object value this fifth study continues by investigating the progression of value definitions on built heritage over time. Charters from ICOMOs conferences provided significant information on the issue. Resemblances with the previous value categories contributed to the follow up test were three groups of respondents judged the efficiency of the assessment model on values called HUNS by comparing this one to the officially used Unnerbäck evaluation system.

The first group of 26 respondents was attending an international post graduate course, the CMHB, where the test was implemented during a practical exercise in evaluation of historical buildings from different time periods. The second occasion was with architect students with 7 respondents executing an assessment exercise on a residential area from the 1960ies and the last group of laymen with 9 respondents made the test just by applying the value scales on a local city hall from the 18th century.

Results

All studies have been used cumulatively and contributed to the following outcomes.

The first study showed that object value exercised the most influence over the conservation process. Objects with high legislative protection were conserved with more radical and modern methods and the listing actually had negative effect. Spirit of time and conservation tradition was much more decisive for the treatments chosen than the actual maintenance requirement of the building. The factor Finance was signified by three distinct sources; public-, private/public- and private means but only two effects could be traced in the conservation processes. For public funding the object were manor houses, restoration teams; experts, the financial flow; uneven with interruptions and the project time; 12 years in average. Significant for project funded by private means, or public-private funding, was that objects could be all three categories, restoration team; no experts, the financial flow; uneven with interruptions but also even/more intense and the project time; 6 years in average.

One of the most obvious effects in the second study was the distinction of building categories chosen in the two groups were manor houses, churches and vernacular architecture were all financed by private means. Projects with public means were limited primarily to early industrial building such as mills, power- and radio stations and cellars. This outcome could be

a deliberate choice from the financiers and relates to the dominating public funding of castle in previous study. Restraint of financial source might reduce the multitude of heritage conserved and can increase costs since a cartel tendency can occur among selected experts with contact to the authorities. The limitation in public funded is narrowing the actors group which reduces democracy. Finally the cast list of donor, driver, recipient, distributor and controller, for private funded project showed that a majority were different private groups which might reduce expenses caused by open purchase and to reduce project time due to private employment.

A majority of the private financiers in study III are dependent on external finance as membership fees, public means and voluntary work. The NPO's, RD and NYLC shoulder advocacy, fund and are self-sufficient. The initial idea of WHF was that all member states should feel as committed and contribute member fees to monuments at risk. To reach the same goal has a unifying effect, but tends to fade the further the distance. The traditional information routes might bring reflections of colonization, when implementing capacity building. Cutting new grounds globally might call for more dynamical units with local ties not a distant centralized administration.

In the UK the EH is semi-public and are actively marketing to secure membership fees and donations covering expenses on public and private heritage. The Danish authority is well supplied with funds from RD but only recently the authorities mistrusted the influential financier that theoretically can set the agenda for building conservations. Germany suffers from the back lash after the prosperous 1990ies with affluence of finance for heritage at risk in East Germany. For Finnish and Norwegian building proprietors a few recent changes indicate a future for private funding along with public subsidies primarily available today. The situations for the national antiquity board and national property board in Sweden are discouraging on all levels depending on fluctuating public subsidies.

Study IV with the brief overview of the established global investment market showed variations more or less risky profits from investments. Some might be adaptable for investments in the built cultural heritages but solution on the tax-exempt need to be solved. Established charity organizations, NGO have solved much of the problems heritages funds encounter world wide and collaboration would heritage sector gain on. Lottery funds have to expand the immense profits distribution, why not consider the heritage?

Study V showed that qualitative and quantitative historic values have prevailed through time, symbol value is a 19th century approach followed by utility value and nominal value twenty years later.

The tree test groups of respondents on the Unnerbäck (U) and HUNS (H) assessment models judged advantage and disadvantages of use and actors use preferences. The first two were showed that (U) positive *judgement* on historical values used by *architect* and *historian*. (H) was *quick* and *value improving/clear*, adaptable for *management planning* and utilizable by *investors*.

Conclusion

The extended definition of culture heritage creates indispensable built heritage continuously why new financial solutions for conservations are imperative.

The financial support available is insufficient, requires upgrading, depends on external finance and voluntary work. NPO's are self-sufficient.

Diversified financing based on building requirements; basic, control and action could be on way to create efficient use of sources.

Restrains on financial pluralism, public/private, may reduce multitude of heritage and increase expenses. Private funding appears to reduce expenses and limit project time.

The professional attitude in investment market, lottery funds and donors is what the heritage funding sector needs. To multiply financial sources, incentives for the private sector are decisive. Tax-exempt have effect for local advocacy groups which limit value turns and improve sustainability.

Object value has major influence and more wide-ranging assessment models are required. HUNS developed from the practical conservation might be of assistance for the marketing of heritage and management planning.

Acknowledgement

Thanks for financial support from
2004 Magna Bergvall Stiftelse
2007 Crafoordska Stiftelsen
2008 Formas

References

1. R. Pickard, T. Pickerill, *Conservation finance 1: Support for historic buildings*, Structural Survey 2002, 2, 72-77.
2. R. Pickard, T. Pickerill, *Conservation finance 2: Area-based initiatives and the role of foundation, funds and non-profit agencies*, Structural Survey 2002, 4, 112-116.
3. G. Trupiano, *Financing the culture in Italy*, Journal of Cultural Heritage, 2005 6/4, 337-343.
4. I. Pålsson Skarin, *Building preservation around the Baltic Sea with case studies from Lithuania, Poland, Germany, Denmark and Sweden*, 2001.
5. M. Quinn Patton, *How to use qualitative methods in evaluation*, 1987, California USA.

Appendix 1

Step 1 Analysing Heritage economics in practice 1990-2004

Study 1; 1997- 2000 and Study 2; 2004

1. Study 1; 1997- 2000

1.1 Introduction

This section outlines the holistic analysis of Step 1 describing 14 years of heritage economics practice and is based on two field studies. Study 1 was established during a unique era as the decayed, but still intact, built cultural heritage of Eastern Europe, had now become accessible to the West. Extensive sums of money were allocated by the neighbouring countries and exceptional building conservation ventures were launched, because these buildings represented former national possessions for the financiers.

The empirical field observations, of progressing building preservations in the study, were systematized as a qualitative-quantitative research methodology, thus using data obtained through interviews, during visits to the building sites. The outcome of the survey was presented as a licentiate study in 2000 *“Building Preservation around the Baltic Sea –a study of work processes through case studies from Lithuania, Poland, Germany, Denmark and Sweden”* (Skarin. Pålsson 2001). In this appendix the findings are reviewed, but this time with focus exclusively on finance.

The second follow-up; Study 2, is a qualitative-quantitative research methodological approach as well, with data obtained during interviews. The study was completed in 2004 (Skarin Pålsson 2004) and was in 2005 prepared as a conference paper, see Paper 2, titled *“A comparative study of the financial structures in twelve restoration projects from Denmark, Germany, Great Britain, Norway, Finland and Sweden in 2000-2004”* (Skarin Pålsson 2005). The outcomes were further developed in 2008 to define the tendencies in heritage economics practice 1990-2004.

To realize significant patterns from the two field studies’ facts and findings, new graphical diagrams and tables were drawn which have made further analysis possible. The result from both surveys then brought the hypotheses which have been of guidance for the follow-up study, to propose a new approach for augmenting fiscal resources for built cultural heritage; the heritage finance model.

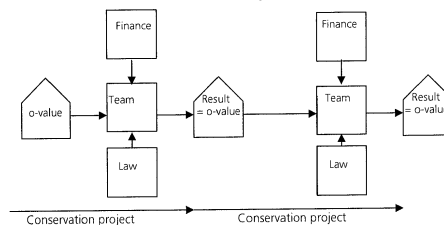

Figure 11.1 A process analysis of building conservation intrinsic factors; object value, team, legislation and finance. The theoretical model of the building conservation processes of Study 1 was visualised as successions of time. The four factors were the framework indexes, which rendered the comparative study of 15 conservation projects possible. The temporary object value (o-value) is the deciding factor whether a heritage site qualifies for building conservation, or not. The studied issues now were; "historic development" and an "object value analysis". The Team signifies different professionals and they are the ones who enable the process to take place, but according to a national praxis. The studied issues this time were; project outline, actors hierarchy, actors influence and actors relations. The legislation influences, Law, described the normative structure. Studied issues were now; legislation/year, the extent and impact on team. The Result finally, will be the foundation for the new object value. Studied issues were therefore; traditional materials/methods, traditional & modern materials/methods and reconstructions of traditional materials/ methods.

1.2 Study 1: Heritage economics of the time limit 1990-2000

The study's objective was to establish a legible model theory, to be used for the conservation process practical work, by analysing the intrinsic factors and their significances. The four factors; object value, team, finance and legislation, became the framework index, of these I have since focused deliberately and exclusively on finance. The factors' interactions, impact on the conservation process and its outcome, were finally decoded in the processes. This theoretical approach made possible the comparison of contemporary, but unique, conservation projects in five nations around the Baltic Sea.

To review projects in progress has been of utmost importance, since this enabled heritage site visits, but also in order to disclose the project participants' own intentions with and experiences of, their efforts. On account of the interviews with the involved parties, information could thus be obtained that under normal circumstances are lost, due to inadequate documentation of building conservations.

1.2.1 Choice of method and collection of data

The inductive analysis comprised five countries, each representing a unique building conservation tradition and this offered extensive spectra of approaches. The three building categories from each country; manor, church and a vernacular architecture united the case studies, which all took place between 1990 and 2000. The three diverse building types were selected since they represent a distinct object value level, here referred to as *legal value*. In this case the manor traditionally represents the one most highly regarded, followed by the church and on the lowest level, comes vernacular architecture. This sequence distinction thus reflects how the building protective legislation in many European countries has progressed. By choosing one representative from each legislative "level" or legal value in every nation, the object value could be interpreted in advance, since it is set according to a comparable framework. In this way, any additional values significance observed in the conservations would most likely represent judgements about the unique building category, representative for the individual nation. This approach in qualitative studies is referred to as criterion sampling in order to ensure reliability, that is; selecting cases which stand in relation to well known and congruous criteria.

Just as the factors *objective value* and *legislation* were defined in advance, the *Team* factor could be pre-set, since the conservation projects studied had time limitations, 1990-2000. A factor which is

possible to use since building preservations tend to follow trends since theoretical reasoning on building conservation are time bound. Variations in the projects that might still be observed, would consequently reflect the interesting discrepancies nationally in the field of preservation, based on teaching or education directions applied, ideological stances or the financial capacity in the countries. In order words, the way in which the survey was planned, all factors could be placed in a definable framework, except for the finance factor. The funding which would be applied could not possibly be predicted and consequently the characteristics of the heritage funding remained to be discerned.

While the work process, of building conservation projects, has a variable result, since it is influenced by existing conditions, by the spirit of the age and by the financial assets available, the evaluation method chosen was therefore inspired by the *Goal-Free-Evaluation* (Scriven, M. 1972). This method implies the use of both qualitative and quantitative analyse methods and enables the evaluator to observe objectivity. This approach is signified by the fact that all data are gathered directly from the process effects, and its effectiveness on site, without focusing on stated goals for the actual process. In the licentiate study the qualitative facts about the process were obtained through interviews with the projects' participants. To ensure the validity, eight active participants in every project were questioned and this resulted in a total of 113 interviews with respondents in five countries. The answers signified by the majority opinion, in percentage points, were finally statistically transformed into a clear graphical diagram. Here the findings became quantitative figures on the conclusive graphical chart, (see table GC 1). This table outline revealed the structural pattern of the 15 conservation projects, based on the four factors; object value, team, legislation and finance, which then could be traced and analysed.

The outcome of the study, when reading the table based on the four factors alone, showed that *Object value* had a strong impact over the conservation process and buildings with a high legislative protection were often conserved by means of more drastic and modern methods, which is why their high protective ranking actually had a negative effect on the original constructions. The penetration of the factor *Team* was less distinct, however the five variations reflecting the countries characteristics, were evident and they could be evaluated in relations to the two perspectives; *completed projects* and *uncompleted projects*. The Danish building conservations in this case proved to be equivalent to the standard for *completed projects*, while the Lithuanian ones were identical to *uncompleted* conservations. Finally, it seemed that the spirit of the time and the conservation tradition nationally, were the most decisive for the conservation conducts chosen and it was not consistent with what the maintenance requirements of the historic buildings actually were.

For further analysis in 2008, focusing on heritage economics alone, limited the study to the factor *finance*. This was why following research question was initially set up; *What distinctive finance structures are found in the building conservation projects studied and how can the relation to the object value, team and legislation factors be described?* The factor *Finance* revealed three distinct funding sources; public-, private/public- and private, however only two obvious effects could be traced in the conservation processes, which were; public and private funding. The following section describes how the continued study of the conclusive

graphical table developed, in order to analyse heritage economics in practice.

1.2.2 Application in study

From the building projects in the field study as early as 2000, the variation of the factor finance as regards observation and measurement, was defined through an inductive analyse of facts retrieved from the respondents in the interviews, and were first coded into main categories. The following four main categories were possible to distinguish in the answers.

1. Finance source public/private (%) of total sum of funding
2. Finance amplitude/project time (financial flow and character)
3. Finance quality (reliability, stability, intermissions)
4. Finance relation to team (actors influence over financial means)

To identify the *financial source* a quantification of the qualitative facts available from the projects made it possible to set up the following three variables:

- A. Finance source public 100%
- B. Finance source public (>50%) and private (<50%).
- C. Finance source private (>50%) or public (<50%)

In the study of the categories: *Financial amplitude/project time* and *Financial quality*, two groups could be indentified. Group 1 referred to projects with financial flow which were unstable and those in Group 2 were more stable. The two forms then were graphically illustrated as curves in an x/y diagram, with the time span on the x-axis while intensity; amplitude and interruptions, were easily identifiable on the y-axis.

1. Finance with high amplitude, with intermission in financial flow.
2. Finance with low amplitude or constant financial flow, without intermission.

In order to reduce the amount of variables and to create legible patterns, *Financial resource* and *Financial amplitude/quality* were combined according to the renovation projects from the survey. The following five groups, below, were set up to illustrate the factor *Finance*; the capacity of heritage funding, in the conservation projects as studied and outlined in the conclusive graphical table of the licentiate study 2000, (table GC1).

Public finance source

- 1:A Finance with high amplitude with intermission in financial flow + Finance source public (100%)

Mixed finance source

- 1:B Finance with high amplitude with intermission in financial flow + Finance source public (>50%) and private (<50%)
- 2:B Finance with low amplitude or constant financial flow, without intermission + Finance source public (>50%) and private (<50%)

Private finance source

- 1:C Finance with high amplitude with intermission in financial flow + Finance source public (<50%) and private (>50%)
- 2:C Finance with low amplitude or constant financial flow, without intermission + Finance source public (<50%) and private (>50%)

Variables from survey:				1:A	1:B	2:B	1:C	2:C
Li Manor				x				
Li Church								x
Li Vern. Arch				x				
P Manor				x				
P Church				x				
P Vern. Arch								x
G Manor					x			
G Church							x	
G Vern. Arch					x			
Dk Manor							x	
Dk Church					x			
Dk Vern. Arch							x	
S Manor				x				
S Church						x		
S Vern. Arch						x		

Table 122.1 The outcome from the 15 studied conservation projects. Financial resource and Financial amplitude/quality here have been combined to reveal the funding characteristics of the projects studied. Public finance source (1:A), Mixed finance source (1-2:B) and Private finance source (1-2:C).

With the intention of making these findings useful for future heritage economics, the tendencies observed in the study; that distinct correlations between the finance sources and process effects exist, call for further studies in order to explain the reason why. Since the structural pattern in the graphical diagram, table GC1, exposes all relations between the registered effects, based on *object value-team-legislation-finance* in 15 conservation projects, on an general level as discussed, yet the table allows a detailed analysis as well. In other words, it permits scrutinizing of how one factor's individual variations, such as the three registered monetary sources and funding flow for *finance*, stand in relation to the other factors.

The finance flow of amplitude/intermission/continuous, in this case is hardly relevant for the future heritage economics, while referring to the unique conditions in the projects. It is far more urgent to understand the finance sources in contractions since these will be re-occurring. For this reason, the re-structuring of the findings, this time (tables 122.2, 122.3) were set up for exposing the perspective of the three identified finance sources:

- Public funding (A) - represent 1:A
- Mixed funding (B) - represent 1:B, 2:B
- Private funding (C) - represent 1:C, 2:C

Financial source A. Public		Financial source C. Private	
Frequency;	33% of all projects	Frequency;	33% of all projects
B. category;	manor 60%	B. category;	40% church, 40% Ver.arch
Countries;	Poland 66% Lithuania 66%	Countries;	Denmark 66%
Object value;	A, listed buildings	Object value;	B, Exterior and interior
Team;	Practical education (I) Aim; to conserve (J) Recreate (A)	Team;	Practical education (I) Aim; do the job (J) Adaption for new use (A)
Result (B);	12 year process in average R2, traditional and modern material used.	Result:	6 year process in average R1, traditional materials only

Table 122.2 Effects registered in the conservation processes when the projects were funded either by public (A) or private (C) means, based on facts from table G.C1.

Financial source B. Public/Private	
Frequency;	33% of all projects
B. category;	40% church - 40% Ver.arch
Countries;	Germany 40% Sweden 40%
Object value;	A, B
Team	Practical education (I) Aim; do the job (J) Secure construction, money (A)
Result (B):	7,4 year process in average R3, reconstruction

Table 122.3 Registered effects in the conservation process in projects, which had a mixed funding source, facts from table G.C1. Similarity to the process of privately funded conservations explains why the mixed funded ones will from now on be treated as privately funded as well.

1.2.3 Results and future guidance

In order to shed more light on and explain the obvious differences between the processes in building conservations found in the study, when finance sources were changing between public, mixed or private, a direct comparison of the forms was essential.

The distinct correlations between public funding (A) and process effects which exist, illustrated in Table 122.2, show that; manors are selected and the form is most common in Lithuania and Poland. The team has practical experience of building conservation, the intention or aim to conserve and they are initiated for recreating the historic buildings. Both traditional and modern methods are applied in the projects, which on average last for 12 years. On the other hand, in privately funded projects (C) churches or vernacular architecture and Denmark, are here in the forefront. The team, with practical experience of building protections, aims to do the job by adapting built heritage for new utilization, which is based on traditional measures, in projects lasting for 6 years.

Finally, in the mixed funded (B) conservation projects (Table 122.3) it is shown that these coincide in many aspects with the ones privately funded, though discrepancies exist. For instance that; Germany and Sweden frequently practice the form, the aim is to secure constructions, available funding initiates the projects and with reconstructions as usual result. However, since national distinctions are less relevant for the conservation process and to *secure constructions* is an initial stage of adaptation, signifying the privately funded ones, only their result, that is; R1 to R3 differs. Yet, when considering that the divergence between public and private financed project is far more distinct for this reason private and mixed funding will both be treated as privately funded projects (Table 122.4).

The discrepancy in project length between public and private sources cannot be explained merely by the dominance of manor houses in the public group. It is true that they represent complex structures, which demand high craftsmanship skill, and thus are time consuming to maintain. Nevertheless, the fact is that churches often have far more complicated constructions than manors, with their towers or vaults. Additionally churches are often mixtures of building phases of more or less successful rebuilding attempts. The financial flow in the same way cannot be used for explaining the project length since the amplitude/intermission (1), which could be considered less advantageous, actually was in majority in the private funding group (mix-private) by 6 to 4 (Table 122.1). To argue that prolonged project time should be due to the manor house dominance among the publicly funded project therefore would be inaccurate and must have other grounds.

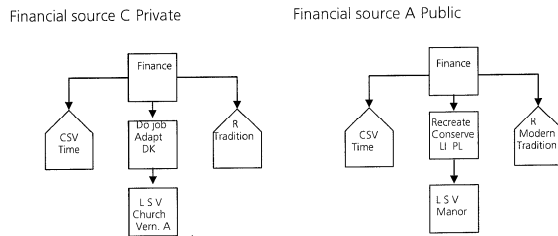

Figure 12.2.4 Illustration of the registered effect in the conservation processes whether privately, private/mixed 1:B, 2:B, 1:C, 2:C, or publicly funded (1:A).

The private funded projects, including the mixed funding, were signified by;

1. The financial flow makes the projects progress fast to completion.
2. No limitations in funding objectives; all building categories represented
3. Initial intention; adaptation for new use
4. Aim in team; do the job - a pragmatic approach to the conservation task
5. Result tendencies; protective measures of traditional (empirical) kind
6. Finance from representative for Denmark

The public funded projects were signified by;

1. The financial flow makes the projects progress slow to complete.
2. Limitations in funding objectives; only listed building; manors
3. Initial intention; recreate or restore to former appearance
4. Aim in team; to conserve the building -status quo
5. Result tendencies; protective measures of modern and traditional kind
6. Finance form representative for Poland and Lithuania

The two funding sources discerned; public and private, had individual effects on the building conservation processes studied, but the question is if this might affect the quality or outcome of the conservation works as well. As discussed previously, the matter of *accurate building conservation* is under the influence of the individual consensus in each nation. The patchwork of historical layers on the monuments, added over the centuries, also implies that the conservation methods are time documents. For this reason, our generation may not be able to claim that we know how to protect the built legacy accurately, regardless of all the advanced techniques we have in our possession, simply that we can only offer new traces from our time, adding to the historical layers. The *accurate building conservation* is most likely impossible to achieve and

the limiting time-reliant consequences might be even more obvious, if the influence over building protections is decided by small groups of experts, with limited perspectives or representing the outcome of discussion in mixed groups. Nevertheless it is certain that without the preservation attempt the built cultural heritage will not last, which is why a stable heritage funding is fundamental. Public funding in this case represents one single funding source, while private funding on the contrary refers to plenty.

The simplicity anyone has to relate to built cultural heritage, since it is three dimensional, is a fact that could provide objectives among groups to become involved in its support, when heritage is properly marketed, since this will direct how it is valued by society. To strengthen the object values may in other words be the tool to consider when it comes to heritage funding, just as it is the basis for the commencement of conservation projects. The more groups that become involved in conservation projects clearly means less dominance only by a few and perhaps becomes more advantageous for historic buildings. Important decisions, to a larger extent then, will be agreed on by more parties, thus for the common good. A more democratic approach might improve the chances of involving even the younger generations, which would have a direct effect on future heritage economics.

The outcomes from Study 1 required further testing and the hypotheses to be verified in the next studies were:

- Project funded by public funding, i.e. one financier, may also imply a limit in the number of actors involved, and thus be unfavourable for the built heritage.
- Public financing indicates restrictions in the selection of what built heritage to conserve since a limited group decides what is the correct building to fund; an undemocratic and time-reliant approach.
- Private funding primarily initiates adaptation for new use, fully intends to carry out the job and this funding is significant for Denmark.
- Public funding primarily initiates recreating earlier appearance and with the aim of conserving the building

Out of the conjectures discerned, the issues to investigate in the second follow up case study of building conservations; Study 2, had two objectives. Firstly to scrutinise if publicly funded projects would also limit the number of actors involved, which is proved unfavourable for the building protection since it affects the democratic conservation process and the need to reach future generations. Secondly, the objective was to see if it could be verified that public subsidies mean restrictions in the selection of what heritage to preserve.

2. Study 2; 2004

2.1 Study 2 Time frames of heritage economics 2000-2004

The results achieved from the first survey were transformed into the follow-up research project, focusing on the finance factor alone that holds a unique position in the work process of building conservations. Unlike the other three factors; object value, legislation and team, finance, such as heritage funding, could be independent of national and political borders. This makes finance studies wide-ranging and relevant for any country, not least when considering the trans-frontier heritage funding of today. For this second case study, as regards to verifying or falsifying the observed effect that distinct correlations between the two finance sources and process effects exist, as registered in Study 1, the following research question was set up: *What significant effects can be discerned in the conservation project funded by public or private means, with respect to actor's involvement?*

2.2 Choice of method and collection of data

The more selective second survey intended to explore possible differences concerning actor's involvement and funding objectives in relation to building types, in preservation projects, when funded either by public or private sources. With the support of *an ideal cast list*, of the participants implicated in the heritage funding dialogue, their involvement, just as their absence in the individual projects could be registered. The ideal cast list in this way became a comparative index to observe in order to say to what degree the group of actor varied in the conservation ventures.

In addition to Study 1, where the finance source had not been possible to determine beforehand, the funding source was here of major importance and as far as possible was to direct this Study 2. Selection of conservation projects from Denmark, Germany and Great Britain, was intentional, since the conservation cases in this way were likely to have private finance sources since private funding, or mixed private-public, as traditionally applied in these nations. For the same reason projects from Norway, Finland and Sweden were chosen since here public heritage funding is most common.

The research design was a re-development of the methods already established in the licentiate study of Study 1. The qualitative and emotionally tinted facts from the interviews were in this way once more transformed, while coded. However, this time the data was transferred into objectively feasible quantitative and circle diagrams, in order to reduce the interpreter's subjectivity to influence the results. The outcomes in this way were concealed in the six segments of the circle, which were equivalent to the number of answers, or variables referring to actor categories per question, obtained from the respondents. Each circle segment was numbered, from one to six, in clockwise order, and thus represented the answers or categories to ease the interpretation. Through the questions the "cast list" of five actor categories involvement; *donor, driver, recipient, distributor* and *controller*, could be registered since they are used as an index.

The first expert respondents interviewed in the study were authorities or member of staff at the national heritage boards in the respective countries. With their broad knowledge of issues concerning domestic preservation projects and their funding, the authorities proposed projects suitable for the study. The case projects in this way

can be said to correspond in a better way to what the authorities considered to be *accurate building conservations*, and representing sites thus of a national significance, as opposed to if the cases were to be selected by myself, a foreigner. Two conservation projects were chosen for each country, which made a total of 12 and all of them should be taking place during 2000-2004. Additionally, one of these cases represented the highest and another, the lowest financed conservation.

To maintain the validity in descriptions of the building processes, the questions were to be answered by three different persons, each representing one defined role or position in the heritage funding dialogue. The three interview parties were State authority (SA), Private financier (PF) and Recipient/Owner (RO). The questionnaire was answered by the respondents over the telephone or during a personal meeting, taped and finally rewritten in text. No translation assistance was necessary for the interpretation since the languages were German, English, Danish and Swedish. Six interviews were held per country and it added up to a total of 36 interviews carried out during 2004. No further studies could be carried out until 2008, but the preliminary results were presented at the International Expert Seminar on the Economics of Heritage Preservation in Helsinki, Finland, in 2005 (Paper 2).

One of the most obvious findings from the survey was the distinction of building categories in the two groups chosen. Manors, churches and vernacular architecture were all represented among the privately financed. Projects with public funding, on the other hand, were limited while primarily consisting of early industrial buildings, such as mills, power-stations and radio stations. This effect could be a result of a deliberate choice related to a specific program from the financier's part and correspond to the dominance of public funding for manors, as revealed in Study 1. Finally the cast list; donor, driver, recipient, distributor and controller, for private funded projects revealed that four out of five roles were cast by different private groups. In the publicly funded BC projects the limitation of actors' involvement was obvious, as all four out of five roles were cast by the same state authority.

2.3 Application in study

Here follows the methods used to interpret the diagram results transformed into numbers (Skarin Pålsson 2004).

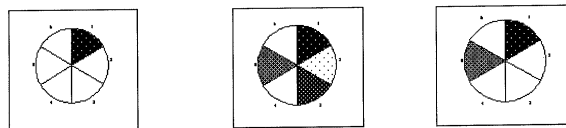

Figure 23.1 The qualitative facts from interviews were transformed into quantitative and objective feasible circle diagrams to reduce the interpreters' subjective influence on the results, all concealed in the six segments of the circle, equivalent to the number of answers available per question for the respondent.

The organization of data, outlining different actor categories involvement in privately or publicly financed conservation project of national groups, is structured in groups. The countries with private heritage funding; Denmark, Germany and Great Britain, are called

Group 1. The Group 2 refers to the corresponding public heritage funding which is most practiced of Finland, Norway and Sweden. Two conservation projects were selected per country; one represented the highest financed (h) conservation project and the other one the lowest financed (l) and all of them were in progress from 2000 to 2004. Two table analyses; A and B have here been carried out to investigate significant patterns in the findings and to shorten the tables presented, the following abbreviations are used in all tables.

Group 1 Private finance (G1)	Group 2 Public finance (G2)
DKh- Danish project, high financed	Fh Finnish project, high financed
DKl- Danish project, low financed	Fl Finnish project, low financed
Gh German project, high financed	Nh Norwegian project, high financed
Gl German project, low financed	Nl Norwegian project, low financed
GBh Great Britain pr. high financed	Sh Swedish project, high financed
GBl Great Britain pr. low financed	Sl Swedish project, low financed

Since some of the answers of the questions asked, never produced any useful results, such as 2, 8 and 10, these were excluded from the table analysis. The numbering of the actors choices is individually set per question and for this reason presented in brackets after each question.

1. What **actors** were involved in the financing of the project?

(1. State, 2. Donor, 3 Driver, 4. Recipient, 5. Distributor, 6. Controller)

3. What did the **donor** structure look like in the project?

(1. Private, 2. State, 3. Foundation, 4. Private+State, 5. Church, 6.Others)

4. Who was the **driver** in the project?

(1. Media, 2. Recipient, 3. State, 4. Company, 5. Church, 6. Associations)

5. Who was the **recipient**?

(1. Private, 2. State, 3. Church, 4.Foundation, 5. Associations, 6. Others)

6. Who **distributed** the financing in the project?

(1. Authority Central, 2. Authority Regional, 3. Authority Local, 4. Church, 5.Associations, 6.Others).

7. Who **controlled** the project?

(1. Authority central, 2. Authority Regional, 3. Authority Local, 4. Church, 5. Associations, 6.Others).

9. How was the project financing divided (%) between Private and Public means? (1. Private financing, 2. Public Financing)

	1 Actors	2 Donor	3 Driver	4 Recipient	5 Distributor	6 Controller	7	8	9 Financier	10
DKh	124	4	34	2	1	15	1	1	1	2
DKl	124	4	346	2	5	135	16	1	1	2
Fh	14	4	46	34	1	1	12	1	1	2
Fl	14	4	4	3	1	1	2	3	12	2
Gh	124	4	346	26	23	236	1235	1	12	2
Gl	1234	4	136	26	3	56	2345	1	1	2
GBh	1234	4	34	6	1	6	15	1	1	2
GBl	124	4	1	2	12	6	25	1	1	2
Nh	146	4	2	236	1	23	23	1	2	2
Nl	14	4	2	23	1	2	2	1	2	2
Sh	1456	4	23	3	45	125	2	1	12	2
Sl	146	4	2	6	5	2	25	1	2	2

Table 23.2 Analyse A; No distinct pattern occurred when the project was arranged in alphabetic order.

Analysis A

As a first approach the table was studied according to what *similarity* and *discrepancy* may exist between the groups, but since no distinct pattern was revealed, the table 23.2 was reorganized.

1. What actors were involved in the financing of the project?

Similarity:

- State (1) and Recipient (4) involved in all projects.

Discrepancy:

- Donor (2) only registered in Dk, G, GB projects.
- Driver (3) only registered in G and Uk projects.
- Distributor (5) only registered N, S projects.
- Controller (6) only registered in N, S projects.

3. What did the donor structure look like in the project?

Similarity:

- Private +State (4) involved in projects to 50%.
- Foundations (3) involved in projects to 50%.

Discrepancy:

- Private (1) only registered in GB projects.
- State (2) only registered in N, S projects.
- Others (6) only registered in Dk, F, G projects.

4. Who was the driver in the project?

Similarity:

- Recipient (2) involved in projects to 58%.

Discrepancy:

- State (3) only registered in F, N, S projects.
- Company (4) only registered in F projects.
- Organisations (6) involved in G, GB, N, S projects.

5. Who was the recipient?

Similarity:

- Private (1) involved in projects to 58%.

Discrepancy:

- State (2) only registered in G, GB projects.
- Church (3) only registered in G projects.
- Foundation (4) only registered in S projects.

- Organisations (5) only registered in Dk, S projects (+ Grimeton?).

6. Who distributed the financing in the project?

Similarity: none

Discrepancy:

- Authority, C (1) only registered in Dk, F, S projects.
- Authority, R (2) only registered in G, N, S projects.
- Authority, L (3) only registered in Dk, G, N projects.
- Organisations (5) only registered in Dk, G, S projects.
- Others (6) only registered in G, GB projects.

7. Who controlled the project?

Similarity:

- Authority, R (2) involved in projects to 75%.

Discrepancy:

- Authority, C (1) only registered in Dk, F, G, GB projects
- Authority, L (3) only registered in G, N projects.
- Church (4) only registered in G projects.
- Organisations (5) only registered in G, GB, S projects.
- Others (6) only registered in DK projects.

9. How was the project financing divided between Private and Stat?

- Private financing 50% (including Private and State, see above)
- State financing 50%

Analysis B

By reorganizing the table according to financial sources; private- Group 1 and public- Group 2, previously concealed similarities appeared within the groups appeared. With this new structure it was possible to reduce the numbers that is the variety of actors, in favour of the ones signifying the majority for the group and this enhanced the tendencies. The new sets of categories now representing the two groups was defined as “character”.

1. What actors were involved in the financing of the project?

Group 1: 124

State, donor, recipient are all considered playing an active role in the financing.

Group 2: 14

The *donor* is the same as the state so one actor less.

3. What did the donor structure look like in the project?

Group 1: 34

Foundations and *private+ state* signify the donors.

Group 2: 2

State was in dominance.

4. Who was the driver in the project?

Group 1: 2

The *recipient* has to be most active in order to get a conservation project running.

Group 2: 3

State in dominance and has made an active choice of project to finance.

5. Who was the recipient?

Group 1: 1

The *private* owner who applies for funding for a conservation project.

Group 2: 1

The *private* owner, no matter financing source.

6. Who distributed the financing in the project?

Group 1: 6

Others is represented by foundations that contribute with financial means

Group 2: 2

Regional authority holds a key position when governmental subsidies are spent.

7. Who controlled the project?

Group 1: 15

State and *others* means that the central authority has an important say although the main financial source consists of private means from foundations.

Group 2: 2

Regional authority holds a key position when governmental subsidies are spent.

9. How was the project financing divided between Private and Stat?

Group 1: 1

Private financing.

Group 2: 2

Governmental subsidies from *state*.

Group 1	1 Actor	2 Donor	3 Driver	4 Recipient	5 Distributor	6 Controller	7	8 Financier	9	10	
DKh	124	4	34	2	1	15		1	1	1	2
DKl	124	4	346	2	5	135		16	1	1	2
Gh	124	4	346	26	23	236	1235	1	12	2	
Gl	1234	4	136	26	3	56	2345	1	1	2	
GBh	1234	4	34	6	1	6	15	1	1	2	
GBl	124	4	1	2	12	6	25	1	1	2	
character	124		34	2	1	6	15		1		
Group 2											
Fh	14	4	46	34	1	1	12	1	1	2	
Fl	14	4	4	3	1	1	2	3	12	2	
Nh	146	4	2	236	1	23	23	1	2	2	
Nl	14	4	2	23	1	2	2	1	2	2	
Sh	1456	4	23	3	45	125	2	1	12	2	
Sl	146	4	2	6	5	2	25	1	2	2	
character	14		2	3	1	2	2		2		

Table 23.4 Analyse B; arranged according to financial source private, group 1, and public group 2 and similarities within the groups were evident.

According to table 23.4 the distinction in tendency between the private Group 1 (G1) and the public Group 2 (G2) sources, following a pattern of actor involvement was revealed.

1. More actors involved in G1 than in G2 projects; donors make the difference.

(G1) *The donor is an important distinction who makes more actors, by number, involved in the private financed processes. The donor often has a say when it comes to adapting new functions in the built legacy, with their private money.*

(G2) *It becomes a two-part discussion between recipient and the heritage authority, who distributes public funding.*

3. The donor foundation and private+state in G1, while the state dominates in G2.

(G1) Two main sources are required for the private funded projects to succeed; private+ state as well as foundations that can indicate a more democratic process with disputes and discussion. (G2) When only public means are distributed a more uniform idea is behind the contribution.

4. The driver is the active receiver in G1 and in G2 the driver is also the financier.

(G1) The driver is the private owner who is engaged in order to receive grants. (G2) The engagement for public means is based on a decision made by authorities; the driver is an employee at the heritage authority office.

5. The recipient is the private owner in G1 and in G2 as well, regardless of financier.

6. The distributor in G1 are foundations and in G2 the authority in charge.

(G1) The main financier plays an active role in the projects such as foundations of private means, (G2) while the regional authority is for the public support. The central authority is still participating but might have a weaker position than the distributing regional authority, who has the heritage funding as a "control tool".

7. The controller in G1 is divided into two parties; the central authority and the foundation. Only one controller is required in G2's.

(G1) The central authority is always involved since the active financier is a private representative. (G2) The regional authority handles the control on the local level in a project, when subsidised by governmental authority.

9. The financier.

No new findings.

2.4 Results and future guidance

What is significant for the actors' involvement in private financed projects (G1) could be explained as follows. The *donor* is an important distinction from the G2 projects and this makes more actors, by number, involved in the private financed processes accompanied by *state* and *recipient*. The donor often has a say when it comes to adapting new functions in the existing building, due to their private finance support. Two main funding sources are required for the private funded projects to succeed; *private+ state* and *foundations*, which can indicate that it is a more democratic process, encouraging to disputes and discussions. The *driver* is the *private owner* who is actively engaged in order to acquire funding. The main financier plays an active role as *distributor* in the projects, such as the foundations of private means. The central authority is always required and participates since the financier is an active private party.

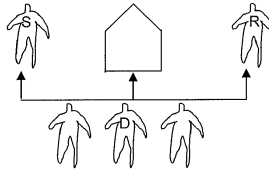

Table 24.1 Actors involvement in private financed project, Group 1; state, recipient and donor.

The private funded projects were signified by the following:

- The funding form engaged more actors, more donors, in the projects
- The state is always present and can influence the projects, no matter financier
- The project initiator, driver, is the owner or recipient
- The donors' incentives for funding also affects the outcome
- No limitations in funding objectives; all building categories represented.

The significance of the actor's involvement in public financed projects (G2) could be explained as follows. It is a two way discussion between *recipient* and the heritage authority as the *donor*, who is distributing public grants. When only public means are allocated to projects, a more uniform idea is behind the contribution. The inducement for public means is based on a decision made by authorities; the *driver* is a public employee. The central authority is still participating but might have less influence than the *distributing* regional authority has since using the finance as a "control tool". The regional authority handles the *control* on the local level in project subsidised by governmental grants.

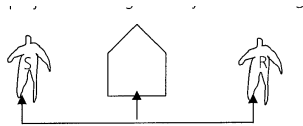

Figure 24.2 Actors involvement in public financed project, Group 2; state (S) and recipient (R).

The public funded projects were signified by the following:

- The funding form involved less actors; a dialogue between recipient and state
- The project initiator, driver, is the same party as the donor; less innovative.
- The distributor of funds and the controller of projects are identical; regional authorities
- Limitations in funding objectives; only early industrial buildings; so called "program buildings".

Analyse A

1. Actor	G1	G2
1. State	x	x
2. Donor	x	
3. Driver	x	
4. Recipient	x	x
5. Distributor		x
6. Controller		x

3. Donor	G1	G2
1. Private	x	
2. State		x
3. Foundation	x	x
4. Private/state	x	x
5. Church		
6. Others	x	x

4. Driver	G1	G2
1. Media		
2. Recipient	x	x
3. State		x
4. Company		x
5. Church		
6. Assoc.	x	x

5. Recipient	G1	G2
1. Private	x	x
2. State	x	
3. Church	x	
4. Foundation		x
5. Assoc.	x	x
6. Others		

6. Distributor	G1	G2
1. C- Auth.	x	x
2. R- Auth.	x	x
3. L- Auth.	x	x
4. Church		
5. Assoc.	x	x
6. Others	x	

7. Controller	G1	G2
1. C- Auth.	x	x
2. R- Auth.	x	x
3. L- Auth.	x	x
4. Church	x	
5. Assoc.	x	x
6. Others	x	

Analyse B

Actor	G1	G2
1. State	x	x
2. Donor	x	
3. Driver		
4. Recipient	x	x
5. Distributor		
6. Controller		

Donor	G1	G2
1. Private		
2. State		x
3. Foundation	x	
4. Private/state	x	
5. Church		
6. Others		

Driver	G1	G2
1. Media		
2. Recipient	x	
3. State		x
4. Company		
5. Church		
6. Assoc.		

Recipient	G1	G2
1. Private	x	x
2. State		
3. Church		
4. Foundation		
5. Assoc.		
6. Others		

Distributor	G1	G2
1. C- Auth.		
2. R- Auth.		x
3. L- Auth.		
4. Church		
5. Assoc.		
6. Others	x	

Controller	G1	G2
1. C- Auth.	x	
2. R- Auth.		x
3. L- Auth.		
4. Church		
5. Assoc.	x	
6. Others		

Table 2.2.3.6 shows a complete overview of the table analyses A, B, C. Here the six ac

Table 24.3 The two tables outline the complete analyses of A and B. The six actor groups are this time placed in the table heads while the answers/categories are instead positioned in the left columns. Groups, 1 and 2, are revealed to the right. Analysis A is here presented as previously with all answers available. The majority abstraction improved the legibility to discern the tendencies of the actor's involvement as illustrated in B and C.

3 Heritage economics in practice 1990-2004 in summary

3.1 Study 1; 1990-2000

The objective of Study 1, was to establish a legible model theory, to be used for planning improvements of the building conservation process in practice, by analysing its intrinsic factors and their significances (Skarin Pålsson 2001). The four factors; object value, team, finance and legislation, were therefore used as framework index. To transform progressing conservation projects from practice on the sites, into theory, would enable the analysing and testing of what actual effects individual undertakings on national policy level might have for the built heritage.

For instance, the future effects of the undertakings made by Lithuania and Poland could have been judged, as they enhanced the heritage *legislation* in order to protect their historic buildings. This action has its grounds since the heritage authority here wished to regain control over the two nations' intact medieval city centres when many foreign companies in the mid 1990's rapidly began to set up their businesses. In the same way the outcome of Swedish and Danish investments in the *team* could be better understood, which were launched to improve building conservation through training traditional craftsmanship. The merger of Germany made the development of new *finance* solutions most urgent, in order to secure the protection of neglected built heritage in their new east states. This might have become less time reliant if its effects had been possible to predict.

Study 1 arose during the unique era of the 1990's as the decayed, but still intact, building legacy of Eastern Europe, at last became accessible once again to the West. Extensive sums of money were allocated by the neighbouring countries and exceptional building conservation ventures were launched, out of which some were included in Study 1. Out of the four factors studied; object value, team, finance and legislation I have since in the succeeding studies focused deliberately and exclusively on finance.

The outcome of Study 1 was achievable by the use of a strict investigation structure, of coded data from interviews referring to the individual factors, which reduced the observers; my own, influence on the study, all of which improved objectivity. The factors' reciprocal interactions, individual impact and significance were finally interpreted in the processes and the following tendencies could be revealed in the year 2000:

- High object value made the conservation process more uniform than a low.
- Legislation through result showed that the use of modern material was most frequent among high listed buildings, which is why the effect of protection was contrary to its intention.
- The Team factor was less evident, but two templates developed and tested, revealed correspondence between the Danish conservations and *completed projects* and Lithuanian conservations with *uncompleted projects*.
- Three distinct funding structures were found, yet only two reflected in the processes; private and public.

In the follow-up analysis of the initial findings in 2008, presented fully in this appendix, the focus was set on *finance* alone and how the two funding sources; private and public, influenced the conservation

processes. This was possible by observing changes in the other factors; object value, team and legislation, which is outlined in the graphical table, (GC1). The study showed a difference in the funding flow, where private funding seemed to be more stable and limited in time than public funding. The drawbacks of instable funding flow are that the conservation measures become prolonged, which in turn may cause new damages, and thus may increase the costs. The discrepancy in project length cannot be explained by the differences of building categories; the expensive manors, like churches are just as intricate and challenging to preserve. The long-lasting publicly funded conservations must have other grounds, such as what the buildings signify for society; political or religious signs of power.

The two financiers' process influence outlined in the graphical table revealed:

- *Private funding; Financial flow; more stable and brief*
- *Public funding; Financial flow; instable and prolonged*

The strict selection of the two financiers of funding according to object value, which was also clear, limited the public objectives for heritage support. This tendency could not be established in the privately funded. To favour one specific building category can be said to signify an obsolete and early 20th century approach, which might distance heritage funding actions from today's society. The two financiers' process influence outlined in the graphical table revealed:

- *Private funding; No limitations in funding objectives*
- *Public funding; Limitations in funding objectives; manors*

The funding sources brought about individual approaches within the projects' team and the privately funded exposed a more pragmatic approach for solving the buildings' future use or to ensure revenues from investment. The team in publicly funded building conservations, on the other hand, aimed at conserving or reconstructing the legacy. The publicly funded ventures can consequently not sustain the heritage intact construction wise, since they reduce its income potential as well which ensures its future up-keep.

The two financiers' process influence outlined in the graphical table revealed:

- *Private funding; team aims of building conservation; do the job, pragmatic approach*
- *Public funding; team aims of building conservation; to conserve the building (status quo)*

Additional findings revealed that both modern and traditional building materials were applied in public projects for reconstruction works. This actually opposes the initial intention of listing and brings a double standard, especially since only the traditional materials originally used, have proved to be long-lasting and more applied in the privately funded projects.

The two financiers' process influence outlined in the graphical table revealed:

- *Private funding; Result tendencies; measures traditional building material*
- *Public funding; Result tendencies; measures modern and traditional material*

The fact that public funding used to dominate in former Eastern Europe, and that it was inadequate, explains why the conservation

projects from Lithuanian and Poland were corresponding to the *un-complete* template-pattern. However, the fact that Denmark was in dominance for private funding and matched the *completed project* template, need to be studied further.

- *Private funding; Finance form significant for; Denmark*

- *Public funding; Finance form significant for; Poland and Lithuania*

3.2 Study 2; 2000-2004 and conclusion

The comparative study of the financial structures in twelve restoration projects from six countries; Denmark, Germany, Great Britain, Norway, Finland and Sweden, aimed at investigating whether building conservations financed by one source; public funding – may reduce actor’s involvement, just as building category objectives do and what to preserve, as well. An ideal cast list was developed for the study to be applied as a comparative index showing how *donor, driver, recipient, distributor* and *controller* were distributed differently among the participants in the projects.

The study revealed first of all that by limiting the finance source to public funding, the variety of actors involved was indeed reduced, as well as the category of built heritage which was chosen. Moreover, four out of five *roles* in private funded projects were cast by different private groups. This opposed the publicly funded ones where four out of five roles could be the same heritage authority. This limiting effect of the public heritage funding might imply a less democratic process, but also exclude local communities from being involved in heritage issues, which is essential in order to view that heritage is an asset. The private funding is a collaborative one that can engage inhabitants from all age groups. This explains its limitless funding objectives. Promoting private initiatives for advocating the local built cultural heritage might even limit the initial costs as well, since this is based on a voluntary commitment

The table 32.1 finally sums up all findings from Study 1 and 2 for clarifying the different influence or impact which private and public financiers had, thus combining the tendencies observed in the conservation project processes and the actor groups.

Projects privately funded (G1)

Significance of actor groups

A democratic actors group
 An initiated and energetic donor
 Driver committed person locally linked
 An active Recipient
 An extern distributor
 A double controller

Significance of processes

All historic buildings
 No political influence
 Low initial costs no paid driver
 Object value growing

Projects publicly funded (G2)

Significance of actor groups

A two way discussion
 A correct and just donor
 Driver anonymous state
 A passive Recipient
 An intern distributor
 A single controller

Significance of processes

Selected buildings
 Program buildings
 High initial costs
 Object value status quo

Table 32.1 The observed impact of private and public financiers on the building conservation processes and the actor groups studied.

The outcome of the studies revealed the significant effects discerned in the conservation project funded by public or private means, with respect to actor's involvement as follows;

Built cultural heritage finance by private sources revealed that;

- More donors brought a higher number of actors involved
- State representative was involved, no matter what funding form
- The driver, project initiator was owner or recipient
- The donor incentives for funding also affect the outcome/decisions
- No limitations in funding objectives; all building categories included.

Built cultural heritage finance by public sources revealed that;

- One financier engaged less actors and the dialogue was limited to recipient and state
- The driver, project initiator and the donor are one and the same
- The distributor of funds and controller of measures are identical actors
- Limitations in funding objectives; only industrial buildings or to projects within national policy programs.

The two hypotheses set up for Study 2; of limitations of actors involvement and restrictions of built heritage, could be verified. The outcomes showed that; limiting the financiers only to public funding, restricted the multitude of actor's participation in the building conservation projects studied. The singular public funding reduced as well the choice of building categories, this time to the early industrial and technical buildings and these corresponded to the choice of manors in Study 1. The cooperative private funding revealed no limitations funding objectives.

The fact that private heritage funding automatically includes many actors in building preservation processes, means their personal goals or value preferences in built legacy of the parties, will always be less obvious in the conservation processes, than if one financier is in dominance, as is the case with public funding. This is why the assertion by Carla Bodo can be confirmed "*The private sectors financial contribution guarantees pluralism which is a precondition of democracy*" The outcome of Study 1 and 2, describing heritage economics through the case studies in progress during 1990-2004, became the basis for the continuing study in 2008 to establish the heritage finance model.

Illustration of the findings from Study 1 and Study 2

1. More actors are involved in G1 than G2 and the *donor* makes the difference.

Private

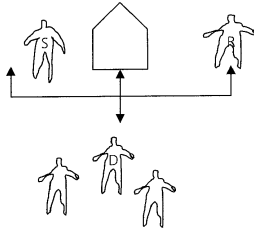

The donor is an important distinction that brings more processes. The donor often has a saying when it comes to adapting for new functions in the BCH with private money.

Public

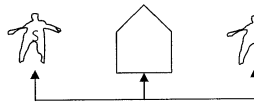

It is a two part discussion between recipient and authority/public body that is distributing public grants.

3. The *donor* is a foundation and private+ state in G1s and state is in dominance in G2s.

Private

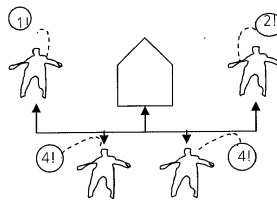

Two main sources are required for the private funded projects to succeed; private+state as well as foundations that can indicate a more democratic process with disputes and discussions

Public

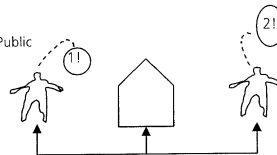

When only public means are distributed; a more uniform idea is behind the contribution.

4. The *driver* is the active receiver in G1 and in G2 is the driver the financier also.

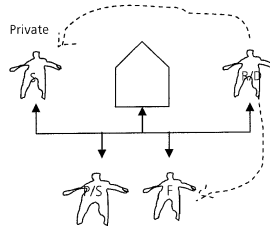

The driver is the private owner that is emotionally involved in order to get grants.

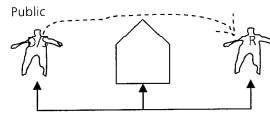

The engagement for public means is based on a decision made by authorities; the drivers are all employees assigned to the project at the public body.



5. The *recipient* is the private owner in G1 and in G2 no matter financial source.

6. The *distributor* in G1 are foundations and in G2 the authority in charge.

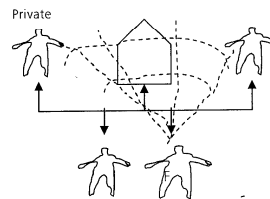

The main financier plays an active role in the projects such as foundations for private means and regional authority for public.

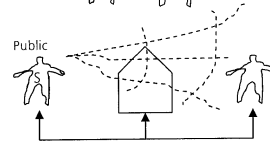

The central authority is still participating but might have a weaker position than the distributing regional authority Using funding or subsidy such as "control tool".

7. The controller in G1 is split on two parties; central authority and foundation.

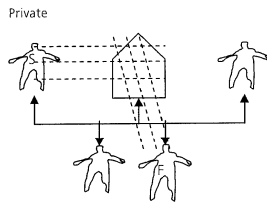

The highest authority is needed since the financier is an active private part.

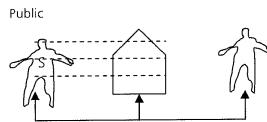

Only one controller active in G2. The regional authority handles the control and distribution on the local level in project subsidised by public means.

POSTEN	1. ANSÖKANDE	2. SAMRÅD	3. ANSÖKANDE	4. SVAR	5. MEDGÅVA	6. ANSÖKANDE	7. GODKÄNT	8. BEKÄNDRING	9. BEKÄNDRING	10. LÖSNING	11. SVT. PÅT. FÖRE	12. SVT. PÅT. EFTER	13. SVT. SLUT	14. SVT. SVARA	15. SVT. SVARA
A	ANSÖKANDE	ANSÖKANDE	ANSÖKANDE	ANSÖKANDE	ANSÖKANDE	ANSÖKANDE	ANSÖKANDE	ANSÖKANDE	ANSÖKANDE	ANSÖKANDE	ANSÖKANDE	ANSÖKANDE	ANSÖKANDE	ANSÖKANDE	ANSÖKANDE
B	ANSÖKANDE	ANSÖKANDE	ANSÖKANDE	ANSÖKANDE	ANSÖKANDE	ANSÖKANDE	ANSÖKANDE	ANSÖKANDE	ANSÖKANDE	ANSÖKANDE	ANSÖKANDE	ANSÖKANDE	ANSÖKANDE	ANSÖKANDE	ANSÖKANDE
C	ANSÖKANDE	ANSÖKANDE	ANSÖKANDE	ANSÖKANDE	ANSÖKANDE	ANSÖKANDE	ANSÖKANDE	ANSÖKANDE	ANSÖKANDE	ANSÖKANDE	ANSÖKANDE	ANSÖKANDE	ANSÖKANDE	ANSÖKANDE	ANSÖKANDE
D	ANSÖKANDE	ANSÖKANDE	ANSÖKANDE	ANSÖKANDE	ANSÖKANDE	ANSÖKANDE	ANSÖKANDE	ANSÖKANDE	ANSÖKANDE	ANSÖKANDE	ANSÖKANDE	ANSÖKANDE	ANSÖKANDE	ANSÖKANDE	ANSÖKANDE
E	ANSÖKANDE	ANSÖKANDE	ANSÖKANDE	ANSÖKANDE	ANSÖKANDE	ANSÖKANDE	ANSÖKANDE	ANSÖKANDE	ANSÖKANDE	ANSÖKANDE	ANSÖKANDE	ANSÖKANDE	ANSÖKANDE	ANSÖKANDE	ANSÖKANDE
F	ANSÖKANDE	ANSÖKANDE	ANSÖKANDE	ANSÖKANDE	ANSÖKANDE	ANSÖKANDE	ANSÖKANDE	ANSÖKANDE	ANSÖKANDE	ANSÖKANDE	ANSÖKANDE	ANSÖKANDE	ANSÖKANDE	ANSÖKANDE	ANSÖKANDE
G	ANSÖKANDE	ANSÖKANDE	ANSÖKANDE	ANSÖKANDE	ANSÖKANDE	ANSÖKANDE	ANSÖKANDE	ANSÖKANDE	ANSÖKANDE	ANSÖKANDE	ANSÖKANDE	ANSÖKANDE	ANSÖKANDE	ANSÖKANDE	ANSÖKANDE
H	ANSÖKANDE	ANSÖKANDE	ANSÖKANDE	ANSÖKANDE	ANSÖKANDE	ANSÖKANDE	ANSÖKANDE	ANSÖKANDE	ANSÖKANDE	ANSÖKANDE	ANSÖKANDE	ANSÖKANDE	ANSÖKANDE	ANSÖKANDE	ANSÖKANDE
I	ANSÖKANDE	ANSÖKANDE	ANSÖKANDE	ANSÖKANDE	ANSÖKANDE	ANSÖKANDE	ANSÖKANDE	ANSÖKANDE	ANSÖKANDE	ANSÖKANDE	ANSÖKANDE	ANSÖKANDE	ANSÖKANDE	ANSÖKANDE	ANSÖKANDE
J	ANSÖKANDE	ANSÖKANDE	ANSÖKANDE	ANSÖKANDE	ANSÖKANDE	ANSÖKANDE	ANSÖKANDE	ANSÖKANDE	ANSÖKANDE	ANSÖKANDE	ANSÖKANDE	ANSÖKANDE	ANSÖKANDE	ANSÖKANDE	ANSÖKANDE
K	ANSÖKANDE	ANSÖKANDE	ANSÖKANDE	ANSÖKANDE	ANSÖKANDE	ANSÖKANDE	ANSÖKANDE	ANSÖKANDE	ANSÖKANDE	ANSÖKANDE	ANSÖKANDE	ANSÖKANDE	ANSÖKANDE	ANSÖKANDE	ANSÖKANDE
L	ANSÖKANDE	ANSÖKANDE	ANSÖKANDE	ANSÖKANDE	ANSÖKANDE	ANSÖKANDE	ANSÖKANDE	ANSÖKANDE	ANSÖKANDE	ANSÖKANDE	ANSÖKANDE	ANSÖKANDE	ANSÖKANDE	ANSÖKANDE	ANSÖKANDE
LANSKYD	ANSÖKANDE	ANSÖKANDE	ANSÖKANDE	ANSÖKANDE	ANSÖKANDE	ANSÖKANDE	ANSÖKANDE	ANSÖKANDE	ANSÖKANDE	ANSÖKANDE	ANSÖKANDE	ANSÖKANDE	ANSÖKANDE	ANSÖKANDE	ANSÖKANDE
FINANSERING	ANSÖKANDE	ANSÖKANDE	ANSÖKANDE	ANSÖKANDE	ANSÖKANDE	ANSÖKANDE	ANSÖKANDE	ANSÖKANDE	ANSÖKANDE	ANSÖKANDE	ANSÖKANDE	ANSÖKANDE	ANSÖKANDE	ANSÖKANDE	ANSÖKANDE
RESURSER	ANSÖKANDE	ANSÖKANDE	ANSÖKANDE	ANSÖKANDE	ANSÖKANDE	ANSÖKANDE	ANSÖKANDE	ANSÖKANDE	ANSÖKANDE	ANSÖKANDE	ANSÖKANDE	ANSÖKANDE	ANSÖKANDE	ANSÖKANDE	ANSÖKANDE
TID	ANSÖKANDE	ANSÖKANDE	ANSÖKANDE	ANSÖKANDE	ANSÖKANDE	ANSÖKANDE	ANSÖKANDE	ANSÖKANDE	ANSÖKANDE	ANSÖKANDE	ANSÖKANDE	ANSÖKANDE	ANSÖKANDE	ANSÖKANDE	ANSÖKANDE

GC 1 The graphical outline of the structural pattern of the 15 conservation projects, based on the four factors; object value, team, legislation and finance of Study 1. The qualitatively coded data from the interviews; the answers signified by the majority opinion, in percentage points are in this chart statistically transformed into symbols in the clear graphical diagram, which then could be traced and analysed.

Appendix 2 International charters - cites on value and financial issues 27-8

(See 3.3.2.Overview of value concept progression in theory from 1600-2008)

1960-69

Venice Charter. International charter for the conservation and restoration of Monuments and sites.16 articles

(ARTICLE 5, The Venice Charter (2008,Web).

See chapter 3, Footnote 105.

... "The conservation of monuments is always facilitated by making use of them for some socially useful purpose. Such use is therefore desirable but it must not change the lay-out or decoration of the building. It is within these limits only that modifications demanded by a change of function should be envisaged and may be permitted, , The Venice Charter, (2008,Web).

1970-79

The International Symposium Budapest 1972

The International Symposium on the introduction of contemporary architecture into ancient groups of buildings, meeting in Budapest on 27th and 28th June.

(International Symposium Budapest (2008, Web).

See chapter 3, Footnote 109.

... "The authenticity of historical monuments.. ().. must be taken as a basic criterion and there must be avoidance of any imitations which would affect their artistic and historical value" "The revitalization of monuments.. ().. by the finding of new uses for them is legitimate and recommendable provided such uses affect, whether externally or internally, neither their structure nor their character as complete entities"...

The Resolutions of the International Symposium Rothenburg 1975

Resolutions of the International Symposium on the Conservation of Smaller Historic Towns in Rothenburg an der Tauber, 29-30th May

(International Symposium Rothenburg (Webb 2008)

See chapter 3, Footnote 111

... "Smaller historic towns can be classified into different types which are characterized by problems in common and by specific features which vary, among other things according to their size, cultural context and economic function"... "Such smaller towns are subject to specific dangers of various sorts: suffer from a lack of economic activity leading to the emigration...().. too much economic activity may cause disruption of the old structure...().. The tourism, which can be a legitimate means to economic revitalization, can also have a negative impact on the appearance"...

See chapter 3, Footnote 112.

... "To counteract the dangers threatening smaller historic towns...()... ensure their conservation by assigning them a role in keeping with their special structure: above all, the economic function of smaller towns should be selected so as to imply neither disruption nor dereliction of the historic substance"

"(iii) On the local level, too, planning must recognize the need to retain and to enhance the specific values of the town...().. the existing scale...().. visual qualities of urban spaces, streets and squares...().. search for appropriate new uses for empty buildings"...

European Charter of the Architectural Heritage 1975, October 1975

(European Charter of the Architectural Heritage (2008, Web)

See chapter 3, Footnote 114.

"the Council of Europe drafted the Charter which appears below. It is, of course, not sufficient simply to formulate principles; they must also be applied".

In future, the Council of Europe will devote its efforts to a thorough study of ways and means of applying the principles in each different country, the steady improvement of existing laws and regulations and the development of vocational training in this field"

"Considering that the future of the architectural heritage depends largely upon its integration into the context of people's lives and upon the weight given to it in regional

and town planning and development schemes...(.)... member states should take the necessary legislative, administrative, financial and educational steps to implement a policy of integrated conservation for the architectural heritage"... In the face of a rapidly changing civilization, in which brilliant successes are accompanied by grave perils, people today have an instinctive feeling for the value of this heritage...(.)...The architectural heritage is a capital of irreplaceable spiritual, cultural, social and economic value. (.).Each generation places a different interpretation on the past and derives new inspiration from it. This capital has been built up over the centuries...(.). Far from being a luxury this heritage is an economic asset which can be used to save community resources".

(www.icomos.org/docs/euroch_e.html)

(Funding)...“Where necessary the maintenance and restoration of the architectural heritage and individual parts therefore should be encouraged by suitable forms of financial aid and incentives, including tax measures. “It is essential that the financial resources made available by public authorities for the restoration of historic centres should be at least equal to those allocated for new construction”. “Conservation problems are not peculiar to any one country. They are common to the whole of Europe and should be dealt with in a coordinated manner”.

The Declaration of Amsterdam 1975

Congress of the European Architectural Heritage 21-25 October 1975.

(www.icomos.org/docs/amsterdam.html)

See chapter 3, Footnote 116.

...“Apart from its priceless cultural value, Europe’s architectural heritage gives to her peoples the consciousness of their common history and common future. Its preservation is, therefore, a matter of vital importance...(.). To help meet the cost of restoration, adaptation and maintenance of buildings and areas of architectural or historic interest, adequate financial assistance should be made available to local authorities and financial support and fiscal relief should likewise be made available to private owners...(.). Encouragement should be given to independent organizations - international, national and local - which help to awakened public interest”.

...“But it is also being realized that the conservation of ancient buildings helps to economise resources and combat waste, one of the major preoccupations of present-day society. It has been proved that historic buildings can be given new functions which correspond to the needs of contemporary life”

See chapter 3, footnote 118.

.....“Planners should recognize that not all areas are the same and that they should therefore be dealt with according to their individual characteristics. The recognition of the claims of the aesthetic and cultural values of the architectural heritage should lead to the adoption of specific aims and planning rules for old architectural complexes”

See chapter 3, footnote 119.

....“In particular it can induce new activities to establish themselves in economically declining areas in order to check depopulation and thereby prevent the deterioration of old buildings...(.)... development of peripheral urban areas can.. reduce pressure on the older neighbourhoods...(.). a better distribution of the focal points of urban activity may have an important impact on the conservation of the architectural heritage”.

See chapter 3 footnote 120...“The conservation of the architectural heritage, however, should not merely be a matter for experts. The support of public opinion is essential. The population...(.).should take a real part in every stage of the work, from the drawing up of inventories to the preparation of decisions”

.... “Proposals or alternatives put forward by groups or individuals should be considered as an important contribution to planning...(.). The conservation effort to be made must be measured not only against the cultural value of the buildings but also against their use-value”.

...“to enable the population to participate ..(.).they must be given the facts necessary to understand ..(.).the historic and architectural value of the buildings to be conserved”

... “To implement such a policy, which respects the man-made environment intelligently, sensitively and with economy, local authorities should...(.).afford functions to buildings which, whilst corresponding to the needs of contemporary life, respect their character and ensure their survival...(.)... devote an appropriate part of their budget to such a policy...(.).the creation of funds specifically earmarked ..(.).Local authority grants and loans made to private individuals...(.).associations..aimed at stimulating..involvement and financial commitment”

...“to increase the operational capacity of the authorities...(.). sufficient qualified personnel and essential scientific, technical and financial resources are put at their disposal”

...*Integrated conservation necessitates appropriate financial means...(.). It is difficult to define a financial policy applicable to all countries...(.). It is accordingly for every state to devise its own financing methods and instruments...(.). It can be established with*

certainly however, that there is scarcely any country in Europe where the financial means allocated to conservation are sufficient.
 "Methods must be devised to assess the extra cost occasioned by the constraints of conservation programmes.() .. sufficient funds should be available to help owners ..to..restoration work"
 ...“The financial advantages and tax concessions available for new building should be accorded in the same proportion for the upkeep and conservation of old buildings”.
 ...“Authorities should set up Revolving Funds.()..by providing local authorities or non-profit making associations with the necessary capital.()..to areas where such programmes can become self-financing.()..because of the rise in value accruing from the high demand for such attractive property.
 ...“It is vital. ()..to encourage all private sources of finance, particularly coming from industry. Numerous private initiatives have shown the viable part that they can play in association with the authorities at either national or local level.

1980-1989

Declaration of Tlaxcala 1982

"The Revitalization of Small Settlements", organized by the Mexican National Committee of ICOMOS and held in Trinidad, Tlaxcala, from 25 to 28 October 1982
 (<http://www.icomos.org/docs/tlaxcala.html>)
 See chapter 3 footnote 123

...“They further observe that the introduction of patterns of consumption and behaviour foreign to our traditions, which make their way in via the multiple communications media, assist the destruction of the cultural heritage by encouraging contempt for our own values, especially in the small settlements; they therefore urge governments, institutes of higher education and public or private bodies interested in the Preservation of the heritage to use the media at their disposal for the countering of the effects of this process.

..”It is recommended.()..That any initiative with a view to the conservation and revitalization of small settlements must be designed as a part of a programme embracing the historical, anthropological, social and economic aspects of the area and the possibilities for its revitalization, failing which it would be fated to be superficial and ineffectual..(Finance)

... “It is urgent that an effort be made to recognize and enhance the prestige and value inherent in the use of such materials and techniques where they exist, and to keep them alive with increasing forcefulness in the minds of the communities concerned. () .. That the governments of the Latin American countries consider as in the public interest the granting of funds for the acquisition, maintenance, conservation and restoration of dwellings in small settlements and the lesser towns, as a practical means of keeping alive the building heritage and the housing possibilities it affords. For this purpose there must be amendment of the norms governing the allocation of funds to enable buildings for which vernacular techniques and materials have been used to be eligible for mortgage loans.

The Declaration of Dresden 1982

ICOMOS National Committee of the German Democratic Republic, participants from 11 countries held a symposium in Dresden from November 15th to 19th, 1982 on the subject of the "Reconstruction of Monuments Destroyed by War",
 (<http://www.icomos.org/docs/dresden.html>)
 See chapter 3 footnote 125.

...“In reconstructing monuments destroyed by war various techniques have been developed. Multiplicities of factors have to be taken into account in each individual case. These range from the conservation of a monument for its symbolic value to the restoration of a townscape condition which cannot be abandoned...”

See chapter 3 footnote 126

.. “The need to continue the traditional use of a building has frequently accelerated the restoration of destroyed architectural monuments. Increasing awareness of the spiritual value of monuments has further encouraged this trend. This concerns to a large extent residential houses in towns and villages as well as town-halls, churches, and other historic buildings.().. The destruction of a monument frequently results in completely new objectives for social use and their understanding after its reconstruction being established. This may range from the efforts to find a use of great public significance to residential use.

Declaration of Rome 1983

The Italian National Committee, under the patronage of the Ministry of Cultural Property and of the Environment
(<http://www.icomos.org/docs/rome.html>)

While recalling the work accomplished at the national symposia of Sorrento (1979) and of Naples (1981), discussed the following theme in Rome (9-10 June 1983) on the basis of earlier studies: ...“Monuments and Sites: conservation action in Italy today”. “Given... ().. the lack of available economic and financial resources”.() “...serious deficiencies which exist in Italy today in the field of the conservation and the restoration of the cultural heritage. These deficiencies are due, on the one hand, to the insufficiently clear relationship between theory and practice, and on the other hand, to the inherent dangers of the current political and socio-economic situation.”.() “...serious deficiencies which exist in Italy today in the field of the conservation and the restoration of the cultural heritage. These deficiencies are due, on the one hand, to the insufficiently clear relationship between theory and practice, and on the other hand, to the inherent dangers of the current political and socio-economic situation.”..

See chapter 3 footnote 130

..“Serious consequences due to the fact that architectural restoration operations are too often awarded to insufficiently qualified professionals of the private and public sector..” ()..unqualified, private contractors on monuments, historic centres and sites. This phenomenon has been accentuated by the poor health of the construction industry which has led certain contractors toward restoration work despite their lack of training..” ()..requests of the Parliament... total involvement in the coordination.. careful programming of architectural operations and for the rigorous supervision of the real qualifications of professionals and contractors working in the field of restoration.

The Burra Charter 1988

Australia ICOMOS (www.marquis-lyle.com.au/bcsignificance.htm#2.0)
The Burra Charter has a version from 1999. Cultural Significance
(www.nsw.nationaltrust.org.au/burracharter..html#use)

...“Cultural significance” means aesthetic, historic, scientific, social or spiritual value for past, present or future generations (1.2). Compatible use means a use which respects the cultural significance of a place. Such a use involves no, or minimal, impact on cultural significance

Guidelines: cultural significance; ..“These guidelines are intended to clarify the nature of professional work done within the terms of the Burra Charter. They recommend a methodical procedure for assessing the cultural significance of a place, for preparing a statement of cultural significance and for making such information publicly available..”()..apply to any place likely to be of cultural significance regardless of its type or size..”() It cannot be assumed that any one practitioner will have the full range of skills required to assess cultural significance and prepare a statement.

...“Cultural significance is a concept which helps in estimating the value of places. The places that are likely to be of significance are those which help an understanding of the past or enrich the present, and which will be of value to future generations.

Although there are a variety of adjectives used in definitions of cultural significance in Australia, the adjectives “aesthetic”, “historic”, “scientific” and “social”, given alphabetically in the Burra Charter, can encompass all other values”.

(Aesthetic value)..“Aesthetic value includes aspects of sensory perception for which criteria can and should be stated. Such criteria may include consideration of the form, scale, colour, texture and material of the fabric; the smells and sounds associated with the place and its use”..

(Historic value)..“Historic value encompasses the history of aesthetics, science and society, and therefore to a large extent underlies all of the terms set out in this section.

A place may have historic value because it has influenced, or has been influenced by, an historic figure, event, phase or activity. It may also have historic value as the site of an important event. For any given place the significance will be greater where evidence of the association or event survives in situ, or where the settings are substantially intact, than where it has been changed or evidence does not survive. However, some events or associations may be so important that the place retains significance regardless of subsequent treatment.

(Scientific value)..“The scientific or research value of a place will depend upon the importance of the data involved, on its rarity, quality or representativeness, and on the degree to which the place may contribute further substantial information”..

(Social value)..“Social value embraces the qualities for which a place has become a focus of spiritual, political, national or other cultural sentiment to a majority or minority group”..

1990-1999

ICOMOS NEW ZEALAND 1992

Charter for the Conservation of Places of Cultural Heritage Value
(http://www.icomos.org/docs/nz_92charter.html)

Accordingly this charter has been adopted by the New Zealand National Committee of the International Council on Monuments and Sites at its Annual General Meeting on 4 October 1992. .."New Zealand retains a unique assemblage of places of cultural heritage value relating to its indigenous and its more recent peoples. These areas, landscapes and features, buildings, structures and gardens, archaeological and traditional sites, and sacred places and monuments are treasures of distinctive value".
"Conservation projects should include the following (i) definition of the cultural heritage value of the place, which requires prior researching of any documentary and oral history, a detailed examination of the place, and the recording of its physical condition"
... "20. Adaptation. The conservation of a place of cultural heritage value is usually facilitated by it serving a socially, culturally or economically useful purpose.
... "22. DEFINITIONS For the purposes of this charter: adaptation means modifying a place to suit it to a compatible use, involving the least possible loss of cultural heritage value... (.).. cultural heritage value means possessing historical, archaeological, architectural, technological, aesthetic, scientific, spiritual, social, traditional or other special cultural significance, associated with human activity".

The Nara Document 1994

Authenticity Heritage Convention held at Nara, Japan, from 1-6 November 1994,
(http://www.international.icomos.org/naradoc_eng.htm#va)

... "9. Conservation of cultural heritage in all its forms and historical periods is rooted in the values attributed to the heritage. Our ability to understand these values depends, in part, on the degree to which information sources about these values may be understood as credible or truthful. Knowledge and understanding of these sources of information, in relation to original and subsequent characteristics of the cultural heritage, and their meaning, is a requisite basis for assessing all aspects of authenticity".
... "11. All judgements about values attributed to cultural properties as well as the credibility of related information sources may differ from culture to culture, and even within the same culture. It is thus not possible to base judgements of values and authenticity within fixed criteria. On the contrary, the respect due to all cultures requires that heritage properties must be considered and judged within the cultural contexts to which they belong.
... "12. Therefore, it is of the highest importance and urgency that, within each culture, recognition be accorded to the specific nature of its heritage values and the credibility and truthfulness of related information sources.
... "13. Depending on the nature of the cultural heritage, its cultural context, and its evolution through time, authenticity judgements may be linked to the worth of a great variety of sources of information. Aspects of the sources may include form and design, materials and substance, use and function, traditions and techniques, location and setting, and spirit and feeling, and other internal and external factors. The use of these sources permits elaboration of the specific artistic, historic, social, and scientific dimensions of the cultural heritage being examined.
... "3. Particularly important are efforts to ensure that attributed values are respected, and that their determination included efforts to build, as far as possible, a multidisciplinary and community consensus concerning these values."

The Declaration of San Antonio 1996

ICOMOS National Committees of the Americas, met in San Antonio, Texas, United States of America, from the 27th to the 30th of March, 1996.
(http://www.icomos.org/docs/san_antonio.html)

... "have studied, read and discussed the documents produced in 1994 by the meetings of specialists on authenticity in Bergen, Norway, and Nara, Japan.. (.)..discussed the nature, definition, proofs, and management of authenticity in relation to the architectural, urban, archaeological and cultural landscape heritage of the.. (.)..issue the following summary of our findings and recommendations: The authenticity of our cultural heritage is directly related to our cultural identity.. (.)..The authenticity of our cultural resources lies in the identification, evaluation and interpretation of their true values as perceived by our ancestors in the past and by ourselves now as an evolving and diverse community".
... "AUTHENTICITY AND HISTORY. An understanding of the history and significance of a site over time are crucial elements in the identification of its authenticity.. (.).. The history of a site should not be manipulated to enhance the dominant values of certain groups over those of others"

...”AUTHENTICITY AND MATERIALS

The material fabric of a cultural site can be a principal component of its authenticity..()..the material elements ..are bearers of important information about our past and our identity..().. interaction between the resource and new and diverse cultural circumstances”.

...”AUTHENTICITY AND SOCIAL VALUE ..().. heritage sites can carry a deep spiritual message that sustains communal life, linking it to the ancestral past”

...”AUTHENTICITY IN DYNAMIC AND STATIC SITES. The heritage of the Americas includes dynamic cultural sites that continue to be actively used by society, as well as static sites such as archaeological sites no longer used by the descendants of their builders..().. This constant adaptation to human need can actively contribute to maintaining the continuum among the past, present and future life”

...”AUTHENTICITY AND STEWARDSHIP. The heritage of the Americas is characterized by very heterogeneous patterns of ownership and stewardship..().. This situation urgently demands that the proper national and local authorities and the present owners, stewards and inhabitants be made fully aware of the value that other majority and minority sectors of the population may have for the site.

...”AUTHENTICITY AND ECONOMICS. The authenticity of heritage sites lies intrinsically in their physical fabric, and extrinsically on the values assigned to them by those communities who have a stake in them..().. Since cultural tourism is often a substantial source of revenue for local and national economies, its development is acceptable..().. archaeological sites has been compromised through reconstructions..().. aimed to promote tourism reduce the authenticity of such sites..().. by altering the appearance of the site”.

“ICOMOS National Committees of the Americas hereby offer for discussion..().. we recognize.. ()..Nara Document as a valuable instrument..()..but find it incomplete ..().. based on the needs we have identified relating to the heritage of the Americas..().. That further consideration be given to the proofs of authenticity so that indicators may be identified for such a determination in a way that all significant values in the site may be set forth. The following are some examples of indicators: Reflection of the true value.. Integrity.. Context... Identity and Use and function. That is, the traditional patterns of use that have characterized the site”

The Stockholm declaration 1998

Declaration of ICOMOS marking the 50th anniversary of the Universal Declaration of Human Rights september 1998

(http://www.international.icomos.org/charters/stocdec_e.htm)

..”meeting in Stockholm, ICOMOS wishes to underline the importance of the Universal Declaration of Human Rights, celebrating its 50th anniversary in 1998, in particular its recognition of the right of everyone to partake freely in the cultural life of the community..()”This right carries duties and responsibilities for individuals and communities as well as for institutions and states. To protect this right today is to preserve the rights of future generations..().. The right to participate in decisions affecting heritage and the cultural values it embodies”. “They assume appropriate development strategies and an equitable partnership between society, the private sector and individuals to harmonize interests affecting cultural heritage, and to reconcile preservation with development”.

International cultural tourism charter, Mexico 1999

International cultural tourism charter; Managing Tourism at Places of Heritage Significance, Mexico 1999,

(www.international.icomos.org/charters/tourism_e.htm).

...“At the broadest level, the natural and cultural heritage belongs to all people. We each have a right and responsibility to understand, appreciate and conserve its universal values..()..The particular heritage and collective memory of each locality or community is irreplaceable and an important foundation for development, both now and into the future.

Principle 1-6 (1. cultural exchange..().. conservation should provide.. visitors opportunities.. to experience.. heritage and culture (“Since domestic and international tourism is among the foremost vehicles for cultural exchange, conservation should provide responsible and well managed opportunities for members of the host community and visitors to experience and understand that community’s heritage and culture at first hand”).

(2 Value conflicts “The relationship between Heritage Places and Tourism is dynamic and may involve conflicting values. It should be managed in a sustainable way for present and future generations”). 3 Conservations have to be satisfying for Tourism (Conservation and Tourism Planning for Heritage Places should ensure that the Visitor Experience will be worthwhile, satisfying and enjoyable”). 4 Tourism shall involve indigenous inhabitants (Host communities and indigenous peoples should be involved

in planning for conservation and tourism). 5 Tourism shall generate income locally (Tourism and conservation activities should benefit the host community). Principle 6; All heritage shall be protected no matter promotion for tourism. (Tourism promotion programmes should protect and enhance Natural and Cultural Heritage characteristics).

2000-2005

Victoria Falls, Zimbabwe 2003

ICOMOS Charter Principles for the analysis, conservation and structural restoration of architectural heritage 2003
(http://www.international.icomos.org/charters/structures_e.htm)

...“These Recommendations are intended to be useful to all those involved in conservation and restoration problems, but cannot in anyway replace specific knowledge acquired from cultural and scientific texts.

“ Value and authenticity of architectural heritage cannot be based on fixed criteria because the respect due to all cultures also requires that its physical heritage be considered within the cultural context to which it belongs.

“The value of architectural heritage is not only in its appearance, but also in the integrity of all its components as a unique product of the specific building technology of its time. In particular the removal of the inner structures maintaining only the façades does not fit the conservation criteria”.

“When any change of use or function is proposed, all the conservation requirements and safety conditions have to be carefully taken into account”.

“ Each intervention should, as far as possible, respect the concept, techniques and historical value of the original or earlier states of the structure and leaves evidence that can be recognised in the future”.

Xi’an declaration 2005

The Revitalization of Small Settlements from 25 to 28 October 1982
(Declaration of Tlaxcala (2008, Web).

...“Acknowledge the contribution of setting to the significance of heritage monuments, sights and areas” is the value issue discussed and defined as “Heritage structures.()...derive their significance and distinctive character from their perceived social and spiritual, historic, artistic, aesthetic, natural, scientific or other cultural values...() also from their meaningful relationship with their physical...()..context and settings”

...“ Economical resources should be allocated to research, assessment and strategic planning of the conservation and management of setting of heritage structures, sights and areas”

Council of Europe Framework Convention on the Value of Cultural Heritage for Society Faro, 27.X.2005

(<http://conventions.coe.int/Treaty/EN/Treaties/Html/199.htm>)

...“Considering that one of the aims of the Council of Europe is to achieve greater unity between its members for the purpose of safeguarding and fostering the ideals and principles, founded upon respect for human rights, democracy and the rule of law, which are their common heritage;

Recognising the need to put people and human values at the centre of an enlarged and cross-disciplinary concept of cultural heritage;

Emphasising the value and potential of cultural heritage wisely used as a resource for sustainable development and quality of life in a constantly evolving society;

“...Convinced of the soundness of the principle of heritage policies and educational initiatives which treat all cultural heritages equitably and so promote dialogue among cultures and religions;

...”Article 1 – Aims of the Convention..

c emphasise that the conservation of cultural heritage and its sustainable use have human development and quality of life as their goal;

d take the necessary steps to apply the provisions of this Convention concerning:

– the role of cultural heritage in the construction of a peaceful and democratic society, and in the processes of sustainable development and the promotion of cultural diversity;

– greater synergy of competencies among all the public, institutional and private actors concerned”..

..”Article 2 – Definitions

For the purposes of this Convention,

a cultural heritage is a group of resources inherited from the past which people identify, independently of ownership, as a reflection and expression of their constantly

evolving values, beliefs, knowledge and traditions. It includes all aspects of the environment resulting from the interaction between people and places through time;
b a heritage community consists of people who value specific aspects of cultural heritage which they wish, within the framework of public action, to sustain and transmit to future generations”..

...”Article 3 – The common heritage of Europe

The Parties agree to promote an understanding of the common heritage of Europe, which consists of:

a all forms of cultural heritage in Europe which together constitute a shared source of remembrance, understanding, identity, cohesion and creativity, and
b the ideals, principles and values, derived from the experience gained through progress and past conflicts, which foster the development of a peaceful and stable society, founded on respect for human rights, democracy and the rule of law.

...”Article 4 – Rights and responsibilities relating to cultural heritage

The Parties recognise that:

a everyone, alone or collectively, has the right to benefit from the cultural heritage and to contribute towards its enrichment;

...”Article 5 – Cultural heritage law and policies

The Parties undertake to:

a recognise the public interest associated with elements of the cultural heritage in accordance with their importance to society;

b enhance the value of the cultural heritage through its identification, study, interpretation, protection, conservation and presentation;

c ensure, in the specific context of each Party, that legislative provisions exist for exercising the right to cultural heritage as defined in Article 4;

d foster an economic and social climate which supports participation in cultural heritage activities;

e promote cultural heritage protection as a central factor in the mutually supporting objectives of sustainable development, cultural diversity and contemporary creativity;

f recognise the value of cultural heritage situated on territories under their jurisdiction, regardless of its origin;“

...”Section II – Contribution of cultural heritage to society and human development

Article 7 – Cultural heritage and dialogue

The Parties undertake, through the public authorities and other competent bodies, to:

a encourage reflection on the ethics and methods of presentation of the cultural heritage, as well as respect for diversity of interpretations;

b establish processes for conciliation to deal equitably with situations where contradictory values are placed on the same cultural heritage by different communities;”..

...”Article 8 – Environment, heritage and quality of life

The Parties undertake to utilise all heritage aspects of the cultural environment to:

a enrich the processes of economic, political, social and cultural development and land-use planning, resorting to cultural heritage impact assessments and adopting mitigation strategies where necessary;”..

...”Article 9 – Sustainable use of the cultural heritage

To sustain the cultural heritage, the Parties undertake to:

a promote respect for the integrity of the cultural heritage by ensuring that decisions about change include an understanding of the cultural values involved;

b define and promote principles for sustainable management, and to encourage maintenance;

d promote the use of materials, techniques and skills based on tradition, and explore their potential for contemporary applications;”..

...”Article 10 – Cultural heritage and economic activity

In order to make full use of the potential of the cultural heritage as a factor in sustainable economic development, the Parties undertake to:

a raise awareness and utilise the economic potential of the cultural heritage;”..

...”Section III – Shared responsibility for cultural heritage and public participation

Article 11 – The organisation of public responsibilities for cultural heritage

In the management of the cultural heritage, the Parties undertake to:

a promote an integrated and well-informed approach by public authorities in all sectors and at all levels;

b develop the legal, financial and professional frameworks which make possible joint action by public authorities, experts, owners, investors, businesses, non-governmental organisations and civil society;”..

...”Article 12 – Access to cultural heritage and democratic participation

The Parties undertake to:

a encourage everyone to participate in:

– the process of identification, study, interpretation, protection, conservation and presentation of the cultural heritage ;

- public reflection and debate on the opportunities and challenges which the cultural heritage represents;
- b take into consideration the value attached by each heritage community to the cultural heritage with which it identifies;
- c recognise the role of voluntary organisations both as partners in activities and as constructive critics of cultural heritage policies;
- d take steps to improve access to the heritage, especially among young people and the disadvantaged, in order to raise awareness about its value, the need to maintain and preserve it, and the benefits which may be derived from it”..

...”Article 13 – Cultural heritage and knowledge

The Parties undertake to:

- a facilitate the inclusion of the cultural heritage dimension at all levels of education, not necessarily as a subject of study in its own right, but as a fertile source for studies in other subjects;
- b strengthen the link between cultural heritage education and vocational training;
- c encourage interdisciplinary research on cultural heritage, heritage communities, the environment and their inter-relationship;”..

...”Article 14 – Cultural heritage and the information society

The Parties undertake to develop the use of digital technology to enhance access to cultural heritage and the benefits which derive from it, by:

- d recognising that the creation of digital contents related to the heritage should not prejudice the conservation of the existing heritage”...

...”Section IV – Monitoring and co-operation

Article 15 – Undertakings of the Parties

The Parties undertake to:

- a develop, through the Council of Europe, a monitoring function covering legislations, policies and practices concerning cultural heritage, consistent with the principles established by this Convention;
- b maintain, develop and contribute data to a shared information system, accessible to the public, which facilitates assessment of how each Party fulfils its commitments under this Convention”..

...”Article 16 – Monitoring mechanism

a The Committee of Ministers, pursuant to Article 17 of the Statute of the Council of Europe, shall nominate an appropriate committee or specify an existing committee to monitor the application of the Convention, which will be authorised to make rules for the conduct of its business;”..

2006-2008

Declaration of Foz do Iguaçu 2008

(www.international.icomos.org/centre_documentation/declaration-iguacu-eng.pdf.)

ICOMOS in May 2008 met to reflect on the meaning of “spirit of place” interpreted at the meeting as an interaction between the material (building) and the intangible nature or manmade settings. To identify and understand what defines the spirit of place is vital if to keep the identity in a community or region, sustainable while handed over /transmitted from one generation to the other. ...”The value system and the social practices of communities be understood and respected as part of the “spirit of the place”.

Quebec declaration on the preservation of the spirit of place 2008

(www.international.icomos.org/home.htm)

...”The declaration of principles and recommendations to preserve the spirit of the place through safeguarding of tangible (Such as buildings, sites, routes) and intangible heritage (memories, written documents and rituals)...(.). efficient manner of ensuring sustainable and social development throughout the world”. The two value categories create a hole and interact. The approach is considered more adaptable to the globalized society which means interaction between cultures. Although strategic plans are needed to secure the spirit of places they are undergoing constant changes depending on the vitality of memory and will vary over time. Cities like Jerusalem have several “spirits” since interpreted by many religious groups. Digital communication tool are suggested to be used efficiently for low cost inventories which are necessary since “communication is the best tool for keeping the spirit of place alive”..

Appendix 3

3.5 Tests of value concept in practice

Unnerbäck and H₃UNS

Table of content

1. The value assessment system of;
 - 1.1 Unnerbäck
 - 1.2 HUNS
 - 1.3 Unnerbäck and H₃UNS/H₃NBS (Swedish)

2. Reflections of value assessment systems;
 - 2.1 Unnerbäck and H₃UNS
 - 2.2 Unnerbäck and H₃UNS/H₃NBS (Swedish)

3. Results from study;
 - 3.1 Expert group, Master students attending the CMHB course
 - 3.2 Student of architecture 4th year at the Department of building conservation
 - 3.3 Mixed group of laymen

1. The value assessment system of;

1.1 Unnerbäck (test of experts and students)

Axel Unnerbäck Value definitions, National board of antiquities RAÄ

Assessment system two main categories; document value and experience value

Document value (quantitative scale)

What history, and story, you can interpret from the building itself;

Building historic value, building technique value, patina, architectural value, society historical value, social historic value, Personal historic value, technique historical value,

Experience value (qualitative scale)

What other “intangible” values can you recognise in a building, more difficult to describe;

Architectural value, art value, patina, environmental value, identity value, continuity value, tradition value, symbol value

Brief value description

Document value:

building historic value

what age?, how old?, rareness brings high value definition, authenticity = high value

building technique value

ancient techniques, vault constructions or other no longer practiced, what age?, how old?, rareness brings high value definition, authenticity = high value

patina

traces of human activity, traces of use, wear (and tear), patina is lost when an old building is “repaired” to new construction standard in all sense

architecture historical value

what age?, how old?, one of its kind, ancient, milestone for other buildings (role model)

society historical value

telling a story about the society, large impact on the local or regional society such as court house, fire station, community hall

social historic value

linked to society v. but for environment closer and affecting to human lives (working class dwellings, poverty houses..)

personal historic value

linked to a former resident that was significant in its time (or still is) an author, politician, hero..

technique historical value

industrial production, mines, factories...

Experience value:

architectural value

while representing its own architecture style but, -well proportioned, representative, rare, complete context...

art value

The architecture with the "extra" fine craftsmanship (stucco ceiling), interior settings unique, fresco paintings..

patina

The "spirit" of ancient times, the feeling still intact?

environmental value

Importance for a context, built environments completeness

identity value

the ability to stimulate to a safe, sense of belonging to its environment, the importance for keep "good feeling"

continuity value

the ability to tell the story of a development in a society, more holistic approach

tradition value

the capacity to keep a tradition alive, an old bus stop or dance palace

symbol value

a sign/symbol for a nation, a town or a region, historical event

1.2 H₃UNS (test of experts and students)

H₃UNS Value assessment system

Value category	Definition (explanations for guidance)
H₁ Historical quality value	<i>culture, spiritual, social, relationship, contextual, historical, documental, anthropological, tradition, familiarity, age,</i>
H₂ Historical knowledge value	<i>artistic, scientific, concept, form, identity, architectural, knowledge, event</i>
H₃ Historical quantity value	<i>construction, authenticity, original, quality of work, reversibility, condition/state, decoration original</i>
U Utility value	<i>adaptability for use, tourism, pedagogical,</i>
N Nominal value	<i>economical resource, e-asset, e- investment, e -aspect</i>
S Symbol value	<i>national greatness, landmark</i>

Value identifications with the H₃UNS assessment system

Evaluation of _____
(building/location)

Value category	Notes (own words)
H₁ Historical quality value	
H₂ Historical knowledge value	
H₃ Historical quantity value	

U Utility value		
N Nominal value		
S Symbol value		
Additional comments (sketches and texts)		

1.3 Unnerbäck and HUNS (Test of aymen)

Analys av kulturhistorisk värde efter Unnerbäck's modell

Huvudgrupper för analys:

- Dokumentvärde
- Upplevelsevärde

1. Dokumentvärde undergrupper för analys avser:

Traditionella kriterier baserad på historisk kunskap, vad man brukar kalla objektiva (alt. Kvantitativa).

2. Upplevelsevärde undergrupper för analys avser:

Estetiska , upplevelsemässiga och socialt engagerande. Gränsen mellan värdekategorier kan vara flytande eller vad man kan kalla subjektiva (alt. Kvalitativa)

Värdekategorier eller checklista för dokumentvärde

- byggnadshistoriskt värde (*ålder eller ålderdomlighet*)
- byggnadsteknikhistoriskt värde (*äldre byggnadsteknik ss valvslagning*)
- patina (*spår av gångna tider, människors bruk, nötning, oxidation=estetik, objektivt*)
- arkitekturhistoriskt värde (*arkitektskapelse, mönsterbildade, betydelse*)
- samhällshistoriskt värde (*förtydligar samhällets historia, nation/region/lokalt*)
- socialhistoriskt värde (*förtydligar människans historia i samhället, se ovan*)
- personhistoriskt värde (*relaterar till välkänd person*)
- teknikhistoriskt värde (*industrins byggnader/för produktion*)

Värdekategorier eller checklista för upplevelsevärde

(stryk under det du tycker finns)

- arkitektoniskt värde (*arkitektoniska kvalitet, form, proportioner*)
- konstnärligt värde (*främst i interiör som utsmyckningar, dekorationer*)
- patina (*spår av gångna tider, människors bruk, nötning, oxidation=estetik, subjektivt*)
- miljöskapade värde (*förskönar, förstärker eller karaktäriserar platsen den står*)
- identitetsvärde (*bidrar till trygghet, igenkännande mm för människor*)
- kontinuitetsvärde (*visar framväxten, utvecklingen i ett levande samhälle*)
- traditionsvärde (*förknippade med traditioner, händelser eller tilldragelser*)
- symbolvärde (*symbol för en ort, en nation, ideologier, makt mm*)
-

Analys av kulturhistorisk värde efter H₃NBS modell (HUNS)

Analysgrupper:

Historiskt värde

Nominellt värde

Bruksvärde

Symbolvärde

- Värde-kategorin Historiskt värde avser

-

Egenskaper som ger en känsla av historia eller av gångna tider (Ja / nej)

Historiska spår som blir tydligare för konsthistoriker specialiserade stilhistoria (Ja/nej)

Synliga och kvalitativa spår av historia eller av gångna tider (Ja / nej)

- Värde-kategorin Nominellt värde avser:

Är högt värderad i "reda pengar", en ekonomisk resurs, en tillgång (Ja / nej)

- Värde-kategorin Bruksvärde avser:

Förmågan att anpassas för nya funktioner, turistattraktion, pedagogisk förånga (Ja/nej)

- Värde-kategorin Symbolvärde avser:

Ett landmärke för en bygd, känsla av trygghet, igenkännande "hemma" (Ja / nej)

- 2. Reflections of value assessment systems;
- 2.2 Reflections (experts and students)

Reflections on value assessment systems; Unnerbäck, HUNS, Exner
Write brief comments

- 1. Advantages to evaluate with the Unnerbäck value form?

- 2. Disadvantages evaluate with the Unnerbäck value form?

- 3. Advantages to evaluate with the HUNS value form?

- 4. Disadvantages evaluate with the HUNS value form?

- 5. Advantages to evaluate with the EXNER value form?

- 6. Disadvantages evaluate with the EXNER value form?

What professional groups prefer the different value systems?

(pick the relevant professional groups from the list under the value systems)

List: Proprietors/owners, architects, engineers, craftsmen (skilled), entrepreneurs, historians, people in general, investors/tycoons, builders, building workers, youth, senior citizens

UNNERBÄCK	HUNS	EXNER

2.2 Reflections (laymen)

Utvärdering av kulturvärdesanalys av Rådhuset i Skanör

(vv svara kortfattat eller endast i form av stödord)

1. Vilka är fördelarna med Unnerbäcks värderingsmodell?
2. Vilka är nackdelarna med Unnerbäcks värderingsmodell?
3. Vilka är fördelarna med H₃NBS värderingsmodell?
4. Vilka är nackdelarna med H₃NBSs värderingsmodell?
5. Vilka yrkesgrupper i byggsektor föredrar (värdera, förstå, använder) Unnerbäck-modell?
(stryk under de olika du väljer som svar)

Husägare	arkitekt	ingenjör	hantverkare
Entrepreörer/företagare	historiker	alla människor	
investerare/finansiär		byggentreprenör(byggare)	
byggnadsarbetare		ungdomar el. yngre	
äldre människor			

- Vilka yrkesgrupper i byggsektor föredrar (värdera, förstå, använder) H₃NBS -modell?
(stryk under de olika du väljer som svar)

Husägare	arkitekt	ingenjör	hantverkare
Entrepreörer/företagare	historiker	alla människor	
investerare/finansiär		byggentreprenör(byggare)	
byggnadsarbetare		ungdomar el. yngre	
äldre människor			

3. Results from study

3.1 Master students attending the CMHB course sponsored by SIDA

(+ additional groups)	Experts	Students	Laymen
Advantages Unnerbäck	I	II	III
Groups of comment categories:			
J= Judgement,	20/34= 58,8%	33%	86% =59,2%
P=practical tool,	10/34= 29,4%	55%	14%=24%
O= Objectivity,	3/34= 8,8%	11%	-

Disadvantages Unnerbäck	I	II	III
Groups of comment categories:			
L=Lacks/limitations	9/24= 37,5%	33%	44%= 38%
C= Complicated/confusing	6/24= 25%	11%	44%=27%
S=Subjective	3/24= 12,5%	11%	-
R=Repetitive	3/24= 12,5%	44,4%	-
MK= More knowledge demanding	3/24= 12,5%	-	11%

Actors groups preferring Unnerbäck

	I	II	III
1. Architects	23,2%	25%	21%=24%
2. Historians	18%	30%	21=23%
3. Craftsmen (skilled)	13%	15%	9,3%=12%
4. Engineers	7,4%	10%	9,3%=9%
5. Investors/tycoons	8,3%	-	-
Proprietors		10%	11,6%
Older people			11,6%

Coding analysis

Advantages H₃UNS

	I	II	III
Groups of comment categories:			
D= Direct/clear,	8/28= 28,5%	27%	10%=22%
MP= Management/planning future,	7/28= 25% ^o	9%	10%=15%
Q= Quick/easy,	6/28= 21,5%	27%	60%=36%
VI= Value improvements,	5/28= 17,9%	27%	20%=22%
S&O= Subjective/Objective,	2/28= 7%	9%	-

Disadvantages H₃UNS

	I	II	III
Groups of comment categories:			
L= Lacks/limitations,	20/25= 80%	75%	66%=73%
S= Subjective ,	3/25= 12%	-	-
MK= More knowledge demanding,	2/25= 8%	25%	22%=18%

Actors groups preferring H₃UNS

	I	II	III
1. Architects	14,5%	19%	
2. Historians	13,6%	-	
3. Craftsmen (skilled)	11,8	-	
4. Proprietors	9%	14,2	
5. Engineers	8,1%	-	9,6%
6. Entrepreneur		19%	16%=12,5
7 investors/tycoons		19%	19,3= 19,2
8 Builders		14,2%	16%=15,1
9. Building workers			12,9%

3.2 Student of architecture 4th year at the Department of building conservation

Advantages Unnerbäck

P=practical tool,	5/9= 55%
J= Judgement,	3/9=33%
O&S= Objectivity,	1/9= 11%

Disadvantages Unnerbäck

R=Repetitive,	4/9= 44, 4%
L=Lacks/limitations,	3/9= 33%
C= Complicated/confusing,	1/9= 11%
S=Subjective,	1/9= 11%
MK= More knowledge demanding	-

Actors groups preferring Unnerbäck

1. Historians	30%
2. Architects	25%
3. Craftsmen (skilled)	15%
4. Proprietors	10%
4. Engineers	10%

Advantages H₃UNS

Q= Quick/easy,	3/11= 27%
D= Direct/clear,	3/11= 27%
VI= Value improvements,	3/11 27%
MP= Management/planning future,	1/11= 9%
S&O= Subjective/Objective,	1/11= 9%

Disadvantages H₃UNS

L= Lacks/limitations,	¾, 75%
MK= More knowledge demanding	¼, 25%
S=Subjective	

Actors groups preferring H₃UNS:

1. Entrepreneurs	19%
1. Architects	19%
1. Investors/tycoons	19%
2. Builders	14,2%
2. Proprietors	14,2%

3.3 Mixed group of laymen

Advantages Unnerbäck

J= Judgement	6/7= 86%
P=practical tool	1/7= 14%
O= Objectivity -	

Actors groups preferring Unnerbäck

1. Architects	21%
1. Historians	21%
2. Proprietors	11,6%
2. Older people	11,6%
3. Craftsmen	9,3%
3. Engineers	9,3%

Disadvantages Unnerbäck

L=Lacks/limitations,	4/9= 44%
C= Complicated/confusing,	4/9= 44%
MK= More knowledge demanding	1/9= 11%
S=Subjective	
R=Repetitive	

Advantages H₃UNS

Q= Quick/easy,	6/10= 60%
VI= Value improvements,	2/10=20%
D= Direct/clear,	1/10 = 10%
MP= Management/planning future,	1/10= 10%
S&O= Subjective/Objective	

Disadvantages H₃UNS

L= Lacks/limitations,	6/9 = 66%
MK= More knowledge demanding,	2/9= 22%
S=Subjective -	

Actors groups preferring H₃UNS

1. Investors/tycoons	19,3%
2. Entrepreneurs	16%
2. Builders	16%
3. Building workers	12,9%
4. Engineers	9,6%

Appendix 4

Distinctions of national policy; public and private-public directions

5.2.2.1-2 Coding of the data relation unfolding political past

Politic-historic relation	Finland	Norway	Sweden	Denmark	Germany	Great Britain
Historical relations	2	2	1	1	3	1
War effected	1	1	2	1	1	1
Present politics	2	2	4	4	3	1
European cooperation	2	3	2	1	1	1

Table 5222.1 Effects of dissimilarities in the society structures caused by political past of the two major funding groups; public and public-private was obvious only concerning historical relation; Finland- Norway and European cooperation; EU membership specified the public-private. On the individual level only Swedish built heritage was unaffected by the recent world wars.

The *Historical relations* convey three groups;

1. Great Britain, Denmark and Sweden are the most ancient and stabile nations that could grow more influential over time at the expense of others.
2. Finland and Norway, the youngest nations, which gained independence in the 20th century.
3. Germany united in the 19th century as a federal state.

Outcome: A majority of the nations in the public group are young nations. Germany's historical development makes the nation differ from the other nations, however this fact has little implication today.

The *War affect* conveys two groups;

1. Finland, Norway Denmark, Great Britain and Germany were all affected which is why physical and emotional reconstruction phases began in the 1950's.
2. Sweden; was a neutral state unaffected by physical war damage.

Outcome: The result has impact on built cultural heritage issues since the war damaged heritage united many nations by ICOMOS during the 20th century

The *Present politics* conveys four groups;

1. Great Britain Labour party
2. Norway and Finland coalition of social democrats with liberals
3. Germany Christian democrats in coalition with social democrats
4. Denmark and Sweden coalition Liberal and right wing parties

Outcome: The political trends represent only a great verity of directions without distinguishing any particular nation from the others.

The *European cooperation* conveys three groups:

1. Germany, Great Britain and Denmark all had an early membership in EU.
2. Finland and Sweden latest EU membership of all.
3. Norway, partial membership.

Outcome: The European Union membership distinguishes three groups where private-public nations all had early membership in EU, while the public funding ones had either late membership, or none at all, such as Norway.

5.2.3.1-2 Coding of the data relation unfolding national distinctions of heritage authorities

Historic authority effects	Finland	Norway	Sweden	Denmark	Germany	Great Britain
Finance solidity	2	2	3	1	1	1
Funding claims others	2	2	2	1	1	1
Financial reforms	1	1	2	1	1	1

Table 5232.1 The possible effects of differences in work strategies among heritage authorities in the two funding groups only was discerned by the reimbursement demands of the public-private group. Once more however Sweden diverged in comparison to the other nations regarding finance solidity and reforms.

The *Finance solidity* conveys three groups:

1. Stable funding situation; Denmark, Germany and Great Britain
2. Improved funding situation; Finland and Norway
3. Unstable funding situation; Sweden

Outcome: DK/G/GB and Fi/N represent two individual groups, which indicate promising finance prospects for built heritage. Heritage finance in Sweden seems to be problematic.

The *Funding claims others* convey two groups:

1. Funding claims others; Denmark, Germany and Great Britain
2. No funding claims others; Finland, Norway and Sweden

Outcome: Dk, G and GB urge others to fund through percentage challenges or via public promotions. F, N and S have no funding requests on other.

The *Financial reforms* convey two groups:

1. Yes; Finland, Norway, Denmark, Germany and Great Britain
2. No: Sweden

Outcome: Only Sweden has failed to develop funding enhancing reforms and the church fund only allocates public funding.