



LUND UNIVERSITY

Dynamic parameter estimation of atomic layer deposition kinetics applied to in situ quartz crystal microbalance diagnostics

Holmqvist, Anders; Törndahl, Tobias; Magnusson, Fredrik; Zimmermann, Uwe; Stenström, Stig

Published in:
Chemical Engineering Science

DOI:
[10.1016/j.ces.2014.02.005](https://doi.org/10.1016/j.ces.2014.02.005)

2014

Document Version:
Peer reviewed version (aka post-print)

[Link to publication](#)

Citation for published version (APA):
Holmqvist, A., Törndahl, T., Magnusson, F., Zimmermann, U., & Stenström, S. (2014). Dynamic parameter estimation of atomic layer deposition kinetics applied to in situ quartz crystal microbalance diagnostics. *Chemical Engineering Science*, 111, 15-33. <https://doi.org/10.1016/j.ces.2014.02.005>

Total number of authors:
5

Creative Commons License:
Unspecified

General rights

Unless other specific re-use rights are stated the following general rights apply:
Copyright and moral rights for the publications made accessible in the public portal are retained by the authors and/or other copyright owners and it is a condition of accessing publications that users recognise and abide by the legal requirements associated with these rights.

- Users may download and print one copy of any publication from the public portal for the purpose of private study or research.
- You may not further distribute the material or use it for any profit-making activity or commercial gain
- You may freely distribute the URL identifying the publication in the public portal

Read more about Creative commons licenses: <https://creativecommons.org/licenses/>

Take down policy

If you believe that this document breaches copyright please contact us providing details, and we will remove access to the work immediately and investigate your claim.

LUND UNIVERSITY

PO Box 117
221 00 Lund
+46 46-222 00 00

Dynamic Parameter Estimation of Atomic Layer Deposition Kinetics Applied to *in situ* Quartz Crystal Microbalance Diagnostics

A. Holmqvist^{a,*}, T. Törndahl^b, F. Magnusson^c, U. Zimmermann^b, S. Stenström^a

^a*Department of Chemical Engineering, Lund University, P.O. Box 124, SE-221 00 Lund, Sweden*

^b*Ångström Solar Center, Solid State Electronics, Uppsala University, P.O. Box 534, SE-751 21 Uppsala, Sweden*

^c*Department of Automatic Control, Lund University, P.O. Box 118, SE-221 00 Lund, Sweden*

Abstract

This paper presents the elaboration of an experimentally validated model of a continuous cross-flow atomic layer deposition (ALD) reactor with temporally separated precursor pulsing encoded in the Modelica language. For the experimental validation of the model, *in situ* quartz crystal microbalance (QCM) diagnostics was used to yield submonolayer resolution of mass deposition resulting from thin film growth of ZnO from $\text{Zn}(\text{C}_2\text{H}_5)_2$ and H_2O precursors. The ZnO ALD reaction intrinsic kinetic mechanism that was developed accounted for the temporal evolution of the equilibrium fractional surface concentrations of precursor adducts and their transition states for each half-reaction. This mechanism was incorporated into a rigorous model of reactor transport, which comprises isothermal compressible equations for the conservation of mass, momentum and gas-phase species. The physically based model in this way relates the local partial pressures of precursors to the dynamic composition of the growth surface, and ultimately governs the accumulated mass trajectory

*Corresponding author. Tel.: +46 46 222 8301; fax: +46 46 222 4526

Email addresses: anders.holmqvist@chemeng.lth.se (A. Holmqvist), tobias.torndahl@angstrom.uu.se (T. Törndahl), fredrik.magnusson@control.lth.se (F. Magnusson), uwe.zimmermann@angstrom.uu.se (U. Zimmermann), stig.stenstrom@chemeng.lth.se (S. Stenström)

at the QCM sensor. Quantitative rate information can then be extracted by means of dynamic parameter estimation. The continuous operation of the reactor is described by limit-cycle dynamic solutions and numerically computed using Radau collocation schemes and solved using CasADi's interface to IPOPT. Model predictions of the transient mass gain per unit area of exposed surface QCM sensor, resolved at a single pulse sequence, were in good agreement with experimental data under a wide range of operating conditions. An important property of the limit-cycle solution procedure is that it enables the systematic approach to analyze the dynamic nature of the growth surface composition as a function of process operating parameters. Especially, the dependency of the film growth rate per limit-cycle on the half-cycle precursor exposure dose and the process temperature was thoroughly assessed and the difference between ALD in saturating and in non-saturating film growth conditions distinguished.

Keywords: Atomic layer deposition, Mathematical modeling, *in situ* film characterization, Experimental model validation, Parameter identification, Optimization

1. Introduction

Atomic layer deposition (ALD) is a gas-phase deposition process capable of producing conformal thin films with controlled uniform thickness in the nanometer range (George, 2010). Conventional thermal ALD is a special modification of the chemical vapor deposition (CVD) technique and relies on decoupling self-terminating (Puurunen, 2005b) gas-surface reactions (Masel, 1996). Precursors are injected in a non-overlapping alternate manner, separated by intermediate purge steps, and this prevents reaction in the gas-phase (Miikkulainen et al., 2013).

Industrial semiconductor processing has been a major stimulant for the development of the ALD process (Ritala and Niinisto, 2009; Sneh et al., 2002). Novel applications of ALD are expanding beyond semiconductor processing in several emerging areas, such as surface passivation layers in c-Si solar cells, buffer

14 layers in $\text{CuIn}_{1-x}\text{Ga}_x\text{Se}_2$ (CIGS) solar cells (Bakke et al., 2011), and diffusion
15 barrier layers in OLEDs and thin-film photovoltaics (Carcia et al., 2009). High-
16 throughput and low cost ALD production techniques are consequently becoming
17 ever-more necessary (Poodt et al., 2012). In this context, Wolden et al. (2011)
18 have pointed out that the development of comparative manufacturing techniques
19 requires sophisticated modeling to understand how to maintain cross-substrate
20 film thickness uniformity (Cleveland et al., 2012; Henn-Lecordier et al., 2011).

21 The development of validated, predictive physical ALD process models is
22 limited by a lack of reliable values for the parameters of the physicochemical
23 phenomena that govern the ALD film growth. Thus, the calibration and exper-
24 imental validation of models have been identified as an essential step in the field
25 (Semiconductor Industry Association, 2011). There are two generic method-
26 ologies for development of ALD reaction intrinsic kinetic mechanisms in the
27 literature:

- 28 i) Methods based on *ab initio* quantum chemistry, in which the energy pa-
29 rameters of the relevant gas-surface reactions are estimated using calcula-
30 tions based on density functions, and the associated rate parameters, us-
31 ing Rice-Ramsperger-Kassel-Marcus theory (Deminsky et al., 2004; Travis
32 and Adomaitis, 2013a,b). Elliott (2012) gives an overview of primary stud-
33 ies of ALD via atomic-scale simulation.
- 34 ii) Methods based on statistical model calibration and experimental valida-
35 tion, in which the kinetic parameters are obtained from *ex situ* experimen-
36 tal film characterization that elucidates ALD chemistry (Holmqvist et al.,
37 2013a; Lim et al., 2000; Park et al., 2000).

38 The ITRS, however, has suggested that *in situ* monitoring technologies, includ-
39 ing transmission Fourier transform infrared spectroscopy (Dillon et al., 1995;
40 Ferguson et al., 2000), quartz crystal microbalance (QCM) (Aarik et al., 1994a,b,
41 2001; Fan and Toyoda, 1992) and quadrupole mass spectroscopy (Juppo et al.,
42 2000; Lei et al., 2006; Rahtu and Ritala, 2002b), should be used to analyze
43 highly non-equilibrium ALD processes, in order to increase the accuracy of

44 the model calibration (Semiconductor Industry Association, 2011). These tech-
45 niques provide extensive real-time information of the process chemistry and
46 reactor conditions.

47 The overall objective of this study was to develop a general method to cali-
48 brate the parameters of reduced ALD reaction intrinsic kinetic mechanisms, in-
49 cluding only the principal sequential and parallel elementary surface reactions,
50 using *in situ* QCM diagnostics. This methodology developed was subsequently
51 applied to a case study in which thin ZnO films were deposited from $\text{Zn}(\text{C}_2\text{H}_5)_2$
52 and H_2O precursors. This paper focuses around three main points:

- 53 i) To investigate experimentally transient film growth in the continuous cross-
54 flow ALD reactor system F-120 manufactured by ASM Microchemistry
55 Ltd. (Suntola, 1992) with *in situ* QCM diagnostics.
- 56 ii) To develop a physically based model of continuous cross-flow, low-volume
57 ALD reactors with temporal precursor pulsing, and to incorporate ALD
58 surface reaction intrinsic kinetics.
- 59 iii) To formulate and solve a dynamic non-convex parameter estimation prob-
60 lem using measurements from the *in situ* QCM, and to assess the reliabil-
61 ities of the parameter estimates and the predicted model responses.

62 This paper is organized as follows. Section 2 presents the continuous cross-
63 flow ALD reactor system and the experimental investigation. Section 3 outlines
64 the ALD reaction intrinsic kinetic mechanism. Section 4 is dedicated to the
65 development of the ALD reactor model. Section 5 describes the formulation of
66 the dynamic non-convex parameter estimation problem, while Section 6 outlines
67 the modeling and optimization environment. Section 7 presents the primary
68 results from the statistical model calibration and experimental validation, and
69 Section 8 contains concluding remarks.

70 2. Reactor System Setup and Experimental Investigation

71 2.1. Process Description

72 The continuous cross-flow ALD reactor system F-120 (Fig. 1a) manufac-
73 tured by ASM Microchemistry Ltd. (Suntola, 1992) was used for the controlled
74 deposition of thin ZnO films from $\text{Zn}(\text{C}_2\text{H}_5)_2$ and H_2O precursors. Briefly, the
75 reactor setup incorporates actuator subsystems that provide flow control (FC)
76 of the carrier gas and each precursor inflow, \dot{Q}_α and $\alpha \in \{\text{N}_2, \text{Zn}(\text{C}_2\text{H}_5)_2, \text{H}_2\text{O}\}$,
77 and that enable alternate injections with variable dose times, Δt_α , of the α th
78 precursor. The normalized boxcar function, $\Pi_\alpha(t, \Delta t_\alpha) \in [0, 1]$, was used to
79 model non-overlapping precursor injections in a cyclic time sequence, where
80 this function is:

$$81 \quad \Pi_\alpha(t, \Delta t_\alpha) = \begin{cases} 1 & \gamma_\alpha \sum_{\beta \neq \alpha} \Delta t_\beta \leq \bar{t} \leq \gamma_\alpha \sum_{\beta \neq \alpha} \Delta t_\beta + \Delta t_\alpha \\ 0 & \text{otherwise} \end{cases} \quad (1)$$

82 in which $\bar{t} = (N_{\Delta t} - \lfloor N_{\Delta t} \rfloor) \Delta t$ is the normalized cycle time, $N_{\Delta t} = t(\Delta t)^{-1}$
83 is the cycle number, $\Delta t = \Delta t_{\text{Zn}(\text{C}_2\text{H}_5)_2} + \Delta t_{\text{N}_2} + \Delta t_{\text{H}_2\text{O}} + \Delta t_{\text{N}_2}$ denotes one
84 complete ALD cycle, and $[\gamma_{\text{Zn}(\text{C}_2\text{H}_5)_2}, \gamma_{\text{H}_2\text{O}}] = [0, 1]$.

85 The continuous inert gas flow, \dot{Q}_{N_2} , transports traveling waves of adsorptive
86 precursors laterally across the substrate holders, which are mounted on opposite
87 sides of the reaction chamber (RC), see Fig. 1b. The equipment has been
88 redesigned such that a wall-mounted quartz crystal resonator can be mounted
89 horizontally inside the chamber at the level of the surface of the custom-built
90 substrate holder, thereby avoiding any perturbation of the hydrodynamic flow
91 field (Riha et al., 2012; Yousfi et al., 2000). The rear of the crystal is exposed
92 to a higher partial pressure of N_2 to prevent back-side deposition (Elam et al.,
93 2002).

94 The reaction chamber and the precursor forelines are placed into a quartz
95 glass tube of length 1.20 (m), divided into five independently heated zones. The
96 temperature, T , is controlled by external induction heating that provides the de-
97 sired temperature profile. The temperature control (TC) equipment comprises

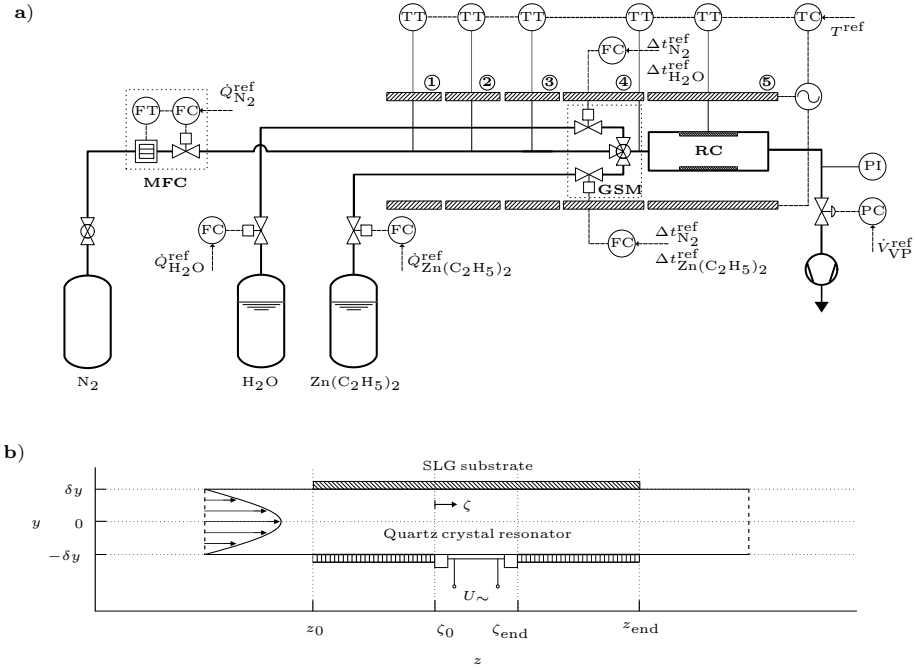

Figure 1: a) Simplified P&ID of the continuous cross-flow ALD reactor system F120 by ASM Microchemistry Ltd. (Suntola, 1992). It is noteworthy that the three-way gas switching mechanism (GSM) is an inherent physical structure of the RC inlet (see, e.g. Baunemann (2006)). b) Representation of the reaction chamber showing the wall-mounted quartz crystal resonator. The soda lime glass (SLG) substrate dimension is $z_{\text{end}} - z_0 = 5.0$ (cm) and the exposed quartz crystal dimension is $\zeta_{\text{end}} - \zeta_0 = 0.9$ (cm).

98 chromel-alumel thermocouples attached to the outside of the flow tube under
99 the heaters, maintained by PID controllers. Finally, the pressure, p , at the re-
100 action chamber outlet (subject to the total N_2 mass flow and temperature) is
101 maintained by pressure control (PC) equipment that comprises a rotary vane
102 vacuum pump (VP) operating at constant flow, \dot{V}_{VP} . The vector of manipu-
103 lated variables is thus $\mathbf{u} = [T, \dot{V}_{\text{VP}}, \dot{Q}_{\text{N}_2}, \Delta t_{\text{N}_2}, \dot{Q}_{\text{Zn}(\text{C}_2\text{H}_5)_2}, \Delta t_{\text{Zn}(\text{C}_2\text{H}_5)_2}, \dot{Q}_{\text{H}_2\text{O}},$
104 $\Delta t_{\text{H}_2\text{O}}]^T$.

105 *2.2. Instrumentation and Data Acquisition*

106 QCM measurements were obtained using a commercial Inficon SQM-160
107 thin film deposition monitor, from which the period of the QCM crystal was
108 recorded by a personal computer at 10.0 (Hz). The quartz crystals were AT-cut,
109 had a diameter of 1.9 (cm), and operated at a nominal frequency of 6.0 (MHz)
110 in the fundamental mode. A detailed description of the QCM used to monitor
111 ALD in viscous flow reactor designs has been previously presented: see, e.g.,
112 Elam et al. (2002). Assuming that the acoustic impedance of the deposited
113 film is equal to the acoustic impedance of an AT-cut crystal (Dunham et al.,
114 1995), the relationship between the change of resonant frequency, $\Delta\hat{f}_q$, and the
115 incremental change in mass, $\Delta\hat{m}_q$, can be obtained from the Sauerbrey equation
116 (Sauerbrey, 1959):

$$117 \quad \Delta\hat{f}_q = -\frac{2\hat{f}_{0,q}^2}{A_q(\mu_q\rho_q)^{\frac{1}{2}}}\Delta\hat{m}_q \quad (2)$$

118 in which $f_{0,q}$ is the fundamental resonant frequency, A_q the exposed surface area,
119 ρ_q the density of the quartz crystal, and μ_q its shear modulus. However, Eq. (2)
120 must be extended for heavily loaded crystals to incorporate the acousto-elastic
121 properties of the deposit (Lu and Lewis, 1972; Wajid, 1991).

122 In addition, reference values of the total mass gain per cycle (MGPC) (Wind
123 and George, 2010) were obtained from *ex situ* measurements conducted using
124 X-ray reflectivity (XRR) with a Philips X'pert MRD powder diffractometer
125 equipped with a slit system, see e.g. Holmqvist et al. (2012); Törndahl et al.
126 (2007) for detailed descriptions. These measurements were taken at the central
127 sampling position on the SLG substrate (see Fig. 1b) after $N_{\Delta t} = 2.5 \cdot 10^2$
128 (cycles), and were used to calibrate the MGPC, $d\Delta\hat{m}_q|_{\Delta t}(dN_{\Delta t})^{-1}$, extracted
129 from the film mass increment trajectories, $\Delta\hat{m}_q$. Table 1 lists MGPC values
130 obtained from experimental QCM and XRR measurements.

131 *2.3. Minimization of Temperature-induced Apparent QCM Mass Transients*

132 The QCM is extremely useful for probing the ALD surface reactions be-
133 cause of its submonolayer resolution and rapid time response. However, the

Table 1: Outline of the experimental design. The determined mass gain per cycle, $d\Delta\hat{m}_q|_{\Delta t}(dN_{\Delta t})^{-1}$, and the average number of hydroxyl groups that reacted with each $\text{Zn}(\text{C}_2\text{H}_5)_2$ molecule, $\hat{\nu}$, are listed for each experimental index, j . All experiments were performed with the following process operating parameters: $[\dot{Q}_{\text{Zn}(\text{C}_2\text{H}_5)_2}, \dot{Q}_{\text{H}_2\text{O}}, \dot{Q}_{\text{N}_2}] = [8.9, 3.7, 500.0]$ (sccm) [standard cubic centimeters per minute at STP]. It is noteworthy that the real pulse duration, Δt_α , is approximately equal to $1.12 \cdot \widetilde{\Delta t}$ and that $\forall \alpha \in \{\text{N}_2, \text{Zn}(\text{C}_2\text{H}_5)_2, \text{H}_2\text{O}\}$. The density, ρ_s , of the ZnO film deposited at $T = 150$ ($^\circ\text{C}$) was 5.4 (g cm^{-3}) when analyzed with XRR (Törndahl et al., 2007).

j	$\widetilde{\Delta t}_{\text{Zn}(\text{C}_2\text{H}_5)_2}$ (s)	$\widetilde{\Delta t}_{\text{H}_2\text{O}}$ (s)	$\widetilde{\Delta t}_{\text{N}_2}$ (s)	T ($^\circ\text{C}$)	$\frac{d\Delta\hat{m}_q _{\Delta t}}{dN_{\Delta t}}$ (\AA cycle^{-1})	$\hat{\nu}$ (a.u.)
1	0.4	0.4	0.8	100	0.55 ± 0.031	1.25 ± 0.172
2	0.4	0.4	2.0	100	0.56 ± 0.034	1.33 ± 0.210
3	1.0	1.0	2.0	100	1.12 ± 0.037	1.30 ± 0.118
4 ^a	2.0	2.0	2.0	100	1.62 ± 0.056	1.28 ± 0.084
5	0.4	0.4	0.8	125	1.32 ± 0.041	1.38 ± 0.079
6	0.4	0.4	2.0	125	1.30 ± 0.023	1.39 ± 0.059
7 ^a	1.0	1.0	2.0	125	1.77 ± 0.060	1.44 ± 0.066
8	2.0	2.0	2.0	125	1.97 ± 0.069	1.39 ± 0.076
9	0.4	0.4	0.8	150	1.66 ± 0.081	1.34 ± 0.082
10	0.4	0.4	2.0	150	1.63 ± 0.048	1.41 ± 0.067
11	1.0	1.0	2.0	150	1.94 ± 0.082	1.30 ± 0.102
12	2.0	2.0	2.0	150	2.05 ± 0.070	1.33 ± 0.084
13 ^a	0.4	0.4	0.8	175	1.80 ± 0.061	1.34 ± 0.101
14	0.4	0.4	2.0	175	1.78 ± 0.036	1.44 ± 0.064
15	1.0	1.0	2.0	175	2.00 ± 0.058	1.31 ± 0.106
16	2.0	2.0	2.0	175	2.06 ± 0.057	1.35 ± 0.150
17	0.4	0.4	0.8	200	1.80 ± 0.050	1.40 ± 0.129
18	0.4	0.4	2.0	200	1.76 ± 0.038	1.38 ± 0.053
19	1.0	1.0	2.0	200	1.98 ± 0.054	1.33 ± 0.109
20	2.0	2.0	2.0	200	2.04 ± 0.066	1.35 ± 0.070
i ^b	0.4	0.4	0.8	100	0.55	
ii ^b	0.4	0.4	0.8	125	1.32	
iii ^b	0.4	0.4	0.8	150	1.66	
iv ^b	0.4	0.4	0.8	175	1.80	
v ^b	0.4	0.4	0.8	200	1.80	

^aExperimental validation set.

^b*Ex situ* XRR references set with $N_{\Delta t} = 2.5 \cdot 10^2$ (cycles).

134 most serious limitation to the QCM technique is that the resonant frequency
135 of the AT-cut quartz crystal is dependent on temperature (Elam et al., 2002;
136 Elam and Pellin, 2005). Consequently, fluctuations in temperature lead to large
137 fluctuations in apparent mass. Rocklein and George (2003) demonstrated that
138 temperature transients caused by gas pulsing can be minimized by tuning the
139 temperature profile along the zones that lie upstream of the reaction chamber.
140 Many studies have subsequently shown that nearly ideal ALD growth that be-
141 haves according to the expectations from the ALD surface chemistry can be
142 successfully monitored once the temperature profile has been optimized to min-
143 imize the temperature-induced apparent mass changes (see, e.g. Larrabee et al.
144 (2013); Riha et al. (2012) and the reference cited therein).

145 In this study, the temperature profile prescribed by the four individually
146 heated zones upstream of the RC (see Fig. 1) was tuned for each deposition
147 temperature studied (see Table 1) in order to minimize the temperature-induced
148 mass changes when a fully hydroxylated QCM sensor was exclusively exposed
149 to the H₂O precursor. Hence, no ALD growth is expected to occur in these con-
150 ditions and the apparent mass change was a result of temperature fluctuations.
151 Furthermore, baseline subtraction of the temperature-induced drift (Rahtu and
152 Ritala, 2002a) was not considered necessary.

153 *2.4. Experimental Investigation*

154 The experimental design was intended to assess the impact of Δt_α , $\alpha \in$
155 $\{\text{N}_2, \text{Zn}(\text{C}_2\text{H}_5)_2, \text{H}_2\text{O}\}$, and the RC temperature, T , on the rate at which the
156 film was deposited. Furthermore, the design ensured that the experiments gave
157 the maximum possible information, in a statistical sense, which maximized the
158 capacity to discriminate between calibration parameters (Franceschini and Mac-
159 chietto, 2008). The ALD reactor was operated in a wide range of process condi-
160 tions in order to understand the complex interdependence between the sequen-
161 tial and parallel elementary surface reactions. This complexity arises in that the
162 reactivity in one half-cycle is influenced by that in the half-cycle that precedes
163 it (Kuse et al., 2003; Ritala and Leskelä, 2002). The examined range of process

164 conditions defines the region of validity of the model and includes the bounds
 165 of the ALD window (Yousfi et al., 2000) for both saturated and non-saturated
 166 (Park et al., 2000) deposition. The dose times for $\text{Zn}(\text{C}_2\text{H}_5)_2$ and H_2O were
 167 varied between $\widetilde{\Delta t}_\alpha \in [0.4, 2.0]$ (s), with purge times in the range $\widetilde{\Delta t}_\beta \in [0.8, 2.0]$
 168 (s) between precursor pulses (see Table 1). The N_2 purge times were intention-
 169 ally longer than necessary to separate the QCM signals that resulted from the
 170 individual precursor exposures (Jur and Parsons, 2011). Rocklein and George
 171 (2003) have shown also that long purge times decrease the QCM error.

172 In this study, datasets of $N_{\Delta t} \geq 50$ (cycles) were collected for each exper-
 173 imental case, j , and the average mass increment trajectory, $\langle \Delta \hat{m}_q \rangle$, was used
 174 for experimental validation, see Fig. 2. The rate of deposition deviated from
 175 constant MGPC, $d^2 \Delta \hat{m}_q |_{\Delta t} (dN_{\Delta t}^2)^{-1} \neq 0$, during the first $N_{\Delta t} \leq 25$ (cycles) for
 176 every combination $j \in \{1, 2, \dots, N_j\}$ of dose times. These changes have been
 177 attributed to the terminal coverage of active surface sites (Holmqvist et al.,
 178 2012) from the previous experimental case, j , and their extent is ultimately
 179 determined by the precursor dose times. Thus, we considered that the data
 180 collected from the $N_{\Delta t} > 25$ (cycles) of growth did not suffer from this com-
 181 plication, and used this data to determine $\langle \Delta \hat{m}_q \rangle$ and the associated deviation,
 182 $\hat{\sigma}_{\langle \Delta \hat{m}_q \rangle}$. Furthermore, the average number of hydroxyl groups that reacted with
 183 each $\text{Zn}(\text{C}_2\text{H}_5)_2$ molecule, $\hat{\nu}$, was determined from the ratio of mass change that
 184 occurred during the half-reactions (Elam and George, 2003) (see Table 1). The
 185 QCM mass ratio for ZnO ALD is given by:

$$186 \quad \frac{\widehat{\Delta M}_B}{\widehat{\Delta M}_A} = \frac{M_{\text{H}_2\text{O}} - (2 - \hat{\nu})M_{\text{C}_2\text{H}_6}}{M_{\text{Zn}(\text{C}_2\text{H}_5)_2} - \hat{\nu}M_{\text{C}_2\text{H}_6}} \quad (3)$$

187 in which the quotients of the differences in molecular masses of the outermost
 188 surface species, i.e. $\widehat{\Delta M}_B(\widehat{\Delta M}_A)^{-1}$, were extracted from the QCM trajec-
 189 tories (see Fig. 2). The temperature averaged mean value of the number of
 190 reacting hydroxyl groups was determined to $\langle \hat{\nu} \rangle = 1.361 \pm 0.030$, based on
 191 the mean values of $\hat{\nu}$ at each temperature in the range $T \in [100, 200]$ ($^\circ\text{C}$).
 192 This value can be compared with that determined by Elam and George (2003),
 193 $\nu = 1.37$ at $T = 177$ ($^\circ\text{C}$). In addition, the full monolayer-limiting molar

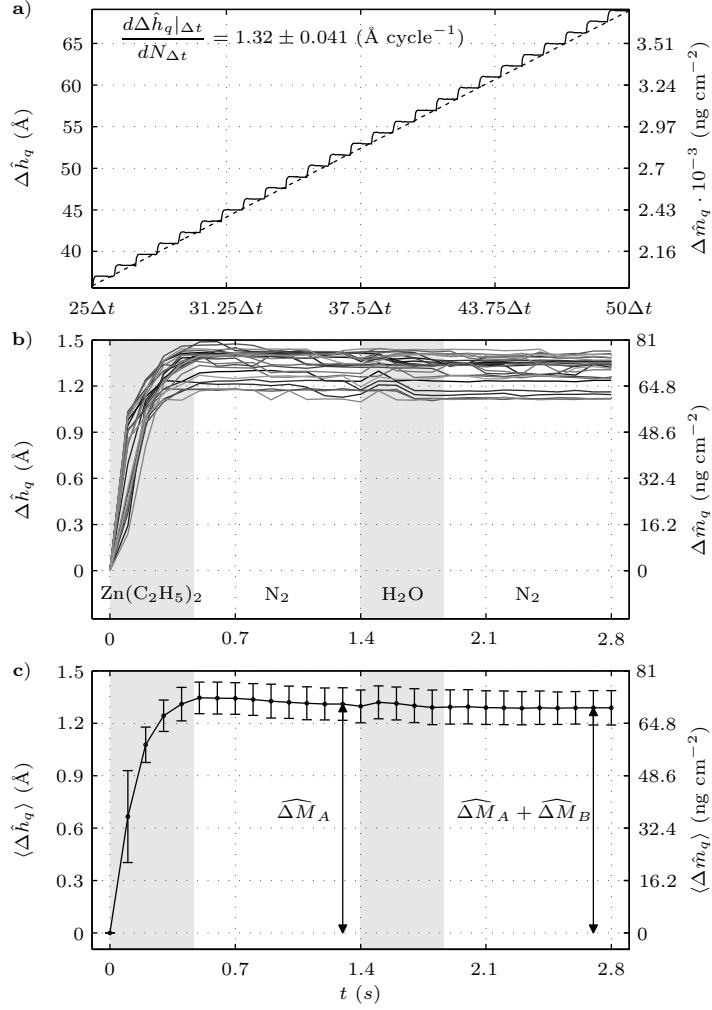

Figure 2: a) Apparent mass trajectory, $\Delta\hat{m}_q$, as a function of time for the experimental index $j = 5$ (Table 1 gives the process operating conditions). MGPCs, $d\Delta\hat{m}_q|_{\Delta t}(dN_{\Delta t})^{-1}$, have been calibrated using reference *ex situ* XRR thickness measurements. b) Fractionation of the apparent mass trajectory into individual ALD cycles, $t \in [0, \Delta t]$ (s). The shaded rectangles indicate the precursor pulse interval endpoints. c) Estimated mean mass gain, $\langle\Delta\hat{m}_q\rangle$, and associated confidence intervals, $\sigma_{\langle\Delta\hat{m}_q\rangle}$, from the individual ALD cycles.

194 concentration of surface sites, Λ_{ML} , can be deduced from the density of the
 195 ZnO film $\rho_s = 5.4 \cdot 10^3$ (kg m⁻³) (Törndahl et al., 2007), using the definition

196 $\Lambda_{\text{ML}} = (\rho_{\text{s}} M_{\text{s}}^{-1} \tilde{N})^{2/3} \tilde{N}^{-1} = 1.94 \cdot 10^{-5}$ (mol m^{-2}), which corresponds to a
 197 film monolayer thickness $h_{\text{ML}} = 2.93$ (\AA cycle^{-1}). Full theoretical monolayer
 198 growth is normally not reached, however, and steric hindrance determines when
 199 saturation occurs, at which the ligand packing is at its real maximum (Pu-
 200 urunen, 2003). Travis and Adomaitis (2013b) have recently used the ligand
 201 group concentration at the close-packing limit experimentally determined by
 202 Puurunen (2005a) to compute the limiting surface concentrations associated
 203 with saturating ALD growth per cycle. Corresponding data are not available
 204 for the precursors used in the present study, and the limiting molar concentra-
 205 tion of surface sites, $\Lambda = 1.37 \cdot 10^{-5}$ (mol m^{-2}), was instead determined from
 206 the maximum growth per cycle, $\max d\Delta \hat{m}_q|_{\Delta t} (dN_{\Delta t})^{-1}$, (see Table 1). Finally,
 207 it is noteworthy that only this quasi-steady state growth regime is considered
 208 in this experimental investigation and, consequently, elementary surface reac-
 209 tions of the initial regime (Alam and Green, 2003; Puurunen, 2004), in which
 210 $d^2 \Delta \hat{m}_q|_{\Delta t} (dN_{\Delta t}^2)^{-1} \neq 0$, were excluded.

211 3. ALD Reaction Intrinsic Kinetic Mechanism

212 It was assumed that both the $\text{Zn}(\text{C}_2\text{H}_5)_2$ and the H_2O half-reactions proceed
 213 through the trapping-mediated mechanism, analogous to that proposed by Ren
 214 (2009):

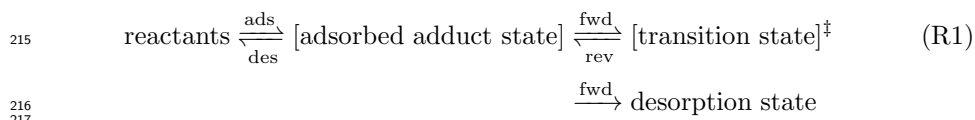

218 where the reactions under consideration proceed through stable intermediate
 219 transition complexes formed by the species in the gas-phase reacting with an ac-
 220 tive surface site through a typical donor–acceptor coordination bond (Deminsky
 221 et al., 2004; Musgrave, 2012; Travis and Adomaitis, 2013b). The elementary
 222 gas–surface reaction mechanisms for the $\text{Zn}(\text{C}_2\text{H}_5)_2$ precursor and a normally

223 hydroxylated surface are thus:

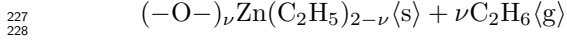
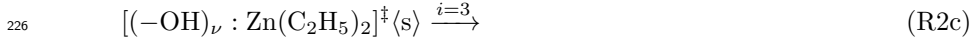
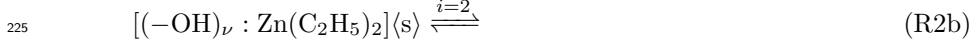
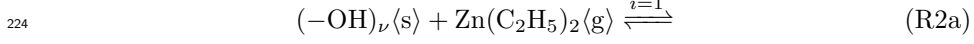

229 in which $\langle \text{s} \rangle$ and $\langle \text{g} \rangle$ denote the surface and gaseous species, respectively, and ν is
 230 the average number of hydroxyl groups that react with each $\text{Zn}(\text{C}_2\text{H}_5)_2$ molecule
 231 (Elam and George, 2003; Yousfi et al., 2000). The adsorption and decomposition
 232 of H_2O at the $(-\text{O}-)_\nu \text{Zn}(\text{C}_2\text{H}_5)_{2-\nu} \langle \text{s} \rangle$ surface site occur sequentially:

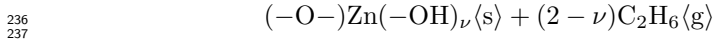
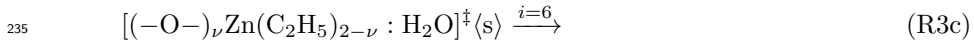
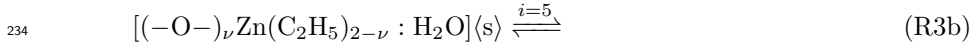
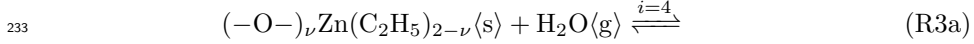

238 It is assumed that the elimination reaction ($i = \{3, 6\}$) is irreversible in both
 239 half-reactions due to the removal of C_2H_6 , and that it is the rate-limiting step of
 240 the sequence of reactions. The intermediate complexes in Reactions (R2 and R3)
 241 have a significant adsorption energy, which becomes important at low tempera-
 242 tures ($T < 200$ ($^\circ\text{C}$)), where the growth rate of the film can decrease significantly
 243 due to the stabilization of the adsorption complex (Ren, 2009). The apparent
 244 fall in MGPC at high temperatures is generally attributed to a gradual decrease
 245 in the density of the surface hydroxyl groups (Deminsky et al., 2004; Matero
 246 et al., 2000; Rahtu et al., 2001). This decrease results from an increase in the
 247 rate of the recombination reaction with increasing temperature. Reactions (R2
 248 and R3), however, suppose that the entropy of the gas-phase precursor molecules
 249 increases significantly as the temperature increases, making desorption of the
 250 adsorbed precursor more favorable, and consequently lowering the equilibrium
 251 surface coverage. This causes the growth rate to fall (Travis and Adomaitis,

Table 2: Summary of gaseous and fractional surface coverage species in Reactions (R2 and R3), with their abbreviations.

Gaseous species ($\langle\langle g \rangle\rangle$)	α	Surface species ($\langle\langle s \rangle\rangle$)	κ
Zn(C ₂ H ₅) ₂	<i>A</i>	(-OH)	<i>A*</i>
H ₂ O	<i>B</i>	[(-OH) _{ν} : Zn(C ₂ H ₅) ₂]	<i>B*</i>
C ₂ H ₆	<i>C</i>	[(-OH) _{ν} : Zn(C ₂ H ₅) ₂] [‡]	<i>C*</i>
N ₂	<i>P</i>	(-C ₂ H ₅) _{2-ν}	<i>D*</i>
		[(-O-) _{ν} Zn(C ₂ H ₅) _{2-ν} : H ₂ O]	<i>E*</i>
		[(-O-) _{ν} Zn(C ₂ H ₅) _{2-ν} : H ₂ O] [‡]	<i>F*</i>

252 2013b; Widjaja and Musgrave, 2002a,b). Table 2 lists the abbreviations for the
 253 gaseous and fractional surface species in Reactions (R2 and R3).

254 4. Physical Modeling

255 The modeling of an ALD continuous flow reactor system can be performed at
 256 several levels of detail and with various assumptions (see e.g. (Aarik and Siimon,
 257 1994; Yanguas-Gil and Elam, 2012; Ylilammi, 1995)). The level of detail chosen
 258 depends on the goal of the modeling, as defined by Hango and Cameron (2001),
 259 and how the model is to be applied. Despite the diversity of published work
 260 in the field, the deposition process depends strongly on the characteristic time
 261 scales (Adomaitis, 2010; Granneman et al., 2007), on the underlying reactor-
 262 scale mass transport (Aarik et al., 2006; Jur and Parsons, 2011; Mousa et al.,
 263 2012), and on the reaction mechanism at the gas-surface interface (Ritala and
 264 Leskelä, 2002).

265 4.1. Formulation of Underlying Model Assumptions

266 The model described here was based on the two-dimensional model described
 267 in a recently published three-part article series (Holmqvist et al., 2012, 2013a,b).
 268 Several assumptions have been made in order to simplify the overall modeling
 269 framework and reduce the computational requirements, without sacrificing the
 270 accuracy and applicability of the model. Some of the assumptions arise from the

271 operation of the ALD reactor system (see Section 2.1), while others are based
 272 on theory (Holmqvist et al., 2012). The additional theory related assumptions
 273 made in the work presented here are:

274 i) That the one-dimensional representation of the spatial domain, $z \in [z_0, z_{\text{end}}]$,
 275 subject to fully developed channel flow with the z-axis coincident with the
 276 apex of the direction of the flow (Bird et al., 1960):

$$277 \quad v_z(y) := v_{z,\text{max}} \left(1 - \left[\frac{y}{\delta y} \right]^2 \right) \quad (4)$$

278 is sufficiently accurate. This assumption implies that the velocity of the
 279 flow in contact with the plates is zero, so that $v_z = 0$ at $y = \pm \delta y$, and
 280 $v_{z,\text{max}} := (3/2)v_z$ (see Fig. 1b). Eq. (4) shows that the shear stress is:

$$281 \quad \Phi_z = \frac{\partial}{\partial y} \left(-\mu \frac{\partial v_z(y)}{\partial y} \right) := \left(\frac{3}{\delta y^2} \right) \mu v_z \quad (5)$$

282 ii) That a steady-state representation of the reversible chemisorption of pre-
 283 cursors ($i = \{1, 4\}$) in Reactions (R2 and R3) is sufficiently accurate,
 284 and that the reaction rates of the consecutive forward and reverse surface
 285 reactions ($i = \{2, 5\}$) establish a dynamic equilibrium.

286 4.2. Governing Equations of the ALD Reactor Sub-model

287 The mathematical model of the low-volume, continuous cross-flow ALD reac-
 288 tor with temporal precursor pulsing is based on fully coupled, compressible equa-
 289 tions (Bird et al., 1960) for the conservation of mass, momentum, and individual
 290 gas-phase species defined in the one-dimensional spatial domain, $z \in [z_0, z_{\text{end}}]$.
 291 The model uses transient conditions for all governing equations in the temporal
 292 domain, $t \in [t_0, t_f]$, in order to capture details of the process dynamics at the
 293 level of a single ALD pulse sequence:

$$294 \quad \frac{\partial \rho}{\partial t} = -\frac{\partial}{\partial z} (\rho v_z) + \sum_{\forall \alpha} S_\alpha \quad (6)$$

$$295 \quad \rho \frac{\partial v_z}{\partial t} + v_z \frac{\partial \rho}{\partial t} = -\frac{\partial}{\partial z} \left(\rho v_z v_z - \frac{4}{3} \mu \frac{\partial v_z}{\partial z} + p \right) - \Phi_z \quad (7)$$

$$296 \quad \rho \frac{\partial \omega_\alpha}{\partial t} + \omega_\alpha \frac{\partial \rho}{\partial t} = -\frac{\partial}{\partial z} \left(\rho \omega_\alpha v_z - \rho \mathcal{D}_{\alpha\beta} \frac{\partial \omega_\alpha}{\partial z} \right) + S_\alpha \quad (8)$$

297 in which ω_α denotes the mass fraction of the α th gas-phase species, and ρ is
 298 the density of the gas mixture. The pressure, p , is governed by the equation of
 299 state:

$$300 \quad p = \frac{\rho}{M} RT \quad (9)$$

$$301 \quad \frac{1}{M} = \sum_{\forall \alpha} \frac{\omega_\alpha}{M_\alpha} \quad (10)$$

302 The sum over all chemical reaction source terms, S_α , does not drop out in Eq.
 303 (6) because the total mass is not conserved in the ALD gas–surface reactions.
 304 The transport coefficients, $\mathcal{D}_{\alpha\beta}$ and μ_α , were determined from the Chapman–
 305 Enskog kinetic theory of dilute gases (Hirschfelder et al., 1964; Reid et al., 1988),
 306 while the viscosity for the multicomponent mixture of gases, μ , was determined
 307 using the semi-empirical mixing formula (Wilke, 1950).

308 4.2.1. Boundary Conditions

309 The inlet, $z = z_0$, boundary condition prescribes that the mass flow is a
 310 standard volumetric flow rate. Hence, the mass fluxes for each component and
 311 for the gas mixture, along with a Neumann condition on the velocity, are given
 312 by the equations:

$$313 \quad (\rho v_z) \Big|_{z=z_0} = \frac{1}{A'} \sum_{\forall \alpha} \rho_{\text{STP},\alpha} \dot{Q}_\alpha \Pi_\alpha(t, \Delta t_\alpha) \quad (11)$$

$$314 \quad \frac{\partial v_z}{\partial z} \Big|_{z=z_0} = 0 \quad (12)$$

$$315 \quad \left(\rho \omega_\alpha v_z - \rho \mathcal{D}_{\alpha\beta} \frac{\partial \omega_\alpha}{\partial z} \right) \Big|_{z=z_0} = \frac{1}{A'} \rho_{\text{STP},\alpha} \dot{Q}_\alpha \Pi_\alpha(t, \Delta t_\alpha) \quad (13)$$

316 Moreover, the outlet, $z = z_{\text{end}}$, boundary condition prescribes that the diffusive
 317 mass is zero, along with a Dirichlet condition on the velocity:

$$318 \quad \frac{\partial \omega_\alpha}{\partial z} \Big|_{z=z_{\text{end}}} = 0 \quad (14)$$

$$319 \quad v_z \Big|_{z=z_{\text{end}}} = \frac{\dot{V}_{\text{VP}}}{A'} \quad (15)$$

320 where \dot{V}_{VP} denotes the constant flow rate for the vacuum pump (see Fig. 1a).

321 *4.3. Governing Equations of the ALD Film Growth Sub-model*

322 The general surface reaction model that describes the spatial and temporal
323 fractional surface coverage is:

$$324 \quad \frac{\partial \Lambda \theta_\kappa}{\partial t} = \sum_{i=1}^{N_i} \xi_{\kappa,i} r_i \quad (16a)$$

$$325 \quad 0 = \sum_{\forall \kappa} \frac{\partial \Lambda \theta_\kappa}{\partial t} \quad (16b)$$

326 where Λ denotes the maximum molar concentration of surface sites per unit
327 substrate area that are available for deposition. The heterogeneous ALD gas–
328 surface reactions mean that there will be a net mass consumption at the sub-
329 strate surface, and thus the fractional surface coverage dynamics of Eq. (16)
330 governs the source term, S_α , of the continuity equation for the precursor density
331 (see also Eq. (8)):

$$332 \quad S_\alpha = -\frac{A_{\text{sub}}}{V_{\text{RC}}} M_\alpha \left[\sum_{\forall \kappa} \xi_{\alpha,\kappa} \frac{\partial \Lambda \theta_\kappa}{\partial t} - \sum_{i=1}^{N_i} \xi_{\kappa,i}^{\text{fwd},\text{fwd}} r_i^{\text{fwd}} \right] \quad (17)$$

333 where $\xi_{\alpha,\kappa}$ denotes the stoichiometric coefficient that corresponds to the α th
334 species. Consequently, the mass accumulated from the adsorption/chemisorption
335 of the precursor on the surface per unit QCM sensor area is given by:

$$336 \quad \frac{d\langle m_q \rangle}{dt} = \frac{1}{(\zeta_{\text{end}} - \zeta_0)} \int_{\zeta_0}^{\zeta_{\text{end}}} \left[\sum_{\forall \alpha} M_\alpha \sum_{\forall \kappa} \xi_{\alpha,\kappa} \frac{\partial \Lambda \theta_\kappa}{\partial t} + \sum_{i=1}^{N_i} \Delta M_i r_i^{\text{fwd}} \right] d\zeta \quad (18)$$

337 in which $\zeta \in [\zeta_0, \zeta_{\text{end}}]$ is the spatial coordinate variable of the exposed quartz
338 crystal surface. The mass gain in Eq. (18), for the integration limits $\zeta \in$
339 $[z_0, z_{\text{end}}]$, equals the mass loss in Eq. (6): $V_{\text{RC}}(A_{\text{sub}})^{-1} \sum_{\forall \alpha} S_\alpha$.

340 Finally, the molar reaction rate of the i th elementary gas–surface and surface
341 reaction in Eqs. (16–18) is given by the general formulation:

$$342 \quad r_i^{\text{eq}} = k_i^{\text{ads}} p_\alpha \left(\Lambda - \sum_{\forall \ell} \Lambda \theta_\ell \right)^{n_i^{\text{ads}}} - k_i^{\text{des}} \left(\Lambda \theta_\kappa \right)^{n_i^{\text{des}}} \quad (19a)$$

$$343 \quad r_i^{\text{fwd}} = k_i^{\text{fwd}} \left(\Lambda \theta_\kappa \right)^{n_i^{\text{fwd}}} \quad (19b)$$

344

345 in which the subscript ℓ represents all κ th surface species with which the α th
 346 gaseous species cannot undergo a reaction, n_i^{ads} is the adsorption order related
 347 to the interaction between adsorbents, and n_i^{des} is the corresponding desorption
 348 order. Hence, imposing the equilibrium relationship, $r_i^{\text{eq}} := 0$, allows to rewrite
 349 Eq. (19a) as (introducing $K_i^{\text{eq}} = k_i^{\text{ads}}(k_i^{\text{des}})^{-1}$):

$$350 \quad 0 = K_i^{\text{eq}} p_\alpha \left(\Lambda - \sum_{\forall \ell} \Lambda \theta_\ell \right)^{n_i^{\text{ads}}} - \left(\Lambda \theta_\kappa \right)^{n_i^{\text{des}}} \quad (19c)$$

351 The temperature dependency of the forward, k_i^{fwd} , adsorption, k_i^{ads} , and des-
 352 orption, k_i^{des} , rate constants is governed by reparameterization of the Arrhenius
 353 equation by introducing a reference temperature, $T_{\text{ref},i}$, in the form (Schwaab
 354 et al., 2008; Schwaab and Pinto, 2007, 2008):

$$355 \quad k_i = k_{T_{\text{ref},i}} \exp\left(-\frac{E_i}{R} \left[\frac{1}{T} - \frac{1}{T_{\text{ref},i}} \right]\right) \quad (20a)$$

$$356 \quad k_{T_{\text{ref},i}} = A_i \exp\left(-\frac{E_i}{R} \frac{1}{T_{\text{ref},i}}\right) \quad (20b)$$

358 where $k_{T_{\text{ref},i}}$ is the specific reaction rate coefficient at $T_{\text{ref},i}$, A_i is the frequency
 359 factor, and E_i is the activation energy of the i th elementary reaction. The
 360 expression for chemical reactions in equilibrium is thus:

$$361 \quad K_i^{\text{eq}} = \frac{k_i^{\text{ads}}}{k_i^{\text{des}}} = K_{T_{\text{ref},i}}^{\text{eq}} \exp\left(-\frac{\Delta E_i^{\text{eq}}}{R} \left[\frac{1}{T} - \frac{1}{T_{\text{ref},i}^{\text{eq}}} \right]\right) \quad (20c)$$

362 in which $K_{T_{\text{ref},i}}^{\text{eq}} := k_{T_{\text{ref},i}}^{\text{ads}}(k_{T_{\text{ref},i}}^{\text{des}})^{-1}$, $\Delta E_i^{\text{eq}} := E_i^{\text{ads}} - E_i^{\text{des}}$, and $T_{\text{ref},i}^{\text{eq}} := T_{\text{ref},i}^{\text{ads}} =$
 363 $T_{\text{ref},i}^{\text{des}}$.

364 4.3.1. Surface State Limit-cycle Dynamics

365 The differential-algebraic equation (DAE) system that governs the fractional
 366 surface-coverage species, θ_κ , and that gives the dynamics for both ALD half-

367 reactions (Reactions (R2 and R3)) is:

$$368 \quad \xi_{B^*,1}^{\text{eq}} \frac{\partial \Lambda \theta_{A^*}}{\partial t} + \xi_{A^*,1}^{\text{eq}} \frac{\partial \Lambda \theta_{B^*}}{\partial t} = -\xi_{A^*,1}^{\text{eq}} \xi_{B^*,2}^{\text{eq}} r_2^{\text{eq}} + \xi_{B^*,1}^{\text{eq}} \xi_{A^*,6}^{\text{fwd}} r_6^{\text{fwd}} \quad (21a)$$

$$369 \quad \frac{\partial \Lambda \theta_{C^*}}{\partial t} = \xi_{C^*,2}^{\text{eq}} r_2^{\text{eq}} - \xi_{C^*,3}^{\text{fwd}} r_3^{\text{fwd}} \quad (21b)$$

$$370 \quad \xi_{E^*,4}^{\text{eq}} \frac{\partial \Lambda \theta_{D^*}}{\partial t} + \xi_{D^*,4}^{\text{eq}} \frac{\partial \Lambda \theta_{E^*}}{\partial t} = -\xi_{D^*,4}^{\text{eq}} \xi_{E^*,5}^{\text{eq}} r_5^{\text{eq}} + \xi_{E^*,4}^{\text{eq}} \xi_{D^*,3}^{\text{fwd}} r_3^{\text{fwd}} \quad (21c)$$

$$371 \quad \frac{\partial \Lambda \theta_{F^*}}{\partial t} = \xi_{F^*,5}^{\text{eq}} r_5^{\text{eq}} - \xi_{F^*,6}^{\text{fwd}} r_6^{\text{fwd}} \quad (21d)$$

$$372 \quad 0 = K_1^{\text{eq}} p_A (\Lambda \theta_{A^*})^{n_1^{\text{ads}}} - (\Lambda \theta_{B^*})^{n_1^{\text{des}}} \quad (21e)$$

$$373 \quad 0 = K_4^{\text{eq}} p_B (\Lambda \theta_{D^*})^{n_4^{\text{ads}}} - (\Lambda \theta_{E^*})^{n_4^{\text{des}}} \quad (21f)$$

375 The sum of Eqs. (21a–21d) is zero, and Eq. (16b) is thus fulfilled. Furthermore,
 376 the mathematical formulation of the i th equilibrium, r_i^{eq} , and forward reactions
 377 rates, r_i^{fwd} , (see Eq. (19)) in Eq. (21) are:

$$378 \quad r_2^{\text{eq}} = k_2^{\text{fwd}} (\Lambda \theta_{B^*})^{n_2^{\text{fwd}}} - k_2^{\text{rev}} (\Lambda \theta_{C^*})^{n_2^{\text{rev}}} \quad (22a)$$

$$379 \quad r_5^{\text{eq}} = k_5^{\text{fwd}} (\Lambda \theta_{E^*})^{n_5^{\text{fwd}}} - k_5^{\text{rev}} (\Lambda \theta_{F^*})^{n_5^{\text{rev}}} \quad (22b)$$

$$380 \quad r_3^{\text{fwd}} = k_3^{\text{fwd}} (\Lambda \theta_{C^*})^{n_3^{\text{fwd}}} \quad (22c)$$

$$381 \quad r_6^{\text{fwd}} = k_6^{\text{fwd}} (\Lambda \theta_{F^*})^{n_6^{\text{fwd}}} \quad (22d)$$

383 It is, however, worth noting that Eq. (21) must be reformulated before the
 384 dynamic optimization problem is considered. The remaining kinetic parameters,
 385 including the specific reaction rate at $T_{\text{ref},i}$, $k_{T_{\text{ref},i}}$, and the associated activation
 386 energy, E_i , for the i th elementary surface reaction (Reactions (R2 and R3)) can
 387 be gathered into a calibration parameter vector $\boldsymbol{\beta} \in \mathbb{R}^{N_\beta}$:

$$388 \quad \boldsymbol{\beta} = [K_{T_{\text{ref},i}}^{\text{eq}}, \Delta E_i^{\text{eq}}, k_{T_{\text{ref},j}}^{\text{fwd}}, E_j^{\text{fwd}}, k_{T_{\text{ref},\ell}}^{\text{rev}}, E_\ell^{\text{rev}}]^T \quad (23)$$

389 where $i \in \{1, 4\}$, $j \in \{2, 3, 5, 6\}$, $\ell \in \{2, 5\}$, and where $\mathbf{T}_{\text{ref}} = [T_{\text{ref},i}^{\text{eq}}, T_{\text{ref},j}^{\text{fwd}}, T_{\text{ref},\ell}^{\text{rev}}]^T$
 390 is a vector that collects all reference temperatures. Finally, all exponential fac-
 391 tors, n_i , are set to unity and the stoichiometric coefficients $\xi_{\kappa,i}$ and $\forall i$ associated
 392 with the i th elementary gas–surface and surface reaction are defined according
 393 to Reactions (R2 and R3).

394 4.4. Limit-cycle Solutions

395 The ALD reactor sub-model and film growth sub-model described above can
396 be used to study the dynamic nature of precursor pulsation and the resulting
397 film growth process as a function of surface state initial conditions and process
398 operating parameters. However, computing the limit-cycle solution over the
399 time horizon $[t_0, t_f]$ requires one additional important criterion; that the state
400 of the surface returns to its initial condition at the end of the cycle, $t = t_f$
401 (Travis and Adomaitis, 2013a,b):

$$402 \quad \theta_\kappa(t_0) := \theta_\kappa(t_f), \quad \forall \kappa \in \{A^*, \dots, F^*\} \quad (24a)$$

403 In addition, the non-differentiated form of Eq. (16b) must be satisfied at $t \in$
404 $\{t_0, t_f\}$:

$$405 \quad 1 = \sum_{\forall \kappa} \theta_\kappa(t) \quad (24b)$$

406 Eq. (24b) reduces the number of free variables of the initial equations to $N_\kappa - 1$.
407 Section 6 presents numerical aspects of computing limit-cycle solutions.

408 4.5. Model Form and Size

409 The non-linear partial differential algebraic equations (PDAEs) of the ALD
410 reactor sub-model (see Section 4.2) and the film growth sub-model (see Section
411 4.3) were approximated using the method-of-lines (Davis, 1984; Schiesser, 1991)
412 and the finite volume method (FVM). In this study, FVM was used mainly
413 due to its mass conservation property (Fornberg, 1988) and because it is easy
414 to implement, in particular at the system boundaries. The first-order spatial
415 derivative of the density, ρ , in Eq. (6) and of the gas-phase mass fractions,
416 ω_α , in Eq. (8) have been approximated using a first-order downwind discretiza-
417 tion scheme, while a first-order upwind discretization scheme was utilized to
418 approximate the bulk velocity, v_z , in Eq. (7), yielding a large system of non-
419 linear differential algebraic equations. Thus, the process model may be written

420 collectively as a general non-linear index-1 DAE system as:

$$421 \quad \mathbf{0} = \mathbf{F}(\dot{\mathbf{x}}(t), \mathbf{x}(t), \mathbf{u}(t), \mathbf{w}(t), \boldsymbol{\beta}) \quad (25a)$$

$$422 \quad \mathbf{0} = \mathbf{F}_0(\dot{\mathbf{x}}(t_0), \mathbf{x}(t_0), \mathbf{u}(t_0), \mathbf{w}(t_0), \boldsymbol{\beta}) \quad (25b)$$

$$423 \quad \mathbf{0} = \mathbf{C}_e(t_0, t_f, \mathbf{x}_e, \mathbf{u}_e, \mathbf{w}_e, \boldsymbol{\beta}) \quad (25c)$$

$$424 \quad \mathbf{x}(t_0) = \mathbf{x}_0 \quad (25d)$$

425 in which \mathbf{F} is the DAE that represents the dynamics of the system, \mathbf{F}_0 repre-
 426 sent the DAE augmented with initial conditions, and \mathbf{C}_e is a point equality-
 427 constraint function that assures that the limit-cycle criterion (see Eq. (24a)) is
 428 fulfilled. Finally, \mathbf{x} , \mathbf{u} and \mathbf{w} represent dependent states, free design variables
 429 (see Section 2.1), and algebraic variables:

$$430 \quad \mathbf{x} = [\rho, v_z, \omega_\alpha, \theta_\kappa, m_q]^T, \quad \alpha \in \{A, B, C\}, \kappa \notin \{B^*, E^*\}$$

$$431 \quad \mathbf{w} = [p, \bar{M}, \theta_\kappa]^T, \quad \kappa \in \{B^*, E^*\}$$

$$432 \quad \mathbf{y} = \langle m_q \rangle$$

$$433 \quad \mathbf{u} = [\Delta t_\alpha, \dot{Q}_\alpha, T, \dot{V}_{VP}]^T, \quad \alpha \in \{A, B, P\}$$

435 Consequently, when the number of FVM elements, N_{FVM} , is 20, the number of
 436 states, N_x , is $10N_{\text{FVM}}$ and the number of algebraic variables, N_w , is $4N_{\text{FVM}}$.
 437 The number of FVM elements is a compromise between accuracy and compu-
 438 tational complexity, and gives adequate representation of the dispersion.

439 5. Dynamic Parameter Estimation

440 5.1. Non-convex Dynamic Optimization Problem Formulation

441 The dynamic parameter estimation problem aims to solve for the calibration
 442 parameter vector, $\boldsymbol{\beta} \in \mathbb{R}^{N_\beta}$, of the dynamic model outlined in Section 4, supplied
 443 as a fully implicit DAE system (see Eq. (25)). Thus, this problem can be
 444 formulated as a general dynamic optimization problem (DOP) over the time
 445 interval $[t_0, t_f]$, with differential algebraic constraints (Biegler, 2010; Biegler

446 et al., 2002) of the form:

$$447 \quad \min_{\boldsymbol{\beta} \in \mathbb{R}^{N_\beta}} \Phi(\boldsymbol{\beta}) \quad (26)$$

448 subj. to Eq. (25)

$$449 \quad \mathbf{y} = \mathbf{g}_y(\mathbf{x}(t), \mathbf{u}(t), \mathbf{w}(t), \boldsymbol{\beta})$$

$$450 \quad \mathbf{x}_{\min} \leq \mathbf{x} \leq \mathbf{x}_{\max}, \quad \mathbf{w}_{\min} \leq \mathbf{w} \leq \mathbf{w}_{\max}$$

$$451 \quad \mathbf{u}_{\min} \leq \mathbf{u} \leq \mathbf{u}_{\max}, \quad \boldsymbol{\beta}_{\min} \leq \boldsymbol{\beta} \leq \boldsymbol{\beta}_{\max}$$

452
 453 in which the response function, \mathbf{g}_y , transforms and selects those state variables
 454 that are experimentally measured, and where $\boldsymbol{\beta}$ is subject to lower and upper
 455 bounds acting as inequality constraints, and estimated by minimizing an ob-
 456 jective function $\Phi(\boldsymbol{\beta})$, penalizing deviations between the observed, $\hat{\mathbf{y}}$, and the
 457 predicted system response, \mathbf{y} . The weighted sum of squared residuals is used to
 458 quantify the estimation, and is defined as:

$$459 \quad \Phi(\boldsymbol{\beta}) = \int_{t_0}^{t_f} [\hat{\mathbf{y}}(t) - \mathbf{y}(t, \mathbf{x}, \mathbf{u}, \boldsymbol{\beta}, \mathbf{w})]^T \mathbf{W} [\hat{\mathbf{y}}(t) - \mathbf{y}(t, \mathbf{x}, \mathbf{u}, \boldsymbol{\beta}, \mathbf{w})] dt \quad (27)$$

460 where the diagonal weight matrix, \mathbf{W} , is introduced to normalize the exper-
 461 imental response, $\hat{\mathbf{y}}(t)$, and penalize a deviation with its associated variance,
 462 $\sigma_{\hat{\mathbf{y}}}^2(t)$.

463 5.2. Optimal Reparameterization of the Arrhenius Equation

464 The mathematical structure of the non-linear Arrhenius equation (see Eq.
 465 (20)) introduces a high correlation between the frequency factor, A_i , and the
 466 activation energy, E_i (Schwaab and Pinto, 2007). This may cause significant
 467 numerical problems when estimating the model parameters and may lead to
 468 the statistical significance of the final parameter estimates being misinterpreted
 469 (Watts, 1994). Schwaab et al. (2008) showed that the explicit introduction
 470 of a reference temperature into the standard Arrhenius equation and proper
 471 selection of the set of reference temperatures, $\mathbf{T}_{\text{ref}} \in \mathbb{R}^{N_i}$, in problems involving
 472 multiple Arrhenius equations can minimize the correlations between parameter

473 estimates, and minimize at the same time the relative standard errors of the
 474 parameter estimates. The two-step parameter estimation procedure proposed
 475 by Schwaab et al. (2008) was for this reason used in this study. This procedure
 476 comprises:

- 477 i) Solution of the DOP (see Eq. (27)) using the initial guesses for \mathbf{T}_{ref} as
 478 the average temperature values in the analyzed experimental range (Vegliò
 479 et al., 2001).
- 480 ii) Minimization of the L_2 -norm of the correlation matrix, $\mathbf{C}(\hat{\boldsymbol{\beta}}, \mathbf{T}_{\text{ref}})$, of pa-
 481 rameter estimates, $\hat{\boldsymbol{\beta}}$:

$$482 \quad \min_{\mathbf{T}_{\text{ref}} \in \mathbb{R}^{N_t}} \|\mathbf{C}(\hat{\boldsymbol{\beta}}, \mathbf{T}_{\text{ref}})\|_2 \quad (28)$$

483 subj. to $\mathbf{T}_{\text{ref},\min} \leq \mathbf{T}_{\text{ref}} \leq \mathbf{T}_{\text{ref},\max}$
 484

- 485 iii) Re-optimization of the DOP with the optimized set of reference tempera-
 486 tures from Eq. (28).

487 The correlation matrix in Eq. (28) is determined from the covariance matrix
 488 of the parameter estimates, $\boldsymbol{\Sigma}(\hat{\boldsymbol{\beta}}, \mathbf{T}_{\text{ref}}) = s^2 [\mathbf{J}(\hat{\boldsymbol{\beta}}, \mathbf{T}_{\text{ref}})^T \mathbf{W} \mathbf{J}(\hat{\boldsymbol{\beta}}, \mathbf{T}_{\text{ref}})]^{-1}$ (Bates
 489 and Watts, 1988; Draper and Smith, 1998):

$$490 \quad \mathbf{C}_{i\ell}(\hat{\boldsymbol{\beta}}, \mathbf{T}_{\text{ref}}) = \frac{\boldsymbol{\Sigma}_{i\ell}(\hat{\boldsymbol{\beta}}, \mathbf{T}_{\text{ref}})}{[\boldsymbol{\Sigma}_{ii}(\hat{\boldsymbol{\beta}}, \mathbf{T}_{\text{ref}}) \boldsymbol{\Sigma}_{\ell\ell}(\hat{\boldsymbol{\beta}}, \mathbf{T}_{\text{ref}})]^{1/2}}, \quad \forall i, \ell \in \{1, 2, \dots, N_\beta\} \quad (29)$$

491 Additionally, it is convenient to update the covariance matrix, $\boldsymbol{\Sigma}(\hat{\boldsymbol{\beta}}, \mathbf{T}_{\text{ref}})$, at
 492 each set \mathbf{T}_{ref} using the explicit method presented by Rimensberger and Rippin
 493 (1986).

494 6. Modeling and Optimization Environment

495 6.1. Discretization Procedure for Limit-cycle System Dynamics

496 The collocation algorithm in the open-source platform JModelica.org (Åkesson
 497 et al., 2010) was used to compute the stable limit-cycle dynamic solution to the
 498 process model (see Eq. (25)). The system dynamics (see Eq. (25a)) were de-
 499 scribed using the Modelica language (The Modelica Association, 2012), which

500 is a high-level language for complex physical models, while the limit-cycle cri-
501 terion (see Eq. (25c)) was implemented in the Modelica extension Optimica
502 (Åkesson, 2008). The user interacts with the various components of JModel-
503 ica.org through the Python scripting language. JModelica.org contains imple-
504 mentations of Legendre–Gauss and Legendre–Gauss–Radau collocation schemes
505 on finite elements. In this study, state and algebraic variables were parameter-
506 ized by Lagrange polynomials of order three and two, respectively, based on
507 Radau collocation points. This gave a non-linear program (NLP) with struc-
508 ture, which was exploited by the solver IPOPT (Wächter and Biegler, 2006).
509 IPOPT uses a sparse primal-dual interior point method to find local optima of
510 large-scale NLPs.

511 The first and second-order derivatives of the constraints functions with re-
512 spect to the NLP variables were computed using the computer algebra system
513 with automatic differentiation (CasADi) (Andersson et al., 2012a) in order to
514 enhance the performance of IPOPT, especially the speed at which the algorithm
515 converged (see e.g. Magnusson and Åkesson (2012)). CasADi is a minimalistic
516 computer algebra system that implements automatic differentiation (AD) in the
517 forward and adjoint modes using a hybrid symbolic/numeric approach. Once
518 a symbolic representation has been created using CasADi, the derivatives that
519 are required are efficiently and conveniently obtained, and sparsity patterns are
520 preserved.

521 *6.2. Sequential Parameter Estimation Methodology*

522 Parameter estimation methods can be classified into two classes: direct
523 search methods and gradient methods (Edgar and Himmelblau, 1988). The
524 model-based methodology described here solved the DOP (see Eq. 26) as fol-
525 lows: First, the parameter space, \mathbb{R}^{N_β} , was sampled by Latin hypercube sam-
526 pling (LHS) (McKay et al., 1979) to obtain suitable input for the heuristic
527 optimization method. Subsequently, the evolution strategy Differential Evolu-
528 tion (DE) *DE/rand-to-best/2/bin* (Price, 1999; Storn and Price, 1997) was used
529 to find the optimal least-squares estimates. Gradient methods generally outper-

- ① Initialization of the DAE system (see Eq. (25a)) subject to the set of process operating parameters $\mathbf{u} = [\dot{Q}_\beta, T, \dot{V}_{VP}]^T$ and $\Pi_\alpha(t_0) := 0, \forall \alpha \in \{A, B\}$. Steady flow conditions with no precursor feed imply that no gas–surface reactions occur and the baseline reactor pressure and carrier gas linear velocity (which depend on the spatial coordinate, $z \in [z_0, z_{\text{end}}]$) are determined through prescribing $\partial\rho(\partial t)^{-1} = \partial v_z(\partial t)^{-1} := 0$ at $t = t_0$. Eq. (25b) is solved by invoking the DAE initialization algorithm in JModelica.org, based on the KINSOL solver from the SUNDIALS suite (Hindmarsh et al., 2005).
- ② Integration of the model of the DAE system (see Eq. (25a)) using the CVODES solver to provide initial guesses for all variables at the collocation points (see Eqs. (24 and 25)). A functional mock-up unit (FMU) was used to convert the model into a system of ordinary differential equations (ODEs), and thereby enabling simulation of the Modelica model in JModelica.org.
- ③ Solution of the NLP using direct collocation and the CasADi interface to IPOPT with the MA27 linear solver to determine the dynamic limit-cycle solution over the time period $[t_0, t_f]$.
- ④ Integration of the DAE system (see Eq. (25a)) and forward sensitivity equations (see Eq. 32), subject to the initial conditions $\theta_\kappa(t_0)$ and $\forall \kappa \in \{A^*, \dots, E^*\} \in \mathbb{R}^{N_\kappa - 1}$ (see Eq. (24)) determined with the collocation method, using the CVODES solver to obtain an accurate approximation of the parameter Jacobian matrix, \mathbf{J} .

Figure 3: The discretization procedure for limit-cycle system dynamics and the sequential parameter estimation method. The final step is invoked only when verifying the solution from the collocation method that precedes it, and when executing the Levenberg–Marquardt algorithm (see Eq. (31)).

530 form direct search methods both in terms of reliability and speed of convergence
 531 (Bard, 1974). Therefore, in order to ensure reliability and to promote conver-
 532 gence of the optimal calibration parameter vector, $\boldsymbol{\beta}^*$, from DE with respect to
 533 the feasible region (the region in which the parameters are linearly independent):

$$534 \quad \{\boldsymbol{\beta}^* \in \mathbb{R}^{N_\beta} : \text{rank}(\mathbf{J}(\boldsymbol{\beta}^*)) = N_\beta \wedge \neg \exists \boldsymbol{\beta} \in \mathbb{R}^{N_\beta}, \Phi(\boldsymbol{\beta}) \leq \Phi(\boldsymbol{\beta}^*)\} \quad (30)$$

535 the Levenberg–Marquardt algorithm (LMA) was used to give the final least-
 536 squares estimates, $\hat{\boldsymbol{\beta}}$. The LMA developed for this modeling framework (An-
 537 dersson et al., 2012b) uses a search direction that is the solution of the set of
 538 linear equations:

$$539 \quad [\mathbf{J}^T \mathbf{W} \mathbf{J} + \lambda \text{diag}(\mathbf{J}^T \mathbf{W} \mathbf{J})] \boldsymbol{\delta}_\beta = \mathbf{J}^T \mathbf{W} [\hat{\mathbf{y}} - \mathbf{y}] \quad (31)$$

540 in which $\mathbf{J} = \partial \mathbf{y}(\partial \boldsymbol{\beta})^{-1}$ is the parameter Jacobian matrix, $\boldsymbol{\delta}_\beta$ denotes an in-
 541 crement to the parameter vector, $\boldsymbol{\beta}$, and the damping factor, λ , controls both

542 the magnitude and direction of β . The solution sensitivity with respect to the
 543 model parameters was used to obtain an accurate approximation of the param-
 544 eter Jacobian matrix by means of the following forward sensitivity equations:

$$545 \quad \frac{d}{dt} \left(\frac{\partial \mathbf{x}}{\partial \beta} \right) = \frac{\partial \mathbf{F}}{\partial \mathbf{x}} \left(\frac{\partial \mathbf{x}}{\partial \beta} \right) + \frac{\partial \mathbf{F}}{\partial \beta}, \quad \frac{\partial \mathbf{x}(t_0)}{\partial \beta} = \frac{\partial \mathbf{x}_0}{\partial \beta} \quad (32)$$

546 obtained by applying the chain rule of differentiation to the original DAEs (see
 547 Eq. (25)). Eq. (32) introduces $(N_x \times N_\beta)$ new differential equations. Fig. 3
 548 describes the collocation procedure used to solve forced periodic systems and
 549 the sequential parameter estimation method.

550 7. Results and Discussion

551 7.1. Accuracy and Reliability of the Parameter Estimates

552 The kinetic parameters (see Eq. (23)) involved in the ALD gas–surface reac-
 553 tions were estimated using the hybrid numerical procedure described in Section
 554 6.2. The associated set of reference temperatures was subsequently optimized
 555 by means of the procedure described in Section 5.2, in order to minimize the
 556 parameter correlations. Table 3 lists the optimal set of parameter estimates, $\hat{\beta}$,
 557 and reference temperatures, $\hat{\mathbf{T}}_{\text{ref}}$, along with corresponding approximate margin
 558 of error, $\varepsilon_{\hat{\beta}_i} = \Sigma_{ii}(\hat{\beta}, \hat{\mathbf{T}}_{\text{ref}})^{1/2} t_{(\varphi; 1-\alpha/2)}$, with a significance level of $\alpha = 5.0 \cdot 10^{-2}$
 559 and $\forall i \in \{1, 2, \dots, N_\beta\}$.

560 Fig. 4 shows representative results for these quantities for the kinetic pa-
 561 rameters β_i and $i \in \{1, 2, 7, 8\}$ associated with Reactions (R2a and R2c) as
 562 functions of the reference temperatures $T_{\text{ref},1}^{\text{eq}}$ and $T_{\text{ref},3}^{\text{fwd}}$. These results show the
 563 behavior of the relative errors and the correlations between the parameter esti-
 564 mates. Figs. 4a and 4b show that the correlation between the parameters ΔE_1^{eq}
 565 and E_3^{fwd} , and the relative errors of these, were independent of the reference
 566 temperature, as Schwaab and Pinto (2007) have shown previously. Further, the
 567 relative error of parameter $K_{T_{\text{ref},1}}^{\text{eq}}$ depended only on $T_{\text{ref},1}^{\text{eq}}$, while the relative
 568 error of parameter $k_{T_{\text{ref},3}}^{\text{fwd}}$ depended only on $T_{\text{ref},3}^{\text{fwd}}$. This is evident from Fig.
 569 4b, from which it is also clear that the relative errors attained minimum values

Table 3: Regression analysis of the least-squares estimates, $\hat{\beta}$, of the parameters of Reactions (R2 and R3). The normalized margin of error, $\bar{\varepsilon}_{\hat{\beta}}$, was determined at a significance level of $\alpha = 5.0 \cdot 10^{-2}$. The specific reaction rate coefficients $K_{T_{\text{ref}},i}^{\text{eq}}$, $k_{T_{\text{ref}},i}^{\text{fwd}}$, and $k_{T_{\text{ref}},i}^{\text{rev}}$ are defined at the associated optimal reference temperature $T_{\text{ref},i}^{\text{eq}}$, $T_{\text{ref},i}^{\text{fwd}}$ and $T_{\text{ref},i}^{\text{rev}}$, respectively.

Elementary surface reaction, i	i	Parameter, β	Parameter units	Parameter estimates, $\hat{\beta}$	Margin of error, $\bar{\varepsilon}_{\hat{\beta}}$ (%)
Reaction (R2a)	1	$K_{T_{\text{ref},1}}^{\text{eq}}$	Pa^{-1}	$4.97 \cdot 10^{-2}$	6.96
$A * + A \xrightleftharpoons{K_1^{\text{eq}}} B *$	2	ΔE_1^{eq}	J mol^{-1}	$4.48 \cdot 10^4$	5.98
		$T_{\text{ref},1}^{\text{eq}}$	K	$4.23 \cdot 10^2$	
Reaction (R2b)	3	$k_{T_{\text{ref},2}}^{\text{fwd}}$	s^{-1}	$1.61 \cdot 10^2$	1.82
$B * \xrightleftharpoons[k_2^{\text{rev}}]{k_2^{\text{fwd}}} C *$	4	E_2^{fwd}	J mol^{-1}	$4.22 \cdot 10^4$	1.75
		$T_{\text{ref},2}^{\text{fwd}}$	K	$4.10 \cdot 10^2$	
	5	$k_{T_{\text{ref},2}}^{\text{rev}}$	s^{-1}	$5.14 \cdot 10^2$	2.12
	6	E_2^{rev}	J mol^{-1}	$9.51 \cdot 10^4$	6.01
		$T_{\text{ref},2}^{\text{rev}}$	K	$4.35 \cdot 10^2$	
Reaction (R2c)	7	$k_{T_{\text{ref},3}}^{\text{fwd}}$	s^{-1}	$3.72 \cdot 10^1$	5.34
$C * \xrightarrow{k_3^{\text{fwd}}} D * + C$	8	E_3^{fwd}	J mol^{-1}	$1.53 \cdot 10^4$	9.55
		$T_{\text{ref},3}^{\text{fwd}}$	K	$4.43 \cdot 10^2$	
Reaction (R3a)	9	$K_{T_{\text{ref},4}}^{\text{eq}}$	Pa^{-1}	$7.45 \cdot 10^{-2}$	1.60
$D * + B \xrightleftharpoons{K_4^{\text{eq}}} E *$	10	ΔE_4^{eq}	J mol^{-1}	$4.11 \cdot 10^4$	9.26
		$T_{\text{ref},4}^{\text{eq}}$	K	$4.24 \cdot 10^2$	
Reaction (R3b)	11	$k_{T_{\text{ref},5}}^{\text{fwd}}$	s^{-1}	$1.42 \cdot 10^2$	2.29
$E * \xrightleftharpoons[k_5^{\text{rev}}]{k_5^{\text{fwd}}} F *$	12	E_5^{fwd}	J mol^{-1}	$4.13 \cdot 10^4$	8.77
		$T_{\text{ref},5}^{\text{fwd}}$	K	$4.04 \cdot 10^2$	
	13	$k_{T_{\text{ref},5}}^{\text{rev}}$	s^{-1}	$3.76 \cdot 10^2$	1.79
	14	E_5^{rev}	J mol^{-1}	$9.74 \cdot 10^4$	1.65
		$T_{\text{ref},5}^{\text{rev}}$	K	$4.39 \cdot 10^2$	
Reaction (R3c)	15	$k_{T_{\text{ref},6}}^{\text{fwd}}$	s^{-1}	$4.53 \cdot 10^1$	1.56
$F * \xrightarrow{k_6^{\text{fwd}}} A * + C$	16	E_6^{fwd}	J mol^{-1}	$2.97 \cdot 10^4$	4.28
		$T_{\text{ref},6}^{\text{fwd}}$	K	$4.40 \cdot 10^2$	

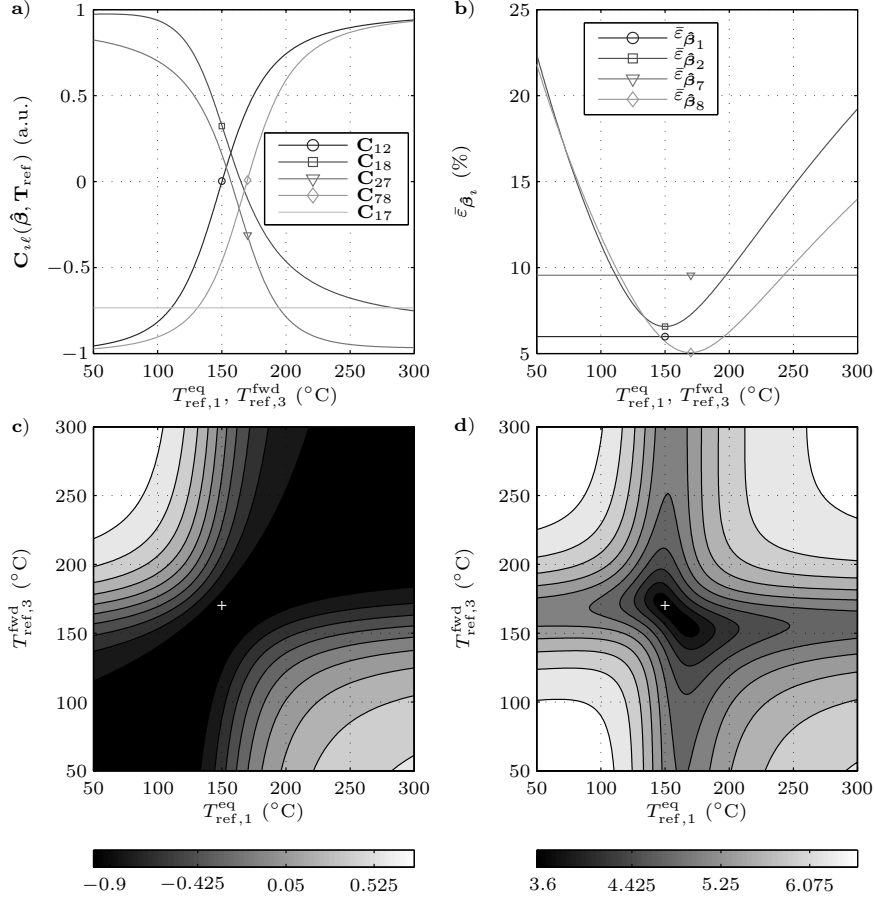

Figure 4: Representative results of the two-step procedure by which parameters were estimated, to be used for optimal reparameterization of the Arrhenius equation (Schwaab et al., 2008). a) $C_{i\ell}(\hat{\beta}, \mathbf{T}_{\text{ref}})$ and $i \neq \ell$ as functions of $\mathbf{T}_{\text{ref},i}$ and $i \in \{1, 3\}$. b) Relative errors, $\bar{\epsilon}_{\beta_i}$, as functions of $\mathbf{T}_{\text{ref},i}$. c) Correlation between $K_{T_{\text{ref},1}}^{\text{eq}}$ and $k_{T_{\text{ref},3}}^{\text{fwd}}$, C_{17} , as a function of $\mathbf{T}_{\text{ref},i}$. d) $\|C(\hat{\beta}, \mathbf{T}_{\text{ref}})\|_2$ as a function of $\mathbf{T}_{\text{ref},i}$. (+) Optimal set of reference temperatures $\hat{\mathbf{T}}_{\text{ref},i}$ and $i \in \{1, 3\}$.

570 around certain values of $\mathbf{T}_{\text{ref},i}$ and $i \in \{1, 3\}$. Fig. 4a shows also that the corre-
571 lation coefficients associated with $K_{T_{\text{ref},1}}^{\text{eq}}$, i.e. C_{12} and C_{18} , depended only on
572 $T_{\text{ref},1}^{\text{eq}}$, whereas the correlation coefficients associated with $k_{T_{\text{ref},3}}^{\text{fwd}}$, i.e. C_{27} and
573 C_{78} , depend only on $T_{\text{ref},3}^{\text{fwd}}$. It is evident that these correlations can be made

574 equal to zero: \mathbf{C}_{12} and \mathbf{C}_{27} , in particular, are approximately zero for the opti-
575 mal values of $\mathbf{T}_{\text{ref},i}$ and $i \in \{1, 3\}$. Unfortunately, the optimal reference values
576 do not lead to zero values of the correlations for the remaining coefficients \mathbf{C}_{18}
577 and \mathbf{C}_{27} in Fig. 4a. Finally, the correlation between $K_{T_{\text{ref},1}}^{\text{eq}}$ and $k_{T_{\text{ref},3}}^{\text{fwd}}$, \mathbf{C}_{17}
578 depended in a complex manner on both $T_{\text{ref},1}^{\text{eq}}$ and $T_{\text{ref},3}^{\text{fwd}}$ (Fig. 4c). In addition
579 \mathbf{C}_{17} became very high at the optimal reference temperatures that minimize the
580 L₂-norm of $\mathbf{C}(\hat{\boldsymbol{\beta}}, \mathbf{T}_{\text{ref}})$ (see Eq. (28)) as depicted in Fig. 4d, and this allows
581 other parameter correlations to be eliminated. Thus, it is clear that it is not
582 possible to eliminate all correlations simultaneously.

583 Analysis of the confidence intervals and regions provides a more rigorous
584 statistical evaluation of the parameter estimates. A statement with a high
585 confidence suggests either that a parameter estimate cannot be discriminated
586 from another using the experimental design being considered, or that there is a
587 high uncertainty in the precision associated with this parameter (in other words:
588 the model cannot distinguish between phenomenon in the system (Bard, 1974;
589 Bates and Watts, 1988)). For this purpose, the likelihood $100(1 - \alpha)\%$ joint
590 confidence region is defined for all values of $\boldsymbol{\beta}$ such that:

$$591 \quad \{\boldsymbol{\beta} : \Phi(\boldsymbol{\beta}) - \Phi(\hat{\boldsymbol{\beta}}) \leq s^2 N_{\beta} F_{(N_{\beta}, \varphi; \alpha)}\} \quad (33)$$

592 in which $F_{(N_{\beta}, \varphi; \alpha)}$ is the upper α quantile of Fisher's F -distribution. Fig. 5
593 shows the likelihood $100(1 - \alpha)\%$ joint confidence regions, with a significance
594 level of $\alpha = 5 \cdot 10^{-2}$. The results are shown for pairs of parameters β_i and $\forall i \in$
595 $\{1, 2, 7, 8\}$ described by sampling the parameter space, $\boldsymbol{\beta} \in \mathbb{R}^{N_{\beta}}$, with LHS. It
596 is evident that the significant reduction in parameter correlation observed in 4a
597 also improved the elliptical representation of the confidence regions, as discussed
598 by Bates and Watts (1988). Moreover, it is noteworthy that the relative errors of
599 the parameters ΔE_1^{eq} and E_3^{fwd} were independent of the reference temperatures
600 adopted, Fig. 4b, and that the apparent reduction in the relative errors of these
601 parameters were governed instead by the reduction in $\Phi(\hat{\boldsymbol{\beta}})$ (see Eq. (27)). This
602 reduction occurred due to enhanced convergence of the LMA when the DOP
603 (see Eq. (26)) was re-optimized with the optimal set of reference temperatures,

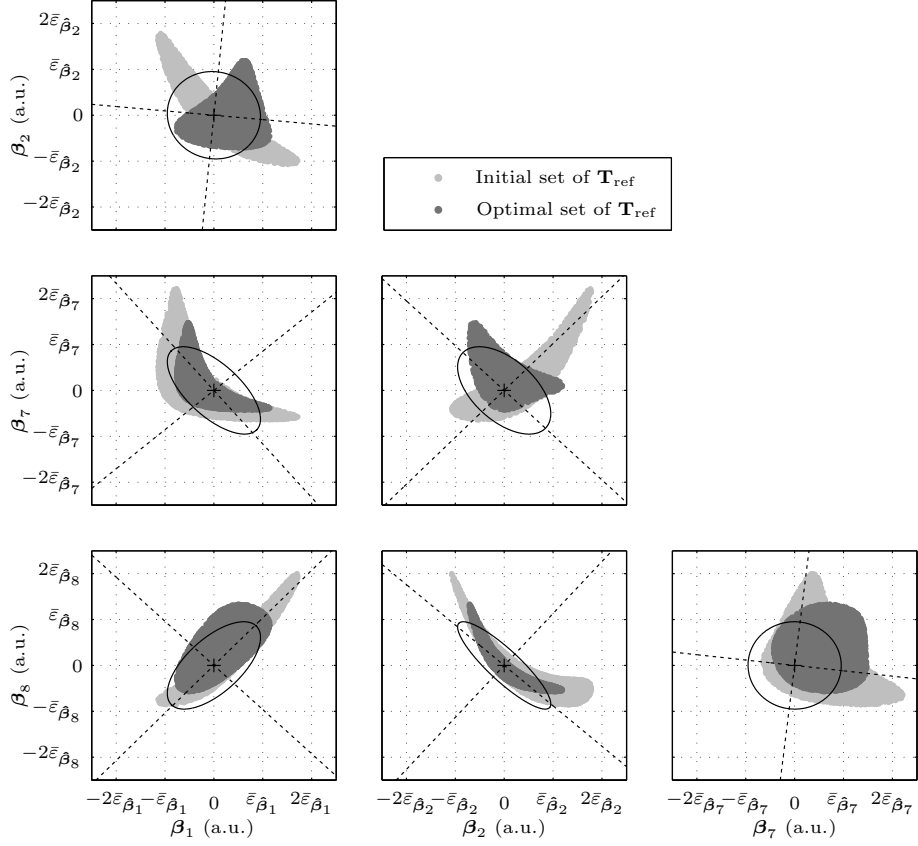

Figure 5: Nominal 95% likelihood confidence region (see Eq. (33)) for pairs of normalized and centered parameters β_i and $\forall i \in \{1, 2, 7, 8\}$. The $(-)$ symbol shows the approximate joint 95% confidence region, while $(+)$ shows the normalized and centered least-squares estimates, $\hat{\beta}_i$. $(--)$ shows the principal axes given by the eigenvectors of $\Sigma(\hat{\beta}, \hat{\mathbf{T}}_{\text{ref}})$.

604 $\hat{\mathbf{T}}_{\text{ref}}$.

605 7.2. Accuracy and Reliability of the Predicted Model Response

606 The QCM trajectory for all $N_{\Delta t}$ cycles was fractionated with assigned t_0 at
 607 the start of the $\text{Zn}(\text{C}_2\text{H}_5)_2$ precursor pulse in Fig. 2, which is the most convenient
 608 representation when determining $\hat{\nu}$ from Eq. (3). When solving the DOP

609 (see Eq. (26)), however, t_0 was assigned to the center of the carrier gas purge
 610 that followed the H₂O precursor pulse, such that it was possible to simulate
 611 a smooth rectangular function, $\Pi_\alpha(t, \Delta t_\alpha)$, that was composed of superposed
 612 logistic functions. This procedure redistributed the standard deviations of each
 613 temporal sample, while the extracted quantities $\hat{\nu}$ and $d\Delta\hat{m}_q|_{\Delta t}(dN_{\Delta t})^{-1}$ listed
 614 in Table 1 remained constant. Additionally, the collocation method (see Section
 615 6.1) used to compute the limit-cycle solution was solved for 50 finite elements
 616 in the experimental time horizon $[0, \Delta t_j]$ and $\forall j \in \{1, 2, \dots, N_j\}$, with three
 617 Radau collocation points in each element. Section 7.3 presents a comparison
 618 between the limit-cycle solutions determined with the collocation method and
 619 those determined by the verification simulation (see Fig. 3).

620 Fig. 6 presents the accumulated mass per unit QCM sensor area, $\langle m_q \rangle$, (see
 621 Eq. (18)) for the least-squares estimates listed in Table 3 and the associated
 622 $100(1-\alpha)\%$ confidence bands, for a representative set of calibration experiments.
 623 The figure verifies the precision of the simulated model response. The graphic
 624 representation for the experimental calibration datasets $j \in \{3, 8, 9, 14, 10\}$ (cor-
 625 responding to one set for each temperature studied in the range $T \in [100, 200]$
 626 ($^{\circ}\text{C}$) (see Table 1)) shows that the model output agrees well with the exper-
 627 imental data. The confidence bandwidth is moderately narrow and replicates
 628 the temporal dependency of the model response. Thus, the accuracy and pre-
 629 dictability of the transient mass gain, $\langle m_q \rangle$, can be determined by analyzing the
 630 bandwidth and shape of the approximate confidence bands. The effect of the
 631 uncertainty on the precision of the parameter estimates can also be evaluated
 632 in this way. However, the poorest fit of $\langle m_q \rangle$ in the experimental time horizon
 633 occurred for the initial increase in mass at the leading edge of the Zn(C₂H₅)₂
 634 precursor pulse. It is noteworthy that this temporal region was associated with
 635 the highest experimental uncertainty, and – since the variance $\sigma_{\langle \Delta \hat{m}_q \rangle}^2$ of each
 636 temporal sampling point is balanced in the time-variant weight matrix, \mathbf{W} –
 637 the error that this set of sampling points contributed to the weighted sum of
 638 squared residuals (see Eq. (27)) was considerably reduced. Finally, it is also
 639 noteworthy that the increase in $\langle m_q \rangle$ shortly before the α th precursor pulse on-

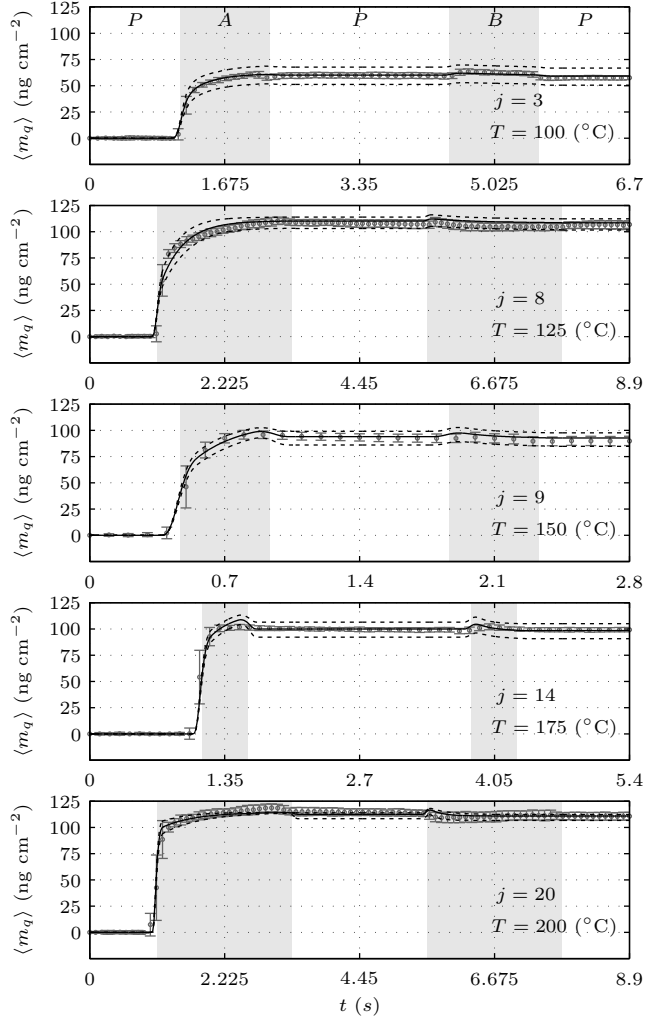

Figure 6: Transient mass gain per unit area of exposed surface of QCM sensor for a single-pulse sequence horizon $[0, \Delta t_j]$ and the calibration set $j \in \{3, 8, 9, 14, 10\}$ listed in Table 1. The $(-)$ symbol shows the integral mean value of the QCM mass gain, $\langle m_q \rangle$, (see Eq. 18), while $(--)$ shows the associated uncertainty bands for the expected response determined by the parameter bounds that were specified according to the 95% joint confidence region governed by Eq. (33). (o) shows the *in situ* QCM mean mass gain, $\langle \Delta \hat{m}_q \rangle$, while the error bars show the associated confidence intervals, $\sigma_{\langle \Delta \hat{m}_q \rangle}$. The shaded rectangles indicate the precursor pulse interval endpoints.

640 set arises from the tailing of the smooth rectangular function, $\Pi_\alpha(t, \Delta t_\alpha)$, used
641 to model the non-overlapping precursor injections.

642 The transient mass gain trajectory determined from Eq. (18) can be mech-
643 anistically interpreted by means of the chemical composition of the growth sur-
644 face, i.e. the fractions of the surface that are covered by precursor adduct
645 species, by adduct species in their transition state, and the chemisorbed species
646 that are left by the ligand elimination reactions (see Reactions (R2 and R3)).
647 Thus, the trajectory of the transient mass gain during the $\text{Zn}(\text{C}_2\text{H}_5)_2$ precursor
648 exposure arises from the complex interdependence between the gas–surface pre-
649 cursor adsorption equilibrium (Reaction (R2a)), the adsorbed precursor adduct
650 and transition state equilibrium (Reaction (R2b)), and the irreversible ligand
651 elimination surface reaction (Reaction (R2c)). Specifically, the net contribution
652 from Reaction (R2a) to Eq. (18) is the degree of saturation of the fractional
653 surface coverage of hydroxyl groups, while the accumulated mass is unchanged
654 as Reaction (R2b) proceeds. The contribution from Reaction (R2c), in contrast,
655 arises from the production of $\langle \hat{\nu} \rangle$ C_2H_6 molecules, which subsequently desorb
656 to the gas-phase.

657 Reversible chemisorbed surface species θ_κ and $\kappa \in \{B^*, C^*\}$ are desorbed in
658 particular at the trailing edge of the $\text{Zn}(\text{C}_2\text{H}_5)_2$ precursor exposure, as $p_A \rightarrow$
659 0 in Eq. (21e), which can be seen most clearly for $j = \{9, 14\}$ in Fig. 6.
660 Desorption is more pronounced at elevated temperatures, since the reaction rate
661 coefficient k_2^{rev} in Eq. (22a) is higher. The $\langle m_q \rangle$ trajectory is approximately
662 constant during the subsequent carrier gas purge, which implies that negligible
663 desorption takes place, and thus reversible chemisorbed species are desorbed
664 almost instantaneously as $p_A \rightarrow 0$ at the trailing edge of the precursor exposure.
665 However, it is noteworthy that the DAE system (see Eq. (21)) that governs the
666 fractional surface coverage species dynamics for Reactions (R2 and R3) can
667 reproduce desorption phenomena during the entire carrier gas purge period, as
668 long as the surface species $\kappa \in \{B^*, C^*\}$ are present at the growth surface.

669 Furthermore, the physicochemical phenomena that govern the appearance
670 of the $\langle m_q \rangle$ trajectory during the subsequent H_2O precursor exposure are anal-

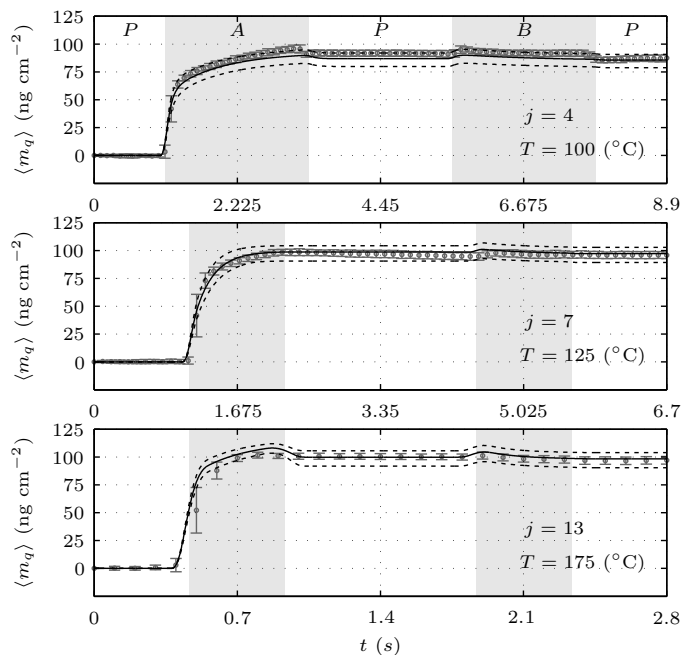

Figure 7: Transient mass gain per unit exposed surface QCM sensor area for a single-pulse sequence horizon $[0, \Delta t_j]$ and the validation set $j \in \{4, 7, 13\}$ listed in Table 1. The $(-)$ symbol shows the integral mean value of the QCM mass gain, $\langle m_q \rangle$, (see Eq. 18), while $(- -)$ shows the associated uncertainty bands for the expected response determined by the parameter bounds that were specified according to the 95% joint confidence region governed by Eq. (33). (\circ) shows the *in situ* QCM mean mass gain, $\langle \Delta \hat{m}_q \rangle$, while the error bars show the associated confidence intervals, $\sigma_{\langle \Delta \hat{m}_q \rangle}$. The shaded rectangles indicate the precursor pulse interval endpoints.

671 ogous to those of the $\text{Zn}(\text{C}_2\text{H}_5)_2$ precursor exposure, although the molecular
672 masses of the reagents differ. Hence, the mass increases at the leading edge of
673 the H_2O pulse, which arises from the adsorption and formation of the precursor
674 adduct species and its transition state ($\kappa \in \{E^*, F^*\}$). The increase in mass
675 takes place before the ligand elimination reaction (Reaction (R3c)) converts the
676 transition states F^* , and before they have passed through the reverse reaction
677 (Reaction R3b) to their corresponding adduct state E^* (and subsequently des-
678 orbled from the growth surface by means of Reaction (R3a)). The increase in

679 mass is most pronounced at low temperatures (as for $j = 3$ in Fig. 6) and which
 680 arises from the aforementioned temperature dependence of the elementary sur-
 681 face reaction kinetics. However, the difference in molecular mass between the
 682 initial and terminal surface species in Reaction (R3), denoted ΔM_B in Eq. (3),
 683 means that the net contribution to Eq. (18) from this half-reaction is less than
 684 zero for values of $\nu < 2 - M_{\text{H}_2\text{O}}(M_{\text{C}_2\text{H}_6})^{-1} \approx 1.40$. Obviously, this is the case
 685 for the $\langle \hat{\nu} \rangle$ determined in Section 2.4.

686 The ultimate test of the model is to compare it with the validation set.
 687 The region of validity is the union between the calibration region and the region
 688 covered by the validation experiments (Brereton, 2003). Fig. 7 shows the model
 689 response for the experimental validation dataset with $j \in \{4, 7, 13\}$ (see Table
 690 1). The trajectory of the transient mass gain, $\langle m_q \rangle$, shows that the performance
 691 of the model is satisfactory, with narrow confidence bands and conformal growth
 692 per limit cycle, $d\langle m_q \rangle|_{\Delta t} (dN_{\Delta t})^{-1}$. The predictions of the model are assessed
 693 in more detail below to determine the impact of the precursor pulse duration
 694 and deposition temperature on film growth per limit cycle, and to distinguish
 695 between ALD in saturating and in non-saturating film growth conditions.

696 7.2.1. Effect of Deposition Temperature on Film Growth per Limit Cycle

697 Fig. 8 shows the model predicted and experimentally observed effects of de-
 698 position temperature, T , on the film growth rate per limit cycle. Non-saturating
 699 growth is obtained for the precursor exposure period $\widetilde{\Delta t}_\alpha = 0.40$ (s) in the en-
 700 tire temperature range $[75, 275]$ ($^\circ\text{C}$). Additionally, the rate of film growth per
 701 limit cycle does not show a self-limiting growth region under these conditions,
 702 as $d\langle m_q \rangle|_{\Delta t} (dN_{\Delta t})^{-1}$ falls significantly for $T < 175$ ($^\circ\text{C}$) and for $T > 175$
 703 ($^\circ\text{C}$). The initially low MGPC values in the low-temperature region ($T < 175$
 704 ($^\circ\text{C}$)) arises from the activation barrier of the forward elementary reactions
 705 $i \in \{2, 3, 5, 6\}$ (see Reactions (R2 and R3)) which make it thermodynamically
 706 more favorable for adsorbed precursors to desorb than to proceed through the
 707 surface ligand-elimination reactions. The activation energies of these reactions
 708 are more easily overcome as the temperature increases, which promotes the equi-

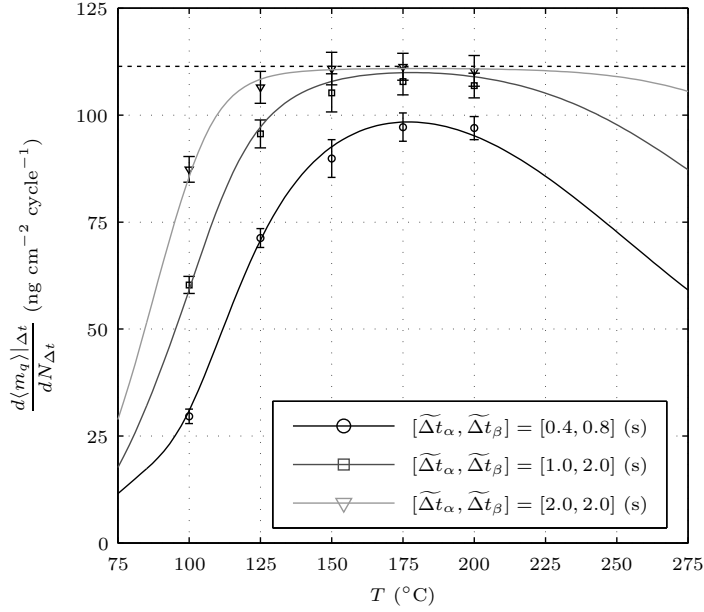

Figure 8: The effect of deposition temperature in the range $T \in [75, 275]$ ($^{\circ}\text{C}$) on the mass gain per limit cycle, $d\langle m_q \rangle |_{\Delta t} (dN_{\Delta t})^{-1}$, at three levels of precursor exposure in the range $\widetilde{\Delta t}_{\alpha} \in [0.4, 2.0]$ (s) with $\alpha \in \{A, B\}$. The symbols (o, \square , ∇) show the estimated MGPC, $d\Delta\hat{m}_q |_{\Delta t} (dN_{\Delta t})^{-1}$, scaled with the *ex situ* XRR reference thickness, while the error bars show the associated confidence intervals, $\sigma_{\frac{d\Delta\hat{m}_q |_{\Delta t}}{dN_{\Delta t}}}$, for the dataset $j \notin \{2, 6, 10, 14, 18\}$ in Table 1. (---) shows the maximum MGPC, $\max d\Delta\hat{m}_q |_{\Delta t} (dN_{\Delta t})^{-1}$.

709 librium surface coverage of intermediate complexes and, ultimately, the concen-
 710 tration of surface species onto which the precursors can adsorb and cause in this
 711 way the increase in growth rate.

712 In contrast, the activation energy of the reversed elementary reactions $i \in$
 713 $\{2, 5\}$ is overcome in the high temperature region ($T > 175$ ($^{\circ}\text{C}$)) under these
 714 non-saturating conditions, which makes desorption more favorable. This lowers
 715 the rate of conversion of the fractional surface coverage of $\kappa \in \{A^*, D^*\}$ per limit
 716 cycle. This implies that the significant increase in the reaction rate coefficients
 717 k_2^{rev} and k_5^{rev} (see Eqs. (22a and 22b)), governs to a high extent the overall
 718 MGPC at elevated temperatures. Additionally, it is noteworthy that the gas-

719 surface equilibrium reactions $i \in \{1, 4\}$ also proceed faster in both directions
720 (see Eqs. (21e and 21f)).

721 Fig. 8 shows that MGPC approaches the maximum growth per limit cycle
722 for the precursor exposure period $\widetilde{\Delta t}_\alpha = 1.0$ (s). This corresponds to surface
723 saturation and is associated with the maximum surface concentrations, Λ , (see
724 Section 2.4). The observed flat profile that encloses the maximum deposition
725 rate indicates that a self-limiting growth region appears progressively under
726 these conditions. As expected, this ideal self-limiting growth region widens for
727 longer periods of precursor exposure, while it remains limited by the aforemen-
728 tioned thermodynamics of the precursor half-cycle reactions at low and high
729 temperatures.

730 7.2.2. Effect of Precursor Exposure Duration on Film Growth per Limit Cycle

731 Fig. 9 shows the effect of precursor pulse duration, Δt_α and $\alpha \in \{A, B\}$, on
732 the film growth rate per limit cycle, $d\langle m_q \rangle|_{\Delta t} (dN_{\Delta t})^{-1}$. The exposure periods of
733 the two precursors were set to be equal and to vary in parallel in the range $\Delta t_\alpha \in$
734 $(0, 5]$ (s), while the carrier gas purge period was maintained at $\Delta t_\beta := 2\Delta t_\alpha$ (s).
735 It is evident that $d\langle m_q \rangle|_{\Delta t} (dN_{\Delta t})^{-1}$ approaches the limiting value corresponding
736 to surface saturation asymptotically, as expected for the self-terminating ALD
737 reaction kinetics. This behavior is independent of the deposition temperature.
738 Figs. 8 and 9 make it also clear that the model predictions agree well with the
739 experimental data, and successfully distinguish growth per limit cycle between
740 saturating and non-saturating conditions. The predictive power of the model
741 is crucial in this context, especially since it is necessary to keep the individual
742 precursor doses to a minimum while maintaining sufficiently high exposure, at
743 the lower bound defined by non-saturating conditions (Travis and Adomaitis,
744 2013b), in order to optimize commercial reactor systems. This is even more
745 critical in the high-throughput spatial ALD systems that are under development
746 for use in roll-to-roll and other large-substrate applications.

747 Finally, it is important to note that $d\langle m_q \rangle|_{\Delta t} (dN_{\Delta t})^{-1}$ is ultimately gov-
748 erned by the half-cycle average exposure dose, $\langle \delta_\alpha \rangle$, for the α th precursor. The

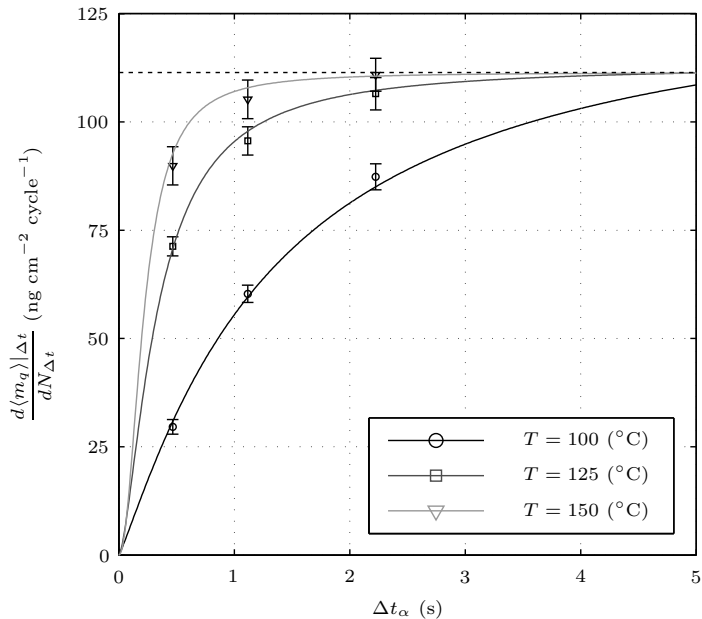

Figure 9: The effect of precursor pulse duration, Δt_α and $\forall \alpha \in \{A, B\}$ set to be equal and to vary in parallel in the range $\Delta t_\alpha \in (0.0, 5.0]$ (s), on the mass gain per limit cycle, $d\langle m_q \rangle|_{\Delta t} (dN_{\Delta t})^{-1}$, sampled at $T \in \{100, 125, 150\}$ ($^\circ\text{C}$) and with $\Delta t_\beta := 2\Delta t_\alpha$. The symbols (\circ, \square, ∇) show the estimated MGPC, $d\Delta\hat{m}_q|_{\Delta t} (dN_{\Delta t})^{-1}$, scaled with the *ex situ* XRR reference thickness, while the error bars show the associated confidence intervals, $\sigma \frac{d\Delta\hat{m}_q|_{\Delta t}}{dN_{\Delta t}}$, for the dataset $j \in \{1, 3, 4, 5, 7, 8, 9, 11, 12\}$ in Table 1. (--) shows the maximum MGPC, $\max d\Delta\hat{m}_q|_{\Delta t} (dN_{\Delta t})^{-1}$.

749 exposure of the growth surface is characterized by the time-dependent, local,
 750 precursor partial pressure during the exposure period and during a portion of
 751 each purge period:

$$752 \quad \langle \delta_\alpha \rangle = \frac{1}{(\zeta_{\text{end}} - \zeta_0)} \int_{t_0}^{t_f} \int_{\zeta_0}^{\zeta_{\text{end}}} p_\alpha d\zeta dt \quad (34)$$

753 in which $t_f = \Delta t_\alpha + \Delta t_\beta$. Thus, it is expected that an increase in the precursor
 754 mass flow, \dot{Q}_α , will yield a higher partial pressure, p_α , and consequently enhance
 755 the deposition rate, $d\langle m_q \rangle|_{\Delta t} (dN_{\Delta t})^{-1}$. This will achieve saturation growth
 756 conditions at exposure times, Δt_α , that are lower than those presented Fig. 9.

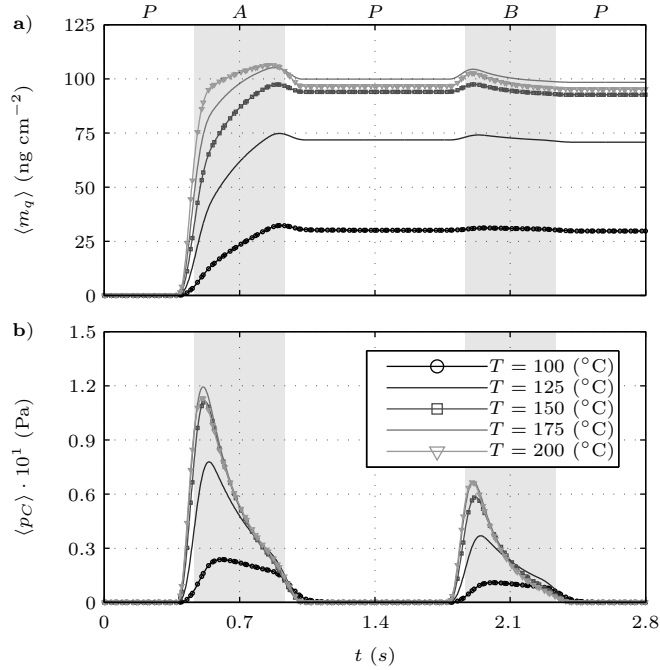

Figure 10: Model-generated transient mass gain per unit of exposed QCM sensor area, $\langle m_q \rangle$, and the spatial integral mean value of p_C in $z \in [z_0, z_{\text{end}}]$ (m), resolved at a single pulse sequence $[\widetilde{\Delta t}_\alpha, \widetilde{\Delta t}_\beta] = [0.4, 0.8]$ (s) in the temperature range $T \in [100, 200]$ ($^\circ\text{C}$). (\circ, \square, ∇) show the collocation based trajectories at the Radau collocation point locations, while (—) shows the simulated trajectories. The shaded rectangles indicate the precursor pulse interval endpoints.

757 An extensive investigation of the precursor exposure dose is beyond the scope
 758 of the present study, and the reader is referred to Holmqvist et al. (2013a,b),
 759 for example, for more details.

760 7.3. Time Evolution of the Stable Limit-Cycle Solutions

761 This section describes several aspects of the dynamic ALD limit-cycle so-
 762 lution. The limit-cycle solutions shown in Figs. 10–13 present the same case
 763 study with an assigned pulse sequence $[\widetilde{\Delta t}_\alpha, \widetilde{\Delta t}_\beta] = [0.4, 0.8]$ (s) and temper-
 764 ature range $T \in [100, 200]$ ($^\circ\text{C}$). This corresponds to the operating conditions
 765 of the experimental datasets $j \in \{1, 5, 9, 13, 17\}$ listed in Table 1. Figs. 10–

766 13 present also the results from the collocation method, and the figures thus
 767 compare these results with those obtained from the model integration of the
 768 DAE system with the CVODES solver (see Fig. 3). The results are practically
 769 identical. The collocation method used corresponds to a Radau solver with a
 770 fixed step size, while the solver used in the verification simulation uses a vari-
 771 able step size formula with backward differentiation and error control. Thus,
 772 the solution found by the CVODES solver fulfils the model equations, at least
 773 to the specified tolerances.

774 Fig. 10a confirms the mechanistic interpretation presented in Section 7.2,
 775 in that the slope of the trajectory of mass gain, $\langle m_q \rangle$, generated by the model
 776 at the leading edges of both precursor exposure periods becomes steeper as the
 777 temperature increases. Moreover, the elementary precursor adduct desorption
 778 reactions, $i \in \{2, 5\}$, and the precursor gas-surface equilibrium reactions, $i \in$
 779 $\{1, 4\}$, proceed faster in the high-temperature region, and these reactions thus
 780 demonstrate more pronounced desorption effects. They ultimately govern the
 781 overall decrease in mass gain per limit cycle. It is noteworthy that the terminal
 782 value of the mass gain trajectory, $\langle m_q \rangle(t_f)$, for $T = 200$ ($^{\circ}\text{C}$) falls below that
 783 of $T = 175$ ($^{\circ}\text{C}$) (which can be compared with the temperature dependence of
 784 $d\langle m_q \rangle|_{\Delta t} (dN_{\Delta t})^{-1}$ in Fig. 8).

785 Fig. 10b shows a complementary method for analyzing the dynamics of Re-
 786 actions (R2 and R3). This method considers the trajectory of the integral mean
 787 value of the gas-phase composition of C_2H_6 on the spatial domain, $z \in [z_0, z_{\text{end}}]$.
 788 This is the most convenient method for elucidating the ligand-elimination re-
 789 actions, $i \in \{3, 6\}$, since the production of C_2H_6 is governed exclusively by the
 790 continuation of these irreversible reactions. This method enables the number of
 791 hydroxyl groups that react with each $\text{Zn}(\text{C}_2\text{H}_5)_2$ precursor molecule, ν , to be
 792 estimated by temporal and spatial integration of the reaction byproduct that
 793 is released during the $\text{Zn}(\text{C}_2\text{H}_5)_2$ precursor half-reaction $[t_0, t_1]$ and the entire

794 time horizon, $[t_0, t_f]$. The number of hydroxyl groups is thus given by:

$$795 \quad \nu = \nu_L \int_{t_0}^{t_1} \int_{z_0}^{z_{\text{end}}} p_C dz dt \left(\int_{t_0}^{t_f} \int_{z_0}^{z_{\text{end}}} p_C dz dt \right)^{-1} \quad (35)$$

796 in which ν_L is the total number of ligands of the adsorptive organometallic
 797 precursor, and $t_1 = \Delta t_A + \Delta t_P$ is the upper limit for the nominator temporal
 798 integral. Finally, it is noteworthy that the values determined from Eq. (35)
 799 and the $\langle p_C \rangle$ trajectories depicted in Fig. 10b, correspond to the value of $\langle \dot{\nu} \rangle$
 800 estimated from Eq. (3) and the *in situ* QCM mean mass gain, $\langle \Delta \hat{m}_q \rangle$ (see
 801 Section 2.4).

802 Computing the limit-cycle solution over the time horizon $[t_0, t_f]$ requires that
 803 the terminal composition of the fractional surface coverage species, $\theta_\kappa(t_f)$ and
 804 $\forall \kappa \in \{A^*, \dots, F^*\}$, returns to its initial composition, $\theta_\kappa(t_0)$, (see Eq. (24a)).
 805 The forced-period system dynamics are described by the DAE system in Eq.
 806 (25), which is subject to the surface state initial conditions (see Eq. (25b)) and
 807 terminal constraints (see Eq. (25c)). This implies that an unambiguous method
 808 to numerically compute limit-cycle ALD dynamic solutions is essential for the
 809 accuracy, reliability and reproducibility of the solution of such DAE systems.
 810 Fig. 11 presents a representative limit-cycle solution computed using the collo-
 811 cation method (see Section 6.1), where the fractional surface state composition
 812 is depicted as a function of time over the entire horizon $[t_0, t_f]$. Under these
 813 conditions, the growth surface approaches a fully saturated state during both
 814 of the precursor exposures. The surface state limit-cycle dynamic model (see
 815 Eq. (21)) states that saturating ALD conditions per limit-cycle are obtained
 816 if the fractional surface coverage $\theta_{A^*}(t_0) = \theta_{A^*}(t_f) := 1.0$, and consequently
 817 $\theta_\kappa(t_0) = \theta_\kappa(t_f) := 0.0$ and $\forall \kappa \notin A^*$, according to Eq. (24b). Thus, an impor-
 818 tant consequence of the limit-cycle solutions depicted in Fig. 11 is that they
 819 enable to mechanistically quantify the difference between the saturating ALD
 820 and non-saturating film growth conditions previously observed in Figs. 8 and 9
 821 by means of the underlying surface-state limit-cycle dynamics.

822 Fig. 11 shows that $\theta_{A^*} \rightarrow 0$ during the $\text{Zn}(\text{C}_2\text{H}_5)_2$ exposure as the growth

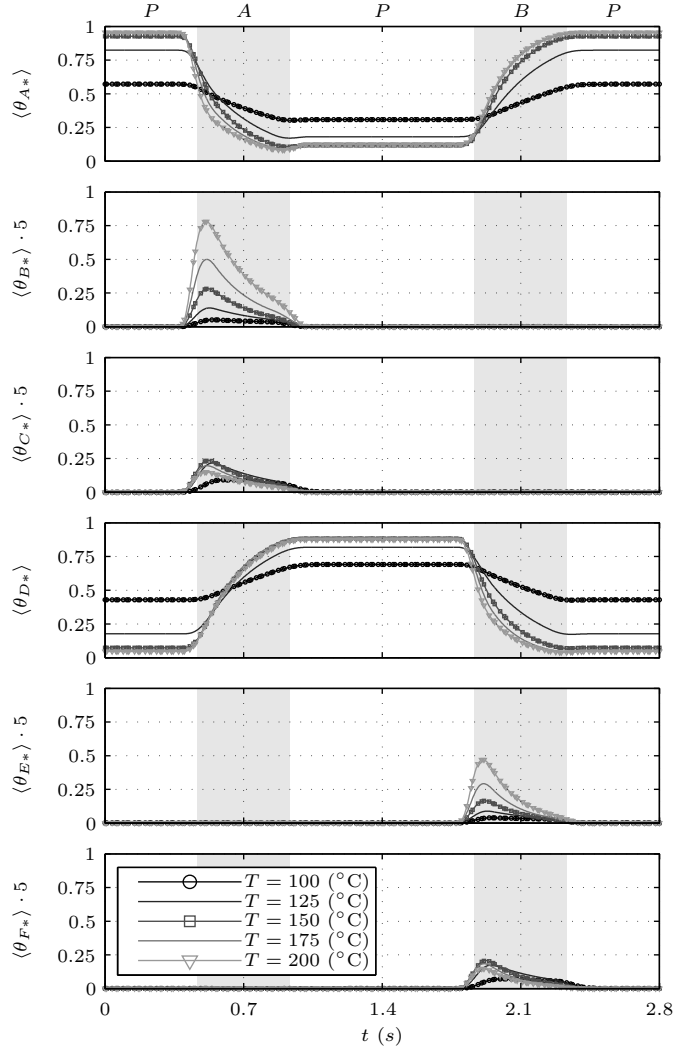

Figure 11: Projection of the fractional surface coverage limit-cycle dynamics sampled in the temperature range $T \in [100, 200]$ ($^{\circ}\text{C}$) with the pulse sequence $[\widetilde{\Delta t}_{\alpha}, \widetilde{\Delta t}_{\beta}] = [0.4, 0.8]$ (s). The symbol $(-)$ shows the simulated integral mean value of $\langle \theta_{\kappa} \rangle$ and $\kappa \in \{A^*, B^*, C^*, D^*\}$ in $\zeta \in [\zeta_0, \zeta_{\text{end}}]$ (m), while the corresponding solutions from the collocation method at the Radau collocation point locations are shown by (\circ) for $T = 100$ ($^{\circ}\text{C}$), (\square) for $T = 150$ ($^{\circ}\text{C}$), and (∇) for $T = 200$ ($^{\circ}\text{C}$). The shaded rectangles indicate the precursor pulse interval endpoints.

823 surface saturates with the precursor adduct, B^* , through Reaction (R2a), and
 824 the precursor adduct in its transition state, C^* , through Reaction (R2b). The
 825 adduct in the transition state is also subject to the ligand-elimination reaction
 826 (Reaction (R2c)), which governs the formation of D^* onto which the H_2O pre-
 827 cursor can adsorb. The H_2O half-reaction (see Reaction (R3)) can subsequently
 828 proceed in an analogous manner, ultimately resulting in the reformation of A^*
 829 through Reaction (R3c). Fig. 11 also shows that the fractional surface coverages
 830 of adduct species, $\kappa \in \{B^*, E^*\}$, and the corresponding adducts in their tran-
 831 sition states, $\kappa \in \{C^*, F^*\}$, are approximately five to ten times smaller than
 832 the coverages of the permanently bound species, $\kappa \in \{A^*, D^*\}$. It is impor-
 833 tant to determine the intermediate surface state coverage of these species since
 834 they are very difficult to detect experimentally, as surface state measurements
 835 correspond to permanently bound species (Travis and Adomaitis, 2013b).

836 Figs. 12 and 13 present alternative views of the fractional surface cover-
 837 age limit-cycle dynamics associated with the $Zn(C_2H_5)_2$ half-reaction (Reac-
 838 tion (R2)) and the H_2O half-reaction (see Reaction (R3)), respectively. The
 839 limit-cycle solutions can be easily identified in the phase plane portraits, and it
 840 is evident that the projected surface state trajectories depicted in Fig. 11 are
 841 closed curves, which means that all states conform to periodic boundary condi-
 842 tions over the time horizon $[t_0, t_f]$. The closed trajectories show the evolution
 843 of the fractional surface coverage with time, with a counter-clockwise direction
 844 of motion (i.e. the direction of increasing time) from the initial composition in
 845 Fig. 11. It is noteworthy, that the closed curves for $\langle \theta_\kappa \rangle$ shown in Figs. 11–
 846 13 are spatial averages over the domain $\zeta \in [\zeta_0, \zeta_{\text{end}}]$ (see Figure 1b), in order
 847 to make the figures clear. However, it must be remembered that Eq. (16) is
 848 a PDE, spatially discretized with FVM elements (see Section 4.5), which im-
 849 plies that $N_{\text{FVM}} \times N_\kappa$ limit-cycles appear throughout the entire spatial domain
 850 $z \in [z_0, z_{\text{end}}]$. Consequently, $N_{\text{FVM}} \times (N_\kappa - 1)$ terminal constraints (see Eq. (24))
 851 must also be fulfilled. Finally, Figs. 10–13 reveal rigorous limit-cycle dynamics
 852 for both the gas-phase and surface state species, and for the ALD film growth.
 853 These dynamics are essential for process analysis, design and optimization.

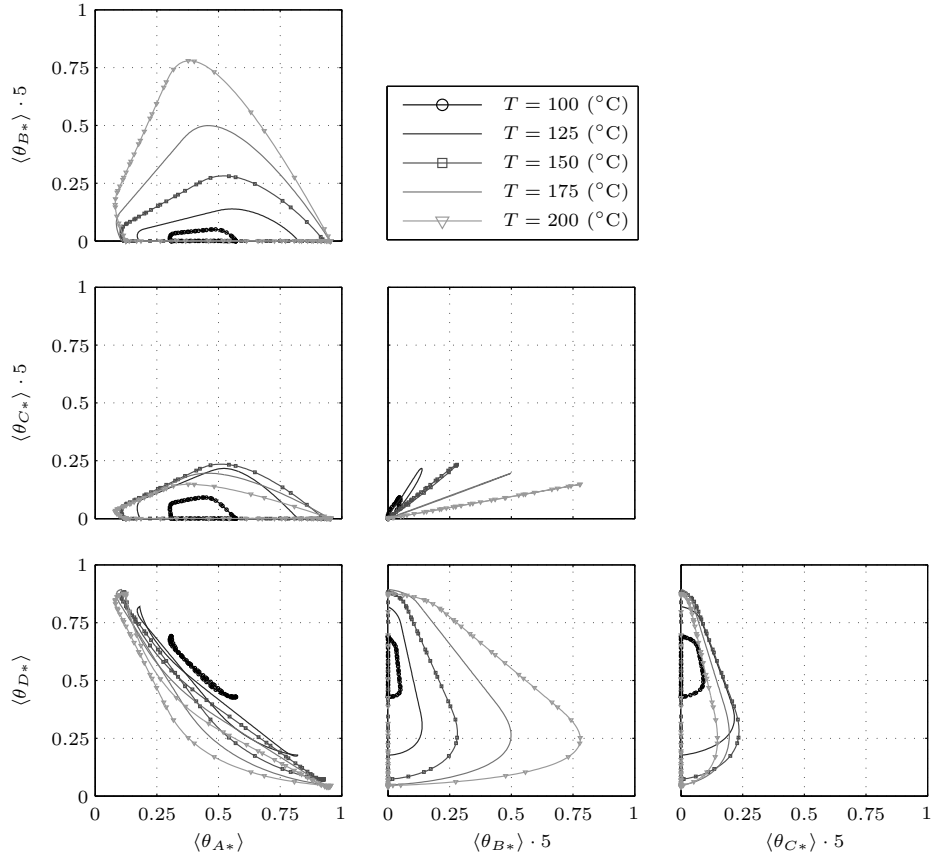

Figure 12: Phase plane portrait of the fractional surface coverage limit-cycle dynamics relevant to the $\text{Zn}(\text{C}_2\text{H}_5)_2$ precursor ALD half-reaction (Reaction (R2)) in the temperature range $T \in [100, 200]$ ($^\circ\text{C}$). (—) shows the simulated integral mean value of $\langle \theta_\kappa \rangle$ and $\kappa \in \{A^*, B^*, C^*, D^*\}$ in $\zeta \in [\zeta_0, \zeta_{\text{end}}]$ (m), while the corresponding solutions from the collocation method at the Radau collocation point locations are shown by (o) for $T = 100$ ($^\circ\text{C}$), (\square) for $T = 150$ ($^\circ\text{C}$), and (∇) for $T = 200$ ($^\circ\text{C}$).

854 8. Concluding Remarks

855 In this paper, a novel physically based model of a viscous continuous cross-
856 flow ALD reactor with temporally separated precursor pulsing was developed
857 and applied to ZnO ALD with $\text{Zn}(\text{C}_2\text{H}_5)_2$ and H_2O precursors. Model compo-
858 nents that describe reactor-scale gas-phase dynamics and surface state dynamics

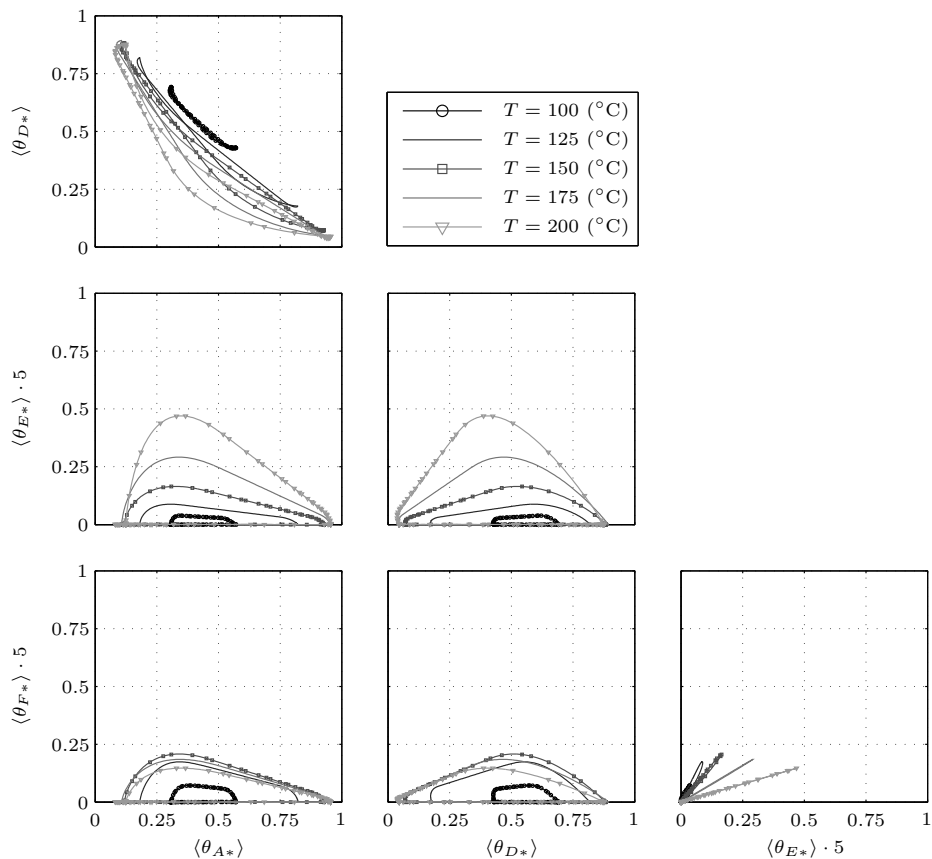

Figure 13: Phase plane portrait of the fractional surface coverage limit-cycle dynamics relevant to the H_2O precursor ALD half-reaction (Reaction (R3)) in the temperature range $T \in [100, 200]$ ($^\circ\text{C}$). (—) shows the simulated integral mean value of $\langle \theta_\kappa \rangle$ and $\kappa \in \{A^*, D^*, E^*, F^*\}$ in $\zeta \in [\zeta_0, \zeta_{\text{end}}]$ (m), while the corresponding solutions from the collocation method at the Radau collocation point locations are shown by (o) for $T = 100$ ($^\circ\text{C}$), (\square) for $T = 150$ ($^\circ\text{C}$), and (∇) for $T = 200$ ($^\circ\text{C}$).

859 have been integrated to accurately characterize the continuous, cyclic ALD re-
 860 actor operation that is described by limit-cycle dynamic solutions. The steady
 861 cyclic operation was discretized using a Radau collocation scheme in time and
 862 solved using the CasADi interface to IPOPT. The surface-reaction model, which
 863 accounts for the temporal evolution of the growth surface composition, is gov-

864 erned by the reaction rate expressions of the trapping-mediated mechanism, in
865 which it is assumed that both precursors follow structurally similar reaction
866 sequences. These sequences are initiated by the formation of adsorption and
867 precursor adducts, which is followed by an adduct/transition-state equilibrium
868 reaction that is terminated with an irreversible reaction in which ligands are
869 eliminated.

870 The work described in this paper was motivated by the predictive capabil-
871 ities of physically based ALD process models, as such models can be used in
872 the design of novel reactors and in the optimization of deposition conditions.
873 For this reason, a comprehensive study of *in situ* growth kinetics with QCM di-
874 agnostics was carried out. This provided quantitative submonolayer resolution
875 of the mass gain that occurs during a single ALD pulse sequence, from which
876 the Arrhenius kinetic parameters involved in the ALD reaction intrinsic kinetic
877 mechanism were estimated using a general dynamic optimization problem.

878 The assessment of the accuracy and reliability of the parameter estimates
879 reported here, showed that the parameters are highly correlated, as expected.
880 These correlations arise from the complex interdependence between elementary
881 surface reactions involved in ALD and the intrinsic mathematical structure of
882 the Arrhenius equation, and could be reduced through optimal reparameter-
883 ization of the Arrhenius equation by means of the anti-correlation procedure
884 described by Schwaab et al. (2008). This improved the precision of the param-
885 eter estimates. Predictions from the model of the transient mass gain per unit
886 area of exposed surface QCM sensor (resolved for a single pulse sequence) agree
887 well with both calibration data and validation data, under a wide range of oper-
888 ating conditions. The predictions are associated with narrow confidence bands.
889 The model also predicts accurately the impacts of the precursor pulse duration
890 and of the deposition temperature on the film growth per limit cycle, and can
891 in this way distinguish between ALD in saturating and in non-saturating film
892 growth conditions.

893 The principal contribution of this paper is the rigorous transport/reaction
894 model that is based on PDAEs and the continuous reactor operation described

895 by limit-cycle solutions that are unambiguous for several applications. Another
896 important contribution is the dynamic procedure used to estimate parameters
897 from *in situ* experimental data in order to identify accurately kinetic data and
898 to develop novel ALD reaction intrinsic kinetic mechanisms. The fundamental
899 understanding of the ALD process that was obtained by analyzing the limit-cycle
900 dynamics for both the gas-phase and surface state species, and by analyzing the
901 ALD film growth, is of practical interest when scaling ALD processes to large-
902 surface-area substrates and high-throughput production.

903 **Acknowledgement**

904 The authors acknowledge the supported by the Swedish Research Council
905 under Grant no. 2006-3738. Fredrik Magnusson is a member of the LCCC
906 Linnaeus Center and the eLLIIT Excellence Center at Lund University.

907 **Nomenclature**

908 *Roman letters*

909	A'	cross section area of the reaction chamber	m^2
910	A_i	frequency factor in the Arrhenius equation	$(\text{mol m}^{-2})^{1-n_i} \text{Pa}^{-1} \text{s}^{-1}$,
911			$(\text{mol m}^{-2})^{1-n_i} \text{s}^{-1}$
912	\mathbf{C}	$(N_\beta \times N_\beta)$ parameter correlation matrix	—
913	$\mathcal{D}_{\alpha\beta}$	binary diffusivity	$\text{m}^2 \text{s}^{-1}$
914	E_i	activation energy	J mol^{-1}
915	\mathbf{F}	system of differential algebraic equations	—
916	$F_{(N_\beta, \varphi; \alpha)}$	Fisher's F -distribution	—
917	\mathbf{g}	response function	—
918	\mathbf{J}	parameter Jacobian matrix	—
919	k_i	reaction rate constant	$(\text{mol m}^{-2})^{1-n_i} \text{Pa}^{-1} \text{s}^{-1}$,
920			$(\text{mol m}^{-2})^{1-n_i} \text{s}^{-1}$
921	M_α	molar mass	kg mol^{-1}
922	m_s	film mass increment	kg m^{-2}
923	n_i	surface reaction order	—
924	p	pressure	Pa
925	\dot{Q}_α	volumetric flow rate at STP	$\text{Nm}^3 \text{s}^{-1}$
926	R	universal gas constant	$\text{J mol}^{-1} \text{K}^{-1}$
927	r_i	surface reaction rate	$\text{mol m}^{-2} \text{s}^{-1}$
928	S_α	source term in the general transport equation	$\text{kg m}^{-3} \text{s}^{-1}$
929	s^2	variance estimate of σ^2	—
930	T	temperature	K
931	t	time	s
932	$t_{(\varphi; \alpha/2)}$	Student's t -distribution	—
933	\mathbf{u}	design variables	—
934	v_z	linear velocity	m s^{-1}
935	\mathbf{W}	weight matrix	—
936	\mathbf{w}	algebraic variables	—
937	\mathbf{x}	state variables	—
938	\mathbf{y}	measured state variables	—
939	z	spatial coordinate	m

940 *Greek letters*

941	α	significance level	—
942	β	calibration parameter vector	—
943	Δt_α	pulse duration	s
944	δ_α	half-cycle average precursor dose	Langmuir
945	$\varepsilon_{\hat{\beta}_i}$	normalized margin of error	—
946	ζ	QCM local coordinate variable	m
947	θ_κ	fractional surface coverage of surface species	—
948	Λ	maximum molar concentration of surface sites	mol m^{-2}
949	μ	dynamic viscosity of the gas mixture	$\text{kg m}^{-1} \text{s}^{-1}$
950	ν	numbers of surface OH groups reacting	—
951		with each $\text{Zn}(\text{C}_2\text{H}_5)_2$	—
952	ξ_i	surface reaction stoichiometric coefficient	—
953	ρ	density of the gas mixture	kg m^{-3}
954	Σ	parameter covariance matrix	—
955	Φ	weighted sum of squared residuals	ng cm^{-2}
956	Π_α	characteristic function of t and Δt_α	—
957	φ	degrees of freedom	—
958	ω_α	mass fraction of gaseous species	—

959 *Subscripts and superscripts*

960	0	initial value	
961	α, β	gaseous species indices	
962	i	surface reaction index	
963	ι	calibration parameter index	
964	j	calibration and validation set index	
965	κ	surface species index	
966	q	quartz crystal	
967	STP	state variable at STP	
968	s	solid	
969	ref	state at the reference temperature	

970 **References**

- 971 Aarik, J., Aidla, A., Jaek, A., Leskelä, M., Niinisto, L., 1994a. In situ study
972 of a strontium β -diketonate precursor for thin-film growth by atomic layer
973 epitaxy. *Journal of Materials Chemistry* 4, 1239–1244.
- 974 Aarik, J., Aidla, A., Kasikov, A., Mändar, H., Rammula, R., Sammelseg, V.,
975 2006. Influence of carrier gas pressure and flow rate on atomic layer deposition
976 of HfO_2 and ZrO_2 thin films. *Applied Surface Science* 252 (16), 5723–5734.
- 977 Aarik, J., Aidla, A., Kukli, K., 1994b. In situ characterization of ALE growth
978 by reagent pulse delay times in a flow-type reactor. *Applied Surface Science*
979 75 (1-4), 180–184.
- 980 Aarik, J., Aidla, A., Mändar, H., Uustare, T., 2001. Atomic layer deposition of
981 titanium dioxide from TiCl_4 and H_2O : investigation of growth mechanism.
982 *Applied Surface Science* 172 (12), 148–158.
- 983 Aarik, J., Siimon, H., 1994. Characterization of adsorption in flow type atomic
984 layer epitaxy reactor. *Applied Surface Science* 81 (3), 281–287.
- 985 Adomaitis, R. A., 2010. Development of a multiscale model for an atomic layer
986 deposition process. *Journal of Crystal Growth* 312 (8), 1449–1452.
- 987 Åkesson, J., 2008. Optimica—An extension of Modelica supporting dynamic
988 optimization. In: 6th International Modelica Conference 2008. Modelica As-
989 sociation.
- 990 Åkesson, J., Årzén, K.-E., Gäfvert, M., Bergdahl, T., Tummescheit, H., 2010.
991 Modeling and optimization with Optimica and JModelica.org—Languages
992 and tools for solving large-scale dynamic optimization problems. *Computers
993 & Chemical Engineering* 34 (11), 1737–1749.
- 994 Alam, M. A., Green, M. L., 2003. Mathematical description of atomic layer
995 deposition and its application to the nucleation and growth of HfO_2 gate
996 dielectric layers. *Journal of Applied Physics* 94 (5), 3403–3413.

- 997 Andersson, J., Åkesson, J., Diehl, M., 2012a. CasADi: A Symbolic Package
998 for Automatic Differentiation and Optimal Control. In: Forth, S., Hovland,
999 P., Phipps, E., Utke, J., Walther, A. (Eds.), Recent Advances in Algorithmic
1000 Differentiation. Vol. 87 of Lecture Notes in Computational Science and
1001 Engineering. Springer Berlin Heidelberg, pp. 297–307.
- 1002 Andersson, N., Larsson, P.-O., Åkesson, J., Skålen, S., Carlsson, N., Nilsson, B.,
1003 2012b. Parameter Estimation of Dynamic Grade Transitions in a Polyethylene
1004 Plant. In: Proceedings of the 22nd European Symposium on Computer Aided
1005 Process Engineering. Elsevier B.V., London, pp. 1–5.
- 1006 Bakke, J. R., Pickrahn, K. L., Brennan, T. P., Bent, S. F., 2011. Nanoengineer-
1007 ing and interfacial engineering of photovoltaics by atomic layer deposition.
1008 *Nanoscale* 3, 3482–3508.
- 1009 Bard, Y., 1974. Nonlinear parameter estimation. Academic Press, New York.
- 1010 Bates, D. M., Watts, D. G., 1988. Nonlinear Regression Analysis and Its Appli-
1011 cations. John Wiley & Sons, Inc., New York.
- 1012 Baunemann, A., 2006. Precursor chemistry of Tantalum and Niobium nitride
1013 for MOCVD and ALD applications. Ph.D. thesis, Ruhr-University, Bochum.
- 1014 Biegler, L. T., 2010. Nonlinear Programming: Concepts, Algorithms, and Ap-
1015 plications to Chemical Processes. Society for Industrial Mathematics, PA,
1016 USA.
- 1017 Biegler, L. T., Cervantes, A. M., Wächter, A., 2002. Advances in simultaneous
1018 strategies for dynamic process optimization. *Chemical Engineering Science*
1019 57 (4), 575–593.
- 1020 Bird, R. B., Stewart, W. E., Lightfoot, E. N., 1960. Transport Phenomena, 2nd
1021 Edition. John Wiley & Sons, Inc., New York.
- 1022 Brereton, R. G., 2003. Chemometrics, Data Analysis for the Laboratory and
1023 Chemical Plant, 1st Edition. John Wiley & Sons, Inc., Chichester.

- 1024 Carcia, P. F., McLean, R. S., Groner, M. D., Dameron, A. A., George, S. M.,
1025 2009. Gas diffusion ultrabarriers on polymer substrates using Al_2O_3 atomic
1026 layer deposition and sin plasma-enhanced chemical vapor deposition. *Journal*
1027 *of Applied Physics* 106 (2), 023533.
- 1028 Cleveland, E. R., Henn-Lecordier, L., Rubloff, G. W., 2012. Role of surface
1029 intermediates in enhanced, uniform growth rates of TiO_2 atomic layer de-
1030 position thin films using titanium tetraisopropoxide and ozone. *Journal of*
1031 *Vacuum Science & Technology A* 30 (1), 01A150.
- 1032 Davis, M. E., 1984. *Numerical Methods and Modeling for Chemical Engineers*,
1033 1st Edition. John Wiley & Sons, Inc., New York.
- 1034 Deminsky, M., Knizhnik, A., Belov, I., Umanskii, S., Rykova, E., Bagatur'yants,
1035 A., et al., 2004. Mechanism and kinetics of thin zirconium and hafnium oxide
1036 film growth in an ALD reactor. *Surface Science* 549 (1), 67–86.
- 1037 Dillon, A. C., Ott, A. W., Way, J. D., George, S. M., 1995. Surface chemistry
1038 of Al_2O_3 deposition using $\text{Al}(\text{CH}_3)_3$ and H_2O in a binary reaction sequence.
1039 *Surface Science* 322 (1–3), 230–242.
- 1040 Draper, N. R., Smith, H., 1998. *Applied Regression Analysis*, 3rd Edition. John
1041 Wiley & Sons, Inc., New York.
- 1042 Dunham, G. C., Benson, N. H., Petelenz, D., Janata, J., 1995. Dual quartz
1043 crystal microbalance. *Analytical Chemistry* 67 (2), 267–272.
- 1044 Edgar, T. F., Himmelblau, D. M., 1988. *Optimization of Chemical Processes*,
1045 1st Edition. McGraw-Hill, New York.
- 1046 Elam, J. W., George, S. M., 2003. Growth of $\text{ZnO}/\text{Al}_2\text{O}_3$ alloy films using atomic
1047 layer deposition techniques. *Chemistry of Materials* 15 (4), 1020–1028.
- 1048 Elam, J. W., Groner, M. D., George, S. M., 2002. Viscous flow reactor with
1049 quartz crystal microbalance for thin film growth by atomic layer deposition.
1050 *Review of Scientific Instruments* 73 (8), 2981–2987.

- 1051 Elam, J. W., Pellin, M. J., 2005. GaPO₄ sensors for gravimetric monitoring
1052 during atomic layer deposition at high temperatures. *Analytical Chemistry*
1053 77 (11), 3531–3535.
- 1054 Elliott, S. D., 2012. Atomic-scale simulation of ALD chemistry. *Semiconductor*
1055 *Science and Technology* 27 (7), 074008.
- 1056 Fan, J.-F., Toyoda, K., 1992. Self-limiting behavior of the growth of Al₂O₃
1057 using sequential vapor pulses of TMA and H₂O₂. *Applied Surface Science*
1058 60-61, 765–769.
- 1059 Ferguson, J., Weimer, A. W., George, S. M., 2000. Atomic layer deposition of
1060 ultrathin and conformal Al₂O₃ films on BN particles 371 (1–2), 95–104.
- 1061 Fornberg, B., 1988. Generation of finite difference formulas on arbitrarily spaced
1062 grids. *Mathematics of Computation* 51 (184), 699–706.
- 1063 Franceschini, G., Macchietto, S., 2008. Model-based design of experiments for
1064 parameter precision: State of the art. *Chemical Engineering Science* 63 (19),
1065 4846–4872.
- 1066 George, S. M., 2010. Atomic layer deposition: An overview. *Chemical Reviews*
1067 110 (1), 111–131.
- 1068 Granneman, E., Fischer, P., Pierreux, D., Terhorst, H., Zagwijn, P., 2007. Batch
1069 ALD: Characteristics, comparison with single wafer ALD, and examples. *Sur-*
1070 *face and Coatings Technology* 201 (22-23), 8899–8907.
- 1071 Hangos, K. M., Cameron, I. T., 2001. Process modelling and model analysis. In:
1072 Stephanopoulos, G., Perkins, J. (Eds.), *Process Systems Engineering*. Vol. 4.
1073 Academic Press, London.
- 1074 Henn-Lecordier, L., Anderle, M., Robertson, E., Rubloff, G. W., 2011. Impact of
1075 parasitic reactions on wafer-scale uniformity in water-based and ozone-based
1076 atomic layer deposition. *Journal of Vacuum Science & Technology A* 29 (5),
1077 051509.

- 1078 Hindmarsh, A. C., Brown, P. N., Grant, K. E., Lee, S. L., Serban, R., Shumaker,
1079 D. E., et al., 2005. SUNDIALS: Suite of nonlinear and differential/algebraic
1080 equation solvers. *ACM Transactions on Mathematical Software* 31 (3), 363–
1081 396.
- 1082 Hirschfelder, J. O., Curtiss, C. F., Bird, R. B., 1964. *Molecular Theory of Gases*
1083 *and Liquids*, 2nd Edition. John Wiley & Sons, Inc., New York.
- 1084 Holmqvist, A., Törndahl, T., Stenström, S., 2012. A model-based methodol-
1085 ogy for the analysis and design of atomic layer deposition processes—Part
1086 I: Mechanistic modelling of continuous flow reactors. *Chemical Engineering*
1087 *Science* 81, 260–272.
- 1088 Holmqvist, A., Törndahl, T., Stenström, S., 2013a. A model-based methodol-
1089 ogy for the analysis and design of atomic layer deposition processes—Part
1090 II: Experimental validation and mechanistic analysis. *Chemical Engineering*
1091 *Science* 94, 316–329.
- 1092 Holmqvist, A., Törndahl, T., Stenström, S., 2013b. A model-based methodology
1093 for the analysis and design of atomic layer deposition processes—Part III:
1094 Constrained multi-objective optimization. *Chemical Engineering Science* 96,
1095 71–86.
- 1096 Juppo, M., Rahtu, A., Ritala, M., Leskelä, M., 2000. In situ mass spectrometry
1097 study on surface reactions in atomic layer deposition of Al_2O_3 thin films from
1098 trimethylaluminum and water. *Langmuir* 16 (8), 4034–4039.
- 1099 Jur, J. S., Parsons, G. N., 2011. Atomic layer deposition of Al_2O_3 and ZnO
1100 at atmospheric pressure in a flow tube reactor. *ACS Applied Materials &*
1101 *Interfaces* 3 (2), 299–308.
- 1102 Kuse, R., Kundu, M., Yasuda, T., Miyata, N., Toriumi, A., 2003. Effect of pre-
1103 cursor concentration in atomic layer deposition of Al_2O_3 . *Journal of Applied*
1104 *Physics* 94 (10), 6411–6416.

- 1105 Larrabee, T. J., Mallouk, T. E., Allara, D. L., 2013. An atomic layer deposi-
1106 tion reactor with dose quantification for precursor adsorption and reactivity
1107 studies. *Review of Scientific Instruments* 84 (1), 014102.
- 1108 Lei, W., Henn-Lecordier, L., Anderle, M., Rubloff, G. W., Barozzi, M., Bersani,
1109 M., 2006. Real-time observation and optimization of tungsten atomic layer
1110 deposition process cycle. *Journal of Vacuum Science & Technology B* 24 (2),
1111 780–789.
- 1112 Lim, J.-W., Park, J.-S., Kang, S.-W., 2000. Kinetic modeling of film growth
1113 rates of TiN films in atomic layer deposition. *Journal of Applied Physics*
1114 87 (9), 4632–4634.
- 1115 Lu, C.-S., Lewis, O., 1972. Investigation of film-thickness determination by os-
1116 cillating quartz resonators with large mass load. *Journal of Applied Physics*
1117 43 (11), 4385–4390.
- 1118 Magnusson, F., Åkesson, J., Sep 2012. Collocation methods for optimization in
1119 a Modelica environment. In: 9th International Modelica Conference. Munich,
1120 Germany.
- 1121 Masel, R. I., 1996. *Principle of Adsorption and Reaction on Solid Surface*, 1st
1122 Edition. John Wiley & Sons, Inc., New York.
- 1123 Matero, R., Rahtu, A., Ritala, M., Leskelä, M., Sajavaara, T., 2000. Effect of
1124 water dose on the atomic layer deposition rate of oxide thin films. *Thin Solid*
1125 *Films* 368 (1), 1–7.
- 1126 McKay, M. D., Beckman, R. J., Conover, W. J., 1979. A comparison of three
1127 methods for selecting values of input variables in the analysis of output from
1128 a computer code. *Technometrics* 21 (2), 239–245.
- 1129 Miikkulainen, V., Leskelä, M., Ritala, M., Puurunen, R. L., 2013. Crystallinity
1130 of inorganic films grown by atomic layer deposition: Overview and general
1131 trends. *Journal of Applied Physics* 113 (2), 021301.

- 1132 Mousa, M. B. M., Oldham, C. J., Jur, J. S., Parsons, G. N., 2012. Effect of
1133 temperature and gas velocity on growth per cycle during Al_2O_3 and ZnO
1134 atomic layer deposition at atmospheric pressure. *Journal of Vacuum Science
1135 & Technology A* 30 (1), 01A155.
- 1136 Musgrave, C. B., 2012. Theoretical modeling of ald processes. In: Pinna, N.,
1137 Knez, M. (Eds.), *Atomic Layer Deposition of Nanostructured Materials*, 1st
1138 Edition. Wiley-VCH Verlag GmbH & Co. KGaA, pp. 1–21.
- 1139 Park, H.-S., Min, J.-S., Lim, J.-W., Kang, S.-W., 2000. Theoretical evaluation
1140 of film growth rate during atomic layer epitaxy. *Applied Surface Science* 158,
1141 81–91.
- 1142 Poodt, P., Cameron, D. C., Dickey, E., George, S. M., Kuznetsov, V., Parsons,
1143 G. N., et al., 2012. Spatial atomic layer deposition: A route towards further
1144 industrialization of atomic layer deposition. *Journal of Vacuum Science &
1145 Technology A* 30 (1), 010802.
- 1146 Price, K. V., 1999. An Introduction to Differential Evolution. In: Corne, D.,
1147 Dorigo, M., Glover, F. (Eds.), *New Ideas in Optimization*. McGraw-Hill, Lon-
1148 don, pp. 79–108.
- 1149 Puurunen, R. L., 2003. Growth per cycle in atomic layer deposition: A theoret-
1150 ical model. *Chemical Vapor Deposition* 9 (5), 249–257.
- 1151 Puurunen, R. L., 2004. Analysis of hydroxyl group controlled atomic layer de-
1152 position of hafnium dioxide from hafnium tetrachloride and water. *Journal of
1153 Applied Physics* 95 (9), 4777–4786.
- 1154 Puurunen, R. L., 2005a. Correlation between the growth-per-cycle and the sur-
1155 face hydroxyl group concentration in the atomic layer deposition of aluminum
1156 oxide from trimethylaluminum and water. *Applied Surface Science* 245 (1–4),
1157 6–10.

- 1158 Puurunen, R. L., 2005b. Surface chemistry of atomic layer deposition: A case
1159 study for the trimethylaluminum/water process. *Journal of Applied Physics*
1160 97 (12), 121301.
- 1161 Rahtu, A., Alaranta, T., Ritala, M., 2001. In situ quartz crystal microbal-
1162 ance and quadrupole mass spectrometry studies of atomic layer deposition
1163 of aluminum oxide from trimethylaluminum and water. *Langmuir* 17 (21),
1164 6506–6509.
- 1165 Rahtu, A., Ritala, M., 2002a. Compensation of temperature effects in quartz
1166 crystal microbalance measurements. *Applied Physics Letters* 80 (3), 521–523.
- 1167 Rahtu, A., Ritala, M., 2002b. Reaction mechanism studies on the zirconium
1168 chloride-water atomic layer deposition process. *Journal of Materials Chem-*
1169 *istry* 12 (5), 1484–1489.
- 1170 Reid, R. C., Prausnitz, J. M., Poling, B. E., 1988. *The Properties of Gases and*
1171 *Liquids*, 4th Edition. McGraw-Hill, New York.
- 1172 Ren, J., 2009. Initial growth mechanism of atomic layer deposition of ZnO on
1173 the hydroxylated Si(100)-2×1: A density functional theory study. *Applied*
1174 *Surface Science* 255 (11), 5742–5745.
- 1175 Riha, S. C., Libera, J. A., Elam, J. W., Martinson, A. B. F., 2012. Design and
1176 implementation of an integral wall-mounted quartz crystal microbalance for
1177 atomic layer deposition. *Review of Scientific Instruments* 83 (9), 094101.
- 1178 Rimensberger, T., Rippin, D. W. T., 1986. Sequential experimental design for
1179 precise parameter estimation. 1. Use of reparameterization. *Comments. In-*
1180 *dustrial & Engineering Chemistry Process Design and Development* 25 (4),
1181 1042–1044.
- 1182 Ritala, M., Leskelä, M., 2002. *Handbook of Thin Film Materials*. Vol. 1. Aca-
1183 *ademic Press*, New York.

- 1184 Ritala, M., Niinisto, J., 2009. Industrial applications of atomic layer deposition.
1185 ECS Transactions 25 (8), 641–652.
- 1186 Rocklein, M. N., George, S. M., 2003. Temperature-induced apparent mass
1187 changes observed during quartz crystal microbalance measurements of atomic
1188 layer deposition. Analytical Chemistry 75 (19), 4975–4982.
- 1189 Sauerbrey, G., 1959. Verwendung von schwingquarzen zur wägung dünner
1190 schichten und zur mikrowägung. Zeitschrift für Physik A Hadrons and Nuclei
1191 155, 206–222.
- 1192 Schiesser, W. E., 1991. The Numerical Method of Lines: Integration of Partial
1193 Differential Equations, 1st Edition. Academic Press, San Diego.
- 1194 Schwaab, M., Lemos, L. P., Pinto, J. C., 2008. Optimum reference temperature
1195 for reparameterization of the Arrhenius equation. Part 2: Problems involving
1196 multiple reparameterizations. Chemical Engineering Science 63 (11), 2895–
1197 2906.
- 1198 Schwaab, M., Pinto, J. C., 2007. Optimum reference temperature for reparam-
1199 eterization of the Arrhenius equation. Part 1: Problems involving one kinetic
1200 constant. Chemical Engineering Science 62 (10), 2750–2764.
- 1201 Schwaab, M., Pinto, J. C., 2008. Optimum reparameterization of power function
1202 models. Chemical Engineering Science 63 (18), 4631–4635.
- 1203 Semiconductor Industry Association, 2011. Modeling and simula-
1204 tions. In: The International Technology Roadmap for Semiconduc-
1205 tors, 2011th Edition. San Jose, CA, pp. 1–45, [Online]. Available:
1206 <http://public.itrs.net/reports.html>.
- 1207 Sneh, O., Clark-Phelps, R. B., Londergan, A. R., Winkler, J., Seidel, T. E., 2002.
1208 Thin film atomic layer deposition equipment for semiconductor processing.
1209 Thin Solid Films 402 (1-2), 248–261.

- 1210 Storn, R., Price, K., 1997. Differential Evolution - A simple and efficient heuristic
1211 for global optimization over continuous spaces. *Journal of Global Optimization* 11 (4), 341–359.
1212
- 1213 Suntola, T., 1992. Atomic layer epitaxy. *Thin Solid Films* 216 (1), 84–89.
- 1214 The Modelica Association, 2012. The Modelica Association Home Page.
1215 <http://www.modelica.org>.
- 1216 Törndahl, T., Platzer-Björkman, C., Kessler, J., Edoff, M., 2007. Atomic layer
1217 deposition of $Zn_{1-x}Mg_xO$ buffer layers for Cu(In, Ga)Se₂ solar cells. *Progress*
1218 *in Photovoltaics: Research and Applications* 15 (3), 225–235.
- 1219 Travis, C. D., Adomaitis, R. A., 2013a. Dynamic modeling for the design and
1220 cyclic operation of an atomic layer deposition (ALD) reactor. *Processes* 1 (2),
1221 128–152.
- 1222 Travis, C. D., Adomaitis, R. A., 2013b. Modeling ALD surface reaction and process
1223 dynamics using absolute reaction rate theory. *Chemical Vapor Deposition*
1224 19, 1–11.
- 1225 Vegliò, F., Trifoni, M., Pagnanelli, F., Toro, L., 2001. Shrinking core model with
1226 variable activation energy: A kinetic model of manganiferous ore leaching with
1227 sulphuric acid and lactose. *Hydrometallurgy* 60 (2), 167–179.
- 1228 Wächter, A., Biegler, L. T., 2006. On the implementation of an interior-point
1229 filter line-search algorithm for large-scale nonlinear programming. *Mathematical*
1230 *Programming* 106 (1), 25–57.
- 1231 Wajid, A., 1991. Improving the accuracy of a quartz crystal microbalance with
1232 automatic determination of acoustic impedance ratio. *Review of Scientific*
1233 *Instruments* 62 (8), 2026–2033.
- 1234 Watts, D. G., 1994. Estimating parameters in nonlinear rate equations. *Canadian*
1235 *Journal of Chemical Engineering* 72 (4), 701–710.

- 1236 Widjaja, Y., Musgrave, C. B., 2002a. Atomic layer deposition of hafnium oxide:
1237 A detailed reaction mechanism from first principles. *The Journal of Chemical*
1238 *Physics* 117 (5), 1931–1934.
- 1239 Widjaja, Y., Musgrave, C. B., 2002b. Quantum chemical study of the elementary
1240 reactions in zirconium oxide atomic layer deposition. *Applied Physics Letters*
1241 81 (2), 304–306.
- 1242 Wilke, C. R., 1950. A viscosity equation for gas mixtures. *Journal of Chemical*
1243 *Physics* 18 (4), 517–519.
- 1244 Wind, R. A., George, S. M., 2010. Quartz Crystal Microbalance Studies of
1245 Al_2O_3 Atomic Layer Deposition Using Trimethylaluminum and Water at 125
1246 °C. *The Journal of Physical Chemistry A* 114 (3), 1281–1289.
- 1247 Wolden, C. A., Kurtin, J., Baxter, J. B., Repins, I., Shaheen, S. E., Torvik, J. T.,
1248 et al., 2011. Photovoltaic manufacturing: Present status, future prospects,
1249 and research needs. *Journal of Vacuum Science & Technology A* 29 (3),
1250 030801.
- 1251 Yanguas-Gil, A., Elam, J. W., 2012. Simple model for atomic layer deposition
1252 precursor reaction and transport in a viscous-flow tubular reactor. *Journal of*
1253 *Vacuum Science & Technology A* 30 (1), 01A159.
- 1254 Ylilammi, M., 1995. Mass transport in atomic layer deposition carrier gas reac-
1255 tors. *Journal of The Electrochemical Society* 142 (7), 2474–2479.
- 1256 Yousfi, E. B., Fouache, J., Lincot, D., 2000. Study of atomic layer epitaxy of
1257 zinc oxide by in-situ quartz crystal microgravimetry. *Applied Surface Science*
1258 153 (4), 223–234.