



# LUND UNIVERSITY

## Host response in sepsis

Berkestedt, Ingrid

2009

[Link to publication](#)

*Citation for published version (APA):*

Berkestedt, I. (2009). *Host response in sepsis*. Avd för anesthesiologi och intensivvård.

*Total number of authors:*

1

### General rights

Unless other specific re-use rights are stated the following general rights apply:

Copyright and moral rights for the publications made accessible in the public portal are retained by the authors and/or other copyright owners and it is a condition of accessing publications that users recognise and abide by the legal requirements associated with these rights.

- Users may download and print one copy of any publication from the public portal for the purpose of private study or research.
- You may not further distribute the material or use it for any profit-making activity or commercial gain
- You may freely distribute the URL identifying the publication in the public portal

Read more about Creative commons licenses: <https://creativecommons.org/licenses/>

### Take down policy

If you believe that this document breaches copyright please contact us providing details, and we will remove access to the work immediately and investigate your claim.

LUND UNIVERSITY

PO Box 117  
221 00 Lund  
+46 46-222 00 00

## CONTENTS

CONTENTS	9
THESIS AT A GLANCE	10
ABSTRACT	12
LIST OF PAPERS	13
ABBREVIATIONS	14
BACKGROUND	15
Endothelium	15
White blood cells	18
Antimicrobial peptides and proteins	19
Contact system	21
AIMS OF THE STUDIES	23
MATERIALS AND METHODS	24
Preparation of human omental artery and vein	24
Measurement of smooth muscle force	24
Reverse transcriptase–polymerase chain reaction	26
ICU patients	27
Control patients	29
Blood samples	29
Radial diffusion assay	30
Statistical analysis	31
RESULTS AND DISCUSSION	32
Effects of LL-37 in vascular control	32
Glycosaminoglycans in sepsis and immunity	36
Levels of AMPs in severe sepsis	37
Contact system activation in severe sepsis/septic shock	40
CONCLUSIONS	42
POPULÄRVETENSKAPLIG SAMMANFATTNING	43
ACKNOWLEDGEMENTS	45
REFERENCES	47

## THESIS AT A GLANCE

<i>Questions</i>	<i>Methods</i>	<i>Results</i>	<i>Conclusions</i>
Does the antimicrobial peptide LL-37 affect vascular tone?	Isometric measurement of smooth muscle tension in human vessels <i>in vitro</i>  RT-PCR	LL-37 at $\mu\text{M}$ concentrations induces a concentration- and endothelium-dependent relaxation in veins but not arteries.	LL-37 could contribute to the vasodilation seen in septic shock.
Are plasma levels of glycosaminoglycans and syndecan-1 affected in sepsis patients?	Glycosaminoglycan assay using a cationic dye  ELISA	Glycosaminoglycan and syndecan-1 plasma levels are increased in septic shock patients and the glycosaminoglycan level correlates to mortality.	The increased levels of glycosaminoglycans could in part reflect endothelial damage and result in a decreased effectiveness of innate immunity.
Can glycosaminoglycans in relevant concentrations inhibit antimicrobial peptides?	Radial diffusion assay	Glycosaminoglycans inhibited <i>in vitro</i> the endogenous antibacterial activity of plasma and isolated antimicrobial peptides.	

<p>What are the plasma levels of antimicrobial peptides in sepsis patients compared to controls?</p> <p>Do they correlate to mortality, circulatory disturbances, inflammatory activation and/or neutrophil activation?</p>	<p>ELISA</p>	<p>The levels of most antimicrobial peptides studied are increased in sepsis patients and generally correlate to circulatory derangement, inflammatory activation and levels of myeloperoxidase but not to mortality.</p>	<p>The increase in levels of antimicrobial peptides could reflect neutrophil activation.</p>
<p>Is bradykinin clinically important in established severe human sepsis?</p>	<p>ELISA Western Blot Total plasma protein measurement</p>	<p>High-molecular-weight kininogen and bradykinin plasma levels are decreased in sepsis patients.</p>	<p>Low bradykinin levels question the role of contact system activation in severe sepsis and could be due to substrate depletion reflected by low high-molecular-weight kininogen levels.</p>

## ABSTRACT

Sepsis is a serious condition characterized by a systemic inflammatory response to an infection. Increased vascular leakage, vasodilation and heart failure cause circulatory disturbances challenging the intensivist. Despite modern medication and high technology supportive care, mortality is high. Key strategies include to find and take care of causative agents at the infection site. Unfortunately, the microbes are sometimes “slippery small ones” protecting themselves by for example resistance against antibiotics. But our body is amazing! For example cells, such as neutrophil granulocytes, produce antibiotic substances (antimicrobial peptides, AMPs). Increased knowledge of the host response in sepsis will aid in refining and developing new treatment.

We investigated the effect of the AMP, LL-37, on smooth muscle activity in isolated human omental vessels and found that it causes formyl peptide receptor-like 1 mediated dilation in the veins mainly via action of endothelium-derived hyperpolarizing factor.

Earlier studies have shown that increased levels of glycosaminoglycans (GAGs) inhibit the action of AMPs in chronic wounds. We found increased plasma levels of GAGs in sepsis patients correlating to mortality and level of circulatory derangement. GAGs at concentrations relevant to sepsis patients inhibited the antimicrobial action of AMPs in vitro.

Plasma levels of AMPs were generally higher in sepsis patients than in controls and correlated to inflammatory activation, circulatory derangement and neutrophil activity.

Finally, we found that the contact system is activated in patients with severe sepsis reflected by decreased levels of high-molecular-weight kininogen. The levels of the main effector, bradykinin, were, however, also decreased, suggesting substrate depletion in the state of established severe sepsis.

## LIST OF PAPERS

This thesis is based on the following papers, referred to in the text by their roman numerals.

- I Berkestedt I, Nelson A, Bodelsson M. Endogenous antimicrobial peptide LL-37 induces human vasodilatation. *Br J Anaesth* 2008 100(6):803-9.
- II Nelson A, Berkestedt I, Schmidtchen A, Ljunggren L, Bodelsson M. Increased levels of glycosaminoglycans during septic shock: relation to mortality and the antibacterial actions of plasma. *Shock* 2008 30(6):623-7.
- III Berkestedt I, Herwald H, Ljunggren L, Nelson A, Bodelsson M. Plasma levels of antimicrobial polypeptides in patients with severe sepsis. In manuscript.
- IV Berkestedt I, Andersson P, Herwald H, Karlsson Valik J, Sörensen O, Bodelsson M. Early depletion of contact system in patients with severe sepsis. Submitted.

## ABBREVIATIONS

ALX	Lipoxin A <sub>4</sub> receptor
AMP	Antimicrobial peptide
ANOVA	Analysis of variance
BPI	Bactericidal/permeability-increasing protein
CNS	Central nervous system
CRP	C-reactive protein
EDHF	Endothelium-derived hyperpolarizing factor
EDTA	Ethylenediamine tetra-acetic acid
ELISA	Enzyme-linked immunosorbent assay
ET-1	Endothelin-1
FPRL1	Formyl peptide receptor-like 1
GAG	Glycosaminoglycan
GAPDH	Glyceraldehyde-3-phosphate dehydrogenase
HBP	Heparin-binding protein
HK	High-molecular-weight kininogen
HNP1-3	Alpha-defensins
ICU	Intensive care unit
KRS	Krebs-Ringer solution
L-NAME	L-N <sup>G</sup> -nitroarginine methyl ester
LPS	Lipopolysaccharides
MAP	Mean arterial pressure
MOF	Multi organ failure
MPO	Myeloperoxidase
NA	Noradrenaline
NO	Nitric oxide
NOS	Nitric oxide synthase
PMN	Polymorphonuclear leukocyte
PG	Proteoglycan
RDA	Radial diffusion assay
SIRS	Systemic inflammatory response syndrome
SOFA	Sequential organ failure assessment
SP	Substance P
WBC	White blood cell count
WKY	WKY/MVm
WRW4	WRW/MVm

## **BACKGROUND**

A significant amount of research is going on in the area of sepsis, a status often caused by a bacterial infection, with a multifactorial and complicated pathophysiology [1], followed by high mortality. At the intensive care unit (ICU), sepsis continues to be an important and fatal diagnose with an ICU mortality rate around 20% [2]. The accompanying multiorgan failure (MOF) is often hard to cure. Moreover, the causative bacteria are getting increasingly resistant against antibiotics, together with surgical drainage of the infection site, the most important treatment modalities in sepsis.

So far, recent advances in knowledge of innate immunity have revealed that the infected patient produces its own antibiotics, antimicrobial peptides (AMPs). In vitro studies show possibilities to further refine such peptides to create new alternative drugs [3]. AMPs have also been shown to have cytokine-like effects [4] and could also affect the vasculature [5].

The circulatory disturbances resulting from the immense inflammatory activation during sepsis are central to the initial signs of the severe cases of the condition and have also been suggested to contribute to the development of the challenging complication, MOF. They include increased vascular permeability and subsequent leak, a process in which the endothelial glycocalyx may be involved [6, 7].

The resulting hypovolemia is often accompanied by vasodilatation, summing up to a treatment-refractory hypotension: septic shock. The vasodilation may be multifactorial, including vascular production of the vasodilator nitric oxide (NO) induced by cytokines and/or bradykinin.

In an attempt to elucidate the pathophysiology of circulatory collapse in sepsis. The present thesis focuses on different aspects of the interaction between inflammation and vascular regulation.

### **Endothelium**

The inside of the blood vessel is lined with a single layer of cells, the endothelium (Figure 1).



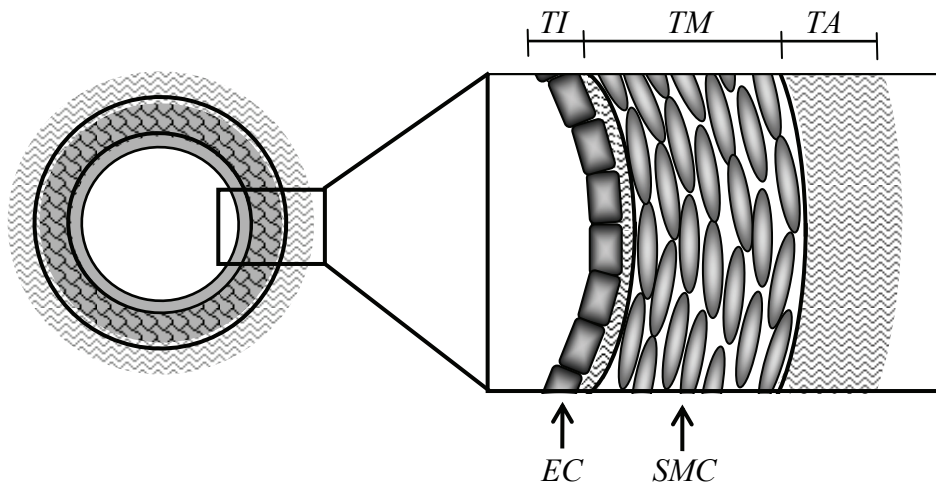

**Figure 1.** Schematic view of a blood vessel wall. Tunica *intima* (TI), tunica *media* (TM), tunica *adventitia* (TA), endothelial cells (EC) and smooth muscle cells (SMC). Printed by permission of Sara Moses, Gothenburg, Sweden.

The endothelial cells, facing the blood have vast effects on the regulation of the underlying smooth muscle cells (SMCs) and consequently, blood flow. The signaling between these two cell types includes endothelial release of NO and endothelium-derived hyperpolarizing factor (EDHF) [8, 9].

### *Nitric oxide*

NO is synthesized from L-arginine by the nitric oxide synthase (NOS) family enzymes. It is a short lived, highly diffusible lipophilic gas, relaxing smooth muscle and may thus contribute to the vasodilation seen in shock [10-12]. To inhibit the vasodilation mediated via of NO, L-N<sup>G</sup>-nitroarginine methyl ester (L-NAME), a non-selective and competitive NOS inhibitor, can be used [13].

### *Endothelium-derived hyperpolarizing factor*

EDHF, like NO, conveys an endothelial message to relax vascular smooth muscle cells (VSM) by means of increasing their membrane potential. The exact identity of EDHF is not known [14] but the vasodilatory effect can be

inhibited by increasing the potassium ion concentration, thereby inhibiting the hyperpolarization [15].

### *Glycocalyx, proteoglycans and glycosaminoglycans*

Endothelial proteoglycans (PGs) form the glycocalyx, a carbohydrate-rich zone on the luminal cell surface. PGs are composed of a core protein with covalently attached glycosaminoglycans (GAGs), unbranched polysaccharides displaying a negative electric charge due to abundant sulphate groups (Figure 2). GAGs are structurally heterogeneous and based on the monosaccharides involved they can be grouped into keratan sulphate, chondroitin/dermatan sulphate, heparan sulphate or heparin [16]. Glycocalyx is important in regulating vascular permeability, endothelial interactions with immune cells and anticoagulation, all mechanisms involved in sepsis [17]. In addition, GAGs inhibit the antibacterial activity of many AMPs and are present in high concentrations in chronic wounds [18].

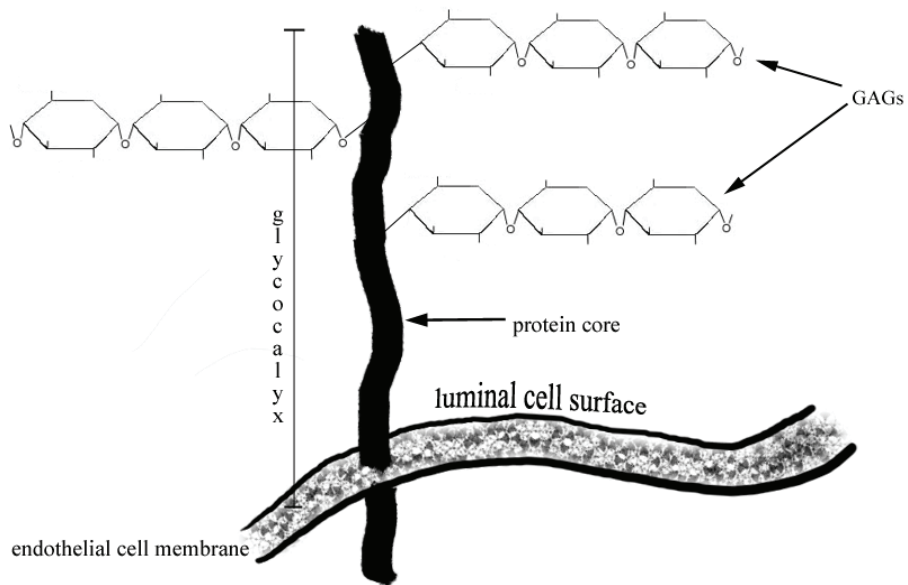

**Figure 2.** A proteoglycan consists of a protein core, in this case anchoring the molecule to a cell membrane, with attached glycosaminoglycans (GAGs), negatively charged, structurally heterogeneous polysaccharides. Illustration by Erik Hulteen.

## *Syndecan-1*

Syndecan-1 is a chondroitin and heparan sulphate PG present on the surface of many different celltypes [19, 20]. Experiments show that syndecan-1 is shed from the endothelium during inflammation [6]. It is, however, not known whether this is the case also during sepsis. Shedding of GAG-rich molecules on subsequent higher levels in plasma could have bearing on the efficacy of the innate immunity response in sepsis since free GAGs in chronic wounds have been shown to bind and inhibit the actions of AMPs [21].

## **White blood cells**

There exist five types of white blood cells or leukocytes, all originating from the hematopoietic stem cells in the bone marrow: neutrophils, eosinophils, basophiles, lymphocytes and monocytes. The neutrophils are the most frequent ones, making up 50-60% of total white blood cell count (WBC).

## *Neutrophils*

Neutrophils are commonly referred to as polymorphonuclear (PMN) leukocytes, which also comprises the less abundant basophiles and eosinophils, due to the multilobed nucleus, which appears like multiple nuclei. The cytoplasm includes granules, such as azurophil, specific and gelatinase granules with different contents of enzymes, proteins, AMPs, etc [22]. Upon neutrophil activation granule content is released. In this work contents from the azurophil and specific granules have been studied.

*Myeloperoxidase (MPO)* is a peroxidase enzyme with a heme pigment (which causes the green colour of secretions rich in neutrophils such as pus), and size of 140 kDa. MPO is composed of two heavy subunits of 53 kDa and two light subunits of 15 kDa. MPO is abundantly present in the azurophilic granules of the neutrophils. MPO, is not primarily acting as AMP but is released into the extracellular medium where its levels can be used as an index of neutrophil activity [23].

## Antimicrobial peptides and proteins

The antimicrobial substances presented in the following are heterogeneous by means of their size. Whether they should be referred to as peptides, polypeptides or proteins depends on their size as outlined in Table 1.

**Table 1.** Definition of peptide, polypeptide and protein [24].

<i>Numbers of amino acid/s of 20 naturally occurring</i>	
amino acid	one
dipeptide	two
tripeptide	three
oligopeptide	< 30
polypeptide	> 30
protein	polypeptides arranged in primary to quaternary structure

AMPs are the organism's own "broad spectrum antibiotics". AMPs exist naturally on epithelial linings such as the skin, epithelium of lungs, intestines, etc., but also in body fluids such as seminal plasma and breast milk. AMPs protect us from microbial invasion, and if it still occurs, they are in the first line of the immune system. AMPs thus constitute an important part of the innate or non-specific immune system. AMPs are in general small (less than 100 amino acids (aa) long), cationic and amphipathic with the amino acid chain often arranged in an  $\alpha$ -helix [25, 26]. Thus, the AMPs bind to the negatively charged bacterial cell wall via hydrophobic as well as electrostatic interactions [27].

Three groups of "classical" AMPs in humans are defined:

- cathelicidins; the peptide LL-37, which is the only human cathelicidin.
- defensins; of subgroups  $\alpha$  and  $\beta$ . In general,  $\alpha$ -defensins are expressed by blood cells such as neutrophils and stored in their azurophilic granules while the  $\beta$ -defensins are found on epithelium linings.
- histatins; the antimicrobial activity of which is mainly directed against fungi.

Several other AMPs have been identified such as peptides produced due to activation of the complement and contact systems [28, 66]. There are also larger polypeptides, displaying antimicrobial activity such as lactoferrin and bactericidal/permeability-increasing protein (BPI).

LL-37 is stored in the specific granules of neutrophils as the preprotein hCAP-18 (Table 2). Upon release, hCAP-18 is cleaved to LL-37, the active AMP, possessing broad spectrum activity against Gram-positive (G+) and Gram-negative (G-) bacteria, and fungi [3, 4, 29]. LL-37 is a 37 aa long highly cationic antimicrobial peptide, that may contribute to host defence also by acting on the lipoxin A<sub>4</sub> receptor (FPRL1, ALX), a G-protein-coupled receptor, to attract neutrophils by chemotaxis [30]. This receptor was originally called formyl peptide receptor-like 1 (FPRL1) due to its resemblance to the formyl peptide receptor (FPR) responsible for the chemotactic response to the bacterial compound formyl-methionyl-leucyl-phenylalanine (fMLP). One of the endogenous ligands for FPRL-1 is lipoxin A<sub>4</sub>. This prompted the International Union of Pharmacology to propose that this receptor should be officially named ALX [31]. ALX is therefore used in the present thesis although FPRL1 is still in use, mainly by immunologists. LL-37 also shows other biological effects such as stimulating angiogenesis [5] and neutralizing lipopolysaccharides (LPS), strong inducers of inflammation shed from bacterial wall [32]. Endothelial receptors for LL-37 suggest that LL-37 may in addition take part in regulating the vascular smooth muscle tonus and consequently blood flow.

**Table 2.** Antimicrobial peptides and proteins (AMPs) in human neutrophil azurophil and specific granules[22].

<i>Azurophil granules</i>	<i>Specific granules</i>
Heparin-binding protein	hCAP-18/LL-37
Bactericidal/permeability-increasing protein	Lactoferrin
Myeloperoxidase	
Defensins	

*Alpha-defensins (HNPI-3)*

Alpha-defensins, HNP 1-4, are 29-30 aa long peptides, highly abundant in the azurophil granules of the neutrophils (Table 2), as well as in macrophages and Paneth cells of the small intestine. The three principal human defensins, HNP 1-3, account for 99% of the total defensin content of neutrophils [33]. Apart from a broad antimicrobial spectrum, alpha-defensins attract several types of

immune cells including immature dendritic cells and may therefore serve as a link between innate and adaptive immunity [34].

### *Bactericidal/permeability-increasing protein (BPI)*

BPI is a 50 kDa cationic protein of 456 aa residues present in the azurophilic granules of neutrophils (Table 2). BPI is rapidly released by neutrophils in response to bacteria. BPI also binds and neutralizes soluble LPS. BPI induce bacterial killing and was the first identified “killing-protein” from neutrophils [35, 36].

### *Heparin-binding protein (HBP)*

HBP, also known as CAP37 or azurocidin is a 37 kDa heparin-binding and antimicrobial protein. HBP is released from azurophilic granules (Table 2) and secretory vesicles of neutrophils but is also present to a minor extent in the plasma membrane [37]. The ability of neutrophils to secrete HBP, and maybe other proteins, from secretory vesicles, could be important for proinflammatory functions of this and other neutrophil proteins. For example, HBP has been suggested to increase vascular permeability [37-39].

### *Lactoferrin*

Lactoferrin is an antimicrobial iron-binding protein with a molecular weight of 80 kDa, found in mammalian milk, tears, saliva and seminal plasma but also in neutrophils where it is the dominated stored protein in the specific granules (Table 2) [40]. Studies suggest lactoferrin contributing to the activation of innate immune system as well as to the adaptive one [41].

## **Contact system**

The human contact system, also known as the kallikrein-kinin system, is comprised of four plasma proteins: a cofactor, high-molecular-weight kininogen (HK), together with the serine proteinases factor XII, plasma kallikrein, and factor XI [42]. Upon activation, HK is cleaved, releasing the pro-inflammatory peptide bradykinin (Figure 3). The effects of bradykinin and its metabolite, des-arg<sup>9</sup>-bradykinin are vasodilation, increased vasopermeability and proinflammatory activities; all mechanisms participating in septic shock

where they may contribute to host defence [43-45]. Clear evidence for the importance of contact system in the pathophysiology of sepsis is, however, still lacking. Previously, measurements have hardly ever been performed of the levels of the direct effector, bradykinin, but only indirectly of HK, PPK, FXII, FXI and their inhibitors. However, in the 70's O'Donell and co-workers showed increased bradykinin levels in parallel to the severity of Gram-negative, hypotensive sepsis. Recently, in a minor study from Mattsson and co-workers, elevated bradykinin levels in *Staphylococcus aureus* septicaemia was found [46, 47]. More extensive studies need to be done also comparing levels of indirect effectors of the contact system to the direct effector, bradykinin [43-46, 48].

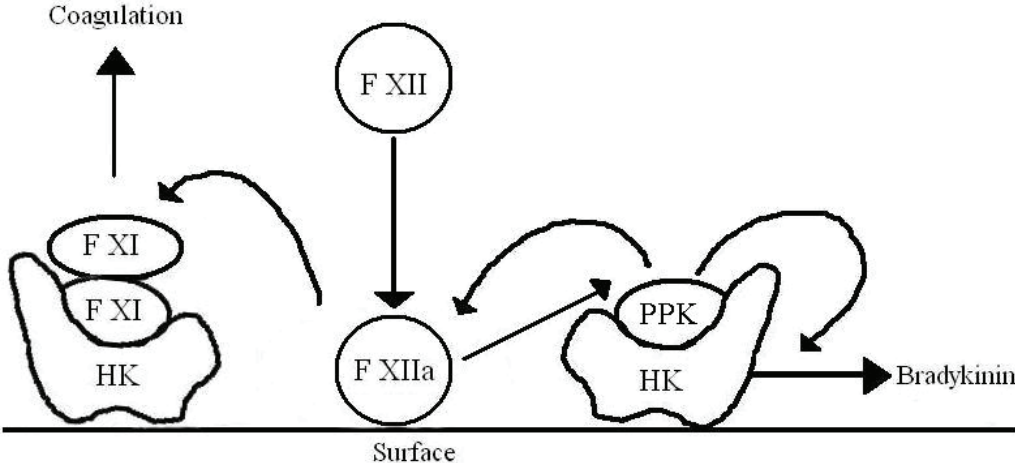

**Figure 3:** Schematic model of the contact system. Upon activation, for example by microbial components or artificial surfaces; Hageman factor (FXII) is activated, in turn activating FXI and plasma prekallikrein (PPK) resulting in activation of blood coagulation and release of bradykinin by cleavage of high-molecular-weight kininogen (HK). Illustration by Erik and Felix Hulsteen.

## **AIMS OF THE STUDIES**

The present studies were undertaken to:

Investigate if the antimicrobial peptide, LL-37, could affect vascular tone.

Investigate if plasma levels of GAGs and syndecan-1 are altered in septic patients, and if there is a correlation to mortality and circulatory disturbances.

Compare the plasma concentrations of a wide range of AMPs in septic patients with controls and correlate to the level of mortality, circulatory disturbances and inflammatory activation.

Challenge the view that bradykinin is clinically important in established severe human sepsis.



## **MATERIALS AND METHODS**

For details on the material and methods used in the present studies, the reader is referred to the separate papers. The Research Ethics Committee of the University Hospital of Lund approved the studies.

### **Preparation of human omental artery and vein**

Macroscopically normal segments of human omental arteries and veins (0.5-1.5 mm in diameter) were obtained from patients undergoing abdominal surgery. Exclusion criteria included patients with endocrine tumours and abdominal infections. The vessel segments were immediately dissected free from fat and connective tissue and then stored in aerated Krebs-Ringer solution (KRS) at 4°C until the experiments were performed (within 24 hours).

### **Measurement of smooth muscle force**

The vessel segments were cut into 2-4 mm long ring segments, and placed into 2-ml organ baths. The temperature in the baths was thermostatically maintained at 37°C and the KRS was continuously aerated with a gas mixture containing O<sub>2</sub> 92% and CO<sub>2</sub> 8% at a rate giving pH 7.4. The segments were rigged on two steel rods through the lumen. One of the rods was attached to a force displacement transducer for measurement of isometric force (Figure 4). Six segments in separate organ baths with KRS were run in parallel. To obtain optimal pretension, the vessel segments were gradually stretched to a stable resting force of 6 mN during an equilibration period of 60–90 min [49]. Next, KCl (final concentration 83 mM) was added and the resulting contraction was registered, in order to obtain an internal contraction standard for each segment. Subsequently, the KCl was washed out by repetitive changes of the KRS during which the contraction was allowed to return to baseline. Endothelin-1 (ET-1, 1 nM) was added and the resulting contraction was recorded. If required, the ET-1 concentration was increased stepwise until the contraction was equal to 70-130% of the contraction induced by 83 mM KCl. Next, substance P (SP) was added (final concentration 100 nM) and the resulting relaxation recorded. In intact segments, substance P induces a relaxation corresponding to around 80% of precontraction. The endothelium was regarded as damaged, if SP did not induce a relaxation.

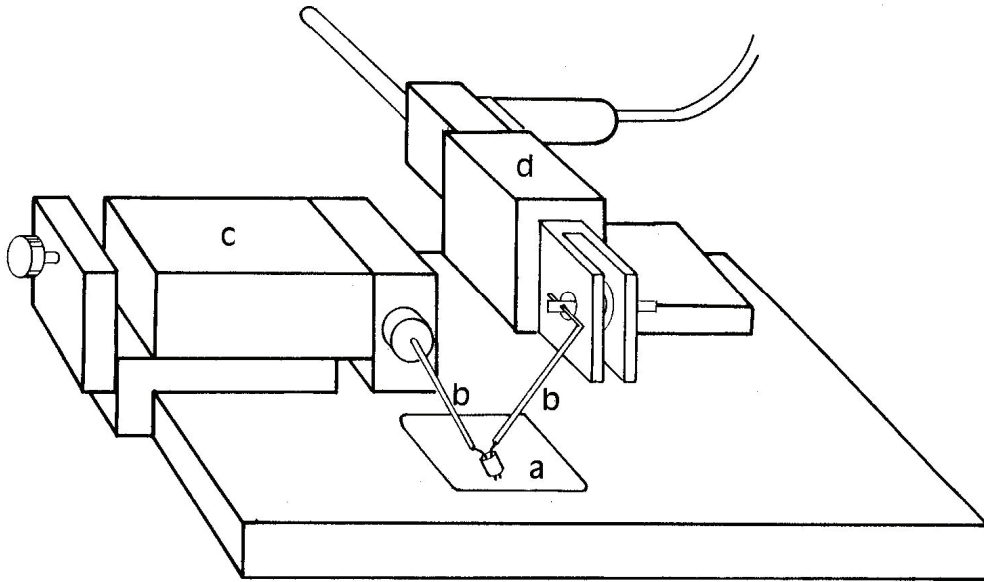

**Figure 4.** Schematic drawing of the myograph used in the present studies. Organ bath, 2 ml (a). Metal holders, diameter 0.1 mm (b) connected to screw (c) for lateral displacement. Fixed metal holder connected to force-displacement transducer (d).

#### *Effects of LL-37 or WKYMVm*

After thorough washout, ET-1 was added at the same concentration as preceding the addition of substance P and the resulting contraction recorded. When a stable contraction was achieved, LL-37 or WKYMVm (WKY) were added cumulatively, in the absence or presence of the ALX receptor antagonist WRWWW (WRW4). The resulting relaxation was recorded at each LL-37 or WKY concentration.

#### *Effects of LL-37 in vessel segments with endothelium removed*

In another series of experiments, the endothelium was removed in three of the six vein segments by gentle injection of the O<sub>2</sub>/CO<sub>2</sub> gas mixture through the vessel lumen. To confirm that the endothelium had been removed successfully, SP was added to the vessel segments precontracted with ET-1. The organ baths were then rinsed several times and relaxations in response to LL-37 were assessed as described above.

### *Involvement of prostanoids, NO or EDHF*

The relative contribution of prostanoids, NO, and EDHF to the LL-37-induced relaxation in vein segments were assessed in relaxation experiments in the presence of the nitric oxide synthase inhibitor, L-NAME, KCl at 30 mM concentration, which prevents hyperpolarization of the vascular smooth muscle, or the cyclooxygenase inhibitor, indomethacin.

## **Reverse transcriptase–polymerase chain reaction**

### *RNA isolation*

Pieces of omental veins, about 40 mm long, were rinsed in sterile KRS and cut in half. One of the halves was maintained intact whereas the other was cut open and the luminal side gently wiped with a sterile cotton swab and rinsed in KRS. The vessel segments, with and without endothelium, were separately submerged in trizol and homogenized mechanically. Isolation of RNA was carried out and cDNA synthesized.

### *Qualitative assessment*

Primer-specific segments of the cDNA were amplified in polymerase chain reaction. The PCR products were electrophoretically separated on an agarose gel containing ethidium bromide for UV detection. Primers for ALX and glyceraldehyde-3-phosphate dehydrogenase (GAPDH) were used. GAPDH is a housekeeping gene expressed in all cells and was used to confirm an equal RNA yield between the separate vessel segments.

### *Quantitative assessment (Real-time PCR)*

Gene expression assays for ALX, von Willebrand factor, and 18S rRNA were performed. The amount of ALX and von Willebrand factor products was normalized to the 18S rRNA product. The von Willebrand factor is constitutively expressed in the endothelium and was used to assess the success of endothelial removal. 18S rRNA is present in all cells.

## ICU patients

All consecutive patients admitted to the intensive care unit (ICU) of Lund University Hospital, Sweden, because of suspicious infection and who fulfilled of at least two out of four SIRS criteria (see Table 3) were included. For definitions of sepsis, severe sepsis or septic shock used in the present thesis please see Table 4.

**Table 3.** Criteria of Systemic Inflammatory Response Syndrome (SIRS) [50].

Body temperature	< 36°C or > 38°C
Heart frequency	> 90 beats/minute
Respiratory frequency	20 breaths/minute or P <sub>a</sub> CO <sub>2</sub> < 4.3 kPa or ventilator treatment
WBC	> 12 or < 4.0 (10 <sup>9</sup> / l)

Severity of the organ dysfunction was defined using the Sequential Organ Failure Assessment (SOFA) score (see Table 5) on the basis of measurements in the first 24 h of admission. Patients who had received heparin/heparin-like drugs were excluded. The mortality rate within 90 days after inclusion was registered.

**Table 4.** Definition of sepsis, severe sepsis and septic shock as used in the present studies.

	<i>SIRS</i>	<i>Infection: verified or suspected</i>	<i>Organ failure: circulation and/or respiration</i>	<i>Arterial hypotension: requiring inotropic and/or vasopressor therapy</i>
<i>Sepsis</i>	Yes	Yes		
<i>Severe sepsis</i>	Yes	Yes	Yes	
<i>Septic shock</i>	Yes	Yes	Yes	Yes

**Table 5.** Sequential Organ Failure Assessment (SOFA) score system as used in present studies [51].

<i>Score (points)</i>	<b>0</b>	<b>1</b>	<b>2</b>	<b>3</b>	<b>4</b>
<b>Respiration</b>					
<i>PaO<sub>2</sub>/FiO<sub>2</sub> (kPa)</i>	> 53	41 - 53	28 - 40	14 - 27	≤ 13
<b>Coagulation</b>					
<i>Platelet count (x 10<sup>9</sup>/l)</i>	> 150	101 - 150	51 - 100	21 - 50	≤ 20
<b>Liver</b>					
<i>Bilirubin (μmol/L)</i>	< 20	20 - 32	33 - 101	102 - 204	> 204
<b>Cardiovascular</b>					
<i>Hypotension (MAP, mmHg)</i>	≥ 70	< 70			
<i>Dopamin (μg/kg/min)</i>			≤ 5	> 5	> 15
<i>Dobutamin</i>			any dose		
<i>Noradrenaline (μg/kg/min)</i>				≤ 0.1	> 0.1
<b>CNS</b>					
<i>RLS</i>	1	2	3	4 - 5	> 5
<b>Kidney</b>					
<i>Creatinin (μmol/l)</i>	< 110	110 - 170	171 - 299	300 - 440	> 440
<i>or diuresis (ml/day)</i>				or < 500	or < 200

Comments: The score can vary between 0-24 points per registration. The six variables (respiration, coagulation, liver, cardiovascular, CSN, kidney) scores summarize every day. The worst score is registered.

## **Control patients**

The controls consisted of patients scheduled for surgery of an intracranial tumour at the Neurosurgery Department, Lund University Hospital, Sweden. None of the control patients had ongoing angiotensin converting enzyme inhibitor treatment, steroid treatment or had been given heparin/heparin-like drugs.

## **Blood samples**

Within 24 h after admission to the ICU, blood samples were drawn from an already existing arterial catheter and collected in citrate-treated and EDTA-treated plastic vacuettes. In some patients, additional blood samples were obtained 4 days later. Arterial blood samples from the control patients were similarly drawn before induction of anaesthesia. The samples were immediately centrifuged and the plasma supernatant was removed and stored at  $-80^{\circ}\text{C}$  until analysis.

### *Measurements of procalcitonin, C-reactive protein and white blood cell count*

Concentration of C-reactive protein (CRP) and white blood cell count (WBC) were determined by standard methods at the Clinical Chemistry Department at our hospital. The concentration of procalcitonin in citrate plasma was measured using an immunoluminometric assay kit.

### *Measurement of total protein*

The concentration was determined by reduction of  $\text{Cu}^{2+}$  to  $\text{Cu}^{+}$  by the peptide bonds of the polypeptides in an alkaline solution (the biuret reaction). The  $\text{Cu}^{+}$  formed was then detected by a reagent containing bicinchoninic acid yielding a purple colour quantified by spectrophotometry.

### *GAG assay*

Isolation and detection of sulfated GAGs from plasma was performed using a commercially available kit. The samples were added to an acidulous buffer rendering all macromolecules neutral or positively charged except GAGs. A cationic coloring agent (Alcian blue) was added and left to precipitate with the

negatively charged GAGs. The precipitate was captured by a dot-blot procedure on a membrane and measured with densitometry.

### *ELISA assays*

Levels of bradykinin, syndecan-1, BPI, HBP, HNP1-3, lactoferrin, LL-37, interleukins (IL) -6 and -10, and MPO were measured in EDTA plasma by commercially available enzyme-linked immunosorbent assay (ELISA) kits.

### *High-molecular-weight kininogen Western blot*

Proteins were separated by gel electrophoresis and transferred onto polyvinylidene difluoride (PVDF) membranes. Immunoprinting of the transferred proteins was done with a primary antibody detected by chemiluminescence using a peroxidase-conjugated secondary antibody. Intensity of the 120 kDa bands corresponding to HK was determined with densitometry and was normalized to a standard plasma sample run in each gel.

### **Radial diffusion assay**

To assess the ability of GAGs to interfere with the antibacterial activity of human plasma and isolated AMPs, a radial diffusion assay (RDA) was used. Venous blood from healthy donors was drawn and plasma was collected after centrifugation. *Escherichia coli* isolates were grown overnight. The bacterial suspension was mixed with agarose poor in nutrients and poured into Petri-dishes. A series of wells were punched in the plates after the agarose had solidified. Plasma samples, LL-37 or bactericidal/permeability-increasing protein (BPI) in the absence or presence of chondroitin sulphate (CS)-A, CS-B, CS-C, or heparin with or without diethylaminoethyl (DEAE)-Dextran were applied to the wells. Plates were incubated for 3 h. An overlay agarose rich in nutrients was then poured over, and the plates were incubated again to visualize growth of bacterial colonies. Antibacterial activity was indicated by a clear zone corresponding to the lack of bacterial growth around the wells. The diameter of the clear zone surrounding the wells was measured with a metric scale.

## **Statistical analysis**

Due to indications that several of the measurements in patient plasma were not normally distributed, these were evaluated using non-parametric methods: Wilcoxon signed rank test, Mann-Whitney U-test and Spearman rank correlation. In these cases values are given as medians followed by 25<sup>th</sup> and 75<sup>th</sup> percentiles. The results from the laboratory experiments were normally distributed and were analyzed with parametric tests such as Student's t-test. These results are given as means and SD or SEM as indicated. When means from more than two groups were to be compared or when more than one factor was to be considered, analysis of variance (ANOVA) was performed. Significance level:  $P < 0.05$ .



## RESULTS AND DISCUSSION

### Effects of LL-37 in vascular control

Human omental vessels constitute a well-characterized tissue for physiological and pharmacological investigations and were used in paper I [49, 52, 68]. LL-37, at submicromolar concentrations, induced a concentration- and endothelium-dependent relaxation in vein but not in artery segments precontracted by endothelin-1 (Figure 5 and Figure 6). The relaxation was profoundly reduced by potassium chloride (30 mM final concentration) to inhibit endothelium-derived hyperpolarizing factor (EDHF), whereas it was less affected by the NOS inhibitor, L-NAME (Figure 7) and not at all by indomethacin. This indicates that the relaxation involved endothelial release of EDHF and nitric oxide. The ALX agonist, WKY, also induced a relaxation and both the relaxations induced by LL-37 and WKY were inhibited by the ALX antagonist, WRW4.

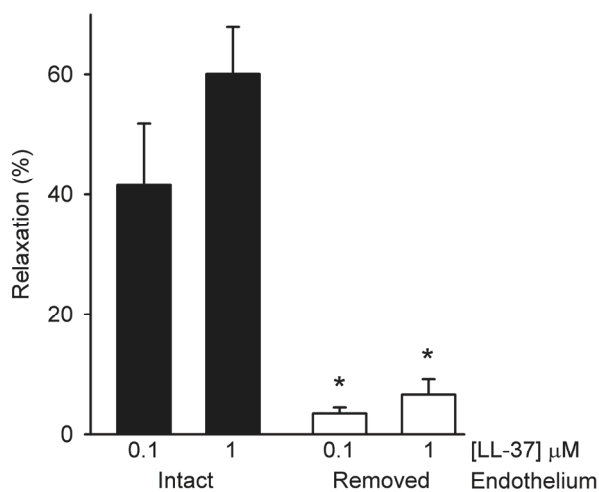

**Figure 5.** Endothelium dependency of the relaxation induced by LL-37 in isolated human omental vein segments precontracted by a submaximal concentration of ET-1. The LL-37-induced relaxation was markedly reduced after removal of the endothelium (\*). Values are means+SEM,  $n = 5$ .

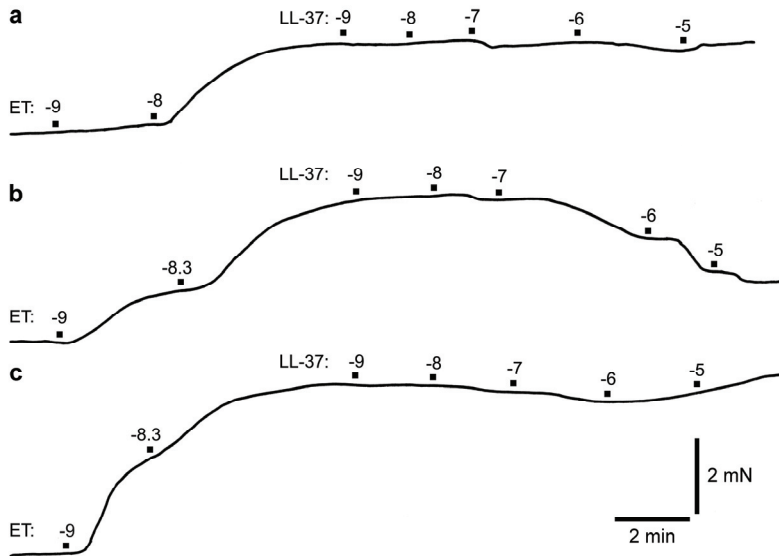

**Figure 6.** Representative recorder tracings illustrating the effect of LL-37 on isolated human omental artery (A) and vein segments (B and C) precontracted with ET-1 (ET). Log molar concentrations are indicated. LL-37 induced no or only weak relaxations in the artery segments (A). In vein segments with intact endothelium, LL-37 induced a relaxation (B), while no, or only weak relaxations were induced in endothelium-denuded segments (C).

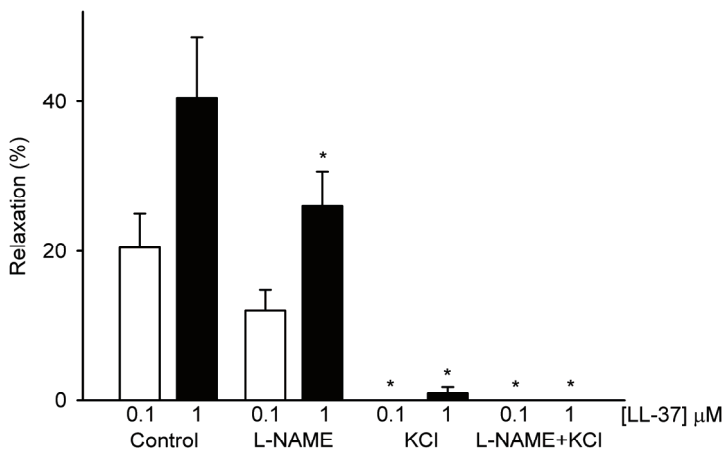

**Figure 7.** Relaxation induced by LL-37 in isolated segments of human omental vein precontracted by a submaximal concentration of endothelin-1 in the absence or presence of L-NAME, KCl or both. L-NAME inhibited the LL-37-induced relaxation by about 30% whereas KCl nearly abolished the LL-37-induced relaxation. Values are means + SEM,  $n = 8 - 11$ . \*indicates statistically significant difference from control.

The potency of WRW4 for inhibiting WKY and LL-37 induced relaxation in the present experiments was similar to that previously found for WRW4 inhibiting ALX-mediated  $\text{Ca}^{2+}$  mobilization and cell migration [53]. This indicates that the LL-37-mediated relaxation in the isolated human omental vein was mediated via ALX, which was further supported by the fact that the relaxation was induced by LL-37 in the same concentration range that induces ALX-mediated leucocyte chemotaxis [30]. Furthermore, the RT-PCR analysis demonstrated ALX expression in the vein endothelium in the presently used preparation.

This cardiovascular action of LL-37 presently demonstrate that this antimicrobial peptide could be a link between innate immunity and cardiovascular control. The physiological, pathophysiological or both, relevance of the present finding is unclear. LL-37 preprotein, hCAP-18, is released from activated leucocytes [54] and is then cleaved by simultaneously secreted proteinase 3 generating LL-37 [4]. Mean plasma concentrations of hCAP-18/LL-37 immunoreactivity in healthy individuals have been reported to be in the range 70-300 nM depending on whether hCAP-18 or LL-37 or a mixture accounted for the immunoreactivity [55].

In paper III we found a median plasma level of LL-37 around 15 nM in controls, which is lower by approximately an order of magnitude. The reason for this is not clear, but could be due to different antibodies employed that could have different cross-reactivity between hCAP-18 and LL-37. Still, the concentration correspond to the threshold concentration for LL-37 inducing relaxation found in the present study. This means that only a moderate increase in LL-37 concentration would suffice to induce a vascular response. Sepsis includes the degranulation of leucocytes [56] but our results in paper III suggest that this does not increase the LL-37 concentration in the circulation.

There is, however, also the possibility that blood vessels could respond to a local increase in LL-37. During an inflammatory response, granulocytes interact with the vascular endothelium, first rolling along in the vessel lumen. This is followed by granulocyte activation and degranulation, which could lead to a local increase in LL-37 concentrations allowing for the activation of endothelial ALX [57]. A subsequent relaxation of underlying smooth muscle, vasodilation and reduction of blood flow velocity and sheer stress could facilitate leukocyte adhesion and transmigration through the vessel wall. The

present results suggested that LL-37 could be a mediator of leukocyte-induced vasomotion. We could only demonstrate LL-37 induced relaxation in vein segments. The reason for this is not clear but it cannot be caused by a loss of viability of the arterial specimens as both potassium chloride and ET-1 contracted and substance P relaxed the smooth muscle. It should be noted, however, that leukocyte-vascular wall interactions mainly take place on the venous side of the circulation [58]. The results are summarized in figure 8.

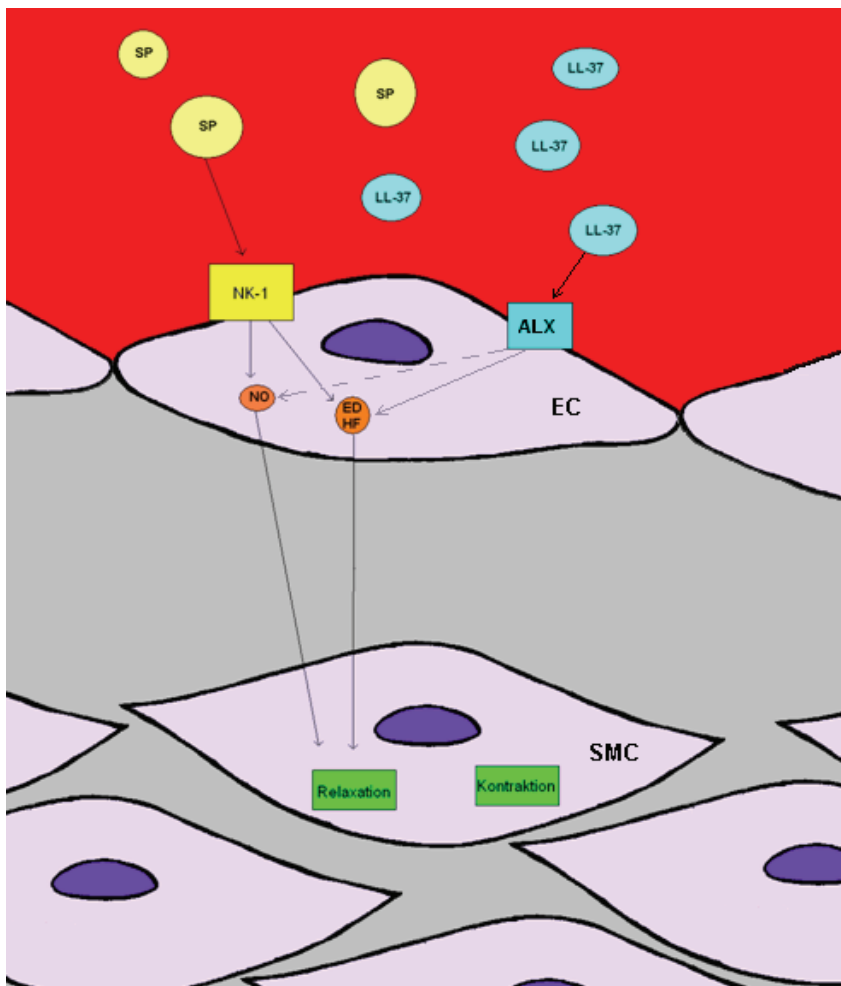

**Figure 8.** Endothelium-dependent relaxation of smooth muscle. Substance P (SP) acts on the neurokinin-1 (NK-1) receptor on the endothelial cell (EC), nitric oxide (NO) and endothelium-derived hyperpolarizing factor (EDHF) are released and give a relaxing effect on the smooth muscle cell (SMC). The present results showed that LL-37 is able to do the same, acting on lipoxin A<sub>4</sub> receptor (ALX) with exception that the NO-mediated relaxation was rather weak. Illustration by Erik Hulsteen.

## Glycosaminoglycans in sepsis and immunity

In our population of patients suffering from sepsis, the median plasma GAG level was significantly higher compared to matched controls (Figure 9, Paper II).

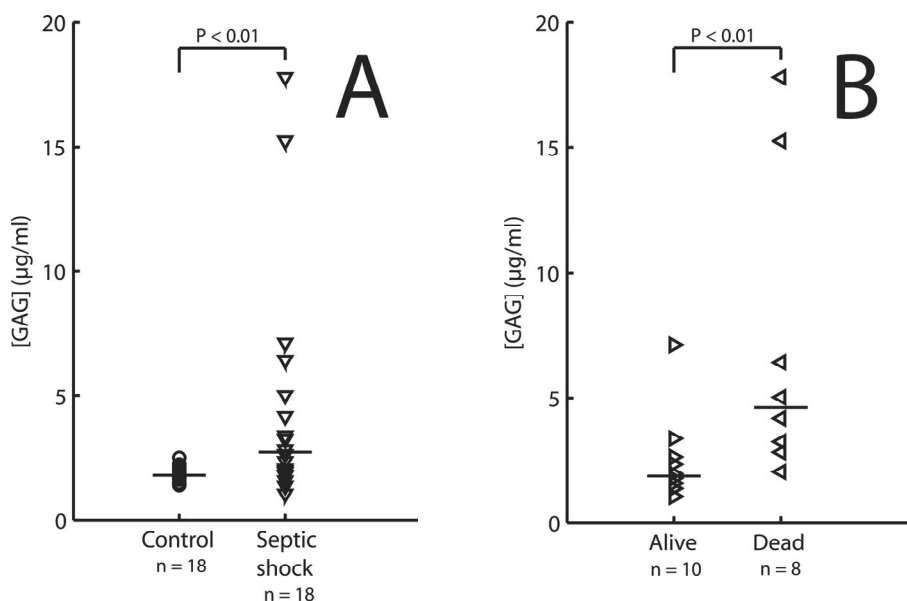

**Figure 9.** Plasma GAG level in septic shock patients and controls. The median GAG level was significantly higher in sepsis patients ( $\nabla$ ) compared with controls ( $\circ$ , A). Among the septic shock patients, the median GAG level was significantly higher in the patients who died within 90 days postsubmission ( $\triangleleft$ ) compared with the survivors ( $\triangleright$ , B). The median is indicated (horizontal line), and the symbols represent individual patients.

The mechanism of GAG metabolism resulting in increased levels is unknown. A possible explanation is that GAG has been shed from the glycocalyx of the endothelium which was confirmed by the increased levels of syndecan-1, which, as mentioned before, is an endothelial membrane PG. Other possible explanations could be decreased plasma clearance of GAGs due to failing kidney or liver function, which would be an interesting field for study. However, contradictory, the GAG levels correlated neither with creatinine nor bilirubin levels. It seems unlikely that syndecan-1 is the sole cause of the elevated GAG levels, since the plasma content of syndecan-1 was considerably lower than the total GAG content.

Moreover, a positive correlation was found between total GAG concentration and mortality, but not between syndecan-1 and mortality and no correlation was to be found between total-GAG and syndecan-1 levels. Considering that circulatory disturbances are a major problem in septic shock, it was interesting to note that the increased syndecan-1 level was actually positively correlated to cardiovascular SOFA score.

Another source of the high GAG levels could be neutrophils. In paper III, the neutrophil activity was estimated by measurement of levels of MPO. Some of the patients included in that study were also included in the GAG study and levels of MPO and GAGs could be measured in arterial blood collected at the same time point. These patients did not show any correlation between MPO and GAG, but interestingly between GAG and HBP ( $P = 0.0011$ ,  $n = 20$ ), another protein from the azurophilic granules. Simply demonstrating a correlation does not mean that there is a release of GAGs in connection with degranulation of neutrophils. It could just as well be a third factor taking part, for example inflammatory activation, which could cause neutrophil degranulation as well as GAG release elsewhere. *In vivo* studies have shown that disruption of glycocalyx is associated with subendothelial edema suggesting a link to vascular permeability and circulatory disturbances [59]. Baranska-Rybak and co-workers have shown that GAGs can bind AMPs and neutralize their antibacterial actions [21]. In line with this, we found that GAGs, at concentrations present in sepsis patients, inhibited the antibacterial activity of plasma as well as isolated AMPs *in vitro*. This suggests that the increased levels of GAGs could undermine innate immunity by binding locally or systematically released AMPs.

### **Levels of AMPs in severe sepsis**

AMPs, such as LL-37 are important for an effective innate immune system [60], which is heavily activated in sepsis. Our results demonstrated that LL-37, originating from the specific granules of neutrophils, could participate in vasodilation via an interaction with endothelial receptors (paper I). Furthermore, increased levels of BPI in sepsis patients have in previous studies been found to correlate with mortality [61, 62]. This awoke the idea of collecting plasma from sepsis patients. Maybe there could be a correlation between the levels of different AMPs, infectious agent, intensity of inflammatory activation, circulatory disturbances, and/or mortality. In the 31 sepsis patients scoring for total SOFA and cardiovascular SOFA indicating organ failure and circulatory derangement, levels of AMPs as well as

inflammatory mediators were measured (Paper III). Elevated CRP and procalcitonin as well as cytokine levels (IL-6 and IL-10) confirmed inflammatory activation (Table 6).

**Table 6.** Arterial levels of inflammatory parameters, cytokines and antimicrobial peptides. Data presented as median [25<sup>th</sup>-75<sup>th</sup> percentiles]. *n* = number of patients.

	<i>control</i>	<i>sepsis</i>	<i>day 0 at ICU</i>	<i>day 4 at ICU</i>	<i>alive</i>	<i>dead</i>
<i>n</i>	23-25	29-31	10-11	10-11	17-19	12
Lactoferrin (ng/ml)	12 [5.5-56]	159* [83-424]	116 [87-211]	101 [64-187]	129 [87-311]	201 [106-298]
LL-37 (ng/ml)	62 [44-86]	50 [32-114]	48 [34-70]	66 [56-90]	70 [30-127]	46 [38-62]
BPI (ng/ml)	5.6 [3.7-7.5]	19* [11-34]	27 [21-34]	3.0† [1.9-5.6]	16 [8.6-26]	28‡ [18-39]
Defensins (pg/ml)	0 [0-25]	73* [47-111]	71 [50-74]	54 [42-78]	74 [58-111]	65 [43-85]
Heparin-binding protein (ng/ml)	8.1 [7.9-8.3]	10* [9.7-13]	10 [9.8-13]	8.4† [8.2-8.9]	10 [9.5-11]	11 [9.7-13]
Myeloperoxidase (ng/ml)	53 [48-62]	255* [148-469]	430 [282-517]	130† [97-179]	255 [154-469]	281 [127-462]
Interleukin-6 (pg/ml)	0.5 [0.3-0.9]	2302* [602-7276]	3785 [1033-9992]	97† [27-225]	1936 [627-4248]	6179‡ [867-16396]
Interleukin-10 (pg/ml)	3.6 [2.0-4.9]	126* [35-306]	131 [103-299]	14† [11-23]	116 [34-236]	147 [85-328]
Procalcitonin (ng/ml)	0.012 [0.0075-0.028]	39* [4.5-86]	35 [4.1-85]	4.7† [0.34-12]	25 [5.6-68]	46 [4.1-92]
C-reactive protein (mg/ml)	N.D.	196 [123-264]	N.D.	N.D.	219 [193-335]	161 [82-210]
White blood cell count (10 <sup>9</sup> /l)	N.D.	12 [2.7-19]	N.D.	N.D.	12 [2.7-19]	12 [5.4-20]

\* Statically significant difference from control.

† Statically significant difference from value at day 0 at ICU.

‡ Statically significant difference from value for survivors.

N.D. Not determined

MPO was measured in an attempt to assess the activation of neutrophils. BPI, HBP, HNP 1-3 and lactoferrin but not LL-37, were elevated in sepsis patients, and levels of all AMPs, except LL-37, correlated positively to circulatory disturbances as graded with cardiovascular SOFA score. BPI levels did correlate with mortality with lower levels in survivors and the levels of most inflammatory markers and AMPs had at day 4 decreased compared to at inclusion at the ICU.

The levels of most AMPs correlated to the levels of MPO suggesting neutrophils as the main source of AMPs in the circulation. The levels of most AMPs correlated with the levels of IL-10 but not IL-6. This could be due to the fact that the measurements were made in plasma collected within the first 24 h in ICU and that many sepsis patients at that stage had already suffered from the condition for several days. It is probable that in these patients, the IL-6 levels had already passed their peak in favour of later appearing cytokines such as IL-10 [63].

Taken together, these results mainly confirm previous findings. The most interesting finding might be the absence of any alteration in LL-37 levels in sepsis patients despite that the increased lactoferrin levels suggest release of neutrophil specific granule content. In paper II we demonstrated that LL-37 binds to GAG. Sepsis patients were found to have higher GAG levels than controls. It can therefore be speculated that a larger fraction of plasma LL-37 is bound to GAG in these patients. This could block the epitopes of LL-37 important to recognition by the antibodies employed in the LL-37 ELISA. Pilot experiments demonstrated, however, that addition of GAGs at relevant concentrations did not affect the recovery of the ELISA. Furthermore, both GAG levels and levels of LL-37 were measured in 20 patients and there was neither a positive nor a negative correlation between the two parameters. We could not find any correlation between levels of AMPs and infectious agents (Table 7), which may be due to the limited material.

**Table 7.** Infectious agent found in blood culture from the sepsis patients. Note that a positive blood culture was obtained in only 16 out of 31 patients.

Infectious agent	Gram + / Gram -	Number of patients
<i>Escherichia coli</i>	Gram -	5
<i>Streptococcus pneumoniae</i>	Gram +	4
Enterococci	Gram +	3
Coagulase-negative staphylococci	Gram +	2
<i>Pseudomonas</i> species	Gram -	1
Enterobacter species	Gram -	1



## Contact system activation in severe sepsis/septic shock

The contact system is a cascade system of enzymes in the blood, which upon activation produce bradykinin by cleavage of the precursor HK. Bradykinin increases vessel permeability and is an effective vasodilator, and has therefore been proposed as an actor in the innate immune system and in the pathophysiology of septic shock [42, 64, 65]. Contact system activation also yields antimicrobial peptides, which would be beneficial in fighting the microbes [66]. The patients in Paper IV represents a group with severe sepsis and circulatory disturbances and therefore in need of intensive therapy at the ICU. Based on the literature, demonstrating contact system activation in sepsis patients, one would expect high levels of bradykinin but only a few studies have presented actual bradykinin levels and the results are inconclusive (please see background). As expected we found a lower level of HK in sepsis patients compared to controls, indicating contact system activation and subsequent HK consumption (Figure 10).

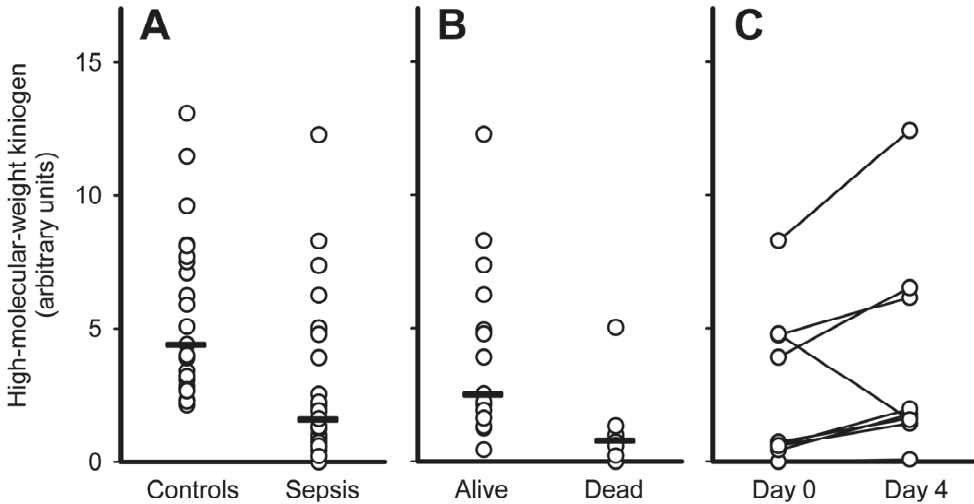

**Figure 10.** Plasma levels of high-molecular-weight kininogen (HK) in sepsis patients and controls. The median HK level was significantly lower in sepsis patients ( $n = 25$ ) compared with controls (A,  $P < 0.001$ ,  $n = 23$ ). Among the sepsis patients, the median HK level was significantly lower in the patients who died within 90 days post submission ( $n = 10$ ) compared to the survivors (B,  $P = 0.003$ ,  $n = 15$ ). At day 4 there was no statistically significant difference between median HK level compared to at inclusion (C,  $n = 9$ ).

The HK levels did not differ statistically significantly four days later compared to at inclusion although all but one patient had restored levels. HK levels at inclusion were lower in non-survivors than survivors and negatively correlated to severity of circulatory derangement. Taken together this clearly shows that the contact system was more heavily activated in the most affected patients. Our findings of lowered levels of bradykinin in these patients are therefore notable (Figure 11). The most plausible explanation is that in these patients, the contact system is depleted and lacking substrate, due to a process that has gone far already before the patient enters the ICU ward. Therefore, as already suggested [67] therapy aiming at damping the contact system activation in this patient group would probably be ineffective.

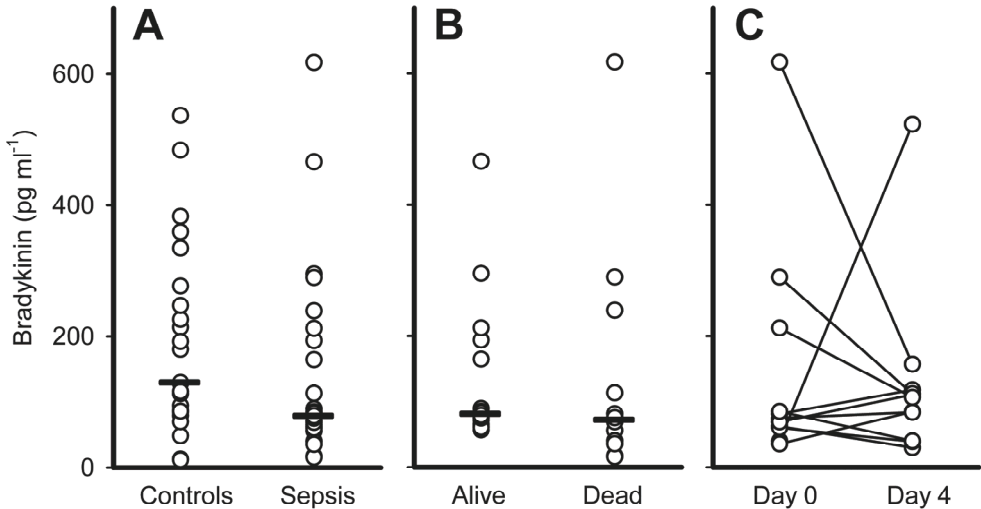

**Figure 11.** Plasma levels of bradykinin in sepsis patients and controls. The median bradykinin level was significantly lower in sepsis patients ( $n = 29$ ) compared with controls (A,  $P < 0.025$ ,  $n = 25$ ). There was no statistically significant difference in median bradykinin levels between surviving and dead sepsis patients (B) or at day 4 compared to at inclusion (C). The median is indicated with a horizontal line, and the symbols represent individual patients.

## CONCLUSIONS

The human antimicrobial peptide, LL-37, induces endothelium-dependent relaxation in human omental veins mediated via the endothelial receptor ALX. The relaxation involves the release of nitric oxide and EDHF but not prostanoids. LL-37 released from white blood cells could thus contribute to blood vessel dilatation during sepsis and treatment with ALX antagonists might be successful.

Plasma levels of GAG and syndecan-1 are increased in septic shock patients and the GAG level correlates to mortality. GAG, at concentrations present in the sepsis patients with a poor prognosis, inhibits plasma antimicrobial activity in vitro. The high levels of GAG could therefore be harmful to these patients by undermining the effectiveness of innate immunity.

Plasma levels of several AMPs, but not LL-37, are increased in patients with severe sepsis and correlate to circulatory derangement. This probably reflects neutrophil activation as a part of an innate immune response.

Within 24 hours after admission to ICU, plasma levels of bradykinin are decreased in patients with severe sepsis compared to controls. Low HK concentrations suggest previous contact system activation, which can explain the decrease in bradykinin levels due to substrate depletion. This challenges the role of bradykinin in the pathophysiology of severe sepsis.

## POPULÄRVETENSKAPLIG SAMMANFATTNING

Sepsis, eller blodförgiftning, är ett högst allvarligt tillstånd med en påtaglig inflammation i hela kroppen som svar på en infektion. Blodkärlens väggar blir som ”säll” och ökar därmed genomsläpligheten, inte bara för vätska, utan även för partiklar av olika storlek och dignitet. Av detta följer svårigheter att upprätthålla ett tillräckligt blodtryck och därmed att säkerställa syrgastillförseln till kroppens olika organ, vilket i sin tur bidrar till den utmaning narkosläkaren ställs inför då patienten kommer till intensivvårdsavdelningen (IVA).

Trots långvarig och intensiv forskning, som gett ökad kunskap om sjukdomens orsak och förlopp och därmed tillgång till förbättrad medicin och teknik, är dödligheten i blodförgiftning alltså hög. Man kan finna dödlighetstal som varierar mellan 25 % och 50 %. Det faktum att vi har en ökande motståndskraft hos bakterier mot antibiotika parallellt med att vi i ökad omfattning opererar in främmande material i våra kroppar, har gjort att de bakterier eller andra mikroorganismer som orsakar sjukdomen kan dyka upp i ny skepnad.

Den viktigaste behandlingsstrategin vid blodförgiftning är att ta på sig sin ”Sherlock Holmes-mössa” (lämna pipan därhän!) och finna den bakomliggande orsaken, alltså vilken mikroorganism är skyldig, och snarast påbörja rätt antibiotikabehandling. Olyckligtvis är mikroorganismer ibland ”hala små rackare” som vet att försvara sig, till exempel genom att ändra sitt utseende lite grann, och på så vis som redan nämnts, bli resistenta mot antibiotika. Men vår kropp är också någonting enastående fantastisk. I blodet finns ett slags celler, vita blodkroppar, som utgör en del av vår kroppens försvar. En särskild bataljon heter neutrofiler och har förmågan att tillverka kroppsegna bredspektrum-antibiotika, ”antimikrobiella peptider”, ”AMPs”. Att förstå mera om hur AMPs fungerar och regleras är något av en utmaning för forskarna men kan bli framtidens behandling av blodförgiftning.

I denna avhandling studeras huruvida LL-37, en slags AMP, förmår att slappa av blodkärlen och därmed bidra till det blodtrycksfall vi ser vid blodförgiftning. Vi fann att så var fallet och kartlade en del av mekanismerna som ligger bakom.

Likaså har man i tidigare studier av kroniska sår, sett en ökad nivå av ett slags sockerkedjor, glykosaminoglykaner, GAG, som även finns kärnväggen. Vi ville därför undersöka om liknande ökning kan tänkas finnas i blodet hos våra IVA-

patienter med blodförgiftning och om det i så fall kunde kopplas till allvarlighetsgraden och dödligheten i sjukdomen. Vi fann GAG vara klart förhöjd hos patienterna, särskilt hos dem som dog.

I en tredje studie mätte vi nivåer av olika AMPs, hos patienter med blodförgiftning, för att försöka finna en eventuell koppling till hur påverkad blodcirkulationen var eller till risken att avlida i sjukdomen. Studien bekräftade tidigare fynd.

Slutligen ville vi studera sepsispatienternas blodnivåer av bradykinin, som är en kraftigt verkande kroppsegen "käril-vidgare" och ansetts bidra till blodtryckssänkning. Man har tidigare visat att bradykinin aktiveras vid inflammation. Vi kunde inte uppmäta förhöjda nivåer bradykinin hos patienter med svår blodförgiftning, det vill säga patienter med påverkan på blodtryck. Vi menar därför att bradykinin sannolikt redan har spelat ut sin roll när patienten, som har blodförgiftning, har kommit till det stadium där blodcirkulationen är hotad.

## ACKNOWLEDGEMENTS

From the bottom of my heart, thank you

Anders for always being there.

Erik and Felix, you are my sunshines, no matter the colour of the sky.

Mikael Bodelsson alias Mike Tyson. Yes you are a boxer; quick, strong and creative, at least intellectually. But the best of all: You've let me discover the world of science in a way, the right way, just having fun. Die Deutsche Marschmusik is excused.

Axel Nelson, the one and only. You have helped me, encouraged me, taught me a lot; for example good music, how to decorate for Christmas and also some "lab-things". I do hope I can repay it somehow, and that we will continue our striving work together. All the best to you.

Thorgerdur Sigurdadottir, Tobba or Dr Toby. I do not know in which category to put you in: as a work mate, as my adaptive, as my co-laborator, as my travel-partner, as my friend. I put you in a special category: "the Tobba-category". I think you do not mind. Thank you Tobba, pussi-puss. I've never laughed as much as in Glasgow.

Dag Lundberg professor emeritus, for always being kind, having time, giving lots of good intelligent advices, and to give me the opportunity to work as "amanuens", the best job ever.

Professor PO Grände and present chairman Görel Nergelius for your commitment and for promoting and keeping up the excellent academic standards of our department.

Eva Ranklev-Tvetman, my former boss. A strong woman, with lots of humor, always encouraging and always "nära till ett skratt", an ideal in many ways.

Pia, Mina, Maria A, Malgorzata, Ole, Monica, Ing-Britt, Anita, Lasse, Heiko, Arthur, Victoria, Emma, Silla, Ulla, Oonagh, Annelie, Marcus, Pontus, Jacob...to name but a few wonderful people at B14, BMC. Matthias Mörgelin and Maria Baumgarten: I did not get any gold inside my book and I tried hard to get it on the outside, with some success. I'll be back!

Veronika Demmer-Selstam, “Vera”, thank you for always being my friend. All my love to you and your wonderful family.

Susanne Malander for all nice training-events, for all pep-talk, for pulling me around the lake Vättern twice! But there’ll be a third time, won’t it?

VIC-klubben, not frequent meetings but qualitative ones.

Agnetha Kulenovic-Nilsson, no meetings but telephone calls!

Marie Persson, “Lunken”, a friend to rely on from my childhood.

Christer Nilsson, consultant anaesthesiologist in Karlskrona, for generously allowing me to get my first experience of working in anaesthesia. You took absolutely good care of me, introduced me in the right way to the one and only speciality.

Magnus Hägerdahl and the late Leif Berntman who were chairman and vice-chairman at former “Anestesi-och intensivvårdskliniken” when I got my employment. I’ve enjoyed it here from the very first minute.

My room-mates Åsa Rudin (Åsa, thanks for good partnership as “amanuens”, all advices and I did survive the writing!), Malin Rundgren and Borit Bergsten. Peter Bansch my “amanuens-partner” (I owe you one beer at least!), Louise Walther - wish you the very best in your “amanuens”- and research-future. Katarina Levin, Ingrid Östlund, Johan Persson, John Jahr, Jan-Erik Kull...again to name but a few of all highly esteemed colleagues, nurses, assistant nurses, secretaries and mates at the best clinic “VIP-kliniken” in Lund, in Sweden, in Reality.

All nice, funny, intelligent, hard working medical students. I have indeed loved my time with you. I specially have to mention John Karlsson Valik and Ola Sörensen.

My parents Kjell and Kerstin, my brother Anders and my sister Anna-Lena for all our discussions, argues and love. Mum: I know that you at this very moment might be proud and I will not argue with you because of that. Thank you for being my mum.

Grandmother Ebba up in the sky or somewhere else. You are my absolutely best friend and my big idol. A hard-working woman, feminist, struggling and fighting all her life, did never give up until “the day” came.

## REFERENCES

1. Hotchkiss RS, Karl IE. The pathophysiology and treatment of sepsis. *N Engl J Med* 2003; 348: 138-150.
2. Vincent JL, Sakr Y, Sprung CL, Ranieri VM, Reinhart K, Gerlach H, Moreno R, Carlet J, Le Gall JR, Payen D. Sepsis in European intensive care units: results of the SOAP study. *Crit Care Med* 2006; 34: 344-353.
3. Sigurdardottir T, Andersson P, Davoudi M, Malmsten M, Schmidtchen A, Bodelsson M. In silico identification and biological evaluation of antimicrobial peptides based on human cathelicidin LL-37. *Antimicrob Agents Chemother* 2006; 50: 2983-2989.
4. Sorensen OE, Follin P, Johnsen AH, Calafat J, Tjabringa GS, Hiemstra PS, Borregaard N. Human cathelicidin, hCAP-18, is processed to the antimicrobial peptide LL-37 by extracellular cleavage with proteinase 3. *Blood* 2001; 97: 3951-3959.
5. Koczulla R, von Degenfeld G, Kupatt C, Krotz F, Zahler S, Gloe T, Issbrucker K, Unterberger P, Zaiou M, Lebherz C, Karl A, Raake P, Pfosser A, Boekstegers P, Welsch U, Hiemstra PS, Vogelmeier C, Gallo RL, Clauss M, Bals R. An angiogenic role for the human peptide antibiotic LL-37/hCAP-18. *J Clin Invest* 2003; 111: 1665-1672.
6. Mulivor AW, Lipowsky HH. Inflammation- and ischemia-induced shedding of venular glycocalyx. *Am J Physiol Heart Circ Physiol* 2004; 286: H1672-1680.
7. Aird WC. The role of the endothelium in severe sepsis and multiple organ dysfunction syndrome. *Blood* 2003; 101: 3765-3777.
8. Furchgott RF, Zawadzki JV. The obligatory role of endothelial cells in the relaxation of arterial smooth muscle by acetylcholine. *Nature* 1980; 288: 373-376.
9. Vanhoutte PM. How to assess endothelial function in human blood vessels. *J Hypertens* 1999; 17: 1047-1058.
10. Ignarro LJ, Buga GM, Wood KS, Byrns RE, Chaudhuri G. Endothelium-derived relaxing factor produced and released from artery and vein is nitric oxide. *Proc Natl Acad Sci U S A* 1987; 84: 9265-9269.
11. Palmer RM, Ferrige AG, Moncada S. Nitric oxide release accounts for the biological activity of endothelium-derived relaxing factor. *Nature* 1987; 327: 524-526.
12. Kirkeboen KA, Strand OA. The role of nitric oxide in sepsis--an overview. *Acta Anaesthesiol Scand* 1999; 43: 275-288.



13. Rees DD, Palmer RM, Schulz R, Hodson HF, Moncada S. Characterization of three inhibitors of endothelial nitric oxide synthase in vitro and in vivo. *Br J Pharmacol* 1990; 101: 746-752.
14. Taylor SG, Weston AH. Endothelium-derived hyperpolarizing factor: a new endogenous inhibitor from the vascular endothelium. *Trends Pharmacol Sci* 1988; 9: 272-274.
15. Zygmunt PM, Hogestatt ED. Role of potassium channels in endothelium-dependent relaxation resistant to nitroarginine in the rat hepatic artery. *Br J Pharmacol* 1996; 117: 1600-1606.
16. Lane DA, Lindahl U. Heparin. Edward Arnold, London; 1989.
17. Parish CR. The role of heparan sulphate in inflammation. *Nat Rev Immunol* 2006; 6: 633-643.
18. Schmidtchen A, Frick IM, Andersson E, Tapper H, Bjorck L. Proteinases of common pathogenic bacteria degrade and inactivate the antibacterial peptide LL-37. *Mol Microbiol* 2002; 46: 157-168.
19. Ala-Kapee M, Nevanlinna H, Mali M, Jalkanen M, Schroder J. Localization of gene for human syndecan, an integral membrane proteoglycan and a matrix receptor, to chromosome 2. *Somat Cell Mol Genet* 1990; 16: 501-505.
20. Alberts B et al. *The Cell*. 4<sup>th</sup> Edition. Garland Science, New York; 2002.
21. Baranska-Rybak W, Sonesson A, Nowicki R, Schmidtchen A. Glycosaminoglycans inhibit the antibacterial activity of LL-37 in biological fluids. *J Antimicrob Chemother* 2006; 57: 260-265.
22. Borregaard N, Cowland JB. Granules of the human neutrophilic polymorphonuclear leukocyte. *Blood* 1997; 89: 3503-3521.
23. Hampton MB, Kettle AJ, Winterbourn CC. Inside the neutrophil phagosome: oxidants, myeloperoxidase, and bacterial killing. *Blood* 1998; 92: 3007-3017.
24. Nationalencyklopedin, Höganäs, Sweden: Bra Böcker AB; 1995 pp. Volume 1, pp. 295-296, Volume 15, pp. 46, 308-310.
25. Boman HG. Antibacterial peptides: basic facts and emerging concepts. *J Intern Med* 2003; 254: 197-215.
26. De Smet K, Contreras R. Human antimicrobial peptides: defensins, cathelicidins and histatins. *Biotechnol Lett* 2005; 27: 1337-1347.
27. Zasloff M. Antimicrobial peptides in health and disease. *N Engl J Med* 2002; 347: 1199-1200.

28. Nordahl EA, Rydengard V, Nyberg P, Nitsche DP, Morgelin M, Malmsten M, Bjorck L, Schmidtchen A. Activation of the complement system generates antibacterial peptides. *Proc Natl Acad Sci U S A* 2004; 101: 16879-16884.
29. Turner J, Cho Y, Dinh NN, Waring AJ, Lehrer RI. Activities of LL-37, a cathelin-associated antimicrobial peptide of human neutrophils. *Antimicrob Agents Chemother* 1998; 42: 2206-2214.
30. De Y, Chen Q, Schmidt AP, Anderson GM, Wang JM, Wooters J, Oppenheim JJ, Chertov O. LL-37, the neutrophil granule- and epithelial cell-derived cathelicidin, utilizes formyl peptide receptor-like 1 (FPRL1) as a receptor to chemoattract human peripheral blood neutrophils, monocytes, and T cells. *J Exp Med* 2000; 192: 1069-1074.
31. Brink C, Dahlen SE, Drazen J, Evans JF, Hay DW, Nicosia S, Serhan CN, Shimizu T, Yokomizo T. International Union of Pharmacology XXXVII. Nomenclature for leukotriene and lipoxin receptors. *Pharmacol Rev* 2003; 55: 195-227.
32. Nagaoka I, Hirota S, Niyonsaba F, Hirata M, Adachi Y, Tamura H, Heumann D. Cathelicidin family of antibacterial peptides CAP18 and CAP11 inhibit the expression of TNF-alpha by blocking the binding of LPS to CD14(+) cells. *J Immunol* 2001; 167: 3329-3338.
33. Lehrer RI, Ganz T. Defensins of vertebrate animals. *Curr Opin Immunol* 2002; 14: 96-102.
34. Ayabe T, Satchell DP, Wilson CL, Parks WC, Selsted ME, Ouellette AJ. Secretion of microbicidal alpha-defensins by intestinal Paneth cells in response to bacteria. *Nat Immunol* 2000; 1: 113-118.
35. Weiss J, Victor M, Stendhal O, Elsbach P. Killing of gram-negative bacteria by polymorphonuclear leukocytes: role of an O<sub>2</sub>-independent bactericidal system. *J Clin Invest* 1982; 69: 959-970.
36. Weiss J, Elsbach P, Olsson I, Odeberg H. Purification and characterization of a potent bactericidal and membrane active protein from the granules of human polymorphonuclear leukocytes. *J Biol Chem* 1978; 253: 2664-2672.
37. Gautam N, Olofsson AM, Herwald H, Iversen LF, Lundgren-Akerlund E, Hedqvist P, Arfors KE, Flodgaard H, Lindbom L. Heparin-binding protein (HBP/CAP37): a missing link in neutrophil-evoked alteration of vascular permeability. *Nat Med* 2001; 7: 1123-1127.
38. Tapper H, Karlsson A, Morgelin M, Flodgaard H, Herwald H. Secretion of heparin-binding protein from human neutrophils is determined by its localization in azurophilic granules and secretory vesicles. *Blood* 2002; 99: 1785-1793.
39. Kahn R, Herwald H, Muller-Esterl W, Schmitt R, Sjogren AC, Truedsson L, Karpman D. Contact-system activation in children with vasculitis. *Lancet* 2002; 360: 535-541.

40. Weinberg ED. Human lactoferrin: a novel therapeutic with broad spectrum potential. *J Pharm Pharmacol* 2001; 53: 1303-1310.
41. de la Rosa G, Yang D, Tewary P, Varadhachary A, Oppenheim JJ. Lactoferrin acts as an alarmin to promote the recruitment and activation of APCs and antigen-specific immune responses. *J Immunol* 2008; 180: 6868-6876.
42. Colman RW, Schmaier AH. Contact system: a vascular biology modulator with anticoagulant, profibrinolytic, antiadhesive, and proinflammatory attributes. *Blood* 1997; 90: 3819-3843.
43. Pixley RA, DeLa Cadena RA, Page JD, Kaufman N, Wyshock EG, Colman RW, Chang A, Taylor FB, Jr. Activation of the contact system in lethal hypotensive bacteremia in a baboon model. *Am J Pathol* 1992; 140: 897-906.
44. Leeb-Lundberg LM, Marceau F, Muller-Esterl W, Pettibone DJ, Zuraw BL. International union of pharmacology. XLV. Classification of the kinin receptor family: from molecular mechanisms to pathophysiological consequences. *Pharmacol Rev* 2005; 57: 27-77.
45. Hack CE, Ogilvie AC, Eisele B, Eerenberg AJ, Wagstaff J, Thijs LG. C1-inhibitor substitution therapy in septic shock and in the vascular leak syndrome induced by high doses of interleukin-2. *Intensive Care Med* 1993; 19 Suppl 1: S19-28.
46. O'Donnell TF, Jr., Clowes GH, Jr., Talamo RC, Colman RW. Kinin activation in the blood of patients with sepsis. *Surg Gynecol Obstet* 1976; 143: 539-545.
47. Mattsson E, Herwald H, Cramer H, Persson K, Sjobring U, Bjorck L. Staphylococcus aureus induces release of bradykinin in human plasma. *Infect Immun* 2001; 69: 3877-3882.
48. Hirsch EF, Nakajima T, Oshima G, Erdos EG, Herman CM. Kinin system responses in sepsis after trauma in man. *J Surg Res* 1974; 17: 147-153.
49. Wallerstedt SM, Bodelsson M. Endothelium-dependent relaxation by substance P in human isolated omental arteries and veins: relative contribution of prostanoids, nitric oxide and hyperpolarization. *Br J Pharmacol* 1997; 120: 25-30.
50. American College of Chest Physicians/Society of Critical Care Medicine Consensus Conference: definitions for sepsis and organ failure and guidelines for the use of innovative therapies in sepsis. *Crit Care Med* 1992; 20: 864-874.
51. SIR. Svenska intensivvårds registret. <http://www.icuregswe.org/>
52. Thorlacius K, Zhoujun C, Bodelsson M. Effects of sevoflurane on sympathetic neurotransmission in human omental arteries and veins. *Br J Anaesth* 2003; 90: 766-773.

53. Bae YS, Lee HY, Jo EJ, Kim JI, Kang HK, Ye RD, Kwak JY, Ryu SH. Identification of peptides that antagonize formyl peptide receptor-like 1-mediated signaling. *J Immunol* 2004; 173: 607-614.
54. Larrick JW, Hirata M, Zhong J, Wright SC. Anti-microbial activity of human CAP18 peptides. *Immunotechnology* 1995; 1: 65-72.
55. Sorensen O, Cowland JB, Askaa J, Borregaard N. An ELISA for hCAP-18, the cathelicidin present in human neutrophils and plasma. *J Immunol Methods* 1997; 206: 53-59.
56. Bogar L, Tarsoly P, Jakso P. Characteristics of light and heavy polymorphonuclear leukocytes. *Clin Hemorheol Microcirc* 2002; 27: 149-153.
57. Joyce DE, Nelson DR, Grinnell BW. Leukocyte and endothelial cell interactions in sepsis: relevance of the protein C pathway. *Crit Care Med* 2004; 32: S280-286.
58. Nourshargh S, Marelli-Berg FM. Transmigration through venular walls: a key regulator of leukocyte phenotype and function. *Trends Immunol* 2005; 26: 157-165.
59. van den Berg BM, Vink H, Spaan JA. The endothelial glycocalyx protects against myocardial edema. *Circ Res* 2003; 92: 592-594.
60. Chromek M, Slamova Z, Bergman P, Kovacs L, Podracka L, Ehren I, Hokfelt T, Gudmundsson GH, Gallo RL, Agerberth B, Brauner A. The antimicrobial peptide cathelicidin protects the urinary tract against invasive bacterial infection. *Nat Med* 2006; 12: 636-641.
61. Rintala E, Peuravuori H, Pulkki K, Voipio-Pulkki LM, Nevalainen T. Bactericidal/permeability-increasing protein (BPI) in sepsis correlates with the severity of sepsis and the outcome. *Intensive Care Med* 2000; 26: 1248-1251.
62. Calvano SE, Thompson WA, Marra MN, Coyle SM, de Riesthal HF, Trousdale RK, Barie PS, Scott RW, Moldawer LL, Lowry SF. Changes in polymorphonuclear leukocyte surface and plasma bactericidal/permeability-increasing protein and plasma lipopolysaccharide binding protein during endotoxemia or sepsis. *Arch Surg* 1994; 129: 220-226.
63. Sewnath ME, Olszyna DP, Birjmohun R, ten Kate FJ, Gouma DJ, van Der Poll T. IL-10-deficient mice demonstrate multiple organ failure and increased mortality during *Escherichia coli* peritonitis despite an accelerated bacterial clearance. *J Immunol* 2001; 166: 6323-6331.
64. Cockcroft JR, Chowienczyk PJ, Brett SE, Bender N, Ritter JM. Inhibition of bradykinin-induced vasodilation in human forearm vasculature by icatibant, a potent B2-receptor antagonist. *Br J Clin Pharmacol* 1994; 38: 317-321.

65. Frick IM, Bjorck L, Herwald H. The dual role of the contact system in bacterial infectious disease. *Thromb Haemost* 2007; 98: 497-502.
66. Nordahl EA, Rydengard V, Morgelin M, Schmidtchen A. Domain 5 of high molecular weight kininogen is antibacterial. *J Biol Chem* 2005; 280: 34832-34839.
67. Fein AM, Bernard GR, Criner GJ, Fletcher EC, Good JT, Jr., Knaus WA, Levy H, Matuschak GM, Shanies HM, Taylor RW, Rodell TC. Treatment of severe systemic inflammatory response syndrome and sepsis with a novel bradykinin antagonist, deltibant (CP-0127). Results of a randomized, double-blind, placebo-controlled trial. CP-0127 SIRS and Sepsis Study Group. *Jama* 1997; 277: 482-487.
68. Steen S, Skärby TV, Norgren L, Andersson KE. Pharmacological characterization of postjunctional alpha-adrenoceptors in isolated human omental arteries and veins. *Acta Physiol Scand* 1984; 120: 109-116.