



LUND UNIVERSITY

Reducing Throttle Losses Using Variable Geometry Turbine (VGT) in a Heavy-Duty Spark-Ignited Natural Gas Engine

Kaiadi, Mehrzad; Tunestål, Per; Johansson, Bengt

Published in:
SAE Technical Paper Series

DOI:
[10.4271/2011-01-2022](https://doi.org/10.4271/2011-01-2022)

2011

[Link to publication](#)

Citation for published version (APA):

Kaiadi, M., Tunestål, P., & Johansson, B. (2011). Reducing Throttle Losses Using Variable Geometry Turbine (VGT) in a Heavy-Duty Spark-Ignited Natural Gas Engine. In *SAE Technical Paper Series* Society of Automotive Engineers. <https://doi.org/10.4271/2011-01-2022>

Total number of authors:
3

General rights

Unless other specific re-use rights are stated the following general rights apply:
Copyright and moral rights for the publications made accessible in the public portal are retained by the authors and/or other copyright owners and it is a condition of accessing publications that users recognise and abide by the legal requirements associated with these rights.

- Users may download and print one copy of any publication from the public portal for the purpose of private study or research.
- You may not further distribute the material or use it for any profit-making activity or commercial gain
- You may freely distribute the URL identifying the publication in the public portal

Read more about Creative commons licenses: <https://creativecommons.org/licenses/>

Take down policy

If you believe that this document breaches copyright please contact us providing details, and we will remove access to the work immediately and investigate your claim.

LUND UNIVERSITY

PO Box 117
221 00 Lund
+46 46-222 00 00

Reducing Throttle Losses Using Variable Geometry Turbine (VGT) in a Heavy-Duty Spark-Ignited Natural Gas Engine

Mehrzad Kaiadi, Per Tunestål, Bengt Johansson
Division of Combustion Engines, Lund University, Faculty of Engineering

Copyright © 2011 SAE Japan

Abstract

Stoichiometric operation of Spark Ignited (SI) Heavy Duty Natural Gas (HDNG) engines with a three way catalyst results in very low emissions however they suffer from bad gas-exchange efficiency due to use of throttle which results in high throttling losses.

Variable Geometry Turbine (VGT) is a good practice to reduce throttling losses in a certain operating region of the engine. VTG technology is extensively used in diesel engines; it is very much ignored in gasoline engines however it is possible and advantageous to use them on HDNG engine due to their relatively low exhaust gas temperature. Exhaust gas temperatures in HDNG engines are low enough (lower than 760⁰C) and tolerable for VGT material. Traditionally HDNG are equipped with a turbocharger with waste-gate but it is easy and simple to replace the by-pass turbocharger with a well-matched VGT.

By altering the geometry of the turbine housing, the area for exhaust gases can be adjusted and results in the desired torque. Because of this the turbo lag is very low and it has a low boost threshold. Low boost threshold means that VGT can cover a big operation range of the engine from low engine speeds to high. In this operation range the throttle can be fully open and VGT is used instead of the throttle to control the desired torque which results in eliminating the throttling losses.

This paper presents experimental results which show the feasibility of reducing throttling losses by means of VGT. The operating region which is appropriate for controlling the desired torque by VGT instead of throttle is specified. The gains in terms of gas exchange efficiency are quantified. Furthermore the dynamics of using VGT is quantified and compared with throttle. The experiments were performed successfully and the results showed at least 2 unit percent improvement in gas-exchange efficiency. A comparable dynamic to throttle is observed.

Introduction

Most of SI engines use a throttle to control the desired torque. The throttle losses results in lower gas-exchange efficiency which results in worse fuel economy [1]. Gas-exchange efficiency for the most of operating points of a HDNG engine is presented in Figure 1. As Brake Mean Effective Pressure (BMEP) at each engine speed decreases, the Gas-Exchange efficiency also decreases due to the more closed throttle which results in more pumping losses.

Some strategies have been reported to reduce the throttling losses. In [2], [3] and [4] Exhaust Gas Recirculation (EGR) is used together with closed loop dilution limit control to reduce the throttling losses. With this strategy the benefits are limited to the dilution limit of the engine. In [5] a technology called WEDACS (Waste Energy Driven Air Conditioning System) is being developed to recover throttling losses. In [6], [7] and [8] the new and efficient strategy viz. Variable Valve Timing (VVT) is introduced which resulted in higher efficiency in a wider range of operating region of engines. However these strategies associated with complexity, more components and higher costs.

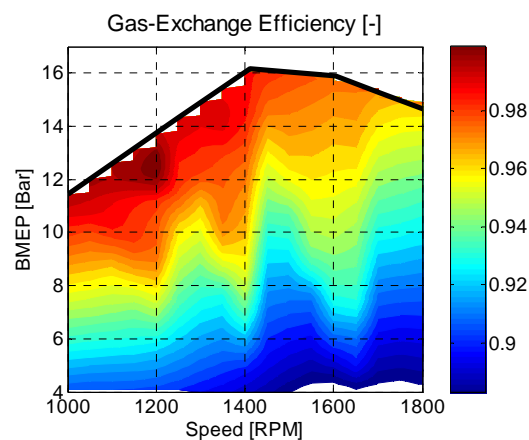

Figure 1: Gas-exchange efficiency as a function of Load and Engine speed for a HDNG engine

This paper presents an innovative strategy which shows how VGT can be used to partly reduce the throttling losses in a HDNG engine. In [9] the feasibility of using VGT for the HDNG engine is established. Moreover extending the maximum load limit of the engine by means of VGT was addressed and discussed.

VGT technology is extensively used in diesel engines however the use of VGT is very much ignored in gasoline engines due to their relatively high exhaust temperatures. The exhaust gas temperature of gasoline engines could reach up to 1000°C, versus 650°C in diesel engines [10]. Ordinary VGT materials and constructions are difficult to withstand temperatures over 890°C [11].

Normally natural gas engines use the same combustion technology as gasoline engines due to similar fuel properties. In heavy-duty applications, since the engine speed does not exceed 2000 RPM, the exhaust gas temperature is not very high. As an example, the maximum allowable exhaust gas temperature for the experimental engine that operates stoichiometrically is 7600C which is tolerable for VGT material. Traditionally heavy-duty natural gas engines use the same turbocharging technology as gasoline engines. They are equipped with a turbocharger with wastegate but it is quite simple and advantageous to replace the by-pass turbocharger with a well-matched VGT to achieve the required boost pressure.

Normally a throttle is used to control the desired torque in the engines, but it is also possible to use a VGT instead of the throttle in a large operating range to control the desired torque. This is possible due to the flexibility of the VGT to adjust the inlet pressure by altering the geometry of the turbine housing. In this operation region the throttle is kept fully open and the VGT is used to adjust the inlet pressure and finally control the demanded torque. This means that the throttle will not be used in a large part of the operating region and no throttle use means no throttle losses.

The boost threshold for the experimental engine is specified in Figure 2. VGT start producing boost only above the atmospheric pressure and with enough amount of exhaust mass flow rate. Figure 2 shows the inlet pressure as a function of different engine speed and BMEP after installing VGT on the engine. The VGT operating region is above the boost threshold and is specified with the dashed lines.

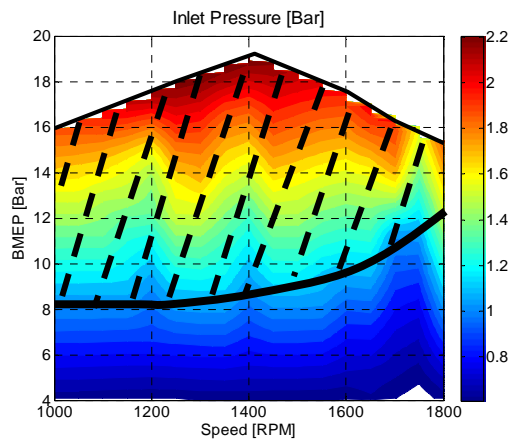

Figure 2: Inlet pressure as a function of Load and Engine speed for the HDNG engine equipped with VGT. Operating range with VGT is specified with the dashed lines

The main objective of this paper is to investigate the feasibility of reducing losses by means of VGT. The possible gains in term of gas exchange efficiency and fuel consumption is quantified. Moreover the dynamics of the VGT is compared to the throttle dynamic. The results showed that by using VGT instead of throttle in a big operating range the Gas-Exchange efficiency is

improved by at least 2 unit percent. The dynamics of VGT and throttle are compared and the reasonable dynamics by VGT is reported.

Experimental setup

In this section the specification of the experimental engine, its control system and the pressure measurements are described.

THE ENGINE

The experimental engine was originally a diesel engine from Volvo which has been converted to a natural gas engine, see Table 1 for the engine specification. The engine is equipped with high pressure and low pressure EGR system and also a turbocharger with wastegate.

Table 1: Specification of the engine

Number of Cylinder	6
Displacement	9,4 Liter
Bore	120 mm
Stroke	138 mm
Compression ratio	10,5 :1
Fuel	Natural gas

ENGINE CONTROL SYSTEM

A master PC based on GNU/Linux operating system is used as a control system. It communicates with three Cylinder-Control-Modules (CCM) for cylinder-individual control of ignition and fuel injection via Controller Area Network (CAN) communication, see Figure 3. The engine is equipped with Low and High pressure EGR system and a VGT.

Crank and cam information are used to synchronize the CCMs with the crank rotation. Flexible controller implementation is achieved using Simulink and C-code is generated using the automatic code generation tool of Real Time Workshop. The C-code is then compiled to an executable program which communicates with the main control program.

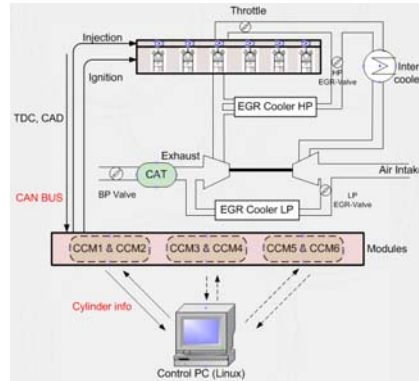

Figure 3: The test engine setup

PRESSURE MEASUREMENT

Each cylinder head is equipped with a piezo electric pressure transducer of type Kistler 7061B to monitor cylinder pressures for heat release calculations. Cylinder pressure data are sampled by a Microstar 5400A data acquisition processor.

Results

This section is divided into three main subsections. In the first subsection the possible gains with VGT in term of gas-exchange efficiency is discussed. The time constant of the system by using VGT or throttle is calculated and compared in the second subsection. In the third subsection the achieved results are validated by performing same experiments at other operation points.

Improvement in Gas-Exchange Efficiency

To quantify the gain in gas-exchange efficiency, IMEP was altered between 10 and 14 bar at 1000 RPM once by using the throttle and once by using the VGT. First the throttle is used to change the load. In this case the VGT position is fixed (i.e. 60% closed) and the throttle was altered between 40 and 100% opening to achieve the desired load. The results are evaluated in terms of gas-exchange efficiency (see Figure 4). The Y-axis to the left shows the throttle position and the Y-axis to right illustrate the gas-exchange efficiency. The X-Axis indicates the number of cycles. Once the throttle was fully opened, the gas-exchange efficiency increased from roughly 98 percent to almost 100 percent. It confirms that the throttling losses results in roughly 2 percent unit losses in gas-exchange efficiency at this operating point.

In the second experiment the throttle was kept fully open and the VGT is used to alter the desired load at the same engine speed. The VGT position is altered between 0 and 60% to adjust the desired boost and subsequently to achieve the desired IMEP. The load was altered in the same range as it was altered by the throttle. Figure 5 shows the gas-exchange efficiency as the VGT is used to control the load. The Y-axis to the left shows the VGT position and the Y-axis to right illustrates the gas-exchange efficiency. Since no throttling has occurred to adjust the desired

load, no losses are introduced and the gas-exchange efficiency is kept at its highest level all the time i.e. almost 100%. During the transient (i.e. step responses) some wave pulses are generated which result in overshoots in the opposite direction (see Figure 5). For instance when opening the VGT, exhaust backpressure decreases, but it takes a while before the inlet pressure falls, thus lower pumping loss and higher gas-exchange efficiency for some cycles can be achieved. In the same way higher pumping loss is achieved for some cycles when closing the VGT. The duration of these overshoots corresponds to the turbochargers lag at this operating point.

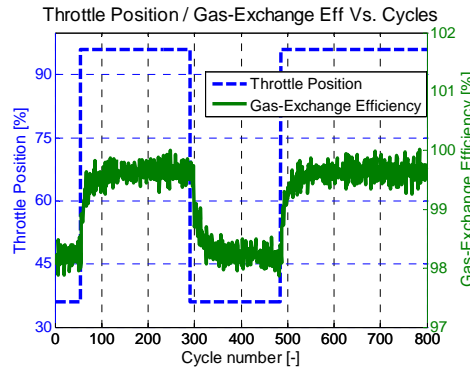

Figure 4 Gas-Exchange efficiency as throttle used to control the desired load at 1000 RPM

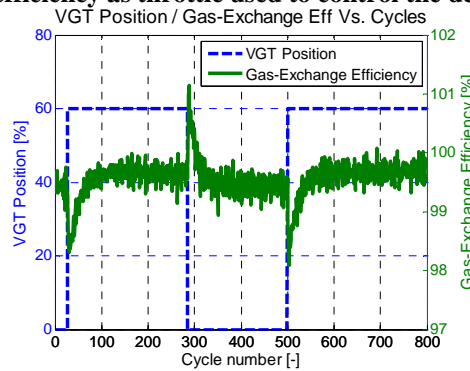

Figure 5 Gas-exchange efficiency as VGT used to control the desired load at 1000 RPM

Dynamics of VGT versus Throttle

Another important parameter that should be considered is the response time of the engine to the changes in VGT. The response time should be fast enough to make the VGT a viable alternative to the throttle. The time constants for the experiments i.e. load variation by VGT or throttle are calculated and compared. Time constant is defined as the time required for a system output to change from its previous state to 63% of the final settled value.

As discussed in the previous subsection, two different experiments were performed one with throttle and one with VGT. The results in terms of gas-exchange efficiency were evaluated and discussed. Figure 6 and Figure 7 show the rise and fall of IMEP in response to throttle or VGT

changes for the same experiments. The time constant during rise and fall of IMEP for both experiments are calculated and presented in Table 2.

The time constant for the system during the rise is somewhat longer with VGT but during the fall it is much shorter. The VGT was about 10 cycles slower in rising but almost 25 cycles faster in falling. 10 cycles corresponds to 1.2 seconds at 1000 RPM and 25 cycles corresponds to 3 seconds at 1000 RPM. These results indicate that the dynamics of the VGT are fast enough to be an alternative to the throttle.

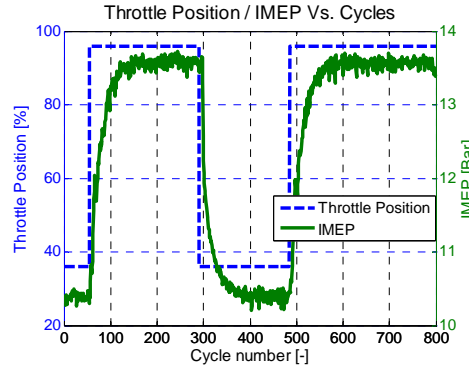

Figure 6 IMEP as Throttle used to control the desired load at 1000 RPM

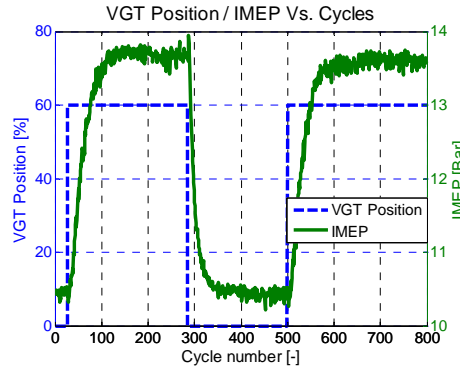

Figure 7 IMEP as VGT used to control the desired load at 1000 RPM

Table 2 Time constant of the system with Throttle and VGT

Sensor	Direction	Time Constant (Cycle)
Throttle	Rise	45
	Fall	60
VGT	Rise	55
	Fall	35

Validation

The previous experiments were performed at 1000 RPM and gains of about 2 percent units in gas-exchange efficiency were observed. According to Figure 1 the largest operating region of the VGT is at 1400 RPM. To validate the achieved results and also to investigate the VGT performance at some other operating points, the same experiments were performed at 1400

RPM. The IMEP was altered between 11 and 21 bar, once with the throttle and once with the VGT. Figure 8 and Figure 9 show the gas-exchange efficiency as the load was altered with the throttle and VGT respectively. The gas exchange efficiency decreases from approximately 98 % to 95 % when throttle is used to change the load (i.e. IMEP) from 21 to 11 bar at 1400 RPM. In the second experiment the throttle is kept fully open and the VGT is used to achieve the same amount of IMEP. As Figure 9 shows the gas-exchange efficiency is kept at its highest level all the time. This confirms 3 percentage points improvement in gas-exchange efficiency by using VGT instead of throttle at those operating points. The dynamics were also in the same range as reported for the 1000 RPM case. Similar experiments at other engine speeds were performed which were in line with the presented results.

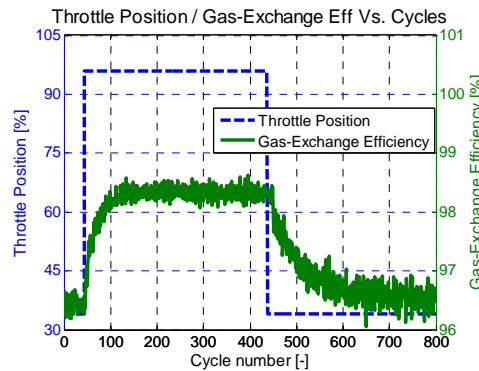

Figure 8 Gas-Exchange efficiency as throttle used to control the desired load at 1400 RPM

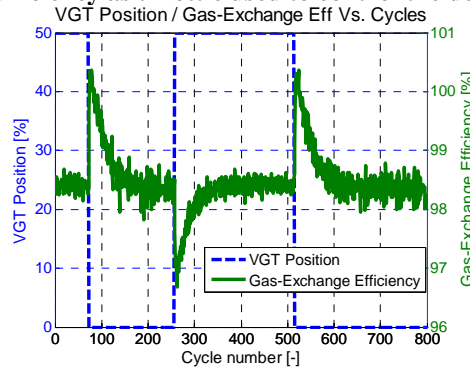

Figure 9 Gas-Exchange efficiency as VGT used to control the desired load at 1400 RPM

Control Strategy for Fuel-efficient driving (lowest possible throttle losses)

To avoid the throttling losses as much as possible a control strategy is suggested. It gives two options to the driver to control the desired load. The driver will be able to drive either in the conventional way i.e. with throttle or in a fuel-efficient mode. With the fuel-efficient strategy, the throttle usage is avoided as much as possible. With this mode, to control the load mainly VGT, partly EGR and partly a combination of throttle and EGR is used.

The whole operating region of the engine is divided into three main regions. The biggest operating region located above the boost threshold which can be covered by VGT. In this region as it was already discussed in this paper, the throttle is fully open and the load is totally controlled by altering the geometry of the turbine housing. This results in adjusting the boost pressure and finally the demanded load. This region is specified in Figure 10. 60 percent of the total operating points can be covered by VGT. The second region is located under the boost threshold. The throttle still can be fully open and by adding EGR the amount of load is decreased. This means that at this region the EGR valve is the main actuator for controlling the desired load. Since the throttle is still fully open at this operating region there will not be any throttle losses. There is a limit for the amount of EGR with the fully open throttle. Increasing in cyclic variation in IMEP can be a good indication for this limit. The throttle is used combined with the optimal amount of EGR in the third region. Figure 10 demonstrate the three discussed operating regions and Figure 11 describes the suggested control strategy.

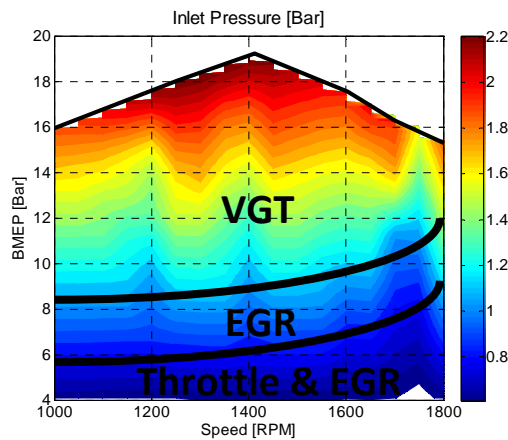

Figure 10: The economical driving requires different strategies at different operating regions.

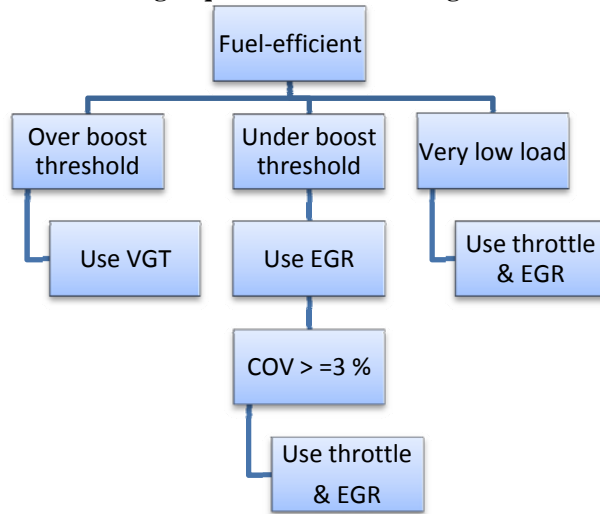

Figure 11: The suggested control strategy for fuel-efficient driving

Conclusion

An innovative strategy is suggested to reduce the throttling losses. This strategy uses VGT to control the desired load instead of throttle. Some experiments are designed and the performed. The following conclusions are obtained from this study

1. VGT is suggested to be used instead of throttle to control the load in a big operating area.
2. A comparison between VGT and throttle in term of gas-exchange efficiency is performed. The results showed at least two unit percent improvements in gas-exchange efficiency by using VGT.
3. The boost threshold of the engine is specified. VGT cover more than 60% of the total operating area of the engine.
4. The dynamics of VGT and throttle are compared. VGT was 10 cycles (i.e. 1.2 seconds at 1000 RPM) slower in raise and 25 cycles faster in fall (i.e. 3 seconds at 1000 RPM). These make VGT as a considerable alternative to throttle.
5. A control strategy is suggested to operate the engine with the lowest possible throttle losses.

Reference

1. Heywood John B., "Internal Combustion Engine Fundamentals", McGraw-Hill, 1988
2. I. Haskara, G. Zhu, Ch. Daniels, J. Winkelman. Closed loop maximum dilution limit control using in-cylinder ionization signal, SAE 2005-01-3751
3. M. Kaiadi, P. Tunestal, B. Johansson " Closed-Loop Combustion Control Using Ion-current Signals in a 6-Cylinder Port-Injected Natural-gas Engine" SAE 2008-01-2453
4. M. Kaiadi, P. Tunestal, B. Johansson" Closed-Loop Combustion Control for a 6-Cylinder Port-Injected Natural-gas Engine" SAE 2008-01-1722
5. R.H.L. Eichhorn, M.D. Boot, C.C.M. Luijten "Throttle Loss Recovery using a Variable Geometry Turbine" SAE 2010-01-1441
6. Alvon C. Elrod, Michael T. Nelson "Development of a Variable Valve Timed Engine to Eliminate the Pumping Losses Associated with Throttled Operation" SAE 860537
7. Allen J., Law D "Production Electro-Hydraulic Variable Valve-Train for a new Generation of I.C. Engines", SAE Paper Number 2002-01-1109, 2002.
8. D. Nehmer, L. Flueckiger, S. Bohac, C. Cowland, "Development of a Fully Flexible Hydraulic Valve Actuation Engine Part I: Hydraulic Valve Actuation System Development", Global Powertrain Congress, 2002
9. M. Kaiadi, P. Tunestal, B. Johansson "Improving Efficiency, Extending the Maximum Load Limit and Characterizing the Control-related Problems Associated with Higher Loads in a 6-Cylinder Heavy-duty Natural gas Engine" ASME, ICES2010-35012
10. R. Bosch GmbH "Automotive Handbook" Book, 6th edition, 2004

11. K. Miller "Turbo: Real-World High-Performance Turbocharger Systems (S-A Design)", 2004

12. Lennartson B. "Reglerteknikens Grunder" Holmbergs Malmö AB, Sweden 2008