



LUND UNIVERSITY

Channel Related Optimization of Wireless Communication Systems

Tufvesson, Fredrik

1998

[Link to publication](#)

Citation for published version (APA):

Tufvesson, F. (1998). *Channel Related Optimization of Wireless Communication Systems*. Lund University.

Total number of authors:

1

General rights

Unless other specific re-use rights are stated the following general rights apply:

Copyright and moral rights for the publications made accessible in the public portal are retained by the authors and/or other copyright owners and it is a condition of accessing publications that users recognise and abide by the legal requirements associated with these rights.

- Users may download and print one copy of any publication from the public portal for the purpose of private study or research.
- You may not further distribute the material or use it for any profit-making activity or commercial gain
- You may freely distribute the URL identifying the publication in the public portal

Read more about Creative commons licenses: <https://creativecommons.org/licenses/>

Take down policy

If you believe that this document breaches copyright please contact us providing details, and we will remove access to the work immediately and investigate your claim.

LUND UNIVERSITY

PO Box 117
221 00 Lund
+46 46-222 00 00

Channel Related Optimization of Wireless Communication Systems

Fredrik Tufvesson

Department of Applied Electronics

Lund University, Lund, Sweden

February 1998

Thesis for the degree of Licentiate in Engineering¹

¹ A Swedish university degree between M.Sc. and Ph.D.

© 1998 Fredrik Tufvesson

No. 3

ISSN 1402-8662

Printed in Sweden

Reprocentralen, Lund University

Lund 1998

Abstract

This thesis deals with different optimization problems in the design of wireless communication systems. It is mainly directed to the design of systems based on multicarrier techniques and orthogonal frequency division multiplex, OFDM, but some of the problems apply to single carrier systems as well.

The influence of different pilot patterns is analyzed when pilot symbol assisted modulation, PSAM, is used in OFDM systems. It is desirable to decrease the number of required pilot symbols and it is shown that the pilot pattern used plays a major role to enable reliable channel estimates from a small amount of pilot symbols. Rearrangement of the pilot pattern enables a reduction in the number of needed pilot symbols up to a factor 10, still retaining the same bit error performance.

The effect of the number of sub-channels used in an OFDM system is analyzed with respect to resulting bit error rate. An analytical expression for the bit error rate on Rayleigh fading channels when interchannel interference, ICI, caused by channel changes during a symbol and energy loss due to the cyclic prefix are regarded. This expression is used to optimize the number of sub-channels, and thereby the sub-channel bandwidth (sub-channel spacing) in the system. It is argued that the system can be optimized neglecting the effect of imperfect channel estimation and on a worst case assumption for the Doppler frequency and signal to noise ratio.

The benefits of using pre-compensation (precoding) in wireless time division duplex, TDD, systems are also investigated. The uplink channel estimate is used to compensate the channel impact on the downlink symbols. This enables less complex receiver structures in the mobile terminal since channel equalization is performed in the base station. Three different methods where amplitude and/or phase are adjusted are analyzed in terms of performance limits. Closed-form expressions for the QPSK bit error rate are given assuming a fully known channel. It is shown that pre-compensation is an attractive alternative to differential decoding. Phase-only compensation is preferred at low signal to noise ratios, while at high signal to noise ratios an order of magnitude improvement in the bit error rate can be obtained by including amplitude pre-compensation.

All the analyses and optimizations are general and can be applied to any OFDM system.

Key words: Radio communication, multicarrier, orthogonal frequency division multiplex, channel estimation, pilot symbol assisted modulation, sub-channel spacing, sub-channel bandwidth, interchannel interference, intersymbol interference, cyclic prefix, Rayleigh fading, pre-compensation, precoding, time division duplex.

Preface

This licentiate thesis relies on the work I have carried out during the first three years as a doctoral student at the Department of Applied Electronics. It comprises different aspects of my research area, radio channel problems in conjunction with Orthogonal Frequency Division Multiplex (OFDM) systems. The thesis consists of an introduction and a background to OFDM and the channel problems, a discussion, a summary and the papers listed below.

- Fredrik Tufvesson and Torleiv Maseng, "Pilot Assisted Channel Estimation for OFDM in Mobile Cellular Systems", Proceedings of IEEE Vehicular Technology Conference, Phoenix, U.S.A, pp. 1639-1643, May 4-7, 1997.
- Fredrik Tufvesson and Torleiv Maseng, "Optimization of sub-channel bandwidth for mobile OFDM systems", in D. Everitt and M. Rumsewicz, editors, Multiaccess, mobility and teletraffic – advances in wireless networks, pp. 103-114, Kluwer Academic Publishers, Dordrech, The Netherlands, 1998.
- Fredrik Tufvesson, Michael Faulkner and Torleiv Maseng, "Theoretical analysis of pre-compensation for Rayleigh fading channels in QPSK TDD systems", Series of technical reports, no. 3, ISSN 1402-8840, Department of Applied Electronics, Lund University, Lund, Sweden, January 1998.

The last paper is not directed to OFDM systems only, but these systems are good examples where the assumption of a flat slowly Rayleigh fading channel is met.

In addition to these papers I have written two conference papers that are not a part of the thesis:

- Fredrik Tufvesson and Torleiv Maseng, "On channel estimation strategies for a cellular OFDM system", Nordic Radio Seminar, Lund, Sweden, pp. 28-31, August 27-28, 1996.
- Fredrik Tufvesson, "Some channel estimation strategies for a cellular OFDM system", Proceedings of the RVK'96 RadioScience and Communication Conference, Luleå, Sweden, pp. 161-164, June 3-6, 1996.

Acknowledgement

I would like to thank all friends and colleagues at the Department of Applied Electronics for the help I have received during these first three years at the department. Especially I am very grateful to some of the people in the radio communications group, thank you Johan Hokfelt, Peter Malm, Ove Edfors and Anette Larsson for valuable help and interesting discussions. This work is supervised by Professor Torleiv Maseng. Without his help, sense and gut feeling for mobile communications it could not have been done at all. I would also like to say thanks to Mike Faulkner, who has inspired me with an enthusiasm that never dries up.

Finally, I am very grateful to Petra who has encouraged me all the time and to all of my friends who have distracted me during the same period.

Financial support has been received from NUTEK (The Swedish National Board for Industrial and Technical Development).

Contents

1	Introduction	1
2	Background	3
2.1	The radio channel	3
2.1.1	Reflections	3
2.1.2	Transfer function	5
2.1.3	Coherence time and coherence bandwidth	6
2.2	Single- or multicarrier systems?	7
2.2.1	Examples of practical systems	8
2.3	OFDM	8
2.3.1	Cyclic prefix	9
2.3.2	Sub-channel bandwidth	10
2.3.3	Transmission models	11
2.3.4	Differential vs. coherent detection	11
2.4	Channel estimation	13
2.4.1	Pilot symbol assisted modulation	14
2.4.2	Channel estimation in GSM	15
2.4.3	Channel estimation in DVB	16
2.4.4	How to design a pilot pattern	17
2.5	Pre-compensation	19
2.5.1	TDD systems	20
2.5.2	Channel compensation	21
2.5.3	TDD in DECT	22
A	Some specifications of OFDM systems	23

VIII

3 Paper summary	25
4 Discussion	27
4.1 New mobile communication systems	27
4.2 Future work	28
Bibliography	29

Paper I

Pilot assisted channel estimation for OFDM in mobile cellular systems

Paper II

Optimization of sub-channel bandwidth for mobile OFDM systems

Paper III

Theoretical analysis of pre-compensation for Rayleigh fading channels in QPSK TDD systems

Chapter 1

Introduction

The enormous increase in mobile telephone users makes the ether busy. New system solutions are soon required to take care of all new subscribers and their demands. The users do not just want their mobile phone for speech, but they also want the possibility to send and receive fax, e-mail and data – without delay. The requirements of capacity and speed in the network entail that today's systems have to be developed further or replaced by new ones. This thesis deals with one of the transmission techniques that can be used in these future mobile telephone systems, the Orthogonal Frequency Division Multiplex technique or OFDM.

The current mobile telephone system in Europe, the GSM-system, was developed in the late 80's and then it was hard to foresee the enormous use of data communication that we have today. Few people had heard of the internet and the possibility of sending e-mail and data files from a mobile terminal sounded like a fun but unnecessary feature of a phone. Besides, the expected number of subscribers was maybe a tenth of the actual situation today, when about one third of the Swedes have their own mobile phone. The GSM-system is mainly designed for speech and some drawbacks have shown up, mostly in terms of capacity and speed. To get rid of some of the problems the GSM-system will be further developed and probably some new systems will be developed in parallel.

It is important that the new systems have high capacity, can provide high speed and are flexible, i.e. that they can provide the data rates and services required by the users both for speech and for high end applications such as video. High capacity is achieved by transmitting low power, but then the signal is very sensitive to disturbances, which may be either noise or interference from other users. High speed can be achieved by letting the time for one symbol, the symbol time, become very short. But then problems with echoes due to reflections from buildings, mountains, cars etc. arise. Finally, high flexibility is achieved by designing the system in such a way that it can support different user requirements, but then it is important not to lose efficiency in the transmission.

Obviously there always are a lot of considerations that need to be taken into account in the design process. There are a lot of optimization problems that have to be solved. Between the extremes there is hopefully a golden mean and this is what I try

to find during my research, the golden mean for channel problems in conjunction with one of the candidates for future generations of mobile telephone systems, namely OFDM – Orthogonal Frequency Division Multiplex.

Chapter 2

Background

This chapter gives an introduction to OFDM, the radio channel and some of the problems involved in mobile OFDM systems design. It is meant to serve as a background to the included papers and not as a complete description. First some basics of digital communication are presented, then there is a description of the OFDM technique and a detailed description of the channel estimation problem. Finally, a technique called pre-compensation is presented, which is a method where the signal to be sent is compensated in advance for channel impairments in order to get better performance.

2.1 The radio channel

In digital communication systems the aim is to transmit digital bits from one point to another. A channel is used in some way in order to transmit the information. The channel may be the space, the sea or some sort of cable. Since this thesis is directed towards mobile communications, the channel used in the following is generally the air in which the radio wave propagates with reflections from surface objects. The bits to be transmitted are mapped from ones and zeroes to waveforms suitable for the radio channel, e.g. a high frequency cosine with phase shifts representing the sent bits. The radio channel has some special properties which affect the design of mobile communication systems, especially when it comes to the design of cellular systems. Of particular interest are the reflections of the sent signal, the attenuation of it, the changes of these parameters and the limited available bandwidth. Below follows a description.

2.1.1 Reflections

Reflections are one of the main properties that make the design of a cellular system challenging. They are caused by buildings, the ground, mountains, cars etc. which are "hit" by the radio wave, see figure 2.1.

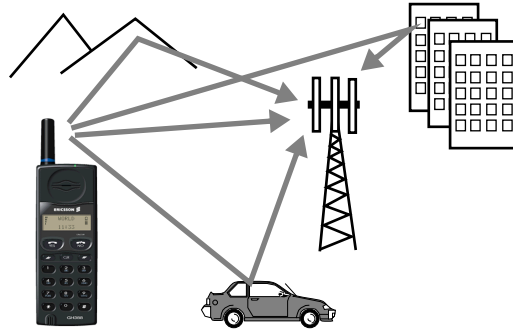

Figure 2.1: Reflections from a mobile terminal to a basestation.

The received signal can be described as a sum of all reflections, but since the radio wave has different propagation ways there is a certain delay for each of the rays. Mathematically the channel can be described by the impulse response [16]

$$h(\tau, t) = \sum_{q=1}^Q a_q(t) \cdot \delta(t - \tau_q(t)), \quad (2.1)$$

which is non-stationary due to movements of objects. In the above equation $\delta(t)$ denotes the Dirac delta-function and the index q represents the different echoes, where $q=1$ means the first echo arriving to the receiver. An important channel parameter is the maximum excess delay, which is a measure of the maximum difference in delay between the last and the first echo exceeding a specific level [23], i.e. $\tau_Q(t) - \tau_1(t)$.

Reflections with the same delay reach the receiver at the same time and the sum of these builds up a so-called tap. The tap coefficients, $a_q(t)$, describe the strength of the reflection components (for each delay τ_q) and how they vary with time. The result of the reflections is an amplitude change and a corresponding phase shift of the sent signal. Since the delays and tap coefficients vary all the time the channel is used to be characterized by some statistical model. One such model, used in the GSM specification, is specified by the COST 207 group as a "Typical Urban" channel [1]. In this model the relative power of the different taps is given, together with the corresponding delay, see figure 2.2.

The statistics of the variations are also specified in the model. Often, the terminal and some of the reflection points move and these movements result in a Doppler shift. When the mobile terminal moves towards the receiver the received frequency of the direct path is increased, but a reflex right behind the terminal will give a decreased frequency. This means that the receiver at any one time will receive a band of frequencies when reflections are present, even though only one frequency is transmitted. This effect is called Doppler spread [22]. Clarke derived a channel model [8] where it is assumed that the receiver receives reflections from all possible directions. The resulting received spectrum has the form of a bowl centered around the carrier frequency [8] [16], see figure 2.3, with edges at $\pm f_D$, the maximal Doppler frequency.

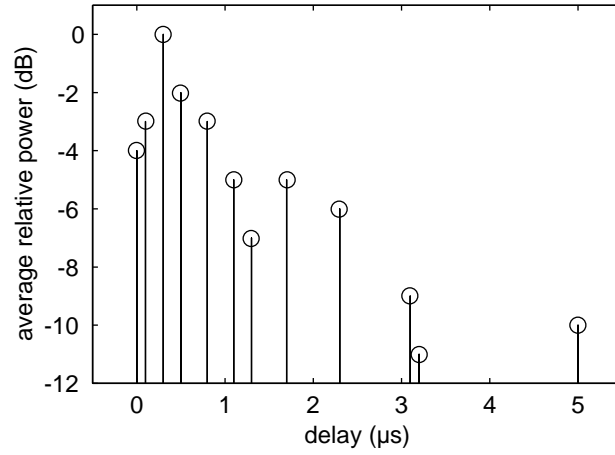

Figure 2.2: Relative powers and delays in the COST 207 "Typical Urban" model.

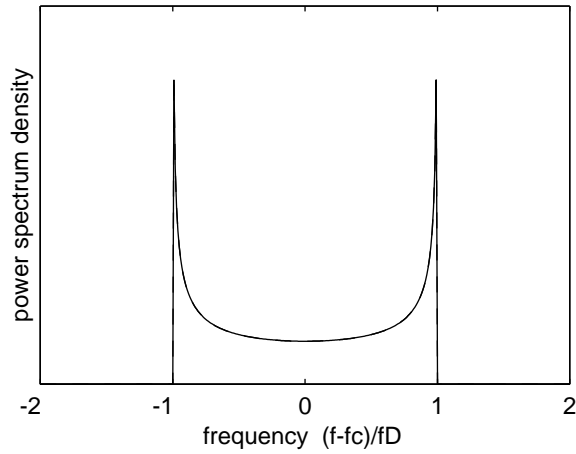

Figure 2.3: Received spectrum for Clarke's channel model.

2.1.2 Transfer function

Sometimes it is desirable to analyze the influence of the channel in the frequency domain instead of the time domain and then the transfer function is a valuable tool. The transfer function, $H(f, t)$, is simply the Fourier transform of the impulse response and can be calculated as

$$H(f, t) = F\{h(\tau, t)\} = \sum_{q=1}^Q a_q(t) \cdot e^{-j2\pi f \tau_q(t)}. \quad (2.2)$$

It describes the attenuation and phase shift of e.g. the channel for each of the frequency components in the transmitted signal.

2.1.3 Coherence time and coherence bandwidth

The autocorrelation function, $\rho_T(\Delta t)$, of a variable is an important measure of how a certain variable is dependent on itself from one time instant to another. For stationary processes it can be calculated as the expectation of the value of a variable multiplied by the value of the same variable at a time Δt later, i.e.

$$\rho_T(\Delta t) = E[x(t)x(t + \Delta t)]. \quad (2.3)$$

For Clarke's channel model the autocorrelation function of the received envelope is a zeroth order Bessel function of the first kind, which is dependent on the Doppler frequency and the time delay [16],

$$\rho_T(\Delta t) = J_0(2\pi f_D \Delta t). \quad (2.4)$$

The autocorrelation function is important because it describes how samples of the channel are coupled to each other and this information is often used in channel estimation filters. There is also an autocorrelation function in frequency which describes the coupling between the transfer function values for a certain frequency separation. The frequency correlation is dependent on the carrier frequency used, the power delay profile of the channel and mean power of the different taps. In order to describe the time and frequency range over where the correlation is high one can use the coherence time and coherence bandwidth. The coherence time is defined as the time span where the correlation exceeds a specific limit, e.g. $\rho_T(\Delta t) = 0.5$, whereas the coherence bandwidth is defined as the bandwidth where the correlation between the channel transfer functions $\rho_F(\Delta f)$ exceeds the same value. The coherence time, T_c , and the coherence bandwidth, B_c , can be estimated as [22]

$$T_c \approx \frac{1}{f_D} \text{ and } B_c \approx \frac{1}{\tau_0(t) - \tau_1(t)}. \quad (2.5)$$

The coherence time is inversely proportional to the Doppler frequency and can be interpreted as "the time over which the channel is constant". The coherence bandwidth is inversely proportional to the excess delay and can in the same manner be seen as a measure of "the bandwidth over where the channel is flat". That means that the coherence time is short when a mobile terminal moves fast and the coherence bandwidth is small when long delayed reflections are present, e.g. in hilly terrains. An example of the correlation function for the "Typical Urban" channel [1] is shown in figure 2.4.

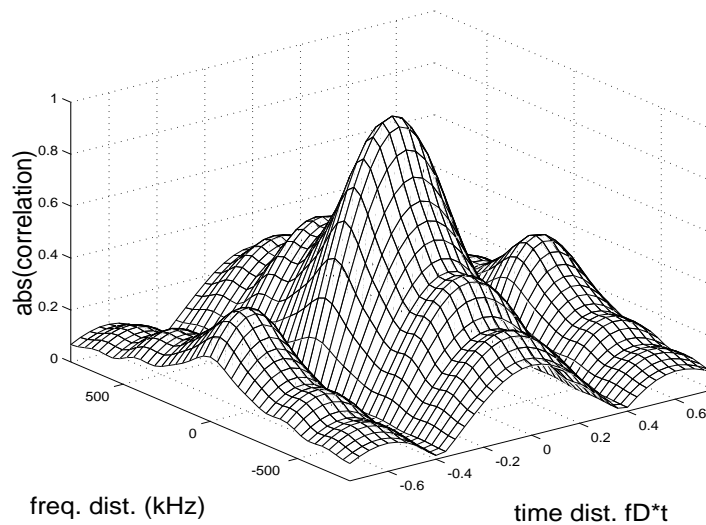

Figure 2.4: Time- and frequency correlation for a "Typical Urban" channel.

2.2 Single- or multicarrier systems?

Reflections cause problems in communication systems since the signals from different echoes arrive at different time instants to the receiver. This means that the received signal is a sum of the signal sent at different time instants and so-called inter symbol interference, ISI, arises [22]. When the symbol time is short compared to the excess delay then the ISI spans over several symbols and this effect has to be suppressed by the receiver. Normally this can be accomplished by an equalizer, e.g. a Viterbi equalizer [22], but when the ISI spans over many symbols the equalization procedure gets quite complicated. Today there is a growing interest for high speed mobile communication, and when the symbol rate is high, the symbol time is short and there is a risk that the ISI becomes severe. One way to get around this problem is to divide the data stream into several sub-streams and transmit each of them on its own frequency. Then the symbol time on each carrier frequency gets long even though the overall bitrate is high, and the problem with ISI originating from several symbols can be solved. However new problems arise as the duration of each symbol becomes long compared to the coherence time. The channel variations get fast compared to the symbol duration, which cause problems for the receiver and degrade the performance. Problems also arise when a transmitter has to transmit several signals at the same time. One of the reasons that single carrier systems are more popular than multicarrier systems is that the envelope of the sent signal may be constant. This is not the case in multicarrier modulation and therefore it is hard to design a power amplifier with high efficiency.

In order to get a spectrum efficient multicarrier system the sub-carriers have to be placed with minimum frequency distance between them but with enough distance such that they do not interfere with each other. This problem was solved in the late 60's [7] with overlapping spectra between the carriers, but with maintained orthogonality between them and the first "modern" OFDM system was invented.

2.2.1 Examples of practical systems

In the following sections we will use some existing systems, GSM, DECT, DAB and DVB, in order to discuss and relate parameters to what is used in reality.

GSM [11] is the pan European system for mobile telephony specified in 1990. It is mainly designed for speech, but offers some data services as well. GSM is a TDMA FDMA based system, often referred to as a second generation system, with eight users per channel and a channel data rate of 271 kbit/s. The system was originally designed for the 900 MHz band, but is now also used in the 1800 MHz band.

DECT [11] is the European digital cordless telephone standard. It is designed to offer a broad range of services for short range high density telecommunications. The system relies on a TDMA FDMA TDD structure and is not as "centralized" as GSM. The base stations are designed to work more independently of each other. The standard was finalized in 1992 and the system works in the 2 GHz band.

DAB refers to the digital audio broadcasting system in Europe [3], see appendix A for details. It was standardized in 1995 and is a multicarrier broadcast system for "near CD" quality in mobile, portable and fixed receivers. Besides the audio services the standard also supports transmission of multimedia signals. All the services are multiplexed into one data stream before transmission and a single frequency network is possible for transmission. This means that the same frequency can be used for simultaneous transmission of the same signal from many transmitter sites.

DVB is the new European standard for digital video broadcasting [2]. It is also a multicarrier system, but designed for higher data rates than the DAB system since it is intended for video transmission. The system supports single frequency networks as well and is meant for transmission on the same frequencies as the analog TV system.

2.3 OFDM

This section presents the basics of OFDM needed to understand the problems lying behind the included papers. It is not meant to give a complete overview of the technique, more exhaustive presentations of the OFDM concept can be found in e.g. [12], [4] and [9].

As mentioned before, the information can in OFDM systems be seen as transmitted on several sub-carriers. In principle an OFDM transmitter works in the following way [5]. The symbols to be transmitted are fed to a serial to parallel converter and then an inverse fast Fourier transform, IFFT, is performed. The samples from the IFFT are then converted to serial form, extended by a cyclic prefix (explained later), mixed to an appropriate frequency and transmitted over the radio channel, see figure 2.5. It is the IFFT that transforms the signals such that the samples from the parallel to serial converter constitute a signal where the data can be seen as transmitted on several sub-carriers. All of the values from one IFFT constitute samples from one OFDM symbol. Therefore the symbol time for the OFDM symbol is M times longer than the symbol time for the data symbols [4], where M is the number of points in

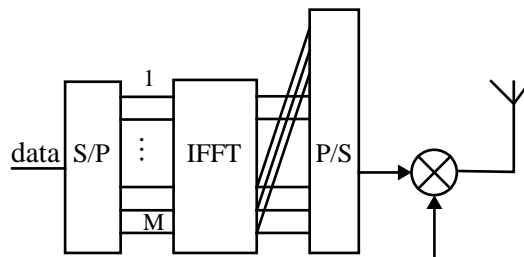

Figure 2.5: Block description of an OFDM transmitter

the IFFT. In this way it is possible to extend the OFDM symbol time, and get it much longer than the maximum excess delay, thereby making the echoes affect only the first part of the next symbol, but not more.

2.3.1 Cyclic prefix

Even though the symbol time is much longer than the maximum excess delay, there is still some intersymbol interference, ISI. The so-called cyclic prefix, which was introduced in the early 80's in [18], may be used to get around this problem. The receiver can handle echoes within one OFDM symbol since these only result in a phase and amplitude change, but it can not handle echoes between the symbols. In the following it is described how the idea of the cyclic prefix can be used to handle multipath delay such that the demodulated signal is free of both intersymbol interference and interchannel interference, ICI.

The solution to the problem is to make the echoes affect only one symbol at a time by extending the symbol time. The last samples from the IFFT are then copied and transmitted before the first IFFT samples. At the receiver side the receiver discards the (just added) first samples of the received symbol, and the original first samples are now affected only by echoes from its own OFDM symbol, and not from previous symbols, see figure 2.6. Mathematically speaking: The linear convolution performed by the channel is transferred into a cyclic convolution [9], which after the FFT acts like a scalar multiplication by the channel transfer function.

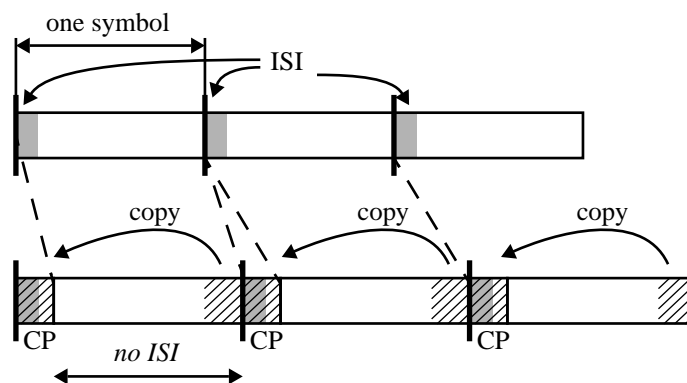

Figure 2.6: Insertion of the cyclic prefix, CP, means that the ISI can be removed by the receiver without loss of orthogonality between the symbols.

No ISI arises as long as the length of the cyclic prefix exceeds the maximum excess delay, i.e. the difference in delay between the last and first echo. However, the use of the cyclic prefix has some drawbacks. Naturally, the total symbol time including the cyclic prefix has to be longer than the maximum excess delay, which in turn limits the signalling rate on each sub-channel. There is also a waste of power since the transmitter discards the energy spent on the cyclic prefix. In the early OFDM systems [31] a guard space, a period of silence, was used between the symbols instead of the cyclic prefix. Then ISI is avoided but the sub-channels are not entirely orthogonal and some ICI arises. Anyhow the guard space or transmission of the cyclic prefix takes some extra time and the bitrate is degraded. The last problem can be solved by faster signalling, but then more bandwidth is occupied instead. So, one has to choose the "golden mean" between having enough cyclic prefix in order to avoid or suppress ISI, but short enough not to waste too much energy or bandwidth.

2.3.2 Sub-channel bandwidth

In OFDM systems the total bandwidth can be seen as divided into sub-channels and therefore we can associate a specific sub-channel bandwidth, or sub-channel spacing, with them. In the following we use the term sub-channel bandwidth to denote the distance in frequency between the different sub-channels even though the actual bandwidth of each sub-channel is much larger. Figure 2.7 shows a symbolic plot of four sub-carriers in an OFDM system.

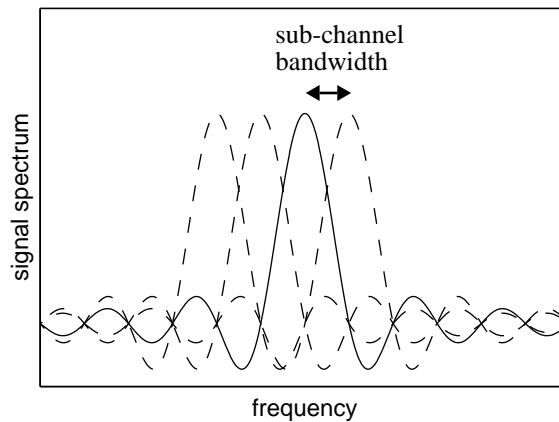

Figure 2.7: Symbolic representation of four sub-channels in an OFDM system.

The bandwidth is dependent on the data rate on each of the sub-channels. Many sub-channels means that the data rate on them is low and then the corresponding bandwidth becomes low, and vice versa. The advantage of having many sub-channels is that the duration of the cyclic prefix becomes short compared to the symbol time, which reduces the waste of bandwidth and energy. But, the orthogonality between the channels relies on the assumption that the channel characteristics remains constant during a symbol interval. The sub-channels start to disturb each other when changes of the echo-pattern during a symbol interval becomes perceptible [26] and interchannel interference arises. The symbol time gets long when many sub-carriers are used and the channel changes caused by e.g. movements of the mobile terminal,

become evident. Therefore the choice of sub-channel bandwidth is not obvious. On the one hand we want to have several sub-channels and long symbols in order to keep the duration of the cyclic prefix small. On the other hand we want to have few sub-channels and short symbols in order to avoid channel changes during a symbol and maintain orthogonality between the sub-channels. The second paper included in this thesis [29] treats this problem and how to find the trade-off between the extremes.

2.3.3 Transmission models

An OFDM system is free of both ISI and ICI if the coherence bandwidth is much greater than the sub-channel bandwidth, the channel changes are negligible during a symbol interval and the length of the cyclic prefix is long enough to exceed the maximum excess delay [9]. Since the sub-channels are not influenced by each other it is possible to define a model for the OFDM system where the signal is transmitted on separate Gaussian channels [9]. The sent data symbols are phase shifted and attenuated by the transfer function, $H_{k,m}$, of the sub-channel, m , at time, k . Finally the symbols are disturbed by white Gaussian noise, $n_{k,m}$, see figure 2.8.

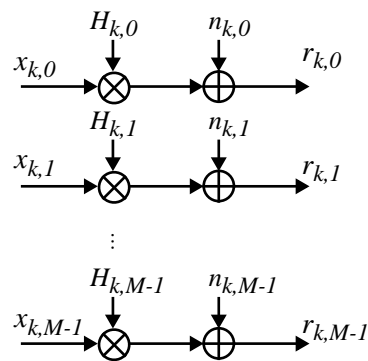

Figure 2.8: OFDM system model when ISI and ICI are avoided.

Note that no complex equalizer is needed in the receiver, just a phase shift and maybe an amplitude compensation for each carrier. This is the one of the main reasons why OFDM is attractive for mobile communication.

The transfer functions are correlated with each other as described in section 2.1.3. If the transfer function of a specific channel at a certain time is bad, i.e. has a low amplitude, then the adjacent transfer functions are quite likely to be bad too, and vice versa. Decreasing the sub-channel bandwidth increases the frequency correlation and decreases the time correlation of the different transfer functions.

2.3.4 Differential vs. coherent detection

Either differential or coherent detection can be used when demodulating the received signal [22]. Differential detection of PSK-signals means that the receiver makes its decisions based on the phase difference between two successive symbols

instead of the absolute phase. The phase difference can be achieved by multiplying the received symbol value by the complex conjugate of the previous or adjacent one, see figure 2.9.

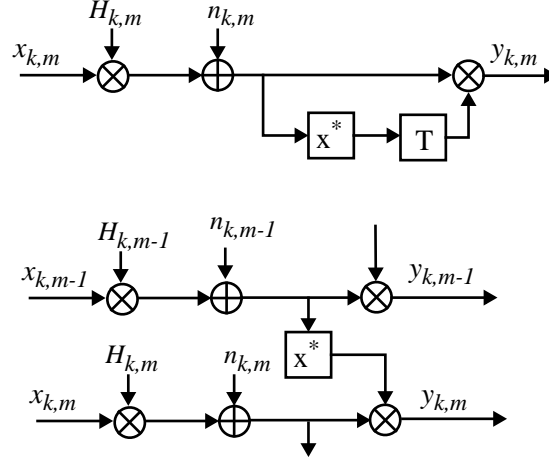

Figure 2.9: Calculation of decision variables for differential detection. Differential detection in time (top) and in frequency (bottom).

The resulting decision variable is in case of differential detection the phase of [22] either

$$y_{k,m} = (x_{k,m}H_{k,m} + n_{k,m})(x_{k-1,m}H_{k-1,m} + n_{k-1,m})^* \quad (2.6)$$

or

$$y_{k,m} = (x_{k,m}H_{k,m} + n_{k,m})(x_{k,m-1}H_{k,m-1} + n_{k,m-1})^* \quad (2.7)$$

depending on whether differential signalling in time or in frequency is used. Normally the one is chosen where the channel correlation is the largest since the changes should be caused by data and not by the channel. In the ideal case the transfer function is constant but since we use the difference between two disturbed values we get two noise contributions. If the transfer functions differ for the two symbols, we get an additional deviation from the ideal value.

Coherent detection is based on one received value at a time and relies on the knowledge of a reference phase and amplitude for the symbols. The received symbol values are compared with the reference and then decisions are made. The reference phase and reference amplitude are obtained by estimating the influence of the channel on the sent symbols, and the goal is to undo this influence. The decision variable for coherent detection is

$$y_{k,m} = (x_{k,m}H_{k,m} + n_{k,m})/\hat{H}_{k,m} \quad (2.8)$$

where $\hat{H}_{k,m}$ is an estimate of the transfer function at time k of channel m . For PSK systems only the phase is interesting so that equation (2.8) may be changed to

$$y_{k,m} = (x_{k,m}H_{k,m} + n_{k,m})\hat{H}_{k,m}^* \quad (2.9)$$

which is shown in figure 2.10.

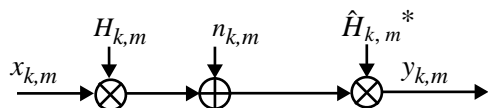

Figure 2.10: Decision variable for coherent PSK detection.

If the channel is known then $\hat{H}_{k,m} = H_{k,m}$ and compared to equation (2.6) we have only one noise contribution in this case. This means that if it is possible to know the channel impact in some way, then we can accept around two times (3 dB) more noise for the same performance. One may argue that if perfect coherent detection could be performed, then around 50% of the power could be spent on pilot symbols for channel estimation and synchronization. The question is how to get this channel information without too much loss. If the channel estimate is bad, we may get a performance which is worse, where the 3 dB gain may be turned into a loss instead. However, it turns out that only a few percent of pilot symbols is sufficient to enable reliable channel estimates [20] which can be used for coherent detection.

The choice between coherent or differential detection is also a question of receiver complexity. In some cases it is desirable to have cheap receivers and then it is better to use differential detection to get rid of the channel estimation problem. In [24] it is argued that the losses due to channel estimation is in the same region as the 3 dB loss for differential detection and that there is no reason for using coherent detection in a mobile communication system. This depends on how channel estimation is performed and if the channel estimation is optimized for the actual propagation conditions it is shown in [6] that a coherent system has better performance.

2.4 Channel estimation

As seen in the last section, the receiver has to know the transfer functions of the different sub-channels and time instants in order to enable coherent demodulation. These transfer functions can be estimated by transmitting known signals, so-called pilot symbols or pilot tones, and comparing these with the received signals. Since both the sent phases and amplitudes are known, it is easy to estimate the channel influence on the channels where the pilot symbols are sent. Then the influence on the channels situated in between, i.e. the data channels, can be achieved by interpolation. The pilot symbols transmit no data and therefore it is desirable to use as few of them as possible. They occupy bandwidth which rather could be used for data transmission and, if the total energy is to be kept constant, they lead to a power loss for the data symbols. However, the number of pilot symbols can not be decreased arbitrarily since a certain amount is needed to enable reliable channel estimates.

It is also possible to use the data symbols as virtual pilot symbols [10]. The received signal is demodulated and if a decision is correct the corresponding symbol can be used as a known pilot symbol. The technique is called decision directed channel estimation and means that there is no need for extra known symbols to be sent. This of course increases the overall capacity compared to a pilot symbol based system if the decisions are correct. But the receiver does not know whether a decision is correct or not and the result is longer error bursts after rapid fades and slower acquisition.

2.4.1 Pilot symbol assisted modulation

Pilot symbol assisted modulation, PSAM, is a channel estimation technique where pilot symbols are inserted periodically into the data stream [6]. No special tones are reserved for pilot information and the characteristics of the sent signal remain the same, independent of whether data symbols or pilot symbols are sent. Cavers made an exhaustive analysis in [6] for the single-carrier case, and the extension to multicarrier systems is straightforward. In multicarrier systems we have the opportunity to interpolate the received channel information both in the time direction and in the frequency direction. This means that it is possible to use less pilot symbols for channel estimation, but nevertheless get reliable estimates. One can think of a time frequency grid where the impact of the radio channel has to be estimated. In the single carrier case this grid is very narrow and the pilot symbols can be put in a row along the time direction only. But, in the multicarrier case the time frequency grid is broader and the freedom to place pilot symbols is much greater, see figure 2.11.

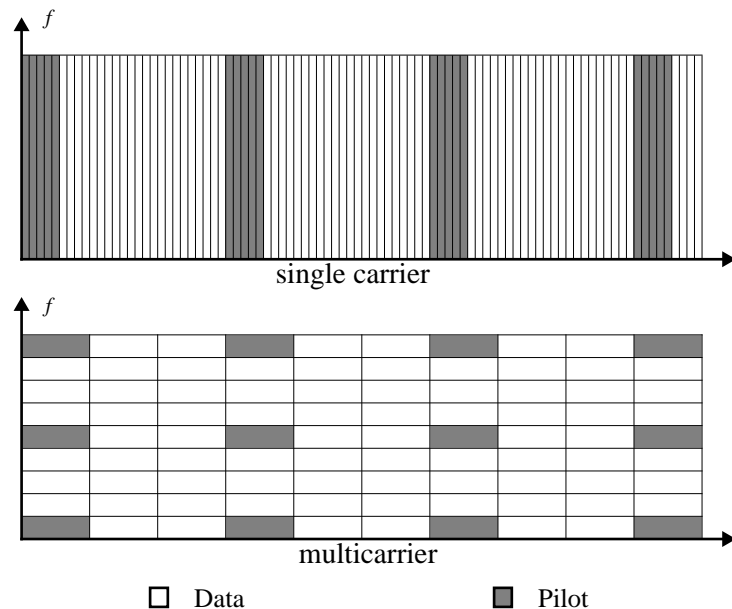

Figure 2.11: In multicarrier systems the pilot symbols can be spread in both the time and the frequency direction which decrease the number of required pilot symbols.

Paper one [28] addresses the problem of where and when to insert pilot symbols in the time-frequency grid. Different pilot patterns are analyzed and we examine the difference between single carrier and multicarrier systems. It is shown that it is possible to reduce the number of required pilot symbols a lot, up to ten times, by using a multicarrier system where the pilot symbols are placed in a pattern where both the correlation in time and in frequency can be utilized by the channel estimator.

The channel information derived from the pilot symbols has to be interpolated in some form in order to get the channel estimate for the data symbols as well. The optimal filter, in the sense that the mean square error is minimized, is the 2-dimensional Wiener filter [15]. The Wiener filter relies on a knowledge of the actual correlation between the data symbol of interest and all of the pilot symbols and between all the pilot symbols themselves. The channel estimate for a point is a weighted sum of all received pilot values, where pilot information in the vicinity (in terms of highest correlation) of the point have high weights. Since all pilot symbols contribute to all channel estimates in a block, large matrix operations are needed and therefore the filter becomes computationally heavy. In practical systems, some kind of simplifications have to be made, see e.g. [9] and [27] for detailed descriptions. One straightforward method is to use two 1-dimensional Wiener filters and interpolate in one direction at a time, e.g. first in the time direction and then in the frequency direction. The performance is similar to that of 2-dimensional filtering [15] and the complexity is reduced since no huge matrix operations has to be made. Another possible alternative is to use only the pilot symbols in the neighborhood for the estimate [9]. These are the most important ones since they have the highest correlation and pilot symbols far away from the actual point do not anyhow significantly contribute to the estimate.

2.4.2 Channel estimation in GSM

The GSM system is designed as a single carrier system. Therefore channel estimation in GSM is a little bit different from that in OFDM systems. The channel estimation procedure relies on the reception of known bits, which are called a training sequence, but in GSM it is the time domain properties of the channel that are of main interest [24]. The training sequence is located in the middle of each GSM burst, see figure 2.12. Each burst consists of 168 symbols and 26 of these ($\approx 18\%$) constitute the training sequence which is used for estimation and synchronization. A GSM burst has a duration of $546 \mu\text{s}$ and a good approximation to make a simple receiver is to assume that the channel remains constant during this time. This is not a necessary assumption but works well since time correlation of the channel is rather high within one burst. The channel correlation is approximately 0.97 from the middle of the burst to the end when the terminal is moving at a speed of 250 km/h, the worst case speed in the GSM channel models [1].

The receiver performance for a given channel is not specified in the standard, but a maximum excess delay of $16 \mu\text{s}$ is specified for the equalizer test channel model [1]. The type of equalizer to be used is neither given, however a Viterbi equalizer is commonly used [34]. Since the symbol time in GSM is $3.7 \mu\text{s}$, the channel estimator and equalizer have to mitigate ISI which may span over 5 symbols. The 8 training

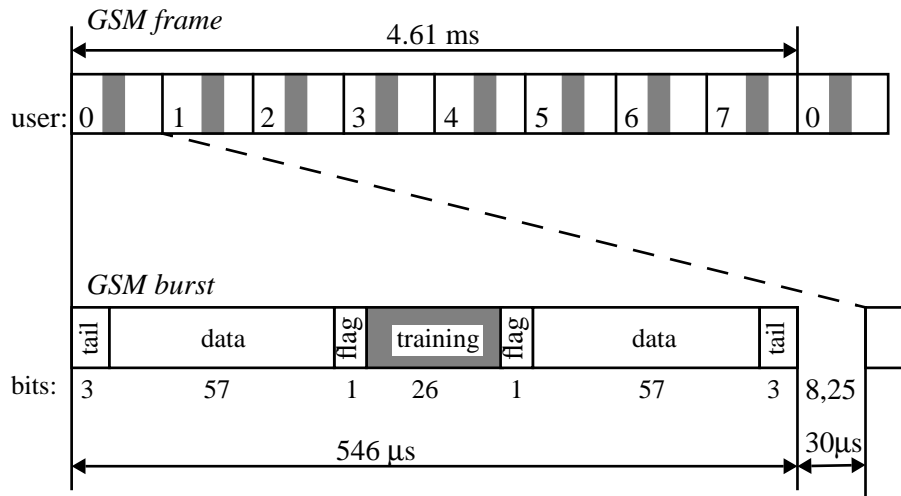

Figure 2.12: The structure of a GSM frame and a normal GSM burst [24].

sequences used for channel estimation consist of 26 symbols with good autocorrelation properties, i.e. an autocorrelation with a sharp peak for a certain delay but close to zero elsewhere.

The channel estimates are achieved by correlating the received training sequences with the known one, which is stored in the receiver. Since the autocorrelation function has a sharp peak, an estimate of the impulse response of the channel can be achieved from this correlation. This impulse response estimate is then fed to a Viterbi equalizer, which makes a decision in favor of the most probable sent sequence when the received one and the channel impulse response is known.

2.4.3 Channel estimation in DVB

OFDM and coherent demodulation is used in the Digital Video Broadcasting [2], DVB, system. It is mainly meant for stationary receivers, so the problems with Doppler broadening and an altering channel is not as big as in a mobile communication system, but it is anyhow interesting to study the channel estimation structure. The pilot symbols are used for several purposes, e.g. frame synchronization, frequency synchronization, time synchronization, channel estimation and phase noise tracking. In order to assist all these fields of applications the pilot symbols are located both at continuous pilot channels and as scattered pilots. There are in total 6817 sub-channels (in the 8k mode) and 177 of them are dedicated as pilot channels. The scattered pilots are located at every 12th sub-channel with a frequency shift of three sub-channels every new symbol, see figure 2.13.

The total pilot density is approximately 10%, which should be large enough to enable reliable channel estimates. For channel estimation only the pilot density may seem to be high, but the pilot symbols are used for other purposes too and robust detection is important when modulation schemes sensitive to estimation errors are used, e.g. 64-QAM.

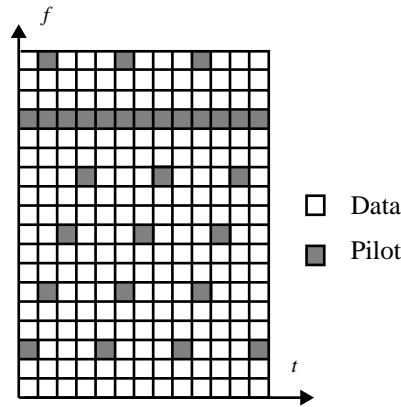

Figure 2.13: Example of pilot location in DVB.

2.4.4 How to design a pilot pattern

The most important parameters for the design of a pilot pattern are the expected maximum speed, which determines the minimum coherence time, and the maximum excess delay, which determines the minimum coherence bandwidth. The pilot symbols have to be placed close enough in order to be able to follow the time and frequency variations of the transfer function, but far enough not to increase the overhead too much. The lower limit for the pilot density is determined by the Nyquist sampling theorem if one wish to be able to follow all the variations, but in practice one has to sample the fading process more often, i.e. insert pilot symbols, in order to get reliable channel estimates. In [15] it is suggested as a "rule of thumb" to use twice as many pilot symbols in time respectively frequency as stated by the sampling theorem. A suitable choice of the pilot spacing in time, N_T , and in frequency, N_F , is therefore

$$N_T \approx \frac{1}{2} \cdot \frac{1}{2f_D T_{sub}} \quad (2.10)$$

and

$$N_F \approx \frac{1}{2} \cdot \frac{1}{2\Delta f \tau_{max}} \quad (2.11)$$

where Δf is the sub-carrier bandwidth, T_{sub} is the symbol time and τ_{max} the maximum excess delay of the channel. The influence of the pilot density is also investigated in [20] with similar conclusions. If a low complex channel estimator is used, e.g. two 1-dimensional estimators instead of one 2-dimensional estimator, the system is more sensitive to the choice of the pilot density, but the "twice the Nyquist frequency rule" seems to work well even in this case [20]. The relation between the pilot spacing in time and in frequency is important to minimize the pilot density. It is advantageous to have the same "uncertainty" in both the time direction and in the

frequency direction, to have a "balanced" [15] pilot pattern. This is accomplished by the design rules above and can be viewed as having the same distance between the pilot symbols in both directions, when normalized by the coherence bandwidth and the coherence time. If we define the coherence time as $1/f_D$ and the coherence bandwidth as the inverse of the excess delay, $1/(\tau_0(t) - \tau_1(t))$, then suitable pilot spacings are one fourth of the coherence time and coherence bandwidth respectively.

If the channel correlation functions are not fully known it is important to measure the "edge symbols", i.e. the outer channels in frequency and, if a block structure is used, the first and last symbols in each block. Then filtering and smoothing can be used and prediction can be avoided. In practical situations the channel characteristics is often not known since it is preferable to avoid requirements of e.g. measuring the Doppler frequency. For simplicity and robustness of the channel estimator it is often suggested to adjust it according to the worst case scenario [14] for the Doppler frequency and excess delay, i.e. to the minimum correlation in time and frequency. In order to avoid prediction pilot symbols are therefore suggested to be placed at the edge channels and then sufficiently many pilot symbols are uniformly placed between them in order not to exceed the pilot spacings given by the expressions (2.10) and (2.11).

The guidelines above are derived for a Rayleigh channel. If the channel sometimes is Ricean distributed and sometimes Rayleigh distributed the pilot pattern has to be designed for the worst case, i.e. the Rayleigh one, since the channel fluctuations are faster there. In the general case, one has to insert pilot symbols often enough to be able to follow the variations in time and frequency. What "often enough" means is determined by the Doppler spectra and the power delay profile for the whole system, i.e. including any hardware impairments such as oscillator drift and phase noise. The importance of the latter should not be underestimated when it comes to the design of new systems working at frequencies of several GHz.

The effect of different pilot densities is viewed in figure 2.14. For simplicity a single carrier system is assumed where every tenth symbol is a pilot symbol. If the symbol time is constant we may vary the doppler frequency in the system in order to study the effect of different pilot densities, or sampling rates compared to the Doppler frequency. Figure 2.14 shows the resulting mean bit error rate for 101 QPSK symbols when the Doppler frequency, which is assumed to be known by the receiver, is varied. The "Typical Urban" channel [1] is estimated by a Wiener filter and the resulting bit error rate is calculated using the method in the appendix of paper II.

For low signal to noise ratios the bit error rate is determined by the noise in the channel and the channel estimates are sufficiently good even for rather low pilot densities. But, as the signal to noise ratio increases, the bit error rate reaches an error floor, which is determined by the pilot density and the channel estimation errors. The crossing between the noise limited region and the channel estimate limited region is where the variance of the noise and the variance of the estimation error are equal. The estimate limited region can be avoided if the pilot density is high enough. For practical signal to noise ratios the expressions (2.10) and (2.11) seem to work well.

The bit error rate has similar behavior in case of OFDM with 2-dimensional filtering. The mean bit error rate for 30 sub-channels and 30 OFDM symbols is presented in figure 2.15. The levels of the estimate limited regions are somewhat lower com-

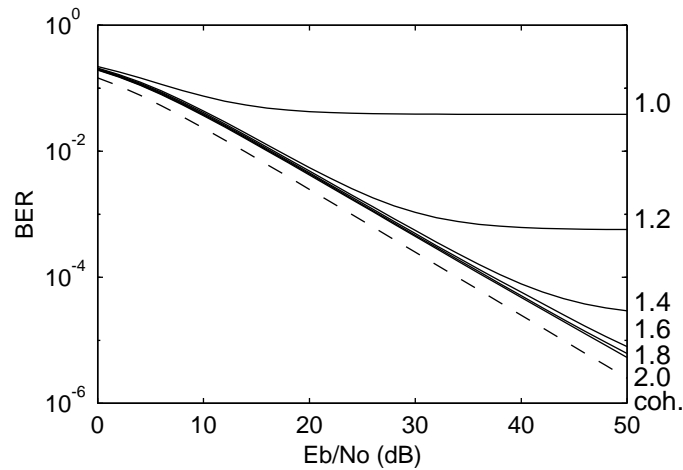

Figure 2.14: Mean bit error rate for different oversampling factors in a single carrier system. 1.0 corresponds to the Nyquist sampling rate.

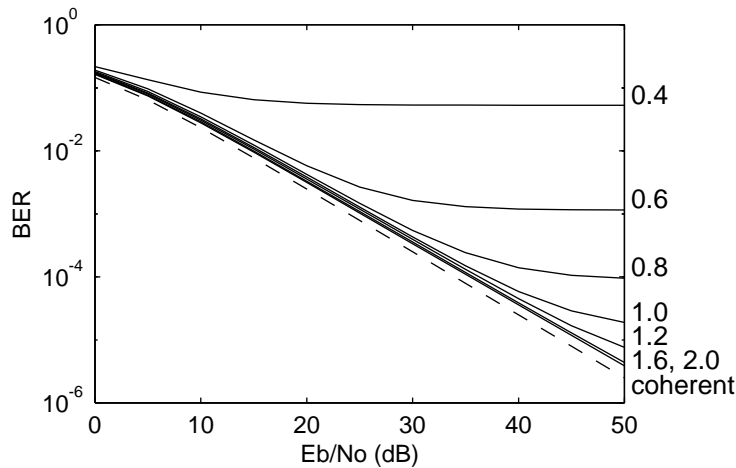

Figure 2.15: Mean bit error rate for different oversampling factors in a multicarrier system. 1.0 corresponds to the Nyquist sampling rate.

pared to the single carrier case due to the suppression of the peaks in two dimensions. This indicates the benefit of using some kind of 2-dimensional channel estimation, where filtering in the time direction as well as in the frequency direction is used.

2.5 Pre-compensation

Pre-compensation is a technique where the signal to be sent is compensated in advance for e.g. channel impairments in order to achieve better performance. The technique requires reliable estimates of the actual transfer function or impulse response. These estimates may for example be obtained by using pilot symbols in the same way as described in section 2.4. Pre-compensation is rather straightforward if a so-called TDD structure is used in the system, since the channel estimate for the incoming signal can be used for the outgoing signal as well.

2.5.1 TDD systems

Time division duplex, TDD, is a duplex technique where the same frequency is used both by the base station and the mobile terminal, but at different time instants. Think for example of a TDMA system with two time slots. If the user data rate is much smaller than the channel data rate, then one single channel may appear as a full continuous duplex connection to the user [23]. In TDD systems the possibility of making a prediction of the channel influence is rather straightforward. The used radio channel is often assumed to be reciprocal, see e.g. [18] [33], since the echo pattern and thereby the channel impulse response is the same both for uplink transmission, the transmission block from the mobile terminal to the base station, and downlink transmission, the block from the base station to the terminal. If the blocklength is short compared to the speed of change of the channel, then a channel estimate of the uplink block is quite likely to be valid for an adjacent downlink block too. This fact can be used to change the signal to be sent in a way such that better signal to noise ratio is achieved at the receiver or such that a more simple receiver can be used. Figure 2.16 shows the principle of the technique, often referred to as pre-coding or pre-compensation, used in an OFDM-TDD system.

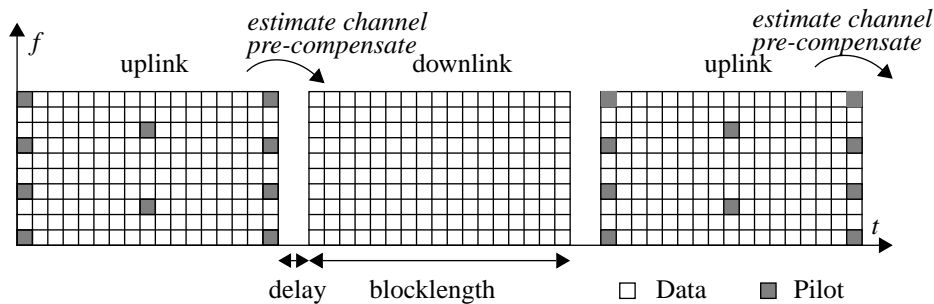

Figure 2.16: Block structure of a pre-compensated OFDM-TDD system.

The TDD structure can be used for different of pre-compensation methods, for example to control the output power [19] to achieve better performance or to modify the sent signal in order to suppress ISI [18]. The technique can also be used to implement a rather simple antenna diversity system at the base station which results in a diversity gain for both the base station and the mobile terminal [13]. Think for example of a system where two antennas are used at the base station. They are both receiving and measuring the incoming signal on the uplink. On the downlink the best antenna is used for transmission, thereby avoiding possible fading dips at the other antenna.

Between the uplink block and the downlink block there is often a delay [11], which is used to secure non overlapping transmission from the two transmitters. In a pre-compensated system the base station has to perform all the calculations and compensations within this delay so there is a need for fast processing in the base station.

2.5.2 Channel compensation

Channel estimation is a rather complex operation to perform, as seen in section 2.4. Every terminal has to make channel estimates in order to use coherent detection. By pre-compensation it is possible to move the task of channel estimation to the base station, but still achieve the performance benefits of coherent detection in the mobile terminal. Then cheap, less complex, mobile receivers can be used. The channel estimators at the base stations are used both for uplink and downlink equalization. Complexity and cost is not as important there since the equipment is shared among many users and connected to the main power system. The technique relies, as mentioned before, on a knowledge at the base station of the expected channel influence on the signal to be transmitted. The basestation estimates the channel influence, e.g. the transfer functions or the impulse response, on the downlink symbols and compensates the downlink symbols for this in advance, see figure 2.17.

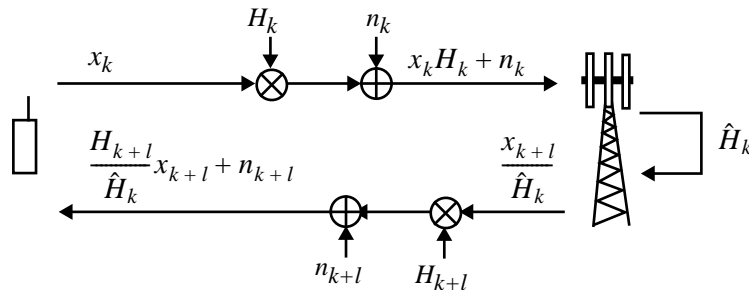

Figure 2.17: The principle of channel pre-compensation in an OFDM system.

If the compensation is correct, the influence of the channel is imperceptible to the receiver. Paper three [30] is an investigation of the theoretical performance of three different pre-compensation strategies when the channel is known. However, the channel transfer functions are likely to change as time passes. There is a maximum blocklength to be used, which is determined by the coherence time, before the performance has degraded too much.

The technique has shown to be promising for mitigating multipath distortion [18] of the radio signal. The latter is particularly interesting in e.g. CDMA systems where a complex so-called RAKE receiver often is necessary to mitigate the multipath spread. By pre-compensation the multipath problem can be taken care of at the base station where one can afford more advanced and complex receivers.

A pre-compensated system works like when two persons are playing outdoor ping-pong. In order to hit the table the players have to compensate for the wind and its force on the ball. They can observe the influence of the wind when the ball comes towards them and hopefully take the appropriate action before they have to hit the ball again.

2.5.3 TDD in DECT

DECT, Digital European Cordless System, is a standard for cordless telephony, mainly devoted to private systems within a home or office. It may however be used in metropolitan areas too or in conjunction with an area covering system such as GSM for "normal" mobile services [22]. The standard specifies a combination of FDMA, TDMA and TDD. A DECT frame consists of 24 time slots, 12 of them are used for uplink transmission and 12 for downlink, see figure 2.18.

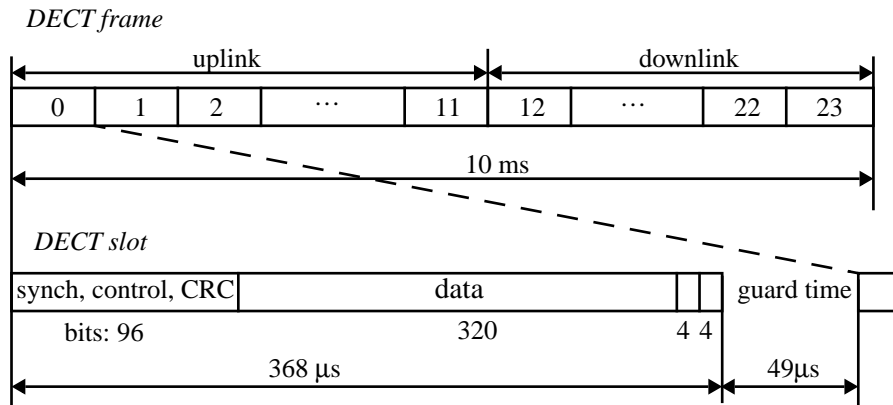

Figure 2.18: Frame structure in the DECT system [11].

In each time slot one out of ten carrier frequencies is used for transmission. The mobile telephone continuously measures the transmission quality of all the carriers and chooses the best one for communication [11]. The TDD structure is used for a simple pre-compensation arrangement, where antenna diversity is used as mentioned in the previous section. The base station has two receive antennas, which both receive the incoming signal simultaneously. Hence some kind of space diversity (antenna diversity) operation can be used on the uplink. One possible method for the space diversity system is to use e.g. selection diversity, which is easy to implement though it is not the optimal method [22]. The strongest signal is used for demodulation and the diversity arrangement only consists of the extra antenna, a sensing device and a switch. On the downlink pre-compensation is used in order to control the output power of the transmitter. Space diversity on the down link is achieved by using the same antenna as was used for reception. If the transfer function of the channel remains constant during the uplink and downlink block and if we assume equal disturbances at both ends, the best antenna on the uplink will also be the best on the downlink. Thereby is space diversity achieved both for the mobile terminal and for the base station, even though all the diversity equipment is located at the base station.

The performance of TDD systems are often sensitive to timing errors and especially pre-compensated systems are sensitive to fast changes of the used radio channel. The DECT system is therefore mainly used for pedestrian speed [22] and small propagation delays.

Appendix A

Some specifications of OFDM systems

Below follows a list of parameters used in some OFDM systems. DAB refers to the Digital Audio Broadcasting system in Europe [3]. DVB means the standard for the European Digital Video Broadcasting system [2]. BRAN, Broadband Radio Access Networks, refers to the preliminary work by an ETSI group for a wireless local area network [17] (one of the proposals). Finally, demonstrator refers to the test-bench built at the department of applied electronics as a co-project between some Swedish universities. The parameters for the demonstrator are very preliminary since the specification is not yet finalized.

Table A.1: *Parameters for some OFDM systems*

System	DAB (audio)	DVB (TV)	BRAN (wireless LAN)	Demonstrator (mobile radio)
Frequency band	(41MHz-223 MHz) ^a / (41MHz-1.5 GHz) ^b / >3GHz ^c	470 MHz-854 MHz	5 GHz	1.8 GHz or 5 GHz
FFT size	2048/512/256	8196 ^d /2048 ^e	512	1024
Useful sub-channels	1536/384/192	6817/1705	345	832
Sub-channel spacing (kHz)	1/4/8	1.11/4.46	39	≈20
Symbol time T_s , without CP (μ s)	1000/250/125	896	25.6	≈50

Table A.1: Parameters for some OFDM systems

System	DAB (audio)	DVB (TV)	BRAN (wireless LAN)	Demonstrator (mobile radio)
Length of cyclic prefix (compared to T_s , %)	24.6	25, 12.5, 6.25, 3.12	3.12	12.5
Modulation	$\pi/4$ D- QPSK	4-, 16-, 64- QAM	8-DPSK	16-QAM, 8- or 4-DPSK
Frame length (symbols)	76/76/153	68	128	4-8
Coding	Punctured conv. code, $R=1/4-8/9$	RS-code (204,188,8) + Punctured conv. code $R=1/2-7/8$	RS- code(86,70) +Block code $R=2/3^f$	Turbo-code, $R=1/2$
Useful bitrate (bits/s)	$32 \cdot 10^3$ - $384 \cdot 10^3$	$4.98 \cdot 10^6$ - $31.67 \cdot 10^6$	$15.93 \cdot 10^6$	$\approx 20 \cdot 10^6$

a. transmission mode I

b. transmission mode II

c. transmission mode III

d. 8k mode

e. 2k mode

f. constructed from a convolutional code

Chapter 3

Paper summary

The three papers in this thesis deal with radio channel problems in conjunction with OFDM. The papers are directed towards three different aspects:

- How to design a pilot pattern for channel estimation?
- Which sub-channel bandwidth to use?
- What can be gained if channel compensation is moved to the basestation?

The first paper is an investigation of different pilot pattern design strategies. Different pilot patterns are compared in terms of resulting bit error rate and a design method is given which minimizes the resulting bit error rate. It is shown that the pilot pattern used has a great influence on the system performance. By just a rearrangement of the pilot symbols, the bit error rate can be reduced by a factor five or the number of required pilots can be decreased by an order of magnitude.

The second paper addresses the problem of choosing a suitable sub-channel bandwidth for a mobile OFDM system. It is attractive in terms of capacity to have narrowband sub-channels, but then the symbol time gets long and there is a risk that the channel influence changes during the symbol duration. In that case the orthogonality between the sub-channels is lost and the sub-channels interfere with each other. In the paper this interchannel interference is modeled as additional (to the channel noise) additive white Gaussian noise and an optimization of the sub-channel bandwidth is performed regarding the interchannel interference and the energy loss caused by the cyclic prefix. It is concluded that the optimization can be performed without consideration to the influence of channel estimation. A closed form expression for the bit error rate in presence of the interchannel interference is given and it is argued that the bandwidth optimization has to be performed on a worst case assumption of the Doppler frequency and noise levels.

Finally, the third paper is a preparatory investigation of the possibilities of building a mobile pre-compensated communication system, where most of the channel problems are taken care of at the base station. A system is investigated where the base station performs channel estimation and compensates the signal to be sent for the expected impact of the channel. In such a system a simple receiver structure can be used, with a performance similar to that of a coherent receiver. Three compensation

methods are analyzed where amplitude and/or phase are adjusted in terms of resulting bit error rate and increase in peak-to-average ratio. It is concluded that phase-only compensation is preferred at low signal to noise ratios but for higher signal to noise ratios a bit error reduction by a factor 10 can be achieved by introducing amplitude compensation as well.

Chapter 4

Discussion

Some problems related to the radio channel are presented and discussed in this thesis. We have seen that the systems often have to be optimized for the actual parameters in order to get efficient systems. The number of required pilot symbols can be reduced a lot by optimizing the pilot pattern to the environment in which it will be used. The bit error rate may be decreased and the efficiency of the system may be enhanced if the sub-channel bandwidth is chosen according to the expected propagation conditions. Less complex receivers can be used if the signal to be sent is adjusted to the current channel impact. The above mentioned optimization problems are just a selection of optimizations that can be performed. They are not limited to adoption to the mobile radio channel, but the time varying radio channel may be interpreted as other time changing processes as well. This includes for example temperature variations in a wire, frequency drift in an oscillator etc.

Design of communication systems is often a question of adoption to specific requirements. In the future this will be an even more important task since it is hard to design systems or hardware that can cover all different needs. One has to identify the purpose of the system and design it accordingly. In order to satisfy all the requirements of bitrate, capacity and quality we will probably see surface covering systems, high capacity small area systems, semi-mobile systems for high bit rates, all designed for each specific task. A challenging problem is to get all these specialized systems to collaborate such that the subscribers will get an "ever working" communication system with high bit rates in the areas where needed, in so-called hot spots.

4.1 New mobile communication systems

Today it looks like an ever lasting race for new and better mobile communication systems. New services are introduced and soon we will probably have high capacity broadband systems, not mainly designed for speech. To my opinion the focus in the last year has been on the third generation systems, what to do after GSM. The standardization work within ETSI is running and the companies and universities within the EU-project FRAMES have recently decided which multiaccess technique they

propose for a future third generation system. They resolved to follow the wideband CDMA path which was marked out by the Japanese telecommunication company NTT by specifying and ordering such a (test) system. However, two of the proposals for the ETSI standard were based on OFDM, but the technique has until now found its niche in broadcast applications. There are discussions about using OFDM for wireless local area networks, where a simple channel equalization can be used even though the bit rate is in the order of 20Mbit/s.

There are some common goals for the new systems independent of the technology chosen. Often the new systems has to be flexible and support high data rates, the systems have to be both spectrally efficient and robust. The latter is maybe one of the most important qualities from a customers point of view. A non-working system is worth nothing even though the spectrum efficiency is splendid and it normally supports bit rates of 2 Mbits/s. It is important to search for robust solutions that can work in bad circumstances, e.g. at low signal to noise ratios. Therefore I think that the reception should rely on pilot symbols. To my opinion it is a good investment to use a few percent of the symbols as pilot symbols in order to get the 3 dB gain in signal to noise ratio.

4.2 Future work

From a capacity point of view it is interesting to allow higher interference levels in the radio channel. New coding schemes, e.g. turbo codes, have been invented that result in acceptable bit error rates for very low signal to noise ratios. However it is doubtful whether the synchronization circuits manage to fulfil their task in such a situation. It would be interesting to combine pilot symbol and data symbol based synchronization to see how much the performance could be enhanced. The same thing could be made for channel estimation in order to e.g. decrease the pilot ratio, but the question here is whether the gain is big enough to motivate the increased complexity.

When it comes to the determination of the sub-channel bandwidth one has to keep in mind that in paper II it is optimized without taking oscillator impairments into account. Frequency errors call for broader sub-channels and it would be nice to include this effect. However, there are already a lot of parameters to keep track of and this problem does not get easier with more parameters.

The evaluation of the pre-compensated systems is just a preparatory study. Much work remains in order to evaluate the technique. In reality the channel estimates are non-perfect and the resulting performance degradation has to be analyzed. The reliability of channel predictions and the corresponding pre-compensations get worse with increasing blocklength, and therefore suitable blocklengths have to be evaluated for mobile pre-compensated TDD systems. The latter problem relates in some way to the problem of determining the number of pilot symbols that have to be used in the channel estimator in order to follow time and frequency variations of the channel in a satisfactory manner.

Bibliography

- [1] European Telecommunications Standard Institute, GSM 05.05, version 4.6.0, July 1993.
- [2] "Digital broadcasting systems for television, sound and data services". European Telecommunications Standards Institute, prETS 300 744, Valbonne, France, 1996.
- [3] "Radio broadcasting systems; Digital Audio Broadcasting (DAB) to mobile, portable and fixed receivers", European Telecommunications Standards Institute, ETS 300 401, Valbonne, France, 1995.
- [4] M. Alard and R. Lasalle, "Principles of modulation and coding for digital broadcasting for mobile receivers", EBU Technical Review, no. 224, pp. 168-190, August 1987.
- [5] J. A. C. Bingham, "Multicarrier modulation for data transmission: An idea whose time has come", IEEE communications magazine, vol 28, no. 5, pp. 5-14, May 1990.
- [6] J. K. Cavers, "An analysis of pilot symbol assisted modulation for Rayleigh fading channels", IEEE Trans. Vehic. Tech. vol 40, no. 4, pp. 686-693, November 1991.
- [7] R. W. Chang, "Synthesis of band-limited orthogonal signals for multichannel data transmission", Bell system technical journal, nr 45, pp. 1775-1796, December 1966.
- [8] R. H. Clarke, "A statistical theory of mobile-radio reception", Bell Systems Technical Journal, vol. 47, pp. 957-1000, 1968.
- [9] O. Edfors, "Low-complexity algorithms in digital receivers", Ph.D. thesis, Luleå University of Technology, Luleå, Sweden, 1996.
- [10] P. Frenger, "Multicarrier modulation and coding for multichannel systems", licentiate thesis, Chalmers University of Technology, Göteborg, Sweden, February 1997.
- [11] J. D. Gibson, editor, The mobile communications handbook, CRC-press, Boca Raton, FL, USA, 1996.
- [12] D. Harvatin, "Orthogonal frequency division multiplexing (OFDM) performance in a mobile radio channel", Technical report EAS_ECE_1996_16, University of Colorado, Boulder, USA, December 1996.

- [13] P. S. Henry, B.S. Glance, "A new approach to high-capacity digital mobile radio", *The Bell system technical journal*, Vol. 60, no. 8, pp. 1891-1904, 1981.
- [14] P. Hoeher, "TCM on frequency-selective land-mobile fading channels", in E. Bilglieri and M. Luise, editors, *Coded modulation and bandwidth-efficient transmission*, pp. 317-328, Elsevier Science Publications, Amsterdam, The Netherlands, 1992.
- [15] P. Hoeher, S. Kaiser and P. Robertson, "Pilot-symbol-aided channel estimation in time and frequency", in K. Fazel and G. P. Fettweis, editors, *Multi-Carrier Spread-Spectrum*, chapter IV, pp. 169-178, Kluwer Academic Publishers, Dordrecht, The Netherlands, 1997.
- [16] W. Jakes, *Microwave Mobile Communications*, Wiley-Interscience, USA 1974
- [17] P. Madec, D. Lacroix, D. Castelain, J. Veillard and B. Le Floch, "A COFDM air interface for wireless ATM networks (HIPERLAN2)", WG3 temporary document 33, ETSI EP BRAN, European Telecommunications Standards Institute, Valbonne, France, 1997.
- [18] A. Masoomzadeh-Fard and S. Pasupathy, "Combined equalization and differential detection using precoding", *IEEE transactions on communications*, vol. 45, no. 3, pp. 274-278, March 1997.
- [19] H. Matsuki and H. Takanashi, "Theoretical analysis of BER improvement by adaptive transmitter power control for Rayleigh fading compensation", *Electronics Letters*, 29, (17), pp. 1520-1521, 1993.
- [20] R. Nilsson, O. Edfors, M. Sandell, and P. O. Börjesson, "An analysis of two-dimensional pilot-symbol assisted modulation for OFDM". *Proceedings of IEEE International Conference on Personal Wireless Communications (ICPWC'97)*, Mumbai (Bombay), India, pp. 71-74, December 17-19, 1997.
- [21] A. Peled and A. Ruiz, "Frequency domain data transmission using reduced computational complexity algorithms", *Proc. IEEE Int. Conference Acoustics, speech, signal processing*, Denver, USA, pp. 964-967, 1980
- [22] J. G. Proakis, *Digital communications*, third edition, McGraw-Hill, New York, USA, 1995.
- [23] T. Rappaport, *Wireless communications, principles and practice*, Prentice Hall, Upper Saddle River, NJ, USA, 1996.
- [24] S. M. Redl, M. K. Weber and M. O. Oliphant, *An introduction to GSM*, Artech House Publishers, Boston, USA, 1995.
- [25] H. Rohling and T. May, "Comparison of PSK and DPSK modulation in a coded OFDM system, *Proceedings of IEEE Vehicular Technology Conference*, Phoenix, Az, USA, pp. 870-874, May 4-7, 1997.
- [26] M. Russell and G. L. Stüber, "Terrestrial digital video broadcasting for mobile reception using OFDM", *Wireless Personal Communications*, vol 2, nr 1-2, Kluwer Academic Publishers, Dordrecht, The Netherlands, pp. 45-66, 1995

- [27] M. Sandell, "Design and analysis of estimators for multicarrier modulation and ultrasonic imaging", Ph.D. thesis, Luleå University of Technology, Luleå, Sweden, 1996.
- [28] Fredrik Tufvesson and Torleiv Maseng, "Pilot assisted channel estimation for OFDM in mobile cellular systems", Proceedings of IEEE Vehicular Technology Conference, Phoenix, USA, pp. 1639-1643, May 4-7, 1997.
- [29] Fredrik Tufvesson and Torleiv Maseng, "Optimization of sub-channel bandwidth for mobile OFDM systems", in D. Everitt and M. Rumsewicz, editors, Multiaccess, mobility and teletraffic – advances in wireless networks, pp. 103-114, Kluwer Academic Publishers, Dordrech, The Netherlands, 1998.
- [30] Fredrik Tufvesson, Michael Faulkner and Torleiv Maseng, "Theoretical analysis of pre-compensation for Rayleigh fading channels in QPSK TDD systems", Series of technical reports, no. 3, ISSN 1402-8840, Department of Applied Electronics, Lund University, Lund, Sweden, January 1998.
- [31] S. B. Weinstein and P. M. Ebert, "Data Transmission by Frequency-Division Multiplexing Using the Discrete Fourier Transform", IEEE Transactions on Communications, vol. COM-19, pp. 628-634, 1971.
- [32] S. K. Wilson, "Digital audio broadcasting in a fading and dispersive channel", Ph.D. thesis, Stanford University, USA, 1994.
- [33] W. Zhuang and V. Huang, "Phase pre-coding for frequency selective Rayleigh and Rician slowly fading channels", IEEE transactions on vehicular technology, vol. 46, no. 1, pp. 129-142, Februari 1997.
- [34] S.O. Öhrvik, Radio school, part DM1, Ericsson Radio Systems, Stockholm, Sweden, 1993.

Paper I

Pilot assisted channel estimation for OFDM in mobile cellular systems

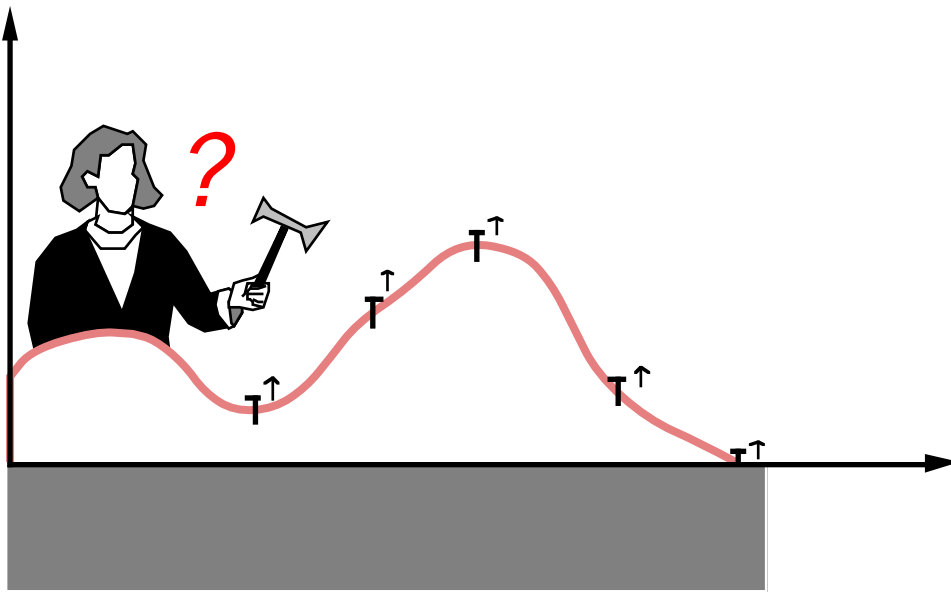

PILOT ASSISTED CHANNEL ESTIMATION FOR OFDM IN MOBILE CELLULAR SYSTEMS

Fredrik Tufvesson and Torleiv Maseng

Department of Applied Electronics, Lund University, Box 118, S-221 00 Lund, Sweden

E-mail: Fredrik.Tufvesson@tde.lth.se

Abstract — The use of pilot symbols for channel estimation introduces overhead and it is thus desirable to keep the number of pilot symbols to a minimum. The number of needed pilot symbols for a desired bit error rate and Doppler frequency is highly dependent on the pilot pattern used in orthogonal frequency division multiplexed, OFDM, systems. Five different pilot patterns are analysed by means of resulting bit error rate, which is derived from channel statistics. Rearrangement of the pilot pattern enables a reduction in the number of needed pilot symbols up to a factor 10, still retaining the same performance. The analysis is general and can be used for performance analysis and design of pilot patterns for any OFDM system.

I. INTRODUCTION

The mobile channel introduces multipath distortion of the signalling waveforms. Both the amplitude and phase are corrupted and the channel characteristics changes because of movements of the mobile. In order to perform coherent detection, reliable channel estimates are required. These can be obtained by occasionally transmitting known data or so called “pilot symbols”. The receiver interpolates the channel information derived from the pilots to obtain the channel estimate for the data signal, see Fig. 1.

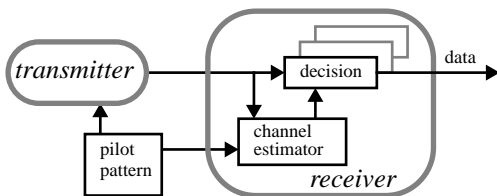

Fig. 1 The pilot pattern is known both by the receiver and the transmitter. The purpose is to minimize the number of transmitted pilot symbols without increasing the bit error rate.

OFDM, orthogonal frequency division multiplexing, is used and proposed for several broadcast systems and there is a growing interest in using the technique for the next generation land mobile communication system. In OFDM systems the information signal can be seen as divided and transmitted by several narrowband sub-carriers. Typically, for practical OFDM systems, the frequency spacing is less than the coherence bandwidth and the symbol time is less than the coherence time. This means that a receiver and pilot estimation pattern that take advantage of the relatively large coherence bandwidth and coherence time can manage with less pilot symbols, thereby minimizing the overhead introduced by the pilot symbols. The problem is to decide where and how often to insert pilot symbols. The spacing between the pilot symbols shall be

chosen small enough to enable reliable channel estimates but large enough not to increase the overhead too much. This paper includes among all an algorithm of how to design a suitable pilot estimation pattern.

In a multicarrier system there exist a unique opportunity to determine various parts of the channel impulse response, as opposed to a single-carrier system. It is no use to make efforts to determine already known parts. Until now it seems like no one has looked into the impact of the placement of the pilot symbols for multicarrier systems. Cavers [5] made an exhaustive theoretical analysis for single-carrier systems. He pointed out that it was appropriate that 14% of the sent symbols were pilot symbols to be able to handle large Doppler values ($f_d T_s = 0.05$). Some pilot estimation patterns for OFDM has been presented in the literature, see e.g. [6], [7]. Comparisons between these and the one proposed here are shown later.

II. ESTIMATION STRATEGIES

Five different pilot patterns are analyzed, see Fig. 2.

1. Measure all channels at the same time, compare to a broadband single-carrier system.
2. Measure the channels in increasing order, one at a time.
3. Measure the channels one at a time in a smart, but predetermined, way. The measurement order is derived upon channel statistics and is optimal in the sense that the total bit error rate is kept at a minimum each symbol time.
4. A pilot pattern presented by T. Mueller *et al.* [6], where the pilots are located with equidistant spacings in time and frequency.
5. A pilot pattern by P. Hoeher [7], used in [4]. The pilot symbol locations are shifted one step in frequency each pilot interval.

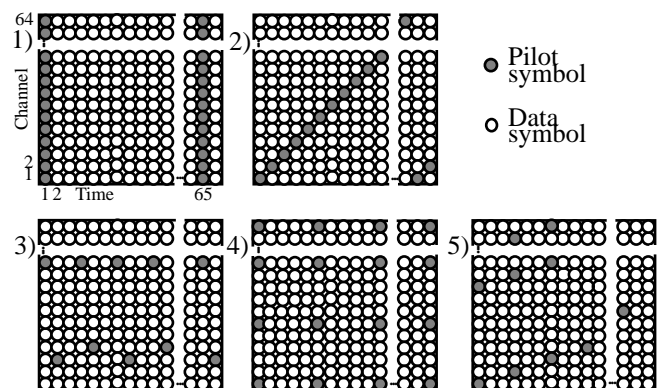

Fig. 2 Examples of pilot patterns analyzed.

For comparison the same amount of pilots is used, one of 64 sent symbols. This means that only 1.6% extra overhead is introduced by the pilots, but this is not sufficient for large Doppler frequencies in some of the cases.

III. SYSTEM

At different signal to noise ratios the resulting bit error rate from each pilot pattern is evaluated using the algorithms given in Section VIII. A matched filter receiver and coherent BPSK or QPSK are used. Additive white Gaussian noise is assumed for every sub-channel. The channel has delays and Rayleigh distributed amplitudes according to the COST 207: "Typical Urban profile". The complex parts of the transfer function are assumed to change according to a first order auto-regressive process as described in Section VI. The reason for using this model is to get a linear system which rather easy can be handled algebraically. A Kalman filter is used to estimate the frequency response of the channel. From the filter, a time dependent covariance matrix is given as described in Section VII. This is used to calculate the expected bit error rate for each channel. See Fig. 3 for a description of the system.

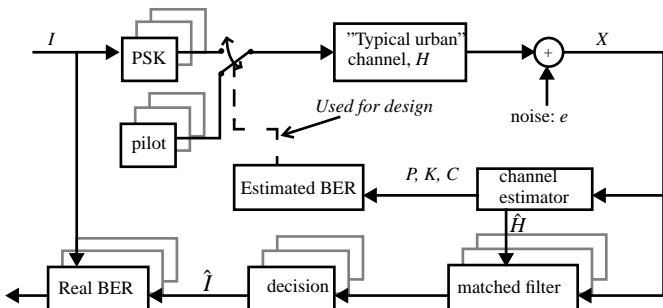

Fig. 3 Overview of the system used to analyze the estimation patterns.

IV. RESULTS

The resulting bit error rate curves of the pilot patterns are presented for different Doppler frequencies in Fig. 4.

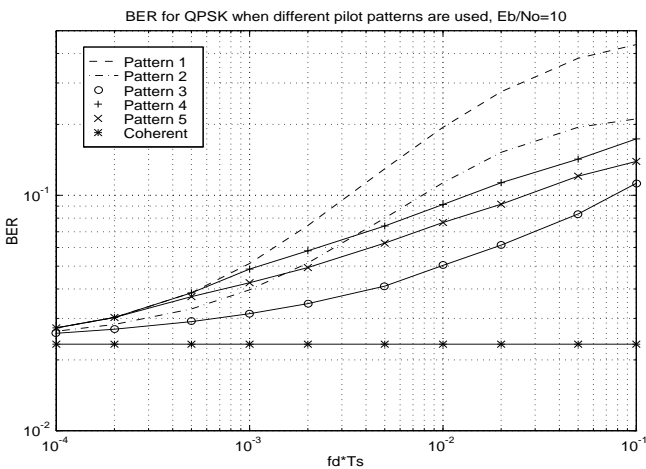

Fig. 4 Resulting bit error rate as a function of Doppler value when the different pilot patterns are used. The same number of pilot symbols are used for all curves.

For a given Doppler frequency the pilot pattern used sets the limit for the lowest pilot density to be used, alternatively for a given pilot density it limits the maximum Doppler frequency allowed. The calculations are made at 1800 MHz using 10 kHz channel separation between 64 OFDM channels carrying in total 640 ksymbols/s. No intersymbol interference, perfect synchronization and known Doppler frequency, f_d , is assumed. 1.6% of the sent symbols are pilot symbols and the average bit error rate of the 64 channels is presented.

The bit error rate is degraded both by imperfect channel estimates and noise disturbances. The pilot pattern used determines the conversion between noise limited and estimate limited region, see Fig. 5.

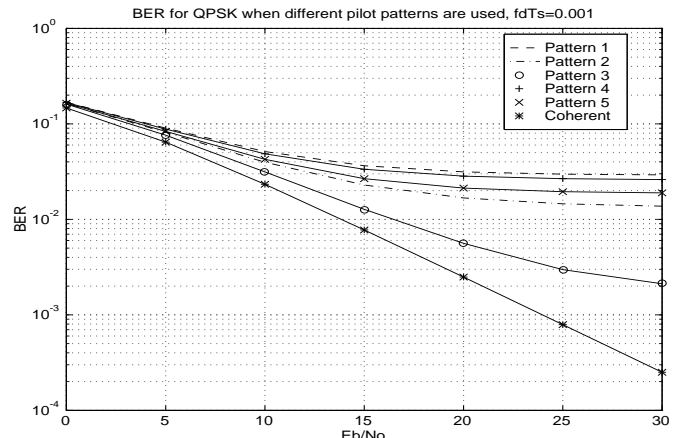

Fig. 5 Bit error rate at different signal to noise ratios. Note the difference between the error floors.

It is interesting to study the resulting pattern when estimating the channel that gives the lowest bit error rate (strategy 3). A steady state pilot pattern is often achieved where only few of the sub-channels are measured, see Fig. 6. Channel estimates of the other sub-channels are achieved by filtering.

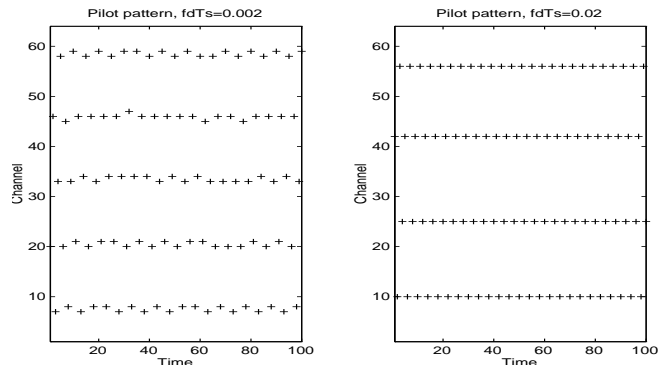

Fig. 6 Resulting pilot pattern when sending a pilot at the channel which gives the lowest total bit error rate. Note that only few channels will be used for pilot symbols.

To see the effect of mismatch between the pilot pattern design parameters and the actual parameters, the optimal pilot patterns (pattern 3) for three Doppler values were used when moving at another speed. The actual Doppler frequency was as before assumed to be known by the estimator, just to see the effect of the pilot pattern without influences of the estimation algorithm. The designed pilot patterns for the "typical urban" environment were also used in "hilly terrain" and "rural area"

specified in [2] to see the influence of the propagation environment on the bit error rate, see Fig. 7.

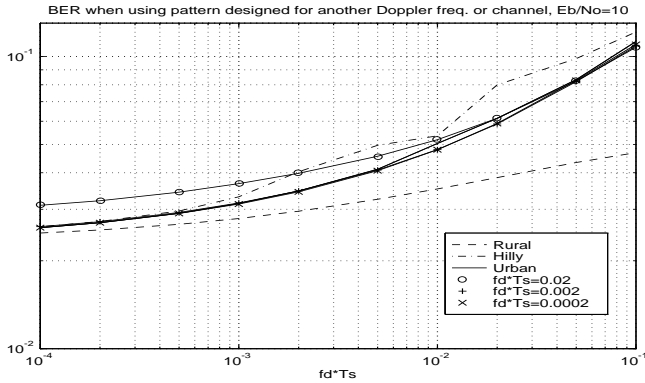

Fig. 7 Changes in the bit error rate due to Doppler mismatch and power delay profile mismatch. The pilot patterns designed for $f_d T_s = 0.02$, 0.002 and 0.0002 were used at different Doppler values and the designed patterns for typical urban environment were used in hilly terrain and rural area.

As seen in the figure, the pilot patterns are robust to mismatches in the design parameters.

V. DISCUSSION

To minimize the bit error rate it is desirable to spread the pilot symbols both in time and in frequency, as seen in Fig. 4 and Fig. 5. Normally a worst case design is made for the channel estimation system and then we suggest to tailor the pilot pattern to each base station site. A suitable pilot pattern can be calculated once the propagation environment and maximum expected speed in the particular cell is known. In such a system, the pilot pattern used in the cell is among the information transferred to the mobile when it logs into a new cell. When designing the pilot pattern one also has to take the estimation algorithm into account. Here the estimation algorithm is used only for evaluation and the complexity of the used algorithm is not a problem. In some cases the pilot pattern has to aid the estimation algorithm to enable a less complex one. The estimation algorithm used here, the Kalman filter based on an AR-process, has no delay and the received signal can be detected immediately, i.e. no future pilot symbols is taken into account when making the channel estimate. If the received signal is stored in a memory, the pilot symbols can be used in both "time directions" and the time spacings between pilot symbols can be increased, retaining the same performance.

The degradation due to mismatch in design parameters is mainly caused by the estimation algorithm and therefore the curves for different Doppler values do not differ much. When the pilot pattern is designed for higher Doppler values than the actual one, an increased error rate is achieved since the pilot symbols are not located as close to each other in frequency as desired. In rural area the bit error rate becomes lower due to the increased frequency correlation while the opposite happens in hilly terrain. In the first case, an even better result is achieved with less pilots along the frequency axes and more along the time axes.

The bit error rates within the sub-channels differ depending on where the pilots are located. When minimizing the total bit error rate (pattern 3) the channels of the sides get higher error rate, see example in Fig. 8.

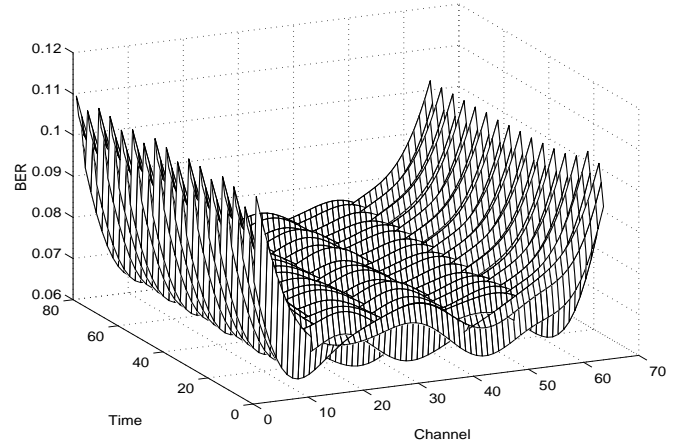

Fig. 8 The bit error rate becomes higher for the side channels when the total bit error rate is kept at a minimum

VI. CHANNEL MODEL

The time dependent impulse response, $h(\tau, t)$, is assumed to be a sum of reflections, see (1) where $\delta(t)$ denotes the dirac-function.

$$h(\tau, t) = \sum_{n=1}^N a_n(t) \cdot \delta(t - \tau_n) \quad (1)$$

The tap coefficients, $a_n(t)$, and the tap delays, τ_n , are chosen according to the COST 207 "Typical Urban" model in the GSM specification [2]. The transfer functions, $H(f, t)$, are obtained by the Fourier transform and these are the functions we want to estimate for the different carriers. These channel transfer functions are regarded as flat fading and constant during a symbol time.

A first order AR-process is used to model how the different taps may change from one time instant to another. If we look at all the transfer functions at the same time, it is possible to set up a state-space model of the form:

$$\begin{aligned} H(k+1) &= \phi H(k) + v(k) \\ y(k) &= C(k)H(k) + e(k) \end{aligned} \quad (2)$$

The matrix ϕ is a diagonal $N \times N$ -matrix (here treated as a scalar) with elements

$$e^{-k_{AR} 2\pi f_d T_s} \quad (3)$$

that define the AR-process. T_s is the symbol time including any cyclic prefix or guard space. The white noise $v(k)$ has covariance matrix $R_1 = F \cdot R_{GSM} \cdot F^*$, where R_{GSM} corresponds to the multipath intensity profile described in [2]. The vector $y(k)$ is the measured transfer functions. $C(k)$ is an observation vector with ones only at the positions (channels) measured at time KT_s and $e(k)$ is measurement noise with a diagonal covariance matrix R_2 .

The parameter k_{AR} in the auto-regressive process for the channel changes is chosen to adjust the "memory" so that it

corresponds to the "memory" of Jakes' model. Channels corresponding to the U-shaped spectrum given in [8] were simulated and then estimators based on an AR-model with different k_{AR} were used, see Fig. 9

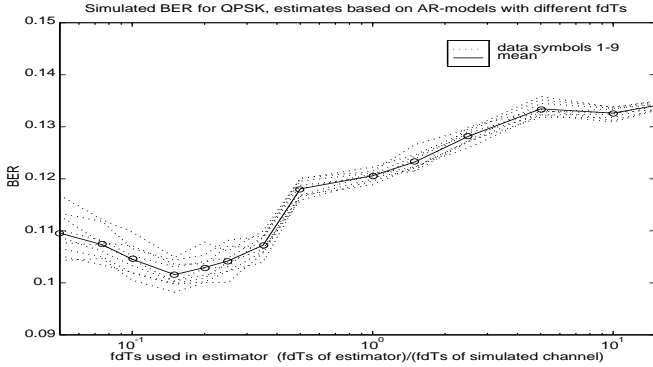

Fig. 9 Bit error rate for a simulated channel by Jakes when estimates are based on an AR-process. The minimum value is reached for $k_{AR}=0.15$.

Simulations were performed with one sub-channel ($E_b/N_o = 10$, $f_d T_s = 0.002$) with every tenth symbol as a pilot symbol. In the figure the bit error rates of the nine data symbols are shown. Fig. 9 shows that the best fit, in this case, is reached for $k_{AR} \approx 0.15$.

The adjustment of the AR-process can also be seen as an adjustment of the bandwidth. If we set the 90% power bandwidth of the AR process equal to the bandwidth of the Doppler spread, see Fig. 10, a value of $k_{AR} \approx 0.158$ can be calculated. This is the value used for all bit error rate calculations throughout the paper.

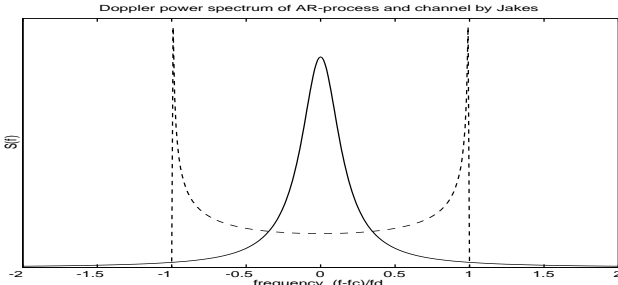

Fig. 10 Power density spectrum of the channel by Jakes and a first order AR-process. The latter is adjusted to have the 90% power bandwidth equal to the Doppler spread.

VII. CHANNEL ESTIMATOR

For the analysis and pilot pattern design a Kalman filter is used to estimate the transfer functions. The Kalman filter is causal and uses measurements up to time k to estimate the transfer functions, $H(k)$. The Kalman filter is given [3] by (4)-(8), where X^* denotes conjugate transpose of X :

$$\hat{H}(k|k) = \hat{H}(k|k-1) + P(k|k-1)C(k)^* \cdot \{C(k)P(k|k-1)C(k)^* + R_2\}^{-1} (y(k) - C(k)\hat{H}(k|k-1)) \quad (4)$$

$$\hat{H}(k+1|k) = \phi \hat{H}(k|k-1) + K(k)[y(k) - C(k)\hat{H}(k|k-1)] = \phi \hat{H}(k|k) \quad (5)$$

$$K(k) = \phi P(k|k-1)C(k)^* \cdot [C(k)P(k|k-1)C(k)^* + R_2]^{-1} \quad (6)$$

$$P(k+1|k) = \phi P(k|k-1)\phi^* + R_1 - K(k)[C(k)P(k|k-1)C(k)^* + R_2]K(k)^* \quad (7)$$

$$P(k|k) = P(k|k-1) - P(k|k-1)C(k)^* \cdot [C(k)P(k|k-1)C(k)^* + R_2]^{-1} C(k)P(k|k-1) \quad (8)$$

The reconstruction error $\tilde{H}(k|k) = H(k) - \hat{H}(k|k)$ is given by:

$$\tilde{H}(k|k) = [\phi - K(k)C(k)]\tilde{H}(k-1|k-1) + v(k-1) - P(k|k-1)C(k)^* [C(k)P(k|k-1)C(k)^* + R_2]^{-1} \cdot \{e(k) + C(k)v(k-1)\} \quad (9)$$

The Kalman filter is optimal in the sense that the variance of the reconstruction error is minimized. The matrix $P(k|k)$ is the variance matrix and this is used together with K to make an estimate of the bit error rate, which in turn is used to decide the order in which the channels are going to be measured. For pattern 3, the channel is chosen that minimizes the total bit error rate of the channels after the measurement. The matrices $P(k|k)$ and K are independent of the measured values and therefore it is possible to precompute the order in which the channels are going to be measured.

VIII. BIT ERROR RATE CALCULATIONS

The bit error rate is calculated for BPSK and QPSK. A matched filter receiver is assumed. The sampled output of this filter is given by

$$X_m = 2\varepsilon H_m e^{j\frac{2\pi}{M}(n-1)} + e_m \quad (10)$$

where ε is the signal energy, H_m is the current transfer function at channel m , n is the signal alternative among M sent and e_m is white gaussian noise. The bit error rate at channel m is calculated as [1]

$$P_{bmBPSK} = \frac{1}{2}(1 - \mu_m) \quad (11)$$

$$P_{bmQPSK} = \frac{1}{2} \left(1 - \frac{\mu_m}{\sqrt{2 - \mu_m^2}} \right)$$

where

$$\mu_m = \frac{E[X_m \hat{H}_m^*]}{\sqrt{E[|X_m|^2]E[|\hat{H}_m|^2]}} \quad (12)$$

\hat{H}_m are the outputs of the Kalman filter. These are not known in advance and therefore (13) - (15) are used. If matrix notation is used and signal alternative 1 is used for the pilot symbol (does affect the analysis here, but in practise different pilot symbol alternatives should be used), the expectations for all the channels can be calculated as:

$$\begin{aligned}
E[X(k)\hat{H}(k)^*] & \\
&= E[\{2\varepsilon H(k) + N(k)\}\{H(k) - \tilde{H}(k)\}^*] \\
&= 2\varepsilon E[H(k)H(k)^*] - 2\varepsilon E[H(k)\tilde{H}(k)^*]
\end{aligned} \quad (13)$$

$$\begin{aligned}
E[|X(k)|^2] &= E[\{2\varepsilon H(k) + N(k)\}\{2\varepsilon H(k) + N(k)\}^*] \\
&= 4\varepsilon^2 E[H(k)H(k)^*] + E[N(k)N(k)^*]
\end{aligned} \quad (14)$$

$$\begin{aligned}
E[|\hat{H}(k)|^2] &= E[\{H(k) - \tilde{H}(k)\}\{H(k) - \tilde{H}(k)\}^*] \\
&= E[H(k)H(k)^*] - 2E[H(k)\tilde{H}(k)^*] + E[\tilde{H}(k)\tilde{H}(k)^*]
\end{aligned} \quad (15)$$

The expected values $E[X(k)\hat{H}(k)^*]$, $E[|X(k)|^2]$ and $E[|\hat{H}(k)|^2]$ are independent of the measured values but dependent upon which channels that are measured. Therefore they are time dependent. The expectations can be calculated as:

$$\begin{aligned}
E[H(k)H(k)^*] & \\
&= E[\{\phi H(k-1) + v(k-1)\}\{\phi H(k-1) + v(k-1)\}^*] \\
&= \phi^2 E[H(k-1)H(k-1)^*] + E[v(k-1)v(k-1)^*] \\
&= R_1/(1-\phi^2)
\end{aligned} \quad (16)$$

$$E[N(k)N(k)^*] = R_2 \quad (17)$$

$$\begin{aligned}
E[H(k)\tilde{H}(k|k)^*] &= E[H(k)H(k)^* - H(k)\hat{H}(k|k)^*] \\
&= E[\phi H(k-1)\tilde{H}(k-1)^*\phi^* + R_1 - R_1 C(k)^* a^* \\
&\quad - \phi H(k-1)\tilde{H}(k-1)^*\phi^* C(k)^* a^*] \\
&= (\phi E[H(k-1)\tilde{H}(k-1)^*]\phi^* + R_1)(I - C(k)^* a^*)
\end{aligned} \quad (18)$$

where

$$E[\tilde{H}(k|k)\tilde{H}(k|k)^*] = P(k|k) \quad (19)$$

$$a = P(k|k-1)C(k)^*\{C(k)P(k|k-1)C(k)^* + R_2\}^{-1} \quad (20)$$

The bit error rate calculation is compared and verified by simulations. Proakis [1] gives expressions for the bit error rate when estimating a constant Rayleigh channel using different numbers of pilot symbols, see Fig. 11.

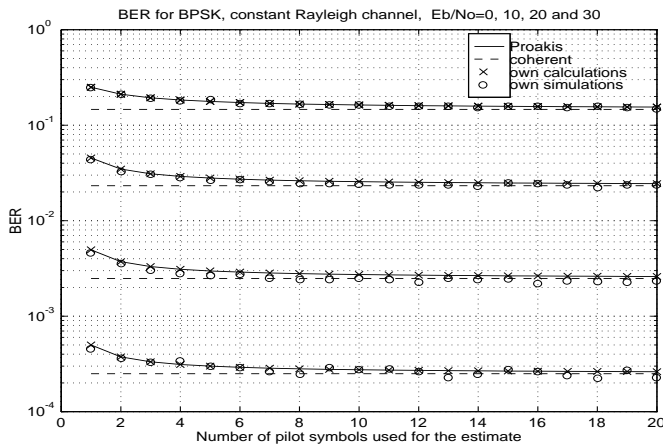

Fig. 11 Bit error rate for 2PSK when estimating a constant Rayleigh channel with several pilot symbols at different signal to noise ratios.

The bit error rate when using only one pilot symbol corresponds to estimating a rapidly changing channel or the first estimate of an unknown channel. Then, only the latest mea-

surement is useful. In a similar way, the bit error rate when estimating a constant channel with use of (infinitely) many pilot symbols corresponds to that of coherent detection. Normally in a practical system the effect of the estimation is somewhere between these two cases.

IX. CONCLUSIONS

The bit error rate for pilot assisted QPSK modulation is calculated when using different pilot patterns. The ability to estimate the channel reliably when it changes due to e.g. vehicle movements is highly dependent on the pilot pattern used. By rearranging the pilot pattern it is, in some cases, possible to handle 10 times higher Doppler frequency alternatively possible to reduce the number of needed pilot symbols the same amount, still retaining the same bit error rate. Alternatively the new pilot pattern could be used to reduce the bit error rate up to a factor 5, even more in a low noise environment. The pilot symbols in the proposed pilot pattern are spread out both in time and frequency. For a given propagation environment, e.g. a base station site, it is possible to pre-calculate a suitable pilot pattern.

REFERENCES

- [1] J. G. Proakis, Digital Communications, third edition, McGraw-Hill, USA, 1995.
- [2] European Telecommunications Standard Institute, GSM 05.05, version 4.6.0, July 1993.
- [3] J. M. Mendel, Lessons in Estimation Theory for Signal Processing, Communications and Control, Prentice-Hall, USA, 1995.
- [4] M. Sandell, Design and Analysis of Estimators for Multi-carrier Modulation and Ultrasonic Imaging, Ph.D. thesis, Luleå University of Technology, Sweden, 1996.
- [5] J. K. Cavers, An Analysis of Pilot Symbol Assisted Modulation for Rayleigh Fading Channels, IEEE Trans. Vehic. Tech. vol 40, no 4, pp 686-693, nov 1991.
- [6] T. Mueller, K. Brueninghaus and H. Rohling, Performance of Coherent OFDM-CDMA for Broadband Mobile Communications, Wireless Personal Communications 2, pp 295-305, Kluwer, Netherlands, 1996.
- [7] P. Hoeher, TCM on Frequency-Selective Land-Mobile Fading Channels, Proc. of 5th Tirrenia Int. Workshop in Dig. Communications, Tirrenia, Italy, Sept. 1991.
- [8] W. Jakes, Microwave Mobile Communications, Wiley-Interscience, USA 1974

Paper II

Optimization of sub-channel bandwidth for mobile OFDM systems

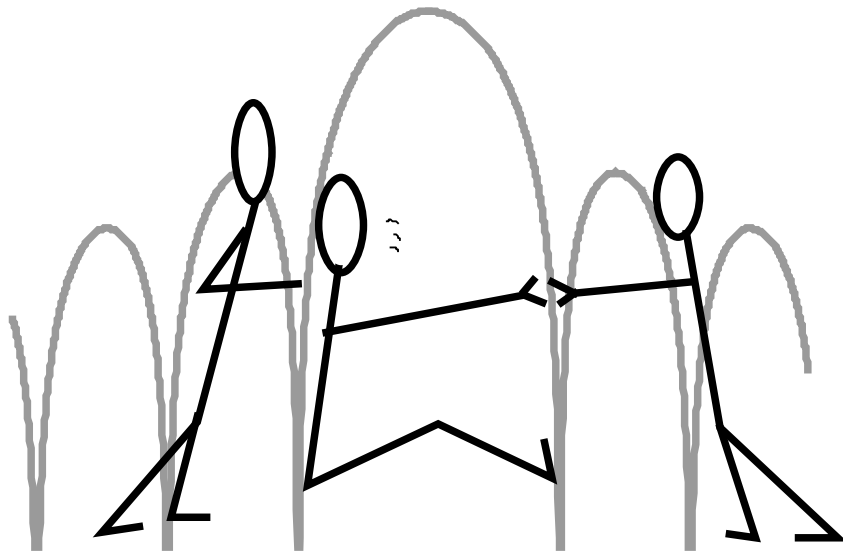

OPTIMIZATION OF SUB-CHANNEL BANDWIDTH FOR MOBILE OFDM SYSTEMS

Fredrik Tufvesson and Torleiv Maseng

*Department of Applied Electronics, Lund University,
Box 118, SE-221 00 Lund, Sweden.
E-mail: Fredrik.Tufvesson@tde.lth.se*

Abstract: The bit error rate in orthogonal frequency division multiplex (OFDM) systems is affected by the number of sub-channels used, changes in the channel characteristics and, to some extent, the excess delay of the channel. This paper presents an analytical expression for the bit error rate on Rayleigh fading channels when interchannel interference (ICI) caused by channel changes during a symbol and energy loss due to the cyclic prefix are regarded. This expression is used to optimize the number of sub-channels, and thereby the sub-channel bandwidth in the system. It is argued that the system can be optimized neglecting the effect of imperfect channel estimation and on a worst case assumption for the Doppler frequency and signal to noise ratio. The analysis is general and can be used for performance analysis and optimization of any mobile OFDM system.

INTRODUCTION

OFDM, orthogonal frequency division multiplexing, is used and proposed for several broadcast systems [1] [2] and there is a growing interest in using the technique for the next generation land mobile communication system. In OFDM systems the information signal can be seen as divided among and transmitted by several narrowband sub-carriers. The bandwidths of the sub-carriers depend on the bit rate sent on each of them and consequently, for a given total bitrate the sub-carrier bandwidth is dependent on the number of sub-channels used. The number of sub-channels used is set in the system design and the problem is to find a good trade off between bandwidth, limitations by the hardware and the physical channel. As the sub-carrier bandwidth is reduced, the symbol time on each carrier gets longer, the channel changes during a symbol gets larger and channel compensation gets more difficult. When the changes in the channel characteristics during a symbol time become evident, the orthogonality between the subchannels is lost and interchannel interference (ICI) arises. On the

other hand as the carrier bandwidth and the sub-channel symbol rate increases, intersymbol interference (ISI) becomes a problem. This problem can be avoided by introducing a cyclic prefix [3], but this results in an energy loss. In between these two extremes there exists an optimal bandwidth where the bit error rate is minimized, this bandwidth is found in this paper.

There is some previous work regarding the choice of number of sub-channels in OFDM systems, see e.g. [4] [5], but often the optimization is performed empirically or by simulation. In [4] a noncoherent OFDM DPSK system is analysed with respect to random FM noise and a frequency selective channel. It is concluded that a sub-channel bandwidth of 1.5 kHz is suitable for a bitrate of 200 kbit/s and 100 Hz Doppler frequency, but without consideration to the interchannel interference caused by channel changes during a symbol. The latter can cause severe degradation of the bit error rate if the sub-channel bandwidth is chosen too small.

SYSTEM DESCRIPTION

When designing an OFDM system one often start with a requirement on the total bit rate. Assume that a total bitrate of R_{tot} bits per second is required. If these are equally divided between the channels then the bitrate

$$R_1 = \frac{R_{tot}}{N} \quad (1)$$

is transferred on each of the N sub-channels. The symbol time for M-ary modulation on each sub-channel becomes

$$T_{sub} = \frac{\log_2 M}{R_1} = \frac{N \log_2 M}{R_{tot}}. \quad (2)$$

In the following the influence of some of the most important design parameters are discussed.

Cyclic prefix

To avoid intersymbol interference and to maintain orthogonality between the sub-channels in a time dispersive channel, a cyclic prefix can be used [3]. ISI is avoided if the length of the cyclic prefix, T_{cp} , is chosen large enough to exceed the maximum excess delay of the channel. The total symbol time, T_s , is extended when a cyclic prefix is used but the sub-channel bandwidth, Δf , is equal to the inverse of the symbol time excluding the cyclic prefix [4], T_s , see Figure 1.

$$\Delta f = \frac{1}{T_s} = \frac{1}{T_{sub} - T_{cp}} = \frac{R_{tot}}{N \log_2 M - T_{cp} R_{tot}} \quad (3)$$

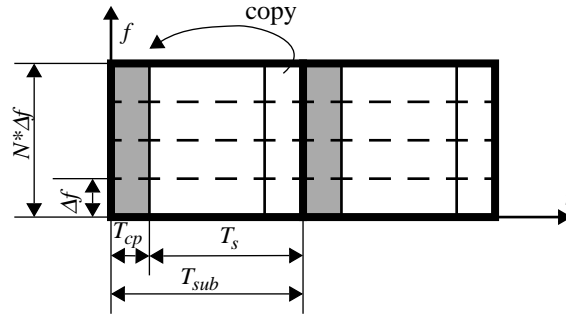

Figure 1. Eight symbols sent on four sub-channels. The striped area indicates insertion of the cyclic prefix.

Insertion of a cyclic prefix means that the sub-channel bandwidth has to be increased in order to keep the bit rate R_l constant. The bit rate determines the symbol time T_{sub} and if a part of this is used for the cyclic prefix, then the time T_s has to be shortened which in turn leads to increased sub-channel bandwidth.

The cyclic prefix also leads to a power loss, α_{cp} . The receiver uses the energy received during the time T_s and discards the energy corresponding to the duration of the cyclic prefix. The remaining signal energy can be calculated as $\alpha_{cp}E_s$ where

$$\alpha_{cp} = \frac{T_s}{T_{sub}} = 1 - \frac{T_{cp}R_{tot}}{N\log_2 M}. \quad (4)$$

Interchannel interference

Even though the channel is perfectly estimated there are some variations in the transfer function during each symbol interval. These variations becomes evident when many sub-channels are used due to the long symbol time, they are hard to track and result in interchannel interference, ICI. When the number of sub-channels is sufficiently large the resulting ICI can be modeled as additive white Gaussian noise, which is added to the channel noise [6] with spectral density N_0 . The variance of the ICI-noise, $\sigma_{ICI}^2 = E[n_{ICI}n_{ICI}^*]$, is calculated as[6]:

$$\sigma_{ICI}^2 = 2E_s \left(1 - \frac{1}{N} - \frac{2}{N^2} \sum_{n=1}^{N-1} (N-n) J_0 \left[2\pi f_D n \left(\frac{\log_2 M}{R_{tot}} - \frac{T_{cp}}{N} \right) \right] \right) \quad (5)$$

Bit error rate for coherent detection

If we neglect the effect of channel estimation errors, the equivalent signal to noise ratio after the cyclic prefix is removed and the ICI-noise is added becomes

$$\left(\frac{E_s}{N_0}\right)_{eq} = \frac{E_s \alpha_{cp}}{N_0 + \sigma_{ICI}^2}. \quad (6)$$

The BER for QPSK/4QAM in a Rayleigh fading channel with coherent detection can then be calculated as

$$p_b = \int_{y=0}^{\infty} p(y) Q\left(\sqrt{y \left(\frac{E_s}{N_0}\right)_{eq}}\right) dy = \frac{1}{2} - \frac{1}{2} \quad (7)$$

$$\sqrt{\frac{NE_s(2N - T_{cp}R_{tot})}{N^2(4N_0 + 10E_s) - NE_s(8 + T_{cp}R_{tot}) - 16E_s \sum_{n=1}^{N-1} (N-n) J_0\left[2\pi f_D n \left(\frac{\log_2 M}{R_{tot}} - \frac{T_{cp}}{N}\right)\right]}}$$

where y is the power attenuation of the channel with an exponential distribution of mean 1, i.e. $p(y) = e^{-y}$. In Figure 2 the bit error rate for coherent detection is presented for four different E_s/N_0 at 50 Hz Doppler frequency and a total bit rate of 320, 640 respectively 1280 kb/s. The reference curve represents coherent detection in a Rayleigh channel without losses due to cyclic prefix or ICI.

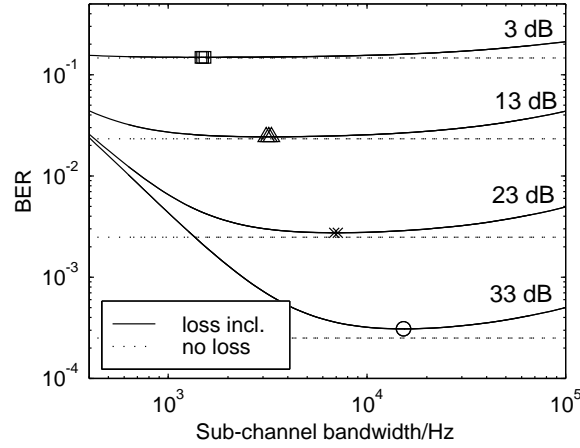

Figure 2. The BER curves for $R_{tot}=320, 640$ and 1280 kbit/s overlap each other totally in this case. Coherent QPSK is used in a Rayleigh fading channel with $T_{cp}=10 \mu s$ and $f_D=50$ Hz when the number of sub-channels and signal to noise ratio are varied. The dotted lines represent coherent detection without losses.

A cyclic prefix of duration $10 \mu s$ is chosen to combat time dispersion, a duration long enough to exceed the expected maximum excess delay of the channel. In this paper a COST 207 "Typical Urban" channel [8] is considered with an maximum excess delay of $5 \mu s$. In Figure 2 the bit error rate is shown insensitive to bitrate changes but the effect of the ICI-noise and the energy loss due to the cyclic prefix is apparent. On the right hand side few sub-channels are used, the symbol time is short and the length of

the cyclic prefix needed to suppress ISI causes a big loss of symbol energy. On the left hand side the symbol time is long, the changes in the channel characteristics during a symbol becomes significant and ICI arises. The optimal sub-channel bandwidth is sensitive to the Doppler frequency since a large Doppler frequency results in large ICI-noise and the optimum is pushed toward broader channels, see Figure 3.

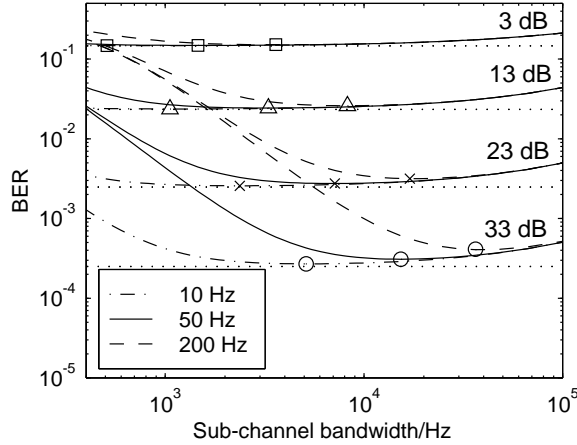

Figure 3. Bit error rate for coherent detection when the Doppler frequency is varied, $f_D = \{10, 50, 200\}$ Hz, $R_{tot} = 320$ kbit/s and $E_s/N_0 = \{3, 13, 23, 33\}$ dB. The dotted lines represent coherent detection without losses.

Channel estimation

The radio channel corrupts the transmitted signal and in order to make coherent detection possible we have to know the impact of the channel. Both the amplitude and phase are corrupted by the fading channel, whose characteristics vary because of movements of the mobile terminal. In order to keep track of the channel characteristics pilot symbol assisted modulation, PSAM, can be used. This means that known training symbols are multiplexed into the data stream at certain sub-channels and certain times. The receiver interpolates the channel information derived from the pilot symbols and makes channel estimates for the data symbols. Since the pilot symbols carry no data the pilot density is to be kept at a minimum not to increase the overhead too much. In order to make it possible for the receiver to achieve nearly maximal channel information from each of the pilots the pilot pattern can be made "balanced" [7]. This means that the spacings between the pilots are approximately the same in both frequency and time when normalized by the minimum expected coherence bandwidth and the minimum expected coherence time respectively. Few sub-channels means that we have to insert several data symbols between the pilot symbols in the time domain. Many sub-channels gives us the opportunity to use several of the channels for pilots simultaneously without increasing the pilot density, see Figure 4.

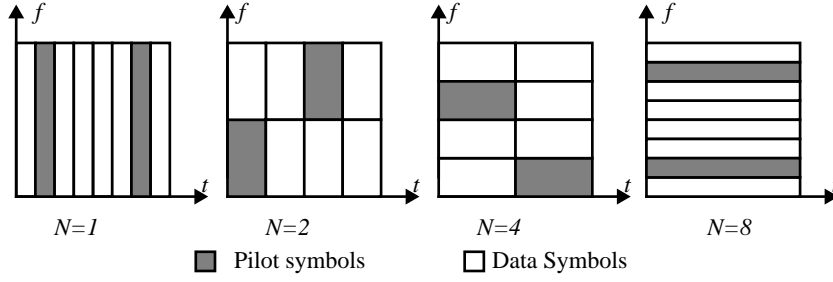

Figure 4. Time - frequency distribution of a pilot symbol differs depending on the number of sub-channels, N , used. Note that the same pilot density, $1/4$, is used for the three alternatives.

Let N_T and N_F denote the pilot time distance respectively pilot frequency distance in number of symbols, f_{Dmax} denote the maximum expected Doppler frequency (Hz) and τ_{max} denote the maximum expected excess delay (s) of the channel, then the condition for "balanced design" becomes [7]

$$f_{Dmax} \cdot T_{sub} \cdot N_T \approx \tau_{max} \cdot \Delta f \cdot N_F. \quad (8)$$

The overall pilot density is $\beta \approx \frac{1}{N_T N_F}$, and as a rule of thumb the pilot spacings can be chosen as [7]

$$f_{Dmax} \cdot T_{sub} \cdot N_T = \tau_{max} \cdot \Delta f \cdot N_F = \frac{1}{4} \quad (9)$$

An example of a pilot pattern with $N_F=4$ and $N_T=5$ is given in Figure 5.

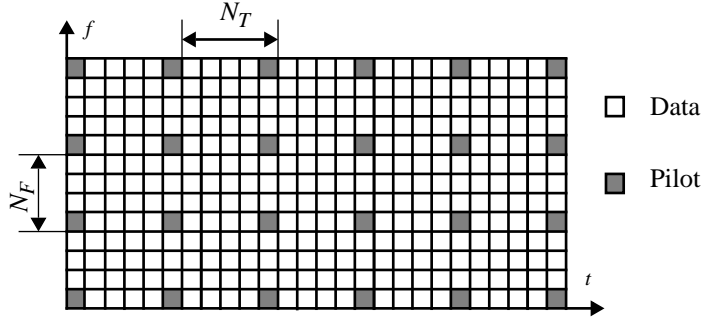

Figure 5. An example of a "balanced" pilot pattern with pilot time distance $N_T=5$ and pilot frequency distance $N_F=4$.

With a fixed time-frequency block, edge problems can arise when designing the pilot pattern. In order to get rid of this problem in the following and in order to suppress the bit error rate at the edges, pilots are put on the outer sub-channels respectively time instants and then sufficiently many pilot symbols are evenly distributed between these edge pilots in frequency respectively time in order not to exceed the pilot distances given by (9).

To see the effect of the channel estimation only, the bit error rate was calculated without ICI-noise and energy losses due to the cyclic prefix. For the estimation a two-dimensional Wiener filter [7] was used, which is optimal in the sense that the variance

of the estimation error is minimized. Furthermore, known Doppler frequency, perfect synchronization, a COST 207 "Typical Urban" channel [8] and a matched filter receiver was assumed, see Appendix A for more details. The resulting bit error rate under these assumptions with a bit rate of 320 kbit/s, 200 Hz Doppler frequency is presented in Figure 6.

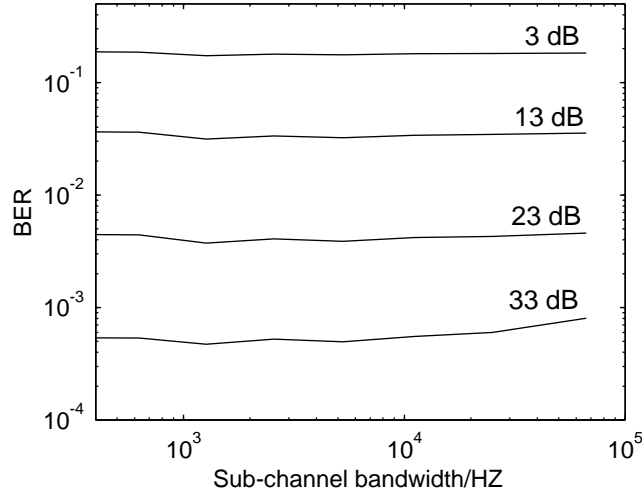

Figure 6. Changes in the bit error rate caused by the pilot pattern, $E_s/N_0 = \{3, 13, 23, 33\}$ dB. As seen, the pilot pattern has virtually no effect on the bit error rate when "balanced design" is used.

The reason why the different pilot patterns virtually do not affect the bit error rate is explained by the fact that the pilot symbols are placed at approximately the same frequencies and time instances independent of the sub-channel bandwidth and symbol time used. There are some changes in the bit error rates due to the fact that the pilot distances can not be below one, due to numerical reasons in the pilot pattern design and due to the slight increase in the total bandwidth to estimate when few channels are used, but these changes are rather small.

COMPLETE SYSTEM

In a real system the channel estimation is of course not perfect. The bit error rate when both channel estimation and the losses due to the cyclic prefix and ICI-noise are included is lower bounded by the bit error rate for coherent detection in (7) and the deviation gets smaller as the pilot density increases. The bit error rate for the same parameters as in last section ($R_{tot}=320$ kbit/s $f_D=200$ Hz, "Typical Urban" channel, $T_{cp}=10$ μ s) but with the losses included is presented in Figure 7.

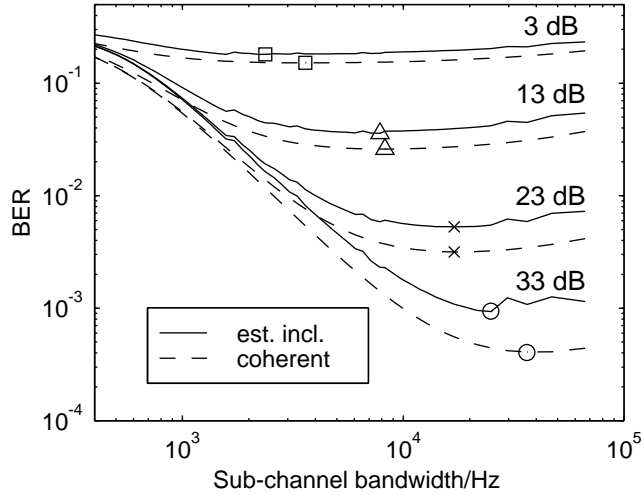

Figure 7. Bit error rate for coherent detection and for the total system when channel estimation errors are included, $E_s/N_0 = \{3, 13, 23, 33\}$ dB.

DISCUSSION

As indicated in Figure 7 it is possible to optimize the number of sub-channels and thereby the sub-channel bandwidth by assuming perfect channel estimates. The resulting optimum when channel estimation effects are included is principally unaffected by the number of sub-channels used. The reason for this is that the variance of the estimation error, see Appendix A, is approximately the same, independent of the sub-channel values chosen. This, in turn, means that it is possible to optimize the number of channels neglecting the effect of channel estimation.

More narrowband sub-channels can be used when terminal movements are slow since the channel is not expected to change during the longer symbol time. This means that the relative duration of the cyclic prefix becomes shorter and that the bandwidth expansion is kept small. However, the sub-channel bandwidth has to be optimized on a worst case assumption for the Doppler frequency, otherwise the increase in bit error rate can become severe for high Doppler values.

The optimal sub-channel bandwidth is unfortunately dependent on the signal to noise ratio. Higher noise levels call for more narrowband sub-channel since the noise makes the energy loss due to the cyclic prefix more evident. In the same way as for the Doppler frequency a worst case design has to be made with respect to the noise level. It is important to keep the maximal bit error rate as low as possible, even though this results in a larger BER increase for lower noise levels. Actually, often it is the performance of a coded system that is interesting and since the coding gives more distinct optima it is important not to increase the worst case BER.

The effect of frequency offsets is not included in the analysis and this effect becomes more significant when many narrowband sub-channels are used. The carrier to interference ratio due to frequency offsets is proportional to Δf^2 [9], thus moving the optimal sub-channel bandwidth towards broader channels when frequency offsets are present. Finally, the calculations are based on the assumption that the sub-channels are flat fading, which may not be the case when broadband sub-channels are used in some channels, e.g. hilly terrain.

CONCLUSIONS

The impact of the number of sub-channels, and thereby the sub-channel bandwidth, used in a mobile OFDM-system was analysed. An analytical expression for the bit error rate in Rayleigh fading channels was presented where the impact of the cyclic prefix and the channel changes during a symbol time are encountered. This BER showed an optimum for the sub-channel bandwidth to be used depending on Doppler frequency, length of cyclic prefix and signal to noise ratio. The effect of channel estimation on the optimum was also examined and this showed that the optimization can be performed on the coherent system, without taking the channel estimation into account. The excess delay of the channel, high noise levels and efficient usage of the spectrum call for many narrowband sub-channels while a rapidly moving terminal call for the use of fewer more broadband sub-channels. Finally it was argued that the sub-channel bandwidth has to be designed on a worst case assumption for the Doppler frequency and the signal to noise ratio.

Appendix A. System models

In the following section the channel model, estimation algorithm and bit error rate calculations are presented in detail.

The time dependent channel impulse response, $h(\tau, t)$, is assumed to be a sum of reflections, see (A.1) where $\delta(t)$ denotes the dirac-function.

$$h(\tau, t) = \sum_{n=1}^N a_n(t) \cdot \delta(t - \tau_n) \quad (\text{A.1})$$

The tap coefficients, $a_n(t)$, and the tap delays, τ_n , are chosen according to the COST 207 "Typical Urban" model in the GSM specification [8]. The transfer functions, $H(f, t)$, are obtained by the Fourier transform of (A.1) and these are the functions we want to estimate for the different carriers. These channel transfer functions are regarded as flat fading.

For the estimation and analysis a two-dimensional Wiener filter [7] is used, which is optimal in the sense that the variance of the reconstruction error is minimized. The sampled signal from the matched filter receiver of a pilot symbol at channel m in time k is given by

$$X_m^k = E_s H_m^k e^{j\frac{2\pi}{M}(p-1)} + n_m^k \quad (\text{A.2})$$

where E_s is the signal energy, p is the signal alternative sent among the M possible ones and n is white Gaussian noise. The noise terms have a variance given by (7), but the covariance matrix $R_e^k = E[n^k (n^k)^*]$ is not diagonal due to the correlation between the channels introduced by the ICI. The filter coefficients are given by

$$\omega_m^k = ((\theta_m^k)^T \phi^{-1})^T \quad (\text{A.3})$$

where $\phi = E[XX^*]$ is the covariance matrix for the received pilot symbols and $\theta_m^k = E[H_m^k(X_m^k)^*]$ is a cross-covariance vector between the transfer function to be estimated and the received pilot symbols. The estimates of the channel transfer functions can then be calculated as

$$\hat{H}_m^k = (\omega_m^k)^T X \quad (\text{A.4})$$

where X is a vector of the sampled values from all of the pilot symbols. Finally, the mean square error of the estimates is calculated as

$$J_m^k = \sigma_H^2 - (\theta_m^k)^T \phi^{-1} (\theta_m^k)^* \quad (\text{A.5})$$

and this matrix is in turn used to calculate the QPSK bit error rate for each of the symbols. The BER is given by [10] [11]

$$P_b = \frac{1}{2} - \frac{\mu}{2\sqrt{2 - \mu^2}} \quad (\text{A.6})$$

where

$$\mu = E_s \frac{\sigma_H^2}{\sqrt{(\sigma_H^2 + \sigma_e^2)(\sigma_H^2 + J)}}. \quad (\text{A.7})$$

References

- [1] "Digital broadcasting systems for television, sound and data services". European telecommunications standards institute, prETS 300 744, Valbonne, France, 1996
- [2] "Radio broadcasting systems; Digital Audio Broadcasting (DAB) to mobile, portable and fixed receivers. European telecommunications standards institute, ETS 300 401, Valbonne, France, 1995
- [3] A. Peled and A. Ruiz, "Frequency domain data transmission using reduced computational complexity algorithms", Proc. IEEE Int. Conference Acoustics, speech, signal processing, Denver, USA, pp 964-967, 1980
- [4] S. Hara, M. Mouri, M. Okada and N. Morinaga, "Transmission performance analysis of multi-carrier modulation in frequency selective fast Rayleigh fading channel", Wireless Personal Communications, nr 2, Kluwer Academic Publishers, Dordrecht, Netherlands, pp 335-356, 1996
- [5] M. Wahlqvist, C. Östberg, J.-J. van de Beek, O. Edfors and P. O. Börjesson, "A conceptual study of OFDM-based multiple access schemes: Part 1 - Air interface requirements. Technical report Tdoc 116/96 ETSI STC SMG2 meeting no 18, Helsinki, Finland, May 1996
- [6] M. Russell and G. L. Stüber, "Terrestrial digital video broadcasting for mobile reception using OFDM", Wireless Personal Communications, vol 2, nr 1-2, Kluwer Academic Publishers, Dordrecht, The Netherlands, pp 45-66, 1995
- [7] P. Hoeher, S. Kaiser and P. Robertson, "Pilot-symbol-aided channel estimation in time and frequency", In K. Fazel and G. P. Fettweis, editors, Multi-Carrier Spread-Spectrum, chapter IV, pp 169-178. Kluwer Academic Publishers, Dordrecht, The Netherlands, 1997.
- [8] European Telecommunications Standard Institute, "GSM 05.05", version 4.6.0, July 1993.
- [9] Y. Zhao and S.-G. Häggman, "Sensitivity to Doppler shift and carrier frequency errors in OFDM systems -- The consequences and solutions", IEEE Vehicular Technology Conference, Atlanta, USA, April 29 - May 2, pp. 1564-1568, 1996.
- [10] S. K. Wilson, "Digital audio broadcasting in a fading and dispersive channel", Ph.D. thesis, Stanford University, USA, 1994.
- [11] J. G. Proakis, "Digital communications", third edition, McGraw-Hill, New York, USA, 1995.

Paper III

Theoretical analysis of pre-compensation for Rayleigh fading channels in QPSK TDD systems

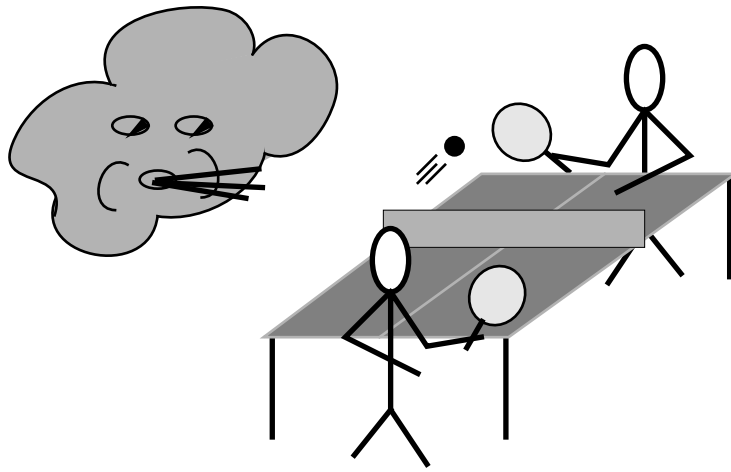

Theoretical Analysis of Pre-Compensation for Rayleigh Fading Channels in QPSK TDD Systems

Fredrik Tufvesson, Michael Faulkner and Torleiv Maseng

Abstract – In time division duplex systems the uplink channel estimate can be used for compensating the channel impact on the downlink symbols. Three different methods where amplitude and/or phase are adjusted are analyzed in terms of performance limits. Closed-form expressions for the QPSK BER are given assuming a fully known channel. Pre-compensation (precoding) is an attractive alternative to differential decoding. Phase-only compensation is preferred at low E_b/N_o , because there is no increase in transmitter dynamics, while at high E_b/N_o an order of magnitude improvement in the BER can be obtained by including amplitude pre-compensation.

I. Introduction

For digital radio transmission either differential or coherent detection can be used. Differential detection can be used with a low complexity receiver, but has a reduced performance compared to coherent schemes. Coherent detection results in lower bit error rates, BER, but the receiver becomes complex due to the need for channel estimation. In time division duplex, TDD, systems the same radio channel is used both for uplink and downlink transmission. This leads to the possibility of using an uplink channel estimate to pre-compensate (also called precode) the symbols to be transmitted on the downlink. This is performed by filtering the signal to be transmitted by the inverse channel response. Then the received signal can be demodulated directly without channel estimation nor equalization nor coherent carrier recovery. This means that a simple receiver structure can be used (similar complexity to differential detection), while still maintaining the performance benefits of coherent detection [1]. This also applies to systems using multilevel modulation, such as 16- and 64-QAM, which normally require channel estimation in the mobile terminal.

In [2] an amplitude pre-compensated noncoherent FSK system was analyzed and this showed a possible reduction of 3 dB in transmitted power at high SNR values, or a reduction on BER by a factor five. In this paper the theoretical performances of three pre-compensated QPSK TDD systems are compared when the channel is assumed to be known. In a practical system this is of course not true and the results presented here are best case. But, if the channel is assumed to be reciprocal and the blocklength in the TDD structure is short compared to the fading period, then reliable channel estimates can be made and a pre-compensated system is possible.

II. System

The channel is described by a phase shift, θ , and a power gain, y . The received signal may be represented by [3]

$$r(t) = \sqrt{y(t)}e^{j\theta(t)}s(t) + n(t) \quad (1)$$

where $s(t)$ is the transmitted signal and $n(t)$ is white Gaussian noise. In the following a flat Rayleigh fading channel which is constant during a symbol time is considered.

Three compensation methods are evaluated:

1. Phase compensation only, the transmitter phase is altered by $-\theta$ radians.
2. Phase and amplitude compention when $y > a_2$, otherwise no transmission. The transmitter output is inhibited when the path attenuation exceeds the threshold a_2 .
3. Phase and amplitude compensation when $y > a_3$, otherwise power limiting. The transmitter output saturates when the path attenuation exceeds the threshold a_3 .

The base station makes estimates of the channel amplitude and channel phase e.g. by use of known pilot symbols on the uplink. Then the signal to be sent is compensated. If we let $u_m'(t)$ denote the uncompensated equivalent lowpass waveforms [3], then the equivalent lowpass waveforms for the compensated sent signals are

$$(u_m(t))_1 = e^{-j\theta} u_m'(t) \quad (2)$$

$$(u_m(t))_2 = \begin{cases} 0 & y < a_2 \\ \sqrt{\frac{\eta_2}{y}} e^{-j\theta} u_m'(t) & y \geq a_2 \end{cases} \quad (3)$$

$$(u_m(t))_3 = \begin{cases} \sqrt{\frac{\eta_3}{a_3}} e^{-j\theta} u_m'(t) & y < a_3 \\ \sqrt{\frac{\eta_3}{y}} e^{-j\theta} u_m'(t) & y \geq a_3 \end{cases} \quad (4)$$

where η_2 and η_3 are power normalization coefficients. The probability density function of power gain, y , in a Rayleigh channel with unity mean is $p_Y(y) = e^{-y}$. Hence, if the channel is perfectly estimated and E_m' denotes the symbol energy before compensation, then the mean transmitted symbol energies are

$$(\overline{E_m})_1 = E_m' \quad (5)$$

$$(\overline{E_m})_2 = \int_{a_2}^{\infty} \frac{\eta_2}{y} E_m' e^{-y} dy = \eta_2 E_m' \int_{a_2}^{\infty} \frac{e^{-y}}{y} dy \quad (6)$$

$$\begin{aligned} (\overline{E_m})_3 &= \int_0^{a_3} \frac{\eta_3}{a_3} e^{-y} E_m' dy + \int_{a_3}^{\infty} \frac{\eta_3}{y} e^{-y} E_m' dy \\ &= \eta_3 E_m' \left(\frac{1}{a_3} (1 - e^{-a_3}) + \int_{a_3}^{\infty} \frac{e^{-y}}{y} dy \right) \end{aligned} \quad (7)$$

In order to maintain the same transmitted mean energy for the three methods, the power normalization coefficients are consequently chosen as

$$\eta_2 = 1/\left(\int_{a_2}^{\infty} \frac{e^{-y}}{y} dy\right) \quad \eta_3 = 1/\left(\frac{1}{a_3}(1 - e^{-a_3}) + \int_{a_3}^{\infty} \frac{e^{-y}}{y} dy\right) \quad (8)$$

The instantaneous received symbol energy at the mobile terminal for the three compensation methods becomes

$$(E_m)_1 = yE_m' \quad (9)$$

$$(E_m)_2 = \begin{cases} 0 & y < a_2 \\ \eta_2 E_m' & y \geq a_2 \end{cases} \quad (10)$$

$$(E_m)_3 = \begin{cases} \frac{y}{a_3} \eta_3 E_m' & y < a_3 \\ \eta_3 E_m' & y \geq a_3 \end{cases} \quad (11)$$

With QPSK the bit energy before compensation is $E_b' = \frac{1}{2}E_m'$. The bit error rate, P_b , when the Rayleigh fading channel is perfectly known is for the first method the same as for ordinary coherent detection of QPSK signals, i.e. [3]

$$(P_b)_1 = \int_0^{\infty} Q\left(\sqrt{y \frac{2E_b'}{N_0}}\right) p_Y(y) dy = \frac{1}{2} \left(1 - \sqrt{\frac{E_b'/N_0}{1 + E_b'/N_0}}\right) \quad (12)$$

The bit error rate for the two other methods can be calculated as

$$\begin{aligned} (P_b)_2 &= \int_0^{a_2} \frac{1}{2} p_Y(y) dy + \int_{a_2}^{\infty} Q\left(\sqrt{\eta_2 \frac{2E_b'}{N_0}}\right) p_Y(y) dy \\ &= \frac{1}{2} (1 - e^{-a_2}) + e^{-a_2} Q\left(\sqrt{\eta_2 \frac{2E_b'}{N_0}}\right) \end{aligned} \quad (13)$$

$$\begin{aligned} (P_b)_3 &= \int_0^{a_3} Q\left(\sqrt{y \frac{\eta_3 2E_b'}{a_3 N_0}}\right) p_Y(y) dy + \int_{a_3}^{\infty} Q\left(\sqrt{\eta_3 \frac{2E_b'}{N_0}}\right) p_Y(y) dy \\ &= \frac{1}{2} + \frac{\eta_3 (E_b'/N_0)}{\sqrt{a_3 + \eta_3 (E_b'/N_0)}} \left[Q\left(\sqrt{2a_3 + \eta_3 \frac{2E_b'}{N_0}}\right) - \frac{1}{2} \right] \end{aligned} \quad (14)$$

The resulting BER is shown in Fig. 1 together with the curves for differential QPSK [3]. On the left side of the figure too much energy is spent on compensating very bad channels, while on the right side the transmitter is saturated or off even when communication normally is advisable.

The compensation limits, a_2 and a_3 , can be seen as a measure of the dynamic range for the power compensation. However, in practical measurements the peak-to-average ratio of the transmitted power is often used, which for the pre-compensation methods is the product of the peak-to-average ratio of the modulation method and the increase due to the compensation. The latter is shown in Fig. 2, and can be calculated as 1 , η_2/a_2 and η_3/a_3 for the three methods respectively.

IV. Discussion

Phase-only compensation produces no increase in peak-to-average power ratio of the transmitted signal, a favorable property for power amplifiers. The bit error rate is the same as would be expected from a standard receiver with coherent demodulation, which is approximately half that obtained from differential detection. At low E_b/N_0 values phase-only correction appears to be best for the majority of a -values. At medium and high E_b/N_0 there is some value in adding amplitude compensation with peak power saturation, particularly for practical values of peak to average transmitter power increase (up to 10 dB). Switching off the transmitter instead of saturating at the peaks to save power when the channel is poor, appears to be only marginally viable at impracticably large peak to average power ratios, and therefore should not be considered. The performance of this latter scheme is dominated by the on/off duty cycle of the transmitter which explains the merging of the curves for high values of the compensation limit, a . In comparison with differential decoding (where the terminals have approximately the same complexity) all the compensation methods perform well for appropriate compensation limits. The presented BER curves apply for both single- and multicarrier systems (i.e. OFDM) and when both phase and amplitude are compensated the technique can be extended to QAM systems as well.

V. Conclusions

BER when applying different methods of pre-compensating QPSK signals in a Rayleigh fading channel is presented. It is shown that pre-compensation can be an attractive alternative to differential decoding, even when only phase is compensated and the amplitude is left unaffected. If an additional 10 dB of signal variation is acceptable the bit error rate can be reduced by an order of magnitude compared to traditional coherent detection and be reduced by a factor of twenty compared to differential detection ($E_b/N_0=20$ dB).

References

- [1] P. S. Henry and B. S. Glance, "A new approach to high-capacity digital mobile radio", *The Bell system technical journal*, Vol. 60, No. 8, pp. 1891-1904, 1981.
- [2] H. Matsuki and H. Takanashi, "Theoretical analysis of BER improvement by adaptive transmitter power control for Rayleigh fading compensation", *Electronics Letters*, 29, (17), pp. 1520-1521, 1993.
- [3] J. G. Proakis, *Digital communications*, third edition, McGraw-Hill, New York, USA, 1995.

Figures

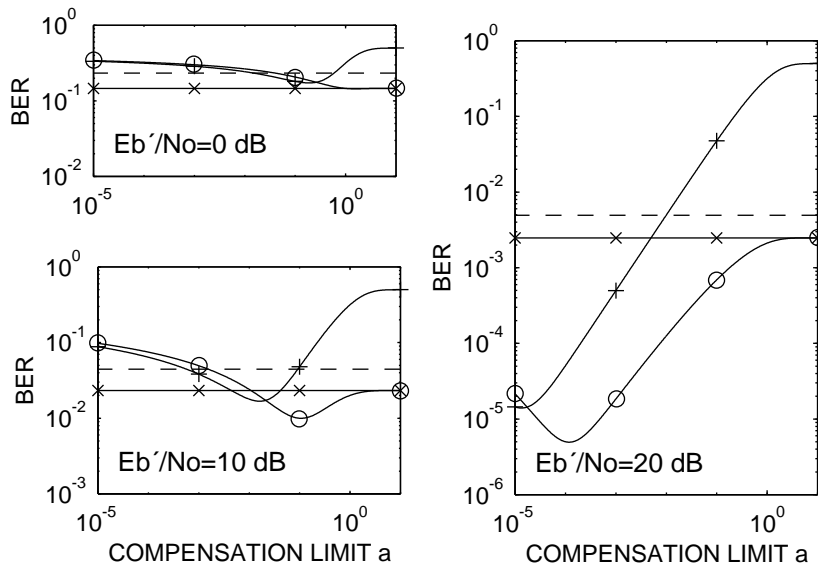

Fig. 1. BER for the compensation methods when the channel is perfectly known, $E_b'/N_o = 0, 10$ and 20 dB.

- - - differential
- x method 1, phase compensation only.
- + method 2, Tx off when $y < a_2$.
- o method 3, Tx saturated when $y < a_3$.

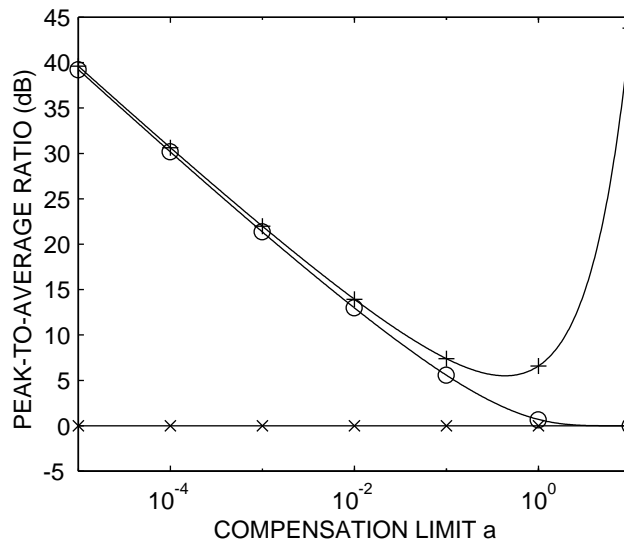

Fig. 2. Increase in peak to average power ratio for the three compensation methods.

- x method 1, phase compensation only.
- + method 2, Tx off when $y < a_2$.
- o method 3, Tx saturated when $y < a_3$.

