



LUND UNIVERSITY

Radiative lifetimes of GdI and GdII

Xu, Huailiang; Jiang, ZK; Svanberg, Sune

Published in:

Journal of Physics B: Atomic, Molecular and Optical Physics

DOI:

[10.1088/0953-4075/36/3/301](https://doi.org/10.1088/0953-4075/36/3/301)

2003

[Link to publication](#)

Citation for published version (APA):

Xu, H., Jiang, ZK., & Svanberg, S. (2003). Radiative lifetimes of GdI and GdII. *Journal of Physics B: Atomic, Molecular and Optical Physics*, 36(3), 411-417. <https://doi.org/10.1088/0953-4075/36/3/301>

Total number of authors:

3

General rights

Unless other specific re-use rights are stated the following general rights apply:

Copyright and moral rights for the publications made accessible in the public portal are retained by the authors and/or other copyright owners and it is a condition of accessing publications that users recognise and abide by the legal requirements associated with these rights.

- Users may download and print one copy of any publication from the public portal for the purpose of private study or research.
- You may not further distribute the material or use it for any profit-making activity or commercial gain
- You may freely distribute the URL identifying the publication in the public portal

Read more about Creative commons licenses: <https://creativecommons.org/licenses/>

Take down policy

If you believe that this document breaches copyright please contact us providing details, and we will remove access to the work immediately and investigate your claim.

LUND UNIVERSITY

PO Box 117
221 00 Lund
+46 46-222 00 00

Radiative lifetimes of Gd I and Gd II

This article has been downloaded from IOPscience. Please scroll down to see the full text article.

2003 J. Phys. B: At. Mol. Opt. Phys. 36 411

(<http://iopscience.iop.org/0953-4075/36/3/301>)

View [the table of contents for this issue](#), or go to the [journal homepage](#) for more

Download details:

IP Address: 130.235.188.104

The article was downloaded on 01/07/2011 at 08:08

Please note that [terms and conditions apply](#).

Radiative lifetimes of Gd I and Gd II

Huailiang Xu^{1,2}, Zhankui Jiang^{1,2} and Sune Svanberg¹

¹ Department of Physics, Lund Institute of Technology, PO Box 118, S-221 00 Lund, Sweden

² Department of Physics, Jilin University, Changchun 130023, People's Republic of China

E-mail: huailiang.xu@fysik.lth.se

Received 19 August 2002, in final form 16 December 2002

Published 16 January 2003

Online at stacks.iop.org/JPhysB/36/411

Abstract

Natural radiative lifetimes of 25 even-parity levels in Gd I ($4f^7 5d^2 6p$, $4f^7 5d 6s 6p$ and $4f^8 5d 6s$ configurations) and 13 even-parity levels in Gd II ($4f^7 5d 6p$ and $4f^7 6s 6p$ configurations) have been measured using the time-resolved laser-induced fluorescence technique in a laser-induced gadolinium plasma. The Gd I and Gd II levels range in energy from 26 866 to 36 395 cm^{-1} , and 25 960 to 42 746 cm^{-1} , respectively. In the measurements, stimulated Brillouin scattering techniques were employed to produce 1 ns laser pulses to enable accurate measurements of short-lived states. The uncertainty of the radiative lifetimes is, with a few exceptions, about $\pm 5\%$.

1. Introduction

The lanthanide elements are of importance in astrophysical investigations due mainly to their high cosmic abundance and richness in spectral lines. Evaluation and extraction of information from stellar spectra require knowledge about radiative parameters of the lanthanide elements, such as radiative lifetimes, branching ratios and oscillator strengths, which can be used for studies of elemental abundances (Mathys and Cowley 1992, Biémont *et al* 1998). Besides the astrophysical aspects, the studies of radiative parameters of the lanthanide elements are also of great interest in many other fields, such as laser chemistry, atomic and plasma physics and light-source technology.

Gadolinium ($Z = 64$) is an even- Z lanthanide element, which has been observed in spectra of a variety of stellar objects: the Sun (Spector 1970), the galactic disc (Andrievsky *et al* 2001), the Si star HD 43819 (Poli *et al* 1987), the Ap star HD 215038 (Rice 1978) and the peculiar A star HD 25354 (Pyper 1976). This has stimulated a lot of work concerning the radiative parameters of gadolinium in recent years. However, reported data on radiative lifetimes, which constitute very fundamental spectroscopic characteristics of atomic and ionic species, are incomplete; in particular, radiative lifetimes of Gd I and Gd II for many even-parity high-lying excited states remain to be explored. For this reason, we have undertaken the present experimental investigation of radiative lifetimes for neutral and singly ionized gadolinium atoms, and have extended the lifetime data considerably.

Previously, Marek and Stahnke (1980) presented 16 even-parity lifetimes (between 17 380 and 27 337 cm^{-1}) of Gd I, measured with the delayed-coincidence method with laser excitation. Mishin and Fedoseev (1983) measured three odd-parity lifetimes of Gd I, using multi-step resonance ionization spectroscopy. Lifetime measurement results on 16 levels of Gd I (between 22 334 and 29 452 cm^{-1}) and six levels of Gd II (between 26 211 and 30 102 cm^{-1}) were reported by Gorshkov *et al* (1983), Gorshkov and Komarovshii (1986), using the delayed-coincidence technique with crossing atomic and electron beams. Later on, Bergström *et al* (1988) published three lifetimes of Gd II, in the range from 29 242 to 30 102 cm^{-1} , employing a time-resolved laser-induced fluorescence (LIF) technique on a hollow-cathode discharge. Miyabe *et al* (1997) reported the lifetimes of Gd I for ten even states in the 16 061–18 510 cm^{-1} region and 64 odd states in the 31 064–36 361 cm^{-1} region, using three-step resonance ionization spectroscopy. Recently, radiative lifetimes of 20 levels (29 045–34 179 cm^{-1}) in Gd II and five levels (43 019–48 340 cm^{-1}) in Gd III (Zhang *et al* 2001) have been measured by time-resolved LIF techniques.

In this paper, we report radiative lifetime measurements on 25 even-parity levels of Gd I, in the energy range from 26 866 to 36 395 cm^{-1} , and 13 even-parity levels of Gd II, in the 25 960–42 746 cm^{-1} region. Since the analysis of the stellar spectra relies strongly upon the availability of atomic data, the present experiments were performed using time-resolved LIF techniques, which have been proven to constitute an accurate measurement method for determination of radiative lifetimes. In the present study, stimulated Brillouin scattering (SBS) techniques (Li *et al* 1999) were used to obtain 1 ns laser pulses, in order to allow the measurements of short-lived states. Stimulated Stokes Raman scattering (SSRS) in hydrogen gas was also employed, for extending the tunable range of the exciting dye laser source. Free gadolinium atoms and ions were produced in a laser-induced plasma. The states under investigation were selectively excited, and the subsequent fluorescence signal was monitored with a fast detection system.

2. Experimental set-up

Figure 1 schematically shows the experimental set-up used in the lifetime measurements. Free neutral and singly ionized gadolinium atoms were produced in a laser-produced ablation plasma. A pure gadolinium foil was put on a rotating target in a vacuum chamber, in which the pressure was about 10^{-6} – 10^{-5} mbar. The ablation laser pulses, characterized by a 532 nm wavelength, a 10 Hz repetition rate and 10 ns duration, were emitted from a Nd:YAG laser (Continuum Surelite) with variable pulse energy. Pulse energies in the range 2–10 mJ were normally used. The pulses were sent from the top of the vacuum system through a glass window, and were focused vertically onto the surface of the rotated gadolinium foil. After the impinging of the laser pulse on the gadolinium foil, the plasma, with sufficient populations in ground as well as metastable states of neutral and singly ionized gadolinium atoms, expanded from the foil for appropriately chosen plasma conditions. When the plasma reached the interaction zone, about 10 mm above the rotating target surface, it was crossed at right angles by an excitation laser beam, which was provided by a tunable nanosecond laser system.

The laser system consists of an injection-seeded and *Q*-switched Nd:YAG laser (Continuum NY-82), an SBS compressor, a dye laser (Continuum Nd-60), a potassium dihydrogen phosphate (KDP) crystal, a retarding plate, a β -barium borate (BBO) crystal and an SSRS cell. A 532 nm beam from the Nd:YAG laser with a 8 ns pulse duration, a single pulse energy of 400 mJ and a repetition rate of 10 Hz was first sent to the SBS compressor to shorten the pulse to about 1 ns, and then the shortened laser pulse was employed to pump the dye laser, in which DCM dye was operated in the wavelength range from 607 to 676 nm. Depending on

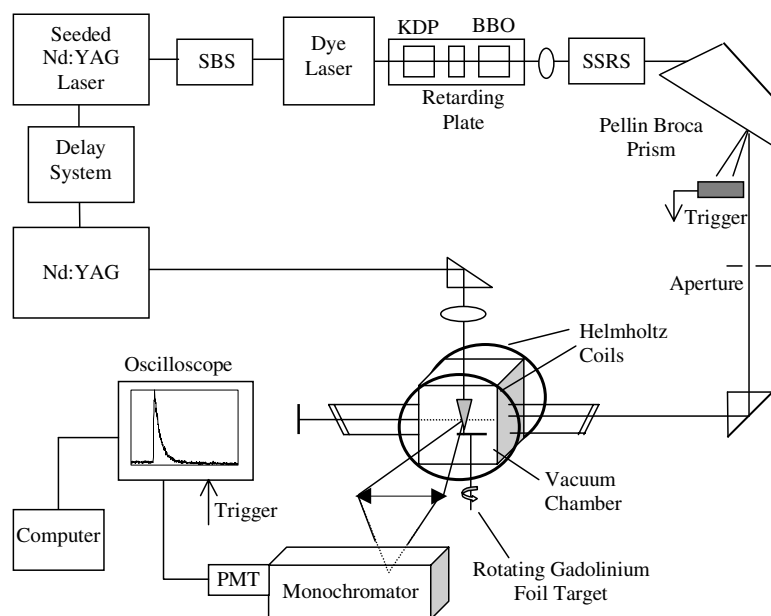

Figure 1. Experimental set-up for time-resolved LIF measurements on gadolinium.

the excitation requirements, different nonlinear processes have been adopted in this experiment to obtain the UV radiation at wavelength from 233 to 386 nm. The radiation from the dye laser could be frequency doubled in a KDP crystal, and then mixed with the fundamental frequency in a BBO crystal to produce the third harmonic of the dye laser frequency. The retarding plate was placed between the KDP and BBO crystals for polarization rotation (Bengtsson *et al* 1990). In order to extend the tunable laser range, the second harmonic, or the third harmonic of the dye laser beam was focused into the SSRS cell with hydrogen at 10 bar, in which different orders of stimulated Stokes and anti-Stokes Raman scattering were obtained. The different components of the laser beams from the SSRS cell were first isolated with a CaF₂ Pellin–Broca prism, and then the appropriate excitation light was horizontally sent into the vacuum chamber and crossed with the expanding laser-induced plasma.

Both Nd:YAG lasers were externally triggered by the same digital delay generator (Stanford Research Systems model 535). This enables a free variation of the delay time between the ablation and excitation laser pulses.

The fluorescence, decaying from the excited levels, was collected by a fused-silica lens and focused to the entrance slit of a 1/8 m monochromator (resolution 6.4 nm mm⁻¹), which was used as a filter to choose a desired fluorescence line and block stray light. A Hamamatsu 1564U micro-channel-plate (MCP) photomultiplier tube (200 ps rise time and 200–600 nm spectral response region) was employed to detect the fluorescent light selected by the monochromator. A transient digitizer (Tektronix model DSA 602), which was triggered by a Thorlabs SV2-FC photo-diode (120 ps rise time), driven by a reflection from the excitation laser beam, was used to record and average the signals from the MCP. Finally the averaged time-resolved fluorescence signals were transferred to a personal computer, where lifetime evaluations were performed immediately.

3. Measurements and results

The element gadolinium has a rather complex electronic structure with a half-full 4f electron shell and the presence of a 5d electron. The ground electronic configurations (odd parity) of the Gd I and Gd II are $4f^7 5d 6s^2$ and $4f^7 5d 6s$, respectively. Through one-photon excitations from the ground state and appropriate metastable states, the radiative lifetimes of 25 even-parity levels of Gd I, belonging to the $4f^7 5d^2 6p$, $4f^7 5d 6s 6p$ and $4f^8 5d 6s$ configurations, and of 13 even-parity levels of Gd II, belonging to the $4f^7 5d 6p$ and $4f^7 6s 6p$ configurations, were measured. The energy levels used in the present work were obtained from the NIST atomic spectrum database (<http://www.physics.nist.gov/cgi-bin/AtData/main.asd>). The levels measured are summarized in table 1, with excitation schemes indicated.

In the measurements, fluorescence signals in the different decay channels, from excited upper levels to possible lower levels, were checked in order to ensure that the Gd I and Gd II transitions of interest were indeed studied. The strongest one of the fluorescence signals was usually recorded and used for the evaluation of the radiative lifetime.

Systematic influences in the lifetime measurements can potentially affect the accuracy of the measured lifetimes. In our experiments, special attention has been given to all possible systematic effects, such as flight-out-of-view effects, radiation trapping and collisional effects, on fluorescence decay curves, by adjusting a variety of experimental conditions.

The plasma density and atomic/ionic speeds at the observed spot can be adjusted by changing the ablation pulse energy, the size of the focused ablation pulse on the foil, the distance above the target surface and the delay time between the ablation and excitation pulses. To check the collisional quenching and radiation trapping effects, measurements under different plasma conditions were performed. The delay time between the ablation pulse and the excitation pulse could be as long as $35 \mu\text{s}$ for Gd I measurements and $6 \mu\text{s}$ for Gd II, but still reasonably good signals for evaluating the lifetime were obtained. Though the detected fluorescence intensity varied by a factor of ten, the lifetime values were found to be well coincident. This indicated that radiation trapping and collisional quenching effects were negligible under our measurement conditions. The longer delay time interval for Gd I than for Gd II is easily understood due to the lower speeds of atoms compared to ions. When collisions are negligible, alignment effects resulting from the polarization of the excitation laser do not influence the time evolution of the fluorescence signal (Schade *et al* 1993).

In this experiment, a pair of Helmholtz coils provided about 100 G static magnetic field to wash out quantum beats due to the Zeeman effects for long-lived states. It is well known that flight-out-of-view effects are important in lifetime measurements, especially when the measured lifetimes are long. Therefore, the position and width of the entrance slit of the monochromator and the delay times between the ablation and the excitation pulses were adjusted during the experiment in order to identify and eliminate possible influences of such effects. To ensure a linear response of the detection system, the fluorescence signals were detected with different neutral density filters inserted in the exciting laser light path.

The Gd I and Gd II lifetimes reported here fall in the range 2–75 ns. The temporal shape of the excitation pulse thus had to be recorded for the short-lived lifetime measurements. While the ablation laser was turned off, a metal rod was inserted into the interaction zone of the excitation laser and the plasma, and scattered light due to the excitation pulse was collected by the same detection system. The recorded curve is a convolution of the real laser pulse and the time-response function of the detection system. The effects of the finite duration of the excitation pulse and the limited response time of the detection system could be taken into account in the evaluation process by fitting the experimental fluorescence decay curve to a convolution of the detected excitation pulse and a pure exponential function.

Table 1. Levels measured in Gd I and Gd II, with excitation schemes and results.

Configuration	E (cm ⁻¹)	Excitation		Observed	Lifetime (ns)	
		Origin	λ (nm) _{vac}	λ (nm) _{vac}	This work	Previous
Gd I						
4f ⁷ (⁸ S ^o)5d(⁷ D ^o)6s6p(³ D ^o)	26 866.385	215.124	375.22	386.5	59(3)	
	27 041.751	0.0	369.80	372.8	59(3)	59.3(4.2) ^a
	27 118.725	215.124	371.70	371.7	72(4)	77.1(5.4) ^a
4f ⁷ (⁸ S ^o)5d(⁹ D ^o)6s6p(¹ P ^o)	27 315.791	532.977	373.37	373.4	46(2)	43.7(3.1) ^a
	27 135.695	0.0	368.52	371.5	3.5(0.2)	5.4(0.5) ^b
	27 425.245	215.124	367.51	378.4	3.9(0.2)	6.7(0.5) ^b
4f ⁸ (⁷ F)5d(⁸ D)6s	27 704.965	532.977	368.03	368.0	68(5)	
	27 571.672	532.977	369.84	386.8	14.6(0.5)	
4f ⁷ (⁸ S ^o)5d ² (³ F)(¹⁰ F ^o)6p	27 861.093	0.0	358.92	474.5	8.8(0.4)	
	28 111.670	215.124	358.47	463.8	12.2(0.6)	
	28 841.676	999.121	359.16	460.0	10.5(0.6)	
4f ⁷ (⁸ S ^o)5d6s6p	29 451.356	1719.087	360.59	351.5	11.5(0.5)	13.5(0.5) ^b
	30 307.480	215.124	332.31	341.2	24(1)	
	30 394.640	0.0	329.01	438.0	102(5)	
4f ⁷ (⁸ S ^o)5d ² (³ F)(¹⁰ F ^o)6p	30 881.658	532.977	329.50	329.5	7.7(0.4)	
4f ⁸ (⁷ F)5d6s	31 777.972	532.977	320.05	400.1	6.4(0.2)	
4f ⁷ (⁸ S ^o)5d(⁷ D ^o)6s6p(¹ P ^o)	32 133.125	0.0	311.20	407.0	18.5(0.9)	
	32 149.515	0.0	311.05	404.5	7.2(0.4)	
	32 336.079	0.0	309.25	405.2	7.2(0.3)	
4f ⁸ (⁷ F)5d6s	32 384.000	0.0	308.79	458.6	16.6(0.7)	
4f ⁷ (⁸ S ^o)5d ² (³ P)(¹⁰ P ^o)6p	32 785.115	215.124	307.03	387.5	8.5(0.3)	
	33 851.828	1719.087	311.21	304.4	7.6(0.4)	
4f ⁸ (⁷ F)5d6s	35 794.634	532.977	283.59	417.3	9.0(0.4)	
4f ⁷ (⁸ S ^o)5d ² (³ F)(⁸ F ^o)6p	36 191.722	215.124	277.96	337.4	9.7(0.4)	
	36 394.507	532.977	278.85	337.7	9.7(0.5)	
Gd II						
4f ⁷ (⁸ S ^o)5d(⁹ D ^o)6p	25 960.073	0.0	385.21	385.2	6.5(0.2)	
	26 211.912	0.0	381.51	385.4	6.4(0.3)	9.3(1.2) ^b
	26 595.222	0.0	376.01	376.0	6.4(0.2)	14.6(0.5) ^b
	27 162.224	633.273	376.95	376.9	6.1(0.3)	11.7(0.5) ^b
	29 353.344	1158.943	354.68	354.7	5.3(0.2)	
4f ⁷ (⁸ S ^o)6s6p(³ P ^o)	28 502.312	1158.943	365.72	365.7	15.5(0.8)	
4f ⁷ (⁸ S ^o)5d(⁹ D ^o)6p	29 197.887	2856.678	379.63	345.6	12.3(0.6)	
	30 027.378	261.841	335.96	375.9	4.5(0.2)	
4f ⁷ (⁸ S ^o)5d(⁷ D ^o)6p	39 024.491	0.0	256.25	285.7	2.34(0.2)	
	39 170.192	0.0	255.30	279.8	2.34(0.2)	
	39 537.159	3444.235	277.06	320.0	3.12(0.2)	
4f ⁷ (⁸ S ^o)5d(⁷ D ^o)6p	42 628.167	0.0	234.59	307.3	3.01(0.2)	
	42 745.310	0.0	233.94	309.1	2.86(0.2)	

^a Marek and Stahnke (1980).^b Gorshkov *et al* (1983).

Every decay curve was obtained by averaging fluorescence photons from 1000 pulses, in order to obtain a sufficiently high signal-to-noise ratio. For each level measured, about ten fluorescence decay curves were recorded, under different experimental conditions. The averaged lifetime value was adopted as the final result. For the long-lived levels, a least-squares exponential fitting procedure was used to evaluate the lifetimes. For the short-lived

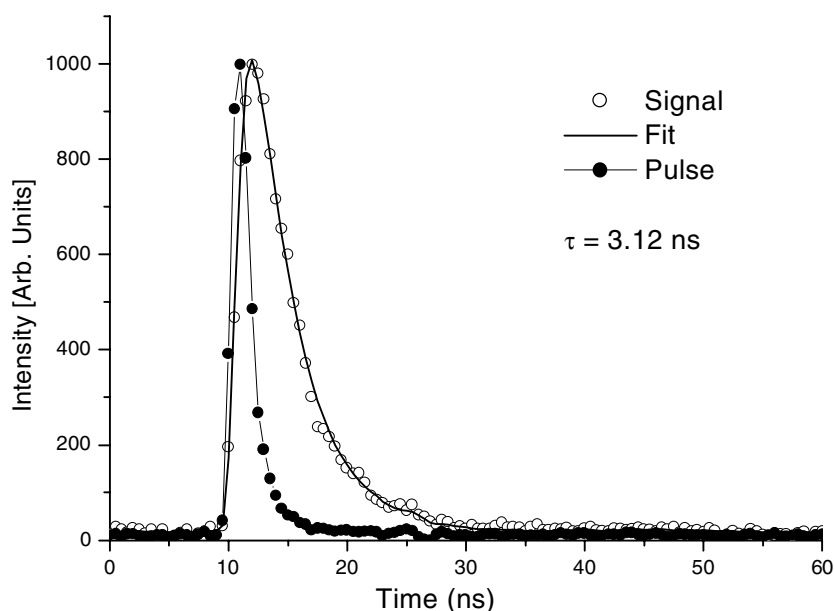

Figure 2. A typical curve for the $39\,537.159\text{ cm}^{-1}$ level of Gd II, with a convolution fit.

levels, a deconvolution fitting procedure was performed, as described above. A typical curve of short lifetime and the corresponding convolution fit are shown in figure 2 for the $4f^75d6p$ ($39\,537.159\text{ cm}^{-1}$) level of Gd II. All experimental lifetime results measured are given in the sixth column of table 1. The error bars of our reported lifetimes reflect not only the statistical errors, but also a conservative estimate for possible remaining systematic errors.

4. Discussion

The lifetime data from the present investigations are compared in table 1 with previously published results. Three levels of Gd I were earlier measured by Marek and Stahnke (1980) using the delayed-coincidence method with laser excitation, and a good agreement with our results, within the quoted uncertainties, was found. However, three lifetimes obtained for Gd I and three for Gd II are much smaller than those reported by Gorshkov *et al* (1983) employing a delayed-coincidence technique with crossing atomic and electron beams (unselective excitation).

In summary, radiative lifetimes of 25 levels for Gd I and 13 levels for Gd II have been obtained using time-resolved LIF techniques, in all of which 29 levels were measured for the first time. These new lifetimes, with a few exceptions, are believed to be accurate to about $\pm 5\%$.

Acknowledgments

This work was financially supported by the Swedish Research Council and by the National Natural Science Foundation of China (no 10274025).

References

- Andrievsky S M, Kovtyukh V V, Luck R E, Lepine J R D, Bersier D, Maciel W J, Barbuy B, Klochkova V G, Panchuk V E and Karpishech R U 2001 *Astron. Astrophys.* **381** 32
- Bengtsson J, Larsson J, Svanberg S and Wahlström C G 1990 *Phys. Rev. A* **41** 233
- Bergström H, Biémont E, Lundberg H and Persson A 1988 *Astron. Astrophys.* **194** 335
- Biémont E, Dutrioux J F, Martin I and Quinet P 1998 *J. Phys. B: At. Mol. Opt. Phys.* **31** 3321
- Gorshkov V N and Komarovshii V A 1986 *Sov. Astron.* **30** 333
- Gorshkov V N, Komarovskii V A, Osheroich A L and Penkin N P 1983 *Opt. Spectrosc. (USSR)* **54** 122
- Li Z S, Norin J, Persson A, Wahlström C G, Svanberg S, Doidge P S and Biémont E 1999 *Phys. Rev. A* **60** 198
- Marek J and Stahnke H J 1980 *Z. Phys. A* **298** 81
- Mathys G and Cowley C R 1992 *Astron. Astrophys.* **253** 199
- Mishin V I and Fedoseev V N 1983 *Opt. Spectrosc. (USSR)* **63** 420
- Miyabe M, Wakaida I and Arisawa T 1997 *Z. Phys. D* **39** 181
- Poli A A, Bord D J and Cowley C R 1987 *Publ. Astron. Soc. Pac.* **99** 623
- Pyper D M 1976 *Astrophys. J. Suppl.* **31** 249
- Rice J B 1978 *Publ. Astron. Soc. Pac.* **89** 770
- Schade W, Wolejko L and Helbig V 1993 *Phys. Rev. A* **47** 2099
- Spector N 1970 *Astrophys. J.* **159** 1091
- Zhang Z G, Persson A, Li Z S, Svanberg S and Jiang Z K 2001 *Eur. Phys. J. D* **13** 301