



# LUND UNIVERSITY

## Service Orchestration with OPC UA in a Graphical Control Language

Theorin, Alfred; Hagsund, Johan; Johnsson, Charlotta

*Published in:*

[Host publication title missing]

*DOI:*

[10.1109/ETFA.2014.7005351](https://doi.org/10.1109/ETFA.2014.7005351)

2014

[Link to publication](#)

*Citation for published version (APA):*

Theorin, A., Hagsund, J., & Johnsson, C. (2014). Service Orchestration with OPC UA in a Graphical Control Language. In [Host publication title missing] IEEE - Institute of Electrical and Electronics Engineers Inc.. <https://doi.org/10.1109/ETFA.2014.7005351>

*Total number of authors:*

3

### General rights

Unless other specific re-use rights are stated the following general rights apply:

Copyright and moral rights for the publications made accessible in the public portal are retained by the authors and/or other copyright owners and it is a condition of accessing publications that users recognise and abide by the legal requirements associated with these rights.

- Users may download and print one copy of any publication from the public portal for the purpose of private study or research.
- You may not further distribute the material or use it for any profit-making activity or commercial gain
- You may freely distribute the URL identifying the publication in the public portal

Read more about Creative commons licenses: <https://creativecommons.org/licenses/>

### Take down policy

If you believe that this document breaches copyright please contact us providing details, and we will remove access to the work immediately and investigate your claim.

LUND UNIVERSITY

PO Box 117  
221 00 Lund  
+46 46-222 00 00

# Service Orchestration with OPC UA in a Graphical Control Language

Alfred Theorin, Johan Hagsund, and Charlotta Johnsson  
Department of Automatic Control, Lund University, Lund, Sweden



## Background

Increasing market demands require highly flexible automation systems. A successful approach to compose flexible software is Service Oriented Architecture (SOA). In this work a convenient way to do SOA service orchestration with OPC Unified Architecture (OPC UA) is presented.

## OPC Unified Architecture

OPC UA offers robust and secure communication for distributed systems. It is backward compatible feature-wise with the classic OPC standards and is platform and language independent. It also offers SOA features and more powerful modeling capabilities with types and instances.

## Me



Alfred Theorin  
Ph.D. student  
alfred.theorin@control.lth.se

## The Grafchart Language

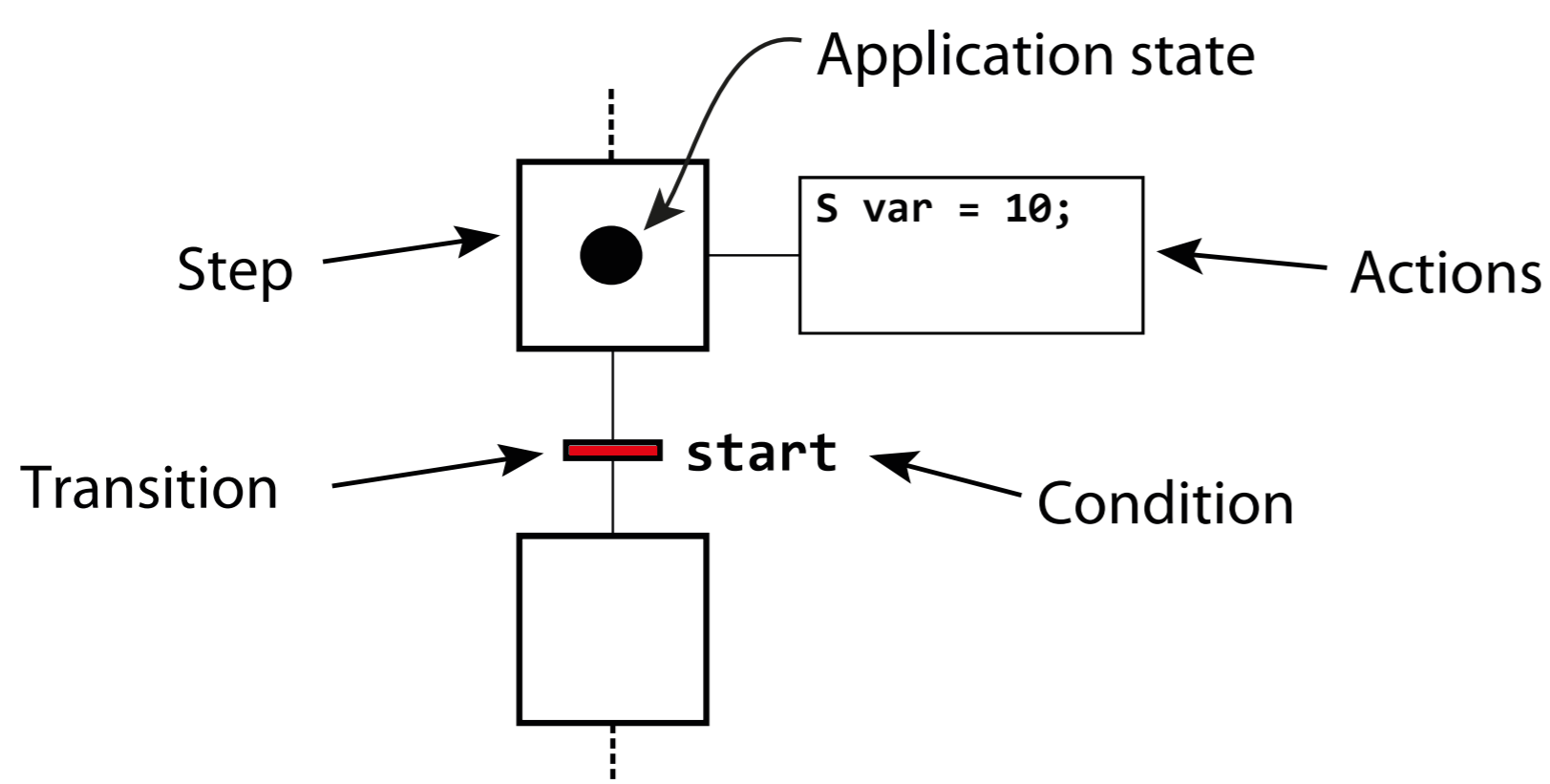

Grafchart is a graphical programming language based on the PLC standard language SFC. The basic building blocks are steps (application states) with actions (what to do when) and transitions (how and when to change application state).

## OPC UA Integration in JGrafchart

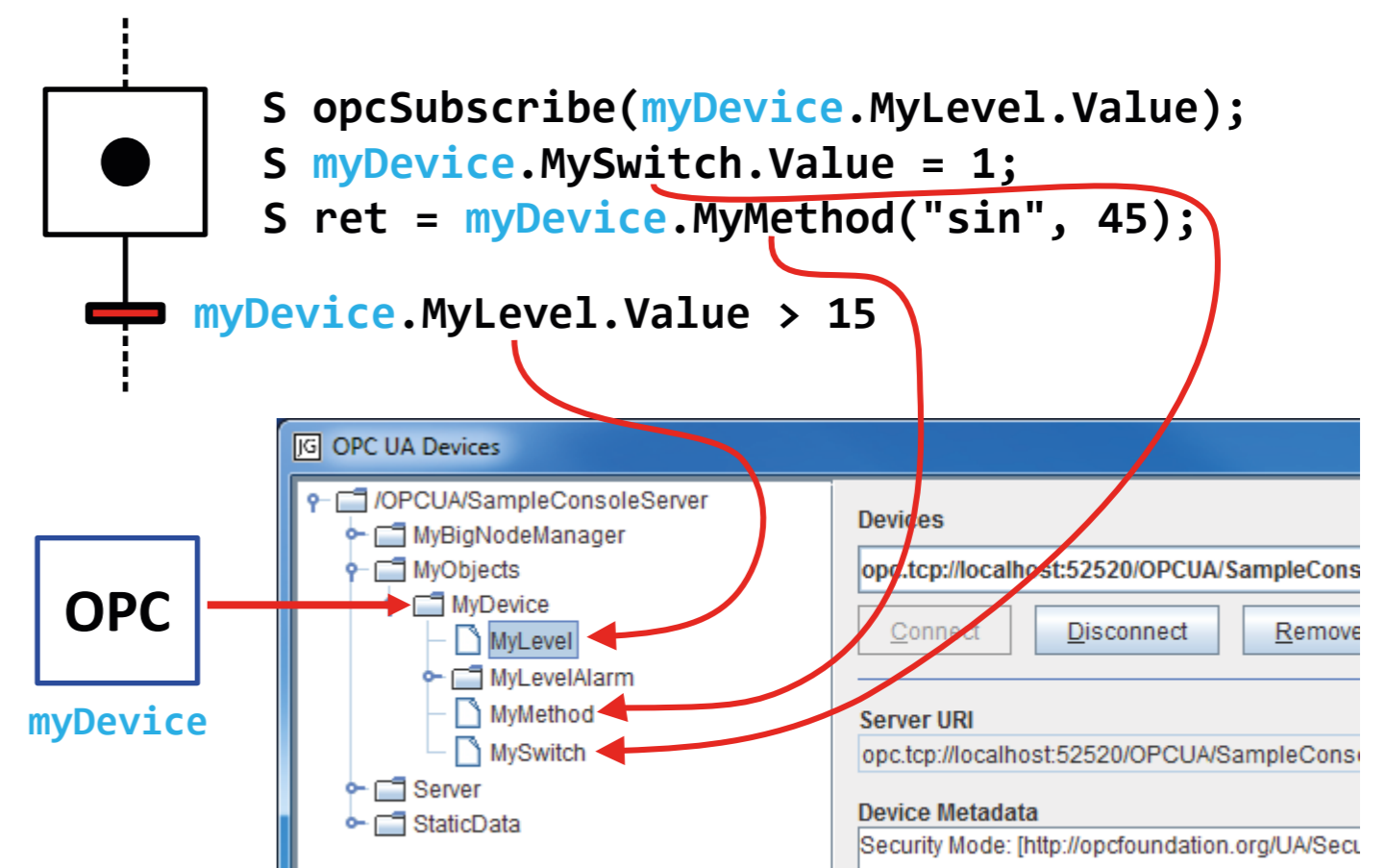

An OPC UA Object is bound to a node in an OPC UA server. The OPC UA variables and methods are then used like native variables and methods.

## Use Case

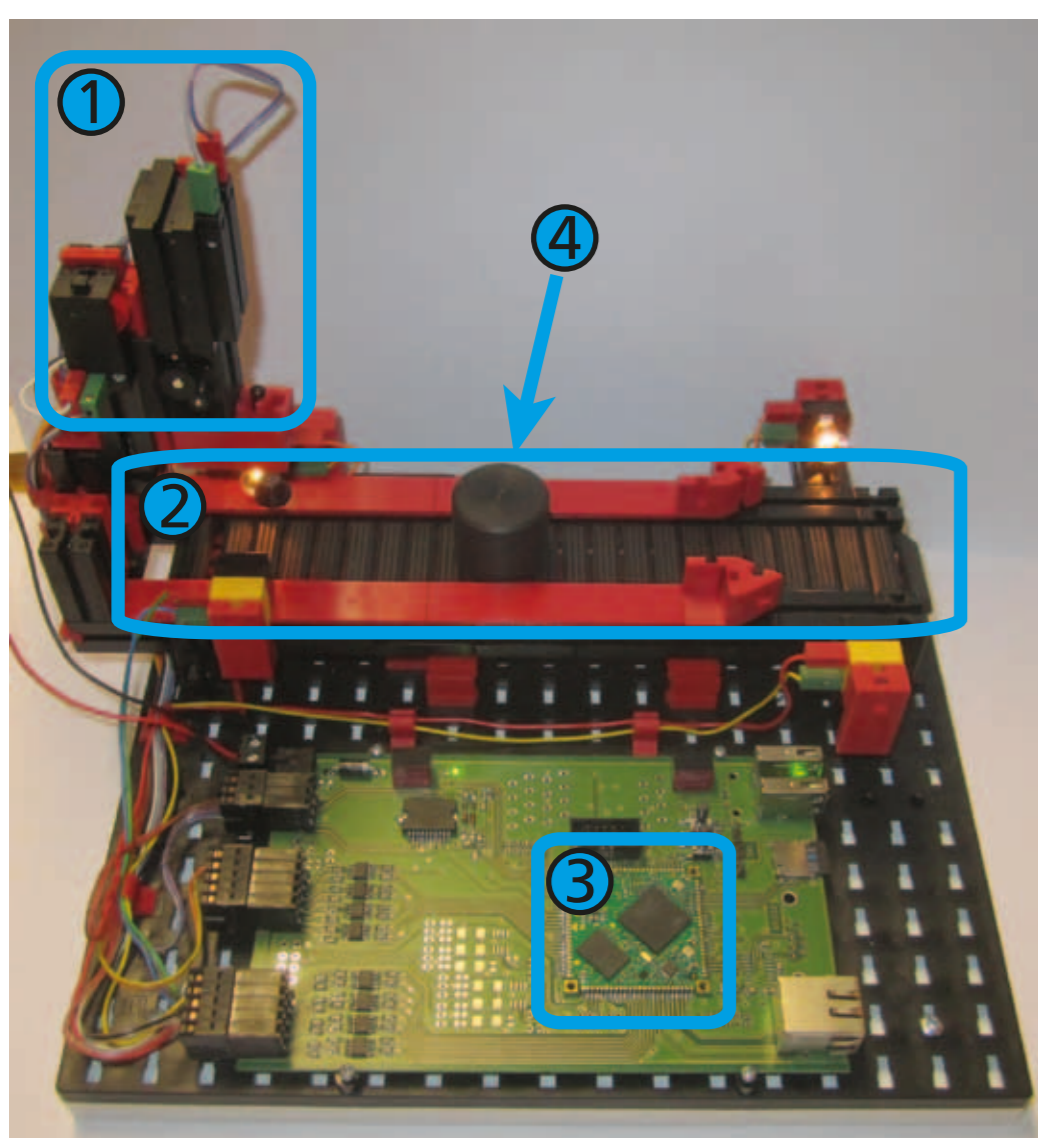

The OPC UA support was tried out on a physical device in an Industry 4.0 setting. The device consists of a punching machine (1) and a conveyor belt (2). A microcontroller (3) was used to expose the device as variables in an OPC UA server.

The task to process incoming goods (4) was straightforward to implement in JGrafchart with the new OPC UA support.

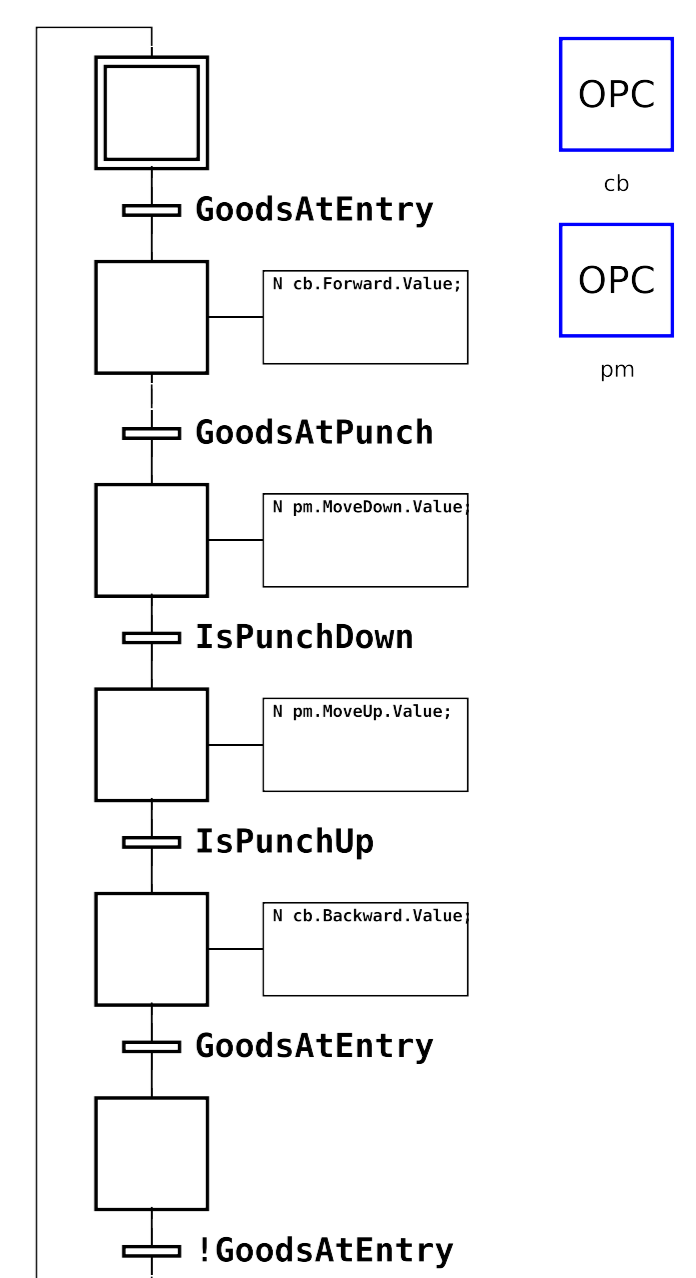
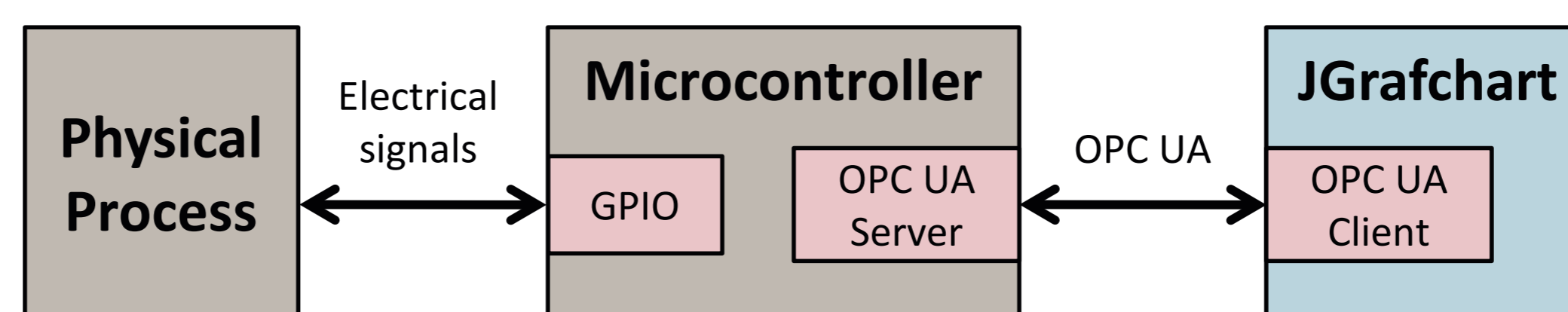

## Conclusions

The new integrated OPC UA support in JGrafchart is a convenient way to do SOA service orchestration in the automation domain. Both DPWS and OPC UA are required to cope with industrial requirements on device level and now JGrafchart supports both. With an OPC classic adapter, JGrafchart can now also interact with most industrial automation systems.

## Acknowledgments

Financial support from the VINNOVA-FFI project LISA is gratefully acknowledged. The authors are members of the LCCC Linnaeus Center and the eLLIIT Excellence Center at Lund University.

