



LUND UNIVERSITY

Using direct manipulation for real-time structural design exploration

Åkesson, Daniel

2016

[Link to publication](#)

Citation for published version (APA):

Åkesson, D. (2016). *Using direct manipulation for real-time structural design exploration*. Lund University (Media-Tryck).

Total number of authors:

1

General rights

Unless other specific re-use rights are stated the following general rights apply:

Copyright and moral rights for the publications made accessible in the public portal are retained by the authors and/or other copyright owners and it is a condition of accessing publications that users recognise and abide by the legal requirements associated with these rights.

- Users may download and print one copy of any publication from the public portal for the purpose of private study or research.
- You may not further distribute the material or use it for any profit-making activity or commercial gain
- You may freely distribute the URL identifying the publication in the public portal

Read more about Creative commons licenses: <https://creativecommons.org/licenses/>

Take down policy

If you believe that this document breaches copyright please contact us providing details, and we will remove access to the work immediately and investigate your claim.

LUND UNIVERSITY

PO Box 117
221 00 Lund
+46 46-222 00 00



LUND
UNIVERSITY

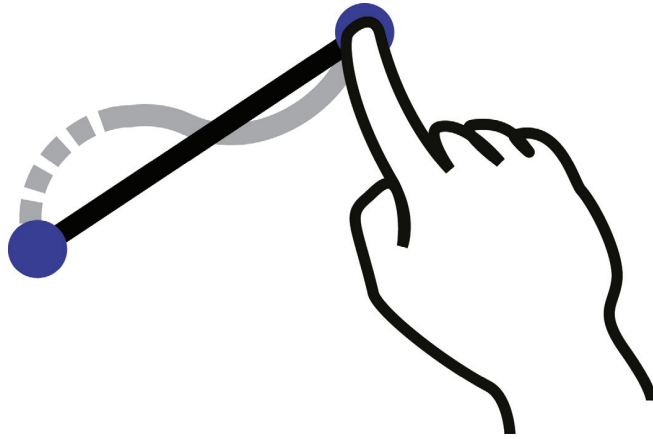

USING DIRECT MANIPULATION FOR REAL-TIME STRUCTURAL DESIGN EXPLORATION

DANIEL ÅKESSON

Structural
Mechanics

Licentiate Dissertation

DEPARTMENT OF CONSTRUCTION SCIENCES
DIVISION OF STRUCTURAL MECHANICS

ISRN LUTVDG/TVSM--16/3076--SE (1-78) | ISSN 0281-6679

ISBN 978-91-7623-834-9 (print) | 978-91-7623-835-6 (Pdf)

LICENTIATE DISSERTATION

USING DIRECT MANIPULATION FOR REAL-TIME STRUCTURAL DESIGN EXPLORATION

DANIEL ÅKESSON

Copyright © 2016 Division of Structural Mechanics,
Faculty of Engineering LTH, Lund University, Sweden.

Printed by Media-Tryck LU, Lund, Sweden, May 2016 (*Pl*).

For information, address:

Div. of Structural Mechanics,
Faculty of Engineering LTH, Lund University, Box 118, SE-221 00 Lund, Sweden.

Homepage: www.byggmek.lth.se

Acknowledgements

The work presented in this thesis was mainly carried at the division of Structural Mechanics at Lund University. The financial support was provided by the Swedish strategic research program eSSSENCE. The support is gratefully acknowledged. I would like to thank Prof. Karl-Gunnar Olsson and Dr. Jonas Lindemann for the initial support and introduction to the research field. Furthermore, I would like to thank Prof. Kent Persson and Prof. Erik Serrano for the feedback on this thesis.

A part of this research was carried out at Massachusetts Institute of Technology. I wish to thank Prof. Caitlin Mueller for making this possible. I am very grateful for the opportunity, and for the inspirational supervision that I received during my stay. Furthermore, I would like to express my gratitude to the other members of the Digital Structures group for offering support and sharing ideas during my stay.

I would furthermore like to thank my colleges at the department of Structural Mechanics, for their good company and for all the interesting discussions. I would in particular like to thank Vedad Alic for all the friendly discussions that we have had while navigating our shared research area.

Finally, a special thanks to Pamela for always being understanding and supportive during the course of this work.

Lund, May 2016
Daniel Åkesson

Abstract

Before a new structure can be built, it must be designed. This design phase is a very important step in the building process. The total cost of the structure and its structural performance are largely dependent on the structural design process. The impact of decisions on the design process is initially high and declines as the design matures. However, few computational tools are available for the conceptual design phase; thus, an opportunity exists to create such tools. In the conventional workflow, the architect uses geometric modeling tools and the engineer uses structural analysis tools in sequential steps. Parametric modeling tools represent an improvement to this workflow, as structural analysis plug-ins are available. This allows the architect or engineer to receive structural feedback at an earlier stage, but still as a sequential step to the geometric modeling. The present work aims to improve this workflow by integrating structural feedback with geometric modeling.

The user interfaces of conceptual design tools should be interactive and agile enough to follow the designer's iterative workflow. Direct manipulation involves human-computer interaction, which enables an interactive user interface. In this user interface style, users can directly manipulate on-screen objects using real-world metaphors, which engages the users with their task and encourages further explorations. This is achieved by reducing the perceptual and cognitive resources required to understand and use the interface. New technologies have opened up the possibility of creating new design tools that make use of very direct manipulation. This possibility is further explored in this thesis through the development of two such applications.

The first application makes use of multi-touch tablets. The multi-touch interface has literally closed the gap between humans and computers, enabling very direct manipulation interactions with two-dimensional user interfaces. The developed application is an interactive conceptual design tool with real-time structural feedback that allows the user to quickly input and modify structural models through the use of gestures. The second application extends these concepts and ideas into a three-dimensional user interface using an input device named the Leap Motion Controller.

Keywords: Interactive structural analysis; Interactive structural form finding; Very direct manipulation

Populärvetenskaplig sammanfattning

Det första skedet när ett byggnadsverk ska uppföras är det konceptuella designskedet, det är här de första besluten om utformningen av byggnadsverket görs. I det traditionella arbetsflödet utformas byggnadsverket först i ett ritprogram, sedan används ett annat datorverktyg för att verifiera att det utformade byggnadsverket kan hantera de krafter som uppstår, t.ex. vind, egentyngd osv. Detta arbete är ett försök till att förbättra detta arbetsflöde genom att skapa nya verktyg som redan i ett konceptuellt designskede ger användaren en återkoppling till hur strukturen kan hantera de krafter som kommer att uppstå så att förbättringar på utformningen kan göras i ett tidigare skede.

För denna typ av verktyg ställs höga krav på användargränssnitt, de behöver vara interaktiva och enkla att arbeta med för att kunna följa designerns iterativa arbetsflöde. Direkt manipulation är en typ av användargränssnitt där användaren direkt kan manipulera objekt på skärmen. Denna typen av användargränssnitt skapar intuitiva gränssnitt som är enkla att förstå och som uppmanar användaren att experimentera och utforska möjligheter. Ny teknik skapar nya möjligheter att skapa nya designverktyg för konceptuell design som använder en sådan, väldigt direkt, gränssnittstil. Dessa nya möjligheter utforskas vidare i denna avhandling genom att utveckla två olika designverktyg.

Det första av dessa verktyg tillåter väldigt direkt manipulation för ett två-dimensionellt (2D) användargränssnitt genom att utnyttja moderna pekskärmar. I det utvecklade verktyget kan användaren enkelt mata in och manipulera modeller genom att använda pekskärmen. Användaren presenteras med resultat från strukturberäkningar i realtid, vilket tillåter användaren att experimentera och utforska nya former. Det andra verktyget som har utvecklats vidareutvecklar dessa koncept och idéer till tre-dimensioner (3D) genom att använda en ny sorts 3D input enhet, som heter Leap Motion.

Resultaten från detta arbetet utgör förslag på hur verktyg för konceptuell design som integrerar strukturella aspekter med hjälp av väldigt direkta användargränssnitt.

Contents

I	Introduction and overview of the work	xi
1	Introduction	1
1.1	The structural design process	1
1.2	Problem statement	2
1.2.1	Examples of well-executed conceptual structural design	4
1.2.2	Computational design tools	5
1.3	Research methodology	6
1.3.1	Aim of research	6
1.3.2	Research questions	7
1.3.3	Research approach and limitations	7
1.3.4	Outline	7
2	Human–computer interaction	9
2.1	Direct manipulation	9
2.2	Visualization	9
2.3	Technology	10
3	Computational methods	13
3.1	Structural form-finding	13
3.1.1	Dynamic relaxation	13
3.2	Optimization methods	15
3.2.1	Gradient-based methods	16
3.2.2	Evolutionary algorithms	16
3.2.3	Topological optimization	18
3.3	Eigenvalue analysis	18
3.4	Graphic statics	18
4	Literature review	21
4.1	Analysis-based tools for engineers	21
4.2	Geometry-based tools for architects	21
4.2.1	History	21
4.2.2	Present day	23
4.3	Existing conceptual design tools	24
4.3.1	Real-time analysis tools	24
4.3.2	Graphic statics tools	25
4.3.3	Interactive optimization design tools	26

4.3.4	Topological optimization design tools	26
5	Integrating structural feedback in conceptual design tools	29
5.1	Human–computer interaction	29
5.2	Structural feedback	30
5.3	Structural optimization	31
5.4	Visual representations	32
5.4.1	Example - Stress lines	33
6	Summary of appended papers	35
6.1	Paper A	35
6.2	Paper B	36
7	Results & discussion	37
7.1	Summary of intellectual contributions	38
7.2	Future work	38
	References	39
II	Appended publications	39

Paper A

A tablet computer application for conceptual design

Daniel Åkesson, Jonas Lindemann

Accepted for publication in Engineering and Computational Mechanics, 2015

Paper B

Using 3D direct manipulation for real-time structural design exploration

Daniel Åkesson, Caitlin Mueller

Submitted

Part I

Introduction and overview of the work

1 Introduction

1.1 THE STRUCTURAL DESIGN PROCESS

Before a new structure can be built, it must be designed. This design phase, here termed the *structural design phase*, is a very important step in the building process. The total cost of the structure and its energy performance and structural performance are largely dependent on the structural design process [?].

The structural design process is rarely straightforward. Rather, solutions are reached through an iterative and often chaotic process. This process can be divided into the following four steps [?]:

1. **Conception:** The most important design step, where the overall design concept and significant details are developed.
2. **Modeling:** Idealization and simplification of the structural design concept, building of models for structural analysis, and calculation of forces.
3. **Dimensioning:** Determining sectional dimensions of structural members depending on the choice of materials.
4. **Detailing:** Final details of nodes and connections, including the creation of construction documents.

In reality, there is no clear distinction between the different design steps, and the process can iteratively move back and forth until a solution is reached. In this thesis, the term “conceptual design” refers to the first design step of conception and the initial phase of the modeling step. In the initial design phase, there is considerable design freedom. At the same time, the impact on the final result of the decisions taken at this early stage is often crucial. In contrast, both the design knowledge and the availability of design tools increases as the design matures [?] [?]; see Figures 1.1 and 1.2. The design knowledge comprises all that is known of the final design, from the color of the facade to the dimensions of structural members. The lack of tools for the initial design phase, combined with the high impact of decisions, creates the opportunity

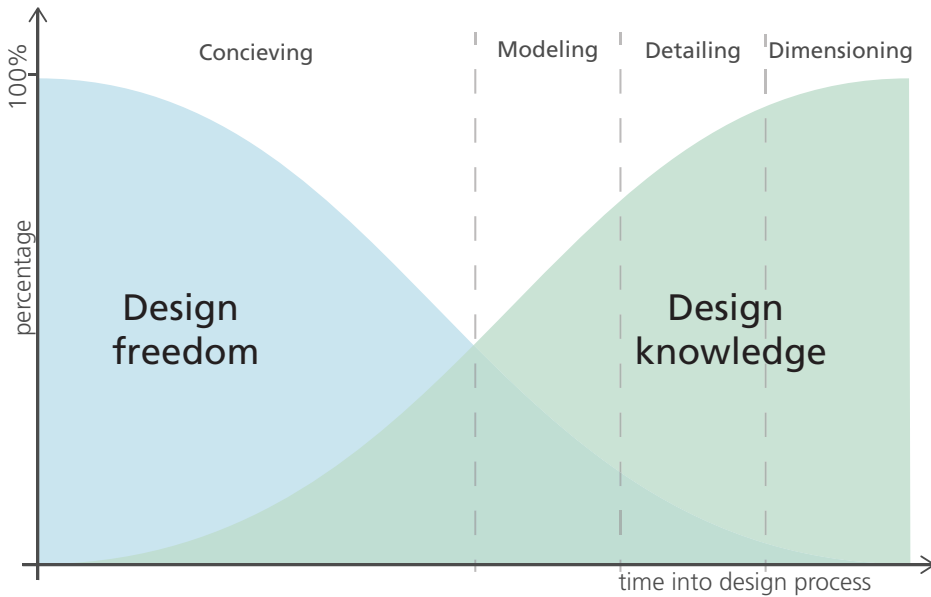

Figure 1.1: Structural design process [?]

to develop tools that support designers in making well-informed decisions in the conceptual design phase.

1.2 PROBLEM STATEMENT

Many different geometric modeling tools are currently available to architects. These geometric modeling tools have, since their introduction in the 1980s, grown increasingly sophisticated. They have also, together with the widespread perception of the benefits of technological innovation, created a more intimate relationship between technology and design. This relationship has resulted in parametric design and scripting methods that can generate complex shapes and forms [?]. The distinct separation found in practice, whereby architects use geometric modeling tools and engineers use analysis tools, further reinforces the roles of the architect as *form-giver* and the engineer as *form-verifier* [?]. To move away from this separation, this thesis uses the term *designer* to represent either an engineer or an architect. Instead of the current practice, it would be beneficial if engineers and architects collaborated as designers in the structural design process. This would allow physical demands (e.g., structural performance, construction costs, operational energy needs, acoustics) to work as an inspiration, rather than as a constraint on what is possible, in finding new, high-performing geometric forms. In the current practice, the architect often conceives a design without any involvement from the structural engineer. Hence, the importance of the conceptual design phase is often overlooked, and structural aspects are sometimes only considered in the later design stage [?]. A contributing factor to this is that very few computational tools are available for conceptual design.

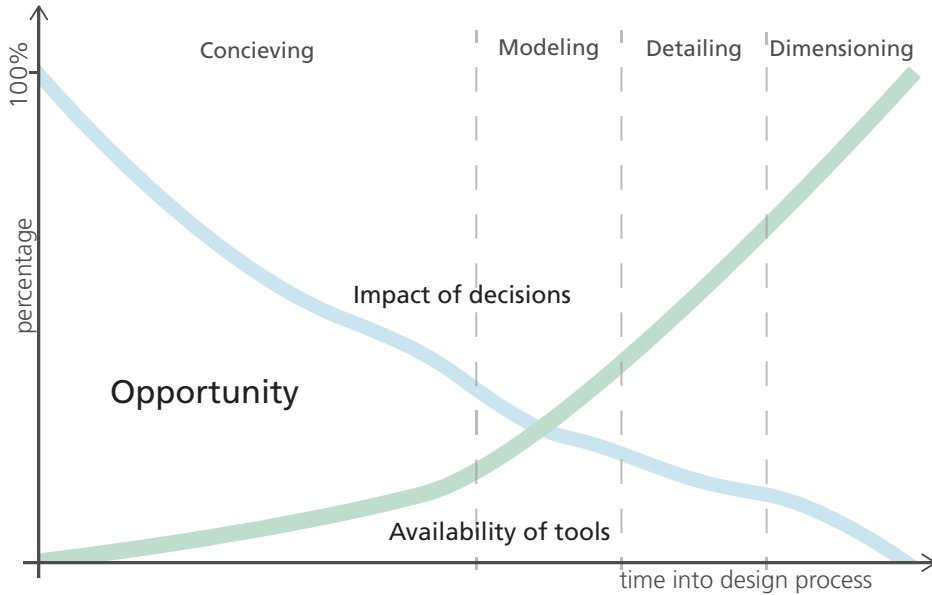

Figure 1.2: Impact of decisions and availability of tools in the design process [?]

In developing such computational tools, the challenge lies within the fuzzy nature of the problem, as the knowledge and constraints of the problem are often imprecise and incomplete [?].

Conventional advanced structural analysis software requires precise knowledge of the problem, and is insufficiently agile to follow a designer's iterative workflow. Conventional structural analysis software has been developed for use in the late design stage, after the major design decisions have been made, for the engineer to verify the form.

A subsequent problem with the traditional workflow in which the architect is the form-giver and the engineer is the form-verifier arises from the availability of a very detailed geometric model. It can be tempting for the engineer to directly perform a full analysis on the detailed geometry, something that is possible with current structural analysis software. Instead, if the engineer starts with a simple mathematical model and then gradually increases the complexity (known as hierarchical modeling, see Figure 1.3), the risk of fatal mistakes decreases [?].

By starting with a simple mathematical model, the engineer can focus on, and gain a better understanding of, the overall structural behavior, such as how stresses propagate through the structure, the magnitude of the stresses in different structural members, and so on. This information is valuable in confirming the feasibility of the results given by more advanced mathematical models. It has been shown that the premature use of advanced structural analysis software has a negative effect on the conceptual understanding and quality of the design [?].

In the present work, two similar conceptual design tools have been developed. The two applications make use of simple mathematical models, thus enabling structural modeling to be used earlier in the structural design process. The motivation for this is two-fold. First, it provides

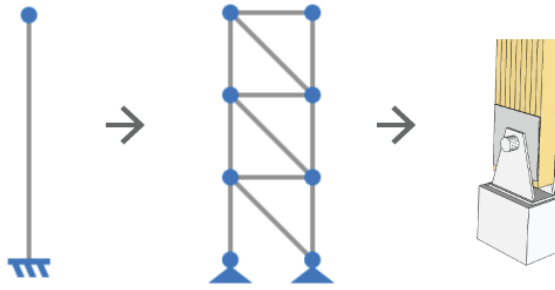

Figure 1.3: Hierarchical modeling

designers with valuable feedback on structural performance in the conception phase, when the impact of decisions is high. Second, it presents engineers with valuable feedback on structural behavior before a more advanced model is used.

The type of design tool used to generate and represent ideas also affects the quality and quantity of early prototypes. It has been shown [?] that physical prototyping generates a higher quantity of prototypes per unit time than using CAD or conventional sketching. The prototypes developed using physical prototyping were also perceived to be more novel than the other prototypes. However, the prototypes that were perceived as more novel also tended to fare poorly on all other measurable qualities [?].

In the present work, the prototypes are structural models. As computational models are used, measurable performance indices can be computed and presented to users in real time. This has the potential to improve the quality of the structural models. The measurable performance and guidance in the present work focuses on the geometrical form of the structure, as this has the greatest potential to improve the structural performance [?].

1.2.1 Examples of well-executed conceptual structural design

As mentioned earlier, structural demands can be integrated earlier in the design process by using them as the inspiration for geometric forms, instead of constraints on what is possible. Integrating structural demands earlier in the design process has, amongst other, the potential to reduce the amount of material needed, thus reducing the environmental impact and costs of the project as a whole.

Good examples of well-executed conceptual designs include the structures designed by the Italian architect-engineer Pierre Luigi Nervi (see example in Figure 1.4). Despite the complexity of the structures, his designs were often selected because they required less material than those of his competitors, and were therefore the cheapest to build [?]. This type of complex concrete structure is unfeasible when labor costs are high, because of the extensive formwork required [?]. However, this could of course change in the future with the emergence of robots



Figure 1.4: Pierre Luigi Nervi - Air hangar, built 1936

and digital manufacturing [?].

“His buildings are most remarkable for the clarity of their engineering. The power and grace of these extraordinary shapes and patterns stems directly from their structural logic, and are inseparable from it” – Ada Louise, talking about Pierre Luigi Nervi, 1960 [?]

The Shenzhen CITIC Financial Center (see Figure 1.5) is a more recent example of well-executed integrated conceptual design. The perimeter frames are inspired by research on optimal discrete truss geometries to minimize the material needed [?].

Designing Nervi’s air hangar in 1936 required a very thorough understanding of structural mechanics. At the time, Nervi was one of very few engineers that were capable of successfully designing such a structure. The CITIC Financial Center was also designed by a team of distinguished designers. The difference between the two examples is that the latter used computer simulations in the design process.

1.2.2 Computational design tools

Computational design tools have the ability to make computer simulations readily available in the design process, thus helping to guide the designer towards solutions that perform well. Various tools have been developed for this purpose, and a review of existing tools and the methods that they implement is given in 3. Unlike conventional structural analysis software,



Figure 1.5: Shenzhen CITIC Financial Center, Lead Architectural Partner: Craig W. Hartman, Lead Structural Partner: Mark Sarkisian. Rendering © Skidmore, Owings & Merrill LLP, 2016

these tools were developed to follow the designer's iterative workflow.

Allowing these computational tools to follow the designer's iterative workflow places high demands on their user interfaces. Most existing computational design tools were developed for mouse and keyboard input. In the present study, alternative input devices that allow for more direct input are explored.

1.3 RESEARCH METHODOLOGY

1.3.1 Aim of research

The long-term goal of this research is to improve the conceptual design phase by integrating structural demands early in the design process. An improved conceptual design phase has the potential to improve certain qualities of structures in the built environment. These qualities include the structural performance, construction costs, operational energy needs, and acoustics.

The specific aims of the present work are:

- To create intuitive conceptual structural design tools that allow users to easily explore different design alternatives.
- To improve the human–computer interaction for such tools through the use of new, novel user input devices.

1.3.2 Research questions

- How can human–computer interaction be improved in conceptual structural design tools?
- Which computational methods can be used to improve the conceptual design phase?

1.3.3 Research approach and limitations

The present research is a multi-disciplinary study involving structural mechanics, computer science, and architecture. Methods from structural mechanics are used to provide the user with guidance and feedback. The development of user interfaces and use of programming techniques is an area of computer science, and studying conceptual design and finding geometrical forms is a branch of architecture. Any successful tools developed in this research could potentially be used in practice.

Different research approaches can be used to investigate how to improve the conceptual structural design phase. This study only investigates how new computational tools can enhance the conceptual design phase. Project management, social aspects, and culture are not considered in this work.

Many different computational methods have been used for conceptual structural design. Some promising methods are discussed in Chapter 3, and a selection of these methods are used in the present work.

1.3.4 Outline

Part I gives an introduction to the research area and reviews the literature in this field. This part is similar to, but an extension of, the introductory sections in the appended papers. **Chapter 1** provides an introduction to the research area, and explains the motivation and importance of this work. **Chapter 2** introduces the concept of human–computer interaction and describes state-of-the-art technologies such as new input devices. **Chapter 3** presents computational methods that can be applied to conceptual design. Different optimization methods, particularly genetic algorithms, are discussed, as these methods will be used in future work. **Chapter**

4 reviews existing conceptual structural design tools. In **Chapter 5**, the requirements for integrating structural feedback in the conceptual design are presented, and the present work is summarized. The publications that have resulted from this work are listed in **Chapter 6**, and **Chapter 7** summarizes the intellectual contributions of this study. **Part II** contains the appended publications.

2 Human–computer interaction

Human–computer interaction is a multi-disciplinary research area that covers user interface design, hardware, software, social aspects, and more. Usability and user experience is of fundamental importance in this research area.

With new technologies such as novel input devices and increased computational power come new possibilities. The present work makes use of these possibilities, using novel user input devices for structural modeling and increased computational power for real-time structural analysis.

2.1 DIRECT MANIPULATION

Direct manipulation is a human–computer interaction style characterized by the continuous representation of objects of interest with rapid, reversible, and incremental feedback [?]. Users can directly manipulate objects on the screen using real-world metaphors, which engages the users with their task and encourages further explorations [?]. This is achieved by reducing the perceptual and cognitive resources required to understand and use the interface [?].

2.2 VISUALIZATION

Scientific visualization is a subfield of computer graphics. The purpose of scientific visualization is to graphically illustrate scientific data. This is also important in conceptual structural design software, as visualizing the design result is of great importance. The visualization should be such that the user can quickly interpret the result and gain insight from it.

Figure 2.1 shows an example of how the results of computational analysis can be visualized. The original geometry of an undeformed car is modified with the computed displacements. The geometry, in this case the car, can be colored according to some selected condition, e.g., von Mises stress, shear force, bending moment.

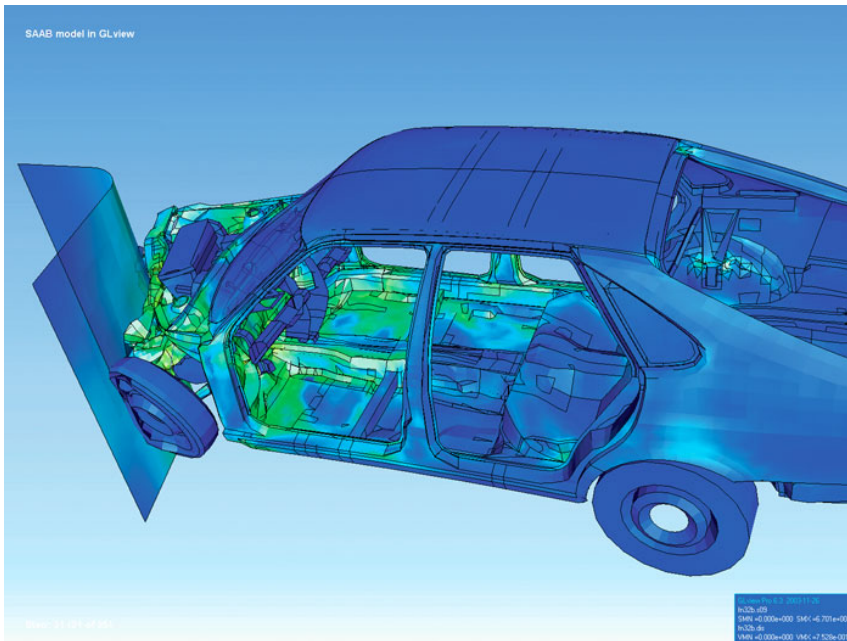

Figure 2.1: Visualization of how a car deforms in an asymmetrical crash using finite element analysis [?].

Edward Tufte is a pioneer in the field of data visualization [?, ?, ?]. His principles of graphical excellence can be stated as follows [?]:

- Graphical excellence is the well-designed presentation of interesting data—a matter of substance, of statistics and design.
- Graphical excellence consists of complex ideas communicated with clarity, precision and efficiency.
- Graphical excellence is that which gives to the viewer the greatest number of ideas in the shortest time with the least ink in the smallest space.

2.3 TECHNOLOGY

The introduction of input devices such as the mouse and joystick significantly improved human–computer interaction with interfaces that adapted accordingly [?]. When the touch screen was introduced, it had a vital advantage over all these devices—the user could literally touch objects on the screen to manipulate them, creating a very direct method of inputting information [?]. This closed the gap between the human and the computer.

There is a wide variety of interaction techniques that create direct manipulation interfaces for three-dimensional (3D) applications using two-dimensional (2D) input devices such as the mouse [?]. However, as such input devices have one degree of freedom less than the 3D user interface, there will always exist a need for some form of gestures.

The Leap Motion Controller [?] is a relatively small and simple input device that is placed in front of the keyboard. The controller then tracks the user's hands across the controller's field of vision. Combined with a software development kit (SDK), the controller creates a computational model of the user's hands, which can then be used to interact with software in three dimensions. This enables very direct manipulations for 3D user interfaces.

Computer games have led the development of novel input devices along with new styles of games to address some limitations of conventional systems [?], e.g., the Wii remote [?], Microsoft's Kinect for Xbox [?], and the PlayStation Move [?]. These novel input devices have moved away from the conventional human-computer interaction to invoke an intuitive interface that supports the natural human approach to interaction. For a long time, games have been perceived as fun and engaging, and many different research disciplines have investigated whether gaming methods can be used to improve human-computer interactions to create more effective, immersive, and engaging forms of learning or training [?].

Interest in the development of virtual reality glasses has recently increased as products such as the Oculus Rift [?] and PlayStation's Project Morpheus [?] have become widely available. These virtual reality glasses have primarily been developed for games, but have received interest from other fields, e.g., to help students understand complex structural behavior [?].

3 Computational methods

In this section, a number of computational methods that can be used for conceptual structural design are introduced.

3.1 STRUCTURAL FORM-FINDING

Physical models or numerical simulations can be used for form-finding, which aims to find the form of a structure under load where some static equilibrium is satisfied. The static equilibrium corresponds to a structure that can support the applied load efficiently. For physical models, a hanging chain or cloth can be used to find the static equilibrium.

The different form-finding methods can be divided into three major categories [?]:

- Stiffness matrix methods based on elastic and geometric stiffness matrices. These methods have been adapted to structural analysis for form-finding.
- Geometric stiffness methods. These material-independent methods include the force density method [?], which uses the ratio of force to length. Several other methods have been developed by extending this approach.
- Dynamic equilibrium methods. These methods find the steady-state equilibrium through use of dynamical modeling. One such method is dynamic relaxation [?], which is explained in further detail in Section 3.1.1.

3.1.1 Dynamic relaxation

Dynamic relaxation involves solving a set of nonlinear equations. The method computes the movement of a structure over time to find the static equilibrium between the internal and external forces [?,?].



Figure 3.1: Example of form-found structures. Left: Concrete dome by Heinz Isler, © Chriusha, Wikimedia Commons; Right: Multihalle in Mannheim by Frei Otto © Hubert Berberich, Wikimedia Commons

In each time step Δt , the internal forces f_{int} , for all elements are computed from the nodal displacements u . A residual R can be computed as

$$R = f_{ext} - f_{int}$$

where f_{ext} represents the external forces acting on the structure. Using Newton's second law, the acceleration (time derivative of the velocity) can be computed for node i in the x -direction at time t as

$$R_{ix}^t = M_i \cdot \dot{v}_{ix}^t$$

where M_i is a lumped, fictitious mass at node i . To enforce suitable boundary conditions, the residual is set to zero for the corresponding degrees of freedom. With the time step known, the velocity of node i in the x -direction can be computed using a finite difference method:

$$v_{ix}^{t+\Delta t} = v_{ix}^{t-\Delta t} + \frac{\Delta t}{M_i} \cdot R_{ix}^t$$

With this velocity, the updated geometry can be determined as

$$x_{ix}^{t+\Delta t} = x_i^t + \Delta t \cdot v_{ix}^{t-\Delta t/2}$$

Once the geometry has been updated, this iteration is complete and the computations start over by computing the new residual. The geometry is modified in each iteration until an equilibrium is reached between the external and internal forces. Viscous or kinetic damping is often used to aid convergence [?].

A formulation that combines CAD-geometry and dynamic relaxation [?] for form-finding has recently been developed.

3.2 OPTIMIZATION METHODS

Michell pioneered the field of structural optimization, and in 1904 published a series of results using minimum-weight Michell trusses [?]. These trusses are still used today as benchmarks for topological optimization of framed trusses [?].

Structural optimization is a numerical method that finds the best solution for a mathematically formulated objective function subject to a set of constraints. The following function and variables are always present in structural optimization [?]:

- *Objective function* (f) - A function that classifies designs with respect to a quantifiable objective. This function returns a numerical value that represents the quality of the design regarding one or more criteria. Usually, a smaller function value is better, i.e., a minimization problem. Frequently, f measures the weight, maximum displacement, strain energy, or cost of a design.
- *Design variable* (x) - A vector that describes the design with numerical values, the design variable often represents the topology, nodal positions, cross-sectional area, or material.
- *State variable* (y) - For a given design with the design vector x , the state variable y represents the response of the structure, i.e., how well the structure performs in terms of the evaluated criterion.

The optimization problem can with the function and variables above be described as follows [?]:

$$SO = \begin{cases} \text{minimize } f(x, y) \text{ with respect to } x \text{ and } y \\ \text{subject to } \begin{cases} \text{behavioral constraints on } y \\ \text{design constraints on } x \\ \text{equilibrium constraints} \end{cases} \end{cases} \quad (3.1)$$

Various optimization methods have been developed, and the best method for any one problem will depend on the associated solution space. A problem can also have multiple objective functions, i.e., multi-objective optimization, which can be formulated as follows:

$$\text{minimize}(f_1(x, y), f_2(x, y), \dots, f_n(x, y))$$

This is not a standard optimization problem, as the objective functions are optimized for the same design variables. Instead, a so-called Pareto optimality is sought, where there is no other

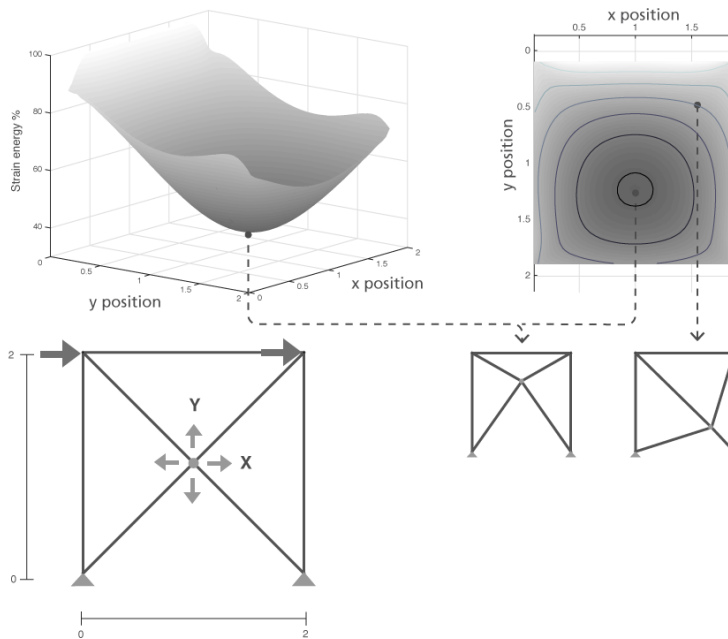

Figure 3.2: Design space for a shape optimization problem

design that better satisfies all the objectives [?]. If no single Pareto optimal point exists, a Pareto front can be found in some objective space that has different objectives on the axes, e.g., structural efficiency, operational energy consumption, sunlight.

3.2.1 Gradient-based methods

Gradient-based methods make use of the first and/or second derivative of the objective function to iteratively converge towards a solution. These methods are fast, consistent, and their results are repeatable (no randomness). However, the solution space of the objective function must be convex (such as the design space in Figure 3.2), continuous, and at least once-differentiable. The problem with using such methods for engineering and design is that many of the scenarios are messy [?] in that they have non-convex solution spaces that contain multiple local optima. Examples of gradient-based techniques include steepest descent and the Newton–Raphson method [?].

3.2.2 Evolutionary algorithms

Evolutionary algorithms are a collection of generic population-based heuristic optimization algorithms [?]. These algorithms are inspired by biological evolution, survival of the fittest,

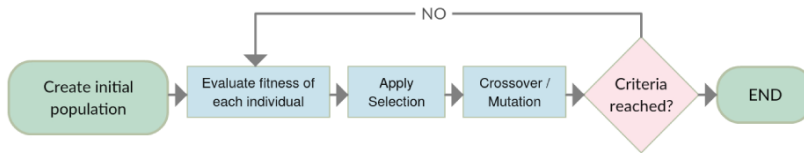

Figure 3.3: Genetic Algorithm procedure

and natural selection. The solvers introduce a degree of randomness to search the solution space, which improves the ability to find global optima.

One of the best-known and most widely used algorithms in this category is the genetic algorithm [?], which is inspired by biological evolution. This algorithm has the benefits of being robust, guaranteeing a solution, and not requiring a differentiable objective function.

The genetic algorithm can be described as follows (see Figure 3.3):

1. *Create initial population* – First, an initial population is created, either at random or through some type of sampling (e.g., Latin hypercube sampling [?]).
2. *Evaluate fitness of each individual* – The objective function is evaluated to assign a score (heuristic) to each individual.
3. *Apply selection* – Individuals with higher fitness scores have a better chance of being selected for crossover, a metaphor for mating.
4. *Crossover/Mutation* – The individuals with higher fitness scores recombine their properties (in this context, design variables) with each other to create a new generation. Introducing a small chance of mutation, or random change, when two individuals crossover reduces the risk of the algorithm becoming trapped around a local optima. Elitism can be introduced to allow the best performing individuals to move to the next generation, which can improve convergence.
5. *End* – The procedure continues until a preselected criterion is reached, often the maximum number of generations or when the solution has converged.

One weakness of the genetic algorithm is that it can be computationally expensive, as the objective function must be called for each new individual. There is also a lot of fine tuning involved with the different types and rates of crossovers, mutations, and other parameters.

Genetic algorithms have the benefit that multiple strong solutions can be presented to the user (different individuals from the population). This can be used in conceptual design, where an aesthetically attractive, well-performing solution is sought. The algorithm can also be used for interactive optimization [?], whereby a user can intervene in the selection process to move the population in the desired direction. Genetic algorithms have also been extended to multi-objective optimization, where the population converges to the Pareto front [?].

3.2.3 Topological optimization

To optimize the material layout for a given a set of boundary conditions and external forces, topological optimization can be used. This method can be implemented through the use of finite element analysis combined with optimization methods [?]. However, the resulting optimal material layout can be highly complex, making it infeasible to actually build.

3.3 EIGENVALUE ANALYSIS

Eigenvalue analysis can be used to find the dynamic or static modal shapes of a structural model. From the stiffness matrix \mathbf{K} of a structure, a set of scalar stiffness values can be determined [?]. Assume that the set of displacements \mathbf{a} is proportional to a corresponding set of forces \mathbf{f} , i.e.,

$$\mathbf{f} = \lambda \mathbf{a}$$

This can be combined with a linear elastic finite element formulation, i.e.,

$$\mathbf{K}\mathbf{a} = \mathbf{f} = \lambda \mathbf{a}$$

which can be rewritten as

$$(\mathbf{K} - \lambda \mathbf{I})\mathbf{a} = 0$$

This is a standard eigenproblem. The eigenvalues λ correspond to the unit force/length, also called the canonical stiffness value [?]. Every eigenvalue λ_i has a corresponding eigenvector \mathbf{a}_i that describes a modal shape. Eigenvalues equal to zero indicate that zero energy is required to form the corresponding modal shape, i.e., a rigid body motion. The eigenvectors are only defined to within a scalar multiple. To create an animation of the modal shape, the eigenvector can be normalized and multiplied by positive and negative scalars. This results in two different shapes, which can be interpolated to create an animation.

3.4 GRAPHIC STATICS

Graphic statics is a graphical method that can be used for structural form finding and for computing forces for structural models using a force diagram. The method was first described in 1866 by Karl Culmann [?], and was widely used until the 1970s, when the increase in computational power made numerical simulations more readily available.

This method has recently gained attention from the research community [?, ?, ?] because of its simplicity and power. However, the use of graphic statics is limited to problems with axially loaded members.

4 Literature review

4.1 ANALYSIS-BASED TOOLS FOR ENGINEERS

The development of finite element analysis (FEA) has resulted in many different, but very similar, software analysis tools. These tools are often too complex and not agile enough to be used for conceptual design. Their use requires a high level of skill, both in connection with the software and in engineering terms. This type of software has been developed for the late design stage, as a tool with which engineers can verify the form.

The analysis procedure for this type of software is often a step-by-step workflow, where all the steps need to be completed in order before the analysis is carried out (see Figure 4.1). The user experience has been compromised by this step-by-step evolution.

4.2 GEOMETRY-BASED TOOLS FOR ARCHITECTS

4.2.1 History

The first computer-aided design (CAD) tool, Sketchpad [?], was developed by Ivan Sutherland at MIT in 1963. The revolutionary feature of Sketchpad was a real-time representation of the geometry on the display. The geometry could be modified with the use of a new input device, a light pen. The light pen enabled a complete interaction loop between the computer and the designer. The software supported complex relationships between graphical elements; for example, a line could be defined by its relationship to other graphical objects, i.e., perpendicular to, parallel to, same length, etc. Sutherland envisioned that designers would first create a

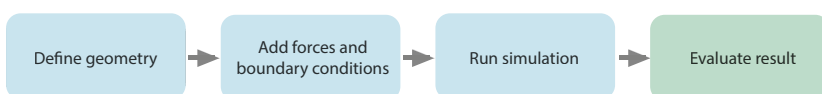

Figure 4.1: Conventional simulation cycle

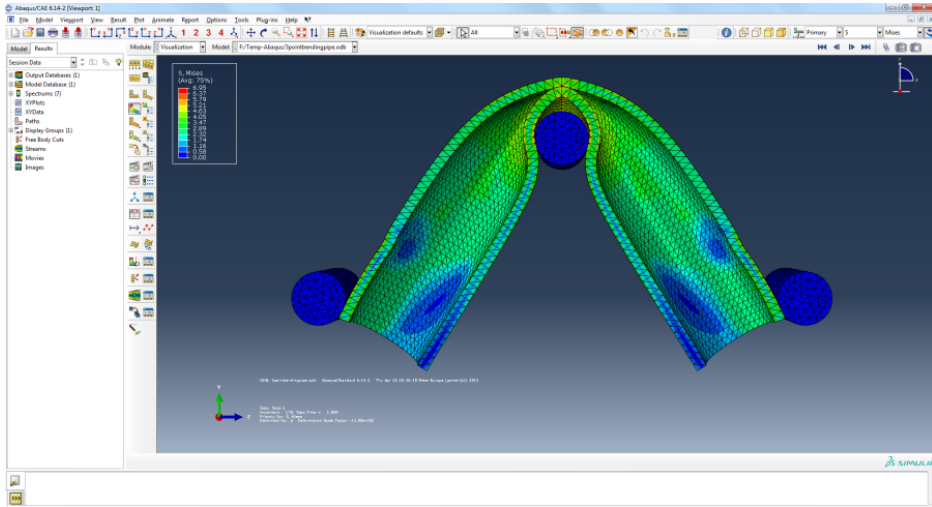

Figure 4.2: User interface of conventional analysis software (ABAQUS)



Figure 4.3: Sketchpad - the first CAD tool

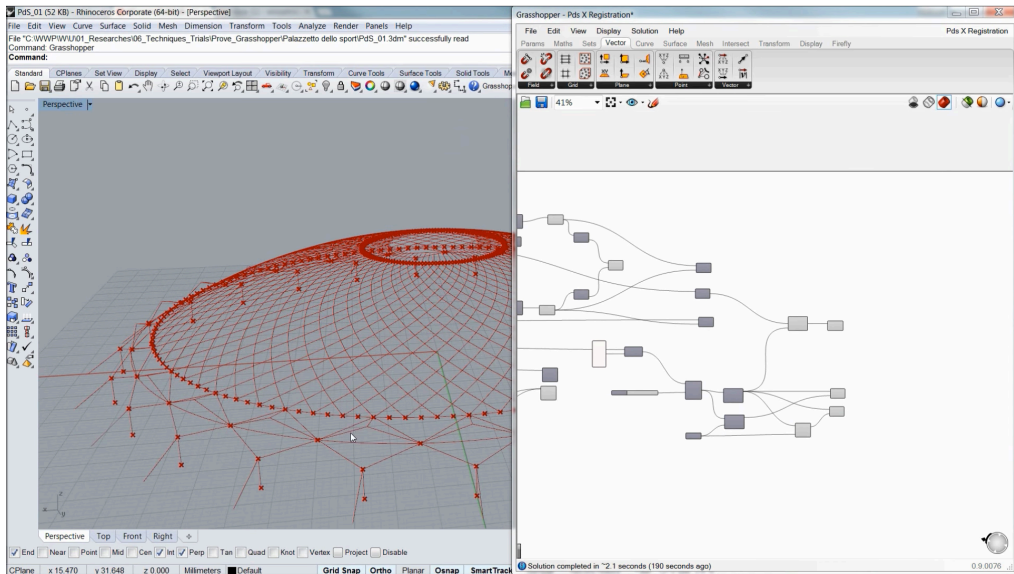

Figure 4.4: Parametric model, in Rhinoceros 3D with Grasshopper, of the thin-shell concrete dome “Palazzetto dello Sport” by Annibale Vitellozzi and Pier Luigi Nervi

rough sketch of the design, and then, as the design matured, apply constraints to the graphical objects to obtain a more detailed and precise design.

CAD tools, in the form of 2D drafting tools, first became widely affordable and accessible in the 1980s [?]. Unfortunately, the subsequent 2D drafting software failed to capture Sutherland’s original intention of using the computer as a creative design tool, as it did not include a constraint model.

4.2.2 Present day

Many different geometric modeling tools are currently available to designers. For instance, parametric modelers have successfully captured some of Sutherland’s ideas in terms of constraint models. The Rhinoceros 3D software [?], which is a NURBS modeler, can be combined with the Grasshopper plug-in [?] to enable a visual programming environment, see Figure 4.4. The software developer Autodesk has also launched a parametric modeling tool named Dynamo [?] that has similar features.

In Grasshopper, the designer can connect a slider to a parameter, e.g., the width or curvature of a model, and the geometry then updates in real time as the sliders are manipulated. This enables complex shapes and forms to be generated and manipulated, allowing the designer to explore the parametric design space.

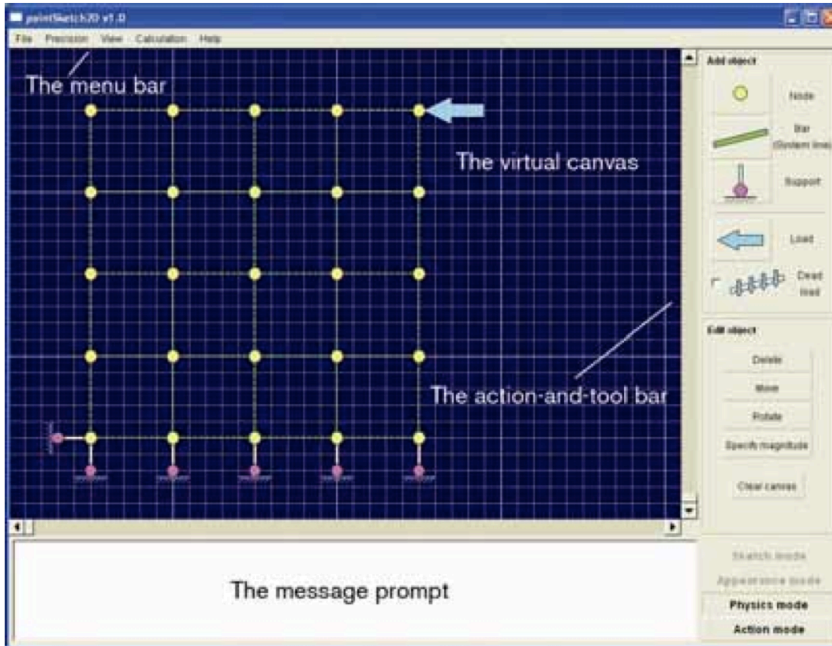

Figure 4.5: The software tool PointSketch

Grasshopper supports many plug-ins that can be combined with one another. For example, Karamba [?] can be used to provide structural performance feedback within the parametric modeler.

4.3 EXISTING CONCEPTUAL DESIGN TOOLS

“Geometry and algorithms can exist in the abstract, but to be of any practical significance, to become a design tool which can be used by designers, then these have to be encapsulated in an executable form, as working software...” - Robert Aish [?]

A number of different conceptual design tools exist. In the following, they have been divided into categories depending on the computational methods that they employ.

4.3.1 Real-time analysis tools

This type of conceptual design tool makes use of simple mathematical models to provide users with real-time feedback from structural analysis. A number of such tools have been developed; the first two, named PointSketch [?] (see Figure 4.5) and Arcade [?], were developed in parallel and released in 2006. Using these software tools, users can create structural models using

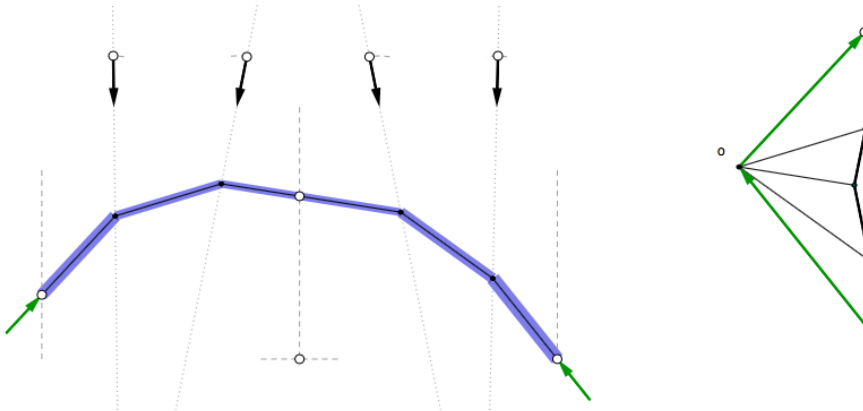

Figure 4.6: The interactive graphic statics software Equilibrium [?]

mouse and keyboard input. Forces can then be applied to the models, and the results are visualized in real time.

The first tools were developed in academia, but industry has always shown an interest in the concept. Autodesk launched a new application in 2011 named ForceEffect [?], which is available as both a tablet and web application. The application enables designers to analyze and visualize two-dimensional truss structures. The tablet application utilizes a direct manipulation user interface style whereby users can make changes to the model by directly touching the objects. The commercial finite element (FE) software SAP2000 [?] launched a live model feature in 2012. This feature enables real-time feedback from deformations and forces applied to truss structures [?].

Recently, an interactive physics engine was developed to create a game-inspired user experience for design and education [?]. This physics engine has been used to create an interactive game called Catastrophe, which aims to teach users which elements are critical to system stability through play.

4.3.2 Graphic statics tools

Multiple graphic statics computational design tools have been developed; they make use of the simplicity of graphic statics to allow the computations to run in real time. The first such application was ActiveStatics [?], a web-based tool that allows users to explore graphic statics. The focus of this tool is on teaching how graphic statics works, and extensive examples are available. A very similar version, named Equilibrium [?], was later developed (see Figure 4.6). A similar design tool that makes use of a particle-spring system for computations is CADenary [?].

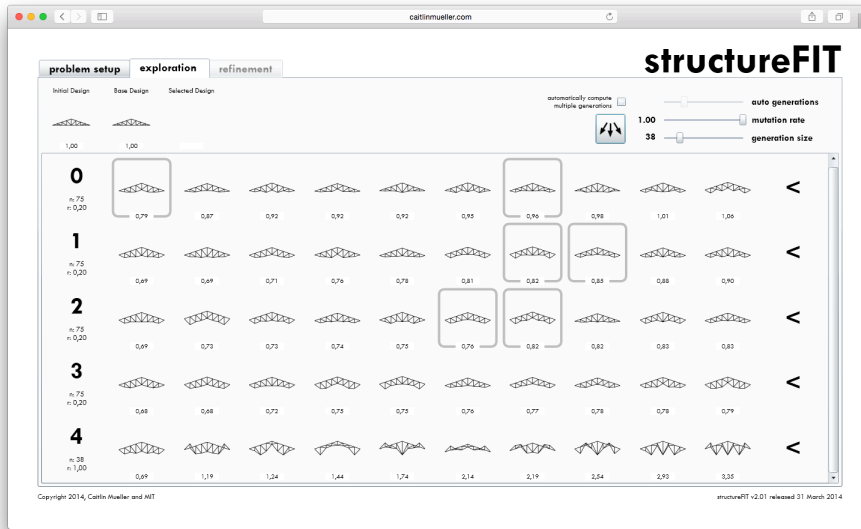

Figure 4.7: Screenshot of StructureFIT

4.3.3 Interactive optimization design tools

Genetic algorithms can easily be used for interactive optimization in which users can intervene in the selection process and direct the population in the desired direction. Such applications have been developed for conceptual structural design to allow the generation and analysis of simple structures. One such tool is von Buelow’s interactive evolutionary design tool [?], which supports both 2D and 3D structures.

A similar tool, developed as a web application, is named StructureFIT [?, ?] (see Figure 4.7). This software tool has a direct manipulation mode whereby users can further explore the generated structures by moving nodes and observing an updated relative performance index in real time. Another version of this tool, named Stormcloud [?], has been developed for Grasshopper [?].

4.3.4 Topological optimization design tools

Two other applications that were developed in academia for design exploration through the use of topological optimization are ForcePad [?] (see Figure 4.8) and TopOpt [?]. In these two applications, a 2D geometry is modeled using conventional drawing tools, a metaphor for “drawing with stiffness.” Topological optimization is then performed on the geometry, and the resulting optimized shape is visualized. These applications also have an interactive mode whereby forces can be manipulated and the resulting stresses updated in real time.

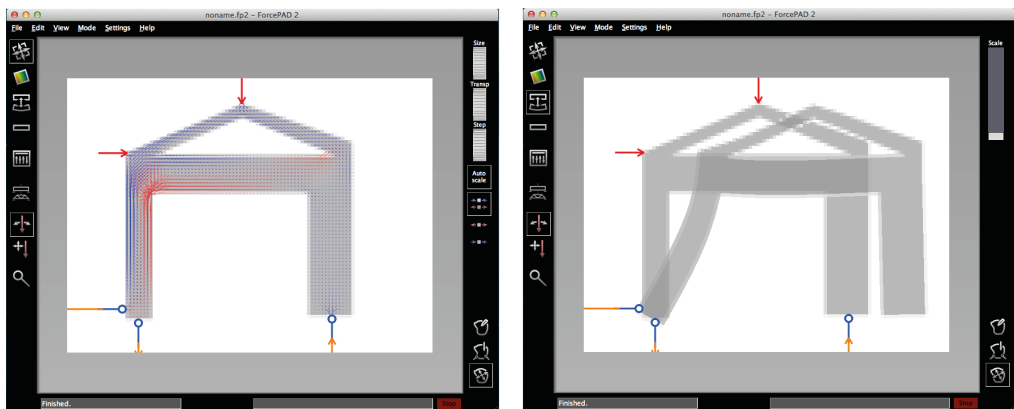

Figure 4.8: Software tool ForcePad

5 Integrating structural feedback in conceptual design tools

In the conventional workflow, the architect uses geometric modeling tools and the engineer deploys structural analysis tools in sequential steps. Parametric modeling tools offer an improvement to this workflow, as structural analysis plug-ins are available. This allows the user to obtain structural feedback earlier in the design phase, but still as a sequential step to the geometric modeling. The present work aims to improve the workflow by integrating structural feedback with geometric modeling. However, this creates new demands on conceptual design tools.

5.1 HUMAN–COMPUTER INTERACTION

Conceptual design tools should inspire and encourage users to explore design alternatives. This places demands on the human–computer interaction of such tools. The tools need to be interactive and allow users to quickly create new models, or to make changes to existing models.

Direct manipulation is a human–computer interaction style that enables users to directly manipulate objects on the screen. By doing so, the perceptual and cognitive resources required to understand and operate the user interface are reduced. Paper A describes a conceptual design tool that employs a very direct manipulation style in a user interface for 2D models. This style is achieved by taking advantage of a multi-touch screen, which literally closes the gap between the human and the computer. Using this tool, users can input a structural model using gestures similar to those found in drawing applications for tablets (see Figure 5.1). This allows users to quickly explore different design alternatives.

Achieving a very direct manipulation style in 3D has been made possible by the emergence of new 3D input controllers. This creates an opportunity to create conceptual design tools with a very direct manipulation style for 3D. In Paper B, this opportunity has been explored where a developed conceptual design tool that employs a 3D input controller named the Leap Motion Controller is presented.

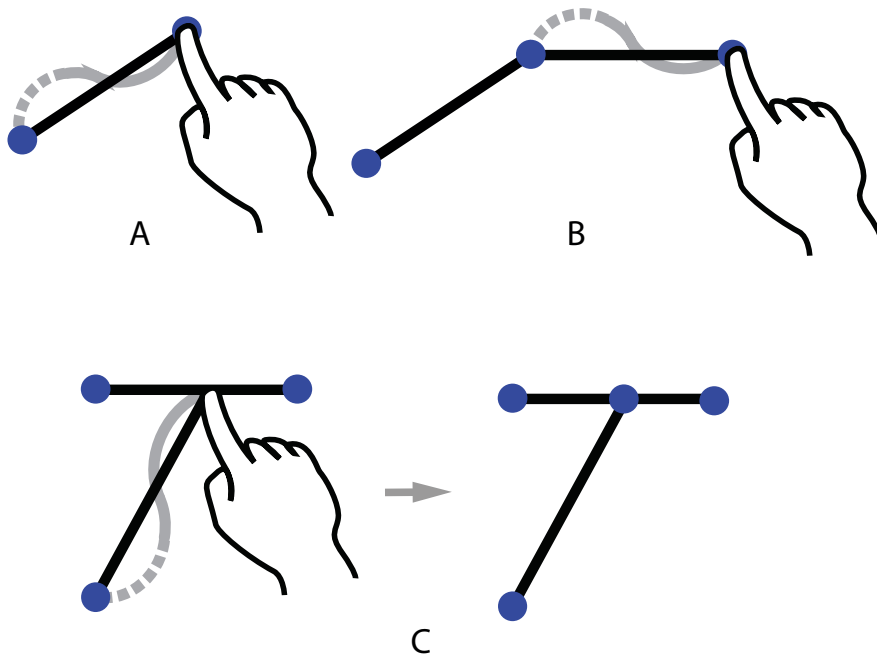

Figure 5.1: Modeling gestures in the developed application, Sketch a Frame

In Paper A, a very direct manipulation cycle is proposed to further improve the interactivity of the user interface in conceptual design applications. As the user is modeling, computations are continuously performed, and the result is automatically visualized once the modeled structure is in static equilibrium. This removes the need for a specific “compute step,” and further integrates structural feedback into the geometric modeling. This direct manipulation cycle is also employed in the application developed in Paper B.

5.2 STRUCTURAL FEEDBACK

To integrate structural feedback into conceptual design applications, structural analysis must be integrated into the geometrical modeling phase. The feedback should be easy to understand and provide valuable information about the structural behavior and performance of the design.

In the applications developed in Papers A and B, an external force can be applied to the modeled structure. If the model is in static equilibrium, the resulting deformations can be visualized in real time. The user can then adjust the forces using direct manipulation, and observe in real time how the structural deformation responds. In Paper A, when an external force is applied, the resulting normal forces and the moment envelope can also be visualized in real time. This can improve the user’s understanding of how the structure responds to external forces, how stresses propagate through the different members, and the stiffness of the structure in different directions.

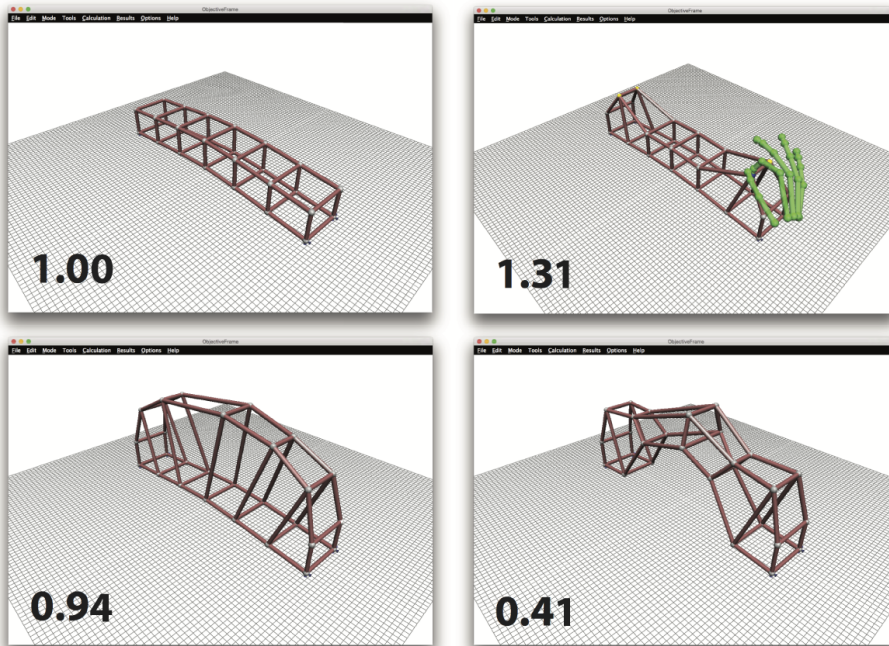

Figure 5.2: Geometric modeling with real-time performance index

The structural feedback should be easy to understand. In Paper B, the model is manipulated by the previously described direct manipulation methods, and users are simultaneously presented with a performance index that measures how well the structure is performing. This performance index is the normalized strain energy of the model; thus, a lower number corresponds to a better-performing structure (see Figure 5.2). Using a single value to represent the performance of a structure makes it easy for users to understand how geometrical modifications affect the structural performance.

5.3 STRUCTURAL OPTIMIZATION

Integrating structural optimization into conceptual structural design has the possibility to not only provide feedback about the structural performance, but also to guide the user towards geometries that are structurally sound.

A genetic algorithm for shape optimization is implemented in the application described in Paper A. Users first select which nodes can be moved by the optimizer and in which direction (vertical or horizontal) they can be moved. The optimization is then executed to minimize the strain energy. Once the analysis is complete, the best-performing structure is visualized (see Figure 5.3).

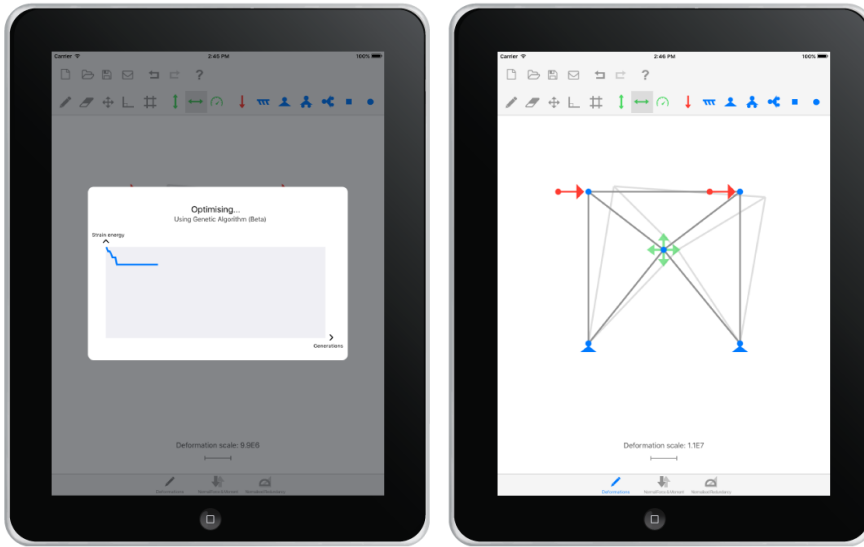

Figure 5.3: Genetic algorithm optimization in Sketch a Frame

Form-finding can be used to identify the static equilibrium for a structure under load. In Paper B, the dynamic relaxation method is implemented to enable form-finding in an interactive 3D environment. Users can further explore the form-found structure by applying and manipulating an external force. A point load can be used to move away from the optimal solution in order to find other interesting sub-optimal solutions that might be more aesthetically attractive. The point load can also, for example, represent a supporting column or a hanging installation in the structure.

5.4 VISUAL REPRESENTATIONS

After structural analysis computations have been performed, the result can be visualized. For conceptual structural design tools, visualization should ideally allow users to understand the results quickly. One such example is graphic statics, which visualizes forces as line lengths in a force diagram. Compared to using colors to represent the magnitude of the forces, this is beneficial to users' understanding as it removes a layer of abstraction. Users can immediately understand the magnitude of the forces without the need for any form of colorbar.

Dynamic behavior can be visualized using animations, as in the application developed in Paper A. If a force is applied to a model which is not in static equilibrium, the resulting rigid body motion is visualized using an animation. This allows users to quickly understand that the model is not in static equilibrium, and how it needs to be modified in order to be in static equilibrium.

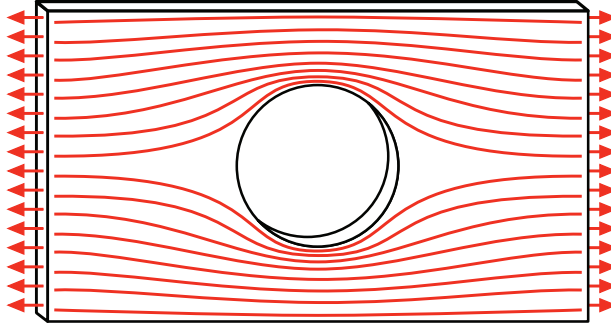

Figure 5.4: Stress lines for a 2D problem

5.4.1 Example - Stress lines

The structural behavior of 1D elements, such as bar and beam elements, is easier to understand than that of higher-dimensional elements. Higher-dimensional elements have a more complex structural behavior. For 2D structural elements, the internal stresses can be computed and used to compute lines representing how the external load flows through the structure towards the boundaries, see Figure 5.4. In the Z-direction, this can be described as [?]:

$$\frac{\delta \tau_{xz}}{\delta x} + \frac{\delta \tau_{yz}}{\delta y} + \frac{\delta \sigma_z}{\delta z} = 0$$

The author has explored how stress lines can be extended into 3D using volumetric elements. The idea for the algorithm and the results are shown in Figure 5.5. Volumetric elements are colored according to the von Mises stress, and the green dots denote boundary conditions. However, this method has some drawbacks: it is not clear how to interpret the lines, the results are sensitive to the mesh size, and the computational load is significant. Additionally, only the internal stresses acting in the Z-direction are considered here.

Although, the method described here have to be developed further. There is a need for developing better methods for visualizing results in more complex situations.

1. Algorithm starts from the top and moves down one plane at a time.

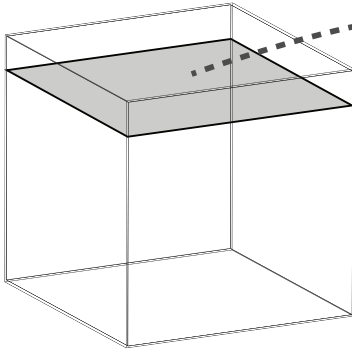

2. Computes the total stress along the black dashed line. And find where accumulated stress along the line = total stress / number stress lines

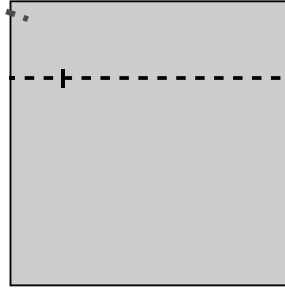

3. Process is repeated in both directions until a position for a point is found

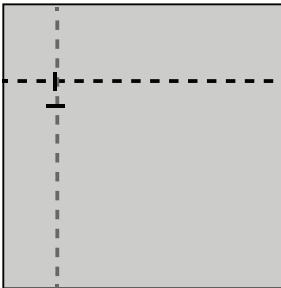

4. All the points in the plane are computed, and then repeated for the next plane. Stress lines are visualised between the points.

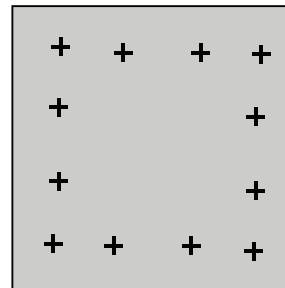

Result visualised, green dots are pinned boundary conditions:

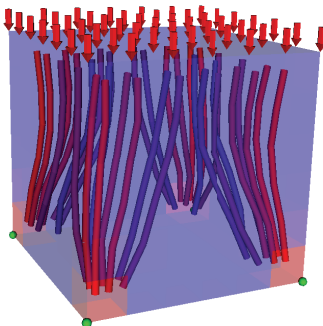

Algorithm used on an arch:

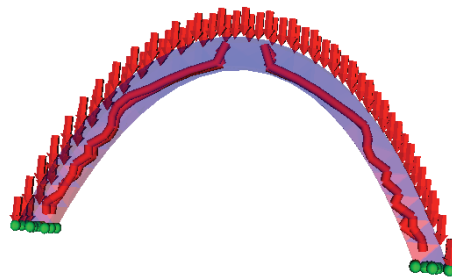

Figure 5.5: Computing stress lines for 3D

6 Summary of appended papers

6.1 PAPER A

A tablet computer application for conceptual design

D. Åkesson, Lund University

J. Lindemann, Lund University

Accepted for publication in Engineering and Computational Mechanics, 2015

SUMMARY

A tablet computer application (named Sketch a Frame) has been developed for conceptual design. The application uses a direct manipulation cycle, where the result is computed and visualized in real time once the structural model is stable. This moves away from the step-by-step workflow of conventional structural analysis software. If the model is not stable and a force is applied, the first modal shape is visualized in the form of an animation.

The application presents various computational results, such as the normal force, moment envelope, stress, and normalized redundancy. No numerical values are presented to the user; this is a design decision to encourage the user to focus on the general structural behavior rather than the exact numerical results.

The application has a very direct manipulation user interface that has not previously been used for this type of application.

Contribution

As first author, I performed all of the new implementations involved in this project. I also wrote the paper. Jonas Lindemann developed the initial idea, and supervised the work.

6.2 PAPER B

Using 3D direct manipulation for real-time structural design exploration

D. Åkesson, Lund University

C. Mueller, Massachusetts Institute of Technology

Submitted

Summary

A proof-of-concept for a conceptual design application has been developed, with an unprecedented very direct manipulation user interface for 3D. A pre-existing application named ObjectiveFrame [?] has been combined with a 3D input device named the Leap Motion controller, allowing the user to directly interact with a structural model using hand gestures.

Three different cases were implemented:

- *Structural feedback* – The user can apply a force to a structure and manipulate the model by interacting with their hands. This creates a metaphor for the user identifying with how the structure feels.
- *Performance feedback* – The user can move nodes by interacting with the model using their hands. A performance index is presented to the user to provide feedback on how geometric manipulations affect the structural performance.
- *Dynamic relaxation* – The dynamic relaxation method is used to model the manipulation of a gravity load and a point load. This creates an interactive case in which the structure constantly converges to the static equilibrium and the results are visualized using an animation .

Contribution

As first author, I performed all of the new implementations involved in this project. I also wrote the paper. Caitlin Mueller supervised the work and shared ideas on the development of the application. She also assisted in communicating the novelty of the application in the paper.

7 Results & discussion

A summary of the evaluated conceptual design tools can be seen in Figure 7.1, where the tools are grouped according to the number of dimensions and the manipulation experience. The two developed applications have a higher degree of direct manipulation in 2D and 3D than other existing software for conceptual design. This has been achieved by using novel technology: the multi-touch user interface for 2D and the Leap Motion Controller for 3D.

This thesis responds to a need for new, more intuitive and natural interaction modes in computational design and analysis. Very direct manipulation represents a significant improvement on the direct manipulation paradigms that are prevalent in CAD. New technologies like the Leap Motion Controller and the multi-touch interface open up unprecedented possibilities for engaging users in the exploration and design of structures. This will improve users' understanding of the structural behavior of a model and their cognitive engagement in the task performed, and encourage further design exploration.

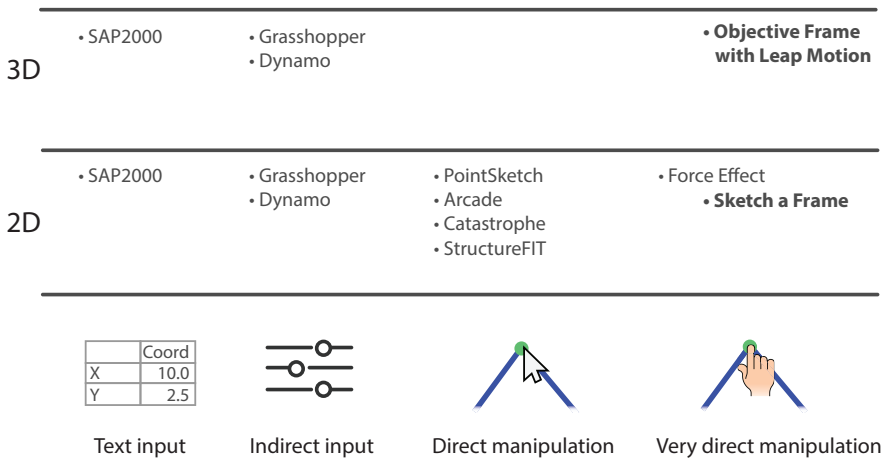

Figure 7.1: Previous work summarized, present work in bold

7.1 SUMMARY OF INTELLECTUAL CONTRIBUTIONS

- This thesis includes a critical review of existing tools and techniques for design manipulation in conceptual CAD.
- Paper A proposes a new direct manipulation cycle that automatically computes and presents the result once a structure is in static equilibrium.
- Paper A introduces new multi-touch interaction models for conceptual structural design on tablets.
- Paper B describes the first method for very direct manipulation as a human–computer interaction mode for 3D structures, based on new 3D input devices such as the Leap Motion Controller.
- Paper B introduces a design tool that allows users to interact with 3D structures through very direct manipulation.
- Paper B demonstrates the potential applications of 3D input devices through three case studies.

7.2 FUTURE WORK

The Leap Motion Controller's SDK supports virtual reality glasses such as the Oculus Rift. Combining the two could create a virtual reality application in which users can experience the structure in 3D, interact with it, and make changes using their hands.

This could potentially be developed in a game environment, where the structure is visualized in the intended context, i.e., the building site. A game engine would enable real-time renderings of the structure within this context. Designers would then be able to perform manipulations, guided by performance feedback, on the rendered structure.

Other existing design methods could be combined with this design environment, such as interactive optimization with the use of genetic algorithms. To improve the computation speed and allow the rapid generation of new designs, the design space could be approximated with the help of artificial neural networks, also known as surrogate modeling. This would allow for more advanced structural models to be used for interactive optimization.

Finally, it is necessary to evaluate and, if possible, also quantify the impact of the conceptual structural design tools on the design process. Therefore, it is important to perform case studies in future work.

Part II

Appended publications

Paper A

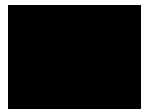

This paper is only available online or in the printed version of the thesis.

Paper B

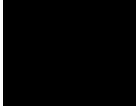

Using 3D direct manipulation for real-time structural design exploration

D. Åkesson ^A

C. Mueller ^B

A. PhD Student, Lund University, Lund, Sweden

B. Assistant Professor, Massachusetts Institute of Technology, Boston, MA, USA

Abstract

The impact of decisions on the design process is initially high and declines as the design matures. However, few computational tools are available for the early design phase; thus, an opportunity exists to create such tools. New technology opens up new possibilities to create new and novel computational tools. In this work, an existing application is adapted for a new three-dimensional (3D) input device called the Leap Motion Controller. The controller allows the user to interact with 3D objects on a screen using his/her fingers and hands. The result of this work is a conceptual design application that enables very direct manipulation of 3D objects on the screen to a level that has not been achieved before for this type of application in 3D. An improved human-computer interaction can potentially improve the user's understanding of the structural behavior of a model, cognitive engagement in the design task, and encourage further design exploration. Three different cases are implemented to enable the user to explore different design options with emphasis on geometrical form, as this has the greatest potential to improve structural performance. These case studies demonstrate a new potential for building engineering intuition and improving design space exploration through very direct manipulation in 3D.

Keywords

Interactive structural analysis; Interactive structural form finding; 3D input device; Dynamic relaxation; Conceptual structural design

1 Introduction

The object of this paper is to demonstrate how an interactive three-dimensional (3D) environment can improve conceptual structural design. The goal is to improve the user's understanding of the structural behavior of a model and illustrate how geometrical modifications can change its structural performance.

1.1 Conceptual design tools

The earliest phase of the design process is referred to as the conceptual design phase. Decisions made in this phase have the highest impact of all the decisions made throughout the design process [1]; the impact of decisions then declines as the design matures. The importance of the conceptual design phase is often overlooked and structural aspects are often only considered at a late design stage [2]. A factor contributing to this situation is that very few computational tools are available for conceptual design. The challenge of developing such computational tools is the fuzzy nature of the problem: the knowledge and constraints of the problem are imprecise and incomplete [3]. Conventional advanced structural analysis software requires precise knowledge of the problem and is not agile enough to follow a designer's iterative workflow. It has been shown that premature use of such software can negatively affect the quality of the conceptual design [4]. Conventional structural analysis software has been developed for use in the late design stage, when the major design decisions have already been made, as a tool for the engineer to verify the form.

Many different geometric modeling tools are available for architects today. These geometric modeling tools have, since their introduction in the 1980s, grown increasingly sophisticated, and have, together with the widespread perception of the benefits of technological innovation, created a more intimate relationship between technology and design. This relationship has resulted in parametric design and scripting methods that can generate complex shapes and forms [5]. The distinct separation in design that means that architects use geometric modeling tools and engineers use analysis tools further reinforces the architects role as form-giver and the engineer as form-verifier [6]. To move away from this separation, the term "designer" is used in this paper to represent either an engineer or architect.

The type of design tool that is used to generate and represent ideas also affects the quality and quantity of early prototypes. It was shown in [7] that physical prototyping generates a higher quantity of prototypes within a limited amount of time. The developed prototypes were also perceived as more novel compared to the prototypes that were developed using computer aided design (CAD) or conventional sketches. However, the prototypes that were perceived as more novel tended to fare poorly with respect to all other measurable

qualities [7]. As conceptual design is important and few conceptual design tools are available, an opportunity exists to improve the design process by developing such tools.

With new technology such as novel input devices and increased computational power comes new possibilities. The present work makes use of these possibilities to create a new way to interact with and create digital prototypes. The prototypes in this work are structural models. As a computational model is used, its measurable performance can be computed and presented in real-time to the user to potentially improve the quality of the structural models. The measurable performance and guidance in this work emphasizes the geometrical form of the structure, as this has the greatest potential to improve the structural performance. The result of the present work is a computational tool for conceptual structural design with a novel human-computer interaction interface.

1.2 Human-computer interaction

Direct manipulation is a style of human-computer interaction that has a continuous representation of the objects of interest with rapid, reversible, and incremental feedback [8]. Users can directly manipulate objects on the screen using real-world metaphors, which makes the users more engaged with their task and encouraged to explore further [9]. This is achieved by reducing the perceptual and cognitive resources required to understand and use the user interface [10].

The introduction of different input devices such as the mouse and joystick significantly improved the human-computer interaction of user interfaces, which adapted accordingly [10]. Later, when the touch screen was introduced, it had the advantage over these previous devices of a very direct method of inputting information [10]. It closed the gap between the human and computer, and the user could literally touch objects on the screen to manipulate them.

There is a wide repertoire of interaction techniques to create direct manipulation user interfaces for 3D applications using 2D input devices such as the mouse [11]. However, because these types of input devices have one degree of freedom less than the 3D user interface, there will always be a need for gestures or similar methods.

Computer games have seen an increase in the number of novel input devices along with new styles of games to address some of the limitations of conventional systems [12], e.g., the Wii Remote [13], Microsoft's Kinect for Xbox [14], and PlayStation Move [15]. These novel input devices move away from the conventional human-computer interaction to invoke an intuitive interaction that supports the natural human method of working. Games have for a long time been perceived as fun and engaging, and it has been investigated in many different disciplines whether gaming methods can improve human-computer interaction in order to create more effective, immersive, and engaging learning

or training [12]. In computer aided design tools, the user experience has been compromised by the engineering design system's step-by-step evolution. The present work moves away from the step-by-step user interface to create an interactive, gaming-like experience using a novel 3D input device.

Although beyond the scope of this paper, the interest in and development of virtual reality glasses such as the Oculus Rift [16] and PlayStation's Project Morpheus [17] have recently increased. These types of virtual reality glasses have primarily been developed for games, but other fields have also shown interest, e.g., in [18], virtual reality is used to help students understand complex structural behavior.

2 Related work

Multiple software tools for conceptual structural design that deploy truss models have previously been developed. The first two such tools, PointSketch [19] and Arcade [20], were developed in parallel and released in 2006. In both software tools, the user can create a computational model using mouse and keyboard input. Forces can then be applied to the model and the results from the computations are visualized. The two software tools were both developed in academia, but industry has shown interest in the concept.

The commercial finite element software SAP2000 launched a "model alive" feature in 2012 that enables real-time feedback for deformations and forces [21]. The software was developed for use with truss-structures. However, geometrical modifications are made through text input. Autodesk launched a new application in 2011 named ForceEffect [22], which is available both as a tablet and web application. The application was developed for designers to analyze and visualize two-dimensional truss structures. The tablet application utilizes a direct manipulation user interface style, where the user can make changes to the model by directly touching the objects. A similar application that further developed the direct manipulation of the interaction is a tablet application named Sketch-a-Frame [23]. This application updates the visualizations of the computational result in real-time as the user makes changes to the geometry, creating a very direct manipulation. Another conceptual design tool that can generate structures through interactive optimization is called StructureFIT [24,25]. This software tool also has a direct manipulation mode, where the user can further explore a generated structure by moving nodes in real-time see how a relative performance index is updated.

Recently, an interactive physics engine was developed to create a user experience inspired by games for design and education [26]. The developed physics engine has been used to create an interactive game called Catastrophe, which aims to teach users which elements are critical to system stability through play.

A popular design tool in practice is the parametric modeler Grasshopper [27], which allows the user to manipulate parametric models through the use of sliders. This can be combined with Karamba [28], which is a structural analysis tool that can also give real-time feedback as to how the structural performance changes when the input parameters are altered. A tool that implements similar functions is Autodesk’s Dynamo [29].

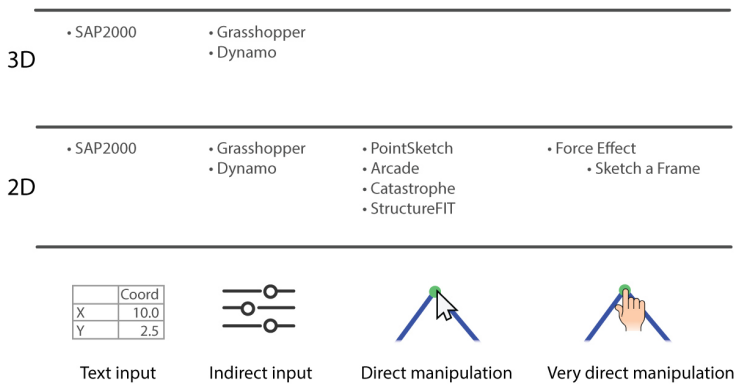

Figure 1: Summary of previous work

A summary of the evaluated conceptual design tools can be seen in Figure 1. The tools are grouped according to number of dimensions and how directly the manipulation can be experienced. Prior to the work presented here, no conceptual structural design tool has before been able to achieve very direct manipulation for 3D. A very direct manipulation user interface has so far only been achieved for 2D conceptual structural design tools. This is because of limitations of the traditional mouse and keyboard human-computer interaction with which the 3D applications were developed.

3 Methodology

The Leap Motion Controller [30] is a novel 3D input device. It can, with the use of infrared cameras, create a virtual model of a user’s hands that are in the field of vision of the controller, as shown in Figure 2. This makes it possible to allow users to very directly manipulate representations of objects in 3D—which has the potential to improve the human-computer interaction of structural conceptual design applications. Improved interaction in such applications could potentially improve the user’s understanding of the structural behavior of a model, cognitive engagement in the design task, and encourage further design exploration. The present work shows an implementation with a very direct manipulation for 3D that has not been achieved before for conceptual structural design tools.



Figure 2: Leap Motion Controller in use

3.1 Leap Motion Controller

A new 3D input device for computers was launched in July 2013 called the Leap Motion Controller [30]. By connecting the controller to a computer and placing it in front of the user, it can track the movement of fingers, hands, and tools with sub millimeter precision without any visible latency [30]. A software development kit (SDK) is available and supports most common programming languages [31], which can be used to implement support for the controller in existing applications.

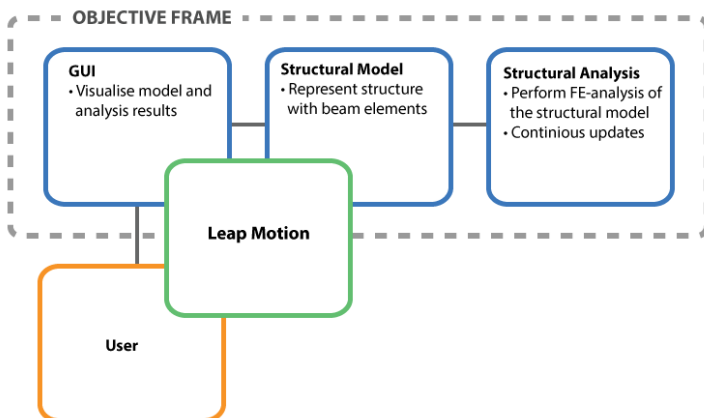

Figure 3: Conceptual diagram of how the Leap Motion Controller integrates into the existing conceptual design application ObjectiveFrame.

The SDK interprets the data from the controller's cameras and creates computational models of any hands or tools (e.g., a pen) that are in the field of vision of the controller.

Using the SDK to integrate it with an application, the computational model can be accessed through the application programming interface (API), which has functions to return the positions and direction-vectors of hands, fingers, and tools in 3D. This can be used to build and visualize a virtual model of a hand or tool that can directly interact with the 3D objects on the screen. The SDK also has built-in support for gestures that can be used to call actions. This creates the potential to create very direct user interfaces for 3D, similar to the possibilities that the multi-touch user interface created for 2D.

However, new input devices require that software adapt accordingly in order to be successful [10]; thus, new 3D input devices are heavily dependent on software developers that can create new novel user interfaces.

3.2 Detailed implementation

The work in this paper builds on an existing application that was developed for conceptual structural design named ObjectiveFrame [32]. The application was developed in the C++ programming language and uses the FLTK toolkit [33] to create the graphical user interface (GUI) and the Newmat matrix library [34] to perform matrix operations.

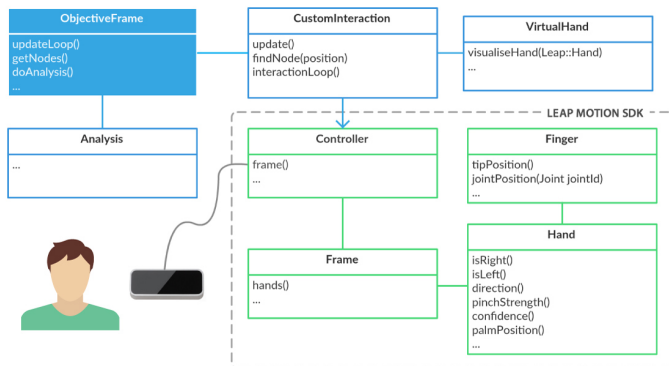

Figure 4: Diagram of how the Leap Motion SDK is integrated with the existing application.

When an instance of the class *Controller* is instantiated, the Leap Motion SDK creates a computational model of the objects in its vision field. The ObjectiveFrame application has an update cycle in which the objects of representation are continuously updated. The class *Controller* is queried at each update to obtain an updated *Frame* that contains information regarding the computational models.

Three different cases have been implemented in the existing application to demonstrate how the Leap Motion Controller can be used in the conceptual design phase.

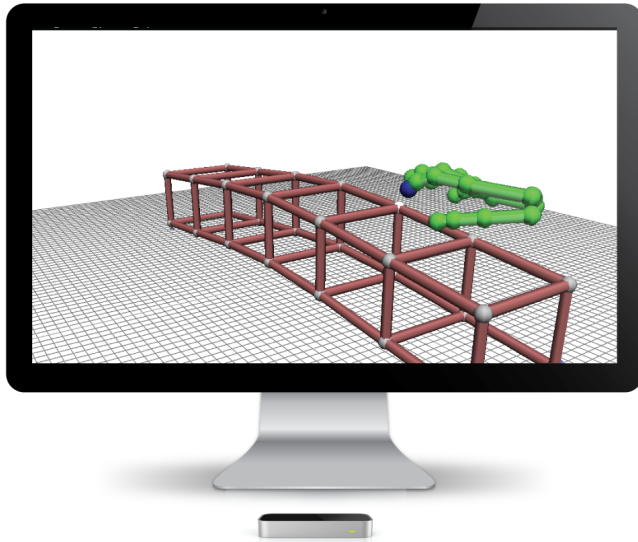

Figure 5: System setup with screenshot from the developed application.

3.3 Direct manipulation interaction model

The data from the Leap Motion SDK is used in the developed application to visualize a virtual model of the user's right hand. The tip of the index finger on the virtual hand is colored blue, as shown in Figure 6—this fingertip is used to select nodes in the 3D space. When the index fingertip position is within a set distance of a node, the node is highlighted. The user can then perform a pinch gesture (see Figure 6) to interact with the highlighted node.

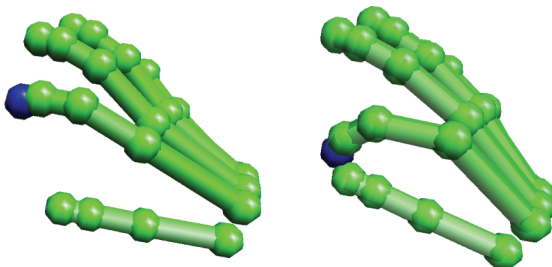

Figure 6: Pinch gesture visualized using the virtual hand model.

The right hand is used to interact with the structure while the left hand simultaneously controls the point of view, i.e., the location and angle at which the model is observed. Moving the palm closer or further away from the controller zooms out or in, respectively. This is a direct manipulation metaphor for pushing the model away. The palm position can also be used to rotate the point of view around the model by moving the palm

sideways. The angle of the hand is used to control the angle at which the model is observed.

The position of the virtual hand is relative to the point of the view. Thus, when the user rotates the view, the virtual hand is rotated accordingly around the center of the view. This is in line with the metaphor in which the user reaches into the monitor to interact with the structural model. The Leap Motion SDK also has a confidence parameter. This parameter is lowered if the view is obstructed, e.g., if the left hand obstructs the view of the right hand. This is visualized using the opacity of the right hand to indicate the user that the view is obstructed.

4 Structural analysis for conceptual design

The *Analysis* block in Figure 4 shows the numerical analysis methods that have been implemented in the application to enable structural performance feedback and guidance in the application. In conceptual structural design, a simple mathematical model such as a truss or frame is advantageous for representing a structure [35]. The objective is a general understanding of the structural behavior and numerical precision is of less importance. In later design stages, the simple mathematical model can be substituted with a more advanced mathematical model for improved accuracy.

4.1 Structural analysis

To enable the application to visualize deformations and normalized structural performance, finite element analysis was implemented in the application. The application uses 3D beam finite elements that can be used to create frames or trusses to represent structures. Every beam element has two nodes—each has six degrees of freedom: three rotational and three translational ones [36]. The structural response is computed using

$$\mathbf{K}u = f$$

where \mathbf{K} is the global stiffness matrix, u the displacement vector, and f the force vector. The compliance of the structure is the work (or strain energy) performed by the truss, and is the sum of the forces multiplied by the displacements:

$$W = \frac{1}{2} f^T u$$

This can be rewritten as

$$W = \frac{1}{2} u^T \mathbf{K}u$$

Ideally, the strain energy is a small number that corresponds to an efficient structure. To convey how geometrical modifications change the structural performance—the strain energy of the modified geometry is normalized in the developed application with the initial strain energy. The result is the normalized strain energy, a measure of how well the structure is performing.

4.2 Form finding

The process of designing form-found shapes is called form finding. Either physical models or numerical simulations can be used in this process, where the aim is to find the form for a structure under a load such that static equilibrium is satisfied. The static equilibrium corresponds to a structure that can support the applied load using only compression, and thus is a very efficient structure. For physical models, a hanging chain or cloth can be used to find the static equilibrium.

A number of different numerical methods exist to computationally find the form where static equilibrium is satisfied. The numerical method used in this work is dynamic relaxation, which is a method to solve a set of non-linear equations invented by Alistair Day in 1965 [37]. The method computes the movement of a structure over time to find equilibrium between the internal and external forces.

At each time step Δt , the internal forces for all elements are computed from nodal displacements u . The residual R can be computed using

$$R = f_{ext.} - f_{int.}$$

Using Newton's second law, the acceleration (derivative of the velocity with respect to time) can be computed as follows (at node i , in the x -direction, at time t)

$$R_{ix}^t = M_i \dot{v}_{ix}^t$$

where M_i is a lumped, fictitious mass at node i . To enforce boundary conditions, the residual is set to zero for the corresponding degrees of freedom. With a known time step, the velocity of node i in the x -direction can be computed using the finite difference method

$$v_{ix}^{t+\Delta t} = v_{ix}^{t-\Delta t/2} + \frac{\Delta t}{M_i} R_{ix}^t$$

With the velocity known, the updated geometry can now be updated using

$$x_i^{t+\Delta t} = x_i^t + \Delta t \cdot v_{ix}^{t-\Delta t/2}$$

After the geometry is updated, an iteration is complete and the computations start over, by again computing the residual. The geometry is modified at each iteration until equilibrium between the external and internal forces has been reached. Different types of damping such as kinetic or viscous damping can be used to get the solution to converge. In the present work, the velocities are set to zero in even intervals to obtain the desired dynamic behavior.

5 Case studies

The material parameters are not important in the following conceptual design case studies; however, they have a minor impact of the results and are therefore presented in Table 1.

Young's modulus	$2,1 \cdot 10^9$
Area	$3,5 \cdot 10^{-3}$
Second moment of inertia	$5,3 \cdot 10^{-6}$

Table 1: Material properties (representing a steel tube) used in this study

5.1 Case I: Structural response

In this case study, a point load can be applied to a structure, and the resulting deformations are then visualized in real-time. When a pinch gesture is performed on a node, a point load is applied. Then, as the user moves the pinched fingers away from the node, the applied force changes direction and magnitude accordingly. Thus, the further the user moves the hand from the start position, the larger the magnitude of the applied force. The structural deformations are continuously computed and visualized for the user. As the pinch gesture is released, the applied force is removed and the structure is visualized in its undeformed shape.

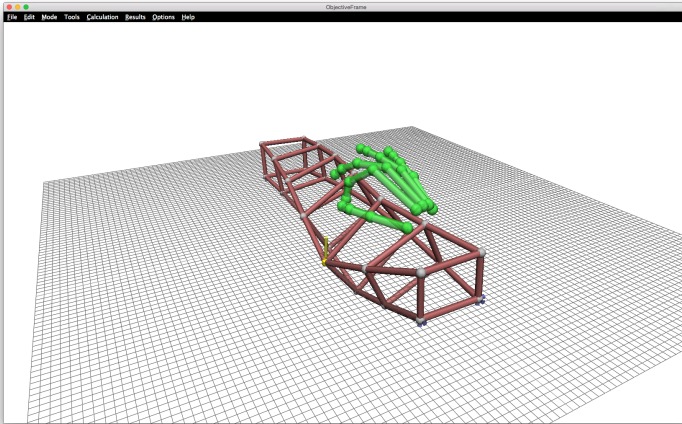

Figure 7: Structural response visualized in real-time

The scaling of the structural response is automatic and relative to the stiffness in the node where the force is applied. The applied force for node I in the x-direction is computed as follows:

$$f_{ix} = P_{currentx} - P_{startx}$$

where P_{startx} is the location of the index finger when the pinch gesture is performed and $P_{currentx}$ is the current position of the index finger.

5.2 Case II: Performance feedback

In this case, the user can move the nodes of a structural model using the pinch gesture. The strain energy of the structural model is continuously computed, normalized, and visualized on the screen for the user. The strain energy is normalized with the initial strain energy, thus the normalized strain energy is initially 1.0, where a lower value corresponds to a better performing structure.

An example of the design exploration process is shown in Figure 8; in this example, symmetry along the depth and width of the model is enforced. Thus, when a node is moved, three other nodes move to enforce symmetry. Enforcing symmetry makes the modeling process faster and different designs can easily be evaluated.

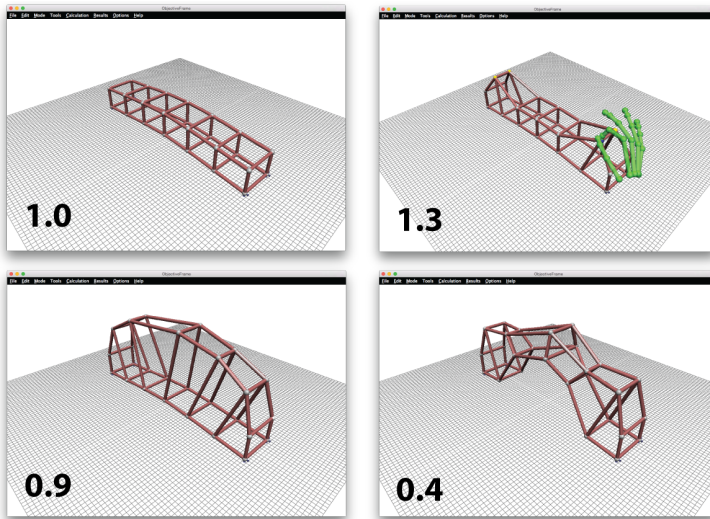

Figure 8: Design process with normalized strain energy

5.3 Case III: Dynamic relaxation

A dynamic relaxation method has also been implemented in the application. In this case, the geometry is computed and updated once every time the application refreshes. This results in an interactive application where the user can observe how the geometry is updated and modified until static equilibrium is reached.

In the following examples, a negative gravity load has been applied to the nodes. The user can then, by using the same interaction as described in Case I, apply a point load to any node. The benefit of using dynamic relaxation is that the geometry will start to converge towards the new static equilibrium even if the static equilibrium was not found for the parent load. This improves the interactivity of the application by following the direct manipulation guideline of continuously updating the object of interest. In Figure 9, an example is shown that corresponds to the physical prototype of a hanging chain.

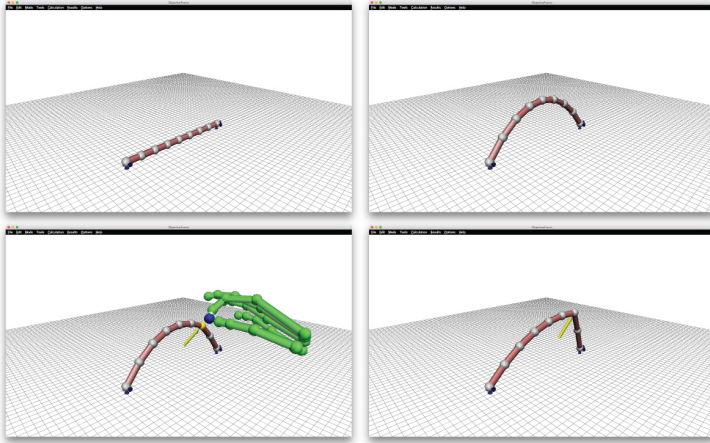

Figure 9: Educational example—the upper left image shows the initial geometry, and the upper right image shows the static equilibrium under a negative gravity load. In addition, the lower left image shows a point load being applied, and the lower right image shows the static equilibrium for a negative gravity load and point load.

As the designer applies a point load to the structure, the 3D dynamic response is interactively visualized. This can be used for educational purposes to improve the user’s understanding of the structural behavior of the model.

In Figure 10, an example is shown where the dynamic relaxation is used to find the form of a structure. The point load can here be used to move away from the optimal solution [38] in order to find other interesting sub optimal solutions that might be more aesthetically attractive to the designer. The point load can also, for example, represent a supporting column or a hanging installation in the structure.

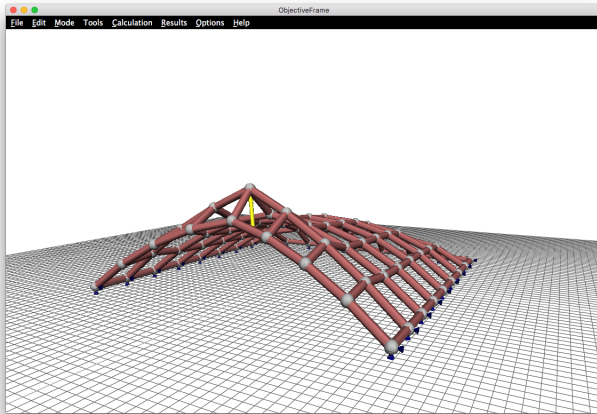

Figure 10: Example of a form-found structure using the developed application.

6 Discussion

This work shows that new 3D input devices have the potential to create very direct manipulation user interfaces for conceptual structural design, previously only achieved for 2D. The human-computer interaction in an existing application is improved, which improves the user's ability to explore different designs. The conceptual design environment is important, and it can have a big impact on the final design. This work shows an alternative user interface for the development of such tools, which in the future could potentially have a big impact on how we design structures.

The implemented methods aim to improve the designer's understanding of both the static and dynamic behavior. The implemented methods also allow the designer to navigate the design space and balance structural performance and aesthetics.

Hand gestures are used in the application to manipulate the location and angle from which the structure is observed. This could easily be implemented in existing CAD software to allow the user to more easily navigate the 3D space.

6.1 Summary of intellectual contributions

- This paper includes critical review of existing tools and techniques for design manipulation in conceptual CAD.
- It is the first to propose very direct manipulation as human-computer interaction mode for 3D structures, thanks to a new type of 3D input device such as the Leap Motion Controller
- It introduces an implemented design tool that allows users to interact with 3D structures through very direct manipulation.
- It demonstrates potential applications through three case studies.

6.2 Future work

The Leap Motion Controller's SDK supports virtual reality glasses such as the Oculus Rift. Combining the two can create a virtual reality in which the user can experience the structure in 3D, interact, and make changes to it using his/her hands.

This could potentially be developed in a game environment where the structure could be visualized in its intended context, i.e., a building site. A game engine could enable real-time renderings of the structure in its context. The designer would then be able to make manipulations, guided by performance feedback, to the rendered structure. This could improve the conceptual design process, and by doing so, have a big impact on the design process and final structure.

6.3 Concluding remarks

- This study responds to need for new, more intuitive, and natural interaction modes in computational design and analysis
- Very direct manipulation significantly improves existing direct manipulation paradigms prevalent in CAD.
- New technologies like the Leap Motion Controller open up unprecedented possibilities for engaging users in the exploration and design of 3D structures, leading to improved understanding of design options and performance in the built environment.

7 Acknowledgements

This work was supported by the Swedish strategic research program eSENCE. The author would also like to thank Jonas Lindemann for sharing the source code for ObjectiveFrame.

8 References

- [1] Wang L, Shen W, Xie H, Neelamkavil J, Pardasani A. Collaborative conceptual design—state of the art and future trends. *Comput Des* 2002;34:981–96. doi:10.1016/S0010-4485(01)00157-9.
- [2] Schlaich M. Challenges in Education—Conceptual and Structural Design. vol. 92. 31st ed., International Association for Bridge and Structural Engineering; 2006, p. 20–6.
- [3] Hsu W, Liu B. Conceptual design: issues and challenges. *Comput Des* 2000;32:849–50. doi:10.1016/S0010-4485(00)00074-9.
- [4] Fröderberg M, Crocetti R. Engineers in need of an improved conceptual design toolbox. vol. 102. 37th ed., International Association for Bridge and Structural Engineering; 2014, p. 515–21.
- [5] Sakamoto T, Ferré A. Intro. From Control to Des. *Parametr. Archit., Actar-D*; 2008, p. 5.
- [6] Mueller C, Ochsendorf J. An Integrated Computational Approach for Creative Conceptual Structural Design. In: Obrębski JB, editor. IASS, 2013.
- [7] Häggman A, Tsai G, Elsen C, Honda T, Yang MC. Connections Between the Design Tool, Design Attributes, and User Preferences in Early Stage Design. *J Mech Des* 2015;137:71408. doi:10.1115/1.4030181.
- [8] Shneiderman B. The future of interactive systems and the emergence of direct manipulation. *Behav Inf Technol* 1982;1:237–56.
- [9] Shneiderman B. Direct Manipulation for Comprehensible, Predictable and Controllable User Interfaces. *Proc. 2Nd Int. Conf. Intell. User Interfaces*, New York, NY, USA: ACM; 1997, p. 33–9. doi:10.1145/238218.238281.
- [10] Sears A, Plaisant C, Shneiderman B. A new era for high precision touchscreens. *Adv Human-Computer Interact* 1990;3.
- [11] Nielson GM, Olsen Jr. DR. Direct Manipulation Techniques for 3D Objects Using 2D Locator Devices. *Proc. 1986 Work. Interact. 3D Graph.*, New York, NY, USA: ACM; 1987, p. 175–82. doi:10.1145/319120.319134.

- [12] Kosmadoudi Z, Lim T, Ritchie J, Louchart S, Liu Y, Sung R. Engineering design using game-enhanced CAD: The potential to augment the user experience with game elements. *Comput Des* 2013;45:777–95. doi:10.1016/j.cad.2012.08.001.
- [13] Nintendo. Nintendo Wii n.d. <http://www.nintendo.com/wiiu> (accessed October 13, 2015).
- [14] Microsoft. Kinect n.d. <http://www.xbox.com/en-US/xbox-360/accessories/kinect> (accessed October 13, 2015).
- [15] Playstation. Playstation Move n.d. <https://www.playstation.com/en-us/explore/accessories/playstation-move/> (accessed October 14, 2015).
- [16] Oculus Rift n.d. <https://www.oculus.com/> (accessed October 23, 2015).
- [17] Playstation. Project Morpheus n.d. <https://www.playstation.com/en-us/explore/project-morpheus/> (accessed October 23, 2015).
- [18] Fogarty J, El-Tawil S. Exploring Complex Spatial Arrangements and Deformations in Virtual Reality. *Struct. Congr.* 2014, n.d., p. 1089–96. doi:<http://dx.doi.org/10.1061/9780784413357.097>.
- [19] Olsson P. Conceptual studies in structural design: pointSketch—a computer based approach for use in early stages of the architectural process. Chalmers University, 2006.
- [20] Martini K. A new kind of software for teaching structural behavior and design. In: Oakley D, Smit R, editors. 2006 Build. Technol. Educ. Symp. Proc., University of Maryland; 2006, p. 279.
- [21] Clune R, Connor JJ, Ochsendorf JA, Kelliher D. An object-oriented architecture for extensible structural design software. *Comput Struct* 2012;100-101:1–17. doi:10.1016/j.compstruc.2012.02.002.
- [22] Autodesk. Industry First: Autodesk Takes Simulation Mobile with New ForceEffect App for iPad 2011. <http://news.autodesk.com/press-release/industry-first-autodesk-takes-simulation-mobile-new-forceeffect-app-ipad> (accessed October 22, 2015).
- [23] Akesson D, Lindemann J. A tablet computer application for conceptual design. *Proc ICE - Eng Comput Mech* 2015:1–8. doi:10.1680/eacm.14.00020.

- [24] Mueller C. StructureFIT n.d. <http://www.caitlinmueller.com/structurefit/> (accessed October 16, 2015).
- [25] Mueller CT, Ochsendorf JA. Combining structural performance and designer preferences in evolutionary design space exploration. *Autom Constr* 2015;52:70–82. doi:10.1016/j.autcon.2015.02.011.
- [26] Senatore G, Piker D. Interactive real-time physics. *Comput Des* 2015;61:32–41. doi:10.1016/j.cad.2014.02.007.
- [27] Grasshopper n.d. <http://www.grasshopper3d.com/> (accessed October 5, 2015).
- [28] Karamba n.d. <http://www.karamba3d.com/> (accessed October 5, 2015).
- [29] Dynamo n.d. <http://www.autodesk.com/products/dynamo-studio/overview> (accessed November 5, 2015).
- [30] Leap Motion. Leap Motion Launches World’s Most Accurate 3-D Motion Control Technology for Computin 2013. <https://www.leapmotion.com/news/leap-motion-launches-world-s-most-accurate-3-d-motion-control-technology-for-computing> (accessed October 22, 2015).
- [31] Leap Motion SDK n.d. <https://developer.leapmotion.com/> (accessed September 24, 2015).
- [32] Lindemann J, Dahlblom O, Sandberg G. ObjectiveFrame-An educational tool for understanding the behaviour of structures. *Appl. Virtual Real. Eng. Constr. Appl. Virtual Real. Curr. Initiat. Futur. Challenges AVR II CONVR*, 2001.
- [33] Fast Light Toolkit n.d. <http://www.fltk.org/> (accessed October 19, 2015).
- [34] Robert D. Newmat C++ matrix library. Newmat Doc n.d. <http://www.robertnz.net/index.html> (accessed October 22, 2015).
- [35] Schlaich J, Schafer K. Design and detailing of structural concrete using strut-and-tie models. *Struct Eng* 1991;69:113–25.
- [36] Bathe K-J. Finite element procedures. Klaus-Jurgen Bathe; 2006.
- [37] Day AS. An introduction to Dynamic Relaxation. *Eng* 1965;219.
- [38] Kilian A. Steering of form. *Shell Struct. Archit. form Find. Optim.*, Routledge; 2014, p. 131–8.