



LUND UNIVERSITY

Modeling and Dynamic Analysis of CO₂-Emission Free Power Processes in Modelica using the CombiPlant Library

Selimovic, Faruk; Eborn, Jonas; Sundén, Bengt

Published in:
Modelica 2006 Proceedings

2006

[Link to publication](#)

Citation for published version (APA):

Selimovic, F., Eborn, J., & Sundén, B. (2006). Modeling and Dynamic Analysis of CO₂-Emission Free Power Processes in Modelica using the CombiPlant Library. In *Modelica 2006 Proceedings* Modelica.

Total number of authors:
3

General rights

Unless other specific re-use rights are stated the following general rights apply:
Copyright and moral rights for the publications made accessible in the public portal are retained by the authors and/or other copyright owners and it is a condition of accessing publications that users recognise and abide by the legal requirements associated with these rights.

- Users may download and print one copy of any publication from the public portal for the purpose of private study or research.
- You may not further distribute the material or use it for any profit-making activity or commercial gain
- You may freely distribute the URL identifying the publication in the public portal

Read more about Creative commons licenses: <https://creativecommons.org/licenses/>

Take down policy

If you believe that this document breaches copyright please contact us providing details, and we will remove access to the work immediately and investigate your claim.

LUND UNIVERSITY

PO Box 117
221 00 Lund
+46 46-222 00 00

Modeling and Dynamic Analysis of CO₂-Emission Free Power Processes in Modelica using the CombiPlant Library

Jonas Eborn Faruk Selimovic† Bengt Sundén†

Modelon AB
IDEON Science Park, SE-223 70 Lund

†Department of Energy Sciences
Division of Heat Transfer
Lund Institute of Technology, Box 118 SE-221 00 Lund

Abstract

The need to reduce CO₂ emissions from fossil-fuel based power production creates the need for new power plant solutions where the CO₂ is captured and stored or reused. Different concepts to capture CO₂ fall into the three main categories:

1. Precombustion decarbonization
2. Oxy-fuel combustion
3. Post-combustion removal of carbon.

In the first two types of processes Oxygen Transport Membrane (OTM) is the key component, as pure oxygen is usually required to process reactions (e.g. Integrated Gasification Combined Cycle IGCC, Advanced Zero Emission Plant AZEP). Post-combustion removal processes can for example utilize adsorption/desorption in certain salt solutions. This paper will describe two different applications of CO₂-emission-free processes, one using an OTM, the other a high pressure post combustion removal process, the Sargas process, which has been modeled in a project with Siemens Industrial Turbomachinery AB and Alstom Power Sweden AB. All modeling work was carried out in the modeling language Modelica, which is an open standard for equation-based, object-oriented modeling of physical systems. System models have been built using the CombiPlant library, a modeling library for combined cycle power plants from Modelon AB.

Keywords: power plant modeling; OTM; CO₂-removal; oxy-fuel combustion;

1 Introduction

Future profitability of power generation will involve, besides fuel and investment costs, even a trading of plant CO₂-emissions. Today, the use of coal and other low-grade fossil fuels are dominant for power generation, about 80%. Gas fired power plants produces about 20% of the total power output and an increased number of natural gas fired combined cycle power plants would result in lowering of CO₂ emissions.

1.1 Sargas process description

Sargas AS, a Norwegian company, has developed technology for separating CO₂ and NO_x from power plant flue gas. The Sargas process is a combined cycle system consisting of a gas turbine with an external pressurized combustion chamber in combination with a conventional steam cycle. This part of the process is a modified version of existing pressurized fluidized bed combined cycle (PFBC) power plants. The removal of the CO₂ takes place at high pressure after the combustion chamber. This minimises the volume of flue gas to be purified relative to the amount of power produced, providing near full CO₂ capture (more than 95%) and substantial reduction of NO_x (5ppm).

The Sargas process flow sheet can be seen in Figure 1, along with the corresponding model diagram in Figure 2. The air from the gas turbine compressor and natural gas are combusted in the pressurized boiler. The combustion process can take place at a low level of excess air (2% O₂ in exhaust gas). This will result in a higher concentration of CO₂ in exhaust gas than in conventional gas-fired Combined Cycle Power Plants (CCPP). The combination of elevated pressure

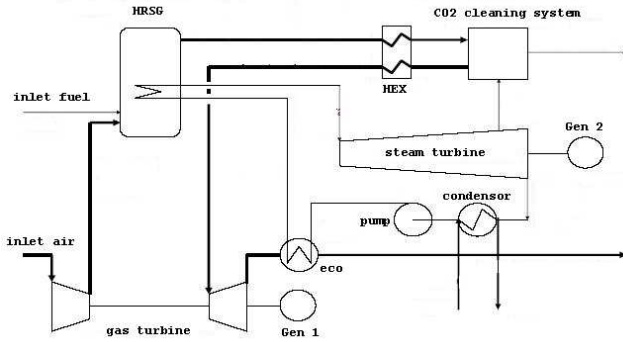

Figure 1: Sargas process flow sheet.

and high CO_2 concentration results in high CO_2 partial pressure, thus increasing the efficiency of the CO_2 separation process compared to conventional CCPP. Steam produced in the boiler is used to generate electricity from a conventional steam turbine. The temperature of boiler exhaust gas is approximately 850°C , somewhat lower than in CCPP. The exhaust gas is cooled in heat exchangers down to the optimal temperature ($\approx 70^\circ\text{C}$) for the CO_2 separation process, which is an absorption/desorption process employing a salt solution as the working fluid.

After the CO_2 separation process takes place (with an efficiency of approximately 90% in this application), the exhaust gas with less CO_2 is reheated to about 840°C and expanded through the gas turbine to produce further electricity, before passing to the stack.

1.2 Oxy-fuel emission free power cycles

Compared to the capture processes which use complicated separation processes, the oxy-fuel power cycles uses pure oxygen in the combustion of fuel. Exhaust gases resulting from the combustion will therefore consist of mainly water and carbon dioxide. The exhausts can easily be cooled to condense the water leaving the carbon dioxide for further storage. OTM is an important part of novel oxy-fuel power cycles such as AZEP and Chemical Looping Combustion (CLC) where OTM is integrated in the system to enable stoichiometric combustion with oxygen.

The key of AZEP concepts is substitution of the conventional combustion chamber in a gas turbine by a mixed conducting membrane (MCM) reactor, which combines oxygen production, fuel combustion and heat transfer [1, 2]. The MCM reactor contains oxygen transfer membrane being surrounded by two High Temperature Heat Exchangers (HTHX), which supply energy needed for oxygen transfer process. The

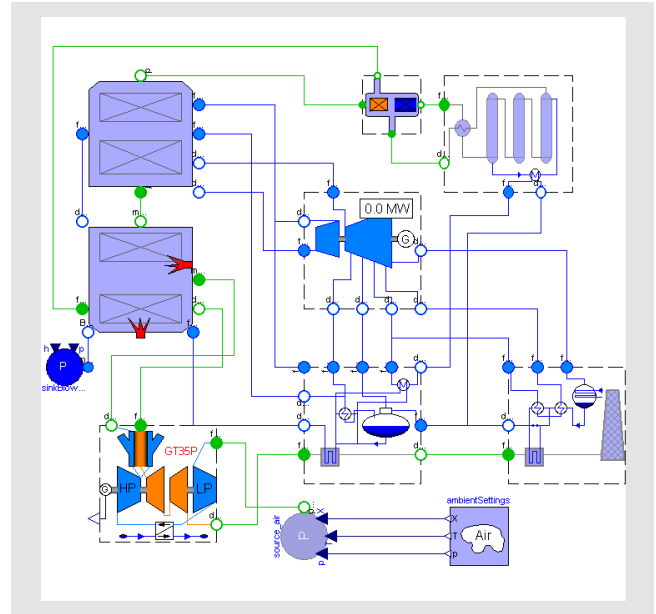

Figure 2: Sargas process model diagram as shown in Dymola window.

membrane is constructed of mixed ion electron conducting material and when heated it transfers the oxygen ions which are exchanged at surfaces with oxygen molecules [3, 4]. As can be seen from Figure 3, compressed low temperature air (500°C) from compressor enters the reactor at the first of two HTHX (Q arrows) which in turn increases the air temperature up to the needed level for oxygen permeation reaction. The oxygen migrates to the exhaust gas (called sweep gas). From the membrane section the air enters the second HTHX (upper Q arrows) where the temperature is raised to a value close to the hot exhaust gas temperature from combustor (1200°C). The hot oxygen depleted air is then led to the power generating turbine. As the oxygen is transferred to the sweep flow, excess of mass on the sweep side and deficit on the air side, respectively, will occur after the membrane section. The bleed gas heat exchanger compensates for this and increases the sweep temperature which at the final stage is used for generation of steam, in a HRSG, which is then expanded in the steam turbine.

The advantage in the power systems using oxy-fuel combustion is that it enables 100% CO_2 capture. However, the need of expensive oxygen separation methods (e.g. cryogenic separation of pressure swing absorption, PSA) would bring oxy-fuel method to its death because of a decreased thermal efficiency, down to only 10-20%. OTM is the key of oxy-fuel processes as it separates oxygen from air at low costs.

2 CombiPlant Library

The CombiPlant library is a commercial Modelica library for the unsteady (transient) simulation of Combined Cycle Power Plants and its components. The CombiPlant library uses well-known, published correlations for heat transfer and pressure drop for fluegas, steam and liquid water. Besides this more advanced user-defined correlations can be easily integrated, and also completely new models such as the oxygen membrane model built and used together with the library components.

Both gas and fluid side models in heat exchangers uses a discretized finite volume model with mass and energy balances for each volume. Two-phase behavior is captured using the integrated mean-density model [5] and by continuously tracking the phase boundary an accurate description of two-phase heat transfer is obtained. The pipe and heat exchanger models can be parametrized with different heat transfer and pressure drop models, which even can be added by the user, e.g. using proprietary correlations.

The library uses steam and fluegas medium models from the new Modelica.Media library [6, 7], which allows easy replacement of the medium models used in component and system models. The library structure contains the following packages:

ControllersAndSensors This package contains controllers and sensors for gas/water stream properties, needed for control of dynamic systems.

Examples is a package with test models and also some ready-to-use combined cycle plant section examples.

FlueGas package contains components, sources and sinks relevant for use with gas media, such as pipe, volume and combustor models.

HeatExchangers This package contains general models of heat exchangers for gas-gas or gas-water operations. Also models for steam/water plate heat exchangers are represented here.

Interfaces package contains connectors for gas and water streams. It is basically a mirror of the Modelica.Fluid and Thermal connector definitions.

Internal consists of several subpackages, providing functions for characteristic numbers, such as Reynolds, Nusselt, and Prandtl number, and other useful numerical functions. Internal also holds subpackages for user choices and component icons.

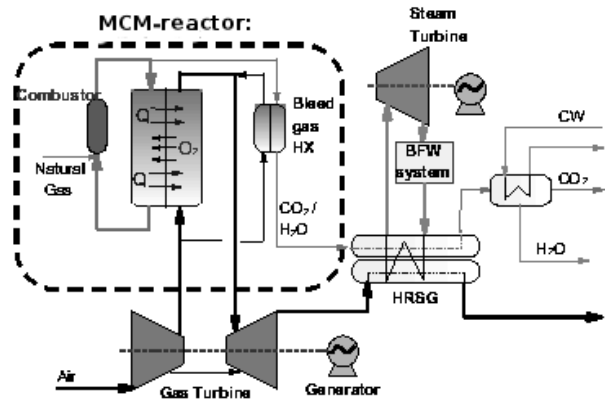

Figure 3: AZEP process flow sheet, inside the dashed square is the reactor system. (from [2])

Pumps package holds pump models described by the characteristic curve.

Water This package contains components, sources and sinks relevant for water/steam media, e.g. two-phase pipes and volumes, boiler drum, spray attemperator, and steam turbine models described by the Stodola equation.

SubComponents includes the subpackages, *Geometry* for heat exchanger geometry descriptions, *HeatTransfer* for different heat transfer correlations used in component models, and *Visualizers* with component models used for dynamic visualization of the plant and section model diagrams.

Valves package contains valves and pressure loss models.

3 Developed Models

The CombiPlant library includes components for conventional combined cycle power plant models. For the two applications described in this paper several specialized components and extensions to the CombiPlant library models were built. Some of the new components and modeling assumptions used are described in this section below.

3.1 Performance trade-offs for heat exchanger models

Cross flow gas-water heat exchangers used in the boiler, superheater and economizer sections of a power plant are modeled using a discretized model. To get

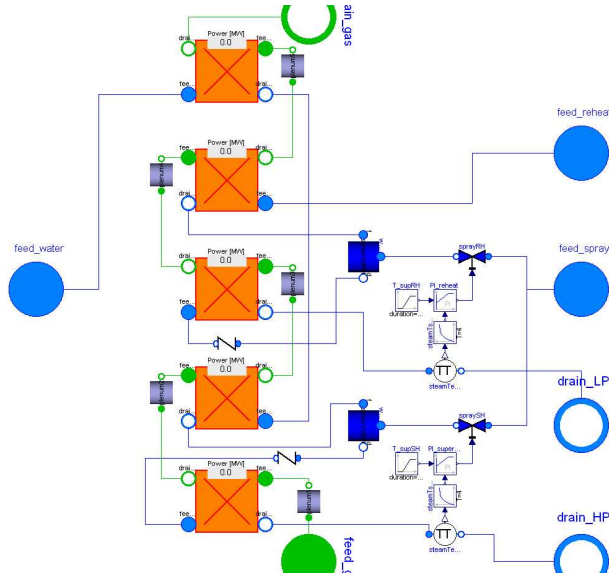

Figure 4: Superheater section model, showing example of how to combine heat exchangers with steady-state balance equations and dynamic plenum volumes.

good steady-state performance it is desirable to have high discretization, but a large number of dynamic states would give very long simulation times. As a trade-off that still retains all the relevant dynamics a quasi-static discretized model is used on the gas side of all HX's. The relevant thermal dynamics of the HX are included in the thermal inertia of the metal walls.

In the section models, several such HX's connected in series on the gas side. This would result in an undesirable static coupling between gas side balance equations, giving large non-linear equation systems that would also result in long simulation times. To avoid this situation, dynamic plenum volumes are introduced between HX's as can be seen in Figure 4. Dynamic states p , T , X are forced on the plenum volumes, using the Modelica `stateSelect` attribute. The dynamic states provide the boundary conditions for the static flow and heat transfer relations on the gas side of the HX and breaks up the large non-linear equation systems. This combination is a trade-off that provides both good steady-state and dynamic performance for discretized models of this type.

In the figure it can also be noted that the plenum volumes are coupled directly to the inlet of each HX without any separate pressure drop description. This is possible due to automatic index reduction, and has no ill effects since there are no gas volume dynamics inside the heat exchanger model.

3.2 Benfield process section model

The key feature of the Sargas process is to deliver power from natural gas without the environmental impact of fossil CO_2 emissions. This is achieved in the CO_2 removal unit, in the upper right corner of Figure 1. The process used is a so-called Benfield process, a standard commercial process using the adsorption/desorption properties of certain salt solutions to remove CO_2 . It consists of several stages of condensing and humidifying the flue gas using water, to keep the gas at ideal conditions for the adsorption process. The Benfield section model is a simplified description of the CO_2 removal process without the salt solution circulation loop included. The main purpose of the investigation was to verify the dynamic behavior with respect to the composition and thermal dynamics, and thus no detailed description of the Benfield process was needed. The important moisture and gas thermal and volume dynamics are included via lumped models of the large volumes in the scrubber, condenser, absorber/desorber and humidifier. Moisture condensation and evaporation is assumed to be instantaneous at the current saturation temperature. The absorption itself is represented by a constant efficiency parameter. The model includes the absorption heat taken from the steam flow bled from the steam turbine, as this is important for the overall energy efficiency of the process. Below are the additional mass balance equations for the absorber volume, used to calculate the mass transfer of water and CO_2 . The difference between the water saturation pressure and the actual mole fraction of steam in the gas volume is used as the driving force for mass transfer.

$$\begin{aligned} dy_{\text{sat}} &= (\text{WaterMedium.saturationPressure}(T) / p \\ &\quad - \text{mole}_y[\text{H}_2\text{O}]); \\ \text{feed.mXi_flow}[\text{H}_2\text{O}] + \text{drain.mXi_flow}[\text{H}_2\text{O}] \\ &\quad + \text{absorb_flow}[\text{H}_2\text{O}] = \\ &\quad dy_{\text{sat}} * \text{feed.mXi_flow}[\text{H}_2\text{O}]; \\ \text{feed.mXi_flow}[\text{CO}_2] * \text{eta_absorb} \\ &\quad + \text{absorb_flow}[\text{CO}_2] = 0; \end{aligned}$$

The names `feed` and `drain` refer to the gas flow connectors on the volume, the parameter `eta_absorb` is the CO_2 removal efficiency parameter.

3.3 Oxygen transport membrane reactor model

Oxygen Transport Membrane (OTM) consists of dense ceramic membrane. It is generally accepted that such dense membranes have significant future potential in the gas and energy industries with a wide variety of

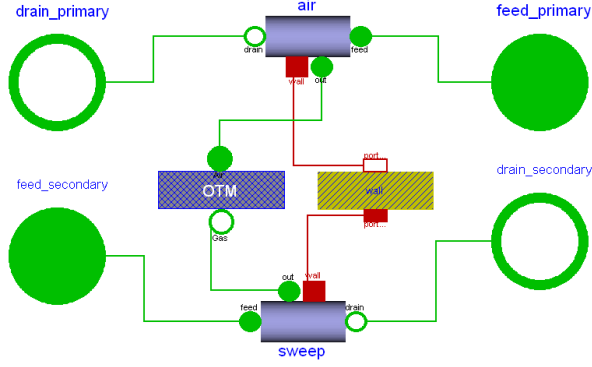

Figure 5: Model diagram view of the membrane reactor model: *OTM* -Oxygen transfer membrane, *Air* -air flow model, *Sweep* -exhaust gas flow model, *wall* -wall model for heat transfer.

applications, such as, the separation of oxygen from air and the conversion of natural gas to syngas. The OTM is usually constructed of mixed ion electron conducting material and when heated it transfers the oxygen ions which are exchanged at surfaces with oxygen molecules [3]. Energy for heating the membrane can be exchanged from process exhaust gases. The most attractive membrane materials today which have been employed successfully in membrane reactors are: $Ba_{0.5}Sr_{0.5}Co_{0.8}Fe_{0.2}O_{3-\delta}$ (BSCFO) and $BaCo_{0.4}Fe_{0.4}Zr_{0.2}O_{3-\delta}$ (BCFZO), [8].

The membrane reactor model was conducted from existing flow models from CombiPlant library with the exception of the model for oxygen transfer which in its turn is developed and introduced into library. Since the oxygen transfer model involves mass transfer operation of only oxygen as a single component, the `Modelica semiLinear` function for calculation of the fluid flow and fluid enthalpy in connectors is not suitable. The `semiLinear` function can only be applied to well mixed flows. Instead, the code below has been used. Media model of air for this case has 5 different components, (ex. Moist air with Ar, CO₂, H₂O, N₂, O₂), and the mass flow rates of the four non-permeable ones were set to zero.

```

m_flowO2 =
  J_O2*memPars.A_mem*Medium.data[5].MM;
Air.H_flow      = h_O2*m_flowO2;
Gas.H_flow      = -h_O2*m_flowO2;
Gas.mXi_flow[1:4] = 0,0,0,0;
Gas.mXi_flow[5]  = -m_flowO2;
Gas.m_flow      = -m_flowO2;
Air.mXi_flow[1:4] = 0,0,0,0;
Air.mXi_flow[5]  = m_flowO2;
Air.m_flow      = m_flowO2;

```

Gas and Air are the flow connectors on each side of the membrane, connected to the corresponding pipe model. The code above takes care of mass flow rate of oxygen and assigns this value to connector. Oxygen permeation rate J_{O_2} has been traditionally calculated by the Wagner equation:

$$j_{O_2} = \frac{1}{16F^2d} \int_{\mu_1s}^{\mu_2s} \frac{\sigma_i \sigma_e}{\sigma_i + \sigma_e} d\mu \quad (1)$$

where j is the permeation flux density of molecular oxygen, d is the membrane thickness, σ_i and σ_e are the partial ionic and electronic conductivities, μ is the oxygen chemical potential. Oxygen chemical potential is expressed here as:

$$\mu = RT \log(p_{O_2}) \quad (2)$$

Combination of eq. 2 and eq. 1 and integration of 1 with the fact that oxygen ions are much slower than electron gives following expression:

$$j_{O_2} = \frac{c_i D_a}{4d} \ln \frac{p_{O_2}^1}{p_{O_2}^2} \quad (3)$$

where c_i is the density of oxygen ions, D_a represents ambipolar diffusion coefficient of oxygen ion-electron hole pairs, d is the thickness of membrane, $p_{O_2}^1$ and $p_{O_2}^2$ is the oxygen partial pressure for low and high oxygen partial pressure sides across membrane respectively. The ambipolar conductivity was assumed to have Arrhenius dependence on temperature:

$$D_a = D_a^0 e^{\frac{E_a}{R} \left(\frac{1}{T} - \frac{1}{1273.15} \right)} \quad (4)$$

where D_a^0 is the preexponential factor and E_a is the activation energy for the ambipolar conductivity. The BSCFO membrane possesses high oxygen ion conductivity. For the predominantly BSCFO mixed-conductor the D_a^0 is expected to be close to the ionic self-diffusion coefficient D_i ($D_a \approx D_i$), and then the Nernst-Einstein equation is applicable to calculate the oxygen ionic conductivity of BSCFO:

$$D_i = \frac{RT \sigma_i}{4c_i F^2} \quad (5)$$

The experimental measured oxygen flux in [8], has been used to express correlation of ionic conductivity of BSCFO in this work, Figure 6.

4 Simulation Results

Examples of transient simulations carried out on the two types of CO₂ free power processes presented are shown here.

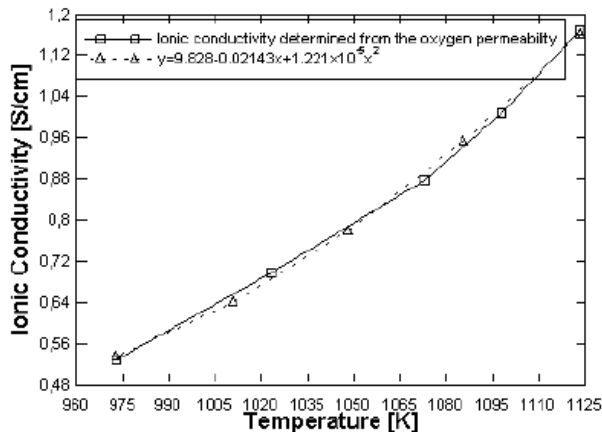

Figure 6: Oxygen ionic conductivity at different temperatures, from [8].

4.1 Load reduction transient on the Sargas plant model

To see the effects of the volume lag from the CO₂ removal plant on the power plant behavior, a load reduction transient has been conducted on the Sargas plant model. The simulation was done on a plant model without the gas turbine, with the load reduction performed by ramping the compressed air flow rate into the boiler from 100% to 80% of the design flow rate. Natural gas flow to the burners was reduced proportionally. A plot of the resulting mechanical power generated by the steam turbines is shown in Figure 7. Generators connected to the gas turbine would contribute another 15 MW at 100% load conditions.

In Figure 8 the mole fraction of CO₂ into and out of the Benfield process section is shown. The process removes 92% of the carbon dioxide in the gas flow. Dur-

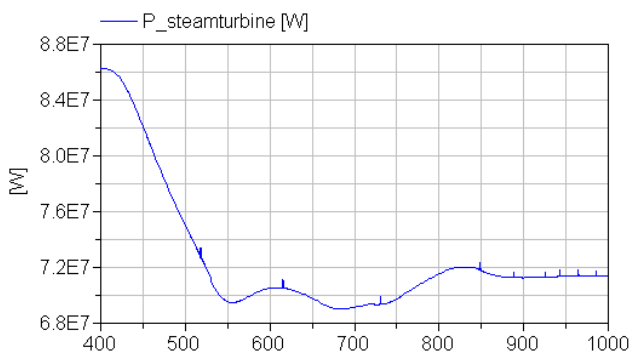

Figure 7: Total mechanical power generated by steam turbines during load turn-down on Sargas plant model.

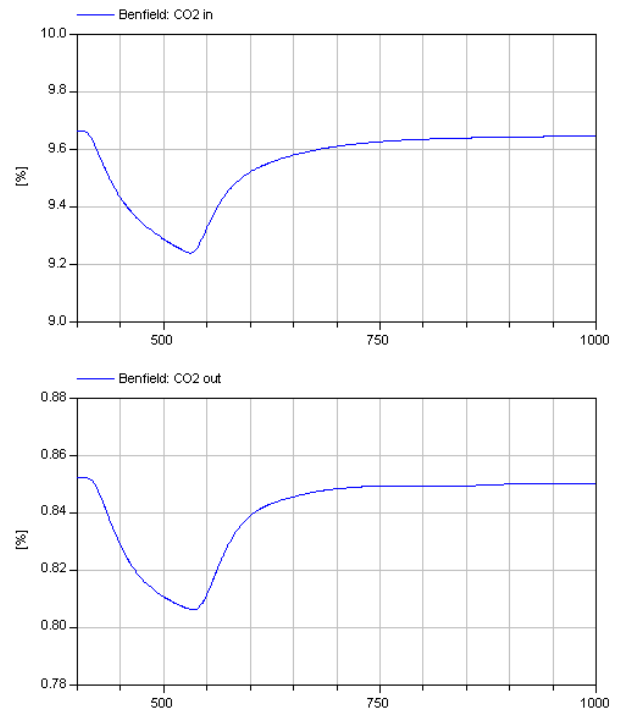

Figure 8: Mole fraction of CO₂ into and out of the Benfield plant section.

ing the load reduction transient between 400 and 520 seconds the inlet composition changes, but the outlet composition follows with little lag. The high volumetric flow rate of about 10 m³/s gives a hold-up of only a few seconds in the gas heat exchangers of the Benfield process.

Figure 9 shows the mass flow of H₂O in the flue gas stream into and out of the Benfield process section. It is important to maintain the water balance and avoid adding or removing process water. In the simulation a control valve hits the maximum limit. This is the reason why the outlet steam flow is larger than the inlet steam flow and thus the water balance can no longer be kept.

4.2 OTM reactor startup transient

A transient simulation test was carried out for the membrane reactor model shown in Figure 5 with the OTM integrated into 3.5 mm OD tubes where one side of the membrane was exposed to air (total air flow 10kg/s), while the other side was exposed to exhaust/sweep gas (total gas flow 1kg/s). Design parameters for membrane tubes and size of reactor are easily set in the standard geometry parameter dialog from the CombiPlant library, Figure 10.

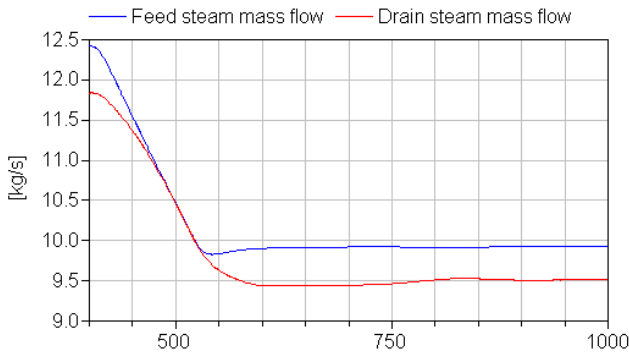

Figure 9: Mass flow of steam in the gas flow into and out of the Benfield plant section during load turn-down. Humidity control tries to match the flows to keep the plant water mass balance and avoid using make-up water.

Simulations show that a steady state condition is reached after approximately 3 hours, see Figure 11. BSCFO membrane material shows relatively short start up time compared to the SCFO materials which can take 500 hours until reaching steady state operating condition.

5 Final Remarks

The paper shows how the CombiPlant library, with components for standard combined cycle power plants, can be extended and used to build component and plant models for power plant concepts providing CO₂ emission free power. The library was used in a project with Siemens Industrial Turbomachinery to build a dynamic model of the Sargas power plant concept, which uses the commercial Benfield process to separate up to 95% of the CO₂ from the exhaust gases. In another application example, mass transfer through an oxygen transfer membrane has been described. This is a critical component in oxy-fuel combustion cycles such as AZEP.

References

[1] Sundkvist, S.G., T. Griffin, and N.P. Thorshaug, AZEP - Development of an integrated air separation membrane - gas turbine, In *Proceedings of Second Nordic Minisymposium on Carbon Dioxide Capture and Storage*, Gothenburg, Sweden, 2001.

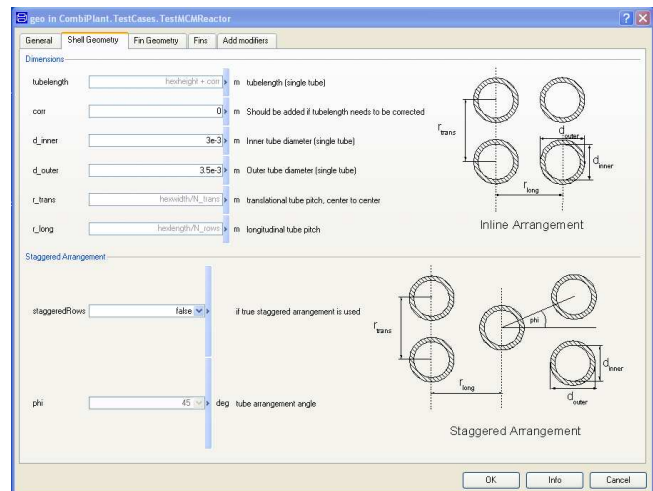

Figure 10: CombiPlant dialog for specifying heat exchanger geometry parameters. Friendly user interface provides help to input all required design parameters used in simulations.

- [2] Griffin, T., S.G. Sundkvist, K. Åsen, and T. Bruun, Advanced Zero Emissions Gas Turbine Power Plant, In *Proceedings of ASME Turbo Expo 2003*, Atlanta, USA, 2003.
- [3] Selimovic F., B. Sundén, M. Assadi, and A. Selimovic, Computational Analysis of an O₂ Separating Membrane for a CO₂-Emission-Free Power Process, In *Proceedings of Asme, IMECE2004-59382*, 2004.
- [4] Selimovic F., *Modeling of Transport Phenomena in Monolithic Structures Related to CO₂-Free Power Processes*. Licentiate Thesis, ISSN 0282-199, Department of Energy Sciences, Lund Institute of Technology, Sweden, 2005.
- [5] Casella, F., Object-Oriented Modelling of Two-phase Fluid Flows by the Finite Volume Method. In *Proceedings of 5th MATHMOD*, Vienna, Austria. Argesim, Vienna, February 2006.
- [6] Casella, F., M. Otter, K. Prölb, C. Richter and H. Tummescheit, The Modelica Fluid and Media library for modeling of incompressible and compressible thermo-fluid pipe networks. In *Proceedings of the 5th International Modelica Conference*, Vienna, Austria. Modelica Association, September 2006.
- [7] Tummescheit H., *Design and Implementation of Object-Oriented Model Libraries using Modelica*. PhD thesis ISRN LUTFD2/TFRT-1063-SE,

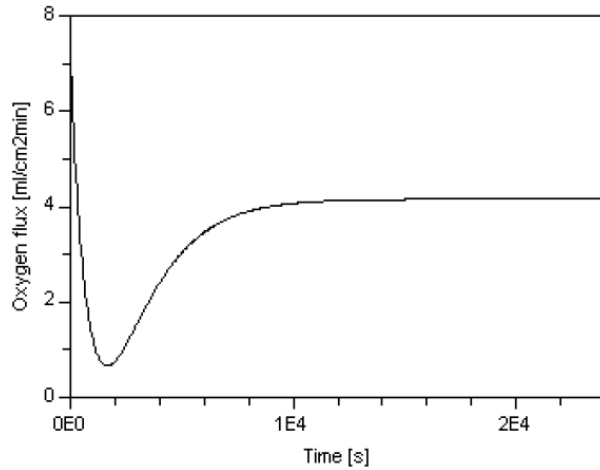

Figure 11: Oxygen permeation flux of the of the membrane reactor as a function of time.

Department of Automatic Control, Lund Institute of Technology, Sweden, August 2002.

- [8] Lu H., Y. Cong, and W.S. Yang, Oxygen permeability and stability of $\text{Ba}_{0.5}\text{Sr}_{0.5}\text{Co}_{0.8}\text{Fe}_{0.2}\text{O}_{2-d}$ as an oxygen permeable membrane at high pressures, *Solid State Ionics*, Vol.177, pp.595-600, 2006