

Faxitron X-Ray Corp.
Date Jan. 1, 1996

Models 43855A, 43855B, 43856A
Manual No. 5081-9519

TECHNICAL MANUAL

Faxitron Cabinet X-ray Systems
Models 43855A, 43855B and 43856A

CONTENTS	SECTION
General Information	1
Installation	2
Operation	3
Principles of Operation	4
Maintenance	5
Schematics	6
Part List	7
Radiation Survey	8
Maintenance Schedule	9

© Copyright Faxitron X-Ray Corporation 1983, 1984, 1986, 1987, 1989, 1990, 1994, 1996. This document contains or refers to proprietary information that is protected by copyright. All rights are reserved. Copying or other reproduction of this document is prohibited without the prior written permission of Faxitron X-Ray Corporation.

faxitron X-ray
CORPORATION
225 Larkin Drive
Wheeling, Illinois 60090-7209, USA
Telephone 847-465-9729 Fax 847-465-9740

REVISION RECORD

Rev.	From Serial No.	To (and incl.) Serial No.	Section and Revision									Date	
			1	2	3	4	5	6	7	8	9		
9	43855A: 43855B: 43856A:	43855A: 43855B: 43856A:	9	9	9	9	9	9	9	9	9	9	Jan 1, 1996
10	43855A: 43855B: 43856A:	43855A: 43855B: 43856A:											
11	43855A: 43855B: 43856A:	43855A: 43855B: 43856A:											
12	43855A: 43855B: 43856A:	43855A: 43855B: 43856A:											
13	43855A: 43855B: 43856A:	43855A: 43855B: 43856A:											
14	43855A: 43855B: 43856A:	43855A: 43855B: 43856A:											
15	43855A: 43855B: 43856A:	43855A: 43855B: 43856A:											
16	43855A: 43855B: 43856A:	43855A: 43855B: 43856A:											
17	43855A: 43855B: 43856A:	43855A: 43855B: 43856A:											
18	43855A: 43855B: 43856A:	43855A: 43855B: 43856A:											

MAINTENANCE WARNING

TO BE SERVICED BY QUALIFIED PERSONNEL ONLY

Serious injury (both physical and genetic) can result if all X-ray shielding is not properly replaced or interlocks are not operating after maintenance. Proper shielding replacement and interlock operation can only be confirmed by performing a radiation survey before placing the system in operation, and before use whenever the system is moved or serviced.

INSTALLATION WARNING

Faxitron X-Ray Corporation employees perform a radiation leakage survey during installation of your FAXITRON system. These persons are competent but may not be considered qualified experts. Check with your state radiation control authority to determine what the particular survey requirements are in your state. It might be required, that a qualified expert must survey the installation before placed in routine operation.

SAFETY SUMMARY

The following general safety precautions must be observed during all phases of operation, service, and repair of this system. Failure to comply with these precautions or with specific warnings elsewhere in this manual violates safety standards of design, manufacture and intended use of the system. Faxitron X-Ray Corporation assumes no liability for the customer's failure to comply with these requirements.

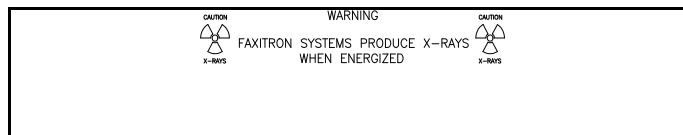

To ensure personnel safety, it is necessary that a radiation meter be used to check for radiation leakage during installation, after extensive maintenance, periodically (not to exceed six months), and after moving the system. The radiation meter must be a Victoreen Model 450 P or equivalent.

Geiger-Mueller and certain other scintillator-type radiation meters are not acceptable for checking radiation from Faxitron Systems.

Faxitron X-Ray Corporation Service Centers will perform this survey upon initial installation as well as provide operational checks and user instructions. This is an essential part of every sale in order to validate the system's warranty and ensure maximum radiation protection. The manufacturer considers the National Bureau of Standards Classification of Faxitron Systems a Protective Installation.

GOVERNMENT REGULATIONS

Certain states in the U.S. have radiation control regulations that require registration of radiation sources with cognizant state and/or local jurisdiction public health agencies. Registration normally must be made immediately or within 30 days of acquiring

each such source. Please telephone or write your state or local public health agency for registration information pertinent to this installation.

OPERATOR SAFETY

Faxitron Systems should be operated only by personnel who have been instructed in radiation safety and in operating instructions set forth in this manual. Each operator should read (as a minimum) sections 3 and 4 of the manual. In addition, Faxitron X-Ray Corporation recommends the use of a radiation film badge service for cumulative individual personnel monitoring. To obtain a film badge service and a radiation meter, contact the State Board of Health, a large hospital or an X-ray laboratory.

MOVING THE SYSTEM

It is permissible to move a Faxitron System after initial installation. However, due to possible mishandling, it is essential that a radiation survey be performed after any move to prevent hazards to personnel.

DO NOT OPERATE IN AN EXPLOSIVE ATMOSPHERE

Do not operate the system in the presence of flammable gases, fumes, or suspended dust particles. Fire or explosions could result because of ignition from electrical arcing.

GROUND THE SYSTEM

To minimize shock hazard, the system chassis and cabinet must be connected to an electrical ground. The instrument is equipped with a three-conductor AC power cable. The power cable must be plugged into an approved three-contact electrical outlet.

CHECK FOR PROPER WALL PLUG POLARITY

To retain optimum safety of the system in the event of improbable but possible electrical failures, it is important that the system be connected to a properly wired outlet. A properly wired outlet should give the following readings when checked with an AC voltmeter:

Neutral to Ground = 0 volts

Line to Ground = 120 volts

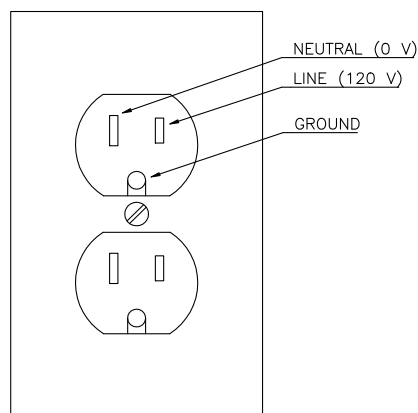

DO NOT SUBSTITUTE PARTS OR MODIFY SYSTEM

Because of the danger of introducing hazards, do not install substitute parts or perform any unauthorized modification to the system. Request assistance from a Faxitron X-Ray Corporation Sales and Service Office for service and repair to ensure that safety features are maintained.

KEEP AWAY FROM LIVE CIRCUITS

Operating personnel must not remove instrument covers. Component replacement and internal adjustments must be made by qualified maintenance personnel. Do not replace components with power cable connected.

DO NOT SERVICE OR ADJUST ALONE

Do not attempt internal service or adjustment unless another person, capable of rendering first aid and resuscitation, is present.

DANGEROUS PROCEDURE WARNINGS

Warnings, such as the example below, precede potentially dangerous procedures throughout this manual. Instructions contained

WARNING

During some maintenance procedures, dangerous radiation and high voltages, capable of causing death, are present in the system. Use extreme caution when handling, testing and adjusting.

in the warnings must be followed.



CAUTION

CARE SHOULD BE TAKEN WHEN OPERATING THIS MACHINE WHEN HIGH ELECTROSTATIC POTENTIALS ARE PRESENT. ELECTROSTATIC DISCHARGES MAY CAUSE LOSS OF FUNCTION AND/OR FILM ARTIFACTS TO OCCUR.

SECTION 1
GENERAL INFORMATION

CONTENTS	PAGE
1.1 Introduction.....	1.1
1.2 System and Manual Identification.....	1.1
1.3 Inquiries.....	1.1
1.4 System Description.....	1.2
1.5 Specifications	1.3
1.6 Radiation Tables.....	1.5

SECTION 1

GENERAL INFORMATION

1.1 INTRODUCTION.

Faxitron X-Ray Corporation Faxitron Models are self-contained, radiation-shielded cabinet X-ray systems designed to give high resolution radiographs of small to medium-size objects of all types. Simple operating techniques and radiation safety features made the Faxitron usually convenient in scientific and industrial X-ray inspection, quality control, reliability, and failure analysis or other operations requiring nondestructive testing techniques. High resolution by means of the microfocus options, also makes it very useful for medical pathology.

Each standard Faxitron system consists of a self-rectified X-ray generator with appropriate control circuitry mounted in a radiation-shielded cabinet, which has the shape of a small oven. The different models are available to accommodate various object sizes. The cabinet door is equipped with dual interlocks to prevent X-ray generation when the door is open. All cabinets and tables are designed to limit X-ray leakage to 0.5 mR/hour or less at 5 cm from any external surface. This meets the most recent recommendations by the National Bureau of Standards and the requirements of the Bureau of Radiological Health of the Department of Health and Human Services. Thus, they can be used in occupied areas with no additional X-ray shielding.

The self-rectifying thermionic X-ray tube is equipped with a beryllium window to allow a full spectrum of soft X-ray output. The standard X-ray tube has a 0.5 mm focus and is rated at 110 kV max. Options of 0.5 mm focus/ 130 kV, 0.07 mm focus/ 110 kV and 0.05 mm focus/ 55 kV are also available.

All Faxitron models are equipped with simple and convenient manual controls for selection of exposure time and X-ray tube kilovoltage.

The option A02 and A02M features automatic exposure control, in addition to the standard manual controls. The automatic exposure control helps the operator to select the optimum kVp and determine correct exposure time. An ionization chamber (exposure sensor) under the film shelf, monitors the X-rays penetrating the object and reaching the film, and terminates the X-ray when the proper exposure has been achieved. With the automatic exposure control, good pictures are more consistently obtained by inexperienced operators.

This manual contains installation and operating instructions, as well as maintenance information, system specifications, applications information and procedures for verifying proper operation. Preventive maintenance instructions, schematic diagrams, principles of operation, and troubleshooting information are provided for use in maintaining the system. The different models covered in this manual, are basically the same, except for minor differences which are noted within the text and on illustrations.

1.2 SYSTEM AND MANUAL IDENTIFICATION.

System identification by model and serial number is located on the lower right hand corner of the cabinet below the door (refer to Figure 1-3). Faxitron X-Ray Corporation uses a two-section serial number consisting of a four-digit prefix and a five-digit suffix, separated by a letter designating the country in which the instrument was manufactured. (A - U.S.A.; G = Germany; J = Japan; U = United Kingdom).

If changes have been made in the systems since this manual was printed, a "Manual Changes" supplement supplied with the manual will define these changes. Be sure to record these changes in your manual.

1.3 INQUIRIES.

Refer any questions regarding the manual or the Faxitron system to the nearest Faxitron X-Ray Corporation Sales/Service Office. Always identify system by model number and complete serial number in all communication.

In addition to the radiographic information contained in this manual, the following publication may be obtained from Eastman Kodak Company. "Radiography in Modern Industry" (4th Edition) provides much of the basic information on radiographic techniques.

1.4 SYSTEM DESCRIPTION

43855A Faxitron Single Cabinet X-Ray Systems; 64 cm maximum focal distance 10 - 110 kV output voltage; 3 mA continuous current, beryllium window (0.76 mm) X-ray tube; lead-shielded single cabinet; safety interlocks; 117 V, 60 Hz operation.

43855B Faxitron Dual Cabinet X-Ray Systems; 125 cm maximum focal distance 10 - 110 kV output voltage; 3 mA continuous current, beryllium window (0.76 mm) X-ray tube; lead-shielded single cabinet; safety interlocks; 117 V, 60 Hz operation

43856A Faxitron Cabinet / Table X-Ray Systems; 91 cm maximum focal distance 10 - 110 kV output voltage; 3 mA continuous current, beryllium window (0.76 mm) X-ray tube; lead-shielded single cabinet; safety interlocks; 117 V, 60 Hz operation



Fig. 1.1 The Models Covered in this Manual

OPTIONS

A02 Automatic exposure control and beam locator. Regulates exposures based on absorbed dose rather than time. Film densities can be repeatably achieved through the use of the ACE sensor which is placed under the film cassette or envelope. Compatible with A04 and standard X-ray sources.

A02M Automatic exposure control and beam locator. Used with M110 microfocus X-ray source.

A03 Isolation Line Adapting Transformer. This transformer has taps for 100, 190, 210, 230 and 250 V, 50 or 60 Hz. It is used to connect any of the Faxitron X-ray Systems to line voltages other than the standard 117 V, 60 Hz.

A04 10 - 130 kVp X-ray source; 3 mA tube current; beryllium window tube with 0.5 mm focal spot size. Recommended for thicker and/or denser samples.

M55 Microfocus X-ray tube with 0.05 mm focal spot size; 0.3 mA tube current; beryllium window; 55 kVp max.

M110 Microfocus X-ray tube with 0.07 mm focal spot size; 0.3 mA tube current; beryllium window; 110 kVp max.

A15 Fluoroscopic viewing screen; Incorporates a fluorescent screen and mirror assembly into the cabinet allowing operators an immediate view inside their samples without processing film. Primarily used for detecting the presence or absence of internal features when a permanent image is not needed.

1.5 SPECIFICATIONS.

RADIATION SAFETY

Radiation shielded cabinet.

Compartment door equipped with dual safety interlocks - each compartment door and drawer on dual cabinet and table systems.

Radiation: Less than 0.5 mR/hr at 5 cm (2 in.) from exterior surface at maximum kV.

Certified to comply with standards set by the US Food and Drug Administration, Center for Devices and Radiological Health, (21 CFR-1020.40).

Classified by Underwriters Laboratory in the US and Canada.

X-RAY TUBE

	Standard	Option A04	Option M110	Option M55
Focal spot size	0.5 mm	0.5 mm	0.07 mm	0.05 mm
kV	10-110	10-130	10-110	10-55
mA	3	3	0.3	0.3
Beryllium window thickness	0.76 mm	0.76 mm	0.76 mm	0.76 mm
X-ray beam divergence	30 deg.	30 deg.	30 deg.	30 deg.

BEAM COVERAGE (BC) AND SOURCE TO IMAGE DISTANCE (SID)

Model	43855A	43855B	43856A
Max. BC cm	21 x 26	39 x 45	30 x 36
SID cm			
Shelf Position 1	32	32	32
Shelf Position 2	46	46	46
Shelf Position 3	56	56	56
Bottom	61 max	61	61
Shelf Position 4		93	
Shelf Position 5		107	
Shelf Position 6		117	
Bottom		122 max	91 max

- Note:
- a. Radiation intensity exhibits normal "heel" effect, typical charts available upon request.
 - b. When using options A02 or A02M, the maximum SID is reduced by about 4 cm.
 - c. If unit is equipped with extension collar, add 15 cm to SID. Max BC will also increase.

EXPOSURE CONTROL

Standard: Manual timer with crystal controlled clock.
5 sec to 60 minutes (one second increments).

Option A02: Automatic and manual.

EXTERIOR DIMENSIONS (Approximate)

Model	43855A	43855B	43856A
Height mm (in.) *	889 (35)	1473 (58)	1803 (71)
Width mm (in.)	559 (22)	559 (22)	1727 (68)
Depth mm (in)	508 (20)	508 (20)	1143 (48)

* If the unit is equipped with an extension collar, add 153 mm (6 in.)

SPECIFICATIONS (cont'd)

COMPARTMENT INTERIOR DIMENSIONS (Approximate)

Model	43855A	43855B	43856A
Height mm (in.)	368 (14.5)	889 (35)	152 (6)
Width mm (in.)	457 (18)	457 (18)	1143 (45)
Depth mm (in)	394 (15.5)	394 (15.5)	1143 (45)

WEIGHT (Approximate)

Model	43855A	43855B	43856A
Net kg (lbs)	200 (440)	347 (765)	726 (1600)
Shipping kg (lbs)	227 (500)	386 (851)	771 (1700)

POWER REQUIREMENTS

Standard: 117 VAC \pm 10%, 60 Hz, 600 VA.

Option A03: Input taps for 100, 190, 210, 230 or 250 VAC \pm 6%, 50/60 Hz, 600 VA.

1.6 RADIATION TABLES

MATERIAL	DOSE-R
Silicon semiconductor*	7×10^6
Germanium semiconductor*	5×10^4
Capacitor	$3-7 \times 10^8$
Resistor	$2-5 \times 10^8$
Plastics	2×10^4
Ceramic, glass, optical	2×10^4
Explosives	1×10^8
Elastomeric materials	1×10^5
* Packages normally filter at least some of the radiation from reaching the chip.	

Table 1.1 Radiation Damage Thresholds
(For Reference)

TUBE VOLTAGE kVp	DISTANCE FROM ANODE (CM.)	APPROXIMATE DOSE R/MINUTE	FILTRATION (mm)	MEASURING INSTRUMENT
110	30.5	300	NONE	Victoreen 70/121 †
110	30.5	610	NONE	Victoreen 70/561 ††
110	63.5	70	NONE	Victoreen 70/131
110	*	51,000	NONE	Victoreen 70/651
130	30.5	400	NONE	Victoreen 70/131
130	30.5	10	0.36 Cu	Victoreen 70/131
* At Window † Response to 30 kev †† Response to 6 kev				

Table 1.2 Typical Radiation Output

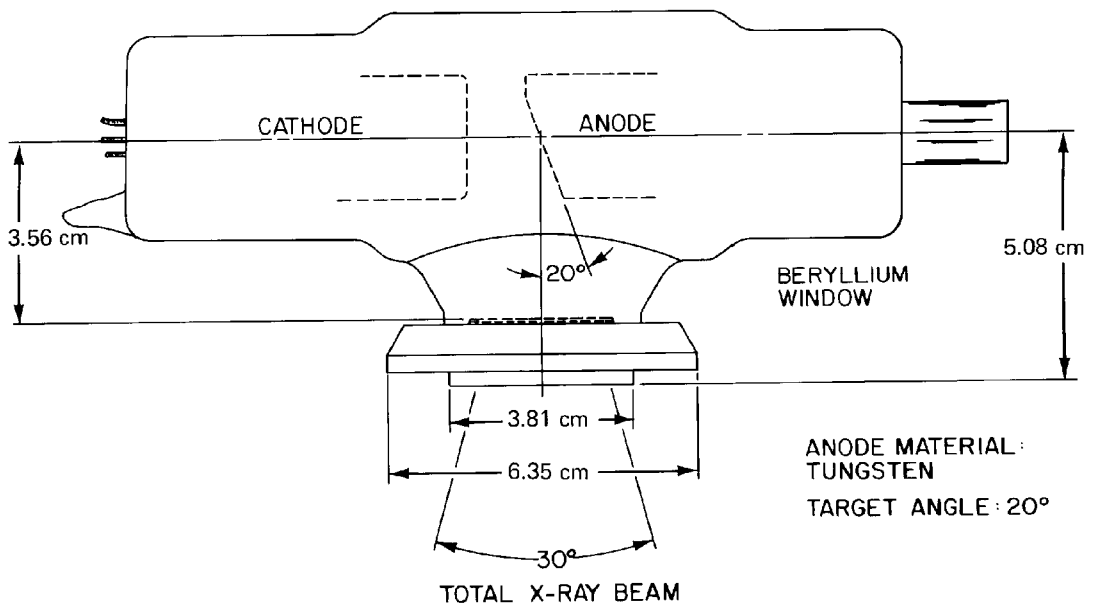

Figure 1-2. Outline Drawing of Faxitron Standard X-ray Tube.

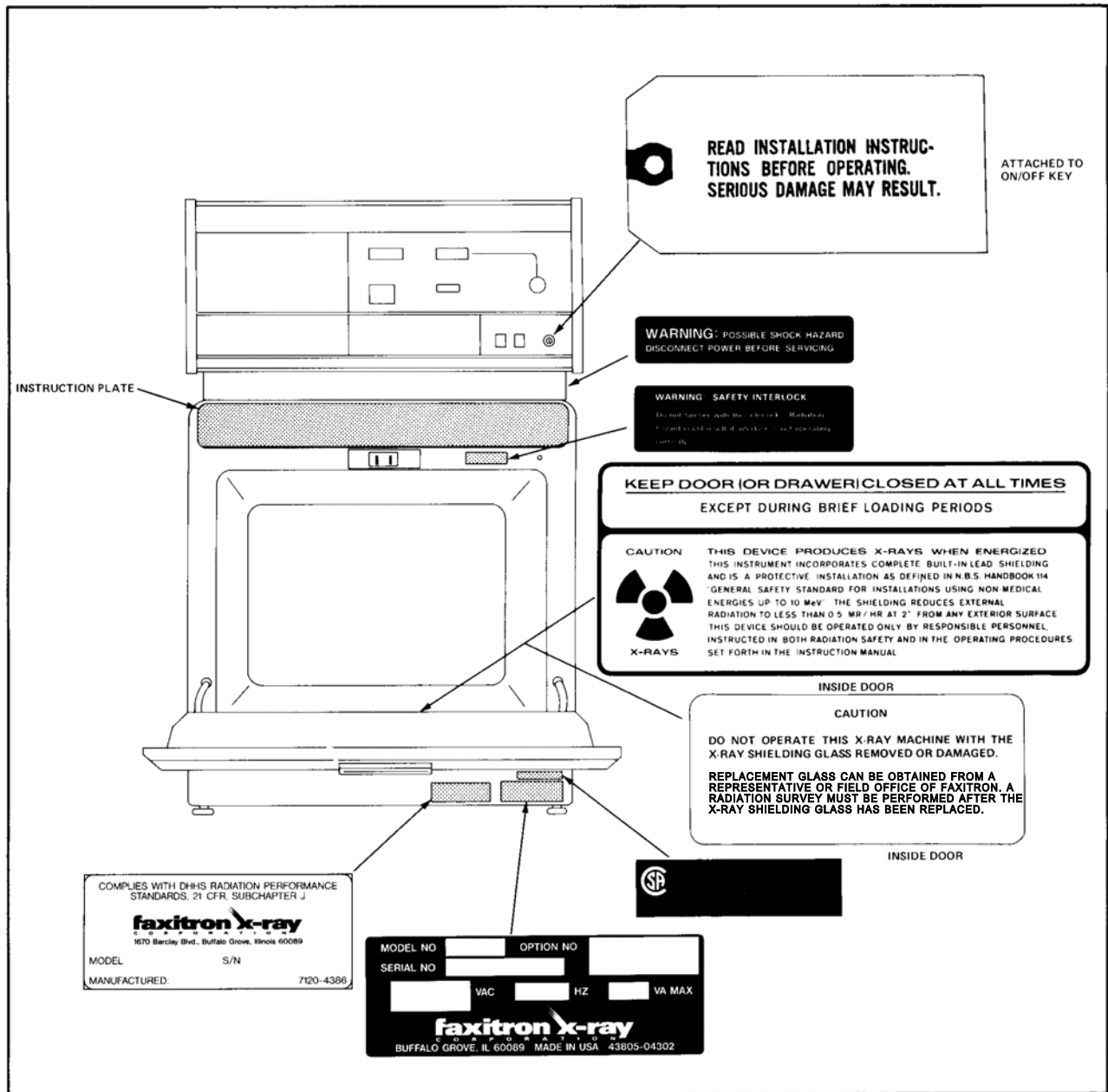
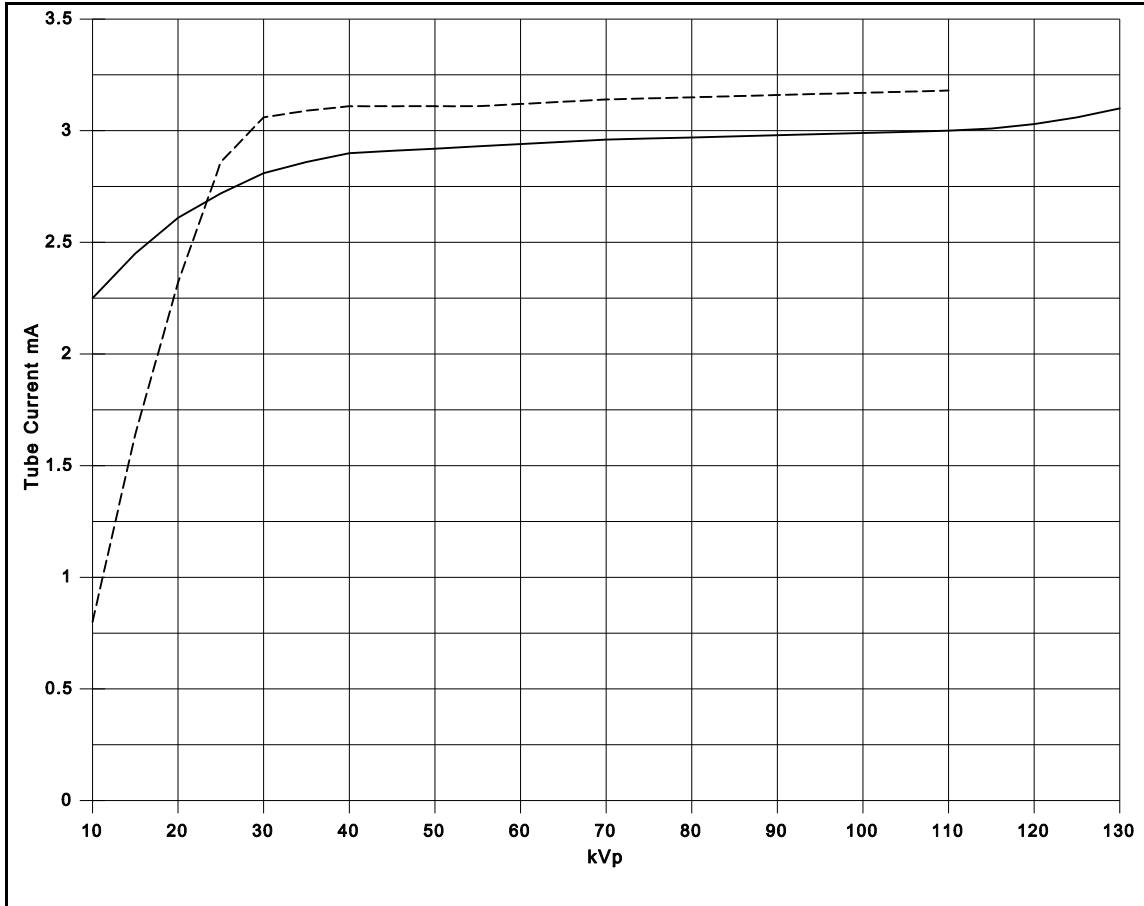

Figure 1-3. Location of Decals and Labels.

REGULATOR ADJUSTED AT 118 VAC PER I NSTRUCTI ON MANUAL



LI NE VOLTAGE OF 105 TO 130 VOLTS*

- Standard and Option A04 X-ray Tube
- - - - Options M55 and M110 Microfocus X-ray Tube, Tube Current = mA x 0.1

*Note: While the tube Current Regulation will conform to the curve shown above over the power line voltage range of 105 to 130 volts, the tube kVp will not reach rated maximum below 118 volts.

Figure 1-4. X-ray Tube Current Regulation Characteristics.

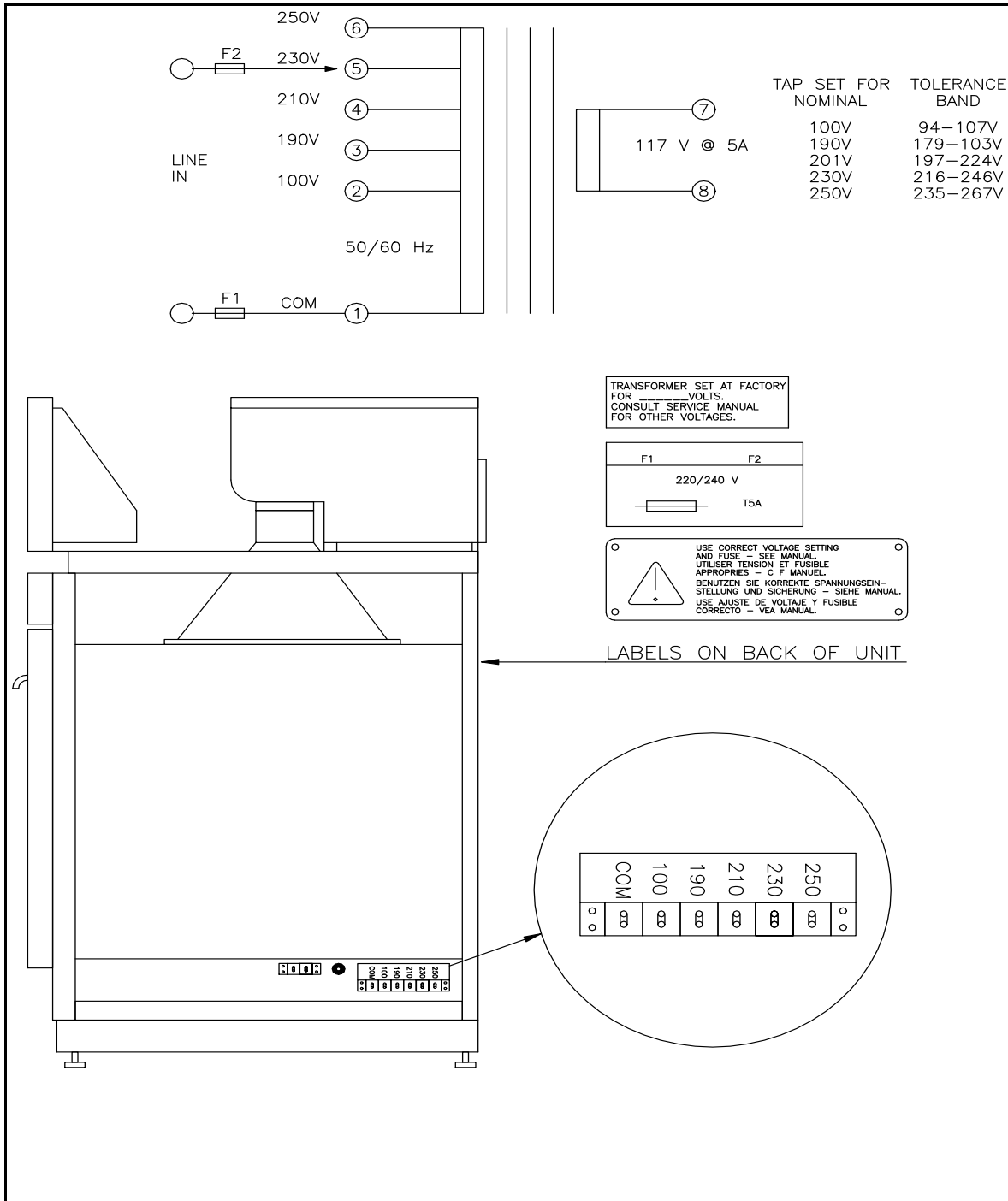

SECTION 2
INSTALLATION

CONTENTS	PAGE
2.1 Introduction.....	2.1
2.2 Initial Inspection.....	2.1
2.3 Preparation.....	2.1
2.4 Installation of Single Cabinet System 43855A.....	2.1
2.5 Installation of Dual Cabinet System 43855B.....	2.2
2.6 Installation of Table System 43856A.....	2.3
2.7 Installation of Fluoroscopy Option A15.....	2.5
2.8 Three Conductor AC Power Cable.....	2.6
2.9 Improperly Wired AC Outlets.....	2.6
2.10 Power Requirements.....	2.6
2.11 Operational Checkout and Radiation Survey.....	2.6
2.12 Claims.....	2.8

SECTION 2 INSTALLATION

2.1 INTRODUCTION.

This section contains information and instructions necessary for installing Faxitron Models Cabinet X-ray Systems. Included are initial inspection procedures, power and grounding requirements, environmental information, installation procedures and instructions for repackaging for shipment.

2.2 INITIAL INSPECTION.

Each Faxitron system is carefully inspected both mechanically and electrically before shipment. It should be free from scratches and in perfect operating order upon receipt. To confirm this, the system should be inspected for physical damage incurred in transit. If damage is found, refer to the claims paragraph in this section. Retain the packing material for possible future use.

2.3 PREPARATION.

All three systems are heavy and must be handled with care to prevent injury to personnel and/or damage to the equipment. The single cabinet system has a shipping weight of 227 kg (500 lbs), the dual cabinet system is 386 kg (851 lbs) and the table system is 771 kg (1700 lbs). For the dual cabinet system, which is top heavy, see special warning below.

WARNING

Read the Safety Summary at the front of this manual before installing or operating the system.

NOTE. In the Continental United States, Hawaii, Alaska, Canada and certain European Countries, you can get assistance with installation from an FXC field engineer by contacting the nearest Faxitron X-Ray Corporation Sales/Service Office. The field engineer will also perform or arrange for a radiation safety survey, and he will assist in training customer personnel in proper operation and use of the system.

2.4 INSTALLATION OF SINGLE CABINET SYSTEM 43855A.

1. Remove the top and side panels of the crate.
2. Unbolt the system from the shipping pallet.
3. Carefully remove the sheet metal top then the metal side panels from the cabinet. Each panel can be removed by loosening the screws at the top rear of each panel and then sliding the panel back to free it from the retaining lip at the front of the cabinet. The unit (200 kg or 440 lbs) can now be removed from the shipping pallet by one of the following techniques.
 - a. If a hoist is available, a sling going UNDER the cabinet, should be used to lift the unit off the shipping pallet.
 - b. If a hoist is not available, four or five people can lift the system. Again, lifting should be done ONLY from the frame of the cabinet.

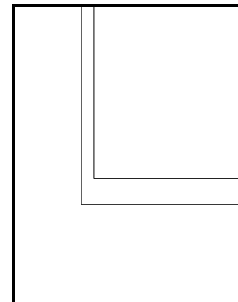

Installation of Single Cabinet System 43855A (cont'd)

4. When the system is unloaded from the shipping pallet, it can be moved with a refrigerator type moving cart, available from U-Haul, retail dealers or an appliance store. The side of the cabinet should rest against the cart frame and a strap should be used to hold the system to the cart. The strap should be placed around the frame and above the door. DO NOT place the strap over the door as this could mechanically warp the door mounting hinges. With the system secured to the cart, carefully move it to the area where it will be installed.
5. Using one of the procedures outlined in 3a or 3b, place the system on a sturdy, leveled table or bench. In areas where earth quake regulations are in effect, follow federal and local regulations to secure the system.

2.5 INSTALLATION OF DUAL CABINET SYSTEM 43855B.

WARNING

Model 43855B is top-heavy. For safety of operating and service personnel, the system must be bolted to the floor. Also please note that the weight of the system uncrated is 347 kg (765 lbs).

2. Unbolt the system from the shipping pallet.
3. Carefully remove the sheet metal top and then the metal side panels from both cabinets. Each panel can be removed by loosening the screws at the top rear of each panel and then sliding the panel back to free it from the retaining lip at the front of the cabinet. The unit (347 kg or 765 lbs) can now be removed from the shipping pallet by one of the following techniques.
 - a. If a hoist is available, a sling going UNDER the lower cabinet, should be used to lift the unit off the shipping pallet.
 - b. If a hoist is not available, six or seven people can lift the system, using one or two of the people to steady the system since it is top-heavy. Again, lifting should be done ONLY from the frame of the lower cabinet.
4. When the system is unloaded from the shipping pallet, it can be moved with a refrigerator type moving cart, available from U-Haul, retail dealers or an appliance store. The side of the cabinet should rest against the cart frame and a strap should be used to hold the system to the cart. The strap should be placed around the frame between the doors of the two cabinets. DO NOT place the strap over the door as this could mechanically warp the door mounting hinges. With the system secured to the cart, carefully move it to the area where it will be installed.
5. Place the system on the floor where it is to be used. By turning the adjustable feet, make certain that it is leveled and stable on the floor. Two holes with a 3/16"-16 thread are available, located inside the bottom base frame, one on each side of the unit. Depending on the floor construction and the local requirements, choose a method of securing the unit to the floor which will satisfy the requirements. For older systems with an extension base, access to bolt-down holes is gained by removing the base front cover. In areas where earth quake regulations are in effect, follow federal and local regulations to secure the system.

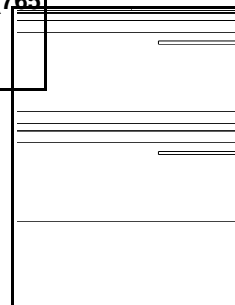

2.6 INSTALLATION OF TABLE SYSTEM WITH PULL-OUT DRAWER RADIATION CHAMBERS, MODEL 43856A.

The system is packed in two crates. The larger of the two crates contains the table, the smaller crate the cabinet. If possible, with a forklift, move the system while still in crates, as close as possible to where they are to be installed.

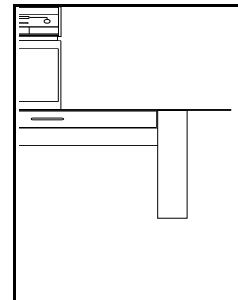

1. Remove the top and side panels of the large crate for the table.
2. The table can be lifted from the shipping pallet by using a hoist or eight strong people. The weight of the table is approximately 526 kg (1160 lbs). The table is normally not fastened to the shipping pallet.
3. Position the table where it is intended to be located. Avail it by adjusting the four leveling screws.
4. Remove the top and side panels of the crate for the cabinet.
5. Unbolt the unit from the shipping pallet.
6. Remove the four adjustable feet (one at each corner) from the bottom of the cabinet. The feet are threaded into the bottom frame.
7. Carefully remove the sheet metal top and then the metal side panels from the cabinet. Each panel can be removed by loosening the screws at the top rear of each panel and then sliding the panel back to free it from the retaining lip at the front of the cabinet. The unit (200 kg or 440 lbs) can now be removed from the shipping pallet by one of the following techniques.
 - a. If a hoist is available, a sling going UNDER the cabinet, should be used to lift the unit off the shipping pallet.
 - b. If a hoist is not available, four or five people can lift the system. Again, lifting should be done ONLY from the frame of the cabinet.
8. When the cabinet unit is unloaded from the shipping pallet, it can be moved with a refrigerator type moving cart, available from U-Haul, retail dealers or an appliance store. The side of the cabinet should rest against the cart frame and a strap should be used to hold the system to the cart. The strap should be placed around the frame and above the door. DO NOT place the strap over the door as this could mechanically warp the door mounting hinges. With the system secured to the cart, carefully move it to the area where it will be installed.
9. Using one of the procedures outlined in 7a or 7b, place the system on the already prepared steel table and align the two mounting holes with those on the table.

Installation of Table System (cont'd)

10. Route the interlock cables from the radiation table through holes in the table top and connect to the terminal boards TB1 and TB2 according to the wiring diagram in Figure 2-4.. If an automatic exposure control option A02 is included, the automatic exposure sensor cable must be properly connected. The filament voltage regulating transformer A2-T1, which normally is installed underneath the cabinet, now has to be installed under the table. The wires from this transformer have to be routed through the cabinet and

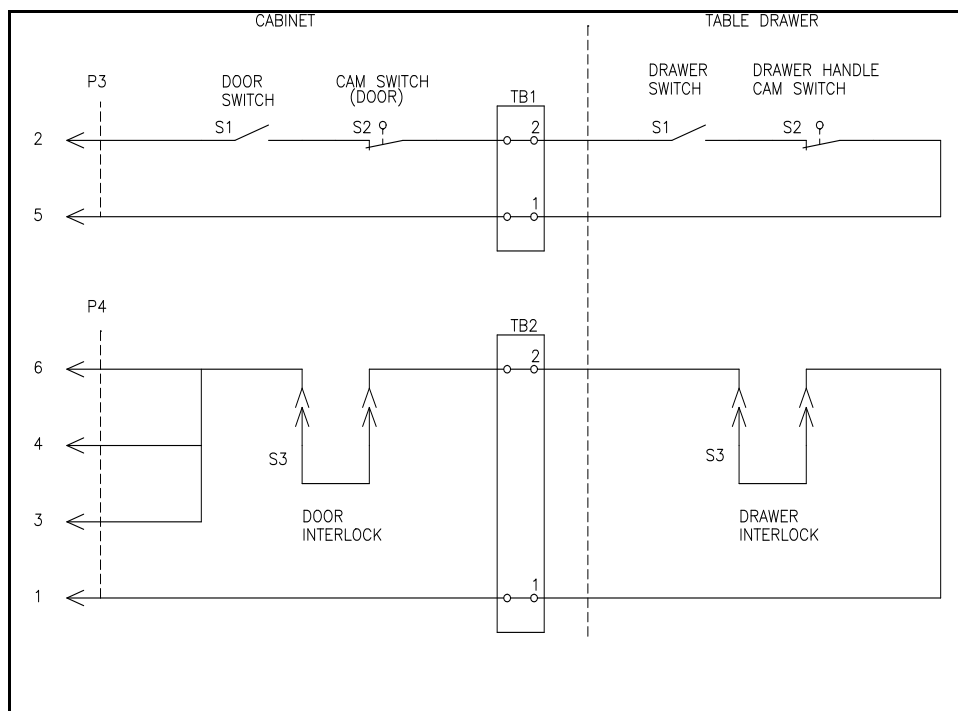

connected to flat blade lugs, J7, J9, J11, J12 and ground on the control board.

11. Position steel protective frame and lead collar in the opening between cabinet and radiation table.

12. Using two bolts provided, bolt cabinet to table. Make certain, the washers are positioned as shown in Figure 2-5. Bolts must be tight enough to provide electrical safety ground through the table and to the cabinet unit. Check resistance between table and cabinet. Resistance must not exceed 0.5 ohms.
13. Proceed with the operational checkout. When performing the interlock circuit check, be sure to check the table drawer interlock switches in addition to the cabinet door switches.

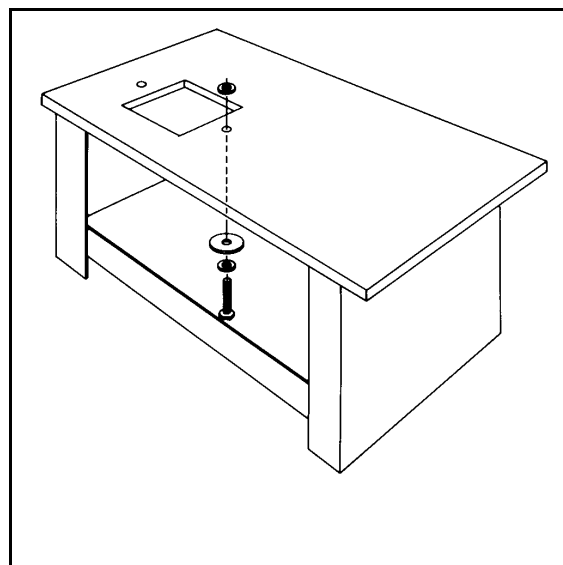

2.7 INSTALLATION OF FLUOROSCOPY OPTION, A15.

The fluoroscopy option provides direct viewing of the image by use of a lead-glass window in the door. A fluoroscopic screen and mirror are part of a shelf assembly (see Figure 2-6) which is placed on the middle shelf support inside the cabinet.

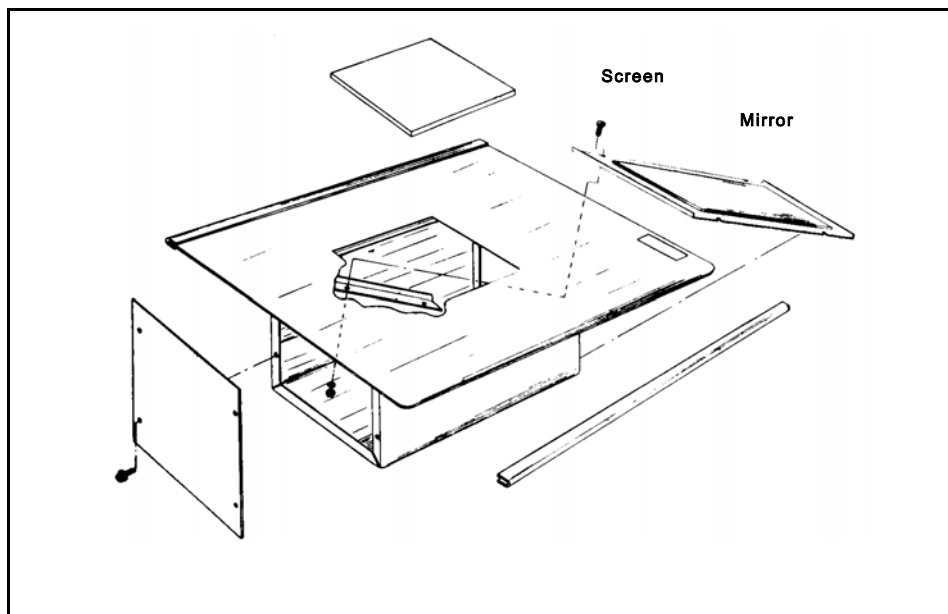

The maximum field of view is 20 cm x 25 cm (8" x 10"). In order to obtain the maximum view an optional 15 cm (6 inch) extension collar has to be used. With the fluoroscopy option, a 0.13 (0.005 inch) tungsten wire can be seen in a 12 mm (0.5 inch) aluminum block with the 110 kVp system. With film, a 0.025 mm (0.001 inch) wire can be seen in 100 mm (4 inches) of aluminum.

Parts of the fluoroscopy options are very delicate and must be handled accordingly. Warm water and soft tissue are recommended for cleaning the plastic -DO NOT USE SOLVENTS. When cleaning the X-ray shielded glass, exercise special care to prevent scratching. Avoid getting oil, fingerprints, etc., on the glass. The kit includes a fluorescent screen, a mirror and a lens. The fluorescent screen should not be stored in daylight or in any place where it is exposed to strong light. The mirror is very delicate and should be treated as such. A lens brush may be used to remove dust -DO NOT WIPE WITH CLOTH OR TISSUE. When not in use, the fluoroscopic shelf unit should be stored in a clean, dust-free container.

The installation of the fluoroscopy option is very simple when the option has been ordered with a new unit. The lead window is already installed in the door and the shelf unit is fully assembled. To use the fluoroscopy option, place the shelf assembly on the middle shelf support in the cabinet.

Proceed to the system performance test later in this section.

2.8 THREE-CONDUCTOR AC POWER CABLE.

For protection of operating personnel, Faxitron X-Ray Corporation requires that instrument panel and cabinet be grounded. The instrument is equipped with a three-conductor AC power cable that, when connected to an appropriate receptacle, grounds the instrument through the offset pin. Further, check to make certain the wall outlet is properly wired. See the following information about improperly wired ac outlets.

2.9 IMPROPERLY WIRED AC OUTLETS.

Two conditions can occur that will produce unusual readings on the kVp METER.

1. If the ground conductor is open, the kVp METER will indicate 10 to 20 kVp with the kVp CONTROL at the extreme counter-clockwise position. The kVp METER may indicate only 50 % of maximum kVp with the control set fully clockwise.
2. If the AC neutral and the AC hot conductors are reversed, the kVp METER will indicate maximum when the kVp CONTROL is in the counter-clockwise position. In other words, it acts as though the kVp CONTROL is working backwards.

2.10 POWER REQUIREMENTS.

As standard, all models require a power source of 117 V \pm 10%, 60 Hz, that can deliver 600 VA.

With option A03, transformer taps are available at 100, 190, 210, 230 and 250 V \pm 6%, 50 or 60 Hz, and the power consumption is still 600 VA.

For conditions where line voltages routinely fluctuate beyond the above tolerances, a sinusoidal voltage regulator is recommended.

2.11 OPERATIONAL CHECKOUT AND RADIATION SURVEY.

Install the Faxitron System and perform operational checkout and radiation survey (see Figure 2-8 and Section 8) as follows:

WARNING

A radiation meter (Victoreen Model 450 P or equivalent) is required for personnel safety during performance of this procedure. Make certain that the system has been installed securely. Model 43855A should be on a sturdy, leveled table or bench. Models 43855B should be bolted to the floor.

2. Verify that the exposure chamber door is completely closed and that the shelf is in the lowest position.
3. Move the SLIDING COVER **10** to the left to expose the mA ADJUST control **12**.
4. Verify that the CIRCUIT BREAKER **11** and the SAFETY LOCK SWITCH **3** are off.
5. Turn the kVp CONTROL **2** fully counter-clockwise.
6. Connect the power line cord to 117 volts 60 Hz AC. For instruments with the A03 option, adjust the transformer taps to match the line voltage. See Figure 1-5.
7. Place the CIRCUIT BREAKER **11** in the ON position.

Operational Checkout and Radiation Survey (cont'd)

8. Insert the key in the SAFETY LOCKSWITCH 3 and turn the switch ON. The kVp METER 1 digits should indicate 00 or 01.
9. Set the TIME SET thumbwheels 8 to 05 00.
10. Turn the kVp knob 2 clockwise until the kVp METER 1 indicates 30.

WARNING

The TUBE CURRENT METER (bar graph) 7 and Figure 2-7, is a direct indication that X-rays are being produced. When exposure is complete, the bar graph must blank out. If it does not indicate zero when the exposure is complete (time digits blank out), turn the kVp CONTROL to ZERO (full counter-clockwise), turn the SAFETY LOCK switch 3 to OFF and remove the key. Call your Faxitron X-Ray Corporation Sales/Service Office for assistance.

11. Press the X-RAY START switch 4 momentarily. The X-RAY ON light (which is part of the X-RAY START switch) will glow brightly and the TIME digits 9 will indicate 05.00 and begin counting down toward zero in one second steps. The TUBE CURRENT bar graph, Figure 2-7, should indicate between 2.5 and 3.0 mA (0.25 - 0.3 mA with the micro-focus X-ray tube).
12. The tube current can be adjusted by turning the mA ADJUST control 12. This control should be set for an indicated between 2.7 and 3.0 mA on the TUBE CURRENT bar graph (0.27 - 0.3 mA with micro-focus X-ray tube).
13. Check for radiation leakage. There should be no measurable X-ray leakage. Allow the system to complete the 5 minute cycle. The TIME DISPLAY digits and TUBE CURRENT bar graph will blank out at the end of the time cycle.
14. Set the kVp CONTROL 2 for 60 (55 with M55 micro-focus tube) on the kVp METER 1. Press X-ray start. The TUBE CURRENT bar graph 7 should indicate between 2.7 and 3.0 mA (0.27 - 0.3 mA with micro-focus X-ray tube). Repeat the radiation leakage test. Allow unit to complete the 5 minute cycle.
15. Depending on the X-ray tube used, repeat the step 14 at 90, 110 and 130 kVp, or until maximum kVp has been reached.
16. Open the EXPOSURE CHAMBER door. Place a shelf at the 18" SID level and a 4 liter (1 gallon) plastic jug of water on the center of the shelf. Check for radiation leakage at maximum kVp. Leakage should be less than 0.5 mR/hour at 5 cm (2 inches) from any external surface. (Refer to Section 8). Note that the UK limit for this test is 0.1 mR/hour.
17. Close the test point access panel 10.

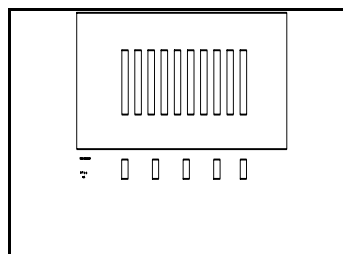

Operational Checkout and Radiation Survey (cont'd)

NOTE.

If the exposure is interrupted, the X-RAY ON lamp and the TUBE CURRENT bar graph will extinguish. The TIME DISPLAY digits will indicate the exposure time remaining to timed turn-off. To continue the exposure, set the TIME SET thumbwheels to the same number shown on the TIME DISPLAY digits and press X-RAY START.

18. Press the X-RAY START switch (X-RAY ON indicator will light). Slowly open the compartment door; X-RAY ON light should go off and TUBE CURRENT bar graph should indicate zero (blank out) when the door is open approximately 1.5 mm (0.060 inch). (Refer to Section 5 for interlock adjustment procedure). When closing the door again, the X-RAY ON light should **not** come on and the TUBE CURRENT bar graph should remain blanked out.
19. With the dual cabinet model, repeat step 18 on the second cabinet.
20. With the table model, also check that the X-RAY ON light will go off and that the TUBE CURRENT bar graph indicates zero (blank out) when the drawer handle is turned about 12 mm (½ inch) at the end. (Refer to Section 5 for adjustment procedure). With the handle turned in this position, make certain that the drawer can not be pulled out. When closing the handle again, the X-RAY ON light should **not** come on and the TUBE CURRENT bar graph should remain blanked out.
21. Block the door open to a point just prior to where the X-RAY ON light turns off and TUBE CURRENT turns off. (Use paper or wood blocks).
22. Again, check for radiation leakage at maximum kVp. Leakage should be less than 0.5 mR/hour at 5 cm (2 inches) from any external surface. (Refer to Section 8). Note that the UK limit for this test is 0.1 mR/hour. If radiation exceeds specified limits, further adjustment of interlock switches is necessary. Refer to section 5.
23. Fill out Faxitron Installation Report supplied with this manual and return the top copy to:

Faxitron X-Ray Corporation
Customer Service manager
225 Larkin Drive
Wheeling, Illinois 60090-7209, USA

Retain the bottom copy in the manual for permanent record.

2.12 CLAIMS.

The warranty statement applicable to the system is included after the title page of this manual. Save all packing material. If physical damage is found or if operation is not as specified when the instrument is received, notify the carrier and the nearest Faxitron X-Ray Corporation Sales/Service Office immediately (refer to the list in the back of this manual for addresses).

If reshipment is required, consult your nearest Faxitron X-Ray Sales/Service Office for assistance. If the original shipping crate is not available, use of padded van is recommended. After moving the system, a radiation survey and incoming inspection per the Maintenance Table in Section 9 is required.

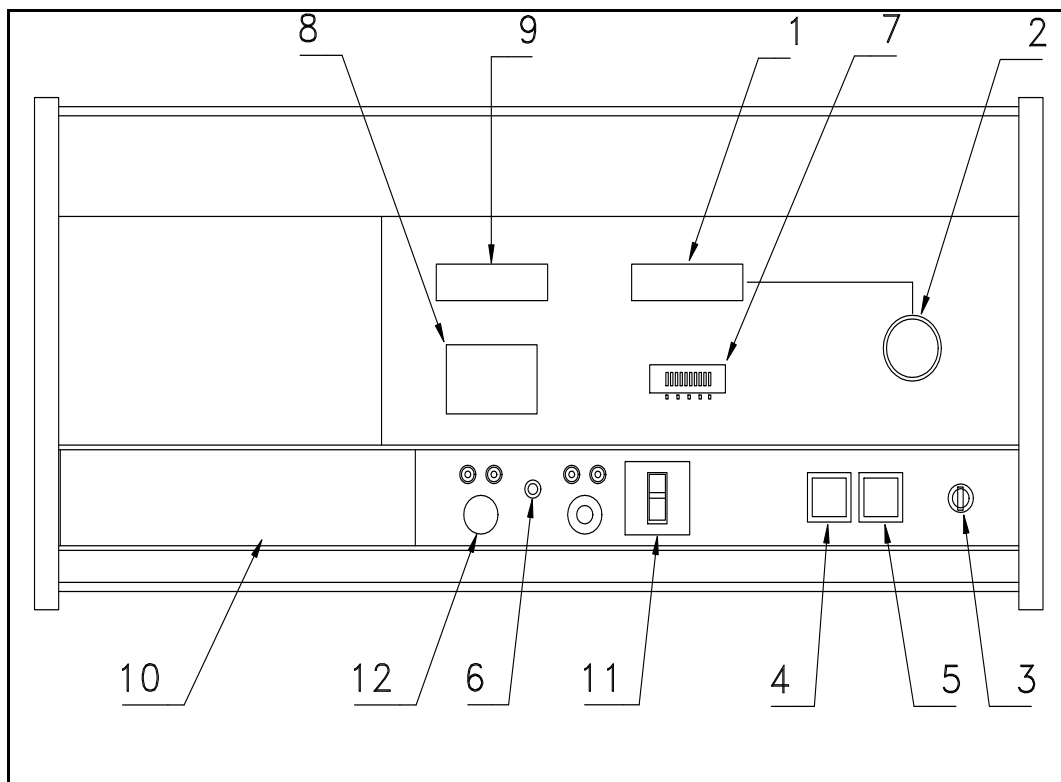

- 1 kVp METER
- 2 kVp CONTROL
- 3 SAFETY LOCK SWITCH
- 4 X-RAY START SWITCH with X-RAY ON light
- 5 X-RAY STOP SWITCH
- 6 OVER TEMPERATURE INDICATOR
- 7 TUBE CURRENT METER
- 8 TIME SET THUMBWHEELS
- 9 DIGITAL TIME DISPLAY
- 10 SLIDING COVER
- 11 CIRCUIT BREAKER
- 12 mA ADJUST

SECTION 3
OPERATION

CONTENTS	PAGE
3.1 Controls on Standard Unit with Manual Exposure Control.....	3.1
3.2 Controls on Unit with Automatic Exposure Control	3.3
3.3 Operating Considerations	3.5
3.4 Step-by-Step Operating Instructions, Manual Mode	3.6
3.5 Step-by-Step Operating Instructions, Automatic Exposure Control Mode	3.7
3.6 Applications Information	3.8
3.6.1 X-ray Damage - Radiographic Samples	3.8
3.6.2 Magnification	3.8
3.6.3 Geometrical Unsharpness.....	3.9
3.6.4 Scatter Radiation.....	3.10
3.6.5 Low kVp Operation.....	3.12
3.6.6 Positioning the Object - Automatic Exposure Control.....	3.13
3.6.7 Fluoroscopic Viewing	3.14

SECTION 3 OPERATION

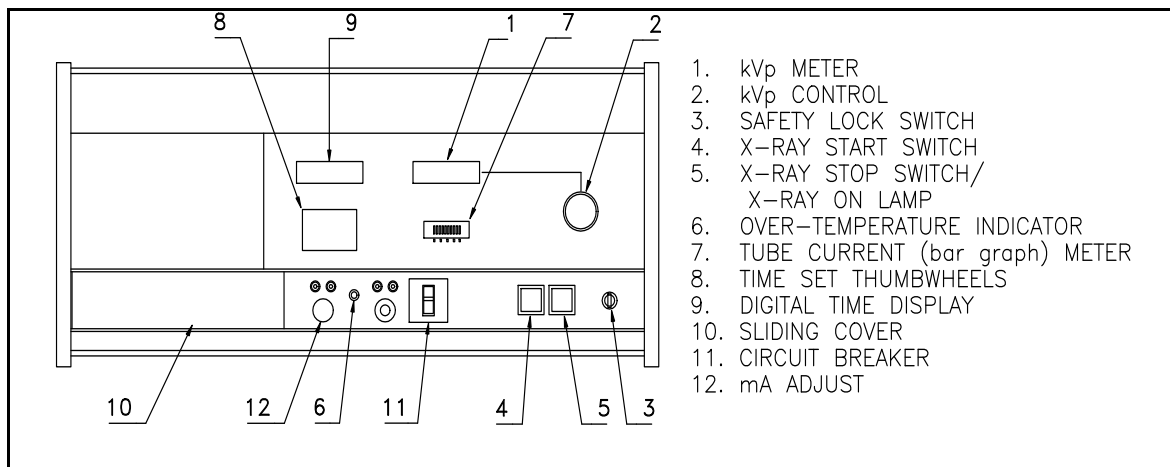

3.1 CONTROLS ON STANDARD UNIT WITH MANUAL EXPOSURE CONTROL, (see Figure 3-1).

1. kVp METER. This 2½ digit voltmeter indicates peak X-ray tube voltage in kilovolts (kVp). It is driven by the output of the kVp control variable transformer, but is calibrated to indicate secondary peak voltage of the high voltage transformer. The meter is calibrated to read 55 kVp, 110 kVp or 130 kVp at 118 VAC input. The maximum kVp depends on the X-ray tube used.
2. kVp CONTROL. This variable transformer allows the X-ray tube anode voltage to be continuously varied from zero up to the maximum for the X-ray tube.
3. SAFETY LOCK switch. This switch prevents unauthorized use of the X-ray equipment. This complies with UL and regulations set forth by the Bureau of Radiological Health, a division of Health and Human Services.
4. X-RAY START switch. When this switch is pressed, the main power relay closes energizing the X-ray tube high voltage transformer. The relay remains closed until the exposure is terminated by the timer, the automatic exposure circuit or by opening an interlock.
5. X-RAY STOP switch (includes the X-RAY ON indicator lamp). The X-ray on lamp lights whenever the power relay is closed and indirectly indicates X-ray generation. If this switch is pressed during an exposure, the lamp will extinguish and production of X-rays will cease.
6. OVER-TEMPERATURE indicator. This neon indicator is connected across the normally closed contacts of a thermal switch, located within the tube enclosure. In case of excessive heating, the switch will open, lighting the over-temperature lamp and removing all AC power except to the fan. The thermal switch opens at approximately 180 degrees F and ones open, has a 40 degree temperature differential
7. TUBE CURRENT bar graph meter. The bar graph is a set of ten closely spaced light emitting diodes (LED), which replaces an analog type meter. The TUBE CURRENT bar graph is a direct indicator of X-ray generation. Eight segments of the display equal 3.0 mA (0.3 mA if a micro-focus X-ray tube is used). If segment number 10 lights, it indicates an overcurrent condition. Segment number 9 is blanked out so that if an overcurrent condition exists, a definite break in the light bar will be visible.
8. Exposure TIME SET thumbwheel switches. In the manual (timed) mode of operation, the thumbwheels provide a method of pre-setting any exposure time from 1 second to 59 minutes, 59 seconds. Timing is

accomplished by a quartz crystal controlled electronic clock circuit.

Controls on Standard Unit (cont'd)

9. Digital TIME DISPLAY. A 4-digit display operating in conjunction with the TIME SET thumbwheels **8** make up the timer. The display is normally blanked out until the X-RAY START switch **4** is pressed. At this time, the TIME display lights and displays the numbers set up on the TIME SET thumbwheels. Countdown proceeds in one second increments until all digits read zero. At this time, exposure is terminated.

Note that if the exposure is interrupted, either by opening the door or pressing the STOP switch, the TIME display will indicate the remaining time. In order to finish the exposure, it will be necessary to reset the thumbwheel switches to agree with the number shown on the TIME display.

If the thumbwheel setting is not changed, the time will reset to that shown on the thumbwheels. The total exposure will consist of the partial, terminated exposure, in addition to that shown on the thumbwheels. This may cause overexposure of the X-ray film.

10. SLIDING COVER. Slide the cover to the left to expose the test points and controls beneath the cover.
11. CIRCUIT BREAKER. The circuit breaker protects the unit in case of component failure. For the unit to operate, the circuit breaker must be in the ON position.
12. mA ADJUST. This screwdriver adjust control allows adjustment of the maximum filament voltage which controls the X-ray tube current. The test points TP-1 and TP-2 allow a rapid check for malfunctions in the X-ray generator. Refer to the maintenance section of this manual.

Not illustrated above are the following items:

- a. EXPOSURE CHAMBER DOOR. The exposure chamber door has electrically independent interlocks which open before the door is open far enough to allow the escape of radiation. Opening either of these interlocks causes X-ray production to cease.
- b. X-RAY SHELF. By placing the shelf at different levels in the exposure chamber, different distances between the X-ray source and the film are obtained. The shelf is provided with centering lines and marks indicating centering for different sizes film cassettes..

WARNING

The TUBE CURRENT meter is a direct indication that X-rays are being produced. Hence, when the exposure is complete, TUBE CURRENT meter must indicate zero (bar graph blanked out). If TUBE CURRENT meter does not return to zero when the exposure cycle is completed, turn the POWER switch OFF, remove the key, and unplug the AC power cord. Notify your Faxitron X-Ray Corporation Sales/Service Regional or Local Office for assistance..

3.2 CONTROLS ON UNIT WITH AUTOMATIC EXPOSURE CONTROL (AEC), OPTION A02, (see Figure 3.2).

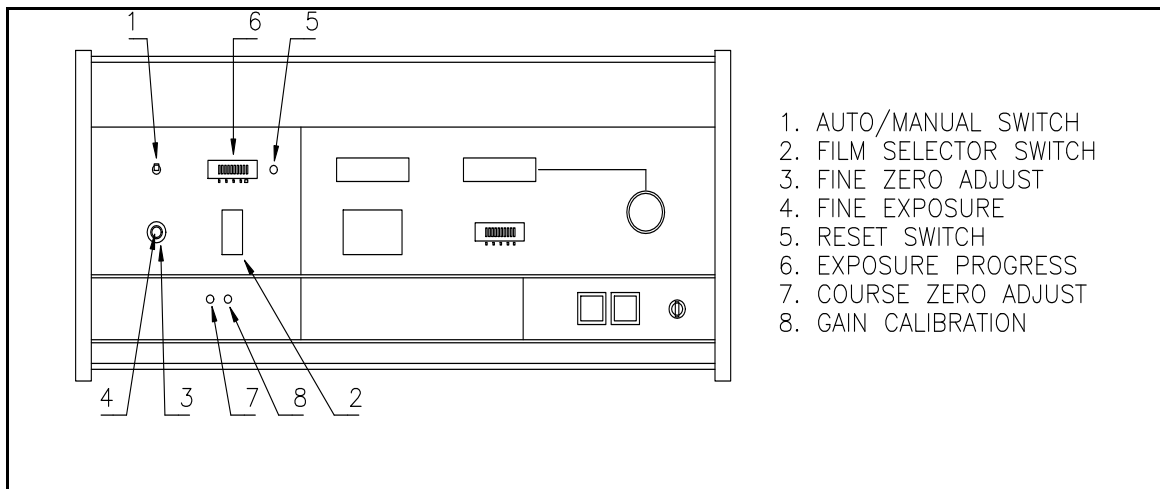

All controls and indicators previously described for the Manual Exposure Control, also apply to the AEC , option A02. In addition, a totally separate set of control and indicators, as shown in Figure 3-2, controls the AEC function. If the AEC option is to be used in the manual mode, all instructions for the standard model apply. The following information is for automatic use only.

1. AUTO/MANUAL switch selects the manual or automatic mode of operation.
2. FILM SELECTOR switch. This thumbwheel switch controls the gain of the auto exposure amplifier. Switch positions 0 through 5 provide a 32 to 1 range of amplification to accommodate a wide range of film sensitivities. See Table 3-1.
3. FINE ZERO adjust. This control is part of a concentrically mounted variable resistor assembly. This control allows for small variations due to changes in sensor characteristics.
4. FINE EXPOSURE control. This control provides a continuously variable gain adjustment when used in conjunction with the film switch. For films whose sensitivities may fall between the steps provided by the film switch, this control allows a smooth control of exposure. See Table 3-1.
5. RESET switch. This push button switch resets the amplifier circuit and energizes a solenoid within the sensor assembly. This recharges the sensor element.
6. EXPOSURE PROGRESS bar graph meter. This indicator serves a dual purpose. The primary function is to provide information of the amount of exposure remaining in any given time. The secondary function is a zero indicator for adjusting the automatic sensor. The bar graph also provides troubleshooting information in case of malfunction of the auto exposure system.
7. COARSE ZERO adjust. Each sensor presents a slightly different output voltage for a given set of power supply voltages. Since after reset, the sensor output should be zero volts, some adjustment is necessary. This front panel accessible trimmer varies the drain resistance of the sensor MOSFET to compensate for the various parameters of sensor and power supply voltages.
8. GAIN CALIBRATION. A front panel accessible trimmer is used to adjust the overall gain of the system. This control is used in conjunction with the calibration sample. Refer to the maintenance section of this manual for details.

Controls on Unit with Automatic Exposure Control (cont'd)

EXPOSURE INTERRUPTION, AUTOMATIC MODE ONLY.

If the exposure is accidentally interrupted by opening the door before the exposure is completed, proceed as follows:

- a. Close the door.
- b. Press X-RAY START switch.
- c. The exposure will continue from the point of interruption and the TIME DISPLAY will continue the count until automatic turn-off occurs.

SHELF WITH AEC OPTION.

The shelf used with the AEC option A02, has a small hole in the center. The X-ray sensor is mounted below the hole on the bottom surface of the shelf. To facilitate removal of the shelf and the X-ray sensor, the sensor has a connector located in the lower right corner of the exposure chamber.

BEAM LOCATOR.

A beam locator is included in the AEC option A02. It is attached to the upper surface of the exposure chamber. This device pivots, allowing it to be positioned over the sensor. A "V" shaped image of a lamp filament is projected through a lens system to indicate the location of the sensor. This makes it possible to know the sensor location when it is covered by X-ray film and the subject to be radiographed. This allows the subject to be positioned so that the area of interest is directly over the sensor.

The beam locator lamp is automatically turned on when the lamp assembly is positioned over the sensor.

3.3 OPERATING CONSIDERATIONS.

1. General.

Faxitron Shielded Cabinet Systems combine applications versatility and office machine simplicity so that personnel can X-ray, research and production objects with convenience in their own laboratory. Automatic exposure control (Option A02) provides high quality radiographs (X-ray photographs), usually on the first try over wide ranges of film speeds (32:1) and voltages (10-130 kVp), both of which are required for versatile radiography. An X-ray film selection guide with corresponding control settings, developing time, etc., is provided in Table 3-1.

2. Radiation Protection.

Faxitron Shielded Cabinet X-ray Systems have been designed to conform to the standards for cabinet X-ray systems as specified by US Food and Drug Administration, Center for Devices and Radiological Health, (21 CFR-1020.40). A certification decal along with the date of manufacture is placed on each system.

Each system is checked prior to shipment to ensure that radiation leakage is below 0.5 mR/hr (0.1 mR/hr for systems shipped to UK) at 5 cm from any external surface. Further, Faxitron X-Ray Corporation requires units to be checked for leakage upon installation.

In order to assure proper performance and safety of the system, the schedule in the maintenance section of this manual must be followed. In addition, portions of this schedule must be performed after maintenance and after system relocation.

Do not operate system above the maximum kVp indication on the kVp METER (i.e., 110 kVp for standard systems, 55 kVp for option M55 and 130 kVp for option A04).

Internal lead shielding reduces external radiation and safety interlock switches minimize the possibility of exposure if the compartment door is not completely closed. Radiation is shut off when the door opens. Restart is not possible until the door is closed and the X-RAY START button is pressed again.

3. Safety Considerations.

The following steps will minimize the possible risks that undetected radiation might create for you and other personnel:

- a. Turn the kVp CONTROL to zero immediately after each exposure and leave it there between exposures.
- b. Keep the compartment door closed at all times except during brief loading periods.
- c. Turn POWER switch to OFF position whenever the system is not going to be used for an extended period (approximately ten minutes or more).
- d. Always monitor the X-RAY ON and TUBE CURRENT meter to be certain the light is off and the bar graph meter is at zero (blanked out) after each exposure.
- e. A radiation survey should be performed, by competent personnel, every six months and when unit is moved or serviced. Proper calibrated instrument should be used.

4. Increasing X-ray Tube Life.

A preliminary one to two minute exposure, below 70 kVp, will lengthen the life of the X-ray tube if the systems AC power has been off overnight. If the first exposure is to be made below 70 kVp, the preliminary exposure is not necessary.

WARNING

Faxitron systems produce X-rays when energized. They should be operated only by personnel who have received proper instructions in radiation safety and in the correct use of the equipment. Read the Safety Summary in front of this manual before attempting to operate the equipment.

The TUBE CURRENT bar graph meter is a direct indication that X-rays are being produced. Hence, when exposure is complete, TUBE CURRENT meter must indicate zero (bar graph blanked out). If TUBE CURRENT meter does not return to zero when the exposure cycle is completed, turn the POWER switch to OFF, remove the key, and unplug the AC power cord. Notify your Faxitron X-Ray Corporation Sales/Service Regional or Local Office for assistance.

3.4 STEP-BY-STEP OPERATING INSTRUCTIONS, MANUAL MODE.

To operate the Faxitron systems (including the AEC option A02) in manual mode, perform the following steps:

1. Verify that compartment door is closed.
2. Insert key in POWER switch and turn to ON position; the digital kVp meter will light.
3. With AEC option A02, set AUTO/MANUAL switch to MANUAL.
4. Turn kVp CONTROL fully counterclockwise and verify that TUBE CURRENT bar graph meter indicates zero. Verify that the X-RAY ON light is off. Open compartment door and place film on shelf.
5. Place object on film and position it for best radiographic view.
6. Close compartment door completely.
7. Adjust kVp CONTROL for desired value on kVp METER.
8. Set TIME SET thumbwheels to desired exposure duration (up to 59 minutes, 59 seconds).
9. Press X-RAY START switch. X-RAY ON light and TUBE CURRENT bar graph meter indicates that exposure is in progress. The TIME DISPLAY will light and indicate the number on the TIME SET thumbwheels. The display will count down in one second steps until it reaches zero. At this point, the display will blank out and the exposure will terminate.
10. When X-RAY ON light goes off and TUBE CURRENT meter drops to zero, exposure is complete.
11. Turn kVp CONTROL fully counterclockwise and verify that TUBE CURRENT meter indicates zero.
12. Open compartment door and remove specimen and film.
13. Close compartment door.
14. Process film in normal manner.

Note that if the exposure is interrupted, either by opening the door or pressing the STOP switch, the TIME display will indicate the remaining time. In order to finish the exposure, it will be necessary to reset the thumbwheel switches to agree with the number shown on the TIME display.

If the thumbwheel setting is not changed, the time will reset to that shown on the thumbwheels. The total exposure will consist of the partial, terminated exposure, in addition to that shown on the thumbwheels. This may cause overexposure of the X-ray film.

3.5 STEP-BY-STEP OPERATING INSTRUCTIONS, AUTOMATIC EXPOSURE CONTROL MODE (OPTION A02).

To operate the Faxitron systems with AEC Option A02 in AUTO mode, perform the following steps:

1. Verify that compartment door is closed.
2. Insert key in POWER switch and turn to ON position; the digital kVp meter will light.
3. With AEC option A02, set AUTO/MANUAL switch to AUTO.
4. Turn kVp CONTROL fully counterclockwise and verify that TUBE CURRENT bar graph meter and the kVp METER indicates zero. Verify that the X-RAY ON light is off.
5. Open compartment door and place film support shelf, with the AEC sensor attached to the underside of it, at the desired level.
6. Insert sensor cable plug into jack located inside cabinet at lower right-hand corner.
7. Place film on shelf and center it using the centerlines for different size film as a guide.
8. Swing beam locator out. Light beam will locate center of exposure sensor. With the light beam as a guide, position the object on the film in such a way, as to obtain the best radiographic view.
9. Close compartment door completely.
10. Turn FILM SELECTOR switch to proper number and set FINE EXPOSURE control for type of film being used (see Table 3-1).
11. Press RESET switch. Verify that both the EXPOSURE PROGRESS meter and the TIME DISPLAY indicate zero. If necessary, EXPOSURE PROGRESS meter (bar graph) may be zeroed by turning the FINE ZERO adjust knob.
12. Press X-RAY START switch. X-RAY ON light and TUBE CURRENT bar graph meter indicates that exposure is in progress. The TIME DISPLAY will start at zero and count up in one second increments until exposure is complete. The display will then hold the reading until the X-RAY ON switch is pressed the next time or until the unit is turned off.

Note. In AUTO mode operation, if the door is accidentally opened before the exposure is completed, radiation will cease and the X-RAY ON light will go off. The exposure can be continued by closing the door and pressing the X-RAY START switch. To intentionally stop the exposure, press the X-RAY STOP switch.

13. Slowly turn kVp CONTROL knob while watching EXPOSURE PROGRESS meter until the light begins to transfer to the next segment. Leave kVp CONTROL at that setting until exposure is complete.

Note. The rate at which the EXPOSURE PROGRESS meter (bar graph) moves is an indication of the proper kVp and whether the film type is adequate for the specimen being radiographed. Strive for kVp CONTROL settings and film types which result in exposure times from one-half to five minutes.

14. When film is properly exposed, X-RAY ON light goes off and TUBE CURRENT meter drops to zero.
15. Turn kVp CONTROL fully counterclockwise and verify that TUBE CURRENT meter indicates zero.
16. Open compartment door and remove specimen and film.
17. Close compartment door.
18. Process film in normal manner.
19. Record final kVp indication and the TIME DISPLAY indication, along with specimen description and film type for future reference.

3.6 APPLICATIONS INFORMATION.

This section provides applications information and basic radiographic techniques recommended for Faxitron operation, with additional comments relating to specific problems that can occur.

3.6.1 X-ray Damage - Radiographic Samples.

Most components and certain semiconductor samples, are not affected by the X-ray dose required for normal radiography but may be damaged by high radiation doses. You may wish to determine, by literature survey, data in section 1 or by direct experiment, how such radiation may affect the sample you are radiographing. Note that live biological specimens are likely to be affected. The delivered dose can be minimized by:

- a. Using radiation beam filters and the highest kVp possible consistent with necessary resolution.
- b. Using the fastest film speed (i.e., highest FILM SELECTOR position) consistent with necessary resolution.

3.6.2 Magnification (see Figure 3-3).

Magnification is obtained anytime the object is placed between the X-ray source and the film. Referring to Figure 3-3, the magnification factor MF is defined as follows:

$$MF = SID/SOD = IS/OS \text{ where}$$

- SID = Source to Image Distance
- SOD = Source to Object Distance
- IS = Image Size
- OS = Object Size

Magnification can be used to enhance the resolution of a radiograph, but one must consider the limitations caused by geometrical unsharpness discussed in the following paragraph.

Note that if the object is very thin and it is placed directly on the film, the magnification factor is 1.

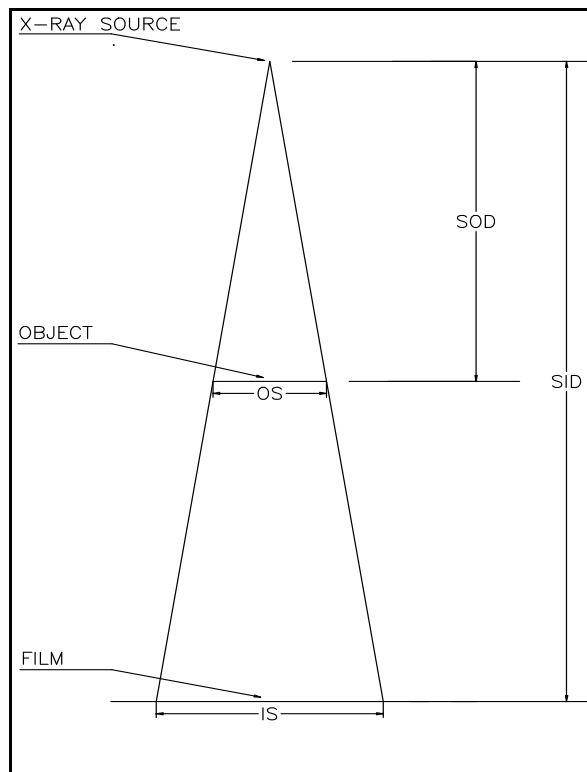

3.6.3 Geometric Unsharpness (see Figure 3-4).

Geometric unsharpness is a result of the size of the focal spot and the amount of magnification used. This is illustrated in Figure 3-4. For better clarity in the illustration, please note that the size of the focal spot is shown larger than normal.

The nominal focus spot on the X-ray tubes used in the Faxitron systems measures 0.05, 0.07 and 0.5 mm. At maximum load on the X-ray tube the effective size of the focal spot will be somewhat larger than the nominal size.

Examining thick objects can cause, what is normally referred to as "un-wanted" magnification. This, in combination with using a large focus spot size, may result in geometric unsharpness. The problem can usually be minimized by selecting a larger Source to Image Distance, (SID), thus decreasing the amount of un-wanted magnification..

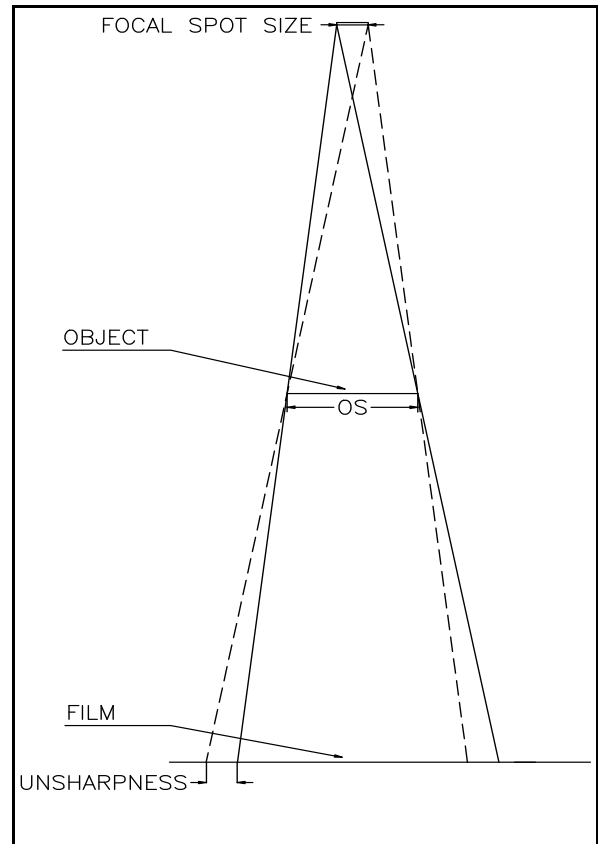

3.6.4 Scatter Radiation

Scatter radiation (also referred to as secondary radiation) is caused by X-rays being re-radiated at various angles when the primary beam is passing through an object. When the scatter radiation reaches the film from any angle different from the primary beam, the quality of the image will decrease.

Figure 3-5 shows scatter radiation originating from the object itself, the shelf, the cabinet floor and from the sensor assembly used with the optional Automatic Exposure Control (AEC). The problem with scatter radiation is greater at higher kVp and with radiographically "thick" subjects. Under these conditions, proportionally greater amounts of scatter is generated by the items in the primary beam.

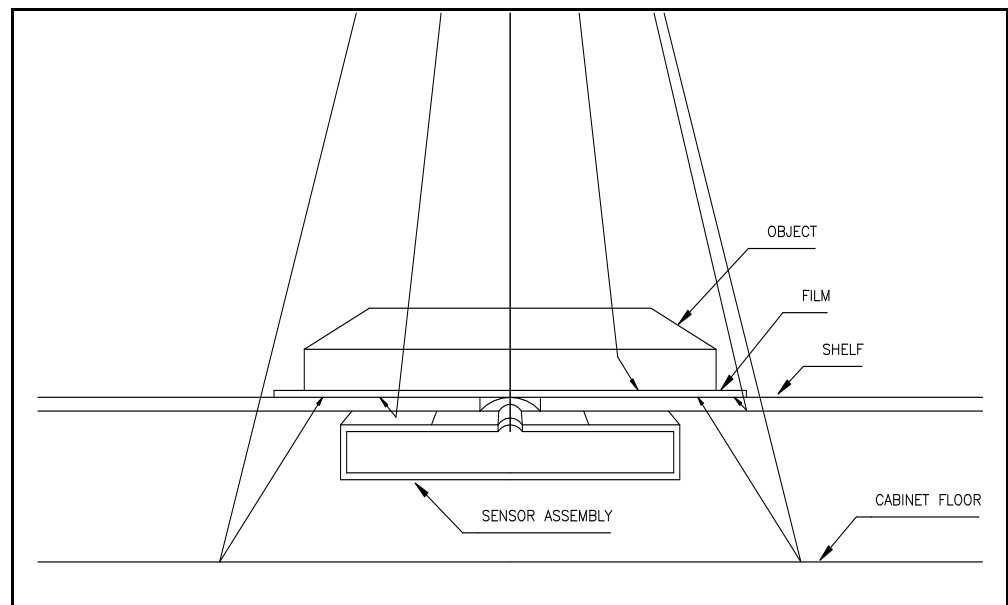

cont. Scatter Radiation

Reducing the amount of scatter radiation reaching the film.

For optimum radiographic quality, the use of adequate "masking" as shown in Figure 3-6, is recommended. The masking is essential at high kVp and/or in radiography of thick objects. "Masking" using 1.5 mm lead can be placed around the object and should be sufficient for most items. A "masking" using 3 mm lead should be used for radiography of steel items exceeding 6 mm in thickness. It also may be desirable to cover holes or thin sections (not of direct interest) in the subject with thin lead strips or lead pellets.

For radiographs involving long exposure times and voltage exceeding 90 kVp, lead film pack are recommended since these also filter out much of the scatter radiation from the object, thus improving the contrast and the resolution. Primary beam copper filters with 0.2 or 0.5 mm thickness can also be used to reduce the effect of scatter radiation.

When using the Automatic Exposure Control option A02, also, consider the following:

The film holder shelf incorporates design features which will permit ideal radiographs to be obtained under most exposure condition. It is, of course, necessary to have a hole in the shelf which allows the X-ray beam to reach the sensor assembly. This hole does not always backscatter X-rays in exactly the same pattern as the shelf. An occasional radiograph may show a ring or disc, with the same diameter as the hole in the shelf. The area of the hole will be either darker or lighter than adjacent areas.

The referenced ring or disc can normally be eliminated by using sufficient masking or if higher kVp is used, by means of lead film packets. If the problem occurs at low kVp, it may be necessary to record the kVp and time with an AUTO exposure, and use this data to set kVp and time in the MANUAL mode. When making the exposure in MANUAL mode, one should use a sheet of copper or steel to completely underlay the film.

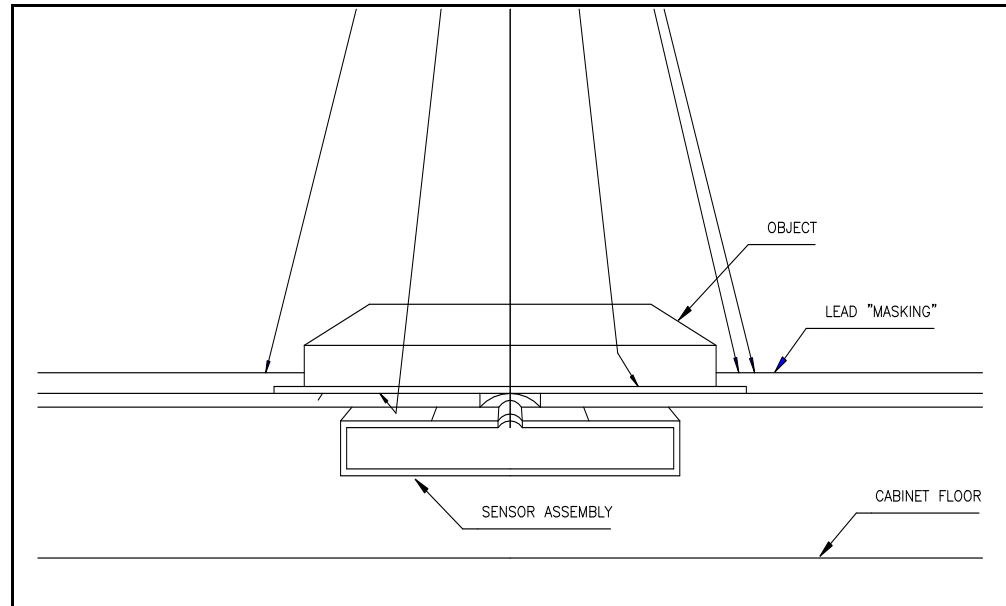

3.6.5 Low kVp Operation.

When operating at 10 - 20 kVp, consider the following:

- a. The absorption in the film and the film holder at this low kVp can be a problem. Use single coat high resolution film, or high resolution plates and where practical, avoid the use of a film packet or holder by using the system in a darkroom with the object placed directly on the emulsion side of the film.

Small objects or wet objects such as biological specimens, which are difficult to handle in the dark, may be placed on a very thin polyethylene film (0.01 mm), such as a section from a typical dry cleaners bag. Do not use Saran[®] Wrap because of its relatively high X-ray absorption. For handling ease, it may be convenient to make a cardboard frame, stretching the polyethylene film across it. This relatively simple device will facilitate object handling and protect the film emulsion.

- b. With the Automatic Exposure Control, option A02, the absorption in the film and film holder will reduce the amount of radiation reaching the sensor assembly. This will cause the film to be overexposed. To overcome this problem, insert the object alone (without film and holder), and expose it as if taking a normal radiograph. Record the kVp and time, and use this data for a MANUAL exposure (with film and holder).

3.6.6 Positioning the Object - Automatic Exposure Control, option A02.

When using the Automatic Exposure Control option, it is very important to position the light and dense areas of the object correctly over the sensor aperture. Figures 3-7 and 3-8 illustrate an extreme situation where part of the object is of plastic and part of it is of steel. If one wants to examine the steel part of the object, positioning should be according to Figure 3-7. If the area containing the plastic is to be examined, position should be according to Figure 3-8.

Positioning according to Figure 3-7 will result in overexposure under the plastic part, while positioning according to Figure 3-8 will result in underexposure under the steel part.

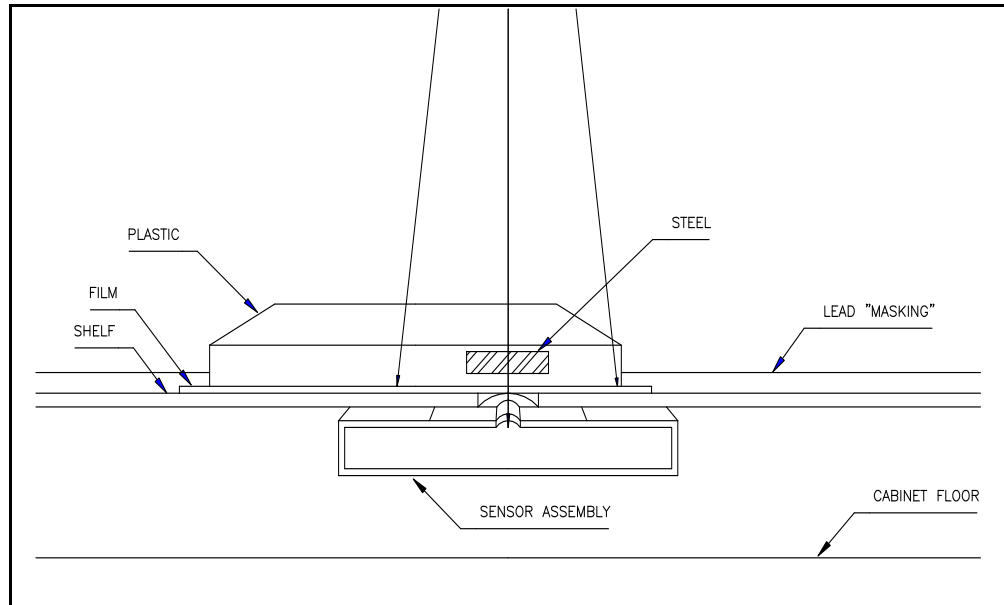

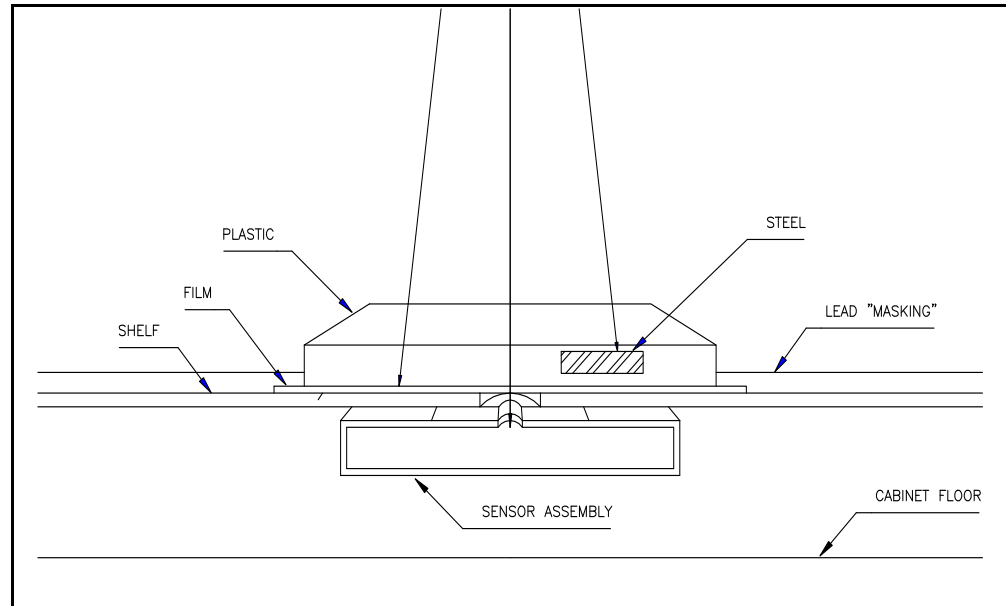

3.6.7 Fluoroscopy Viewing

The image on the fluoroscopic screen can best be observed if the operators eyes have been dark adapted. Optimum dark adaptation of the eye takes a surprisingly long time as shown in Figure 3-9.

Further dark adaptation from artificial white light is much more rapid than from daylight, which contains a higher proportion of blue light. The eye can be exposed to red light which is thirty times as bright as white light without loss of adaptation, and the nuisance factor of the dark adaptation waiting time can therefore be alleviated by wearing goggles. This also allows the operator to move about freely without loss of adaptation. It is important that the goggles be well fitted - red spectacles are not adequate.

It is quite important to remember that the light adapted state may not be regained in just a few minutes, and one must go through the dark adaptation process again if the operator is careless.

If a considerable amount of fluoroscopy is to be done, it may be advisable to locate the FAXITRON system in a room which can be illuminated with red lights for the periods of fluoroscopic operation.

In summary, for optimum use of the fluoroscopic operation:

1. Locate the X-ray system in an area away from windows and out of brightly lighted areas. If possible in an area that can be darkened and then illuminated with red lights.
2. Dark adapt eyes before viewing. Wear red goggles to keep your eyes dark adapted if further viewing is anticipated.

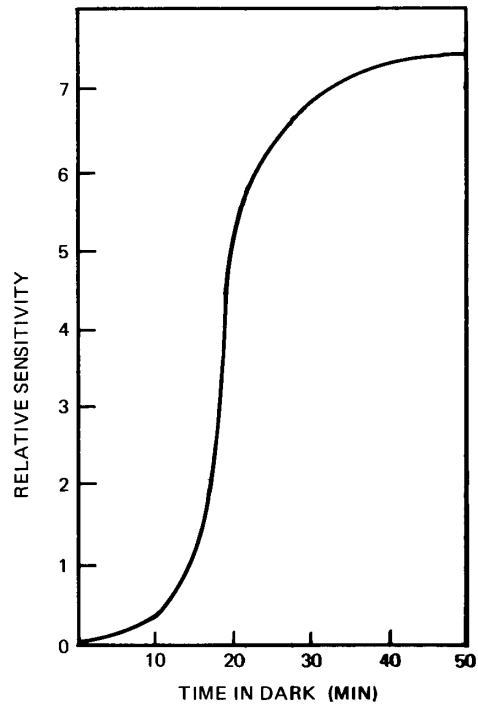

FILM SELECTION GUIDE FOR FAXITRON WITH AUTOMATIC EXPOSURE CONTROL, OPTION A02				
TYPE OF FILMS			FILM SELECTOR SETTING	FINE EXPOSURE CONTROL
POLAROID FILMS				
TYPE 51			5	DARK
TYPE 52			0	MID-RANGE
TYPE 55			1	MID-RANGE
TYPE 57			0	LIGHT
TYPE TPX			0	LIGHT
CONVENTIONAL X-RAY FILMS				
KODAK	DUPONT	AGFA GEVAERT		
AA SO-146	NDT75	D-7	0	LIGHT
T			5	MID-RANGE
	NDT65	D-5	5	LIGHT
M, RP/M	NDT55	D-4	3	LIGHT

	NDT45		2	DARK
R (DBL EMULSION)			1	LIGHT
R (SGL EMULSION)	NDT35	D-2	1	MID-RANGE

NOTE: (1) All film is assumed to be in paper cassettes. Most plastic cassettes are equivalent to paper cassettes at kilovoltage settings above 30 kVp. For best results, use only paper cassettes below 30 kVp.
 (2) Below 30 kVp, the FINE EXPOSURE control, should be turned clockwise ¼ turn.
 (3) Development time for wet Industrial film is 5 minutes at 68 deg. F, using KODAK X-RAY LIQUID developer and replenisher.
 (4) Either remove lead backscatter shield from cardboard exposure holder or compensate by turning to lighter setting (lower number) depending on kVp
 (5) FINE EXPOSURE control. This control is marked to correspond with X-ray film which produces a negative image. When the control is set to the DARK position, the film will receive more radiation which will make it darker. The response of the control to a 4 x 5 Polaroid film will be opposite since the film produces a positive image.

Table 3-1. Film Selection

KILOVOLTAGE SELECTION GUIDE					
MATERIAL THICKNESS IN MILLIMETERS	AUTOMATIC EXPOSURE MODE FILM SELECTOR POSITION			MANUAL MODE	
	No.1-No.2	No.3-No.4	No.5		
STEEL 0 to 3 3 to 6 6 to 12 Over 12		60-110 kVp 110-130 kVp	50-110 kVp 90-110 kVp 110-130 kVp	80-110 kVp 110-130 kVp 110-130 kVp	Use Intensifying Screens 90-130 kVp
ALUMINUM 0 to 3 3 to 19 19 to 38 38 to 62 Over 62	30-70 kVp 60-110 kVp	20-50 kVp 50-80 kVp 70-110 kVp 110-130 kVp	90-110 kVp 110-130 kVp		
FILLED EPOXY RESIN 0 to 3 3 to 19 19 to 38 38 to 76 Over 76	20-50 kVp 40-70 kVp 60-100 kVp	15-40 kVp 30-50 kVp 50-70 kVp 60-110 kVp	50-70 kVp 60-110 kVp		
ACRYLIC RESIN 0 to 3 3 to 19 19 to 38 38 to 62 Over 62	15-30 kVp 25-45 kVp 40-70 kVp 60-110 kVp	10-25 kVp 20-35 kVp 30-50 kVp 40-80 kVp 70-110 kVp			
<p>See Table 3-1 for film types vs. film selector position number. The above tabulation is based on exposure times generally between 1 and 10 minutes (10 and 100 minutes if a micro-focus X-ray tube is used), and use of slower film speeds (lower selector position number) to obtain minimum "grain size" and hence best film resolution. An exception would be radiography of objects where extreme contrast is required to show slight changes in density or composition - here low kilovoltage is necessary and faster film speeds may be required. Another exception involves radiography of objects which may be affected by X-rays.</p>					

Table 3-2. Selecting Kilovoltage for Various Materials.

SECTION 4
PRINCIPLES OF OPERATION

CONTENTS	PAGE
4.1 Introduction.....	4.1
4.2 Description of Block Diagram	4.1
4.3 Control Section	4.1
4.4 Cabinet Assembly.....	4.1
4.5 X-ray Tube Enclosure	4.1
4.6 Option A02, Automatic Exposure Control	4.1
4.7 System Circuit Description.....	4.2
4.8 H.V. Primary	4.2
4.9 X-ray Tube Filament Circuit.....	4.2
4.10 Magnetic Amplifier Operation	4.2
4.11 Overcurrent Protection	4.3
4.12 Turn off Circuit.....	4.3
4.13 Low Voltage Power Supplies	4.3
4.14 Timer Display Board	4.4
4.15 Time Display, Manual Mode	4.4
4.16 Time Display, Automatic Mode	4.4
4.17 Timing Circuit	4.4
4.18 Latch Circuit	4.5
4.19 Manual Mode operation.....	4.5
4.20 Display Brightness.....	4.5
4.21 Turn Off	4.5
4.22 Tube Voltage Display	4.5
4.23 Tube Current Bar Graph.....	4.5
4.24 Automatic Exposure Control.....	4.6

SECTION 4

PRINCIPLES OF OPERATION

4.1 INTRODUCTION

This section describes circuit details of the Faxitron X-ray System. First is a brief description based upon the block diagram located in section 6 of this manual. A more detailed description follows.

4.2 DESCRIPTION OF BLOCK DIAGRAM (see section 6).

Each standard X-ray system consists of four major subassemblies.

1. Control Section, A1.
2. Cabinet Assembly, A3.
3. X-ray Tube enclosure, A4.
4. Auto exposure components not located in control panel, A2

4.3 CONTROL SECTION

The control section provides the manual operating controls and indicators. The kVp CONTROL adjusts the anode voltage to the X-ray tube. The TIME SET thumbwheels select the exposure time. A bar graph indicates X-ray tube current while digital readouts indicate X-ray tube voltage (kVp) and exposure time.

X-ray tube current is regulated by a magnetic amplifier. Overcurrent protection is provided by a current sensing circuit which removes X-ray tube anode voltage if current becomes excessive.

4.4 CABINET ASSEMBLY

The Single Cabinet model 43855A is standard. The Dual Cabinet 43855B and the Table System 43856 are available where greater source to image distance (SID) or ability to accommodate large radiographic subjects is required.

The cabinet or drawer provides a radiation shielded compartment for radiographic use. Extensive use of lead shielding is incorporated into the design. The door and drawer are provided with safety interlock switches to prevent X-ray generation when the door or drawer is not completely closed.

4.5 X-RAY TUBE ENCLOSURE

The X-ray tube enclosure is mounted directly behind the control section and above the shielded compartment. The tube enclosure contains the X-ray tube, the X-ray tube filament transformer, two high voltage transformers, and a protective thermal switch. The enclosure is filled with a petroleum based high temperature transformer oil. The oil provides high voltage insulation and helps dissipate the heat generated by the X-ray tube. The oil DOES NOT contain PCB.

Lead shielding within the tube enclosure ensures that radiation is well within the limits set forth by the Bureau of Radiological Health, a Division of Health and Human Services.

4.6 OPTION A02, AUTOMATIC EXPOSURE CONTROL (AEC)

The AUTOMATIC EXPOSURE CONTROL consists of two sections:

1. An X-ray sensor located in the shielded radiation compartment.
2. The controls and amplifier section located in the control panel.

The automatic exposure feature responds to X-rays in a manner similar to the way that an automatic exposure camera responds to light. A FILM SELECTOR switch is set to correspond to film speed (sensitivity). The film and subject are placed between the X-ray sensor and the X-ray source (X-ray tube). When the sensor receives enough radiation for a properly exposed film, the circuit terminates the exposure.

4.7 SYSTEM CIRCUIT DESCRIPTION

This detailed circuit description is keyed to the electrical schematic diagrams in section 6 of this manual.

Refer to block diagram Figure 6-1 and schematic Figure 6-2. Power is applied through circuit breaker CB1 located under the sliding cover of the front panel. Placing the circuit breaker in the "ON" position, makes power available to the control unit. Closing the safety lock switch S1, makes power available to the kVp control variable transformer T1 and the filament voltage regulator A2-T1. A2-T1 is a pre-regulator for the X-ray tube filament circuit.

4.8 H.V. PRIMARY

The variable voltage output from the kVp control is connected to power relay K1 pin 5 through the 8 amp fuse F1. Closure of this relay applies power from pin 8, through the normally closed push-button switch S5 (press to read TP2) located under the sliding cover of the front panel, through the door interlock switch S3, and to the high voltage transformers A4-T1 and A4-T2.

4.9 X-RAY TUBE FILAMENT CIRCUIT

AC power to the magnetic amplifier T2 is supplied through the pre-regulated transformer T1. Diodes CR1 and CR2 conduct on alternate halves of the power line cycle. Current from the magnetic amplifier flows through R9 which is connected across the normally open contacts, pins 9 and 6 on the power relay. The circuit includes R4 across test point 1, the mA adjust control R5, and the X-ray tube filament transformer A4-T3.

The X-ray tube filament operates at reduced power, (voltage dropped by R9) when the SAFETY LOCK switch is turned on. Approximately 15 seconds warm-up of the X-ray tube filament is recommended before any exposure is made.

In order to produce X-rays, all interlock switches must be closed. Current flows through the normally closed thermal switch A4-S1, through the door interlocks S1 and S2 to the turn off relay K2. From the turn off relay, the current path is through the normally closed contacts of X-RAY STOP SWITCH S3, the X-RAY START SWITCH S4 and to the power relay coil pin A. The relay closes and latches through pins 4 and 7. Pins 6 and 9 bypass R9 allowing the X-ray tube filament to reach its full operating temperature. The mA ADJUST control R5 provides a service adjustment for X-ray tube current.

Voltage proportional to X-ray tube current is developed across resistors A4-R1 and R2. This voltage is applied to pin 2 of U7, through an active filter U7. U7 inverts the signal and provides a voltage (labeled FB) to the magnetic amplifier driver U3, the overcurrent comparator U2 and the TUBE CURRENT bar graph driver U13 (page 6.3).

4-10 MAGNETIC AMPLIFIER OPERATION

Refer to Figure 4-1 and the control board schematic page 6.2. As the tube current increases, the magnitude of the feedback voltage from the tube enclosure A4, increases. U3 is a comparator that sinks current through the magnetic amplifier control winding. As the input becomes positive with respect to the current set reference voltage, current flows in the magnetic amplifier control winding.

The magnetic amplifier consists of two toroid cores, each with a single load winding. Power line current passes through each winding in only one direction due to the series diodes CR1 and CR2. These windings are not magnetically coupled.

- a. Since the current through the load windings is in one direction only, the cores do not reset. The cores are driven toward saturation and the series impedance of the windings approach the resistance of the wire.

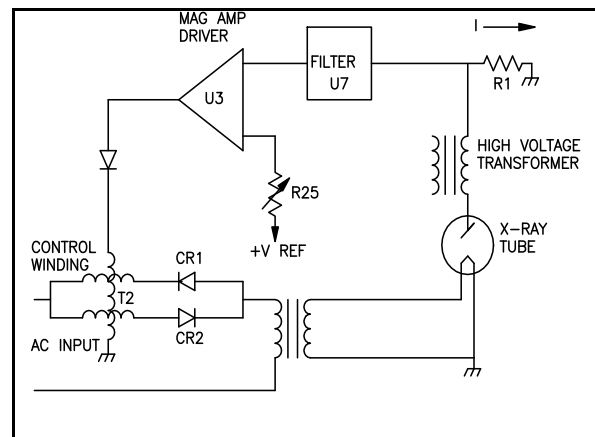

- b. The control winding is magnetically coupled to both load windings. Direct current flowing in the control winding drives the cores away from saturation so the load winding impedance now is $R+J_{XL}$ with XL much greater than R .
- c. A feedback voltage is developed across $R1$ which is proportional to the X-ray tube current, I . This feedback voltage is filtered and used to drive an amplifier which sinks current through the magnetic amplifier control winding.
- d. The X-ray tube current is controlled by limiting the filament temperature. The magnetic amplifier is a variable impedance in series with the filament transformer primary winding.
- e. If the tube current increases, the feedback voltage increases. This causes more current to flow in the magnetic amplifier control winding which reduces the magnetic flux in the load windings. Reducing the flux increases the load winding impedance which reduces the tube filament voltage (temperature) causing the anode current to decrease. $R2$ is a voltage divider which sets the tube current.
- f. Should the tube current decrease, the feedback voltage decreases reducing the magnetic amplifier control current. XL decreases due to the cores operating closer to saturation and the tube filament temperature increases which raises tube current. Enough filtering is built into the circuit to smooth the response and prevent oscillation.

Since the X-ray tube current is controlled by the filament temperature, above 30 kV, a few degrees temperature change can make a significant change in X-ray tube current.

4.11 OVERCURRENT PROTECTION (see page 6.2).

The overcurrent trip-out consists of comparator $U2$. Output from $U7$ is applied to input (pin 2) of $U2$. A reference voltage is applied to the input, pin 3. The output of $U2$ is normally low until the input to pin 2 exceeds the reference voltage.

- a. $U2$ connected as a comparator (inverting). Positive bias at negative input produces negative output. $R27$ provides adjustable reference.
- b. Positive feedback from $U7-6$ is applied to negative input. If F.B. becomes excessive, comparator output switches positive.

The feedback amplifier-filter circuit function is as follows:

- a. $U7$ provides filtering/isolation between the X-ray tube and the circuits driven by feedback from the X-ray tube (magnetic amplifier, overcurrent trip and tube current bargraph).
- b. Filtering is provided by the RC network in the amplifier input. The amplifier is connected in the inverting mode.

4.12 TURN OFF CIRCUIT (see page 6.2).

Input from the timing circuit (pin P4-7), the overcurrent trip out $U2-7$ and the auto exposure control (pin P4-5) if applicable, drive the OR gate $U8$. A low at all inputs, biases $Q1$ on, and closes the turn-off relay $K2$. The light emitting diodes on the gate inputs indicate the state of the inputs. A low at any input (LED ON), indicates that particular circuit is in an "operate" state. When a high is received at the OR gate from (a) the timer; (b) overcurrent; or (c) auto exposure complete, the turn-off relay $K2$ is opening, interrupting the interlock circuit, which terminates the exposure.

All inputs must be low to close relay $K2$. A high at any input will allow $K2$ to open, terminating the exposure. LED's $DS1$, $DS2$, and $DS3$ indicate the state of the input signals.

4.13 LOW VOLTAGE POWER SUPPLIES (see page 6.2).

Transformer $T1$ (located on the control board) supplies voltage for the 5 and the 12 volts DC rectifier and regulator circuits. $CR3$ and $CR4$ are connected in a full wave center tapped configuration. The 3-terminal regulator $U6$ provides a stable +5 volts source. $CR5$ is a full wave bridge, but because it is connected to a winding with a grounded center tap, it acts as two independent supplies. $U4$ and $U5$ regulate + and - 12 volts supplies respectively.

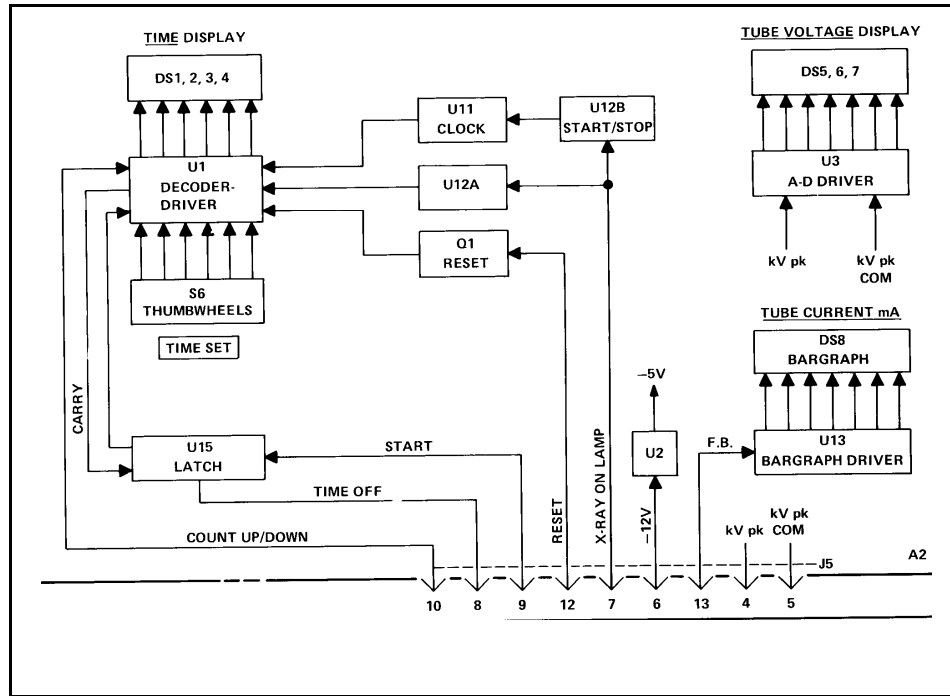

4.14 TIMER DISPLAY BOARD (see Figure 4-2 and page 6.3).

The timer circuit consists of:

- a. U1, a 4-digit up/down counter display driver.
- b. S6, a 4-digit thumbwheel switch.
- c. U11, a clock integrated circuit.
- d. U12, a comparator.
- e. U15, configured as a bi-stable latch.
- f. Q1, a transistor for resetting the counter.

4.15 TIME DISPLAY, MANUAL MODE (see Figure 4-2 and page 6.3).

The time is displayed on the 4-digit display DS1 through DS4. When operating in the manual mode (without the AEC option), the time is selected by the TIME SET thumbwheels. The time display is normally blank but lights when the X-RAY START switch is pressed and indicates the numbers set on the TIME SET thumbwheel switches. The countdown begins immediately and proceeds in one second increments. When the display indicates zero, the exposure terminates and the display blanks out.

4.16 TIME DISPLAY, AUTOMATIC MODE (see Figure 4-2 and page 6.3).

Time is displayed as described above, but a high at the up/down pin 10 of U1 causes it to count from zero upward in one second increments, until the auto exposure sensor terminates the exposure. At this point, the display holds the exposure time indication until the X-RAY START switch is pressed for the next exposure, or until the unit is switched back to the manual (timed) mode.

4.17 TIMING CIRCUIT (see Figure 4-2 and page 6.3)

The timing circuit consists of a crystal controlled clock integrated circuit U11, and comparator U12. The clock output enable pin 11 on U11, is normally low which inhibits the clock output.

When the X-RAY START switch is pressed, low voltage ac from the X-RAY ON lamp transformer T2 on page 6.2 goes to pin J5-7 of the display board and onto half wave rectifier CR15. The rectified voltage is clipped by CR16, filtered and applied to the comparator U12A input. The comparator U12A then pulls down pin 9 of U1 which remains low throughout the exposure. The positive output from U12B is applied to the clock enable pin 11 of U11. U11 outputs one second clock pulses until the exposure is terminated.

4.18 LATCH CIRCUIT (see Figure 4-2 and page 6.3).

The quad nand gate U15 is configured as a bi-stable latch. Upon power application, the latch comes on with pin 8 high and pin 6 low. The latch is set by the X-RAY START switch and reset when the carry pin 1 of U1 goes low at the end of the exposure. The latch drives the time turnoff circuit U8 pin 1 on the control board and the preset function, pins 11 and 12 of the timer/display driver U1.

4-19 MANUAL MODE OPERATION (see Figure 4-2 and page 6.3).

J5-10 is held low causing U1 to count down from the pre-set time. The output of latch circuit U15-8, is an active high, causing U1 to be loaded with BCD data from the TIME SET thumbwheel switches. When the X-RAY START switch is closed, J5-9 goes low which produces a low on U11-11 and a high on J5-8 which closes the turn-off relay contacts.

Low voltage ac at J5-7, switches the comparator U12A to the low state, which deactivates the store function of U1. The clock I.C., U11, outputs one second signals to U1-8. U12B goes high enabling the clock output which furnishes one second pulses to the timer U1.

4.20 DISPLAY BRIGHTNESS (see page 6.3).

The display brightness is controlled by an oscillator incorporated into U1. The oscillator frequency can be controlled by a capacitor (C1) but this capacitor can in most cases be omitted.

4.21 TURN OFF (see pages 6.2 and 6.3).

Count down begins when the X-RAY START switch is pressed. When the count reaches zero, U1-1 outputs a positive pulse to the latch U15 pins 1 and 2. This produces a high at U15-8 which drives the TIME OFF input to U8-1 on the control board. U8 produces a high at the base of Q1, allowing the turn-off relay to open. This opens the interlock circuit and opens the power relay K1, terminating the exposure.

4.22 TUBE VOLTAGE (kV) DISPLAY (see pages 6.2 and 6.3).

The TUBE VOLTAGE display, DS5, DS6 and DS7, is a 2½ digit display driven by U3. U3 is an A and D converter combined with a display driver.

A small DC voltage, which is proportional to the X-ray tube anode voltage is applied to the U3 input. This DC voltage is furnished by U1 on the control board, which also isolates the A-D converter from the power line. Trimpots R21 on the control board and R9 on the display board are used for the kV calibration.

4.23 TUBE CURRENT (mA) BAR GRAPH (see pages 6.2 and 6.3).

A 10-segment bar graph display, U13 and DS8 on the display board, indicates X-ray tube current. A voltage is developed across the series connected resistors R1 and R2, located within the X-ray tube enclosure. The voltage, which is proportional to the X-ray tube anode current, is connected through the buffer amplifier U7 on the control board.

The bar graph driver, integrated circuit U13, contains a voltage reference and a 10-step voltage divider. A string of 10 comparators is connected to the divider. Each comparator drives one LED in the bar graph. The LED's are connected in a common anode configuration. As the input voltage increases, the comparators change state, in turn, sink current through the LED's. The bar graph array DS8, has 10 LED's mounted in a line. As the diodes light, the display appears as a solid, variable length bar of light. Eight segments of display equal 3.0 mA (0.3 mA if a micro-focus X-ray tube is used). The ninth segment is blanked out, so that if an overcurrent condition exists, which will light number ten, a definite break in the light bar will be visible.

4.24 AUTOMATIC EXPOSURE CONTROL (AEC), OPTION A02 (see Figures 4-3 and pages 6.4 and 6.5).

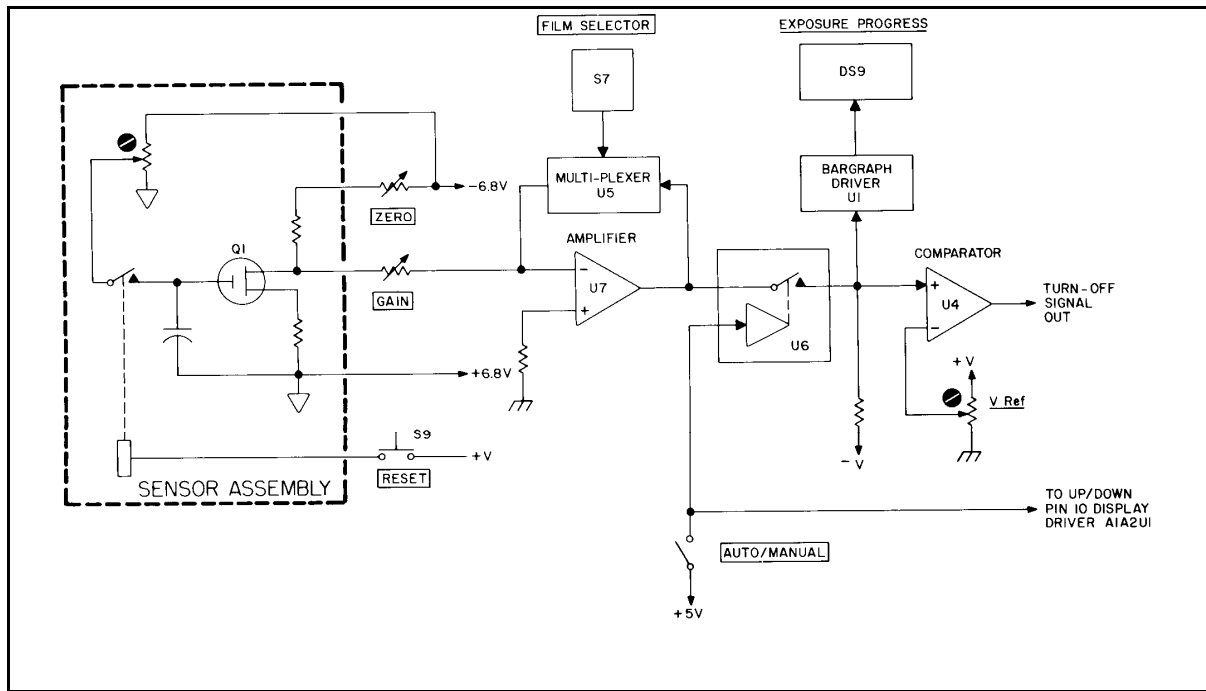

The sensor assembly is a shielded enclosure located on the lower surface of the shelf in the exposure chamber. The sensor is connected by a cable to the amplifier circuits located in the control section. For the following description, refer to the block diagram Figure 4-3 and to the schematic diagram page 6.4.

a. **SENSOR ASSEMBLY**

The sensor assembly includes an ionization chamber, a solenoid, and an enhancement mode P-channel MOSFET. The ionization chamber is an air dielectric capacitor. The chamber is charged by activating the solenoid (pressing the reset button). The solenoid connects the chamber to a negative voltage source. This voltage is a turn-on bias for the MOSFET, Q1.

b. **MOSFET CIRCUIT**

MOSFET Q1 has a very high impedance, so it appears as an open circuit to the charged capacitor (ionization chamber). The source and drain of Q1 are connected between series connected positive and negative 6.8 volt supplies. When the bias is properly adjusted, Q1 drain current is such that the output voltage (drain voltage) will be zero with respect to the reference point. The reference is the center connection between the two 6.8 volts supplies.

Once the chamber is charged, it is disconnected from the charging source. Any change in chamber voltage will be due to ionizing radiation or to leakage current.

Ionizing radiation (X-rays) striking the chamber cause it to discharge. The discharge rate depends on the intensity of the radiation. As the charge on the chamber becomes less negative, Q1 drain current decreases and the output voltage becomes more negative.

c. AMPLIFIER U7

The sensor output goes to the inverting input of the DC coupled amplifier U7. Amplifier gain is controlled by the FILM SELECTOR switch S7. Analog switch U6 is placed between amplifier U7 and comparator U4.

d. AUTO-MANUAL SWITCH

The AUTO-MANUAL switch S8 selects the mode of operation. The switch controls the count up/down of the time display and the analog switch U6.

e. FILM SELECTOR

When the RESET switch S9 is pressed: (a) the ionization chamber in the sensor assembly is charged and the output of the MOSFET becomes zero volts, the EXPOSURE PROGRESS bar graph DS9 indicates zero; and (b) the time display driver U1 receives a reset signal. However, the time display will not change until a signal is received from the X-RAY START circuit.

After an automatically terminated exposure, the time display will retain the exposure time indication until the X-RAY START switch is pressed for the next exposure.

f. ANALOG SWITCH U6

Placing the AUTO-MANUAL switch S8 in the AUTO position closes the analog switch U6, connecting the output of amplifier U7 to comparator U4. In the MANUAL mode, a negative bias is applied to the comparator and the bar graph driver inputs through R33. This bias ensures that the bar graph will not give an indication and that no false turn off signals will be produced in the manual operating mode.

g. COMPARATOR U4

The comparator U4 has an adjustable positive reference connected to its negative input, making the output normally low. When amplifier U7 output voltage exceeds the reference, the comparator output goes high producing an automatic turn-off signal. The turn-off is set to occur when the EXPOSURE PROGRESS bar graph indicates 100%.

h. EXPOSURE PROGRESS DISPLAY

DS9 is a 10-segment LED bar graph which displays the relative output of amplifier U7. It is calibrated in percent of exposure, so at any time the operator can judge the amount of time remaining to complete an exposure. The zero point on the bar graph is offset upscale by one segment. This aids in determining the zero set point for the sensor adjustment.

The display is connected to produce a moving dot (as opposed to a lighted bar as in the X-ray tube current bar graph). As the exposure progresses, each dot will light in sequence. The previously lighted dot will remain dimly lighted until the next dot is fully lighted. This will continue until the 100% dot lights at which time the exposure will terminate.

i. BEAM LOCATOR

The beam locator is attached to the inside upper surface of the exposure chamber. The beam locator is brought into use by pulling on the handle which swings the beam locator lamp directly over the sensor. The beam locator projects a V-shaped image of the lamp filament directly over the sensor window. The lamp is powered by transformer T5 through the voltage dropping resistor R20. The lamp turns on automatically when moved into the operating position, by a cam operated switch S1 mounted in the beam locator arm.

j. CABLE INTERCONNECT

The connections between the Auto Expose Board, the Control Board and the Display Board are shown in page 6.5.

SECTION 5
MAINTENANCE

CONTENTS	PAGE
5.1 Introduction.....	5.1
5.1.1 Test Equipment.....	5.1
5.1.2 Removing the Covers.....	5.3
5.2 Preventive Maintenance/ Safety Product Assurance Checks and Adjustments	5.4
5.2.1 Check that All Decals and Operator Safety Instructions are in Place.....	5.5
5.2.2 Check Resistance from Cabinet to Input Power Cord Pin.....	5.5
5.2.3 Check Resistance from Line and Neutral to Ground	5.5
5.2.4 Check for Proper Power Receptacle/Connector Polarity.....	5.5
5.2.5 Check and Adjustment of Compartment/Drawer Interlocks.....	5.6
5.2.6 Check Zero of Tube Current and kVp Meters.....	5.12
5.2.7 Check and Adjust kVp Meters	5.12
5.2.8 Check Battery for Option M55	5.13
5.2.9 Check and Adjust X-ray Tube Current.....	5.13
5.2.10 Check HV Transformer Primary Current	5.16
5.2.11 Verify Proper Operation of Manual Exposure Control	5.16
5.2.12 Take Standard Radiograph and Check for Satisfactory Operation.....	5.16
5.2.13 Check and Adjust Beam Locator.....	5.17
5.2.14 Check and Adjust Auto Exposure Control	5.18
5.2.15 Make Complete Radiation Survey	5.21
5.2.16 Check that Operating Personnel has Radiation Monitoring System.....	5.21
5.2.17 Clean Control Panel	5.21
5.2.18 Clean Air Filter	5.21
5.2.19 Clean Mirror and Fluoroscopy Screen.....	5.21
5.3 Disassembly and Repair Instructions	5.22
5.3.1 Fuse Replacement	5.22
5.3.2 Beam Locator Lamp Replacement.....	5.22
5.3.3 High voltage Enclosure - Lid Removal	5.23
5.3.4 Draining Transformer Oil from H.V. Enclosure	5.23
5.3.5 X-ray Tube Replacement	5.24
5.3.6 High Voltage Transformer Replacement	5.24
5.3.7 Filling High Voltage Enclosure with Oil.....	5.25
5.4 Troubleshooting.....	5.26
5.4.1 Troubleshooting the Display Section.....	5.26
5.4.2 Troubleshooting the Auto Expose Section	5.27
5.4.3 Troubleshooting the X-ray Generator Section	5.27

SECTION 5

WARNING

Serious injury (both physical and genetic) can result if all X-ray shielding is not properly replaced or interlocks are not operating after maintenance. Proper shielding replacement and interlock operation can only be confirmed by performing a radiation survey before placing the system in operation, and before use whenever the system is moved or serviced.

MAINTENANCE

5.1 INTRODUCTION

This section is presented in three categories:

- Preventive Maintenance/Safety Product Assurance Checks and Adjustments. (paragraph 5.2).
- Disassembly and Repair Instructions. (paragraph 5.3).
- Troubleshooting..... (paragraph 5.4).

5.1.1 Test Equipment

Test equipment required for preventive maintenance, operational tests, adjustments and troubleshooting are listed in Table 5-1.

INSTRUMENT		REQUIRED CHARACTERISTICS	REQUIRED FOR
TYPE	MODEL		
Survey Meter	Victoreen 450 P or equivalent	Accurate reading at 0.5 mR/hr	To survey system
Digital Multi-Meter (DMM)	HP 3466A or equivalent	True RMS 0.03% of reading 0.01 ohm resolution	Test point check Resistance measurements kVp calibration Adjustments General troubleshooting
Multi-Test Box	Faxitron 43805-69502	See Figure 5-1	Interlock checks HV transformer current X-ray tube current

Table 5-1. Recommended Test Equipment

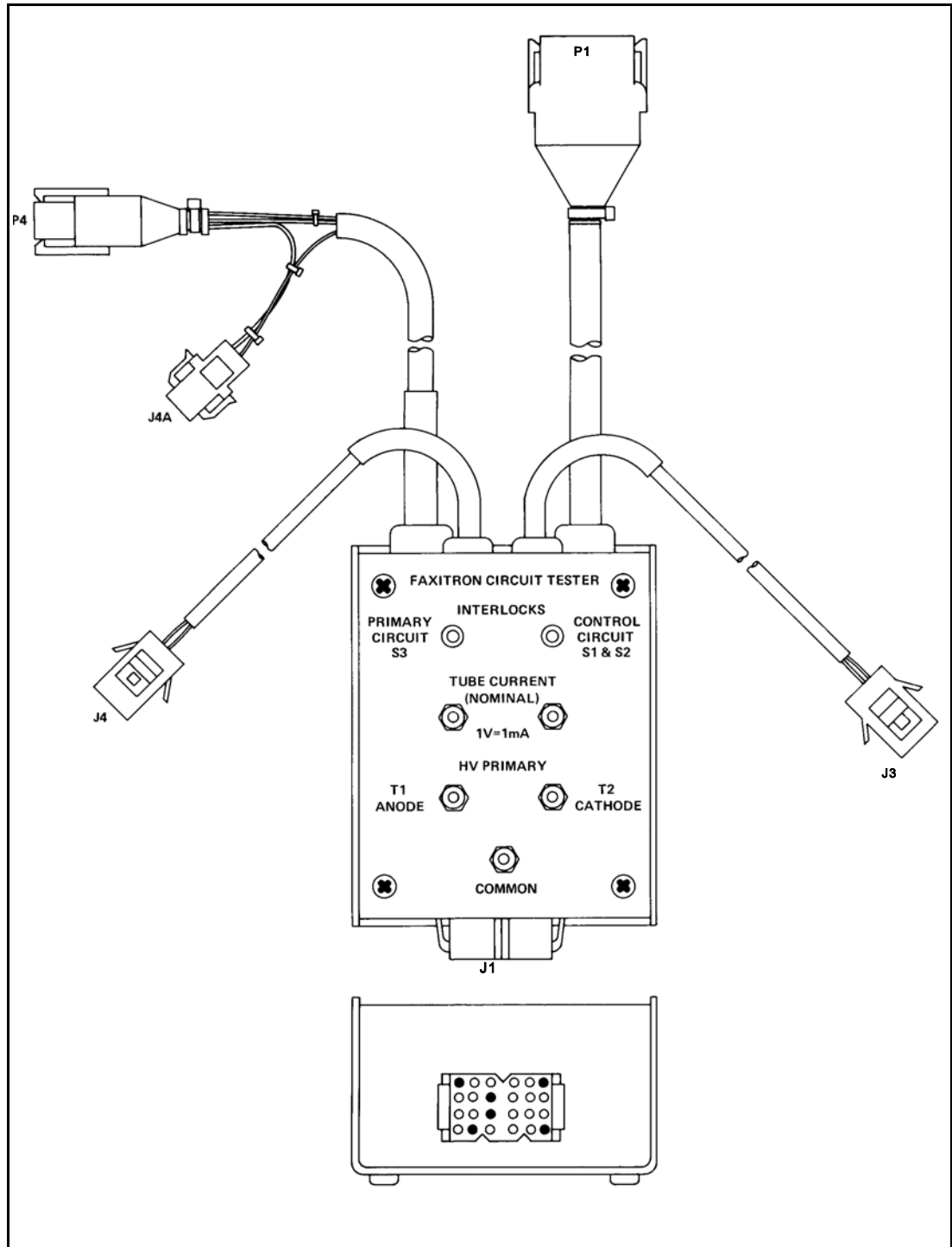

5.1.2 Removing the Covers (see Figure 5-2).

In order to perform maintenance, calibration and adjustments described in this section, the covers of the Faxitron may have to be removed.

a. Wrap Around Cover.

To remove the wrap around cover for the control unit:

Remove one screw from each side.

Remove the cover, by lifting it and sliding it back.

b. Side Covers.

To remove each of the two side covers:

Remove three screws from the back of the side cover.

Remove the cover by sliding it back and out.

When maintenance is completed, install the covers in reverse order.

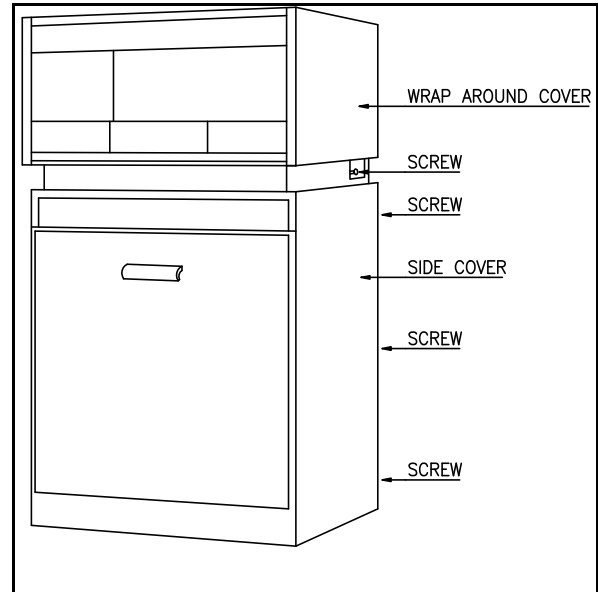

5.2 PREVENTIVE MAINTENANCE/SAFETY PRODUCT ASSURANCE CHECKS AND ADJUSTMENTS

Recommended preventive maintenance for Faxitron Systems includes visual inspection, cleaning, lubrication, any required adjustments, operational tests and periodic radiation surveys. The visual inspection, operational checks, and performance tests should also be used as preliminary troubleshooting steps and incoming inspection as applicable.

The following maintenance procedure should be performed:

a. Every 6 months - Safety Product Assurance

- Check that all decals and operator safety instructions are in place. 5.2.1
- Check resistance from cabinet to input power cord ground pin..... 5.2.2
- Check resistance from line and neutral to ground..... 5.2.3
- Check for proper power receptacle/connector polarity. 5.2.4
- Check and adjustment of compartment/drawer interlocks..... 5.2.5
- Check zero of TUBE CURRENT and kVp METERS..... 5.2.6
- Check and adjust kVp METER. 5.2.7
- Check battery for option M55..... 5.2.8
- Check and adjust X-ray tube current..... 5.2.9
- Check HV transformer primary current. 5.2.10
- Verify proper operation of manual exposure control. 5.2.11
- Take standard radiograph and check for satisfactory operation..... 5.2.12
- Check and adjust beam locator (AEC Option A02 only). 5.2.13
- Check and adjust Auto Exposure Control (AEC Option A02 only) 5.2.14
- Make complete radiation survey. 5.2.15
- Check that operating personnel has radiation monitoring system..... 5.2.16

b. Annual - Preventive Maintenance

- Clean control panel. 5.2.17
- Clean air filter..... 5.2.18
- Clean mirror and fluoroscopy screen (Fluoroscopic Option A15 only) 5.2.19

5.2.1 Check that all decals and operator safety instructions are in place.

Use Figure 1-3 (in section 1 of this manual) as a guide and verify that all decals and labels with safety instructions are in place.

5.2.2 Check resistance from cabinet to input power cord pin.

With the Digital Multimeter, check that the resistance from any exposed metal point of the cabinet to the power cord ground pin is less than 0.10 ohm. Make certain to check the resistance of the test leads (normally between 0.10 and 0.20 ohm) and subtract this from the reading obtained during the resistance check.

5.2.3 Check resistance from line and neutral to ground.

With the line cord disconnected from the power source, place a jumper lead between the line and neutral pins. Turn the CIRCUIT BREAKER and the SAFETY LOCK switch on. With the Digital Multimeter, check the resistance between the line/neutral pins of the power connector to the ground pin. The resistance should be equal to or more than 2 megohms.

5.2.4 Check for proper power receptacle/connector polarity.

Remove the covers of the Faxitron unit.

With the Digital Multimeter, check that the power receptacle to which the Faxitron unit is to be connected, has the proper polarities according to Figure 5-3.

Measure the AC voltage between ground and to the neutral and the line respectively.

Check also that the line cord of the Faxitron is wired correctly.

The ground pin of the connector should be connected to the Faxitron's chassis.

The neutral pin of the connector should be connected, via the circuit breaker and the on-off switch, to terminal J6 on the control board.

The line pin of the connector should be connected, via the circuit breaker and the on-off switch, to terminal J7 on the control board.

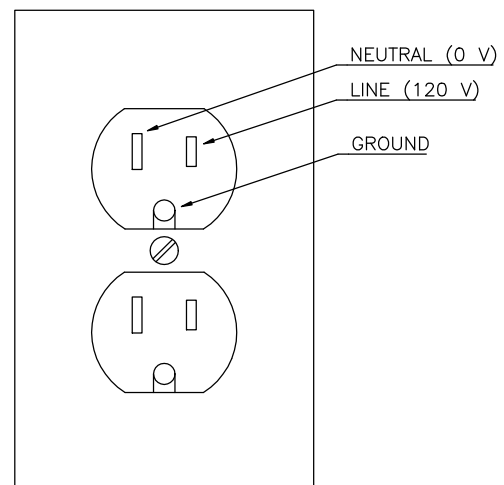

Note. If the Faxitron is installed with the Isolating Line Adapting Transformer (Option A03), the polarity is not important and this step can be omitted.

5.2.5 Check and adjustment of compartment/drawer interlocks.

Location of cabinet door interlocks.

There are three interlock switches S1, S2 and S3, which are activated by the compartment door. For location of the compartment door interlock switches, see Figure 5-4.

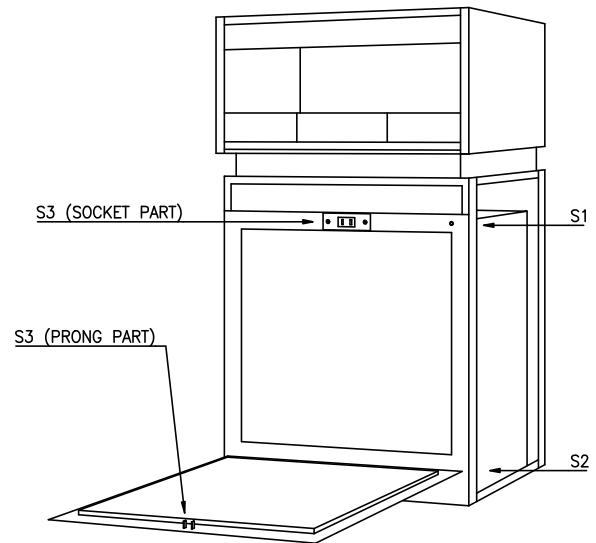

Location of table drawer interlocks.

In the table model 43856A there are also three interlock switches. S1 and S3 are activated directly by the table drawer. S2 is activated by the drawer lock handle. For location of the drawer interlock switches, see Figure 5-5. In addition to the switches, there is also a mechanical interlock of the drawer, that is activated by the drawer lock handle.

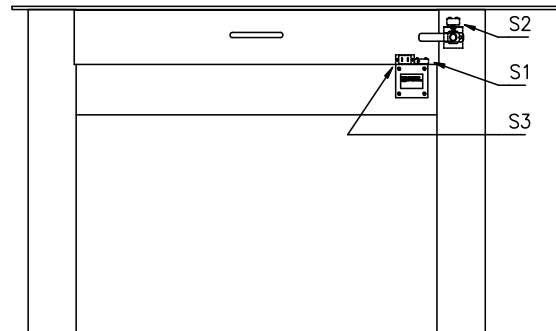

cont. Check and adjustment of compartment/drawer interlocks.

Circuit diagram for interlock switches.

Figure 5-6 shows a circuit diagram for the interlock switches. Please note the following:

Model 43855A, Single Cabinet System: Terminals 1 and 2 of TB1 and TB2 are jumpered.

Model 43855B, Dual Cabinet System: The functions of S1, S2 and S3 in the lower cabinet are the same as in the upper cabinet.

Model 43856A, Cabinet/Table System: S1, S2 and S3 are interlock switches for the table drawer.

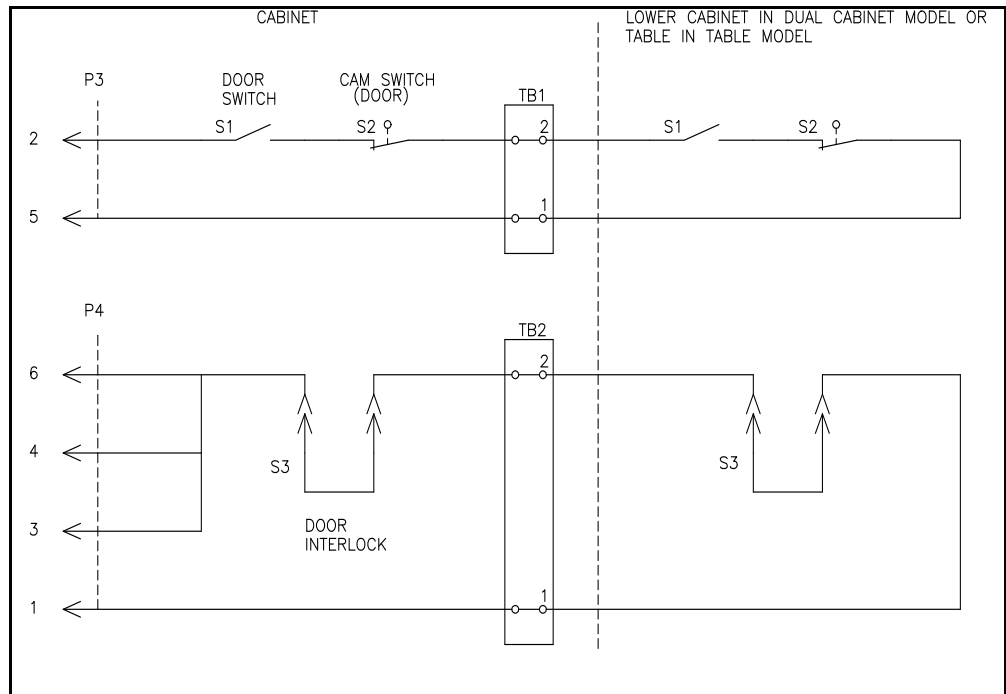

cont. Check and adjustment of compartment/drawer interlocks.

Check and adjustment of interlock switches.

The Multi-Test Box (Faxitron part number 43805-69502), shown in Figure 5-1, is used for this test. If the Multi-Test Box is not available, an ohm-meter can be used to check the operating point of each switch.

With the power turned off and the power cord disconnected from the AC source, connect the Multi-Test Box as follows:

- a. Unplug system's cable connector P3 from socket connector J3, located on the control circuit board. Connect the system's cable connector P3 to J3 of the Multi-Test Box (see Figure 5-1).
- b. Unplug system's series cable connector P4/J4, that is located in the cable running between door interlock switch S3 and the HV tube enclosure tank cable harness. Connect the system's cable connector P4 to J4 of the Multi-Test Box (see Figure 5-1).

With cabinet doors, (and in case of the Table Model, drawer also closed) both LED's on the Multi-Test Box should be on.

When all the checks with the Multi-Test box are completed, disconnect the box and restore the original connections.

Checking and adjusting door switch S1.

Open the door slowly. After approximately 1.5 mm (0.060") of travel at the top of the door, the door interlock switch S1 should open and the "CONTROL CIRCUIT" LED on the Multi-Test Box should turn off. For a precise check of the top of the door travel, use a feeler gauge (a number 53 drill) or a dial indicator.

If travel exceeds 1.5 mm (0.060"), adjust the switch by loosening the two nuts on top of the slotted bracket, as shown in Figure 5-7, and reposition the switch until the correct adjustment is obtained.

Tighten the nuts and re-check the adjustment.

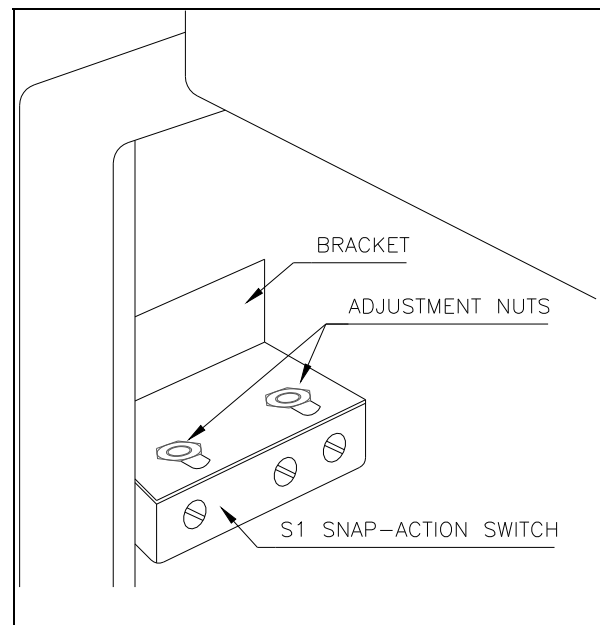

cont. Check and adjustment of compartment/drawer interlocks.

Checking and adjusting door switch S2.

Place a jumper lead across the terminals of switch S1.

Open the door slowly. After approximately 12 mm (0.5") of travel at the top of the door, the door interlock switch S2 should open and the "CONTROL CIRCUIT" LED on the Multi-Test Box should turn off. A piece of solid material approximately 12 mm (or 0.5") can be used as a feeler gauge to check the travel at the top of the door.

If travel exceeds 12 mm (0.5"), see Figure 5-8 and proceed as follows:

With the door completely closed, the sides of the cam should be approximately parallel to the face of the mounting bracket. If not, loosen the two 1/4" hex-headed adjustment screws and reposition the mounting bracket. Re-tighten the screws.

Wedge door open approximately 12 mm (0.5") using the "feeler gauge" described above.

Use a thin 9/16" open end wrench, and loosen adjustment nut nearest the switch body. Re-position the nut on the other side of the bracket as needed and re-tighten the nut nearest the switch body. Re-check the adjustment.

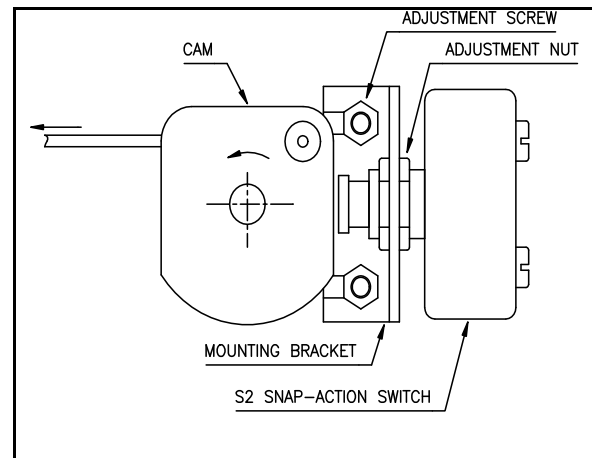

With the door fully open, verify that the switch plunger can be made to move away from the cam without bottoming out.

Remove the jumper lead from S1.

Checking and adjusting door switch S3.

Open the door slowly. After approximately 10 mm (0.4") of travel at the top of the door, the prong and socket type door interlock switch S3 should open and the "PRIMARY CIRCUIT" LED on the Multi-Test Box should turn off.

The door switch S3 is adjustable for alignment only by moving the socket receptacle. The movable switch blades should engage the slots in the center and engage the fixed switch blades without bumping end on.

If the blades do not engage smoothly, loosen the mounting screws, identified in Figure 5-9, enough to allow the switch to move, but tight enough to stay where it is positioned. Open and close the door a couple of times and tighten the screws at the position taken. After tightening, recheck for smooth operation.

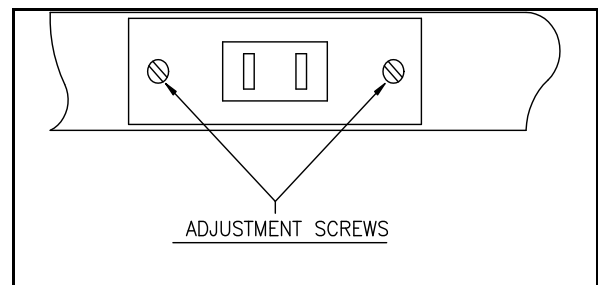

cont. Check and adjustment of compartment/drawer interlocks.

Note: With dual cabinet model 43855B, repeat the test and adjustment of door switches S1, S2 and S3 for the lower cabinet.

Checking and adjusting drawer switches in Table Model 43856.

As mentioned earlier and illustrated in Figures 5-5 and 5-6, the table drawer also has three interlock switches, S1, S2 and S3. The function of each switch is the same as the cabinet door interlock switches, but the ways they are activated, are somewhat different.

In order to access the handle interlock switch S2, remove the right side cover of the table base. The Multi-Test Box should remain connected as it was for checking the cabinet door switches.

Checking and adjusting drawer switch S3 in Table Model 43856.

The prong part of this switch is mounted inside of the lower front part of the drawer and the socket part is mounted on a bracket attached to the table apron below the drawer. See Figure 5-10. Check and if necessary readjust as follows:

- a. Turn the handle (Figure 5-10) to the open position - handle pointing down.
- b. Open the drawer slowly. After approximately 10 mm (0.4") of travel, the prong and socket type door interlock switch S3 should open and the "PRIMARY CIRCUIT" LED on the Multi-Test Box should turn off.
- c. The drawer switch S3 is adjustable for alignment only by moving the socket receptacle. Check, by opening and closing the drawer a few times, that the movable switch blades engage the slots in the center and engage the fixed switch blades without bumping end on.
- d. If the blades do not engage smoothly, close the drawer and loosen the four mounting screws, identified in Figure 5-10. This will allow the switch bracket to reposition itself. Make certain that lockwashers are installed and tighten the screws. Recheck for smooth operation.

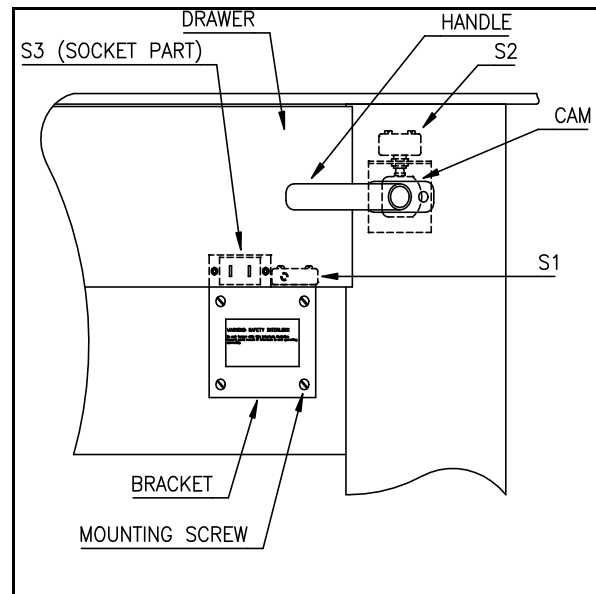

cont. Check and adjustment of compartment/drawer interlocks.

Checking and adjusting drawer switch S1 in Table Model 43856.

Place a jumper lead across the terminals of switch S2. This is necessary because S1 and S2 are connected in series and the handle which activate S2 is in an open position.

The snap action switch S1 is actuated by an angle clip mounted on the bottom of the drawer. Check the adjustment of the switch by opening the drawer slowly. After approximately 1.5 mm (0.060") of travel, the drawer interlock switch S1 should open and the "CONTROL CIRCUIT" LED on the Multi-Test Box should turn off. For a precise check of the drawer travel, use a feeler gauge (a number 53 drill) or a dial indicator.

If adjustment is necessary, reposition the activating clip in the bottom of the drawer. Slotted holes are provided for this adjustment. In order to protect the switch from excessive overtravel, move the clip only in small increments.

Recheck the adjustment and remove the jumper lead from S2.

Checking and adjusting drawer handle switch S2 in Table Model 43856.

Make certain that the drawer is completely closed and that the drawer handle is in its closed position, as shown in Figure 5-10. The "CONTROL CIRCUIT" LED on the Multi-Test Box should be on. With the drawer handle in the closed position, also check that the plunger shown in Figure 5-11 locks the drawer in its closed position.

Slowly turn the handle towards the open position. After approximately 12 mm (0.5") of travel at the end of the handle, the drawer handle interlock switch S2 should open and the "CONTROL CIRCUIT" LED on the Multi-Test Box should turn off.

If travel is less than 9 mm (0.4"), or more than 15 mm (0.6"), see Figure 5-11 and proceed as follows:

Use a thin 9/16" open end wrench, and loosen adjustment nut nearest the switch body. Re-position the nut on the other side of the bracket as needed and re-tighten the nut nearest the switch body. Re-check the adjustment.

With the handle in the fully open position, verify that the switch plunger can be made to move away from the cam without bottoming out.

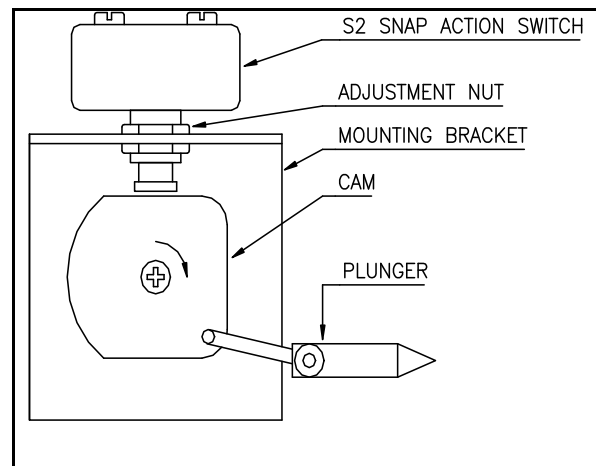

5.2.6 Check zero of Tube Current and kVp Meters.

Tube Current Meter (bar graph)

Check that at all times, except when an exposure is made, the Tube Current Meter (bar graph) is blanked out.

If this is not the case, turn the kVp Control to zero (full counter-clockwise), turn the Safety Lock Switch to OFF and remove the key. Call your Faxitron Xray Corporation Sales/Service office for assistance.

kVp Meter.

With the kVp Control turned to zero (full counter-clockwise), the kVp Meter should indicate 00 or 01.

5.2.7 Check and adjust kVp Meter.

With the circuit breaker off, connect the DMM's leads to terminals 3 and 4 on the kVp control terminal board. See Figure 5-12.

Turn the kVp control fully CCW and turn the circuit breaker and the lockswitch on. Verify zero volts AC on the DMM.

Use Table 5-1 and check that the DMM voltage correspond at maximum and at 40 kVp.

If adjustments are necessary, alternately adjust R9 (see Figure 5-12) at maximum kVp and R21 at 40 kVp until the correct AC voltage for each kVp value according to Table 5-1 is obtained.

	Standard 110 kVp		Option A04 130 kVp		Option M55 55 kVp	
DMM VAC	118 ±0.25	42.9 ±0.5	118 ±0.25	36.3 ±0.5	118 ±0.25	85.8 ±0.5
kVp Meter	110	40	130	40	55	40
Adjustment	R9	R21	R9	R21	R9	R21

Table 5-1. Check and Adjustment of kVp..

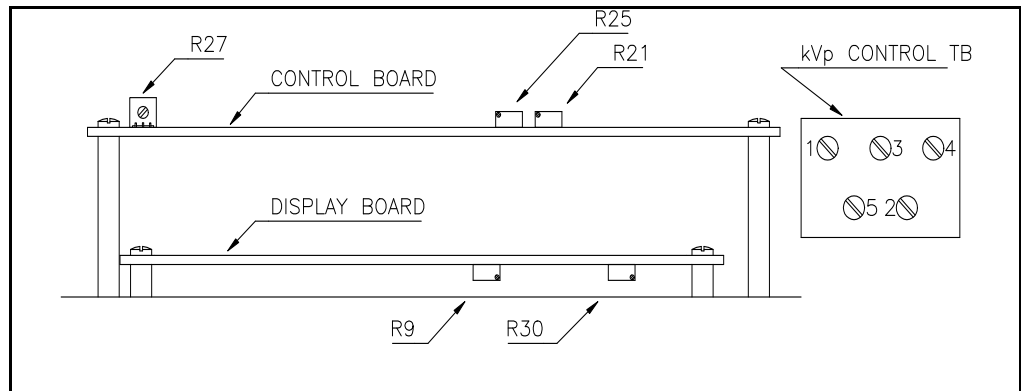

5.2.8 Check battery for option M55.

Locate the battery used for biasing the M55 microfocus X-ray tube. With the DMM measure the voltage across the terminals of the battery.
The battery voltage should be between 8.8 and 9.6 VDC. Replace battery if necessary.

5.2.9 Check and adjust X-ray Tube Current.

The Multi-Test Box (Faxitron part number 43805-69502), shown in Figure 5-1, is used for this test.

With the power turned off and the power cord disconnected from the AC source, connect the Multi-Test Box as follows:

- a.
 1. Unplug system's cable connector P1 from socket connector J1, located on the control circuit board.
 2. Connect the system's cable connector P1 to J1 of the Multi-Test Box (see Figure 5-1).
 3. Connect P1 from the Multi-Test Box to J1 on the control circuit board.
- b.
 1. Unplug system's series cable connector P4/J4, that is located in the cable running between door interlock switch S3 and the HV tube enclosure tank cable harness.
 2. Connect the system's cable connector P4 to J4A of the Multi-Test Box (see Figure 5-1).
 3. Connect P4 from the Multi-Test Box to the system's cable connector J4.

When all the checks in 5.2.9 and 5.2.10, using the Multi-Test box are completed, disconnect the box and restore the original connections.

Checking the X-ray Tube Anode Current.

Due to the nature of this signal, a true RMS meter (the specified DMM) should be used.

Connect the DMM (0-5 VDC) to the "TUBE CURRENT" terminals on the Multi-Test Box.
1 volt = 1 mA.

This check covers the following:

- a. mA bar graph, check and adjustment.
 - b. mA overload trip, check and adjustment.
 - c. mA regulation, check and adjustment.
 - d. mA reference at front panel test point TP1.
- a. mA bar graph, check and adjustment.
1. Allow the unit to warm up for 5 minutes then make a 5 minutes exposure at 50 kVp. Check that the mA is between 2.5 and 3.0 (0.25 and 0.30 with the microfocus X-ray tube). If necessary, adjust the mA ADJUST (R5) shown in Figure 5-13.
 2. Start another exposure still at 50 kVp and set the mA ADJUST to exactly 3.0 (0.3 with a microfocus X-ray tube) read on the DMM.
 3. Check that 8 segments on the mA bar graph are turned on. The number 9 segment is blanked out and number 10 is used to indicate overload.
 4. If number 8 segment is not fully turned on, or if number 10 is flickering, turn mA ADJUST until the DMM indicates 3.20 (0.32 with microfocus tube) then adjust R30 (see Figure 5-12) until number 10 segment starts to flicker.
 5. Turn mA ADJUST back to where the DMM indicates 3.0 (0.3 with the microfocus X-ray tube) and verify that 8 segments on the mA bar graph are turned on.

b. mA overload trip, check and adjustment.

1. If not done so before, allow the unit to warm up for 5 minutes then make a 5 minutes exposure at 50 kVp. Check that the mA is between 2.5 and 3.0 (0.25 and 0.30 with the microfocus X-ray tube). If necessary, adjust the mA ADJUST (R5) shown in Figure 5-13.
2. Start another exposure, still at 50 kVp. While monitoring the mA on the DMM, slowly turn the mA ADJUST until the overload trip comes on and the exposure terminates. Do not, however, exceed 3.6 mA (0.41 mA with the microfocus X-ray tube). Check that the mA, where the overload trip comes on, is between 3.4 and 3.6 mA (0.39 and 0.41 with the microfocus X-ray tube). Also, check that number 10 segment on the mA bar graph is on before the overload trip is activated. Reset mA ADJUST for 3.0 mA (0.3 mA with the microfocus X-ray tube).
3. If the correct value is not obtained, turn the mA ADJUST to 3.5 mA (0.40 with the microfocus X-ray tube) and carefully adjust R27(see Figure 5-12), finding the exact point where the overload trip comes on and the exposure is terminated.

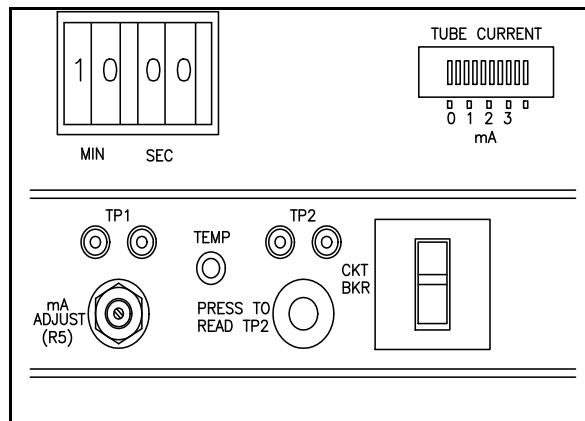

Recheck according to step 2 above.

Reset mA ADJUST for 3.0 mA (0.3 mA with the microfocus X-ray tube).

c. mA regulation, check and adjustment.

1. 1. If not done so before, allow the unit to warm up for 5 minutes then make a 5 minutes exposure at 50 kVp. Check that the mA is between 2.5 and 3.0 (0.25 and 0.30 with the microfocus X-ray tube). If necessary, adjust the mA ADJUST (R5) shown in Figure 5-13.
2. Set kVp to maximum and turn mA ADJUST until 3.0 mA (0.3 mA with the microfocus X-ray tube) is obtained on the DMM.
3. Set kVp to 30 (15 with option M55 microfocus X-ray tube) and check that the mA is not less than 2.5 (0.25 with the microfocus X-ray tube). If adjustment is needed, proceed with the following step.
4. Turn R25 (see Figure 5-12) all the way CCW.
5. Set 50 kVp (25 kVp with microfocus X-ray tube option M55) and turn mA ADJUST to 2.5 mA (0.25 with the microfocus X-ray tube).
6. Turn R25 CW until 3.0 mA (0.3 mA with the microfocus X-ray tube) is obtained. Re-check steps 2 and 3 and if necessary, readjust R25

slightly to optimize the mA regulation.

d. mA reference at front panel test point TP1.

The AC voltage measured at TP1 has a direct relation to the filament current and can be used for troubleshooting without using the Multi-Test Box. To obtain reference values for TP1 proceed as follows:

1. At maximum kVp check that the mA read on the DMM is 3.0 (0.3 with the microfocus X-ray tube). If necessary, adjust the mA ADJUST (R5).
2. At 30 kVp (25 kVp with microfocus tube option M55) check the mA and record the value in Table 5-2.
3. Connect the leads of the DMM to TP1 and check the AC voltage during exposure, with maximum kVp as in step 1. Record the value in Table 5-2.
4. AT 30 kVp(25 kVp with microfocus X-ray tube option M55) check the AC voltage at TP1. Record the value in Table 5-1.

X-ray Tube	kVp	mA	TP1 Reference	TP1 Measured
110 kVp Standard	110	3.0	0.7-1.1	
	30			
130 kVp Option A04	130	3.0	0.7-1.1	
	30			
110 kVp Option M110	110	0.30	1.5-1.8	
	30			
55 kVp Option M55	55	0.30	1.5-1.8	
	25			

Table 5-2. AC Voltage Reference at TP1.

5.2.10 Check HV Transformer Primary Current.

The Multi-Test Box (Faxitron part number 43805-69502), shown in Figure 5-1, is used for this test. It is assumed that the Multi-Test Box is still connected as per steps outlined in paragraph 5.2.9.

Use the true RMS DMM and, during exposure at exposure factors as indicated in Table 5-3, measure the AC voltage at Common - T1 and Common - T2 on the Multi-Test Box. Please note that the AC voltage measured with the Multi-Test Box is equal to the AC current with 1 volt AC = 1 amp. AC.

Also, measure the AC voltage at the front panel TP2. Record the values for future reference in Table 5-3.

X-ray Tube	kVp	mA	Multi-Test Box Reference VAC		Multi-Test Box Measured VAC		Front Panel VAC TP2	
			C-T1	C-T2	C-T1	C-T2	Reference	Measured
Std.	110	3	1.1-1.6	1.2-1.8			1.2-1.8	
Option A04	130	3	1.2-1.9	1.3-2.1			1.3-2.0	
Option M110	110	0.3	0.28-0.30	0.30-0.32			0.29-0.34	
Option M55	55	0.3	0.15-0.25	0.16-0.28			0.16-0.27	

Table 5-3. HV Transformer Primary Current.

5.2.11 Verify proper operation of manual exposure control.

Follow the step by step operating instructions for manual mode operation in section 3 and verify that everything is operating properly. Pay special attention to X-RAY ON lamp and the mA BAR GRAPH METER.

5.2.12 Take standard radiograph and check for satisfactory operation.

Take a standard radiograph of an object for which technique factors are known. Verify that the film is properly exposed and has the expected image quality. Save the film for future reference.

5.2.13 Check and adjust beam locator (Option A02 only).

To check and adjust the beam locator, which is part of the Automatic Exposure Option A02, see Figure 5-14 and assembly drawing in the spare parts section. Then proceed as follows:

- a. Turn system on, but do not press X-RAY START button.
- b. Remove shelf from exposure chamber.
- c. Swing beam locator arm into position and note location of light beam. If beam is on center of floor decal in exposure chamber, no adjustment is necessary.

NOTE: Do not touch any part of the beam locator lamp arm when observing the light beam. There is enough movement in the pivot bearing that pressing down on the short end of the arm will change position of the light beam.

- d. If beam is off from front to rear; loosen knurled nut located near lens housing and slide nut forward or backward until beam is in correct position. Then tighten the knurled nut.

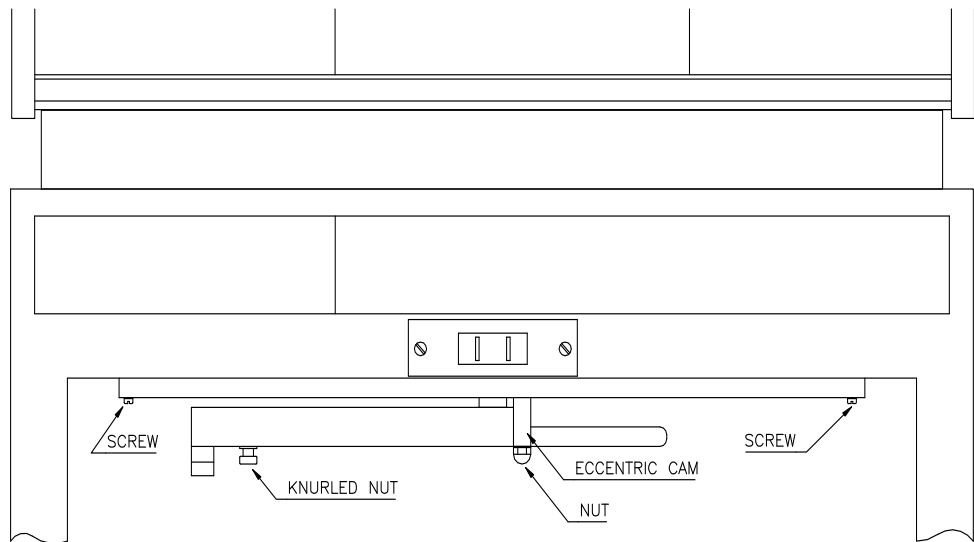

- e. If beam is off to right or left of center; loosen nut, which holds eccentric cam, approximately 3/4 of a turn.
- f. Rotate eccentric cam and note the position of the light beam.
- g. When beam is centered, tighten nut while holding eccentric cam so it does not rotate when nut is tightened.
- h. After beam has been centered, place shelf on floor of exposure chamber. Adjust magnetic shelf holders until sensor is centered with respect to the light beam.

For beam locator lamp replacement, see Disassembly and Repair Instructions.

5.2.14 Check and adjust Auto Exposure Control (A02 option only).

For an explanation of the front panel controls for the AEC, see the operating section of this manual. Also, see the schematic for identification and location of the board components.

Do not make any adjustments, unless the test indicates that the adjustment is outside the tolerance.

a. EXPOSURE PROGRESS bar graph, zero calibration.

1. Place the AUTO/MANUAL switch in AUTO position and allow the unit to warm up for at least 15 minutes.
2. Unplug the sensor from the connector located in lower right rear of the exposure chamber.
3. Set FILM SELECTOR switch to 0 and press the RESET button.
4. Check and confirm that only the second segment (the zero segment) of the EXPOSURE PROGRESS indicator is turned on. There should not be any flickering of the adjacent segments. If this is correct, proceed to step b. If not correct, adjust as follows:
5. Adjust the AUTO ZERO trimmer R24 (located on the AEC display board) until only the number 2 segment is turned on.

b. SENSOR zero calibration.

1. Remove any X-ray filters from the exposure chamber.
2. Set AUTO/MANUAL switch to MANUAL.
3. Verify that the sensor is plugged into the receptacle at the lower right rear of the exposure chamber.
4. Set 30 kVp and 5 minutes and make an exposure for the full 5 minutes.
5. Set FINE ZERO and FINE EXPOSURE controls to the center position.
6. Set FILM SELECTOR to 5.
7. Set the AUTO/MANUAL switch to AUTO.
8. Press RESET and release. Check and confirm that only the second segment (the zero segment) of the EXPOSURE PROGRESS indicator is turned on. There should not be any flickering of the adjacent segments. If this is correct, proceed to step c. If not correct, adjust as follows:
9. Adjust COURSE ZERO ADJUST trimmer R15 until only segment number 2 is on. This trimmer can be reached through an opening in the front panel. See Figure 3-2.
10. Press RESET and repeat the adjustment if necessary.
11. If it is not possible to obtain a correct zero, replace the sensor.

Check and adjust Auto Exposure Control (cont'd)

c. Comparator Calibration.

The comparator amplifier U4 controls the exposure turn-off point which should coincide with the 100% mark on the EXPOSURE PROGRESS bar graph. The calibration can be checked as follows:

1. Make certain that the system is warmed up as indicated in the sensor zero calibration.
2. With the DMM, check the DC voltage between pin 3 of U4 and ground. This voltage should be 2.90 ± 0.05 volts. If it is correct, proceed to sensor gain calibration. If not correct continue to the adjustment in the next step.
3. Adjust Auto Trip Set trimmer R25 until 2.90 ± 0.05 volts is obtained between pin 3 of U4 and ground.

d. Sensor Gain Calibration.

The gain is controlled by the FILM SELECTOR, the FINE EXPOSURE control and the GAIN CALIBRATION control R2. All controls are accessible from the front panel.

The FILM SELECTOR has 6 positions (0 - 5). Position 1 has the lowest gain (or sensitivity). As the sensitivity increases, the exposure time decreases. The relation between film selector positions and exposure time is as shown in Table 5-4.

Film Selector	Exposure Time
1	32
2	16
3	8
4	4
5	2
0	1

Table 5-4. Film Selector vs Exp. Time

Make certain that steps a, b and c above, have been completed. Then proceed as follows:

1. Place the shelf on the lowest position in the chamber, but not resting on the floor. If the system is a dual cabinet or a table system, perform this adjustment in the upper cabinet.
2. Place the calibration sample, delivered with the system, over the sensor window. Please note that there are two different calibration sample. One is made of steel and is delivered with the standard and Option A04 (130 kVp) systems. The other is made of plastic and is delivered with systems using microfocus X-ray tubes, Options M110 and M55. The plastic calibration sample has less attenuation than the steel sample.

Check and adjust Auto Exposure Control (cont'd)

3. Set kVp and FILM SELECTOR, for the appropriate X-ray tube, according to Table 5-5. Be certain that the unit is operating with the correct mA at the selected kVp.
4. Check that the FINE EXPOSURE control is still in the center position.
5. Press RESET and use FINE ZERO control to set zero on the EXPOSURE PROGRESS bar graph.
6. Press X-RAY START. During the exposure, the kVp may drop slightly. Use the kVp CONTROL to maintain specified level.
7. Note the EXPOSURE PROGRESS bar graph. When it reaches 100%, the exposure should terminate.
8. Check the exposure time and confirm that it is according to Table 5-5. If it is correct, proceed to checking response time. If not correct, continue to the adjustment in the next step
9. Adjust GAIN CALIBRATION trimmer R2 reached through an opening in the front panel. See Figure 3-2. Clockwise adjustment decreases time.
10. Repeat steps 5 through 9 until correct calibration is achieved.
11. If it is not possible to obtain correct calibration, replace the sensor.

X-ray Tube	kVp	mA	Film Selector	Exposure Time
Standard and A04 Option	95	3.0	5	2 min. \pm 6 sec.
M110 and M55 Options	20	0.3	1	32 sec. \pm 3 sec.

Table 5-5. Sensor Gain Calibration.

- e. Response Time.
 1. Remove the calibration sample from the top of the sensor.
 2. Press RESET and expose with the settings according to Table 5-5.
 3. Check that unit trips out quickly at 100%. Reject sensor if it does not trip out.

This completes the check and adjust of the Auto Exposure control.

5.2.15 Make Complete Radiation Survey.

A radiation survey should be performed following the steps outlined in section 8 of this manual.

5.2.16 Check that Operating Personnel has Radiation Monitoring System.

Check that the operating personnel has received information about radiation film badge service for cumulative individual personnel monitoring.

5.2.17 Clean Control Panel.

Once a year the control panel and the exterior surface of the system should be cleaned. Use a damp cloth and a water-based solution. Make certain that the unit is turned off and do not allow excess water to penetrate into the unit. Allow plenty of time for any moisture to dry before turning unit on again.

5.2.18 Clean Air Filter.

Once a year, the air filter should be cleaned. The air filter is located on the right side of the wrap around cover.

- a. Remove the filter holder and the foam filter.
- b. Wash the foam filter in hot, soapy water.
- c. Rinse and squeeze out excess water. Then allow filter to dry thoroughly.
- d. Give filter a light coat of a "Filter Coat" (usually available from air conditioning suppliers).
- e. Re-install filter.

5.2.19 Clean Mirror and Fluoroscopy Screen (Fluoroscopy Option A15 only).

Once a year, or whenever dust or particles have accumulated and may interfere with the performance, the mirror and fluoroscopy screen should be cleaned.

Please note that parts of the fluoroscopy options are very delicate and must be handled accordingly. Warm water and soft tissue are recommended for cleaning the plastic -DO NOT USE SOLVENTS. When cleaning the X-ray shielded glass, exercise special care to prevent scratching. Avoid getting oil, fingerprints, etc., on the glass.

The Fluoroscopy Option A15 kit includes a fluorescent screen, a mirror and a lens. The fluorescent screen should not be stored in daylight or in any place where it is exposed to strong light. The mirror is very delicate and should be treated as such. A lens brush may be used to remove dust -DO NOT WIPE WITH CLOTH OR TISSUE. When not in use, the fluoroscopic shelf unit should be stored in a clean, dust-free container.

5.3 DISASSEMBLY AND REPAIR INSTRUCTIONS

WARNING

- **Disconnect input power plug from AC outlet before disassembly.**
- **Do not remove lead radiation shield parts unless absolutely necessary for repairs to the system. If shields are removed, a radiation leakage test must be performed after their replacement.**

Disassembly and repair of this system should be made only by qualified personnel. Because of the danger of introducing hazards, do not install substitute parts or perform any unauthorized modification to the system. Request assistance from Faxitron X-Ray Corporation Sales and Service Office for service and repair to ensure that safety features are maintained.

5.3.1 Fuse Replacement.

There are three fuses, all located on the control circuit board. To check and replace the fuses proceed as follows:

1. Remove the wrap around cover as shown in paragraph 5.1.2.
2. Locate the cover protecting the fuses on the control circuit board.
3. Tilt the cover to expose the fuses.

Note: In units with the 220 V Option A03, there are also two fuses accessible from the back of the unit.

5.3.2 Beam Locator Lamp replacement (A02 Option only).

To replace the lamp in the beam locator, which is part of the Automatic Exposure Option A02, see Figure 5-14 and assembly drawing in the spare parts section. Then proceed as follows:

1. Remove the beam locator assembly from the exposure chamber by disconnecting cable from socket in the rear wall of exposure chamber. Then, with one hand, support the assembly and with the other, remove one screw from each end of the supporting bracket (see Figure 5-14).
2. Lay beam locator on a table and position the arm so lamp is accessible.
3. Remove knurled nut from underside of arm adjacent to lens housing and lift out lamp assembly. Lamp leads are held by friction into lead sockets. To remove, grasp the lead socket gently with long-nose pliers and pull lead socket away from lamp. If power leads are soldered, remove them with a low-wattage soldering iron.
4. Connect the lead sockets to the new lamp in a reversed manner.

CAUTION: Do not bend lamp leads.

5. Position lamp over lens; drop screw into hole in lamp assembly and tighten knurled nut.
6. After beam locator lamp has been replaced, install beam locator in exposure chamber and perform adjustment procedure according to paragraph 5.2.13.

5.3.3 High Voltage Enclosure - Lid Removal.

Replacement of components inside the H.V. Enclosure is a rather involved process and should be carried out, only by persons with proper training and experience in this type of work.

In order to access any of the high voltage components the lid has to be removed. Figure 5-15 and the assembly drawing in the spare parts section shows the major components in the enclosure. To remove the lid proceed as follows:

1. Remove the wrap around cover. See paragraph 5.1.2.
2. Remove 26 bolts securing high voltage enclosure lid.
3. Carefully remove the lid. Note that the enclosure is filled with transformer oil.

CAUTION: Do not allow dirt, dust, water or other contaminants to enter either the H.V. enclosure or the oil.

5.3.4 Draining Transformer Oil from H.V. Enclosure.

To drain the oil from the H.V. enclosure, proceed as follows:

1. Obtain a clean and dry 20 liter (5 gallon) container.
2. Insert a male quick-connect with hose (Faxitron part number 120-101604) into quick-connect on H.V. enclosure and drain oil into the container.

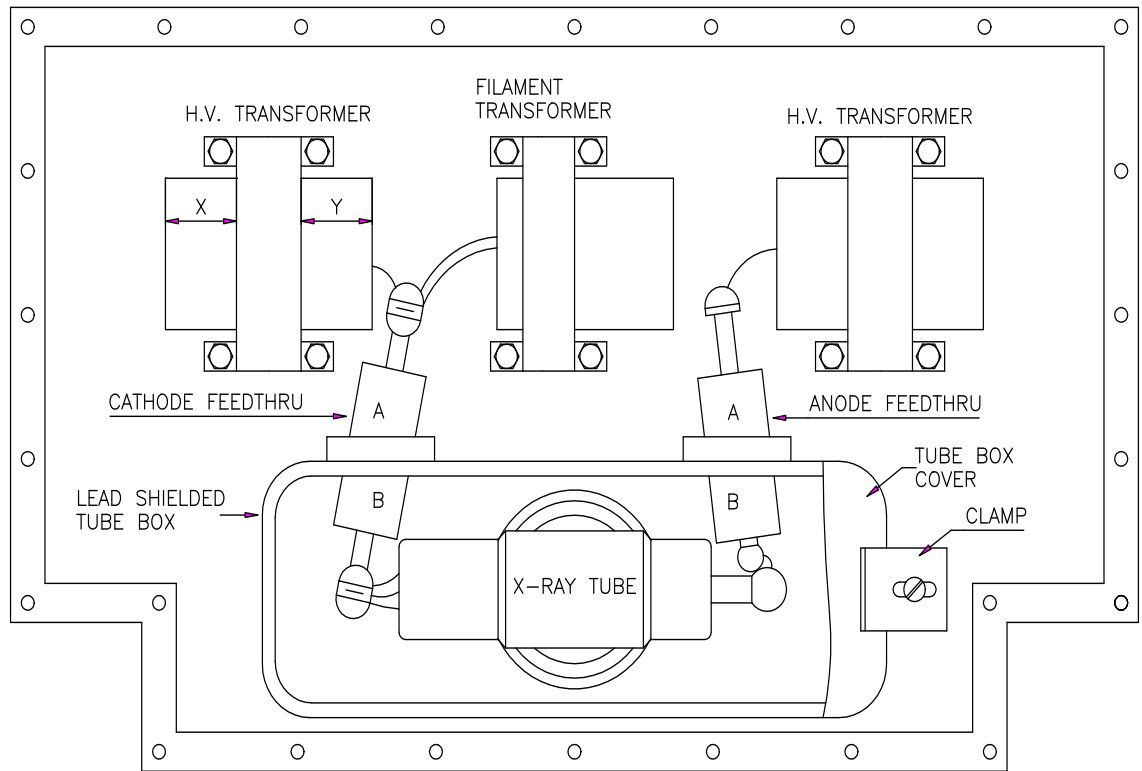

5.3.5 X-ray Tube Replacement (see Figure 5-15).

WARNING

The X-ray tube window is made from Beryllium. When in one piece, there is no hazard with the Beryllium window. However, if broken, the pieces of beryllium can cut the skin. Wounds from Beryllium may not heal without special medical attention - hence should be avoided.

Do not incinerate the old X-ray tube. Beryllium oxide is hazardous to human lungs.

To replace the X-ray tube, proceed as follows:

1. Remove lid for the H.V. enclosure (see 5.3.3) and drain the oil (see 5.3.4).
2. Remove the clamp at each end of the tube box cover and lift off the cover.
3. Using a hex (Allen) wrench, loosen the hex head screws that secures the wires from the X-ray tube to the feedthru fittings and pull out the wires.

CAUTION: Use extreme care in performing the next step. The X-ray tube window could be punctured by the screwdriver.

4. Using a Phillips screwdriver, remove six screws that secure X-ray tube to H.V. enclosure. They are removed by opening compartment door and reaching up to where the X-ray tube window is exposed.
5. Carefully lift X-ray tube out of the enclosure, making certain that all wires are free.
6. To install the new X-ray tube, reverse removal procedure. Use a torque screwdriver with a Phillips drive bit and torque the screws to 1.4 Newton-meter (12 inch-pound). Please note that if a high voltage transformer has to be replaced, it should be done before the new X-ray tube is installed.
7. Fill enclosure with oil (see 5.3.7)

5.3.6 High Voltage Transformer Replacement (see Figure 5-15).

To replace a high voltage transformer, proceed as follows:

1. Remove lid for the H.V. enclosure (see 5.3.3), drain the oil (see 5.3.4) and remove the X-ray tube (see 5.3.5).
2. Make a simple sketch showing how the transformer wires are routed.
3. Using a hex (Allen) wrench, loosen the hex head screws that secures the wires from the transformer to the feedthru fittings and pull out the wires. Unsolder transformer primary leads from the terminal strips.
4. Remove bolts that secure transformer to the enclosure and remove transformer.
5. Remove cathode and anode feedthru from lead shielded tube box and inspect insulation material. Look for "worm holing", "tracking", or any evidence of deterioration. The cathode feedthru has a greater tendency to deteriorate than the anode feedthru; however, both should be carefully inspected.

NOTE: In some models, the transformer (if not already removed) has to be moved in order to slide the cathode feedthru out of the housing.

High Voltage Transformer Replacement (cont'd)

6. If required, replace feedthru. Make certain that the feedthru insulating parts extends the same distance outside and inside the wall of the lead shielded tube box. See Figure 5-15 where A = B.
7. Make certain that all leads on the new X-ray tube and on the new transformer are cut to the same length as on the old one.
8. Install X-ray tube and transformer.
9. Route the leads according to the sketch prepared earlier and connect all leads. For the wires connected to the feedthru, be certain that the wires are pressed close to the "corona balls". This will ensure that the electrical field is kept to a minimum.
10. Make certain that dielectric shields at the top and bottom of the H.V. transformer are equally spaced with reference to the core. See Figure 5-15 where X = Y.
11. Fill enclosure with oil (see 5.3.7).

5.3.7 Filling High Voltage Enclosure with Oil (see Figure 5-15).

When replacing the X-ray tube or the high voltage transformer it is generally recommended to replace the transformer oil. Use Shell Diala AX Transformer Oil.

To fill the high voltage enclosure with oil, proceed as follows:

1. The top lids of the high voltage enclosure as well as the lead shielded tube box, should be removed.
2. Make certain that the interior of the enclosures and the components are clean and free from dust.
3. Slowly pour oil into lead shielded tub box adjacent to the X-ray tube until oil level reaches upper ledge. Avoid causing any bubbles in oil.
4. Using a piece of wire, work any bubbles out.
5. Install the tube box cover and tighten the two hold down clamps.
6. Continue to fill the high voltage enclosure to within 6 mm (1/4") of the top.
7. Check the seal which covers the lower surface of the top lid for the high voltage enclosure.
8. Install the top lid on the high voltage enclosure and tighten all 26 bolts.
9. Using the bottom quick-connect, drain approximately 1 liter (1/4 of a gallon) of oil from the enclosure.
10. Install the wrap around cover and any other items removed earlier.
11. Warm up the unit very slowly and re-calibrate it.

5.4 TROUBLESHOOTING

5.4.1 Troubleshooting the Display Section (see display board schematic and Figure 3-1)

SYMPTOM	CHECK/ADJUST
One or more digits of TIME DISPLAY does not light.	Check TIME DISPLAY. Check display driver chip U1.
One or more digits of kVp METER display does not light.	Check kVp METER display. Check display driver chip U3.
One digit of TIME DISPLAY will not preset correctly.	Check TIME SET THUMBWHEELS assembly. Check preset diodes CR1 thru CR14. Check display driver chip U1.
Time preset but will not count.	Check voltage at pin 9 of U11 count enable. Check CR15, CR16, R21, R33, R29, R24, C9, U12, Q1 and U15.
Timer counts down, but will not time out.	Check display driver chip U1. Check latch U15. Check U8, Q1 and K2 on the Control Board.
No TUBE CURRENT display. X-RAY ON lamp on, feedback voltage is OK.	Check bar graph driver U13. Check bar graph display DS8, R2 and R3.
X-ray tube current measures correctly 3 or 0.3 mA but TUBE CURRENT bar graph reads high or low.	Check and adjust according to paragraph 5.2.9.
TIME DISPLAY does not blank at power ON.	Check reset circuit Q1 and R12. Check Auto RESET SWITCH on the display panel of the AEC option A02. Check flat cable and connectors.

5.4.2 Troubleshooting the Auto Expose Section (Option A02 only).

See Auto Expose Board Schematic and Figure 3-2.

SYMPTOM	CHECK/ADJUST
EXPOSURE PROGRESS display does not show any movement. X-RAY ON lamp and tube current display O.K.	Sensor not plugged in.
Exposure does not shut off when EXPOSURE PROGRESS display indicates 100%. Will trip for high film switch number. EXPOSURE PROGRESS display remains on in manual mode.	Check and adjust according to paragraph 5.2.14. Check + and - on the 6.8 V supplies.
Sensor does not reset. Beam locator does not light. EXPOSURE PROGRESS display does not light.	Check fuse F3 on the Control Board.
Sensor will not reset. Beam locator and EXPOSURE PROGRESS indicator lights O.K.	Defective sensor. Defective cable.

5.4.3 Troubleshooting the X-ray Generator Section.

See Control Board Schematic.

SYMPTOM	CHECK/ADJUST
Fuse blows or circuit breaker trips.	X-ray tube is defective (gassy). Voltage breakdown in H.V. transformer. Voltage breakdown in filament transformer. Voltage breakdown in H.V. feedthrus.
X-RAY ON light comes on, but no tube current indicated.	Fuse F1. Relay K1. Defective X-ray tube.
X-ray tube current low.	Check TP-1 for change in reading when X-RAY START light comes on. If reading does not change, relay contacts may not short out the 200 ohm resistor R3 in the filament circuit. Replace relay K1.

SECTION 6
SCHEMATICS

CONTENTS	PAGE
System Block Diagram.....	6.1
Control Board.....	6.2
Display Board	6.3
Auto Expose Board.....	6.4
Cable Interconnect.....	6.5

SECTION 7
PART LIST

CONTENTS	PAGE
Ordering Information	7.1
Control Unit and H.V Enclosure	7.2
Cabinet Unit, Exterior and Shelf.....	7.3
Cabinet Unit, Interior.....	7.4
Control Unit, Front Panel	7.5
Control Unit, Interior.....	7.6
PC Control Board.....	7.7
PC Display Board	7.8
PC Auto Expose Board (AEC option A02 only).....	7.9
Tube Enclosure.....	7.10
Beam Locator Assembly (AEC option A02 only).....	7.11
Door (Fluoroscopic option A15 only).....	7.12
Adapting Transformer Kit for 220 V, 50 HZ (Option A03 only).....	7.13
Table, Model 43856A.....	7.14

SECTION 7

PART LIST

ORDERING INFORMATION.

To order a replacement part, send order to or call your authorized Faxitron X-Ray Corporation Sales/Service office.

Specify the following information:

1. Model number and complete serial number of the system.
2. Faxitron X-Ray Corporation part number.
3. For electrical components, please give circuit reference number (R1, C1 T1 etc.)
4. Description.

To order part not listed, give a complete description of the part and include its function and location.

Please note that service should be carried out by qualified personnel only. Replacement of parts may require recalibration using special instruments. See section 5 of the manual.

PART LIST (cont'd)

CONTROL UNIT AND H.V. ENCLOSURE

ITEM NO.	DESCRIPTION	QTY	MANUFACTURER	MFG PART NO/SPEC.	FAXITRON PART NO.
1a	Control Unit, Compl. Manual	1	Faxitron	43805-65100	43805-65100
1b	Control Unit, Compl. Auto Exp.	1	Faxitron	43805-65000	43805-65000
2a	Tube Enclosure, 110 kVp Std.	1	Faxitron	43805-60100	43805-60100
2b	Tube Enclosure, 55 kVp, MF	1	Faxitron	43805-60050	43805-60050
2c	Tube Enclosure, 110 kVp, MF	1	Faxitron	43805-60051	43805-60051
2d	Tube Enclosure, 130 kVp	1	Faxitron	43805-60102	43805-60102
2e	Tube Enclosure, 150 kVp	1	Faxitron	43805-60052F	43805-60052F
2f	Tube Enclosure, 130 kVp	1	Faxitron	43805-60055	43805-60055
3	Shroud	1	Faxitron	43805-04110	43805-04110
4	Foam Filter	1	Faxitron	100-804533	100-804533
5	Filter Holder Assembly	1	Faxitron	120-804509	120-804509
6	Fan, Tubeaxial	1	Faxitron	3160-0361	3160-0361
7	Rad. Shield Cone	1	Faxitron	100-804277	100-804277

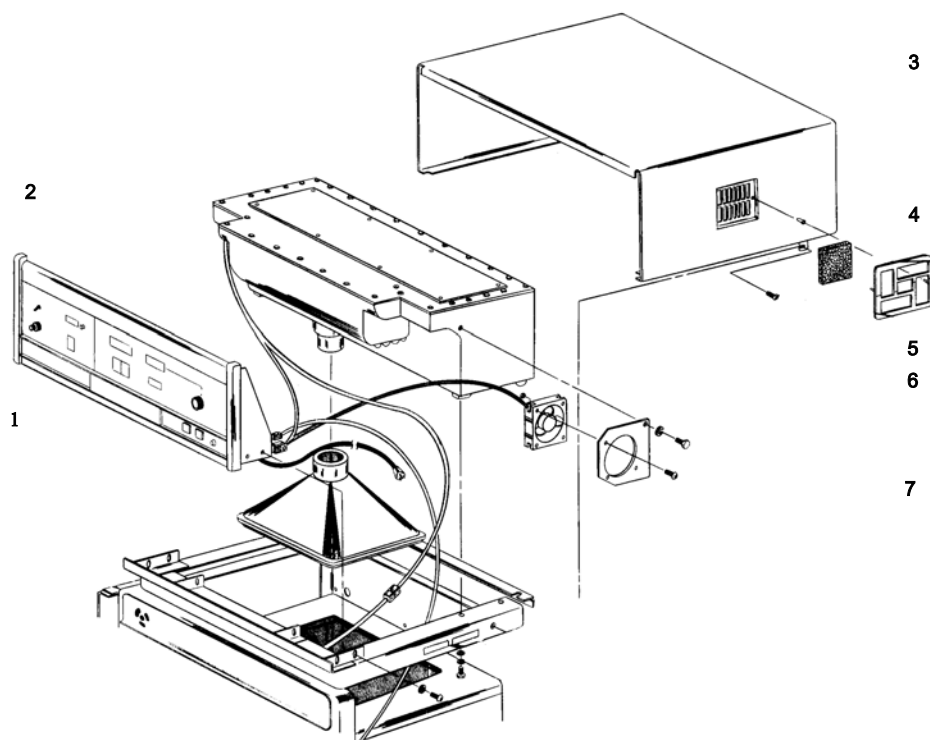

PART LIST (cont'd)

CABINET UNIT EXTERIOR AND SHELF

ITEM NO.	DESCRIPTION	QTY	MANUFACTURER	MFG PART NO/SPEC.	FAXITRON PART NO.
1	Side Panel	2	Faxitron	43805-00212	43805-00212
2a	Shelf Assembly, Standard	1	Faxitron	120-804012	120-804012
2b	Shelf Assembly, Auto Exp.	1	Faxitron	120-805008	120-805008
2c	Shelf, 1/4", M55 & M110.	1	Faxitron	NA071894-02	NA071894-02
2d	Shelf Overlay, M55 & M110	1	Faxitron	120-04013F	120-04013F
3	Sensor Assy.(Auto Exp. Only)	1	Faxitron	43805-69530	43805-69530

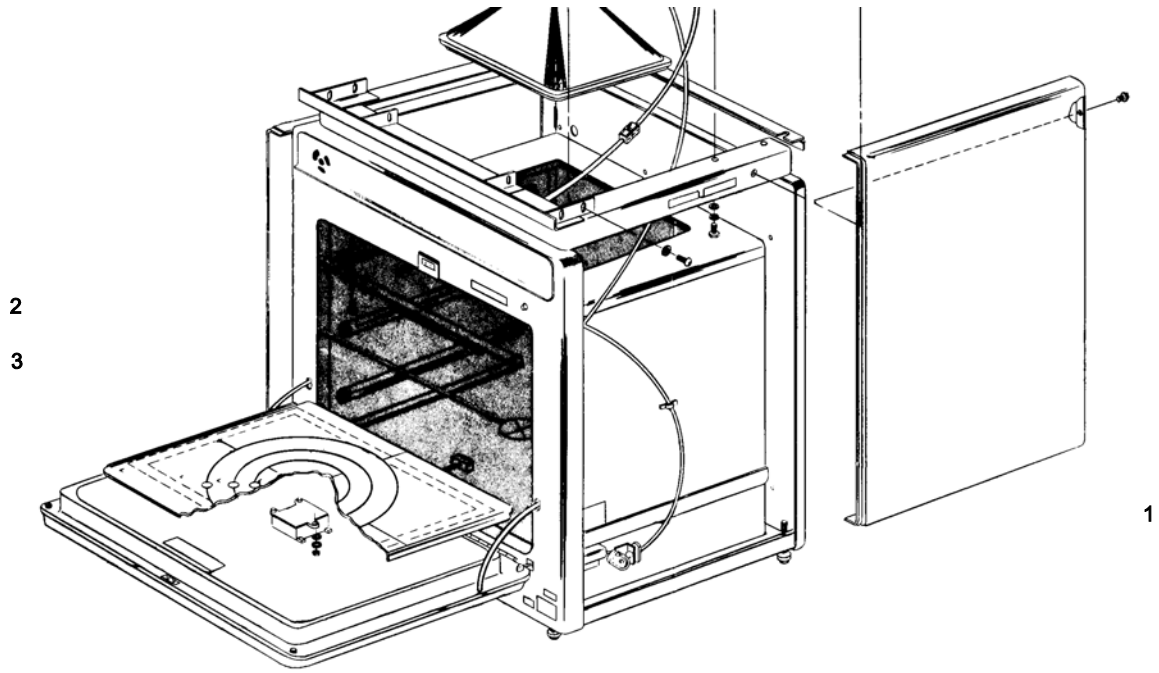

PART LIST (cont'd)

CABINET UNIT, INTERIOR

ITEM NO.	DESCRIPTION	QTY	MANUFACTURER	MFG PART NO/SPEC.	FAXITRON PART NO.
1	Plug-Switch	1	Faxitron	5040-9101	5040-9101
2	Plate Switch	1	Faxitron	43805-04105	43805-04105
3	Bracket Interlock	1	Faxitron	43805-01207	43805-01207
4	Recept. AY Interlock	1	Faxitron	43805-69501	43805-69501
5	Microswitch	1	Honeywell	BZ-2RS-A2	3101-1988
6	Hex Nut 5/16-18	2			2950-0101
7	Compression Spring	2	Faxitron	100-804733	100-804733
8	Switch	1	Carlingswitch	Type 170, 15A, 125VAC, SPNC	3101-2000
9	Switch Cover	1	Faxitron	100-804744	100-804744
10	Cabinet Feet	4	Hardware Speciality	FE2724	0403-0334

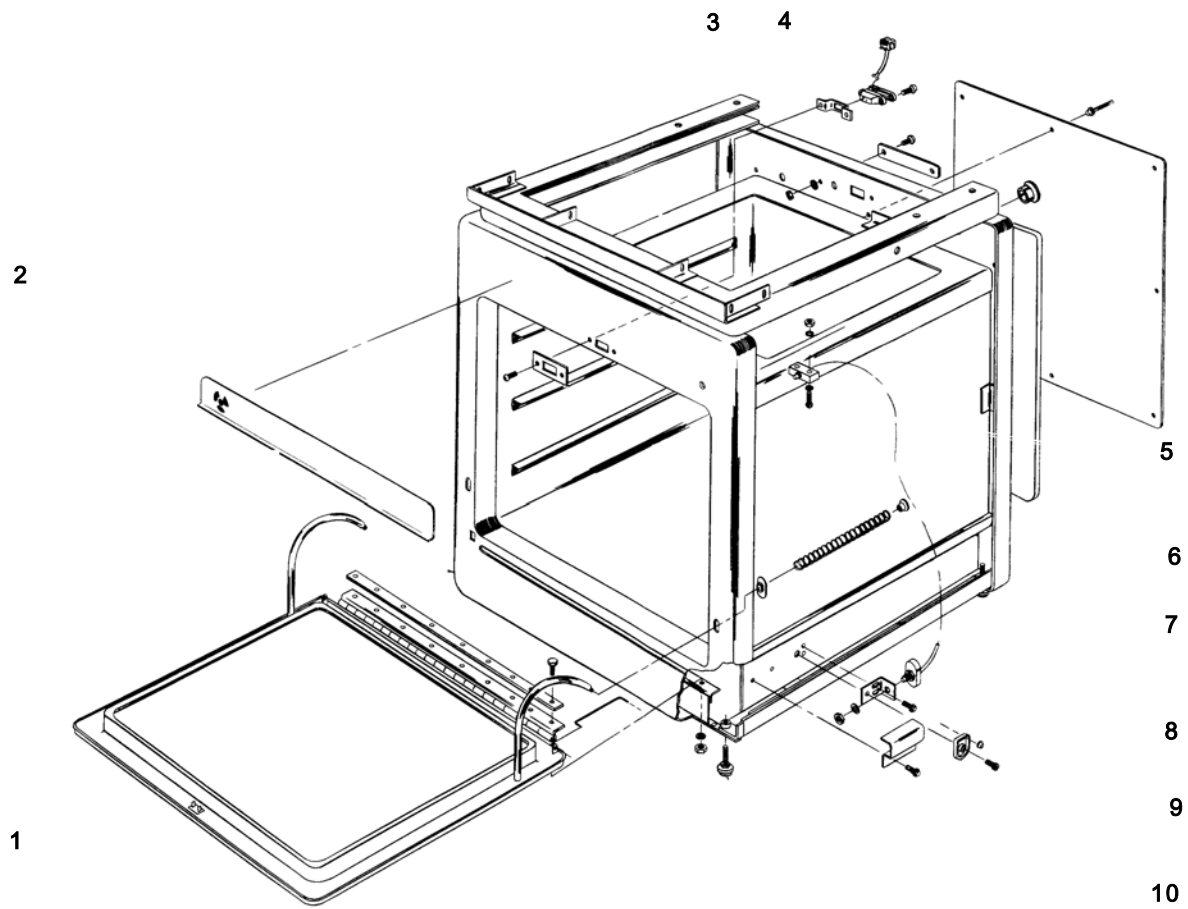

PART LIST (cont'd)

CONTROL UNIT, FRONT PANEL

ITEM NO.	DESCRIPTION	QTY	MANUFACTURER	MFG PART NO/SPEC.	FAXITRON PART NO.
1	Switch-Thumbwheel	1	Interswitch Inc.	ISO-2065	3100-1697
2	Knob-kVp Control	1	Cosmo Plastic		0370-3118
3	Side Molding	2	Faxitron	4040-1016	4040-1016
4a	Keylock Switch	1	C & K	8370K150	3101-1851
4b	Extra Key for Keylock Switch	1	Arrow Hart	81715-L	3131-0372
5a	Pushbutton Switch	2	CRL/Dialco	513-0311-001	3101-2659
5b	Lamp, 6V, 0.2A	2	GE	328	2140-0039
5c	Lens Cap, Red, Screened	1	Faxitron	1450-0544	1450-0544
6	Lens Cap, Green	1	CRL/Dialco	187-1872	3131-0472
7	Circuit Breaker	1	Airpax Corp.	R21-4-7.5A-B01CV	3105-0177
8	Pushbutton Switch	1	C & K/Unimax	2LJ6-2C	3101-0172
The following parts are used for the Auto Expose Control Option A02 only					
9	Switch-Thumbwheel	1	Interswitch Inc.	ISO-2066	3100-1698
10a	Knob, Fine Exposure (small)	1	Cosmo Plastics		0370-3125
10b	Knob, Fine Zero (large)	1	Cosmo Plastics		0370-3119
11	Toggle Switch	1	C & K	U21-P3Y1V80QE/7099	3101-2688
12	Switch, PB, Snap	1	C & K	U821YV80GE W/7099-01-264	3101-2689

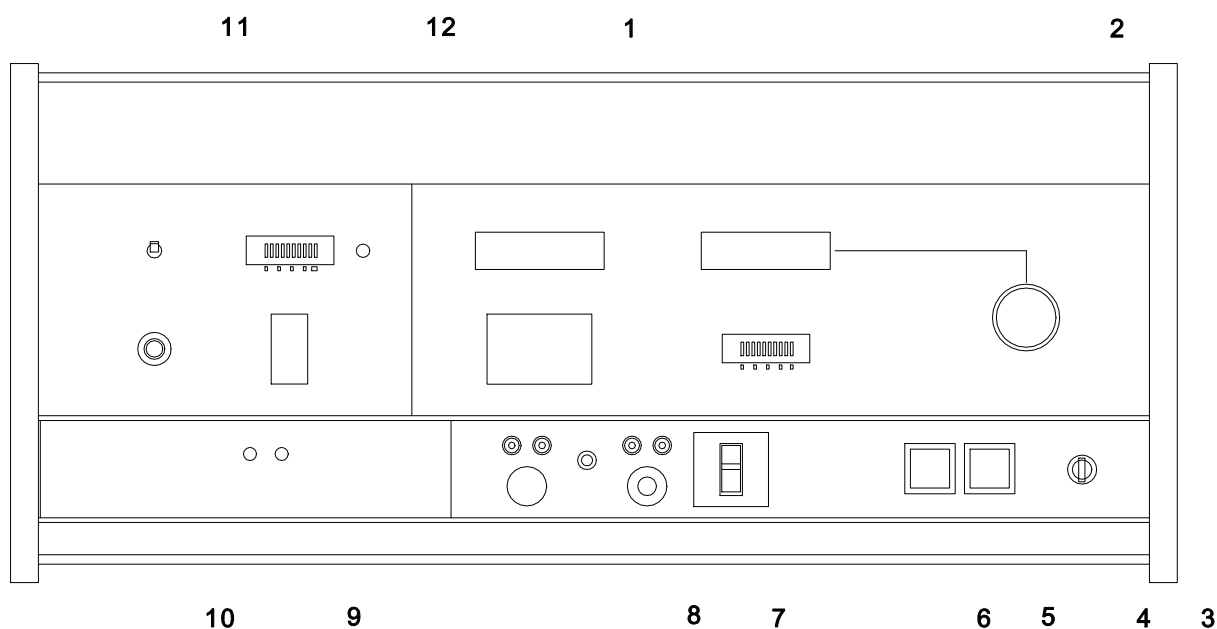

PART LIST (cont'd)

CONTROL UNIT, INTERIOR

ITEM NO.	DESCRIPTION	QTY	MANUFACTURER	MFG PART NO/SPEC.	FAXITRON PART NO.
1	Transformer (T2)	1	Allied Elec.	6K32HF	9100-3530
2	Variable Transformer	1	Superior Electric	Type 21, 120V in, 0-140V out	9100-3537
3	PC AY Control Board	1	Faxitron	43805-60103	43805-
4	PC AY Display Board	1	Faxitron	43805-60110	43805-
The following parts are used for the Auto Expose Control Option A02 only					
5	PC AY Auto Expose Board	1	Faxitron	43805-60107	43805-
6	Transformer (T5)	1	MagneTek Triad	Type F-91X, 120/10-20CT-	9100-3533

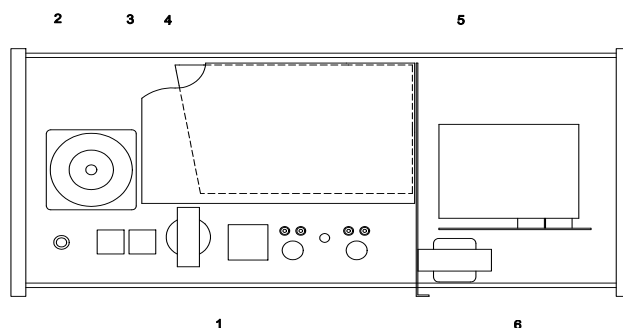

PART LIST (cont'd)

PC CONTROL BOARD 43805-60103

ITEM NO.	DESCRIPTION	QTY	MANUFACTURER	MFG PART NO/SPEC.	FAXITRON PART NO.
1	PC AY Control Board Complete	1	Faxitron	43805-60103	43805-60103
2	Fuse 0.25A 250V	1	Cooper Ind.	MDL-1/4	2110-0201
3	Fuse 0.75A 250V	1	Littlefuse Inc.	313.750	2110-0360
4	Fuse 8A 250V	1	Cooper Ind.	ABC-8	2110-0342
5	LED Lamp Green	3	Hewlett Packard	HLMP-1503	1990-0485
6	Relay, 2C 5VDC 0.5A	1	NEC Electronic	MR22-5US	0490-1190
7	IC, +5V Regulator	1	Motorola	MC7805CT	1826-0122
8	IC, -12V Regulator	1	Motorola	MC7912CT	1826-0221
9	IC, +12V Regulator	1	Motorola	MC7812CT	1826-0147
10	Relay, 120VAC 10A	1	Potter Brumfield Inc.	KUP-14A15-120V	0490-0540

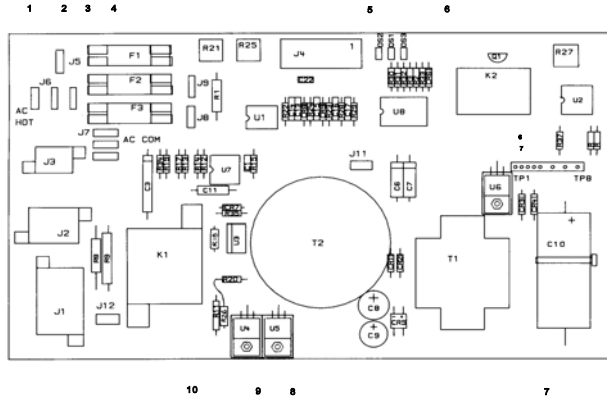

PART LIST (cont'd)

PC DISPLAY BOARD 43805-60110

ITEM NO.	DESCRIPTION	QTY	MANUFACTURER	MFG PART NO/SPEC.	FAXITRON PART NO.
1	PC AY Display Board Complete	1	Faxitron	43805-60110	43805-60110
2	Junction Display	4	Hewlett Packard	HDSP-3733	1990-0894
3	IC Voltage Regulator	1	Motorola	MC79L05ACP	1826-0285
4	Numeric Display	3	Hewlett Packard	HDSP-3731	1990-0714

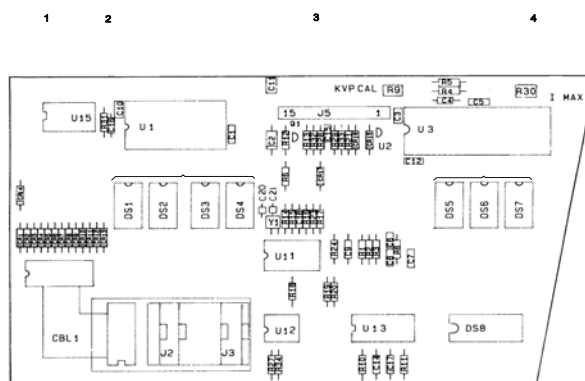

PART LIST (cont'd)

PC AUTO EXPOSE BOARD 43805-60107

ITEM NO.	DESCRIPTION	QTY	MANUFACTURER	MFG PART NO/SPEC.	FAXITRON PART NO.
1	PC Auto Expose Board Cpl.	1	Faxitron	43805-60107	43895-60107

1

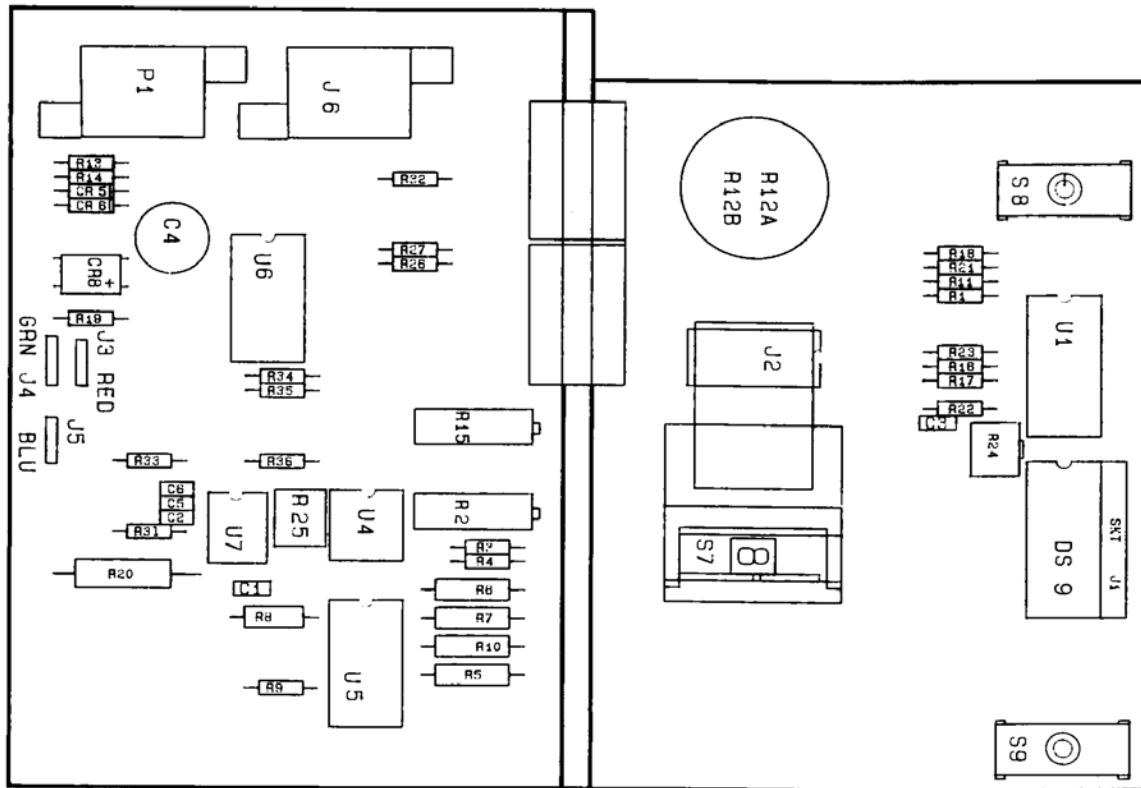

PART LIST (cont'd)

TUBE ENCLOSURE

ITEM NO.	DESCRIPTION	QTY	MANUFACTURER	MFG PART NO/SPEC.	FAXITRON PART NO.
1a	Tube Enclosure, 110 kVp Std.	1	Faxitron	43805-60100	43805-60100
1b	Tube Enclosure, 55 kVp, MF	1	Faxitron	43805-60050	43805-60050
1c	Tube Enclosure, 110 kVp, MF	1	Faxitron	43805-60051	43805-60051
1d	Tube Enclosure, 130 kVp	1	Faxitron	43805-60102	43805-60102
1e	Tube Enclosure, 150 kVp	1	Faxitron	43805-60052F	43805-60052F
2a	Filament Transformer 130 kVp	1	Faxitron	120-427915	120-427915
2b	Filament Transformer 150 kVp	1	Faxitron	120-427918	120-427918
3a	H.V. Transformer 110 kVp	2*	Faxitron	120-427908	120-427908
3b	H.V. Transformer 130 kVp	2	Faxitron	120-427917	120-427917
3c	H.V. Transformer 150 kVp	2	Faxitron	120-427919	120-427919
4a	X-ray Tube, 110 kVp Std.	1	Faxitron	130-552003	130-552003
4b	X-ray Tube, 55 kVp, MF	1	Faxitron	130-552001	130-552001
4c	X-ray Tube, 110 kVp, MF	1	Faxitron	130-552002	130-552002
4d	X-ray Tube, 130 kVp	1	Faxitron	130-552000	130-552000
4e	X-ray Tube, 150 kVp	1	Faxitron	15-0018-01	15-0018-01
5	Gasket	1	Faxitron	100-804356	100-804356

* Only one(1) H.V. Transformer used in 55 kVp, MF Tube Enclosure

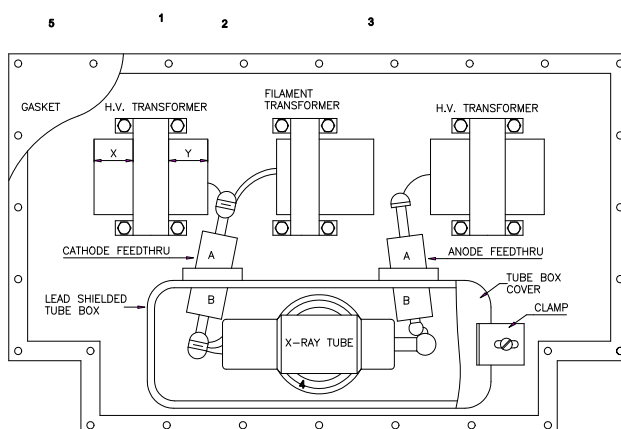

PART LIST (cont'd)

BEAM LOCATOR ASSEMBLY 120-805020

ITEM NO.	DESCRIPTION	QTY	MANUFACTURER	MFG PART NO/SPEC.	FAXITRON PART NO.
1	Beam Locator Ass. Complete	1	Faxitron	120-805020	120-805020
2	Lamp Assembly	1	Faxitron	120-805014	120-805014

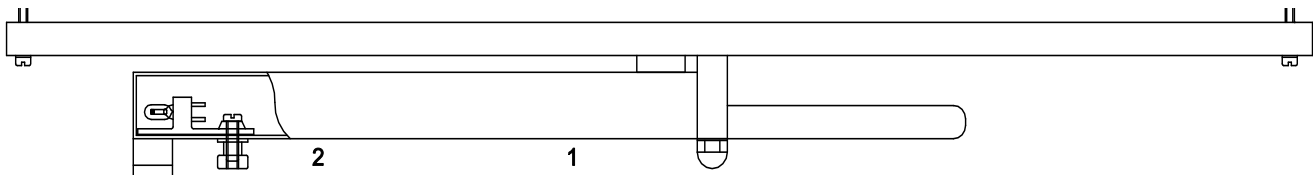

PART LIST (cont'd)

DOOR, FLUOROSCOPIC OPTION A15

ITEM NO.	DESCRIPTION	QTY	MANUFACTURER	MFG PART NO/SPEC.	FAXITRON PART NO.
1	Bezel, Fluoro Viewer	1	Faxitron	100-351021	100-351021
2	Lead Glass	2	Faxitron	43351-29300	43351-29300
3	Viewer Hood	1	Faxitron	9301-0329	9301-0329

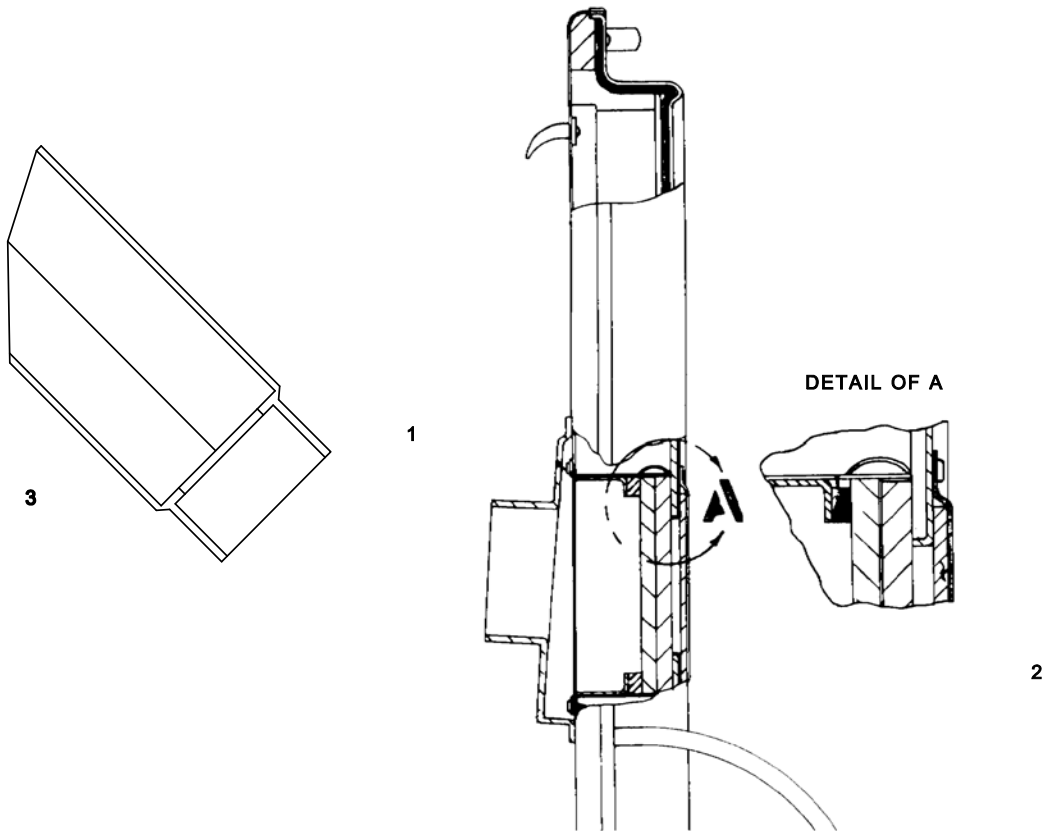

PART LIST (cont'd)

ADAPTING TRANSFORMER KIT FOR 220 V, 50 HZ, OPTION A03

ITEM NO.	DESCRIPTION	QTY	MANUFACTURER	MFG PART NO/SPEC.	FAXITRON PART NO.
1	Fuse Holder	2	Schroeder	031.1657	2110-0564
2	Fuse	2	Schroeder	001.2511/T5AH	2110-0796
3	Fuse Holder Cap	2	Schroeder	031.1663	2110-0567
4	Connector, AC Power	1	Switchcraft	EAC3093	1251-2357
5	Transformer	1	Faxitron	9100-3972	9100-3972
6	Terminal Block	1	Cinch	354-11-06-001/ 2A, 250V	0360-1134
7	Terminal Block	1	Cinch	353-21-02-001/ 15A, 600V	0360-0651

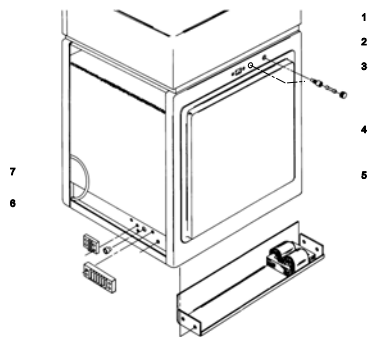

PART LIST (cont'd)

TABLE, MODEL 43856A

ITEM NO.	DESCRIPTION	QTY	MANUFACTURER	MFG PART NO/SPEC.	FAXITRON PART NO.
1	Switch	1	Carlingswitch	Type 170, 15A, 125VAC, SPNC	3101-2000
2	Microswitch	1	Honeywell	BZ-2RS-A2	3101-1988

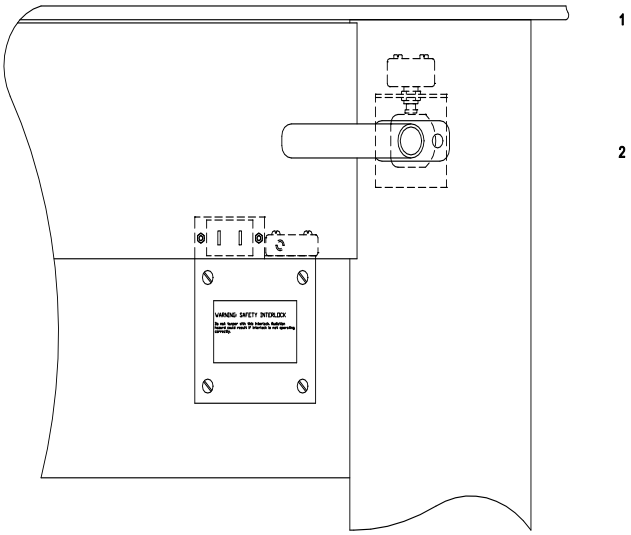

SECTION 8
RADIATION SURVEY

CONTENTS	PAGE
8.1 Radiation Safety Standard.....	8.1
8.2 Measuring Instrument Check - Before Survey.....	8.1
8.3 Surveying Cabinet System	8.1
8.4 Dual Cabinet System.....	8.2
8.5 Table System	8.2
8.6 Measuring Instrument Check - After Survey.....	8.2

SECTION 8
RADIATION SURVEY

8.1 RADIATION SAFETY STANDARD.

- a. For systems delivered to all countries except UK:
Less than 0.5 mR/hr at 5 cm (2 in.) from exterior surface at maximum kVp.
- b. For systems delivered to UK:
Less than 0.1 mR/hr at 10 cm (4 in.) from exterior surface at maximum kVp.

8.2 MEASURING INSTRUMENT CHECK - BEFORE SURVEY.

- a. Type of instrument:
The Victoreen 450 P or equivalent with an accurate reading at 0.5 mR/hr is recommended.
- b. Calibration date:
Make certain that the survey meter has been calibrated within the last three months.
- c. Battery Check:
Check for proper battery condition. Replace batteries before survey if required.
- d. Operational source check:
If the survey meter has a source check, check it as instructed in the operators manual for the meter.
- e. All measurements should be made with the beta cap removed.

8.3 SURVEYING CABINET SYSTEM

- a. Place a shelf at the 18" SID level and a 4 liter (1 gallon) plastic jug of water on the center of the shelf. Make certain there is no filtration (filter is in the filter holder, etc.) in the direct beam.
- b. Block or wedge the door open to a point just before the interlock actuates.
- c. Set kVp to maximum and expose at 3 mA for standard and option A04 systems, 0.3 mA for options M110 and M55 systems.
- d. Starting around the door slowly scan the four sides and top of the system. Scan at about 4 cm/second (about 1.6"/second) across each side at about 2 to 2.5 cm (0.8 to 1") from face of survey meter to face of side or top of the system. Scans are made in horizontal movements from one edge of face to the other edge, moving down an average of 5 cm (2") each pass. Scan in a parallel line back and forth until the whole side is scanned.

Perimeter of sides are then scanned. If there is an increase while scanning, in meter reading, by leakage, or by background burst of radiation, the area of approximately 5 x 5 cm (2 x 2") shall be very slowly scanned. Go over the area two or three times until there is a stabilized reading on the meter. The highest stabilized reading (HR) is recorded for all four sides and for the top of the system.
- e. Determine the lowest value of background radiation, by turning the X-ray system off and waiting for the meter to stabilize to its lowest level (BG). Record this value. Actual (net) leakage values are determined by the formula:

$$\text{Actual Leakage} = \text{HR} - \text{BG}$$

SURVEYING CABINET SYSTEM (cont'd)

NOTE: In order to obtain the reading for the top of the system, the meter was held vertically. Be certain to measure the corresponding background reading with the meter held vertically.

- f. If the system is on a table, or if there is personnel on the floor below where the system is used, the bottom of the unit should also be surveyed. Before scanning the bottom of the cabinet, all attenuation in the direct beam, such as the water jug, metal shelf, filters, etc., shall be removed.

NOTE: In order to obtain the reading for the bottom of the system, the meter was held vertically. Be certain to measure the corresponding background reading with the meter held vertically.

- g. When the system is placed against a wall and people occupy an area on the other side of the wall - be certain to survey the area immediately on the other side of the wall in a similar manner as specified in step d.

8. 4 DUAL CABINET SYSTEM, 43855B.

Repeat steps a - e for the lower cabinet.

8. 5 TABLE SYSTEM, 43856A.

Place the water jug on the bottom of the drawer, and repeat steps a - e measuring on the table.

8. 6 MEASURING INSTRUMENT CHECK - AFTER SURVEY.

- a. Battery Check:

Check for proper battery condition. If battery condition is not correct, replace batteries and repeat the survey.

- b. Operational source check:

If the survey meter has a source check, check it as instructed in the operators manual for the meter. If the reading is out of specification, all readings made during the survey could be incorrect. Recalibrate or replace the survey instrument and repeat the survey.

SECTION 9
MAINTENANCE SCHEDULE

9.1 SAFETY PRODUCT ASSURANCE CHECKS, EVERY SIXTH MONTH.

For a complete description of the procedure, see the listed paragraphs in section 5.

Paragraph	Procedure	Date	Date	Date
5.2.1	Decals and operator safety instructions in place			
5.2.2	Resistance from cabinet to input power cord ground pin			
5.2.3	Resistance from line and neutral to ground			
5.2.4	Proper power receptacle/connector polarity			
5.2.5	Adjustment of compartment/drawer interlocks			
5.2.6	Zero of TUBE CURRENT and kVp METERS			
5.2.7	kVp METER			
5.2.8	Battery for option M55			
5.2.9	X-ray tube current			
5.2.10	HV transformer primary current			
5.2.11	Proper operation of manual exposure control			
5.2.12	Take standard radiograph and check for satisfactory operation			
5.2.13	Beam locator (Option A02 only)			
5.2.14	Auto exposure control (Option A02 only)			
5.2.15	Make radiation survey			
5.2.16	Operating personnel has radiation monitoring system			

Checked by	Date	comments

Additional Comments:

.....

.....

.....

.....
.....