

2015 Conference on Emerging Energy and Process Technology (CONCEPT2015)
15-16 December 2015, A' Famosa Resort, Alor Gajah, Melaka

A Hybrid Renewable Energy System for a Longhouse

Wen-Shan Tan¹ and Mohamed Shaaban¹

¹ Centre of Electrical Energy Systems (CEES)

Institute of Future Energy (IFE) and Faculty of Electrical Engineering (FKE)

Universiti Teknologi Malaysia (UTM)

81310 Johor Bahru, Malaysia

Email: wstan6@live.utm.my, m.shaaban@fke.utm.my

ABSTRACT

Renewable energy resources have already become an important alternative electric power generation technologies, due to the negative impacts of global warming on the environment, brought about by the use of fossil-fuelled generation. To combat such impacts, a hybrid energy system which consists of more than one source of renewable energy would be a good alternative to replace conventional electricity generation for Malaysia's rural areas. A longhouse, or 'Rumah Panjang' in the local language, is a timber house raised three to five feet off the ground on stilts. Between 20 – 40 families of the 'Rungus', an ethnic group in the Borneo, residing primarily in northern Sabah, in the area around Kudat, dwell these longhouses. Due to the limitation of electricity access in that area, a hybrid system that consists of solar and wind energies as well as energy storage is proposed as a standalone renewable energy system for electricity supply. In this paper, three load profiles, representing various weather conditions; including hot, rainy and normal weather days are developed to represent the annual load curve. Meteorological data of solar irradiation and wind speed are collected at the Kudat area. Modelling of the hybrid system is then carried out based on selecting the most suitable system components, such as PV arrays, wind turbines, batteries and the inverter that satisfy both the technical and financial feasibility criteria. The model is then simulated using HOMER software to calculate the net present cost and the levelized cost of energy (LCOE). Results of the hybrid system simulation are compared with a diesel power generation, representing conventional energy supply, as the existing energy source. The comparison highlights the economic viability of the proposed hybrid system as a sustainable energy alternative to supply electricity to the longhouse.

Key Words: Hybrid power system, renewable energy resources, optimization.

1. INTRODUCTION

The world mainly consists of three major energy sources: fossil fuels, nuclear and renewable energy sources [1]. Fossil fuel will continually remain as the major source of power generation in the world, as well as in Malaysia [2]. However, there are a number of negatives impacts by use of fossil-fuelled generation, such as acid rain, ozone layer depletion and global climate change [3]. A renewable energy resource is defined as a sustainable resource available at a reasonable cost that can be regenerated or replenished for fulfilling the load demand without causing negative impacts to the environment. Renewable resource is also expressed as clean energy source and optimal use of these resources in power system could minimize the environmental impacts with the reduction in greenhouse gases emission, which is a major factor of global warming [4]. An integrated hybrid power system is a power generation system which consists of multiple electricity generating

components. In this paper, two types of renewable energy resources is chosen, which are solar and wind generation to supply the hybrid power system.

The Rungus, an ethic tribe of northern Borneo, is a group of people who resides in the northern Sabah, Malaysia, an area named Kudat. The Rungus settle themselves in a longhouse which provides shelter for up to 20-40 families where each family will have its own apartment while sharing a common living area [5, 6]. Most of these longhouses are located far from the town and reside in the inner part of the jungle. Rural electrification is the process of bringing electrical power to rural and remote areas. The difficulty to extend grid connection through the thick jungle and associate transmission loss cause the grid power supply in rural area not feasible and economic. Renewable energy could supply the rural power demand without the consideration of the transmission cost from the grid. Malaysia is an equatorial country which has abundant potential for renewable energy resources [3], while Kudat which located in the northern part of Sabah possess the high potential for solar and wind. An integrated hybrid power system consists of solar, wind and energy storage, would be suitable as the off-grid power generation as it exhibits higher reliability and reduces the operation cost significantly than those system with only one energy source, such as a diesel generation only off-grid power system [3].

In the literature, a few optimization techniques have been utilized for hybrid system sizing and modelling, such as graphical construction [7], artificial intelligence [8], dynamic programming [9], linear programming [10], multi-objective design [11], and iterative approach [10, 12]. In this paper, Homer, a micro-grid analysis tool, is chosen to perform the hybrid system modelling and optimization, to model a technical and economical feasible hybrid system.

2. MODELLING OF THE HYBRID POWER SYSTEM

Two analysis techniques are employed in this project, which are technical analysis and financial analysis. These analyses are implemented with the aim to find out the most feasible hybrid system model for the longhouses in Kudat, Sabah. Figure 1 shows the procedures in designing an integrated hybrid power system, which includes the load profile development, the solar and wind data resources acquisition, finding the suitable components, and cost, and lastly the simulation of designed hybrid system in Homer software.

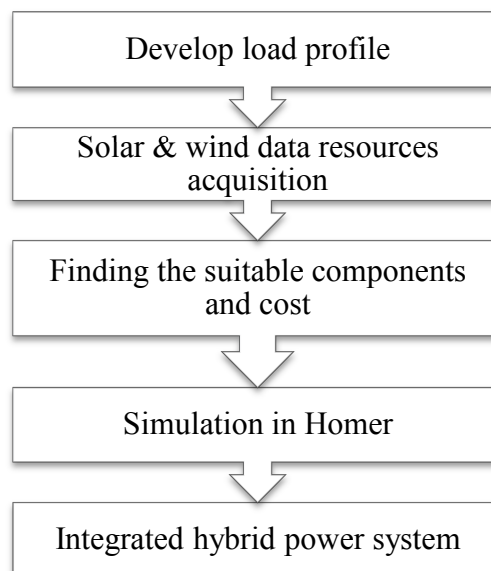

Figure 1: Steps in designing integrated hybrid power system

2.1. Load Profile Modelling

The load profile of the longhouse in Sabah is modelled with the consideration of the social activities of the local people. Since most of the rural communities of longhouses in Sabah are farmers and beads maker, therefore most of the activities will be weather depended. The load profile will be designed based on the weather conditions throughout the year, which is divided into three categories: hot days, rainy days and normal days. By assuming 20 families in a longhouse, the electrical appliances in a longhouse and the duration for each usage are estimated. Table 1 indicates the typical electrical appliances that could be found in a longhouse with its quantity and usage duration for a normal day. The longhouse has a maximum load demand of 16.4kW and average of 91.6kWh/day with a load factor of 0.232. Figure 2 shows the sample monthly load profile of a longhouse. At last, three types of daily load curves are developed based on the usage duration of Table 1 and are stated in Figure 3.

Table 1 Electrical appliances with its quantity (Qty) and usage duration per day for a normal day

	Electrical appliances	Power consumption (W)	Qty	Usage duration per day
1	Tube light (inside door)	36	40	1800-0000
2	Tube light (outside door)	36	20	1800-0600
3	Colour TV 19"	80	25	1800-2300
4	Refrigerator	100	5	0000-0000
5	Ceiling fan (inside door)	55	20	1800-0600
6	Ceiling fan (outside door)	55	10	1800-0000
7				1100-1800
8	Radio	50	10	1800-2000
9	Electric Iron	750	5	2000-2200
10	Cooker	1200	4	1100-1200
11				1700-1800
12	Washing machine	320	4	2000-2100

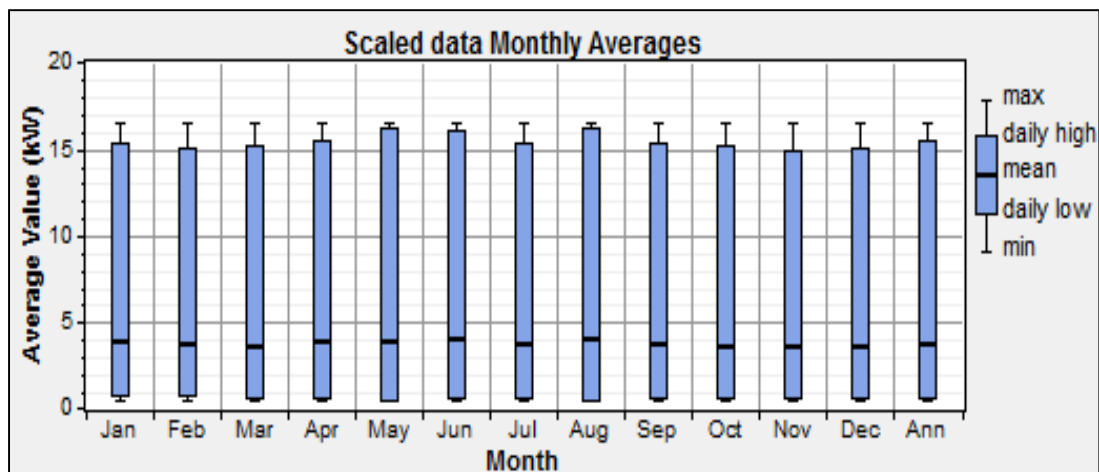
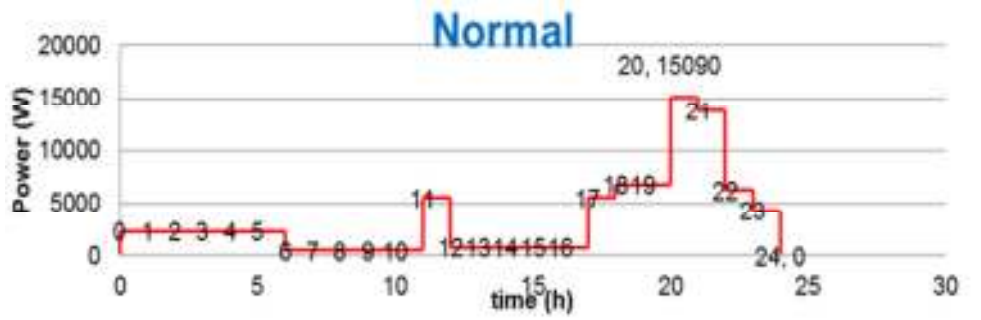
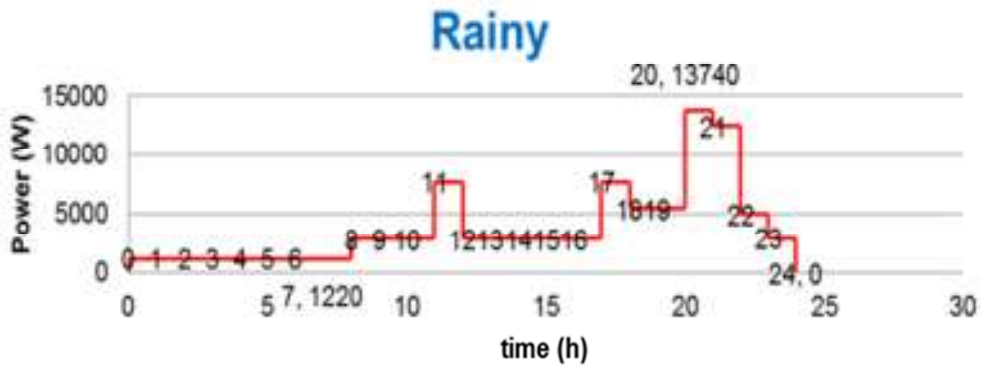

Figure 2: Monthly load profile



(a)



(b)

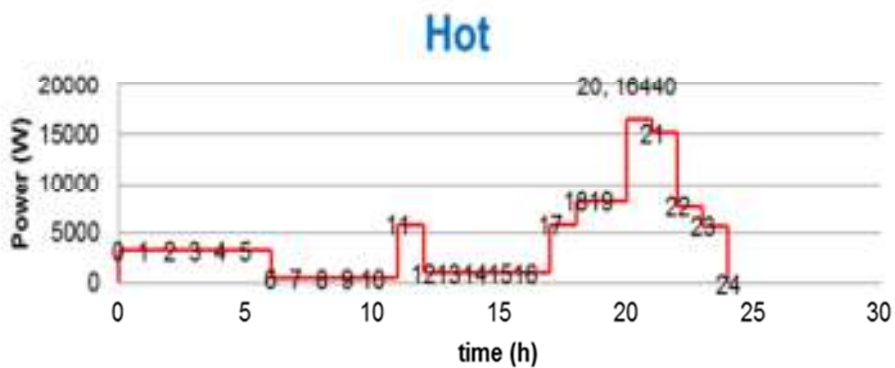

(c)

Figure 3: Daily load profile for (a) normal day, (b) rainy day and (c) hot day

The number of hot, rainy and normal days are obtained from the historic weather condition in Kudat for five years from year 2008 to 2012 [13]. It will be classified as hot days when the maximum temperature of the day reach 30°C and above; rainy days when moderate and heavy rain falls continuously for more than two hours within the period hour 0800 to 1700 while the rest is classified as normal days, which are summarised as in Table 2.

Table 2 Summary of hot days, rainy days and normal days from year 2008 to 2012 and the average

	Hot days	Rainy days	Normal days
2008	140	63	162
2009	149	50	166
2010	146	33	186
2011	134	52	179
2012	138	44	183
Average	141	48	176

The total consumption throughout a year is calculated, which equal to the summation of the product of power consumption for each day and the average number of day for hot, rainy and normal days. Hence, total consumption throughout the year is

$$84,585 \times 176 + 93,350 \times 48 + 99,660 \times 141 = 33,419.82 \text{ kWh/year}$$

2.2. Homer Physical Modelling

In this section, details on the modelling of power system physical operation in Homer are provided. The system compose of solar photovoltaic and wind generation as energy source and single electrical load. Extra components such as battery bank and ac-dc converter is used to make the system more applicable to cope with the intermittent of the renewable resources. In this project, the load is modelled as primary load which is the electrical demand that a power system must supply at once. Any deficiency in electrical supply will be reported as unmet load.

2.2.1. Solar Power System Model

Solar radiation data, also served as an indication of the amount of solar radiation to the earth surface in a typical year, is required to model a solar power system. These data vary remarkably by locations, which depends greatly on climate and latitude. The solar radiation data and clearness index, which is a measure of the atmosphere clearness, ranges from zero to one, is obtained via Homer online resources [14]. The data is based on solar radiation in latitude $6^{\circ}53'$ North and longitude $116^{\circ}50'$ East (Kudat) with time zone (GMT+08.00). Figure 4 shows the monthly averaged solar radiation data and clearness index of Malaysia where the average daily radiation equals to $5.012 \text{ kWh/m}^2/\text{day}$ and a clearness index of 0.505.

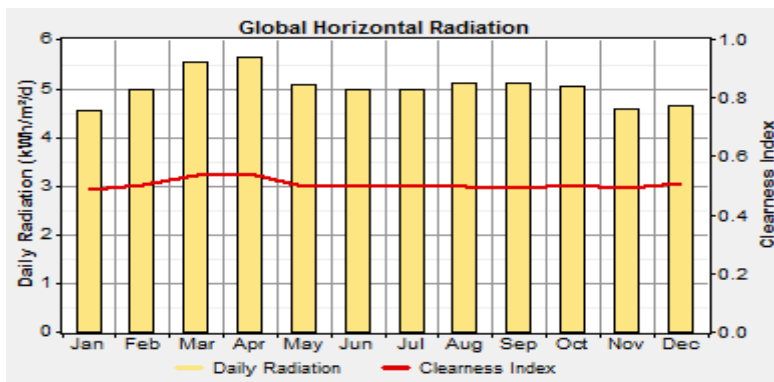

Figure 4: Monthly averaged solar radiation data and clearness index

The output power of photovoltaic (PV) array is given as equation below [13]:

$$P_{Output} = f_{PV} Y_{PV} \frac{I_R}{I_S} \quad (1)$$

Where f_{PV} is the PV derating factor; Y_{PV} is the PV array rated capacity in kW; I_R is the solar radiation radiated on the PV array surface in kW/m²; I_S is the standard radiation amount to rate PV array capacity in kW/m². The derating factor defines the deviation of PV array from the ideal performance caused by several effects, for example, wire losses, dust on PV panel, increased temperature and etc. The PV array rated capacity or peak capacity is the amount of power a PV array would generate under standard conditions: 25 °C panel temperature and 1 kW/m² radiation.

In the modelling of PV array, one important assumption is that the maximum power point tracker (MPPT) is present in the system. Hence, the output PV array will be consistent even the voltage of the system varies throughout the operation. PV panels sizing is calculated using PV calculator [15]. Finally, the selected PV panel is a polycrystalline type with rated power of 240Wp, nominal voltage of 30.6 Vm, nominal current of 7.84Im, efficiency of 14.7% and its derating factor equals to 77%, lifetime of 25 years with a tilt angle of 45°.

2.2.2. Wind Turbine Generator Model

Wind resource data is also based on the wind speed throughout a year in Kudat. Synthetic hourly wind speed data is generated ranges from January to December, with four advanced parameters: Weibull shape factor, autocorrelation factor, diurnal pattern strength and hour of peak wind speed [16]. Another important parameter is the anemometer height, height by which the wind speed data are measured or estimated. The difference of the turbine hub height and the anemometer height can lead to imprecise result, therefore, an extrapolation logarithmic law or power law is included for the wind speed adjustment at different height levels.

Four steps are involved in the process to determine the output power of the wind turbine for each hour.

- The average wind speed for a particular hour at the anemometer height is determined using wind resource data.
- The corresponding wind speed at the turbine's hub height is calculated using the extrapolation logarithm law.
- The wind turbine power curve is used to calculate the output power at different wind speed.
- The output power is multiplied by the air density ratio, the ratio of actual air density to the standard air density, which is assumed to be constant throughout the year.

The wind data is synthesized based on the Weibull parameter measured at height 80m with the scale parameter, $k=2.15$ and shape parameter, $c=7.51\text{m/s}$. The extrapolation of this value for the hub height at 12m is calculated and the new scale parameter, $k=1.76$ and shape parameter, $c=4.80\text{m/s}$ with an average wind speed of 4.269m/s where the autocorrelation factor is 0.76 and diurnal pattern strength is 0.218. Figure 5 shows the wind speed probability density function. The 12m hub height wind turbine has a lifetime of 15 years and its cut-in speed, 3.5m/s; rated speed, 12m/s and cut-out speed, 25m/s. Figure 6 displays the power curve of the rated 10kW FD 8.0 wind turbine.

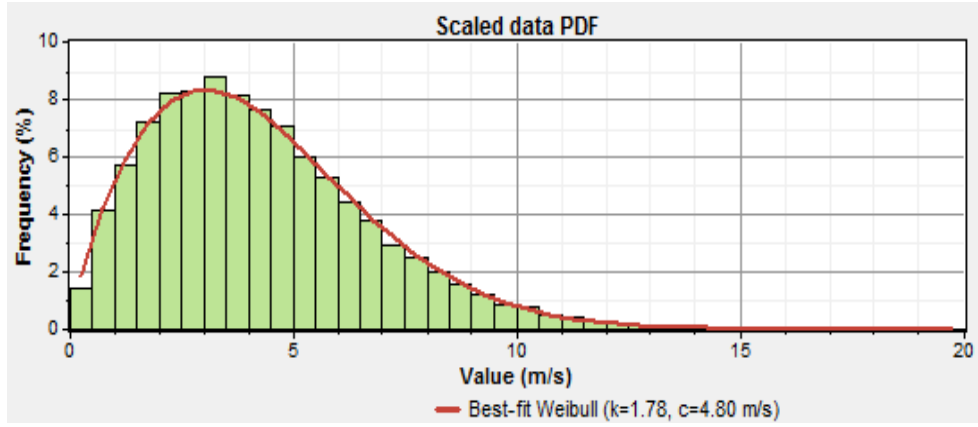

Figure 5: Wind speed probability density function

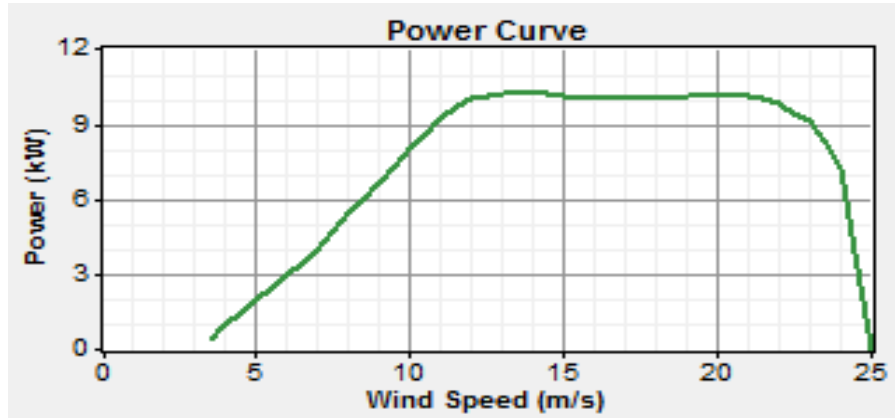

Figure 6: FD 8.0 power curve

2.2.3. Battery and Converter

Battery is a device capable of storing electricity when supply exceeds demand and discharging to produce electricity when needed. A few battery properties are essential to determine the capability of the battery, which includes the battery nominal voltage, round-trip efficiency and minimum state of charge. The round-trip efficiency is the factor to determine the efficiency of charging or discharging, while minimum state of charge represents the lower limit of battery level. The battery lifetime is independent of the cycle depth, and can be calculated as following equation [13]:

$$R_{bat} = \min \left(\frac{N_{bat} Q_{lifetime}}{Q_{thrupt}}, R_f \right) \quad (2)$$

where N_{bat} is the number of batteries; $Q_{lifetime}$ is the lifetime of a battery; Q_{thrupt} is the annual amount of energy cycles in the battery; R_f is the float life of the battery. There is an additional operation cost required which is the marginal cost of energy, defined as the sum of the battery wear cost and the battery energy cost. The battery wear cost is calculated using the following equation [14]:

$$C_{BW} = \frac{C_{rep}}{N_{bat} Q_{lifetime} \sqrt{\eta_{rt}}} \quad (3)$$

where C_{rep} is the replacement cost; N_{bat} is the number of batteries; $Q_{lifetime}$ is the lifetime of a battery; η_{rt} is the round-trip efficiency. Contrarily, the battery energy cost is calculated as the total charging cost of the battery over the years divided by the amount of energy put into the battery over the years.

The battery selected to be used in this project is a deep cycle lead-acid type which is suitable to be used for off-grid electrification. It has a nominal capacity of 1000Ah with 2V nominal voltage. Its round trip efficiency is 85%, minimum state of charge equal to 30%, maximum charge current of 202A and has weight of 62kg per battery. Twelve batteries are connected in series to get a 24V battery bank for this system. Pure sinusoidal inverter is selected for this hybrid system because pure sinusoidal waveform will not cause any damages to the electrical appliances. It has an efficiency of 90%, input voltage of 24V, output voltage of 230V, output frequency of 50Hz and a range of output power which is from 1kW to 200kW.

Alternatively, the only physical property requirement of the converter in Homer simulation is the capacity; while the economic properties of converter considered are the capital and replacement cost, operation and maintenance cost as well as its expected lifetime in years.

2.3. Homer Economic Modelling

In Homer, the economic modelling applies life-cycle cost analysis where costs such as the capital costs, replacement costs, maintenance costs and revenues from selling electricity to the grid and salvage value obtained at the end of the project lifetime, need to be included. The salvage value is calculated using the equation below [14]:

$$S = C_{rep} \frac{R_{re}}{R_{com}} \quad (4)$$

where C_{rep} is the component replacement cost; R_{re} is the component remaining lifetime; R_{com} is the component lifetime.

Net present cost (NPC) is used in calculating the life-cycle cost of the project, in which the future cash flows of total costs and revenues discounted back to the present using discounted rate. The total annualized cost is used to determine the NPC and the levelized cost of energy. It totals up all the costs used in the project minus the revenue obtained at the end of the project. The total NPC can be calculated using the below equation [13]:

$$C_{NPC} = \frac{C_{tot\ ann}}{f(i, R_{pro})} \quad (5)$$

where $C_{tot\ ann}$ is the total annualized cost; i is the annual interest rate, R_{pro} is the project lifetime; $f(i, R_{pro})$ is the capital recovery factor given the equation as follow [14]:

$$f(i, N) = \frac{i(i+1)^N}{(i+1)^N - 1} \quad (6)$$

where N is the number of years. In order to determine the levelized cost of energy, the following formula is used [14]:

$$LCOE = \frac{C_{tot\ ann}}{E_{load} + E_{grid}} \quad (7)$$

Where $C_{tot\ ann}$ is the total annualized cost; E_{load} is the total load demand per year; E_{grid} is the total energy sell to the grid per year. The minimum net present cost is chosen for different configurations of the system while the levelized cost of energy is used to compare the cost of different systems.

3. RESULTS AND DISCUSSIONS

After gathered all the required data and configuration, a complete off-grid hybrid system which consists of PV arrays, wind turbines and batteries is modelled. An inverter is included in this model as a device to convert electric power from DC to AC to supply the load. Figure 7 shows the configuration of off-grid hybrid PV/Wind/Storage system in Homer.

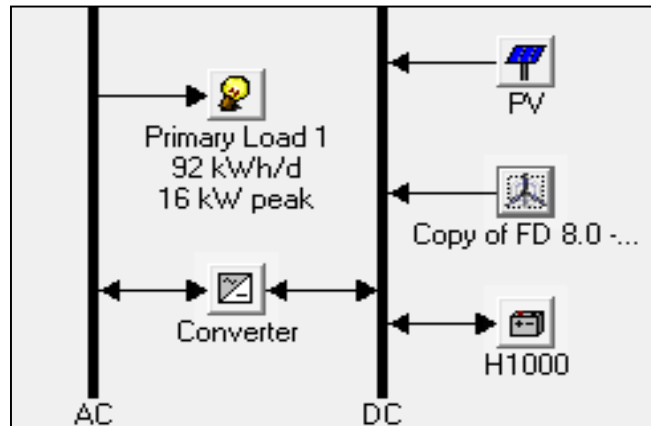

Figure 7: Configuration of off-grid hybrid PV/Wind/Storage system in Homer

A lifetime of 25 years is selected for this project and the optimization result of the project is obtained with Homer technical analysis simulation. After the simulation complete, the lowest life-cycle cost is determined in Table 3, which shows the optimal components quantity, size, capital, replacement and operation and maintenance cost of the hybrid system. Most of the components selected are in US dollar and they are converted back to Ringgit by multiplying the values with 4 which equals to the current currency exchange rate (as of November 2015).

Table 3 Components quantity and capital, replacement and operation and maintenance (O&M) cost the hybrid system

	Qty	Size	Capital (RM)	Replacement (RM)	O&M (RM)
PV array	6	0.24kW	1,128	1,128	0
Wind turbine	3	10kW	29,430	29,430	589
Inverter	8	2.5kW	2,000	2,000	0
Battery	144	1000Ah	1,200	1,200	12
Wind controller	12	24V	800	800	8
Solar controller	12	24V	1,440	1,440	14

Integrated hybrid system off-grid electrification is compared with diesel generators electrification power system, to verify the effectiveness and the feasibility of the proposed hybrid system. Two 10kW CSC Power diesel generators are implemented, where one generator will run the base load for 24 hours while another diesel generator is used to serve the peak load. A diesel generator has a capital and replacement cost of RM 26,000 whereas the O&M cost is zero. It has a lifetime of 20,000 operating hours and the diesel fuel price at current rate is RM1.90/liter. Table 4 displays the optimization result of net present value and levelised cost of energy (LCOE) for hybrid system and off-grid diesel electrification. From Table 4, the total net present value and the LCOE of

a hybrid system that consists of PV panels, wind turbines, batteries and converter is lower than the diesel electrification for a longhouse. This proves that the hybrid system is more economically feasible than the diesel electricity generation, with additional benefit such as environmental friendliness, as renewable hybrid system not contribute to any greenhouse gasses emission.

Table 4 The net present value and levelised cost of energy for hybrid system and diesel electrification

Diesel Generator (10kW)	PV (kW)	Wind Turbine (10kW)	Battery (2V, 1000Ah)	Converter (kW)	Total Net Present Value (RM)	LCOE (RM/kWh)
-	36	1	144	20	524,305	1.22
2	-	-	-	-	667,961	1.56

Figure 8 shows the production percentage of PV array and wind turbine and excess electricity at different hub heights (12m, 30m and 50m). The production percentage of the wind turbine, the excess electricity and the unmet electric load are investigated. The results shows that the production percentage increases with the increase in tower hub height. Mainly due to more energy is generated with the higher wind speed at higher height. It is also observed that the excess electricity is not much affected with the increase in hub height, while the unmet electric load shows a significant reduction, from 10.2 kWh/yr to 0.813 kWh/yr, when the hub tower locates at higher height. Hence, the wind turbine is recommended to be installed at hub height more than 30m. Although current state of technology development still does not support small wind turbine of more than 30m height but due to technology advancement, small wind turbine hub height of 30m may possibly available in future. Furthermore, when the proposed hybrid system is applied to a large load demand power system that consist of a few longhouses, installation of the medium wind turbine with the hub height of more than 30m or even 50m is possible.

Production	kWh/yr	%
PV array	45,836	75
Wind turbine	15,046	25
Total	60,883	100
Consumption	kWh/yr	%
AC primary load	33,423	100
Total	33,423	100
Quantity	kWh/yr	%
Excess electricity	19,865	32.6
Unmet electric load	10.2	0.0
Capacity shortage	25.9	0.1

(a) Hub height of 12m

Production	kWh/yr	%
PV array	36,669	61
Wind turbine	23,688	39
Total	60,357	100
Consumption	kWh/yr	%
AC primary load	33,423	100
Total	33,423	100
Quantity	kWh/yr	%
Excess electricity	19,766	32.7
Unmet electric load	7.61	0.0
Capacity shortage	33.2	0.1

(b) Hub height of 30m

Production	kWh/yr	%
PV array	30,557	52
Wind turbine	28,435	48
Total	58,993	100
Consumption	kWh/yr	%
AC primary load	33,423	100
Total	33,423	100
Quantity	kWh/yr	%
Excess electricity	18,612	31.6
Unmet electric load	0.813	0.0
Capacity shortage	8.08	0.0

(c) Hub height of 50m

Figure 8: The production percentage of PV array and wind turbine and excess electricity at different hub heights

4. CONCLUSION

An integrated hybrid power system that consists of PV arrays, wind turbines and batteries is successfully modelled for the longhouse in Kudat, Sabah. The system configuration satisfies both the technical and financial constraints where the total net present cost is RM524,305 and the levelised cost of energy (LCOE) is RM1.22/kWh for 25 years of project life. Compare with diesel electrification power system, the net present cost and LCOE of the hybrid system is lower which proves the economic feasibility of the hybrid power system to serve a longhouse in Sabah. The hybrid system also is environmental friendly as it did not produce any greenhouse gasses and therefore will help in combat with the environmental impact such as the global warming. The analysis indicates that the best hub height for the wind turbine is 50m, which proves with the reduction in excess electricity and unmet electric load. However, small wind turbine is not feasible to be installed more than 30m based on current state of technology development. In future, with the advancement in technology, higher hub height of small wind turbine may be available for installation, which is recommended to achieve better performance. Besides, excess electricity generated from the proposed hybrid power system can be sold back to the grid in future, after the extension of power system grid to the rural area along with the growth of the development in Malaysia.

REFERENCES

- [1] Forsberg, C. W. Sustainability by combining nuclear, fossil, and renewable energy sources. *Progress in Nuclear Energy*, 2009, 51(1): 192-200.
- [2] Shafiee, S. and Topal, E. When will fossil fuel reserves be diminished? *Energy Policy*. 2009, 37(1): 181-189.
- [3] Bagen and Billinton, R. Evaluation of Different Operating Strategies in Small Stand-Alone Power Systems. *IEEE Transactions on Energy Conversion*. 2005, 20(3): 654-660.
- [4] Panwar, N. L., Kaushik S. C. and Kothari, S. Role of renewable energy sources in environmental protection: A review. *Renewable and Sustainable Energy Reviews*. 2011, 15(3): 1513-1524.
- [5] Kota Belud & Rungus Longhouse Experience. 2015. November 2015. [Online]. Available: http://www.discoverytours.com.my/index.php?option=com_content&view=article&id=36&Itemid=39
- [6] Appell, G. Rungus Dusun. Encyclopedia of World Cultures Supplement. 2002. November 2015. [Online]. Available: <http://www.encyclopedia.com/doc/1G2-3458100084.html>
- [7] Borowy, B. S. and Salameh, Z. M. Methodology for optimally sizing the combination of a battery bank and PV array in a wind/PV hybrid system. *IEEE Transactions on Energy Conversion*. 1996, 11(2): 367-375.
- [8] Hongxing, Y., Wei, Z., Lin, L. and Zhaohong, F. Optimal sizing method for stand-alone hybrid solar-wind system with LPSP technology by using genetic algorithm. *Solar Energy*. 2008, 11(2): 367-375.
- [9] De, A. R. and Musgrove, L. The optimization of hybrid energy conversion systems using the dynamic programming model—Rapsody. *International Journal of Energy Research*. 1988, 12(3): 4474-57.
- [10] Yokoyama, R., Ito, K. and Yuasa, Y. Multiobjective Optimal Unit Sizing of Hybrid Power Generation Systems Utilizing Photovoltaic and Wind Energy. *Journal of Solar Energy Engineering*. 1994, 116(4): 167-173.
- [11] Kellogg, W. D., Nehrir, M. H., Venkataramanan, G. and Gerez, V. Generation unit sizing and cost analysis for stand-alone wind, photovoltaic, and hybrid wind/PV systems. *IEEE Transactions on Energy Conversion*. 1998, 13(1): 70-75.
- [12] Zhou, W., Lou, C., Li, Z., Lu, L. and Yang, H. Current status of research on optimum sizing of stand-alone hybrid solar-wind power generation systems. *Applied Energy*. 2010, 87(2): 380-389.
- [13] Forecast, Current condition, History and averages from Kudat Airport, Sabah, Malaysia (6.9200°N, 116.8300°E). 2015. November 2015. [Online]. Available: <http://weatherspark.com/#!graphs;ws=34020>
- [14] Waziruddin, S., Brogan, D. C. and Reynolds, P.F. Coercion through optimization: A classification of optimization techniques. *Proceedings of the Fall Simulation Interoperability Workshop*, 2004.
- [15] Lambert, T., Gilman, P. and Lilienthal, P. Micropower system modeling with Homer. *John Wiley & Sons. Inc*, 2006.
- [16] PV Calculator. 2015. November 2015. [Online]. Available: <http://pv-calculator.ch/pvcalculator/pvanlage>
- [17] The Swiss Wind Power Data Website: Power calculator. 2015. November 2015. [Online]. Available: <http://www.wind-data.ch/tools/powercalc.php?lng=en>

Acknowledgements

This work was supported by Malaysian Ministry of Higher Education Malaysia (MOHE) and Universiti Teknologi Malaysia (UTM) under the Fundamental Research Grant Scheme (FRGS), Vote No. 4F392.

The authors would like to thank Ms. Ng Siuk Sim, for assistance and support during the course of this project.