

Modeling and Simulation of Thermoelectric Generator (TEG) Performance Parameters Evaluation

Zamir Noor Abd Hamid, Norhaliza Abdul Wahab*, M. Sultan M Ali & M. Amri Yunos Control & Mechatronics Engineering Department
Faculty of Electrical Engineering Universiti Teknologi Malaysia Skudai, Johor
aliza@fke.utm.my

* corresponding author: aliza@fke.utm.my

Abstract

Nowadays, thermoelectric module is widely used for industrial application to produce electricity energy from wasted heat energy. This paper discusses thermoelectric generator (TEG) modeling and simulation to attain improvement. There are several methods to model the thermoelectric generator: finite element method (FEM) model, circuit equivalent model and mathematical/computer model. In order to perform FEM modeling analysis, any engineer should acquire high level of knowledge in material engineering. Circuit equivalent model is using electrical circuit analogy to describe heat transfer and electrical behavior in TEG. In this work, mathematical derivation from circuit equivalent model is used in computer model by using Simulink (Matlab). The result from computer model is an alternative model for electrical or electronics engineers to study and doing future improvements on TEG performance.

Keywords. Thermoelectric generator; thermoelectric cooler; thermoelectric module; Simulink

1 Introduction

Thermoelectricity idea and principle was firstly introduced by Thomas Johann Seebeck in 1821. A temperature different between two dissimilar metal will generate voltage. Peltier found that heating and cooling effect is produced from electrified two dissimilar junctions which are vice versa with Seebeck effect. In middle 1900's, the idea of semiconductor was applied in thermoelectricity for improvement needs by doping n-type and p-type structure [1]. Currently, Thermoelectric Module (TEM) is widely used in automotive and refrigerator systems [1]. TEM is a versatile device that can be used as Thermoelectric Cooler (TEC) or Thermoelectric Generator (TEG) which are applying Seebeck and Peltier effect respectively. Producing electricity by using TEG is the niche application for TEM because it is solid-state device which can provide compactness and noiseless. Maximum efficiency is not exceeding more than 12%, so it is not suitable practically for a power station [1]. As always, heat energy is being wasted by any industries but the application of TEG will use some heat energy to be converted as electrical energy. Mostly, low power integrated circuit like microcontrollers and sensors can be powered up by TEG [1].

There are several methods to simulate and model the TEG such as finite element method, circuit and Simulink or computer model. Finite element method was designed via finite element method. The device behavior is described by using boundary value for partial non-linear equation and it was verified by comparing with experimental result. This model is focusing on material properties and module design. It requires material engineering and physical properties knowledge. Usually, the suitable software for doing this kind of simulation is ANSYS which are in 3-D view of TEM geometry and condition for every mesh[2]. Circuit model is using electrical circuit analogy to describe the behavior of TEG by having two different circuits (thermal equivalent circuit and electrical circuit). Temperature represents electrical voltage, thermal resistance to electrical resistance and heat flux to electrical current [1]. This model implementation is suitable for power electronic application. SPICE-like simulator is being used to make it easy to understand by electrical or electronics engineering community. Simulink or computer block mod-

el for control objectives such as temperature control and Maximum power point tracking (MPPT)[3]. Plug in all formulas into formula block diagram in temperature domain.

2 Fundamental Principle of Thermoelectric Module

A TEM's circuit equivalent is always the same for TEG or TEC that can be used to simulate and model their characteristic. TEM also contains of p-type and n-type pellet in N-couples of series metal connection. There are for physical energy phenomenon taking part in TEM: thermal conduction, Joule heating, Peltier cooling/heating, Seebeck effect. Thompson effect was assumed zero because the value is small to be considered. Thermal conductivity is a type of Fourier processes that explain by thermal conductivity κ_{th} of any material and the heat transfer of thermal conduction is Equation (1):

$$Q_{th} = -\Delta T \kappa_{th} \quad (1)$$

Where:

$$\Delta T = T_H - T_c \quad (2)$$

T_H and T_c represent temperature at hot and cold sided respectively. Electrical energy across TEM produces power dissipation across internal resistance R. This phenomenon is called as Joule Heating, Q_J dissipated in TEM:

$$Q_J = I^2 R \quad (3)$$

2.1 Relation between Voltage and Heat Equations

Peltier phenomenon can be described as the two dissimilar conducting materials occurring at the junction in the presence of a flowing electrical current. The cold and hot junction $Q_{H/C} = S I T_{H/C}$, where S represents Seebeck coefficient. Finally, energy balance equation for every hot and cold side is determined by summing all heat energy transfer formula equations (4) and (5) below.

$$Q_H = S I T_H - 0.5 I^2 R - \Delta T \kappa_{th} \quad (4)$$

and

$$Q_C = S I T_c + 0.5 I^2 R - \Delta T \kappa_{th} \quad (5)$$

TEM output voltage is given as $V = V_s + IR$ with V_s represent Seebeck voltage. Application of line integration is used to formulate generated Seebeck voltage:

$$V_s = \int_{T_c}^{T_H} S dT = S \Delta T \quad (6)$$

Figure of merit (FOM) is a number to determine the suitability for the TEG application which combines with a large Seebeck coefficient and low R can be expressed

$$Z = \frac{S^2}{R \kappa_{th}} \quad (7)$$

2.2 Determination of TEG Performance Parameter

Mostly, parameters in datasheet from TEM manufacturers cover hot side temperature (T_H), cool side temperature (T_c), matched ratio load with internal resistance power (W_m) which mean ($R_L = R$) will produce matched voltage ($V_m = V_R$) [1]–[6]. Hence, the given parameters are useful to calculate electrical parameter for TEG circuit model by referring the datasheet.

$$(8) \quad R_L = R = \frac{V_m^2}{W_m}$$

and

$$(9) \quad S = \frac{2V_m}{\Delta T}$$

Equation (10) shows relationship between R_L and R and m is the ratio between them.

$$R_L = mR \quad (10)$$

Current flows and value depends on the temperature different.

$$I = \frac{S\Delta T}{(1+m)R} \quad (11)$$

At matched load, $m=1$;

$$I = \frac{S\Delta T}{2R} \quad (12)$$

The thermal efficiency of TEG value is a ratio between powers at load resistance to heat energy at hot side junction.

$$\eta_{th} = \frac{I^2 R_L}{Q_H} = \frac{m^2 \Delta T^2}{[(1+m)^2 + 2[(m+0.5)T_H + 0.5T_c]]} \quad (13)$$

At matched load

$$\eta_{th}^m = \frac{2\Delta T^2}{4 + 2[1.5T_H + 0.5T_c]} \quad (14)$$

Short circuit current at load resistance will doubled up the matched load current flow through internal resistance.

$$I_{SC} = 2I_m \quad (15)$$

So, the voltage output between generated current and I_{SC} representing short-circuit current which $V=0$:

$$V = -R(I - I_{SC}) \quad (16)$$

3 Results and Discussion

Figure 1 shows the main simulink block of the system to run the simulation for HZ-20(TEG) module from Hi-Z Technology which contain of 71active couples having 7.5cm(W)x7.5cm(L)x0.5cm(D) dimension. Hot side temperature is an input variable to monitor HZ-20 module output from current, efficiency and power scope the. From the observation, efficiency and power are measured from current domain perspective. All parameters obtained from datasheet are used in the system implementation: $W_m=22.0W$, $T_c=303K$, $V_m=2.38V$ and $\eta_{max}=4.5\%$ for matched load. Equations (8) and (9) are used to determine seebeck coefficient ($S=0.0238V/K$) and electrical resistance ($R=0.2674\Omega$).

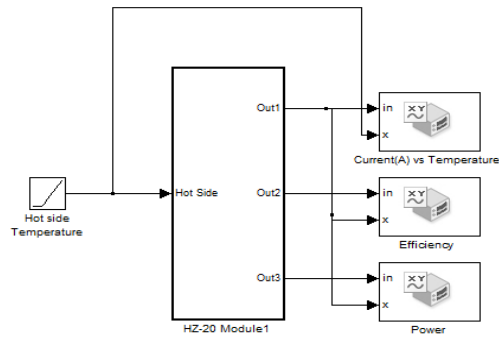

Fig. 1: Main Block System for HZ-20 module

Figure 2 shows the linear relationship between current and hot side temperature. From Figure 2, it shows that the current started flowing after 303K (refer equation 12). Increment of the current is too slow compared to the increment of temperature due to its dependency on the material that is selected by manufacturer.

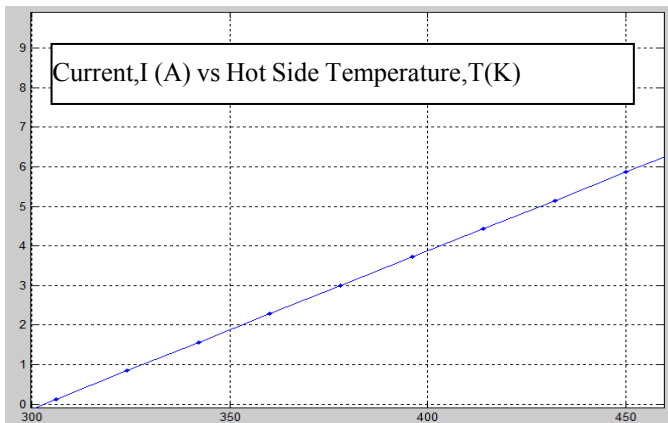

Fig. 2 : Simulation result for Current(A) - Hot Side temperature(K)

Figure 3 shows the simulation result for efficiency and it is represented in current function. HZ-20 module is having optimum efficiency at 4.8%, and current (I) approaches about 8.0A with 200K temperature different. This type of TEG is suitable for medium scale applications.

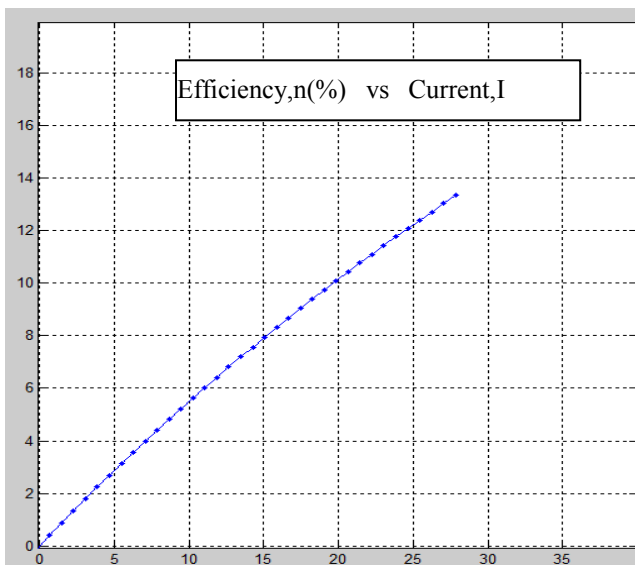

Fig. 3: Simulation Result for Efficiency (%) – Current (A)

Figure 4 shows power curve from simulation result for HZ-20 module which is similar to manufacturer datasheet (Figure 5). The maximum power dissipated across load resistance (R_L) is around 22W and current approaches about 9.80A. From Figure 5 also shows that for the efficiency of 4.8%; $I=8.0A$, it shows that maximum power does not contribute to the maximum efficiency as presented in Figure 3.

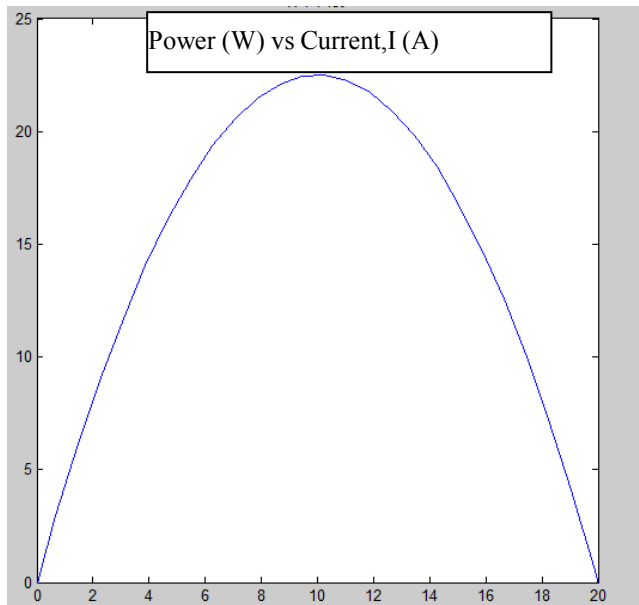

Fig. 4: Simulation Result for Electrical Power (W) – Current (A)

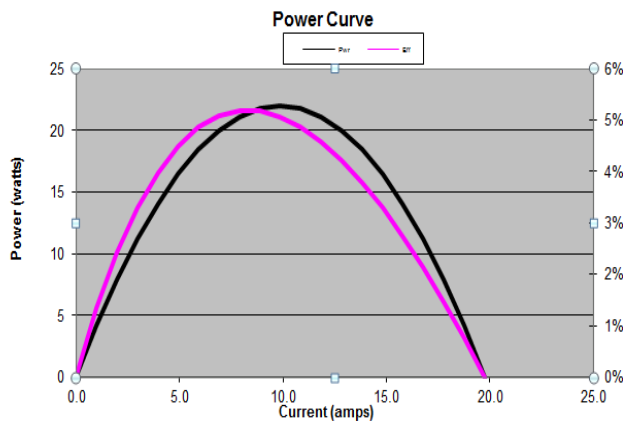

Fig. 5: Manufacturer characteristic datasheet for Power (W)-Current (A) and Efficiency (%)-Current (A)

4 Conclusion

Based on comparison of performance result from simulation and manufacturer datasheet, Simulink/computer block modeling can be used to replace experimental method by manufacturer in order to obtain the required parameters. This type of modeling is suitable for electrical or electronic engineers, which have limited knowledge in material engineering to study the performance of various types of TEG. Simulink block libraries also support electronics circuit simulation. Therefore, improvement for TEG can be done for various loading effect.

ACKNOWLEDGMENT

The authors would like to thank the Research University Grant Vote 02G15 Universiti Teknologi Malaysia for its financial support.

References

- [1] P. Dziurdzia, "Modeling and Simulation of Thermoelectric Energy Harvesting Processes," 2010.
- [2] T. Seetawan, U. Seetawan, a. Ratchasin, S. Srichai, K. Singsoog, W. Namhongsa, C. Ruttanapun, and S. Siridejachai, "Analysis of Thermoelectric Generator by Finite Element Method," *Procedia Eng.*, vol. 32, pp. 1006–1011, Jan. 2012.
- [3] H.-L. Tsai and J.-M. Lin, "Model Building and Simulation of Thermoelectric Module Using Matlab/Simulink," *J. Electron. Mater.*, vol. 39, no. 9, pp. 2105–2111, Nov. 2009.
- [4] S. Lineykin and S. Ben-Yaakov, "Modeling and Analysis of Thermoelectric Modules," *IEEE Trans. Ind. Appl.*, vol. 43, no. 2, pp. 505–512, 2007.
- [5] G. Snyder, "Small Thermoelectric Generators," *The Electromechanical Society Interface*, no. 2, pp. 54–56, Fall 2008.
- [6] A. Montecucco and A. R. Knox, "Accurate simulation of thermoelectric power generating systems," *Appl. Energy*, vol. 118, pp. 166–172, Apr. 2014.