

A Ferredoxin Disulfide Reductase Delivers Electrons to the *Methanosarcina barkeri* Class III Ribonucleotide Reductase

Yifeng Wei,^{*,†} Bin Li,[§] Divya Prakash,^{||} James G. Ferry,^{||} Sean J. Elliott,[§] and JoAnne Stubbe^{*,†,‡}

[†]Department of Chemistry and [‡]Department of Biology, Massachusetts Institute of Technology, 77 Massachusetts Avenue, Cambridge, Massachusetts 02139, United States

[§]Department of Chemistry, Boston University, 590 Commonwealth Avenue, Boston, Massachusetts 02215, United States

^{||}Department of Biochemistry and Molecular Biology, Pennsylvania State University, University Park, Pennsylvania 16802, United States

S Supporting Information

ABSTRACT: Two subtypes of class III anaerobic ribonucleotide reductases (RNRs) studied so far couple the reduction of ribonucleotides to the oxidation of formate, or the oxidation of NADPH via thioredoxin and thioredoxin reductase. Certain methanogenic archaea contain a phylogenetically distinct third subtype of class III RNR, with distinct active-site residues. Here we report the cloning and recombinant expression of the *Methanosarcina barkeri* class III RNR and show that the electrons required for ribonucleotide reduction can be delivered by a [4Fe-4S] protein ferredoxin disulfide reductase, and a conserved thioredoxin-like protein NrdH present in the RNR operon. The diversity of class III RNRs reflects the diversity of electron carriers used in anaerobic metabolism.

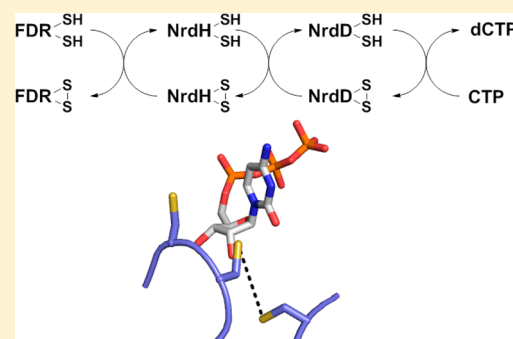

In many anaerobic bacteria and archaea, the reduction of ribonucleotides to deoxyribonucleotides is conducted by an O_2 -sensitive class III ribonucleotide reductase (RNR).¹ The class III RNRs that have been most extensively characterized, from bacteriophage T4 and its host *Escherichia coli*, use formate as the hydrogen donor for nucleotide reduction, oxidizing it to CO_2 .² We recently reported a second subtype of class III RNR from the bacterium *Neisseria bacilliformis*, which uses the thioredoxin (TrxA)/thioredoxin reductase (TrxB)/NADPH system for nucleotide reduction.³ Here we describe a third subtype of class III RNR from the methanogenic archaeon *Methanosarcina barkeri*, which uses a reduction system consisting of a [4Fe-4S] protein ferredoxin disulfide reductase (FDR1) and a conserved thioredoxin-like protein present in the RNR operon (NrdH), in conjunction with the ferredoxin-dependent anaerobic metabolism of this organism.

RNRs are essential enzymes present in nearly all cellular organisms and many viruses.^{4,5} All RNRs characterized to date consist of a structurally homologous α protein that initiates radical-dependent nucleotide reduction via a transient thiyl radical on a conserved Cys residue on the top face of the ribose in the active site.^{6,7} Apart from the class III RNR, there are two additional classes of RNR that differ in the cofactor used to generate this thiyl radical.⁸ Class I RNRs use cofactors that require reduced metals (Fe, Mn, and Fe/Mn) and O_2 for their biogenesis and are present only in aerobic organisms. Class II RNRs (NrdJ) use adenosylcobalamin (AdoCbl) in an O_2 -independent reaction and are present in both aerobes and anaerobes. Class III RNRs use an O_2 -sensitive glycol radical (G^\bullet) situated in the α protein (NrdD),⁹ which is generated by a

separate activating enzyme (NrdG) via radical S-adenosylmethionine (SAM)-[4Fe-4S]⁺ chemistry.¹⁰ The class III RNRs are only found in facultative and obligate anaerobes.

The mechanism of nucleotide reduction has been most extensively studied in the class I and II RNRs, where deoxynucleotide formation proceeds with the concomitant generation of a disulfide between a pair of conserved Cys residues on the bottom face of the ribose in the active site (Figure 1A).¹¹ Subsequent turnovers require the reduction of this disulfide by a redoxin protein (thioredoxin, glutaredoxin, or NrdH).^{12–14} The radical-dependent reduction mechanism requires acid/base catalysis by a conserved Glu residue in the active site (Figure 1A).⁷

In contrast, the *E. coli* and bacteriophage T4 class III RNR (subtype NrdD1) use formate as a reductant and have a single Cys on the bottom face (Figure 1B).^{2,15} Reaction of NrdD1 with nucleotide results in the formation of a thiosulfuranyl radical involving a three-electron bond between this Cys and a conserved Met residue (Figure 1B).¹⁶ This radical is thought to be the oxidant of formate and was shown to be chemically competent for formation of the deoxynucleotide product.

A recent bioinformatics study led us to identify a second class III RNR subtype (NrdD2) with distinct active-site residues, suggesting a different mechanism for nucleotide reduction.³ In NrdD2, the active-site Met is not conserved, and the presence

Received: October 6, 2015

Revised: November 4, 2015

Published: November 4, 2015

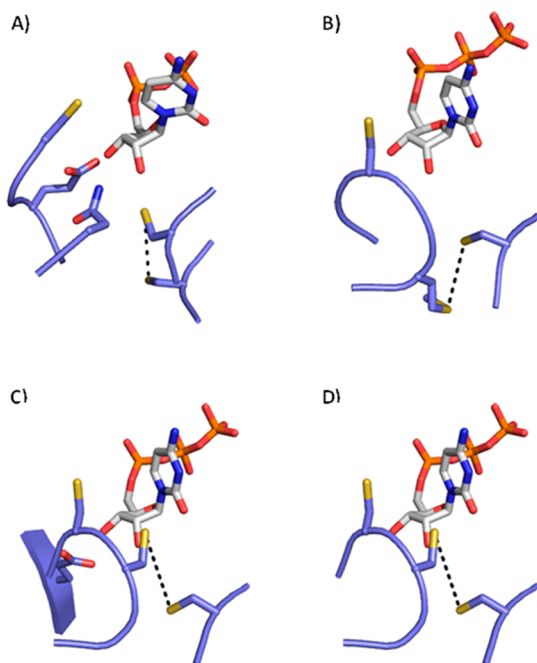

Figure 1. Active-site models for RNRs, showing conserved residues thought to participate in catalysis. (A) *T. maritima* NrdJ (from the crystal structure of PDB entry 1XJN).¹⁸ (B) Bacteriophage T4 NrdD1 (based on the crystal structure of PDB entry 1HK8).¹⁵ (C) *T. maritima* NrdD2 (based on the crystal structure of PDB entry 4U3E; the substrate and thiol radical loop, absent in the crystal structure, are modeled as described in ref 3). (D) *M. barkeri* NrdD3 (based on panel C, showing the lack of a conserved Glu residue). Dashed lines connect S atoms involved in the formation of disulfide (A, C, and D) or thiosulfuranyl radical (B).

of a pair of bottom face Cys residues and a Glu residue in the active site suggested redoxin-dependent chemistry similar to that of the class I and II RNRs (Figure 1C). In the crystal structures of *Thermotoga maritima* NrdD2, obtained independently by us and by Aurelius et al.,¹⁷ the active-site “thiol radical loop” is displaced from its expected position compared to those of other RNRs, and both we and Aurelius et al. have suggested that these structures may represent an inactive state of the enzyme. Nevertheless, a model constructed on the basis of the crystal structure suggested that the bottom face Cys and Glu residues were in a suitable position to conduct RNR chemistry.³ Biochemical evidence was provided in studies of recombinant *N. bacilliformis* NrdD2, which established that nucleotide reduction could be conducted using the *E. coli* TrxA/TrxB/NADPH system as the electron source.

The NrdD subtype present in an organism was observed to correlate with its anaerobic metabolism.³ The redoxin-dependent NrdD2 is the most widely distributed subtype, present in diverse nonfermenting bacteria and nonmethanogenic archaea, in conjunction with the nearly universal occurrence of redoxins. Among bacteria, the formate-dependent NrdD1 is present in fermenting bacteria where pyruvate-formate lyase catalyzes the conversion of pyruvate to formate and acetyl-CoA.¹⁹ Among methanogenic archaea, NrdD1 is present in class I methanogens (Methanopyrales, Methanococcales, and Methanobacteriales)²⁰ and in Rice cluster I. These organisms conduct methanogenesis by reduction of CO₂ with H₂ and can generate formate reversibly using the F₄₂₀-dependent formate dehydro-

genase. Formate is also used in these organisms for purine biosynthesis²¹ and as a substrate for methanogenesis.²²

Class II methanogens (Methanomicrobiales and Methanosarcinales)²⁰ contain a third subtype of class III RNR (NrdD3). Unlike the class I methanogens, many of these organisms lack formate dehydrogenase and use formyl-THF for purine biosynthesis. The source of electrons for nucleotide reduction by NrdD3 is unknown. Although NrdD3 is phylogenetically more closely related to methanogen NrdD1s, its active site more closely resembles that of NrdD2, lacking the catalytic Met, but containing a pair of bottom face Cys residues (Figure 1D).³ Also, all NrdD3 operons contain a thioredoxin-like protein, NrdH, suggesting redoxin-dependent chemistry. However, unlike other redoxin-dependent RNRs, homology models suggest that NrdD3 lacks an active-site residue that could perform acid/base catalysis (Figure 1D),³ suggesting differences in the mechanism of nucleotide reduction.

Although NrdD2 is the most widely distributed class III RNR, it is uncommon in methanogens. We speculate that this may be related to the unique electron carriers used in methanogenesis, which include ferredoxin (Fdx) and coenzyme F₄₂₀,²³ instead of reduced pyridine nucleotides, the source of electrons for TrxB.

In addition to the NADPH-dependent TrxB, many methanogens contain the Fdx-dependent ferredoxin disulfide reductase (FDR),²⁴ a [4Fe-4S] protein related to plant ferredoxin:thioredoxin reductase (FTR),²⁵ which could provide a route for nucleotide reduction using electrons from Fdx, via NrdH and NrdD3 (Figure 2). A FDR from *Methanosarcina*

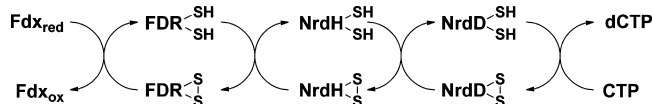

Figure 2. Model for Fdx-dependent nucleotide reduction by *M. barkeri* NrdD. Fdx provides the electron source for reduction of FDR, which reduces the redoxin NrdH, which in turn regenerates the active-site Cys pair required for nucleotide reduction by NrdD. In our assays, Ti(III) citrate was used as a surrogate for reduced Fdx.

acetivorans (which we call FDR2) was recently structurally and biochemically characterized and found to mediate the reduction of disulfides using electrons from *M. acetivorans* Fdx.²⁴ In addition to the [4Fe-4S] domain, FDR2 contains a C-terminal rubredoxin domain thought to be involved in the transport of electrons to the catalytic site. The gene sequence for FDR2 in *M. acetivorans* occurs adjacent to that of methanoredoxin (MRX), a glutaredoxin-like protein with protein disulfide reductase activity.²⁶ Apart from FDR2, *Methanosarcina* species contain one other FTR-like protein (FDR1), lacking the C-terminal rubredoxin domain.

To investigate the source of electrons for nucleotide reduction by NrdD3, we cloned and reconstituted the class III RNR system from the model methanogen *M. barkeri*, demonstrating that *M. barkeri* NrdD3 can catalyze nucleotide reduction using a recombinant NrdH/FDR1 system (Figure 2). The distribution of this subtype of class III RNR is discussed in relation to the different methanogenic pathways that exist in these organisms.

■ MATERIALS AND METHODS

Materials and General Methods. All chemical reagents were purchased from Sigma-Aldrich, unless otherwise indicated.

and transferred into 200 mL of LB. For expression of MbNrdD, which contains a putative Zn binding site, 50 μM ZnSO_4 was added to the medium.³⁴ The cultures were grown at 37 °C while being shaken at 200 rpm. At an OD_{600} of ~ 0.8 , the temperature was decreased to 25 °C (or 30 °C for FDR1) and IPTG (Promega) was added to a final concentration of 0.1 mM. After 12 h (or 4 h for FDR1), cells were harvested by centrifugation (4000g for 10 min at 4 °C). The typical yield was ~ 5 g of cell paste/L.

Standard Procedure Used for Purification of MbNrdG, MbFDR1, MbTrxB, and LINrdJ. After being harvested, the cells (~ 1 g) were suspended in 5 mL of lysis buffer [50 mM Tris-HCl (pH 8), 1 mM phenylmethanesulfonyl fluoride (PMSF), 0.2 mg/mL lysozyme, 0.03% Triton X, and 1 μL of Benzoylarginine hydrochloride (Novagen)]. For MbTrxB, additional 50 μM flavin adenine dinucleotide (FAD) was added. The cell suspension was frozen at -80 °C and then thawed and incubated at room temperature for 40 min to allow lysis. Fifteen milliliters of buffer A [20 mM Tris (pH 7.5) and 5 mM β -mercaptoethanol (BME)] containing 1.3% streptomycin sulfate was added. The mixture was shaken for an additional 10 min, and the precipitated DNA was removed by centrifugation (20000g for 10 min at 4 °C). Solid $(\text{NH}_4)_2\text{SO}_4$ was then added to 60% saturation. The solution was shaken for an additional 10 min, and the precipitated protein was isolated by centrifugation (20000g for 10 min at 4 °C).

The pellet was dissolved in 20 mL of buffer B [20 mM Tris (pH 7.5), 5 mM BME, and 0.2 M KCl] and incubated with 2 mL of TALON resin (Clontech) while being shaken for 30 min. The column was then packed (0.8 cm \times 4 cm) and washed with 10 column volumes (CV) of buffer B. Protein was eluted with 5 CV of buffer B containing 150 mM imidazole. The eluted protein was precipitated with solid $(\text{NH}_4)_2\text{SO}_4$ to 60% saturation and isolated by centrifugation (20000g for 10 min at 4 °C). The pellet was dissolved in 0.5 mL of buffer B and desalted using a Sephadex G-25 column (1.5 cm \times 8.5 cm, 15 mL), pre-equilibrated with buffer C [20 mM Tris (pH 7.5), 50 mM KCl, 5% glycerol, and 1 mM dithiothreitol (DTT)]. The eluted protein was concentrated to ~ 400 μL by ultrafiltration (Amicon YM-30), frozen in aliquots in liquid N_2 , and stored at -80 °C [for yields, extinction coefficients, and sodium dodecyl sulfate–polyacrylamide gel electrophoresis (SDS–PAGE) gels, see Figure S1].

Purification of MbNrdH, MbMRX, and MbTrxA. The lower-molecular weight thioredoxin-like proteins were purified by modification of the standard procedure described above. After being harvested, the cells (~ 1 g) were suspended in 5 mL of 20 mM Tris (pH 7.5), followed by lysis by three freeze–thaw cycles. The subsequent steps were identical to those described above, except that BME and DTT were omitted from all buffers, and protein precipitation was conducted using $(\text{NH}_4)_2\text{SO}_4$ to 70% saturation (for yields, extinction coefficients, and SDS–PAGE gels, see Figure S1).

Purification of MbNrdD. MbNrdD required high concentrations of salt and/or glycerol for stability and was purified by modification of the standard procedure described above. After lysis, streptomycin sulfate precipitation, ammonium sulfate precipitation, and binding to the TALON resin, the column was washed with 5 CV of buffer B, then 10 CV of buffer B containing 2 M NaCl to remove bound DNA, and then 5 CV of buffer B. Protein was eluted with 5 CV of buffer D [20 mM Tris (pH 7.5), 300 mM KCl, and 20% glycerol] containing 150 mM imidazole and 5 mM BME. The eluted protein was precipitated

with solid $(\text{NH}_4)_2\text{SO}_4$ to 60% saturation and isolated by centrifugation (20000g for 10 min at 4 °C). The pellet was dissolved in 0.5 mL of buffer D and desalted using a Sephadex G-25 column (1.5 cm \times 8.5 cm, 15 mL), pre-equilibrated with buffer D containing 1 mM DTT. The eluted protein was concentrated to ~ 300 μM by ultrafiltration (Amicon YM-30), frozen in aliquots in liquid N_2 , and stored at -80 °C (for yields, extinction coefficients, and SDS–PAGE gels, see Figure S1).

Reconstitution of [4Fe-4S] Clusters of MbNrdG and MbFDR1. The procedure was conducted in a glovebox. Solutions of Na_2S and $\text{Fe}(\text{NH}_4)_2(\text{SO}_4)_2$ in water (100 mM) were freshly prepared in the glovebox. Solutions of the respective proteins (~ 200 μM) were made anaerobic on a Schlenk line and brought into the glovebox. A solution of DTT (1 M) was added to a final concentration of 10 mM, followed by ordered addition of the solution of Na_2S (5 equiv) and $\text{Fe}(\text{NH}_4)_2(\text{SO}_4)_2$ (5 equiv). The mixture was incubated for 12 h at 4 °C. Ethylenediaminetetraacetic acid (EDTA, 5 equiv) was then added, and the solution was desalted by repeated dilution with 20 mM Tris (pH 7.5) and concentration by ultrafiltration (Amicon YM-30). The final material contained 3.3 atoms of Fe per NrdG peptide and 3.6 atoms of Fe per FDR1 peptide, determined by the ferrozine assay.³⁵

Generation of the MbNrdD G \cdot . In a 1.5 mL polypropylene Eppendorf tube, a 50 μL mixture of MbNrdD (40 μM), MbNrdG (40 μM), SAM (1 mM), bicine potassium salt (pH 7.5, 10 mM), 3,6-diaminoacridine hydrochloride (10 μM), Tris (pH 7.5, 20 mM), KCl (300 mM), and glycerol (20%) was placed 1 m from a fluorescent lamp in the glovebox at 30 °C for 1 h. This mixture was used directly for assays without further purification. For inspection by X-band electron paramagnetic resonance (EPR) spectroscopy, the reaction was conducted on a 200 μL scale in an EPR tube sealed with a rubber stopper and quenched in liquid N_2 immediately after the mixture had been removed from the glovebox. The amount of G \cdot in the solution was determined by comparing the EPR signal intensity to that of a CuSO_4 standard.³⁶ A typical yield of 0.1 G \cdot per NrdD polypeptide was reproducibly obtained.

X-Band EPR Spectroscopy. Continuous wave X-band EPR spectra were recorded at 77 K in the MIT Department of Chemistry Instrumentation Facility on a Bruker ESP-300 X-band spectrometer equipped with a quartz finger Dewar filled with liquid N_2 . Experimental conditions were as follows: microwave frequency, 9.45 GHz; modulation amplitude, 0.15 mT; modulation frequency, 100 kHz; time constant, 5.12 ms; scan time, 41.9 s; microwave power, 20 μW .

Activity Assay for dCTP Formation by MbNrdD Using DTT as the Electron Source. The assay mixture contained, in 50 μL , MbNrdD (10 μM , ~ 1 μM G \cdot), MbNrdH (10 μM), ATP (0.5 mM), 5- ^3H CTP (0.5 mM, 3730 cpm/nmol), and DTT (2 mM) in assay buffer [50 mM Tris (pH 7.5), 200 mM KCl, and 10 mM MgSO_4] and was incubated at 30 °C. Aliquots (10 μL) were removed at 30 s intervals and reactions quenched with 2% perchloric acid (10 μL). Subsequent to neutralization and removal of the phosphates using calf intestine alkaline phosphatase (Roche), dCTP formation was analyzed by the method of Steeper and Steuart.³⁷ One unit of activity is equivalent to 1 nmol of dCTP/min. The specific activity of MbNrdD is 55 units/mg of NrdD protein (~ 0.83 s $^{-1}$ per G \cdot).

Protein Film Voltammetry (PFV) of MbNrdH. All potential measurements were performed in a glovebox (MBraun) with a PGSTAT 12 potentiostat (EcoChemie). A three-electrode configuration, including a standard calomel

reference electrode, a platinum counter electrode, and a pyrolytic graphite edge (PGE) working electrode, was used in conjunction with an electrochemical cell. The cell was water jacketed and connected to a circulator for temperature control. In this study, the temperature was maintained at 25 °C for all experiments. In each experiment, the PGE working electrode was sanded, polished with 1.0 μm alumina slurry, and sonicated for >10 min before use. Protein films were generated by painting the graphite surface of the working electrode with droplets of a concentrated protein solution (4.6 mM, usually 2–5 μL). The working electrode was subsequently placed in the protein-free buffer solution of the electrochemical cell and subjected to the cycling of applied potentials. All buffers were prepared anaerobically, with sodium acetate (5 mM), MES (5 mM), MOPS (5 mM), TAPS (5 mM), CHES (5 mM), CAPS (5 mM), and sodium chloride (150 mM), and adjusted to a pH range of 4.5–9.5. The raw voltammograms were analyzed with SOAS.³⁸

Activity Assay for dCTP Formation by MbNrdD Using Ti(III) Citrate as the Electron Source. Reproducible activity was obtained by initiating the reaction in the following manner. To a 32.5 μL mixture containing ATP, 5- ^3H CTP, Ti(III) citrate, and assay buffer was added 5 μL of MbFDR1, followed immediately by a 12.5 μL mixture containing MbNrdD and MbNrdH. The final assay mixture contained, in 50 μL , MbNrdD (10 μM , $\sim 1 \mu\text{M G}^\bullet$), MbNrdH (10 μM), MbFDR1 (10 μM), ATP (0.5 mM), 5- ^3H CTP (0.5 mM, 3730 cpm/nmol), and Ti(III) citrate (1 mM) in assay buffer and was incubated at 30 °C. Aliquots (10 μL) were removed at 30 s intervals and reactions quenched with 2% perchloric acid (10 μL). Workup is as described above. The specific activity of MbNrdD under these conditions was 41 units/mg of NrdD protein ($\sim 0.61 \text{ s}^{-1}$ per G^\bullet).

Stoichiometry of Ti(III) Consumption and dCTP Production. The assay mixture was divided into 10 μL aliquots containing MbNrdD (10 μM , $\sim 1 \mu\text{M G}^\bullet$), MbNrdH (2 μM), MbFDR1 (2 μM), dATP (0.1 mM), 5- ^3H CTP (0.5 mM, 3730 cpm/nmol), and varying amounts of Ti(III) citrate (0–0.6 mM) in assay buffer. The reaction was initiated as described above and the mixture incubated at 30 °C for 2 h to allow for complete consumption of Ti(III). Workup to quantify dCTP formed is as described above.

Activity Assay for Reduction of DTNB by MbTrxB. The assay mixture contained, in 300 μL , MbTrxB (10 nM; we used an extinction coefficient ϵ_{456} of 11300 $\text{M}^{-1} \text{cm}^{-1}$ previously measured for *E. coli* TrxB³⁹), NADPH (0.3 mM), 5,5'-dithiobis(2-nitrobenzoic acid) (DTNB, 1 mM), Tris (pH 7.5, 50 mM), and EDTA (0.1 mM), sealed in an anaerobic cuvette, incubated at 30 °C, and monitored by the change in A_{412} (assuming $\epsilon_{412} = 14150 \text{ M}^{-1} \text{cm}^{-1}$). The specific activity was 3.4 $\mu\text{M min}^{-1} \text{mg}^{-1}$, calculated as previously described.^{40,41}

Activity Assay for dCTP Formation by LlnrdJ Using the *M. barkeri* Thioredoxin System. The procedure was adapted from existing protocols⁴² and was conducted in the glovebox to avoid the reported reaction of the archaeal TrxB with O_2 .⁴⁰ The assay mixture contained, in 50 μL , LlnrdJ (1 μM), AdoCbl (10 μM), TrxA (100 μM), TrxB (1 μM), dATP (0.12 mM), 5- ^3H CTP (1 mM, 3730 cpm/nmol), NADPH (2 mM), HEPES (50 mM, pH 7.5), EDTA (4 mM), and MgSO_4 (1 mM) and was incubated at 30 °C. Aliquots (10 μL) were removed at 30 s intervals and reactions quenched with 2% perchloric acid (10 μL). Workup is as described above. The

specific activity of LlnrdJ is 420 or 200 units/mg using the *E. coli* or *M. barkeri* thioredoxin system, respectively.

RESULTS

Generation of the MbNrdD G^\bullet . For our studies of NrdD3, we chose the model methanogen *M. barkeri*.⁴³ Initial attempts to purify MbNrdD were confounded by the instability of the protein, which aggregated over time and bound tightly to various chromatographic resins and to DNA. We later found that this instability and nonspecific binding could be overcome by addition of 200–300 mM KCl and/or 20% glycerol to the buffers used for chromatography, storage, and assays. To generate active MbNrdD for biochemical studies, we incubated MbNrdD with MbNrdG and SAM in the presence of the diaminoacridine/bicine photoreduction system,³ resulting in the generation of a radical with a characteristic doublet EPR signal (Figure 3), consistent with its assignment as G^\bullet .

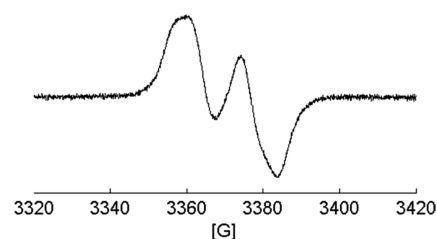

Figure 3. EPR spectrum of the MbNrdD G^\bullet (40 μM NrdD peptide).

MbNrdD stored in buffer containing 20 mM Tris (pH 7.5), 300 mM KCl, and 20% glycerol was stable at 4 °C in the glovebox for several weeks, during which a yield of $\sim 0.1 \text{ G}^\bullet$ per NrdD peptide was reproducibly obtained.

Reduction Potential of MbNrdH. All NrdD3 sequences that we have examined, from methanogens that have been sequenced to date, occur adjacent to a thioredoxin-like protein NrdH, making it a likely candidate for the electron donor for NrdD3. To investigate this possibility, we conducted PFV of MbNrdH to determine its reduction potential (Figure 4A).

The potential of MbNrdH at pH 7.0 and 25 °C was determined to be -250 mV (vs SHE), with a variation of 1–2 mV in each experiment. The half-height widths of the peaks (δ) are 59.5 and 60.9 mV for the reductive and oxidative peaks, respectively. The values are between the theoretical half-height widths for one-electron (89 mV) and two-electron (44.5 mV) redox processes, as has been observed previously for other thioredoxins.^{44,45} Considering the two-electron redox nature of the thiol to disulfide transformation, the broadening of the peaks of the voltammograms may suggest that different MbNrdH conformations exist on the electrode surface under the experimental conditions, which has been observed previously.^{44,45}

The thiol to disulfide transformation is also a proton-coupled process, and thus, the potentials of thioredoxins are highly dependent on the pH. To investigate the pH dependence, the reduction potentials of MbNrdH were determined across a pH range of 4.5–9.5 (Figure 4B). A linear fit of all data points gave a slope of -53.2 mV/pH unit (-56.8 mV/pH unit for a fit of only the pH range of 4.5–7.0), implying a one- H^+ /one- e^- or two- H^+ /two- e^- process (the theoretical slope for such processes is -59 mV/pH unit).

From the half-height widths of the peaks and the pH dependence of the reduction potentials, we conclude that the

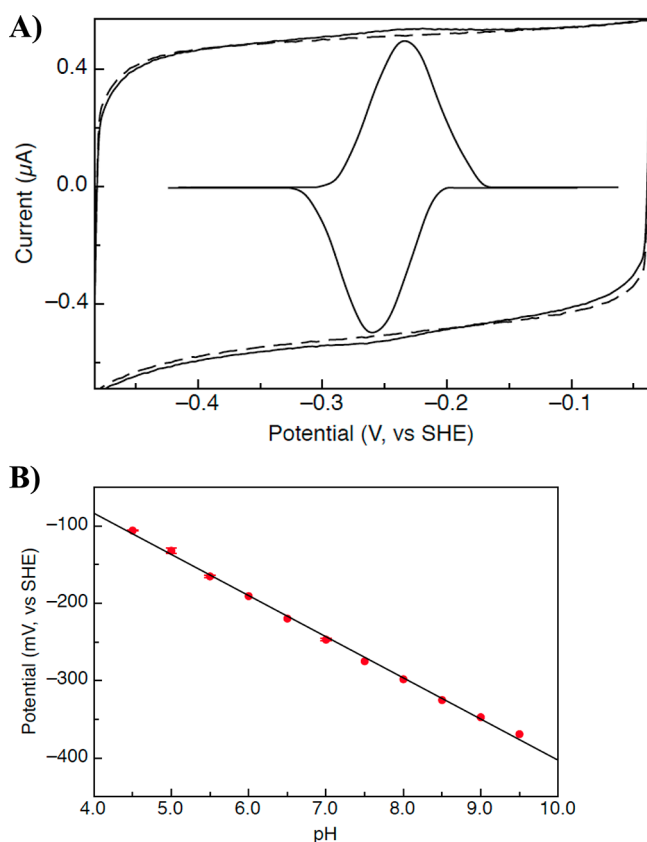

Figure 4. (A) Example of PFV analysis of MbNrdH at pH 7.0 and 25 °C. The dashed line is the background capacitance of the blank working electrode. The solid line shows the raw data with MbNrdH on the electrode. The two reversible peaks of the inset were obtained from background subtraction. The reduction potential (E_m) of MbNrdH is determined by averaging the potential values of the two peaks. SHE is the standard hydrogen electrode. (B) pH dependence of the MbNrdH reduction potential at 25 °C. MbNrdH reduction potentials at different pH values were fitted to a linear model ($E_m = 129.4 - 53.2 \times \text{pH}$ unit).

voltammograms from this study represent a redox couple approaching a two- H^+ /two- e^- redox process, characteristic of a thioredoxin cycling between the fully reduced (-SH HS-) and fully oxidized (-S-S-) states. The potential of MbNrdH (-250 mV) is close to that reported for *E. coli* TrxA (-270 mV)⁴⁶ and for *E. coli* NrdH (-248.5 mV),¹³ the reductant of *E. coli* class Ib RNR, suggesting that MbNrdH has an appropriate potential for supporting nucleotide reduction.

MbNrdH Is Required for Nucleotide Reduction by MbNrdD Using DTT as an Electron Source. To establish whether NrdH can support nucleotide reduction by NrdD3, we conducted assays using MbNrdD (0.1 G^*/α), MbNrdH, and DTT as an electron source, and the results are summarized in Table 2. MbNrdD was active for reduction of CTP to dCTP with ATP as an effector, but much less active for CDP reduction [$\sim 10\%$ of the activity for CTP reduction (Table 2)]. This promiscuous activity was also previously observed for *N. bacilliformis* NrdD2.³ Catalytic activity was dependent on the presence of G^* and MbNrdH (Table 2). As with *N. bacilliformis* NrdD2, DTT alone fails to efficiently reduce MbNrdD in the absence of MbNrdH, and formate failed to produce any dCTP. MbNrdH could not be replaced by MbTrxA, or by MbMRX.²⁶ Thus, the experiments demonstrate that the specific redoxin

Table 2. Requirements for dCTP Formation by MbNrdD Using DTT as the Electron Source^a

reaction conditions	activity (units/mg)
complete (CTP, ATP)	55 ± 3
-SAM (no G^* formed)	ND
-NrdH	ND
-NrdH + TrxA	ND
-NrdH + MRX	ND
-DTT	ND
-DTT + formate (10 mM)	ND
-DTT + TrxB (1 μM) + NADPH (2 mM)	ND
-ATP	22 ± 1
-ATP + dATP (0.1 mM)	47 ± 2
-CTP + CDP (0.5 mM)	6 ± 1

^aND, activity not detected, <10 turnovers per G^* over 20 min.

MbNrdH is required for nucleotide reduction by MbNrdD with DTT as the electron source.

CTP reduction activity was enhanced 2.5-fold by ATP and 2-fold by dATP (Table 2). MbNrdD has an annotated N-terminal ATP cone domain, which controls the activity of many RNRs by binding the activator (ATP) or the inactivator (dATP). However, in MbNrdD, this domain lacks conserved residues required for nucleotide binding and is thus predicted to be inactive.^{47,48} In MbNrdD, both ATP and dATP are predicted to bind to the specificity site and activate nucleotide reduction. The degree of activation is smaller than that observed in *E. coli* NrdD (5-fold enhancement of CTP reduction by ATP).⁴⁹

The MbTrxB/NADPH system failed to replace DTT as the electron source, demonstrating that MbNrdH is not a substrate for MbTrxB. This is consistent with the observation that bacterial and archaeal TrxB are highly specific for their cognate TrxA.⁵⁰ Also, TrxB sequences are not highly conserved among methanogens containing NrdD3, and it was noted that the *Methanosarcina* TrxBs are more closely related to that of sulfate-reducing bacteria than to that of other methanogens.⁴⁰ As a control to verify the activity of the recombinant *M. barkeri* thioredoxin system, MbTrxB is active for DTNB reduction (3.4 $\mu\text{M min}^{-1} \text{mg}^{-1}$), and the MbTrxA/MbTrxB/NADPH system can provide electrons for CTP reduction by *L. leichmannii* NrdJ⁴² (200 units/mg).

Identification of FDR as a Candidate Reductant for NrdH Using Bioinformatics. Having established that NrdH can supply electrons for nucleotide reduction by NrdD3, we next sought the source of electrons for reduction of NrdH. We previously noted that the NADPH-dependent NrdD2, present in anaerobic bacteria and archaea with a large variety of metabolic types, is uncommon in methanogens, which instead use NrdD1 or NrdD3.³ A possible reason is that unlike in most other types of energy metabolism, NADH and NADPH are not used as electron carriers in methanogenesis. This and the inability of the MbTrxB/NADPH system to deliver electrons to MbNrdD through MbNrdH lead us to propose that the source of electrons for NrdD3 is one of the electron carriers used in methanogenesis. Possible candidates for the source of electrons for reduction of NrdH [-250 mV (see above)] are Fdx (-420 mV)⁵¹ and coenzyme F_{420} (-360 mV).⁵²

M. barkeri and other organisms in the order Methanosarcinales can generate methane from methanol or methylamines [methylotrophic methanogenesis (Figure 5A)] or from acetate [acetoclastic methanogenesis (Figure 5B)]. These pathways differ in the electron carriers used in energy conservation

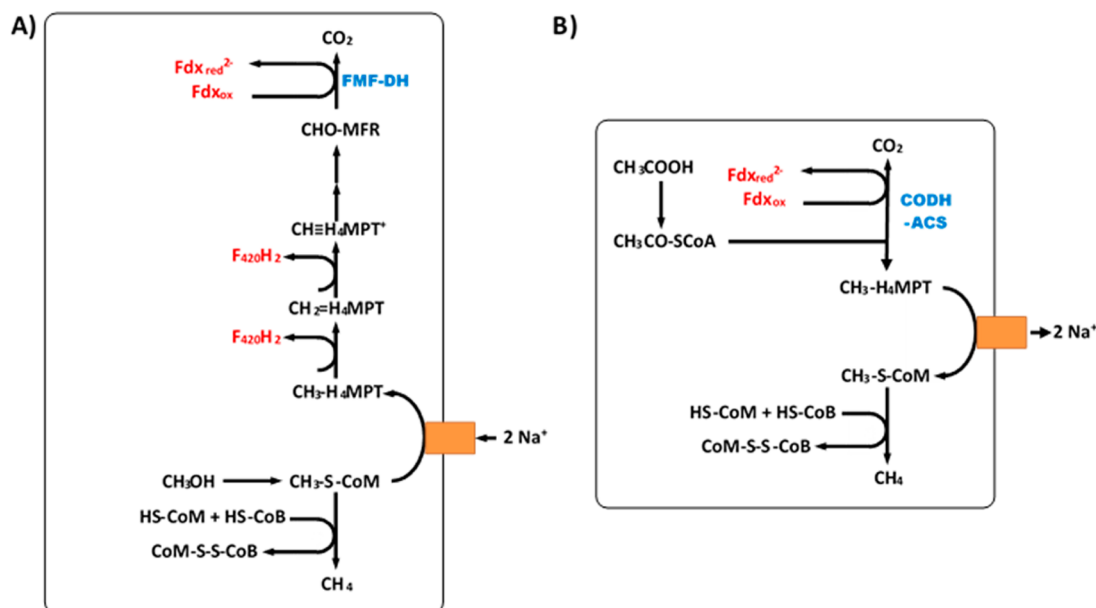

Figure 5. Pathways for methanogenesis from methanol or acetate. (A) In methylo-trophic methanogenesis, oxidation of each methyl group produces four electrons in the form of F_{420}H_2 from the oxidation of methyl- and methylene-tetrahydromethanopterin (H_4MPT) and two electrons in the form of reduced Fdx from the oxidation of the formyl group to CO_2 by formylmethanofuran dehydrogenase (FMF-DH). (B) In aceticlastic methanogenesis, breakdown of each acetate molecule produces two electrons in the form of reduced Fdx from the carbon monoxide dehydrogenase/acetyl CoA synthase system (CODH/ACS).⁵³

(Figure 5), allowing us to examine the distribution of class III RNRs among the metabolically diverse Methanosarcinales for clues regarding the source of electrons for reduction of NrdH (Table 3).

Table 3. Occurrence of RNRs, FDR1, and FDR2 in Sequenced Methanosarcinales

organism	substrates	RNRs	FDR1 and/or FDR2
<i>Methanosarcina</i> ^{43,54}	methanol, methylamines, acetate, $\text{H}_2 + \text{CO}_2$	NrdD3, NrdJ	FDR1, FDR2
<i>Methanohalophilus</i> ⁵⁵ and <i>Methanohalobium</i>	methanol, methylamines	NrdD3, NrdJ	FDR1
<i>Methanococcoides</i> , ⁵⁶ <i>Methanosalsum</i> , and <i>Methanolobus</i> ⁵⁷	methanol, methylamines	NrdD3, NrdD2	FDR1
<i>Methanosaeta</i> ⁵⁸	acetate	NrdD3, NrdJ	FDR2

Most class II methanogens contain NrdD3 and NrdJ. Among the Methanosarcinales, this combination is present in the aceticlastic *Methanosaeta* and metabolically versatile *Methanosarcina* species (Table 3). In contrast, some obligate methylotrophs (*Methanococcoides*, *Methanosalsum*, and *Methanolobus*) lack NrdJ and instead contain NrdD3 and NrdD2 (Table 3). In methanogens, NADPH required for biosynthesis can be generated reversibly from F_{420}H_2 using the cytosolic enzyme $\text{F}_{420}\text{-NADP}^+$ reductase,⁵⁹ and the presence of the NADPH-dependent NrdD2 in obligate methylotrophs may reflect their obligate production of F_{420}H_2 (Figure 5A). Conversely, we propose that the presence of NrdD3 in all Methanosarcinales may reflect its dependence on the universally produced reduced Fdx (Figure 5A,B).

Next, we sought a pathway for Fdx-dependent reduction of NrdH. For thioredoxin reduction, an alternative to the flavin-

containing thioredoxin reductase TrxB, which obtains electrons from NADPH, is the plant-type [4Fe-4S] cluster-containing FTR, which obtains electrons from plant Fdx.²⁵ FTR-like proteins have been classified into several subtypes according to their primary sequence,⁶⁰ and two of these subtypes (FDR1 and FDR2) are broadly distributed in Methanosarcinales (Table 3). Methylo-trophic methanogens contain FDR1, which is located in the genome adjacent to FMF-DH, a source of reduced Fdx (Figure 5A). Aceticlastic methanogens contain the recently characterized FDR2,²⁴ and CODH/ACS provides a possible source of reduced Fdx (Figure 5B). Metabolically versatile *Methanosarcina* species contain both FDR1 and FDR2.

FDR1 Supports Nucleotide Reduction by MbNrdD Using Ti(III) Citrate as an Electron Source. To determine whether a FDR can provide electrons for nucleotide reduction, we conducted assays using MbNrdD (0.1 G^*/α), MbNrdH, and MbFDR1. To avoid the additional complexities of a Fdx-regenerating system, the one-electron reductant Ti(III) citrate was used as a surrogate for reduced Fdx (see Figure 2), and the results are summarized in Table 4. The catalytic activity for nucleotide reduction with the NrdH/FDR1/Ti(III) system is comparable to that of the NrdH/DTT system and is dependent on the presence of both NrdH and FDR1 (Table 4). The number of dCTPs formed per Ti(III) in the reaction mixture is 0.45 (Figure 6), consistent with a 1:2 stoichiometry and demonstrating that the reducing equivalents come from Ti(III).

Table 4. Requirements for dCTP Formation by MbNrdD Using Ti(III) Citrate as the Electron Source^a

reaction conditions	activity (units/mg)
complete (CTP, ATP)	41 ± 1
-NrdH	ND
-FDR1	ND

^aND, activity not detected, <10 turnovers per G^* over 20 min.

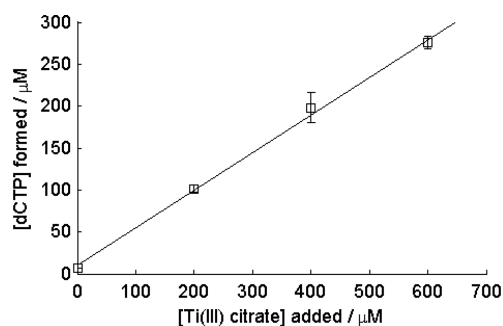

Figure 6. Amount of 5- ^3H dCTP formed after incubation of MbNrdD with 5- ^3H CTP, dATP, NrdH, FDR1, and limiting amounts of Ti(III) citrate at 30 °C for 2 h. The stoichiometry of dCTP produced per Ti(III) added is 0.45. The concentration of MbNrdD G $^{\circ}$ in the reaction is $\sim 1 \mu\text{M}$.

We also conducted assays with *M. acetivorans* FDR2²⁴ (MaFDR2, 86% sequence identity between *M. acetivorans* and *M. barkeri* FDR2), using assay conditions identical to those used for FDR1, but did not detect significant activity (<20 turnovers over 1 h). It is possible that either FDR2 does not deliver electrons for NrdD3 in this organism or our assay conditions with Ti(III) citrate do not support FDR2 activity. Further studies are required to determine whether FDR2 can deliver electrons for NrdD3 in other organisms, such as *Methanosaeta*, that lack FDR1.

DISCUSSION

The [4Fe-4S] protein FTR was first studied in plants and cyanobacteria,²⁵ where it plays a regulatory role in CO₂ fixation. A recent bioinformatics study showed that FTR-like proteins are present in diverse nonphotosynthetic bacteria and archaea, where they have an unknown function.⁶⁰ Our experiments with the *M. barkeri* class III RNR demonstrate a new biosynthetic role for a FTR-like protein, FDR1, in providing electrons for anaerobic ribonucleotide reduction.

The potential measured for MbNrdH (−250 mV) suggests that the driving force for nucleotide reduction using electrons from Fdx (−420 mV)⁵¹ is much larger than required. However, because nucleotide reduction accounts for a minute fraction of the energy expenditure of the cell, there may not be strong selection to maximize the energetic efficiency of this reaction. Low-potential Fdx drives a variety of biosynthetic reactions in anaerobic organisms, and its use as an electron source could serve as a means to synchronize RNR activity with metabolic activity, a function similar to the allosteric activation of other RNRs by ATP.⁴

The link between RNR and metabolism may be informative with regard to ecologically important archaea, such as relatives of methanogens that conduct anaerobic methane oxidation, which have been difficult to culture and study. Of the anaerobic methanotrophs for which genomic or metagenomic information is available, ANME-2a⁶¹ and ANME-2d⁶² contain NrdD3, NrdJ, and one or more FDRs, similar to related class II methanogens. In contrast, ANME-1⁶³ contains NrdD2, NrdJ, and no FDR, suggesting different roles for Fdx in the metabolism of these organisms.

Apart from the unique electron source used by NrdD3, the configuration of its active-site residues is also remarkable (Figure 1D). The complex chemical mechanism of redoxin-dependent RNRs is thought to depend on acid/base catalysis by a conserved active-site Glu residue,⁷ and replacement of this

residue in *E. coli* NrdA(E441Q) leads to accumulation of radical intermediates and failure to complete the catalytic cycle.⁶⁴ Our observation that NrdD3 conducts NrdH-dependent nucleotide reduction provides evidence of mechanistic similarities with the redoxin-dependent class I and II RNRs and NrdD2, despite the absence of a conserved active-site acid/base residue. Further investigations of this enzyme could lead to a deeper understanding of the mechanism of ribonucleotide reduction.

ASSOCIATED CONTENT

Supporting Information

The Supporting Information is available free of charge on the ACS Publications website at DOI: 10.1021/acs.biochem.5b01092.

Yields, extinction coefficients, and SDS-PAGE gels for purification of recombinant proteins (PDF)

AUTHOR INFORMATION

Corresponding Authors

*E-mail: yifwei@mit.edu. Telephone: (617) 253-0084.

*E-mail: stubbe@mit.edu. Telephone: (617) 253-1814.

Funding

This work was supported by ASTAR Singapore (Y.W.); the Division of Chemical Sciences, Geosciences, and Biosciences, Office of Basic Energy Sciences, U.S. Department of Energy, via Contract DE-FG02-95ER20198 MOD16 (J.G.F.); National Science Foundation Grant MCB 1122977 (S.J.E.); and National Institutes of Health Grant GM081393 (J.S.).

Notes

The authors declare no competing financial interest.

ACKNOWLEDGMENTS

We thank Prof. William W. Metcalf for the gift of *M. barkeri* genomic DNA and Dr. Silvan Scheller and Yuen Lai Shek for helpful discussions.

REFERENCES

- Reichard, P. (1993) The anaerobic ribonucleotide reductase from *Escherichia coli*. *J. Biol. Chem.* 268, 8383–8386.
- Mulliez, E., Ollagnier, S., Fontecave, M., Eliasson, R., and Reichard, P. (1995) Formate is the hydrogen donor for the anaerobic ribonucleotide reductase from *Escherichia coli*. *Proc. Natl. Acad. Sci. U. S. A.* 92, 8759–8762.
- Wei, Y., Funk, M. A., Rosado, L. A., Baek, J., Drennan, C. L., and Stubbe, J. (2014) The class III ribonucleotide reductase from *Neisseria bacilliformis* can utilize thioredoxin as a reductant. *Proc. Natl. Acad. Sci. U. S. A.* 111, E3756–E3765.
- Nordlund, P., and Reichard, P. (2006) Ribonucleotide reductases. *Annu. Rev. Biochem.* 75, 681–706.
- Hofer, A., Crona, M., Logan, D. T., and Sjöberg, B.-M. (2012) DNA building blocks: keeping control of manufacture. *Crit. Rev. Biochem. Mol. Biol.* 47, 50–63.
- Licht, S., Gerfen, G. J., and Stubbe, J. (1996) Thiyl radicals in ribonucleotide reductases. *Science* 271, 477–481.
- Licht, S., and Stubbe, J. (1999) in *Comprehensive Natural Products Chemistry* (Barton, S., Nakanishi, K., Meth-Cohn, O., and Poulter, C., Eds.) p 163, Elsevier Science, New York.
- Stubbe, J. (1998) Ribonucleotide reductases in the twenty-first century. *Proc. Natl. Acad. Sci. U. S. A.* 95, 2723–2724.
- Sun, X., Ollagnier, S., Schmidt, P. P., Atta, M., Mulliez, E., Lepape, L., Eliasson, R., Graslund, A., Fontecave, M., Reichard, P., and Sjöberg, B. M. (1996) The free radical of the anaerobic ribonucleotide reductase from *Escherichia coli* is at glycine 681. *J. Biol. Chem.* 271, 6827–6831.

- (10) Gambarelli, S., Luttringer, F., Padovani, D., Mulliez, E., and Fontecave, M. (2005) Activation of the anaerobic ribonucleotide reductase by S-adenosylmethionine. *ChemBioChem* 6, 1960–1962.
- (11) Mao, S. S., Holler, T. P., Yu, G. X., Bollinger, J. M., Jr., Booker, S., Johnston, M. I., and Stubbe, J. (1992) A model for the role of multiple cysteine residues involved in ribonucleotide reduction: amazing and still confusing. *Biochemistry* 31, 9733–9743.
- (12) Holmgren, A. (1979) Glutathione-dependent synthesis of deoxyribonucleotides. Characterization of the enzymatic mechanism of *Escherichia coli* glutaredoxin. *J. Biol. Chem.* 254, 3672–3678.
- (13) Jordan, A., Åslund, F., Pontis, E., Reichard, P., and Holmgren, A. (1997) Characterization of *Escherichia coli* NrdH: A glutaredoxin-like protein with a thioredoxin-like activity profile. *J. Biol. Chem.* 272, 18044–18050.
- (14) Avval, F. Z., and Holmgren, A. (2009) Molecular Mechanisms of Thioredoxin and Glutaredoxin as Hydrogen Donors for Mammalian S Phase Ribonucleotide Reductase. *J. Biol. Chem.* 284, 8233–8240.
- (15) Logan, D. T., Andersson, J., Sjöberg, B.-M., and Nordlund, P. (1999) A Glycyl Radical Site in the Crystal Structure of a Class III Ribonucleotide Reductase. *Science* 283, 1499–1504.
- (16) Wei, Y., Mathies, G., Yokoyama, K., Chen, J., Griffin, R. G., and Stubbe, J. (2014) A Chemically Competent Thiosulfuranyl Radical on the *Escherichia coli* Class III Ribonucleotide Reductase. *J. Am. Chem. Soc.* 136, 9001–9013.
- (17) Aurelius, O., Johansson, R., Bågenholm, V., Lundin, D., Tholander, F., Balhuizen, A., Beck, T., Sahlin, M., Sjöberg, B.-M., Mulliez, E., and Logan, D. T. (2015) The Crystal Structure of *Thermotoga maritima* Class III Ribonucleotide Reductase Lacks a Radical Cysteine Pre-Positioned in the Active Site. *PLoS One* 10, e0128199.
- (18) Larsson, K.-M., Jordan, A., Eliasson, R., Reichard, P., Logan, D. T., and Nordlund, P. (2004) Structural mechanism of allosteric substrate specificity regulation in a ribonucleotide reductase. *Nat. Struct. Mol. Biol.* 11, 1142–1149.
- (19) Knappe, J., and Sawers, G. (1990) A radical-chemical route to acetyl-CoA: the anaerobically induced pyruvate formate-lyase system of *Escherichia coli*. *FEMS Microbiol. Lett.* 75, 383–398.
- (20) Bapteste, É., Brochier, C., and Boucher, Y. (2005) Higher-level classification of the Archaea: evolution of methanogenesis and methanogens. *Archaea* 1, 353–363.
- (21) White, R. H. (1997) Purine biosynthesis in the domain Archaea without folates or modified folates. *J. Bacteriol.* 179, 3374–3377.
- (22) Costa, K. C., Wong, P. M., Wang, T., Lie, T. J., Dodsworth, J. A., Swanson, I., Burn, J. A., Hackett, M., and Leigh, J. A. (2010) Protein complexing in a methanogen suggests electron bifurcation and electron delivery from formate to heterodisulfide reductase. *Proc. Natl. Acad. Sci. U. S. A.* 107, 11050–11055.
- (23) Thauer, R. K., Kaster, A.-K., Seedorf, H., Buckel, W., and Hedderich, R. (2008) Methanogenic archaea: ecologically relevant differences in energy conservation. *Nat. Rev. Microbiol.* 6, 579–591.
- (24) Kumar, A. K., Kumar, R. S. S., Yennawar, N. H., Yennawar, H. P., and Ferry, J. G. (2015) Structural and Biochemical Characterization of a Ferredoxin:Thioredoxin Reductase-like Enzyme from *Methanosarcina acetivorans*. *Biochemistry* 54, 3122–3128.
- (25) Staples, C. R., Ameyibor, E., Fu, W., Gardet-Salvi, L., Stritt-Etter, A.-L., Schürmann, P., Knaff, D. B., and Johnson, M. K. (1996) The function and properties of the iron-sulfur center in spinach ferredoxin: thioredoxin reductase: a new biological role for iron-sulfur clusters. *Biochemistry* 35, 11425–11434.
- (26) Yenugdhati, D., Prakash, D., Kumar, A. K., Kumar, R. S. S., Yennawar, N. H., Yennawar, H. P., and Ferry, J. G. (2015) manuscript submitted for publication.
- (27) Russel, M., and Model, P. (1985) Direct cloning of the *trxB* gene that encodes thioredoxin reductase. *J. Bacteriol.* 163, 238–242.
- (28) Chivers, P. T., Prehoda, K. E., Volkman, B. F., Kim, B.-M., Markley, J. L., and Raines, R. T. (1997) Microscopic pKa values of *Escherichia coli* thioredoxin. *Biochemistry* 36, 14985–14991.
- (29) Seefeldt, L. C., and Ensign, S. (1994) A continuous, spectrophotometric activity assay for nitrogenase using the reductant titanium (III) citrate. *Anal. Biochem.* 221, 379–386.
- (30) Gibson, D. G., Young, L., Chuang, R.-Y., Venter, J. C., Hutchison, C. A., and Smith, H. O. (2009) Enzymatic assembly of DNA molecules up to several hundred kilobases. *Nat. Methods* 6, 343–345.
- (31) Fox, J. D., Rutzahn, K. M., Bucher, M. H., and Waugh, D. S. (2003) Maltodextrin-binding proteins from diverse bacteria and archaea are potent solubility enhancers. *FEBS Lett.* 537, 53–57.
- (32) Howard, R. J., Clark, K. A., Holton, J. M., and Minor, D. L. (2007) Structural insight into KCNQ (Kv7) channel assembly and channelopathy. *Neuron* 53, 663–675.
- (33) Booker, S., and Stubbe, J. (1993) Cloning, sequencing, and expression of the adenosylcobalamin-dependent ribonucleotide reductase from *Lactobacillus leichmannii*. *Proc. Natl. Acad. Sci. U. S. A.* 90, 8352–8356.
- (34) Luttringer, F., Mulliez, E., Dublet, B., Lemaire, D., and Fontecave, M. (2009) The Zn center of the anaerobic ribonucleotide reductase from *E. coli*. *JBIC, J. Biol. Inorg. Chem.* 14, 923–933.
- (35) Fish, W. (1988) Rapid colorimetric micromethod for the quantitation of complexed iron in biological samples. *Methods Enzymol.* 158, 357.
- (36) Malmström, B. G., Reinhammar, B., and Vångård, T. (1970) The state of copper in stellacyanin and laccase from the lacquer tree *Rhus vernicifera*. *Biochim. Biophys. Acta, Bioenerg.* 205, 48–57.
- (37) Steeper, J., and Steuart, C. (1970) A rapid assay for CDP reductase activity in mammalian cell extracts. *Anal. Biochem.* 34, 123–130.
- (38) Fourmond, V., Hoke, K., Heering, H. A., Baffert, C., Leroux, F., Bertrand, P., and Léger, C. (2009) SOAS: A free program to analyze electrochemical data and other one-dimensional signals. *Bioelectrochemistry* 76, 141–147.
- (39) Williams, C. H., Zanetti, G., Arscott, L. D., and McAllister, J. K. (1967) Lipoamide Dehydrogenase, Glutathione Reductase, Thioredoxin Reductase, and Thioredoxin. *J. Biol. Chem.* 242, 5226–5231.
- (40) McCarver, A. C., and Lessner, D. J. (2014) Molecular characterization of the thioredoxin system from *Methanosarcina acetivorans*. *FEBS J.* 281, 4598–4611.
- (41) Arnér, E. S., and Holmgren, A. (2001) Measurement of thioredoxin and thioredoxin reductase. *Curr. Protoc. Toxicol.*, 7.4.1–7.4.14.
- (42) Booker, S., Licht, S., Broderick, J., and Stubbe, J. (1994) Coenzyme B12-dependent ribonucleotide reductase: evidence for the participation of five cysteine residues in ribonucleotide reduction. *Biochemistry* 33, 12676–12685.
- (43) Maeder, D. L., Anderson, I., Brettin, T. S., Bruce, D. C., Gilna, P., Han, C. S., Lapidus, A., Metcalf, W. W., Saunders, E., Tapia, R., and Sowers, K. R. (2006) The *Methanosarcina barkeri* genome: comparative analysis with *Methanosarcina acetivorans* and *Methanosarcina mazei* reveals extensive rearrangement within Methanosarcinal genomes. *J. Bacteriol.* 188, 7922–7931.
- (44) Chobot, S. E., Hernandez, H. H., Drennan, C. L., and Elliott, S. J. (2007) Direct electrochemical characterization of archaeal thioredoxins. *Angew. Chem.* 119, 4223–4225.
- (45) Bewley, K. D., Dey, M., Bjork, R. E., Mitra, S., Chobot, S. E., Drennan, C. L., and Elliott, S. J. (2015) Rheostat Re-Wired: Alternative Hypotheses for the Control of Thioredoxin Reduction Potentials. *PLoS One* 10, e0122466.
- (46) Krause, G., Lundström, J., Barea, J. L., Pueyo de la Cuesta, C., and Holmgren, A. (1991) Mimicking the active site of protein disulfide-isomerase by substitution of proline 34 in *Escherichia coli* thioredoxin. *J. Biol. Chem.* 266, 9494–9500.
- (47) Aravind, L., Wolf, Y. I., and Koonin, E. V. (2000) The ATP-cone: an evolutionarily mobile, ATP-binding regulatory domain. *J. Mol. Microbiol. Biotechnol.* 2, 191–194.
- (48) Fairman, J. W., Wijerathna, S. R., Ahmad, M. F., Xu, H., Nakano, R., Jha, S., Prendergast, J., Welin, R. M., Flodin, S., Roos, A., Nordlund, P., Li, Z., Walz, T., and Dealwis, C. G. (2011) Structural basis for

allosteric regulation of human ribonucleotide reductase by nucleotide-induced oligomerization. *Nat. Struct. Mol. Biol.* 18, 316–322.

(49) Eliasson, R., Pontis, E., Sun, X., and Reichard, P. (1994) Allosteric control of the substrate specificity of the anaerobic ribonucleotide reductase from *Escherichia coli*. *J. Biol. Chem.* 269, 26052–26057.

(50) Arnér, E. S., and Holmgren, A. (2000) Physiological functions of thioredoxin and thioredoxin reductase. *Eur. J. Biochem.* 267, 6102–6109.

(51) Grahame, D. A. (1991) Catalysis of acetyl-CoA cleavage and tetrahydrosarcinapterin methylation by a carbon monoxide dehydrogenase-corrinoid enzyme complex. *J. Biol. Chem.* 266, 22227–22233.

(52) Walsh, C. (1986) Naturally occurring 5-deazaflavin coenzymes: biological redox roles. *Acc. Chem. Res.* 19, 216–221.

(53) Ferry, J. G. (1999) Enzymology of one-carbon metabolism in methanogenic pathways. *FEMS Microbiol. Rev.* 23, 13–38.

(54) Galagan, J. E., Nusbaum, C., Roy, A., Endrizzi, M. G., Macdonald, P., FitzHugh, W., Calvo, S., Engels, R., Smirnov, S., and Atnoor, D. (2002) The genome of *M. acetivorans* reveals extensive metabolic and physiological diversity. *Genome Res.* 12, 532–542.

(55) Spring, S., Scheuner, C., Lapidus, A., Lucas, S., Glavina Del Rio, T., Tice, H., Copeland, A., Cheng, J.-F., Chen, F., and Nolan, M. (2010) The genome sequence of *Methanohalophilus mahii* SLP T reveals differences in the energy metabolism among members of the Methanosarcinaceae inhabiting freshwater and saline environments. *Archaea* 2010, 1.

(56) Allen, M. A., Lauro, F. M., Williams, T. J., Burg, D., Siddiqui, K. S., De Francisci, D., Chong, K. W. Y., Pilak, O., Chew, H. H., De Maere, M. Z., Ting, L., Katrib, M., Ng, C., Sowers, K. R., Galperin, M. Y., Anderson, I. J., Ivanova, N., Dalin, E., Martinez, M., Lapidus, A., Hauser, L., Land, M., Thomas, T., and Cavicchioli, R. (2009) The genome sequence of the psychrophilic archaeon, *Methanococoides burtonii*: the role of genome evolution in cold adaptation. *ISME J.* 3, 1012–1035.

(57) Chen, Z., Yu, H., Li, L., Hu, S., and Dong, X. (2012) The genome and transcriptome of a newly described psychrophilic archaeon, *Methanobolus psychrophilus* R15, reveal its cold adaptive characteristics. *Environ. Microbiol. Rep.* 4, 633–641.

(58) Barber, R. D., Zhang, L., Harnack, M., Olson, M. V., Kaul, R., Ingram-Smith, C., and Smith, K. S. (2011) Complete Genome Sequence of *Methanosaeta concilii*, a Specialist in Aceticlastic Methanogenesis. *J. Bacteriol.* 193, 3668–3669.

(59) Dudleyeirich, L., and Dugger, R. S. (1984) Purification and properties of an F₄₂₀-dependent NADP reductase from *Methanobacterium thermoautotrophicum*. *Biochim. Biophys. Acta, Gen. Subj.* 802, 454–458.

(60) Balsera, M., Uberegui, E., Susanti, D., Schmitz, R. A., Mukhopadhyay, B., Schürmann, P., and Buchanan, B. B. (2013) Ferredoxin: thioredoxin reductase (FTR) links the regulation of oxygenic photosynthesis to deeply rooted bacteria. *Planta* 237, 619–635.

(61) Wang, F.-P., Zhang, Y., Chen, Y., He, Y., Qi, J., Hinrichs, K.-U., Zhang, X.-X., Xiao, X., and Boon, N. (2014) Methanotrophic archaea possessing diverging methane-oxidizing and electron-transporting pathways. *ISME J.* 8, 1069–1078.

(62) Haroon, M. F., Hu, S., Shi, Y., Imelfort, M., Keller, J., Hugenholtz, P., Yuan, Z., and Tyson, G. W. (2013) Anaerobic oxidation of methane coupled to nitrate reduction in a novel archaeal lineage. *Nature* 500, 567–570.

(63) Michaelis, W., Seifert, R., Nauhaus, K., Treude, T., Thiel, V., Blumenberg, M., Knittel, K., Gieseke, A., Peterknecht, K., and Pape, T. (2002) Microbial reefs in the Black Sea fueled by anaerobic oxidation of methane. *Science* 297, 1013–1015.

(64) Lawrence, C. C., Bennati, M., Obias, H. V., Bar, G., Griffin, R. G., and Stubbe, J. (1999) High-field EPR detection of a disulfide radical anion in the reduction of cytidine 5'-diphosphate by the E441Q R1 mutant of *Escherichia coli* ribonucleotide reductase. *Proc. Natl. Acad. Sci. U. S. A.* 96, 8979–8984.