

Distribution transformer lifetime analysis in the presence of demand response and rooftop PV integration

Behnaz Behi¹, Ali Arefi^{1*}, Houman Pezeshki², Farhad Shahnia¹

¹School of Engineering and Information Technology, Murdoch University

²School of Electrical Engineering and Computer Science, Queensland University of Technology

* Email: a.arefi@murdoch.edu.au, ali.aarefi@gmail.com

Abstract

Many distribution transformers have already exceeded half of their expected service life of 35 years in the infrastructure of Western Power, the electric distribution company supplying south west of Western Australia, Australia. Therefore, it is anticipated that a high investment on transformer replacement happens in the near future. However, high renewable integration and demand response are promising resources to defer the investment on infrastructure upgrade and extend the lifetime of transformers. This paper investigates the impact of rooftop photovoltaic (PV) integration and customer engagement through demand response (DR) on the lifetime of transformers in electric distribution networks. To this aim, first, a time series modelling of load, DR and PV is utilised for each year over a planning period. This load model is applied to a typical distribution transformer for which the hot-spot temperature rise is modelled based on the relevant standard. Using this calculation platform, the loss of life and the actual age of distribution transformer are obtained. Then, various scenarios including different levels of PV penetration and DR contribution are examined, and their impacts on the age of transformer are reported. Finally, the equivalent loss of net present value of distribution transformer is formulated and discussed. This formulation gives major benefits to the distribution network planners for analysing the contribution of PV and demand response on lifetime extension of the distribution transformer. In addition, the provided model can be utilised in optimal investment analysis to find the best time for the transformer replacement and the associated cost considering PV penetration and DR. The simulation results show that integration of PV and DR within a feeder can significantly extend the lifetime of transformers.

Keywords: Distribution transformer, lifetime, demand response, rooftop PV

1. Introduction

Distribution transformers are one of the main components of electric distribution systems and have an average expected lifetime of 35 years. Many distribution transformers have already exceeded half of their expected service life. This figure for Western Power's infrastructure (the electric distribution company supplying south west of Western Australia, Australia) is noticeably higher than other utilities when it comes to distribution transformers (Sharafi, 2010), resulting in a high investment on transformer replacement in the near future. Therefore, assessing and managing the lifetime of transformers is a very important task for utilities (Zhang et al., 2008), especially, when considering emerging technologies in distribution networks. On the other hand, many nations have already set renewable energy targets, for example in Australia's electricity generation, a 23.5% contribution from renewables by 2020 is the target (Ministry for the Environment, et al., 2015). These targets along with cost reduction of rooftop photovoltaic (PV) systems encourage investors to install PVs and generate energy from them, resulting in a PV uptake rate of 60% per annum (REN21SteeringCommittee) in recent years. Although PV systems present some advantages to consumers and providers, high penetration of them develops some power quality problems such as current and voltage unbalance (Baran et al., 2012, Shahnia et al., 2012, Alam et al., 2014, Awadallah et al., 2015, Navarro-Espinosa et al., 2015). One of the disadvantage of load unbalance on a distribution transformer is the reduction of its useful lifetime (Moses et al., 2012, Pezeshki et al., 2014, Awadallah et al., 2015). On the other hand, the PV generation during peak time can reduce the load

(Hayat et al., 2016) and, consequently, extend the lifetime of distribution transformers. Therefore, the effect of load unbalances on the management of lifetime should take into account when assessing the lifetime of transformers. In addition, customer engagement is a promising approach to improve the efficiency and economics of energy delivery. This engagement is usually implemented through demand response (DR) programs, such as community-based and direct load control programs, resulting in postponing transformer upgrade through active consumer participation.

The lifetime of a distribution transformer is mainly determined by insulation life (Simoni, 1999) where itself is affected by the transformer loading including magnitude and quality, ambient temperature, and the moisture and the oxygen content of the oil (Crine, 2005). In order to achieve better performance for transformer investment, a correct utilisation of transformer considering loading, ambient temperature, and thermal characteristics is essential. To this aim, a prediction model is vital to estimate the winding hot-spot temperature (HST) and top-oil temperature (Swift et al., 2001). Moreover, the detail methodologies to calculate the HST is presented in IEEE Standard C57.91-1995 (2012) and IEC standard 60076-7 (IEC, 2005). The impact of different levels of PV and load unbalance on transformer lifetime is investigated in (Pezeshki et al., 2014) over one year. However, for a better understanding of financial advantage/disadvantage of PV and DR, it is important to analyse this effect over multi-year. This is because that electric distribution planning is carried out over multiyear with a horizon year of 5-10 years in distribution networks (Arefi et al.).

The load profile of a feeder, which is obtained based on individual consumption of customers, is the main factor to choose the distribution transformer and to manage its lifetime. Considering integration of PV and DR, this loading pattern will change. Therefore, different level of PV and DR penetration will contribute to different load profile and consequently, to different lifetime span of a distribution transformer. This paper presents a model to assess the impact of rooftop PV and DR on the transformer insulation life. A dynamic thermal model based on IEC 60076 is utilised for the estimation of the hot-spot temperature. Then, the insulation ageing is firstly investigated over a year for a distribution transformer supplying a residential low voltage (LV) feeder as explained in (Pezeshki et al., 2014). This feeder and the associated load data is obtained from the Perth Solar City High Penetration PV Trial (Perth Solar City, 2011). The ambient temperature data is included into the model to predict the lifetime span. The simulation results provided from (Pezeshki et al., 2014) is utilised to assess the equivalent of the net present value of transformer lifetime under different scenarios considering the different level of PV and DR penetration.

The paper is organised as follows. Next Section illustrates the proposed methodology for assessment of transformer lifetime. Simulation results are presented in Section 3 followed by relevant conclusions.

2. Methodology

In order to measure age deterioration of transformer's insulation, loss of life (LOL) parameter is defined as below (Pezeshki et al., 2014).

$$LOL = V_{EQA} \times t \quad (1)$$

where LOL is loss of life of transformer in days, and V_{EQA} is the equivalent aging factor over the time period of t , which is formulated as:

$$V_{EQA} = \frac{\sum_1^N V_n \Delta t_n}{\sum_1^N \Delta t_n} \quad (2)$$

where n is an index for the time interval t , N is the total number of time intervals, Δt_n is the time interval and V_n is aging acceleration factor for the time interval Δt_n . The aging acceleration factor for HST of θ_h for non-thermally upgraded paper (reference temperature of 98 °C) is defined as follows:

$$V_n = e^{\left[\frac{15000}{110+273} - \frac{15000}{\theta_h+273} \right]} \quad (3)$$

Hot-spot temperature (HST) model is based on IEC 60076, which is provided in (Pezeshki et al., 2014). This model uses time series data of loading per phase and ambient temperature to find θ_h and V_n at each time step. The detail of this procedure and the results are provided in (Pezeshki et al., 2014), and are not repeat here.

To evaluate the transformer lifetime, firstly, LOL at each year to horizon year should be calculated based on (1). Then, the equivalent net present value (NPV) of LOL over study period of H , namely NPV_{LOL} , is calculated as

$$NPV_{LOL} = \sum_{y=1}^H \frac{LOL_y \times NPV_y^{Trans}}{365} \quad (4)$$

This value is actually the equivalent NPV loss of the investment during planning period where LOL_y if the LOL of year y in days, 365 is the number of days of a year, and NPV_y^{Trans} is the NPV cost of distribution transformer for year y , which is obtained from

$$NPV_y^{Trans} = \frac{\text{Constant Annuity Value} = C_{Inv} \times CRF}{(1+r)^y} \quad (5)$$

where C_{Inv} is the investment cost of distribution transformer, r is the interest rate, and CRF is capital recovery factor, which is defined for a lifetime of Y years from

$$CRF = \frac{r(1+r)^Y}{(1+r)^Y - 1} \quad (6)$$

3. Simulation results

This section presents the evaluation of a distribution transformer lifetime based on the proposed methodology and considering different levels of PV and DR.

3.1 The case study

The considered study case is a three-phase low voltage (400 V line-line rms) feeder at Perth solar city , as shown in Figure 1 (Pezeshki et al., 2014). The installed distribution transformer is a three phase 200kVA Dyn 22 kV/400V, which supplies 77 residential consumers of the feeder. 34 consumers have rooftop PV systems with the average ratings of 1.88 kW, connected through new technologies (Shahnia et al., 2014). The total installed PV capacity at the time of data collection (2011-2012) was 64 kW representing a penetration of 32%. The loading profile of the transformer during summer peak period is depicted in Figure 2. As seen from this figure, this feeder has an unbalanced loading, e.g., the loading of phase B and C are much higher than the loading of phase A, which is mainly due to the non-monitored allocation of consumer connections among the three phases.

3.2 Simulation of Scenarios

Different scenarios, considering the different level of PV and loading of distribution transformer, are modelled and presented. It is important to note that unbalance condition of the feeder is taken into account in all scenarios to reflect the actual operation characteristic of the network. Also, an average load growth of 0.08 pu/yr is considered in these scenarios. The considered DR program in this analysis is a community-based DR, and is for peak shaving. The considered scenarios are:

Scenario-1. no PV and no DR;

Scenario-2: with PV, as described in Section 3.1, and no DR;

Scenario-3: with PV and 0.1 pu DR, which is applied from the second year of the planning period. The first year is for establishing a volunteer community-based DR program in that residential area.

The investment cost of a typical 200 kVA distribution transformer is assumed as AU\$45k (Abeygunawardana et al., 2014) which has a lifetime of 34 years. Considering an interest rate of 5%,

the constant annuity value of this transformer is AU\$2,748 based on Eq.(5) and (6). The NPV of the distribution transformer for each year during planning period (5 years), NPV_y^{Trans} , is provided in Table 1. As seen from this table, the NPV is higher for later years as effect of interest rate in higher as time goes on.

Table 2 to Table 4 present the LOL results and the equivalent cost for each scenario at each year over planning years based on the analyses carried out in (Pezeshki et al., 2014). The loading of the transformer in Scenario-1 increases 0.1 pu/year, realising 8% load growth over 5 years on average. This load growth is applied to other two scenarios as well. As seen from Table 2, the LOL of transformer increases when its loading becomes higher. For example, for the loading of 1.0 pu and 1.4 pu, the corresponding LOL is 20 and 4,486 days, respectively. The equivalent NPV at each year is calculated using the single term of Eq. (4), which is $LOL_y \times NPV_y^{Trans} / 365$. As seen, by overloading the transformer, the equivalent loss of NPV also becomes very high. For instance, for the loading of 1.0 pu and 1.4 pu, the corresponding NPV loss due to the LOL is AU\$143 and AU\$26,465, respectively. This results show that the LOL is 5,590 days during the planning period of 5 years, which means that the transformer will loss the equivalent useful lifetime of 15 years just during 5 years. In addition, the equivalent NPV loss for this transformer is about AU\$33k, which is about 75% of its investment cost. Therefore, it can be concluded that unbalance loading and overloading of a transformer significantly reduce its useful lifetime.

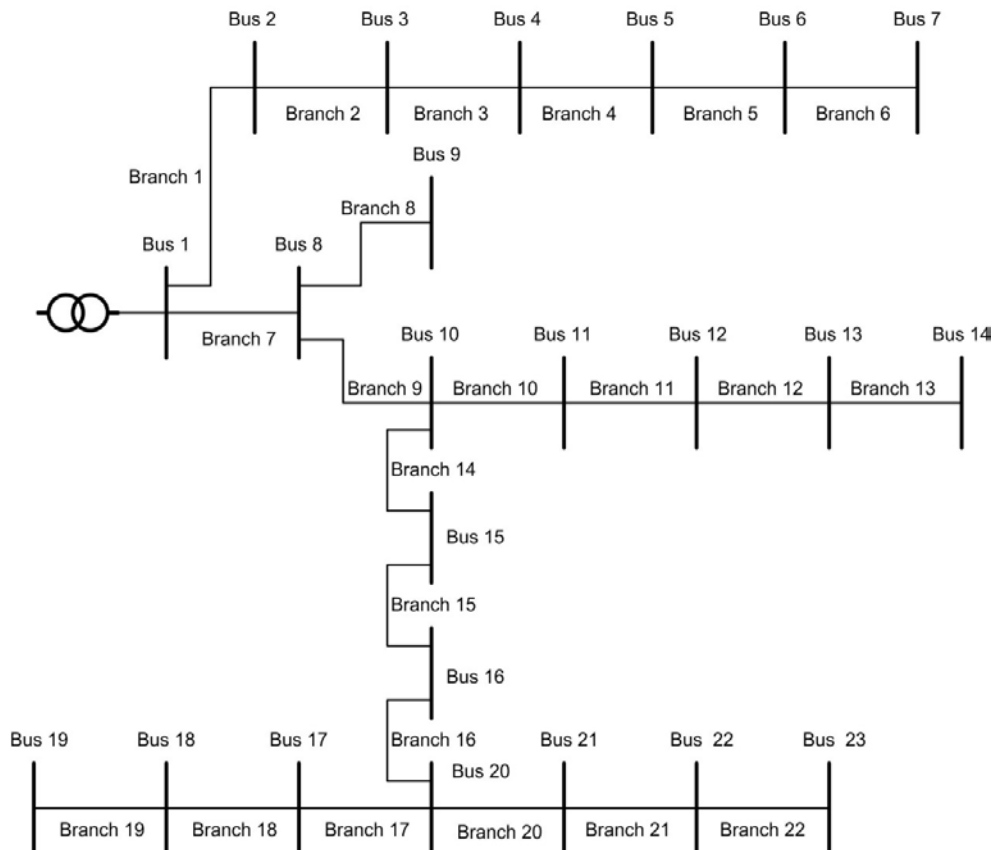

Figure 1 – Perth Solar City high penetration feeder one line diagram.

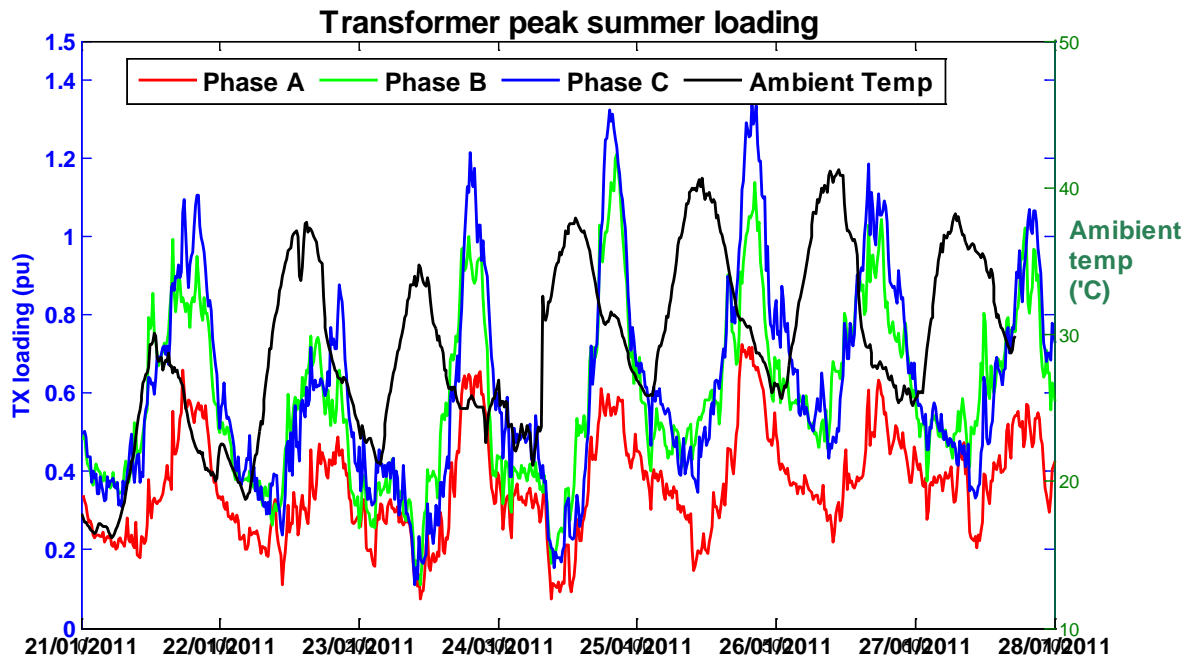

Figure 2 – Distribution transformer peak summer loading, January 21–27, 2012

Table 1 – The NPV of the distribution transformer for each year during planning period (5 years).

Planning year#	NPV_y^{Trans} (k AU\$)
1	2,617
2	2,493
3	2,374
4	2,261
5	2,153

Table 2– Loss of life (LOL) of the considered distribution transformer and the corresponding equivalent cost in *Scenario-1* at all years of planning

Planning year#	Trans. loading (pu)	LOL in Scenario 1 (days)	The equivalent NPV of LOL (AU\$)
1	1.0	20	143
2	1.1	45	307
3	1.2	184	1,197
4	1.3	855	5,296
5	1.4	4,486	26,465
Total		5,590	33,409

Table 3– LOL of the considered distribution transformer and the corresponding equivalent cost in *Scenario-2* at all years of planning

Planning year#	Trans. loading (pu)	LOL in Scenario 2 (days)	The equivalent NPV of LOL (AU\$)
1	1.0	11	79
2	1.1	22	150
3	1.2	85	553
4	1.3	375	2,323
5	1.4	1868	11,020
Total		2,361	14,125

Table 4– LOL of the considered distribution transformer and the corresponding equivalent cost in *Scenario-3* at all years of planning

Planning year#	Trans. loading (pu)	LOL in Scenario 3 (days)	The equivalent NPV of LOL (AU\$)
1	1.0	11	79
2	1.0	11	75
3	1.1	22	143
4	1.2	85	527
5	1.3	375	2,212
Total		504	3,036

Table 3 shows the LOL of the transformer and the equivalent loss of NPV in Scenario-2, with PV and without DR. As seen from this table, the peak loading of the transformer does not change as the injection from PV systems do not coincide with the peak load period in the residential feeder. However, energy production from PVs reduces the loading of the transformer in the off-peak periods, resulting in less HST of transformer oil during the peak period. Therefore, the LOL of the transformer in this scenario is much lower than the figure without PV. Also, it can be seen that the LOL and the total loss of NPV during 5 years of planning is 2,361 days and AU\$14,125, respectively, which are reduced by about 58% compared to Scenario-1. These results show the effectiveness of PV integration for managing the lifetime of equipment such as transformers.

The evaluation of transformer LOL and the equivalent loss of NPV for Scenario-3, with PV and DR, is reported in Table 4. It is assumed that the first year of planning is for the preparation of volunteer contribution of the residential customer within a community-based DR program. It is assumed that 0.1 pu reduction in peak load, totally from all consumers, can be achieved through the DR during year 2 to 5. As seen from Table 4, the LOL of the transformer is just about 10% of that in Scenario-1 and about 20% of that in Scenario-2. In addition, the loss of equivalent NPV decreases dramatically in this scenario. The NPV loss in Scenario-3 is about AU\$3k, which is much lower than the corresponding values in Scenario-2 and 3 with the NPV loss of AU\$33k and AU\$14k, as shown in Figure 3. This validates that the installation of PV and implementation of DR can improve the lifetime of the transformer significantly. In Scenario-3, the equivalent lifetime loss during planning period is about 1.4 years, which is much higher for Scenario-2 and 3 with the values of 6.5 and 15.3 years, respectively, as seen from Figure 4.

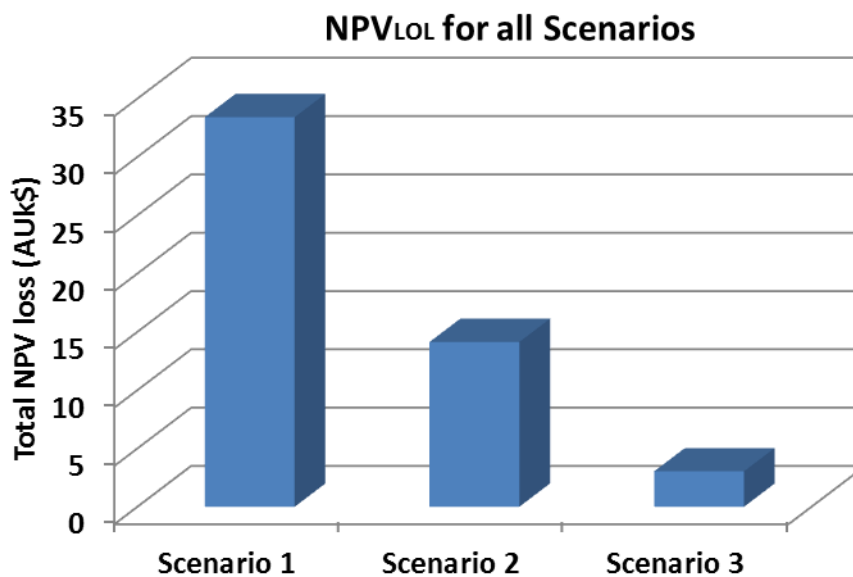

Figure 3 – NPV_{LOL} , total NPV loss due to LOL, for different Scenarios over planning period.

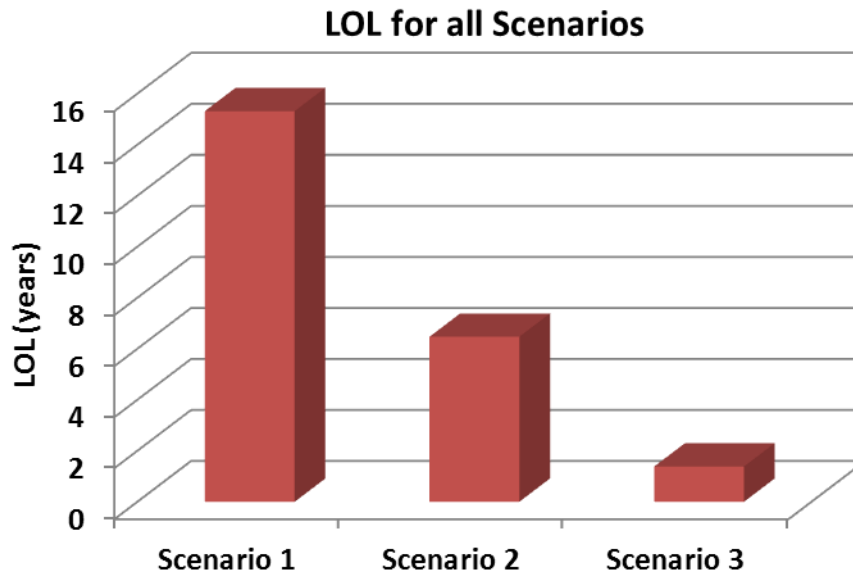

Figure 4 – LOL for different Scenarios over 5-year planning period.

4. Conclusions

The long-term evaluation of the LOL of distribution transformers due to load unbalance, PV installation, and DR integration is presented in this paper. In addition, the equivalent loss of NPV of transformers is formulated and investigated. Different scenarios are discussed to show the individual effect of PV and DR on the useful lifetime of the transformer. The analysis results indicate that PV integration and DR implementation can significantly extend the lifetime of distribution transformers. As an example, the inclusion of PV and DR in the feeder of the considered study case reduce the LOL and the associated value by 90%.

5. References

- (2011). Perth Solar City Project. Perth, Western Australia Government.
- (2012). "IEEE Guide for Loading Mineral-Oil-Immersed Transformers and Step-Voltage Regulators." IEEE Std C57.91-2011 (Revision of IEEE Std C57.91-1995): 1-123.
- Abeygunawardana, A., A. Arefi and G. Ledwich (2014). An efficient forward-backward algorithm to MSDEPP including batteries and voltage control devices. 2014 IEEE PES General Meeting | Conference & Exposition.
- Alam, M. J. E., K. M. Muttaqi and D. Sutanto (2014). "An Approach for Online Assessment of Rooftop Solar PV Impacts on Low-Voltage Distribution Networks." Sustainable Energy, IEEE Transactions on **5**(2): 663-672.
- Arefi, A., A. Abeygunawardana and G. Ledwich "A New Risk-managed Planning of Electric Distribution Network Incorporating Customer Engagement and Temporary Solutions."
- Awadallah, M. A., T. Xu, B. Venkatesh and B. N. Singh (2015). "On the Effects of Solar Panels on Distribution Transformers." Power Delivery, IEEE Transactions on **PP**(99): 1-1.
- Baran, M. E., H. Hooshyar, Z. Shen and A. Huang (2012). "Accommodating High PV Penetration on Distribution Feeders." IEEE Transactions on Smart Grid **3**(2): 1039-1046.

- Crine, J. P. (2005). "On the interpretation of some electrical aging and relaxation phenomena in solid dielectrics." *IEEE Transactions on Dielectrics and Electrical Insulation* **12**(6): 1089-1107.
- Environment, M. f. t. and M. f. I. a. Science (2015). Certainty and growth for renewable energy.
- Hayat, M. A., F. Shahnia and A. Arefi (2016). Comparison of the electricity tariffs and bills across the zones of Australian power distribution companies. 2016 Australasian Universities Power Engineering Conference (AUPEC).
- IEC (2005). Loading guide for oil-immersed power transformers.
- Moses, P. S. and M. A. S. Masoum (2012). "Three-Phase Asymmetric Transformer Aging Considering Voltage-Current Harmonic Interactions, Unbalanced Nonlinear Loading, Magnetic Couplings, and Hysteresis." *IEEE Transactions on Energy Conversion* **27**(2): 318-327.
- Navarro-Espinosa, A. and L. F. Ochoa (2015). "Probabilistic Impact Assessment of Low Carbon Technologies in LV Distribution Systems." *Power Systems, IEEE Transactions on PP*(99): 1-12.
- Pezeshki, H., P. J. Wolfs and G. Ledwich (2014). "Impact of High PV Penetration on Distribution Transformer Insulation Life." *IEEE Transactions on Power Delivery* **29**(3): 1212-1220.
- REN21 Steering Committee Renewables 2013, Global Status Report. Renewable Energy Policy Network for the 21st Century, Paris.
- Shahnia, F., R. P. S. Chandrasena, A. Ghosh and S. Rajakaruna (2014). "Application of DSTATCOM for surplus power circulation in MV and LV distribution networks with single-phase distributed energy resources." *Electric Power Systems Research* **117**: 104-114.
- Shahnia, F., A. Ghosh, G. Ledwich and F. Zare (2012). An approach for current balancing in distribution networks with rooftop PVs. 2012 IEEE Power and Energy Society General Meeting.
- Sharafi, D. (2010). Life Extension of a Group of Western Power Transformers. 2010 Asia-Pacific Power and Energy Engineering Conference.
- Simoni, L. (1999). "A general phenomenological life model for insulating materials under combined stresses." *IEEE Transactions on Dielectrics and Electrical Insulation* **6**(2): 250-258.
- Swift, G., T. S. Molinski and W. Lehn (2001). "A fundamental approach to transformer thermal modeling. I. Theory and equivalent circuit." *IEEE Transactions on Power Delivery* **16**(2): 171-175.
- Zhang, X. and E. Gockenbach (2008). "Asset-Management of Transformers Based on Condition Monitoring and Standard Diagnosis [Feature Article]." *IEEE Electrical Insulation Magazine* **24**(4): 26-40.