

Magnetic Design of a New Flat Magnetostrictive Actuators

S.Cinquemani^{1*}, H.Giberti²

¹Politecnico di Milano, Dipartimento di Meccanica, via La Masa 1, 20156, Milano, Italy.
²Università degli Studi di Pavia, Dipartimento di Ingegneria Industriale e dell'Informazione,
via Ferrata 5, 27100, Pavia, Italy.

*Corresponding author:

Abstract

Giant magnetostrictive actuators (GMA) have been used over years to actively suppress vibration in structures. Despite this technology has been deeply investigated, magnetostrictive materials have been used only to develop inertial actuators, while patches actuators have never been realized. They consist on a layer of magnetostrictive material, which has to be bounded to the surface of the vibrating structure, and on a coil surrounding the layer itself. Although the design is simple, the presence of the winding severely limits the practical use of such devices. As a matter of fact, the scientific literature does not report practical application of flat actuators, despite their use is suggested in theoretical researches.

The paper deals with the design of a new flat actuator, based on magnetostrictive material, overcoming traditional limitations and allowing their use in several practical applications. Numerical analysis confirm the good performance of this new device and recommend the transition to prototyping.

Keywords: Magnetostrictive Actuator, Terfenol-D, Magnetostriction, Magnetic design

INTRODUCTION

Magnetostrictive actuators can be profitably used to reduce vibration in structures [1] as they can exert high forces in a wide range of frequency. However, this technology has been exploited only to develop inertial actuators, while patches actuators have not been ever used in practice. Magnetostrictive actuators have usually a traditional configuration. According to Figure 1, the active element is a giant magnetostrictive rod which is surrounded by a coil and it is subjected to a bias magnetic field generated by permanent magnets placed at the ends of the bar. When the supplied current flows in the coil, a variation of the electric field that passes through the magnetostrictive material produces a change in the magnetic field opposing this variation.

This leads to the subsequent alignment of the magnetic domains of the material and thus to the lengthening/shortening of the magnetostrictive rod and to the generation of a high force [3, 4, 6].

A pre-stress mechanism (generally a screw) compresses the magnetostrictive rod pushing it on an elastic element. The requirement of the active material to be mechanically compressed during operation is twofold. The tensile strength of the material is limited ($\approx 28\text{MPa}$ [19]) and the efficiency and coupling factors are considerably higher under compression [5]. This configuration can be profitably used to build inertial actuators [6–8] but it cannot be used to produce flat magnetostrictive patches.

Patch actuators require a different layout, compared to inertial ones, because they interact with the structure in a different way. The inertial actuators are simply supported on the structure and the force they exert acts perpendicularly to the structure. This condition allows to design the actuator in a simple way. On the contrary, patch actuators require that the entire surface of the magnetostrictive shell is rigidly fastened to the structure as the exerted force acts parallel to the surface, thus generating a bending moment on the structure. The main advantage of this configuration is to have small actuators that, in some cases, may even be integrated within the structure (as it is commonly done for piezoelectric patches). This constraint does not allow the generation of a magnetic field inside the material through a winding, unless the coil surrounds the entire structure.

The scientific literature reports only theoretical uses of such actuators [9–14] but, in practice, it does not seem they were ever used. According to the author's knowledge, there are no results of practical interest, except for the solutions shown in Figure 2 and Figure 3 in which the winding, used to generate the magnetic field, surrounds the entire structure on which the magnetostrictive patch is bound [17, 18]. Naturally, such a constructive complexity makes impracticable the use of magnetostrictive patch actuators in most cases.

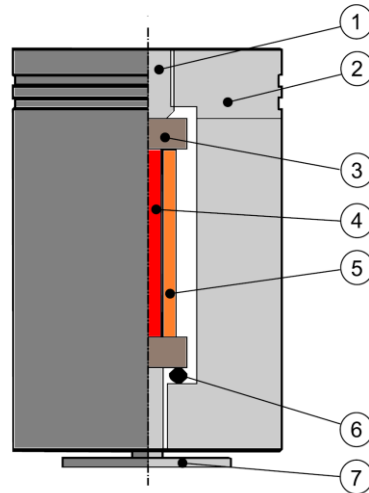

Figure 1. Section of a linear inertial magnetostrictive actuator: (1)-Prestressing screw (2)-Inertial mass, (3)-Permanent Magnets, (4)-Magnetostrictive rod, (5)-Coil, (6)-Spring, (7)-End Effector.

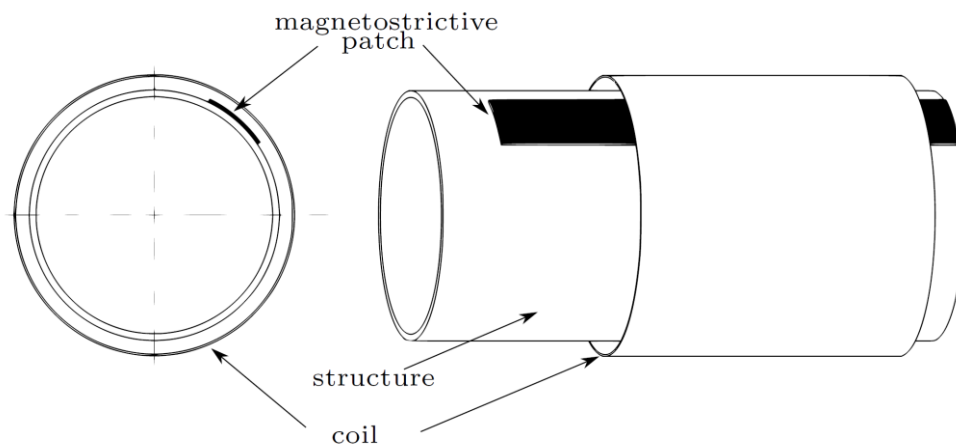

Figure 2. A solution of traditional magnetostrictive patch devices [17].

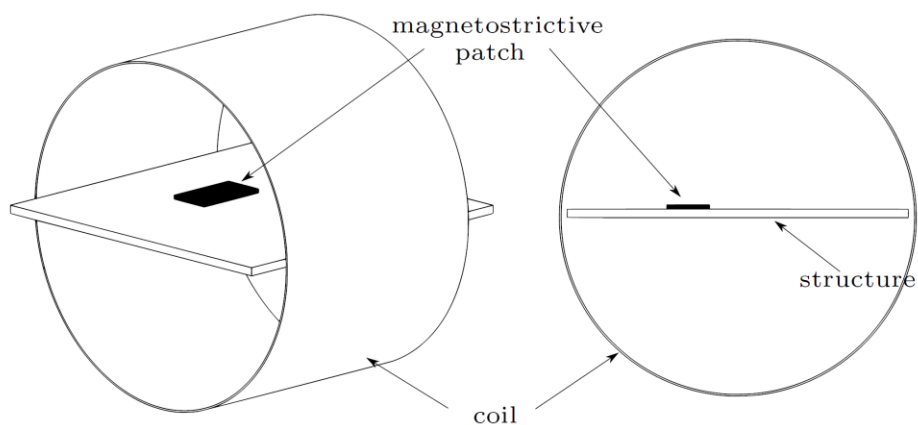

Figure 3. A solution of traditional magnetostrictive patch devices [18].

The paper introduces a new layout of magnetostrictive patch actuators to overcome the limits of traditional devices. The basic idea is to generate the variable magnetic field no longer in the close proximity of the magnetostrictive material, but in a different place, thus allowing a better coupling with the structure and reducing the out-of-plane dimensions of the device. The magnetic field is then conveyed through a suitable ferromagnetic structure to the magnetostrictive material.

The paper is structured as follows: Section 2 describes the layout of both traditional and innovative devices based on magnetostrictive patch. To assess the effectiveness of the new solution, an analytical model is provided for the calculation of the magnetic flux inside the magnetostrictive material. Section 3 collects main results of numerical simulation to evaluate the performance of the new layout compared to the traditional one. Conclusions are drawn in section 4.

ACTUATOR LAYOUT

The main requirements of the new layout, to overcome limits of traditional devices, must be:

- The size of the actuator must be small and must lie mainly in the plane of the patch;
- The patch must be able to be bound to the structure without the need to realize the winding around it;

- The magnetic flux must be strong enough to stimulate the magnetostrictive effect and has to be variable.

These conditions have led to the idea of generating the variable magnetic field no more around the magnetostrictive material, but in a different place and then to convey it through a magnetic circuit.

Figure 4a shows the traditional configuration of the magnetostrictive actuators. As can be easily noted, the patch cannot be bounded to the structure because of the winding. On the contrary, Figure 4b shows a sketch of the new layout. The shell of magnetostrictive material is placed inside a rectangular ring of ferromagnetic material and can be easily bound to the structure. A winding made on two sides of the ring allows to generate a variable magnetic field that is conveyed within the magnetostrictive material from the ring itself.

To preliminary evaluate the magnetic flux and the flux density inside the magnetostrictive patch, a simple magnetic circuit model can be used for a rough estimation. Figure 5a shows the magnetic circuit of the traditional layout, while Figure 5b the one corresponding to the new layout.

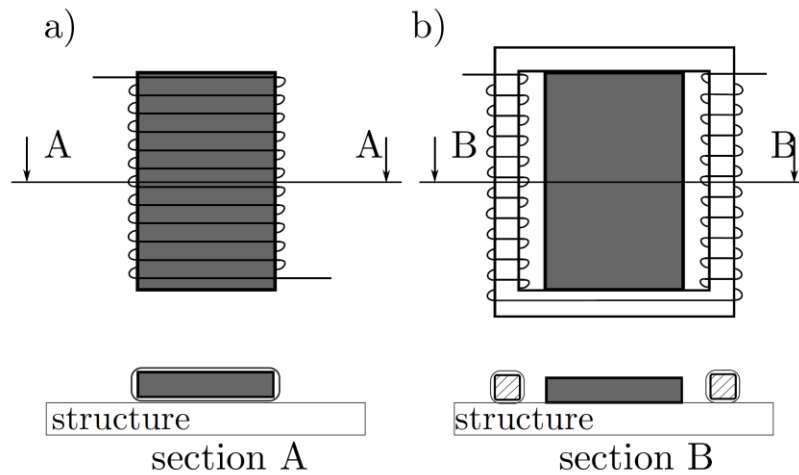

Figure 4. Layouts of traditional configuration (a) and innovative solution (b).

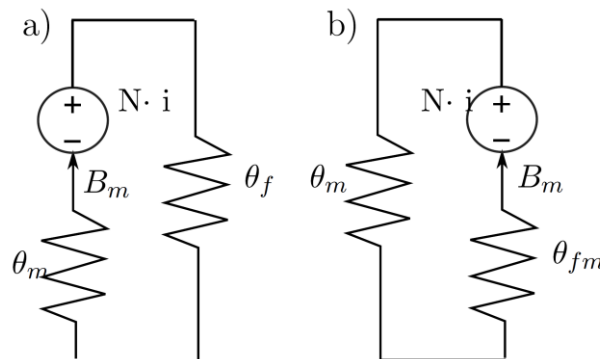

Figure 5. Equivalent magnetic circuits for traditional (a) and innovative (b) layouts.

The flux density inside the magnetostrictive material can be estimated in the two cases. The Wheeler formula for coils in air allows to obtain the inductance as:

$$L(H) = k \cdot 0.987 \cdot 10^{-7} \cdot N^2 \frac{d^2}{l} \quad (1)$$

where N is the number of turns of the winding, d is the mean diameter of the coil, l its length and k is a coefficient that depends on the geometry of the magnetic field.

The equivalent permeance is

$$\Lambda_{tot,air} = k \cdot 0.987 \cdot 10^{-7} \cdot \frac{d^2}{l} \quad (2)$$

and then, the magnetic reluctance is

$$\mathcal{G}_{tot,air} = \frac{1}{\Lambda_{tot,air}} = \frac{1}{k \cdot 0.987 \cdot 10^{-7} \cdot \frac{d^2}{l}} = 1.266 \cdot 10^7 \frac{l}{d^2} \quad (3)$$

where k has been supposed to be equal to 0.8 considering the shape of the magnetic field [21].

The permeance and the reluctance of the magnetic field inside a coil in air ($\mu_0 = 4 \cdot 10^{-7}$) are respectively

$$\Lambda_{tot,air} = \mu_0 \cdot \frac{\pi}{4} \cdot \frac{d^2}{l} \quad (4)$$

$$\mathcal{G}_{tot,air} = \frac{1}{\Lambda_{tot,air}} = 0.1013 \cdot 10^7 \cdot \frac{l}{d^2}$$

Thus the reluctance of the magnetic field outside the coil is

$$\mathcal{G}_{tot,air} = \mathcal{G}_{tot,air} - \mathcal{G}_{air,in} = (1.266 - 0.1013) \cdot 10^7 \cdot \frac{l}{d^2} = 1.165 \cdot 10^7 \cdot \frac{l}{d^2} \quad (5)$$

Considering the new layout, if inside the coil there was a magnetostrictive material ($\mu = 12\mu_0$ [19]) then the reluctance would be:

$$\mathcal{G}_{mag} = \frac{1}{12 \cdot \pi^2 \cdot 10^{-7} \cdot \frac{d^2}{l}} = 1.215 \cdot 10^7 \frac{l}{d^2} \quad (6)$$

and then, for the traditional layout, the total reluctance would be:

$$\mathcal{G}_{tot,a} = \mathcal{G}_{tot,air} + \mathcal{G}_{mag} = 2.380 \cdot 10^7 \cdot \frac{l}{d^2} \quad (7)$$

When the closure of the flow takes place via a ferromagnetic material (or ferrite), whose permeability is much greater, such as to render negligible its reluctance ($\theta_{fm} \approx 0$) with respect to the one of the magnetostrictive material, the total reluctance $\theta_{tot,b}$ could be considered equal to θ_{mag} .

$$\mathcal{G}_{tot,b} = \mathcal{G}_{mag} = 1.215 \cdot 10^7 \cdot \frac{l}{d^2} \quad (8)$$

On equal magnetomotive force, the ratio between the magnetic flux for traditional and innovative layouts is:

$$\frac{\mathcal{G}_{tot,b}}{\mathcal{G}_{tot,a}} = 2.04 \quad (9)$$

thus demonstrating that the new configuration is better also from the point of view of the generation of the magnetic field density inside the magnetostrictive material. The improved efficiency is related to a better way to exploit the magnetic field closure: in traditional layouts most of the magnetic field is in open air (high reluctance), while the new layout allows to better close the magnetic loop through ferromagnetic materials (very low reluctance), thus increasing the efficiency of the device.

NUMERICAL ANALYSIS

A more accurate estimation can be derived from a finite element analysis of the device. The two layouts are compared considering the parameters collected in Tab.1

Table 1. Main parameters.

Patch dimensions [mm]	40 × 20 × 1
Ring dimensions [mm] (short side)	33, 23
Ring dimensions [mm] (long side)	51, 41
Ring thickness [mm]	2
wire diameter [mm]	0.5
no. of turns	40
current [A]	5

First the traditional layout has been analyzed. Figures 6, 7 show the magnetostrictive patch surrounded by the winding and the corresponding magnetic field when a current of 5 A flows.

The maximum magnetic field density inside the magnetostrictive material is equal to $B_{max} = 4.1 \cdot 10^{-2}$ T. The layout of the new actuator is depicted in Figure 8. The magnetostrictive patch is in the middle of a rectangular ring whose long sides are surrounded by two windings obtained as shown in Figure 5

Figures 9 and 10 depict the magnetic field density inside the material along two orthogonal directions. It has to be noted that the magnetic field id quite constant along the materials allowing to have the best performance in terms of magnetostrictive effect. For this configuration, the maximum magnetic field density inside the magnetostrictive material is equal to $B_{max} = 1.12 \cdot 10^{-1}$ T.

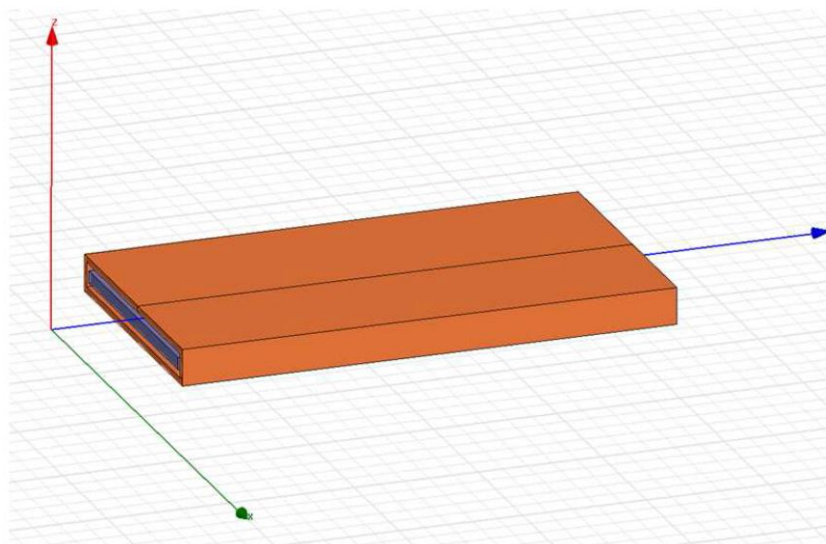

Figure 6. Magnetostrictive patch actuator: traditional layout.

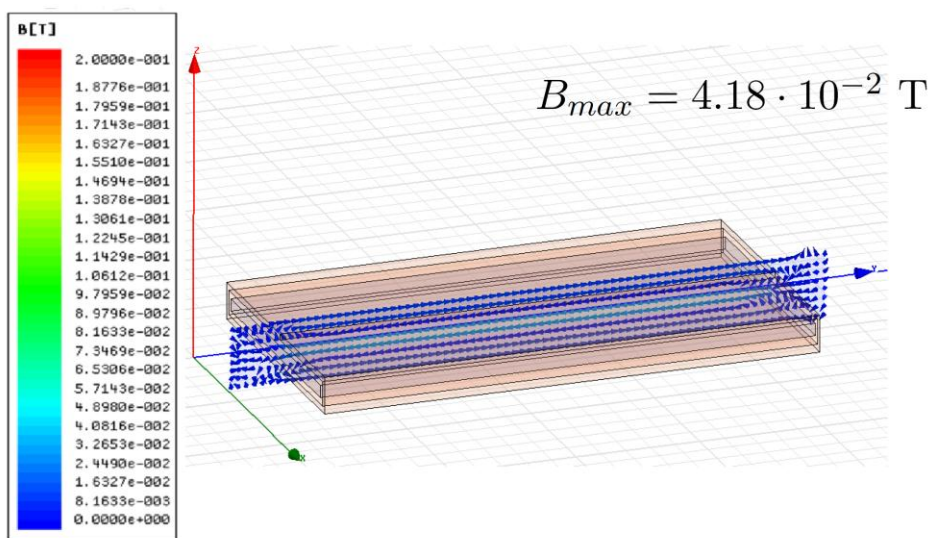

Figure 7. Magnetic field density inside the material.

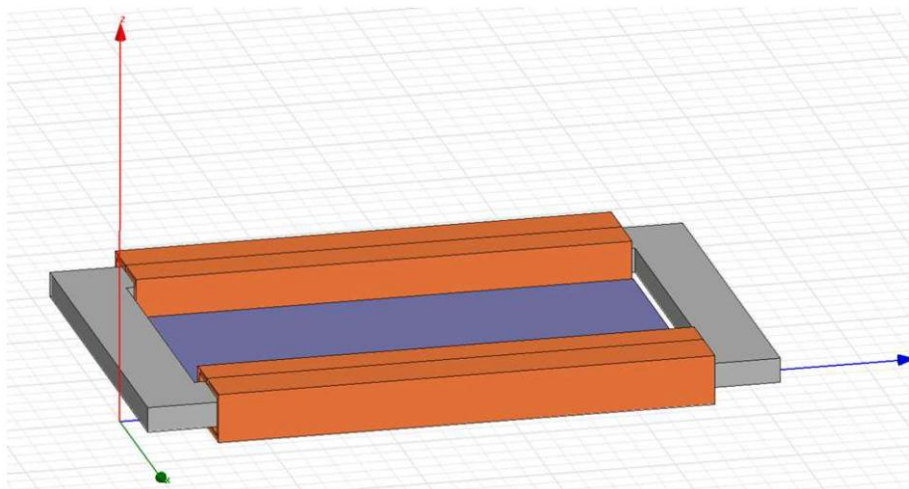

Figure 8. Magnetostrictive patch actuator: innovative layout.

$$B_{max} = 1.12 \cdot 10^{-1} \text{ T}$$

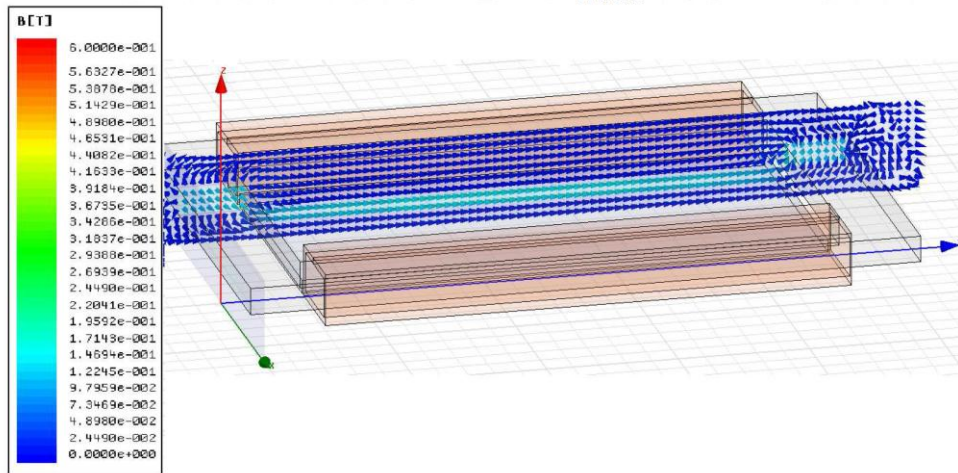

Figure 9. Magnetic field density inside the material: longitudinal section.

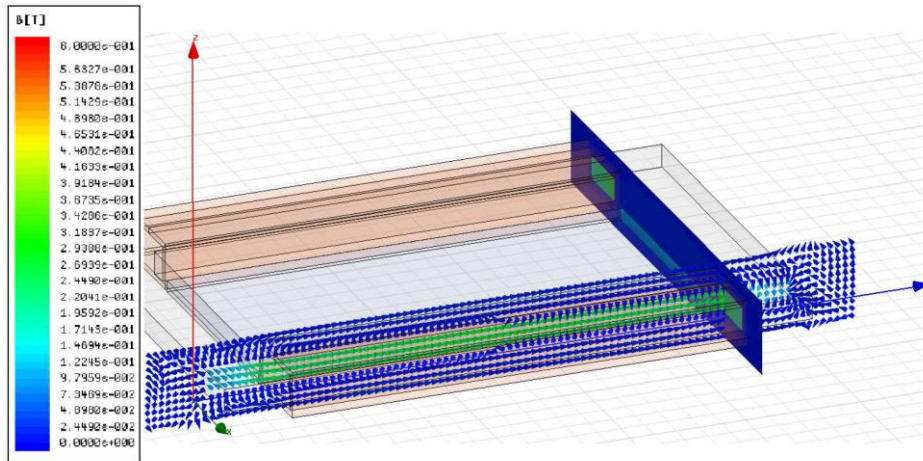

Figure 10. Magnetic field density inside the material: cross section.

According to preliminary analysis, the innovative layout developed for magnetostrictive patch devices allows to overcome all the limits of traditional devices. The new solution allows to generate a magnetic field far from the magnetostrictive material and to lead it to the patch ensuring higher flux density.

CONCLUSIONS

A new layout for magnetostrictive patch actuators has been introduced. The most significant innovation consists in generating the magnetic field, necessary to control the magnetostrictive effect, no longer in close proximity of the material itself, but in a different area, thus allowing a better coupling between the patch and the structure to force. Through an appropriate magnetic circuit, the field is then conveyed into the magnetostrictive material.

The device has been designed and simulated through FEA. Results confirm that the new configuration can easily overcome all the limits of traditional devices.

REFERENCES

- [1] Cinquemani, S., Resta, F., “A mechanical approach to the design of independent modal space control for vibration suppression” Journal of Vibration and Acoustics, Transactions of the ASME 135(5), 2013, 051002.
- [2] Noh, M.D. and Park, Y.W. “Topology selection and design optimization for magnetostrictive inertial actuators” Journal of Vibration and Acoustics, Transactions of the ASME 111, 07E715, 2012.

- [3] Engdahl G., "Handbook of Giant Magnetostrictive Materials", Academic press, (2000).
- [4] Pons J.L., "Emerging Actuator Technologies: A Micromechatronic Approach", John Wiley and Sons Ltd, (2005).
- [5] Dapino M.J., Smith R.C., Faidley L.E., Flatau A.B., "A Coupled Structural-Magnetic Strain and Stress Model for Magnetostrictive Transducers", *Journal of Intelligent Material Systems and Structures*, 11, pp.135~151, (2000).
- [6] Braghin F., Cinquemani S., Resta F., A model of magnetostrictive actuators for active vibration control, *Sensors and Actuators A: Physical*, **165**, 2, pp.342~350, (2011)
- [7] Braghin F., Cinquemani S., Resta F., A low frequency magnetostrictive inertial actuator for vibration control, *Sensors and Actuators A:Physical*, 180, pp.67~74, (2012)
- [8] Braghin F., Castelli-Dezza F., Cinquemani S., Resta F., A full-range hybrid device for sound reproduction, *Smart Structures and Systems*, **11**, 6, pp.605~621, (2013)
- [9] Datta, S., Atulasimha, J., Mudivarthi, C., Flatau, A.B., Modeling of Magnetomechanical Actuators in Laminated Structures, *Journal of Intelligent Material Systems and Structures*, 20, pp.1121~1135, (2009)
- [10] Pradhan, S.C., Ng, T.Y., Lam, K.Y., and Reddy, J.N., Control of laminated composite plates using magnetostrictive layers, *Smart Materials and Structures*, 10, pp.657~667, (2001)
- [11] Pradhan, S.C., Vibration suppression of FGM shells using embedded magnetostrictive layers, *International Journal of Solids and Structures*, 42, pp.2465~2488, (2005)
- [12] Qian, W., Liu, G.R., Chun, L. and Lam, K.Y., Active vibration control of composite laminated cylindrical shells via surface-bonded magnetostrictive layers, *Smart Materials and Structures*, 12, pp.889~897, (2003)
- [13] Pradhan, S.C., and Reddy, J.N., Vibration control of composite shells using embedded actuating layers, *Smart Materials and Structures*, 13, pp.1245~1257, (2004)
- [14] Chai, W. K., Arnold, S.M., Lee, H.J. and Tzou, H. S., Magnetostrictive Microactuators and Modal Sensitivities of Thin Magnetoelastic Shells *Journal of Pressure Vessel Technology*, **130**, 1, 011206, (2008)
- [15] Datta, S., Atulasimha, J., Mudivarthi, C., Flatau, A.B., Modeling of Magnetomechanical Sensors in Laminated Structures, *Smart Materials and Structures*, 17, 025010, (2008)
- [16] Guerrero V.H. and Wetherhold, R.C., Magnetostrictive bending of cantilever beams and plates, *Journal of Applied Physics*, **94**, 10, 6659, (2003)
- [17] Kumar J.S., Ganesan N., Swarnamani S., Padmanabhan C., "Active Control of Cylindrical Shell with Magnetostrictive Layer", *Journal of Sound and Vibration*, 262, pp.577~589, (2003).
- [18] Kumar J.S., Ganesan N., Swarnamani S., Padmanabhan C., "Active control of simply supported plates with a magnetostrictive layer", *Smart Materials and Structures*, 13, pp.487~492, (2004).
- [19] Clark A.E., Savage H.T., Spano M.L., "Effect of Stress on Magnetostriction and Magnetization of Single Crystal of Tb₂₇Dy₇₃Fe₂", *IEEE Transactions on magnetics*, **20**, 5, pp.1443~1445, (1984).
- [20] Kellogg R.A., Flatau A., Clark A.E., Fogle M.W., Lograsso T., "Quasi-Static Transduction Characterization of Galfenol", *Proc. of ASME International Mechanical Engineering Congress*, Washington, D.C., (2003).
- [21] Thompson, M. , "Inductance Calculation Techniques – Part II: Approximations and Handbook Methods", *Power Control and Intelligent Motion*, 1999