

Assessing the Remote Engineering Lab VISIR at Al-Quds University in Palestine

<http://dx.doi.org/10.3991/ijoe.v11i1.4219>

Salaheddin Odeh¹, Mahasen Anabtawi¹, Gustavo Ribeiro Alves², Ingvar Gustavsson³, Labib Arafeh¹

¹Al-Quds University, Abu Dies, Jerusalem, Palestine.

²Polytechnic of Porto, Porto, Portugal

³Blekinge Institute of Technology, Blekinge, Sweden.

Abstract—Engineering labs play a vital role in engineering education, make science come alive, and supply students with better understanding of theories. As a result, they contribute to the improvement of their knowledge and skills. Remote labs not enable sharing of teaching resources such as devices, equipment and instrumentations between universities, but also relax time and space constraints; yet they are considered as a complementary asset to the traditional hands-on labs. This paper is concerned with a two-stage assessment of the engineering remote lab VISIR. In the first stage, the assessment investigated if the students accept to use VISIR in their future lab courses at the Faculty of Engineering at Al-Quds University in Palestine. In the second stage, a deeper analysis will be performed to compare VISIR to hands-on and simulators based on the evaluation criteria: performance, students' retention rate and satisfaction survey.

Index Terms—VISIR; remote labs; survey instruments; comparative evaluation; design criteria.

I. INTRODUCTION

Laboratory experiments represent the heart of engineering learning. They enable the transformation of bare knowledge into tangible technologies devoted to the welfare of human kind. There are three categories of labs: hands-on, simulators and remote labs. Hands-on labs are the most popular; they require the physical existence of both students and instruments at the same place simultaneously. They give the students the clearest tangible experiments ever. Their major disadvantage is their requirement of money, space and infrastructure [1]. Simulators are simply imitators, they depend on mathematical models which weakens the students' reference to reality; furthermore, they lack high precision [2]. Remote labs are real labs, just like hands-on labs, that can be shared through the Internet with a large number of students; thus, they relax cost, time and space constraints, which represent their unique powerful character over the previous categories.

In this paper, VISIR (Virtual Instrument System in Reality), which is a remote engineering lab, is applied and assessed at Al-Quds University, in the Faculty of Engineering [3]. The assessment was performed in two successive stages:

The first stage: The students performed the RC filter experiment using hands-on labs and the VISIR remote lab. Then they answered a questionnaire designed to measure: usefulness, satisfaction, usability and sense of immersion. In the second stage, students will perform the common

emitter amplifier circuit for measuring the lower and upper cut-off frequencies using the three categories of labs. Then they will answer a questionnaire that measures the weaknesses and strengths of VISIR over hands-on and simulator labs. The questionnaire is designed to measure: students' retention rate, satisfaction and performance. Data will be analyzed using SPSS.

II. VISIR REMOTE LAB.

The VISIR Open Lab Platform designed at the Department of Electrical Engineering (AET), the Blekinge Institute of Technology (BTH), Sweden, is an architecture for opening existing types of hands-on labs for remote access with preserved context in order to in the first place supplement and increase the accessibility and the capacity of them. A unique interface gives the student a feeling of being in the hands-on lab [4]. Some types of labs are easier to open for remote access than others are. So far, the current VISIR platform (4.1) supports labs for electrical experiments and for mechanical vibration experiments.

VISIR platform has been described in many works [5][6][7]; but here we only want to remark the most important parts of it:

- Web interface: it makes possible that the user can perform the same actions as she/he was in the traditional lab. Its powerful interface developed in Adobe Flash (and recently updated to HTML5) represents realistic front panels of the equipment used by the students to test the circuits developed in the virtual breadboard.
- Measurement server: it acts as a virtual instructor that controls the commands passing from the Web interface to the equipment server to prevent hazard circuit designs and protect the instruments. It is programmed by 'max list' files, which contains the maximum component values and instruments adjustments for each experiment and describes the allowed circuits in the platform.
- Equipment server: the PXI platform connected to the relay switching matrix, and both are controlled by this server written in LabVIEW. It receives the commands from the measurement server over TCP/IP to be executed on the real instruments. A 'component list' file is inserted to the equipment server to define the components installed on the matrix.
- The switching matrix: it is the matrix especially developed for this remote lab that performs the connections between the components and instruments that the user has carried out in the Web interface.

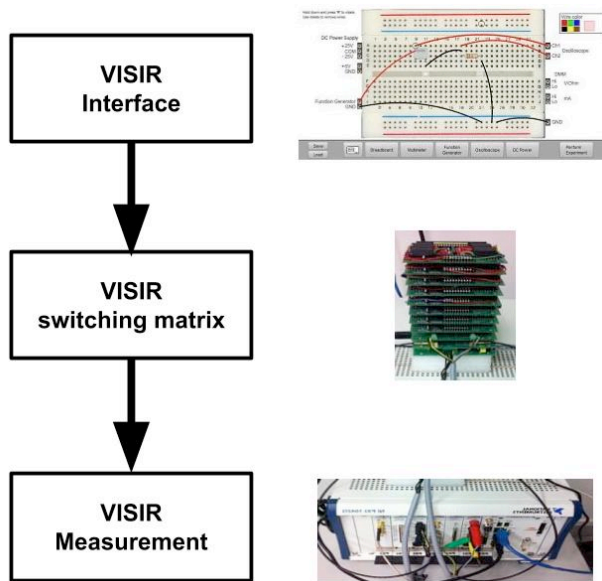

Figure 1. Practical session work flow using VISIR lab.

Fig. 1 represents graphically the work flow at a VISIR practical session: the Web interface allows the student to create the circuit in a virtual way through a Web browser while the measurement and equipment server both are in charge of making this circuit real on the switching matrix and to provide the user with the measurements obtained from the previously created circuit.

III. APPLYING AND ASSESSMENT VISIR AT AL-QUDS UNIVERSITY.

A group of 71 students (34 females and 37 males) performed the RC filter experiment using hands-on labs, then the remote VISIR lab. The instructor added the students to a virtual course entitled “Collaboration-Al-Quds” which was prepared by the VISIR’s administrator. As mentioned previously, the assessment was performed in 2 stages; where in the first stage, a usability testing was performed to find out whether students will accept to use VISIR in their future laboratory courses, in the second stage, a comparative evaluation will be performed using a survey instrument.

A. Stage One: Usability Testing

A usability testing based on survey instruments: At this stage, a survey based on Tawfik et al [3] survey was used to evaluate the VISIR lab. A total of 71 engineering students (34 females and 37 males) enrolled in the course Instrumentation and Control Systems performed the RC filter experiment. They performed it using traditional labs, then using the VISIR remote lab. Students used the virtual breadboard to connect the remote physical components and equipment according to the desired RC circuit. Fig. 2 shows the virtually connected RC circuit. In a further step, they answered the survey to evaluate the VISIR lab. Table I shows the survey questions that were categorized chronically into two categories: Before and after using VISIR; and to four evaluation categories according to the following evaluation criteria:

- Q1-Q3: Measures the satisfaction of students with the traditional labs.
- Q4-Q9: Measures the usability of VISIR.

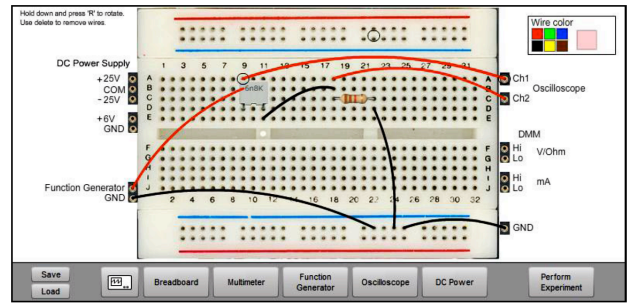

Figure 2. The virtually connected RC filter circuit on the virtual breadboard of the VISIR remote lab.

TABLE I.
 SURVEY QUESTIONS OF THE EVALUATION

Survey time	Evaluation Criterion	Survey question
Before	Satisfaction	I feel that results achieved in traditional labs are in accordance with the intended learning outputs of the lab experiments
		I face a lot of troubles in the traditional lab
		After carrying out an experiment in the lab, I wish I have more time to exercise more on it
After	Usability	Using VISIR is easy and convenient
		I don't need the assistance of the experiment tutor in most of the activities
		While using VISIR, I was motivated to continue carrying out the experiment
		I don't have problems with the assigned time
		Moving between the breadboard page and other equipment and instrumentations pages is without hindrance
		As it is case with VISIR, placing the breadboard on a separate page and the other equipment on another simplified my interaction with system
After	Sense of reality/immersion	I felt that VISIR is real and not virtual
		The equipment and instrumentations in VISIR are identical to their real equivalence.
		Although I am being far from the VISIR, I have felt myself to be in control of it
		I would like to have a Webcam (clock, a device, a screen, etc.) at the side of the lab server, in order to improve my interaction between the users and the remote lab
After	Usefulness and satisfaction	I think using VISIR will strengthen both my skills and theoretical background
		I would like to use VISIR in other subjects.
		I think that remote labs such as VISIR serve as a complement to hands-on
		I think if two or more students located at different places have the opportunity to work together on an experiment, this will stimulate the collaborative working between students

- Q10-Q13: Measures the sense of reality/immersion of students using VISIR.
- Q14-Q17: Measures the usefulness and satisfaction of students using VISIR.

IV. RESULTS

Fig. 3 shows the results of the survey questionnaire after being statistically analyzed. From this figure, we notice the following:

- Students' satisfaction of traditional labs is low. Question 1 had the lowest mean value of 1.5 which says that 'I feel that results achieved in traditional labs are in accordance with the intended learning outputs of the lab experiments.
- Most of survey results assessing VISIR remote lab had higher means compared to traditional labs.
- Questions 4,6, 8 had greater mean value of 4.
- Question 8 had the greatest mean value of 4.4, which states that "moving between the breadboard page and other equipment and instrumentation pages is without hindrance".
- Question 13 had the greatest variance value which states that 'I would like to have a webcam at the side of the lab server, in order to improve interaction between the users and the remote lab.

Fig. 4 shows a graphical comparison between the four categories of the survey questionnaire; namely, satisfaction, usability, sense of reality/immersion, usefulness and satisfaction. Moreover, it shows that the usability category had the highest mean value over all other categories.

A. Stage two: Comparative assessment

In the second stage, a comparative assessment with a group of more than 50 engineering students belonging to the two departments electronics and computer engineering will be carried out. A more complicated electronic circuit, particularly, a common emitter amplifier circuit for measuring either the lower or the upper cutoff frequencies is selected because of the fact that, in this stage, the goal of this assessment is to find out strengths and weaknesses of remote labs represented here by VISIR in comparison with its traditional and simulation equivalences.

The independent variables are represented in this assessment by the three lab approaches; namely, traditional, remote and simulated which are assumed to affect the dependent variables. The dependent variables are represented by the evaluation criteria designed to measure the fundamental course objectives of engineering labs which include: Student's retention rate, satisfaction, and student's performance. Those will be compared for the three independent variables: remote labs, traditional and the simulators.

These assessment criteria will be measured for three practical sessions with different students, conducting the same experiment using hands-on, simulation and the remote VISIR approaches. Accordingly, a comparative study will be performed to compare the retention rate, students' performance and their satisfactions. The three assessment criteria are:

Retention Rate: In engineering labs, students are essentially expected to work in groups, "practice by doing" and "teach others". The retention rates that correspond to each teaching have been demonstrated by Singhal et al [8]. It is clear that the "Lecture" as a teaching method is the least effective one from the retention viewpoint. The "Practice by Doing" teaching method has a 75% retention rate; whereas, "Teach Others / Immediate use" has a 90% reten-

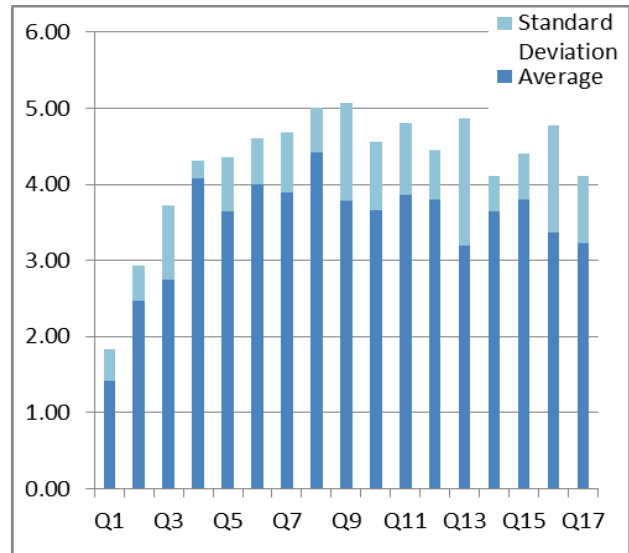

Figure 3. Survey results of the survey questions.

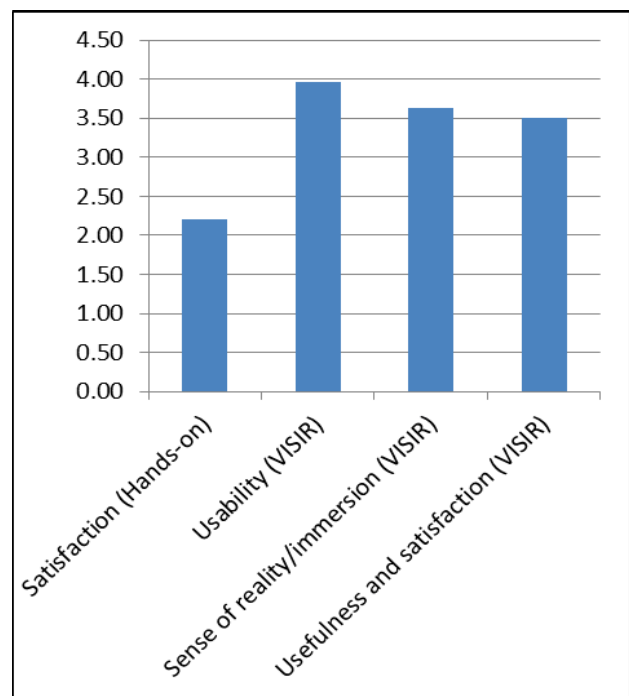

Figure 4. Evaluation results of the evaluation criteria.

tion rate. We believe as instructors that the "Practice by Doing" component will be completed by build and test phase of the teaching process; otherwise, the teaching method and the educational impact will be less effective. Furthermore, by allowing the students to work in groups, we provide them the experience to work in teams and practice the "Teach Others" element that has the highest retention rate.

Satisfaction Survey: A survey-like questionnaire will be developed to measure the students', instructors' and technicians' satisfactions for the three models of covering the experiment.

Student's Performance: For the student's performance, we have to assess the thirteen fundamental objectives of engineering instructional laboratories [9]. These essential objectives should be provided and accordingly used as a

measure to assess the students' competencies and performance with respect to the experiment they will conduct. These objectives can be categorized into three types. The first type deals with cognitive aspects such as Instrumentation, Models, Experiment, Data Analysis and Design. The second category involves the psychomotor that targets the ability to actually manipulate apparatus and the Sensory Awareness, Learn from Failure, Creativity, Psychomotor, Safety, Communication, Teamwork, Ethics in the Laboratory and Sensory Awareness. The last two-fold category includes cognitive and emotional behaviour and attitudes fields. These objectives include learn from failure, creativity, safety, communication, teamwork, and ethics in the laboratory [10].

V. CONCLUSION

The experiences of applying VISIR in the Engineering Faculty at Al-Quds University in Jerusalem in Palestine include a survey where 71 engineering students have answered a questionnaire comprising 17 closed-ended questions. The first stage of the evaluation accomplished by a survey instrument was concerned to measure the students' acceptance, satisfaction etc. before introducing of a technology at the engineering faculty; it shows that the students found VISIR useful and satisfies their experimentation needs. It was shown in the results that:

- Students' satisfaction of traditional labs was low, which can be explained by the fact that access to resources is restricted to normal working hours; consequently leading to increased number of students attending the lab to perform the experiments.
- The user interface of VISIR is user-oriented and adapted to the student's needs in the engineering labs, because most of the survey results about VISIR had higher mean values compared to the traditional lab's means.
- Distributing virtual components on several pages is the preferred version for the students. (Question 8 mean value 4)
- The user is supported correctly through VISIR, as there was no necessity for the instructor help. (Question 5 mean value 3.8)
- Students have different opinions about adding some modifications as webcam. A Student said it is necessary to have access to real devices so it could be possible to feel like doing real experiment which will lead to deeper engagement of task. (Question 13 highest deviation)
- It is recommended to open the remote labs 24 hours a day/7 days a week using Web browsers only.
- A major advantage of applying VISIR is to enhance academic cooperation between universities and to overcome time, cost and space limitations.

In the second stage of our evaluation study, a more in-depth comparative analysis will be carried out in order to have a classification of VISIR in the landscape of other kind of engineering laboratories such as traditional hands-on and simulations, for example, PSpice. This classification is in accordance with the fundamental course objectives of engineering instructional labs: student's retention rate and satisfaction survey, as well as their performance.

ACKNOWLEDGMENT

Many thanks go to the VISIR group at ISEP in Porto in Portugal for their acceptance for accessing and testing VISIR using their VISIR lab as well as for the preparation of the remote experiment. This study would not have been possible without their acceptance and allowance to access the remote lab.

REFERENCES

- [1] aJ. Ma, and J. Nickerson, "Hands-On, Simulated, and Remote Laboratories: A Comparative Literature Review," *ACM Computer Survey*, Vol.38, Issue 3, Article No.7, 2006.
- [2] Z. Nedic, J. Machotka, A. Nafalski, "Remote laboratories versus virtual and real laboratories," in: *Proc. of the 33rd ASEE/IEEE Frontiers in Education Conference*, pp. T3E-1-6. Boulder, Colorado, USA, November (2003).
- [3] M. Tawfik, E. Sancristobal, M. Sergio, R. Gil, G. Diaz, A. Colmenar, K. Nilsson, J. Zackrisson, L. Håkansson, and I. Gustafsson, "Virtual Instrument Systems in Reality (VISIR) for Remote Wiring and Measurement of Electronic Circuits on Breadboard," *Learning Technol.*, IEEE Trans. No 1, vol. 6, pp. 60-72, 2013.
- [4] I. Gustavsson, K. Nilsson, J. Zackrisson, J. Garcia-Zubia, U. Hernandez-Jayo, A. Nafalski, Z. Nedic, Ö. Gö, J. Machotka, M. I., Pettersson, T. Lagö and L. Håkansson, "On objectives of instructional laboratories, individual assessment, and use of collaborative remote laboratories", *IEEE Transactions on Learning Technologies*, 2(4), 263-274, 2009. <http://dx.doi.org/10.1109/TLT.2009.42>
- [5] I. Gustavsson, T. Olsson, H. Åkesson, J. Zackrisson, and L. Håkansson, "A Remote Electronics Laboratory for Physical Experiments using Virtual Breadboards", *Proceedings of the 2005 ASEE Annual Conference*, Portland, USA, June 12 - 15, 2005.
- [6] I. Gustavsson, J. Zackrisson, and T. Olsson, "Traditional Lab Sessions in a Remote Laboratory for Circuit Analysis", *Proceedings of the 15th EAEEIE Annual Conference on Innovation in Education for Electrical and Information Engineering*, Sofia, Bulgaria, 27th - 29th May 2004.
- [7] J. Garcia-Zubia, I. Gustavsson, U. Hernandez-Jayo, P. Orduña, I. Angulo, and J. Ruiz de Garibay, "El proyecto VISIR en la Universidad de Deusto: laboratorio remoto para electrónica básica" *actas del IX Congreso de Tecnologías Aplicadas a la Enseñanza de la Electrónica (TAEE)* ISBN:978-84-96737-67-9 Madrid, Abril 2010.
- [8] Singhal, A.C, Bellamy, L. and McNeill, B. "A New Approach to Engineering Education", *Arizona State University*, Arizona, pp. 88, 1997.
- [9] Feisel, L., and Peterson, G.D., "A Colloquy on Learning Objectives for Engineering Educational Laboratories," *2002 ASEE Annual Conference and Exposition*, Montreal, Ontario, Canada, June 16-19, 2002.
- [10] Teresa Restivo and Gustavo R. Alves, Chapter 13. "Acquisition of higher-order experimental skills through remote and virtual laboratories". Editors: Olga Dziabenko and Javier García-Zubía. *Universidad de Deusto*, Bilbao, 2013. pp. 321-347. ISBN 978-84-15759-16-4.

AUTHORS

Salaheddin Odeh, Mahasen Anabtawi, and Labib Arafah are with the Department of Computer Engineering, Faculty of Engineering, Al-Quds University, Abu Dies, Jerusalem, Palestine (sodeh|manabtawi|larafah@eng.alquds.edu).

Gustavo Ribeiro Alves is with the School of Engineering - Polytechnic of Porto, Porto, Portugal (gca@isep.ipp.pt)

Ingvar Gustavsson is with Blekinge Institute of Technology, Blekinge, Sweden (Ingvar.gustavsson@bth.se)

This paper is an extended version of a paper entitled as "Experiences with Deploying VISIR at Al-Quds University in Jerusalem", presented at IEEE EDUCON 2014: 2014 IEEE Global Engineering Education Conference (EDUCON), 3-5 April, Istanbul, Turkey. Submitted 21 October 2014. Published as resubmitted by the authors 25 January 2015.