

BUOYANT ENERGY – BALANCING WIND POWER AND OTHER RENEWABLES IN EUROPE’S OCEANS

Robert Klar*, Markus Aufleger*, Tonio Sant[†], Valerie Neisch*, Robert N. Farrugia[†]

* Department of Civil Engineering Sciences, Unit of Hydraulic Engineering, University of Innsbruck, Austria

[†] Department of Mechanical Engineering and Institute for Sustainable Energy, University of Malta, Malta

Email address of corresponding author: robert.klar@uibk.ac.at

Keywords: hydraulic energy storage, offshore, decentralised

Abstract

Buoyant Energy is a new approach to store electrical energy offshore and at a decentralised location, based on the well-established technologies of pumped-storage hydro-power. The following work focuses on the basic concept and discusses some of the key features addressed. The unique adaptability and important synergies with other offshore activities are discussed. A basic cost assessment estimates the life cycle costs in order to demonstrate the economic feasibility. Finally, a case study evaluates the effects of integrating deep offshore wind balanced by Buoyant Energy units in a central Mediterranean archipelago’s electricity generating system.

1 Introduction

Reliable access to cost-effective electricity is the backbone of a modern economy. Without significant investments in electrical energy storage, the envisioned transformational changes towards a sustainable electric grid infrastructure are at risk. The lack of efficient and cost-effective energy storage technologies is a serious barrier to keeping pace with the increasing demands for electricity arising from continued growth in productivity and increase in distributed renewable energy sources. Marine renewable energy is one particular field that is expected to contribute significantly to the energy mix of the future. However, no suitable offshore local energy storage solution for the direct integration of such volatile energy sources has a proven track record and the ones under development have serious drawbacks. The mentioned problems affect offshore project development plans in many European regions. Thus, there is a transnational need for action in this respect.

2 Vision

Buoyant Energy¹ (BE) is an offshore energy storage solution based on pumped-storage hydro-power (PSH) technology. Today storage of electrical energy is provided by PSH systems only (over 99 % in Europe and worldwide [1]). When

used onshore, this well-established technology has outstanding features, but is restricted to mountainous regions with water resources that are readily available. BE transfers the PSH key features to an offshore environment. It can be used in a decentralised and distributed way close to offshore renewables, is very effective, durable and robust. BE has the potential to enable an optimized integration of renewable energy sources (Figure 1). As a consequence, positive effects on the regional and wider-ranging infrastructure for electricity supply can be expected.

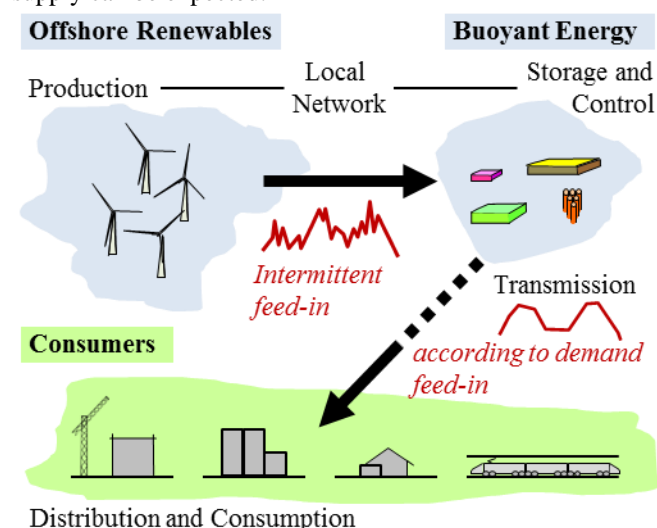

Figure 1: Buoyant Energy (BE) – Typical value chain

3 Concept and Technology

3.1 Basic Concept

The major differences when compared to conventional PSH technology are the basic arrangement and the location of the reservoirs. While conventional PSH systems consist of an upper and a lower reservoir, BE uses a smaller reservoir (the inside space of a floating structure), located within a larger reservoir (the sea or a lake). Water can be moved from one reservoir to the other by means of pumps and turbines or a pump turbine (Figure 2 and Figure 3). The required head (the vertical difference between an upper water level and a lower water level) is defined by the weight and the shape of a floating structure. The inside space of the structure serves as lower reservoir.

¹Official website: www.buoyant-energy.com/

A pump turbine is installed in the lower part of the structure. Water is pumped from the inside space to the sea as a means of energy storage. As a consequence the structure becomes more buoyant and moves up (Figure 3). Allowing water to flow into the structure drives the turbine, generates energy and allows the structure sink (see Figure 2). Typically the head remains approximately constant all the time.

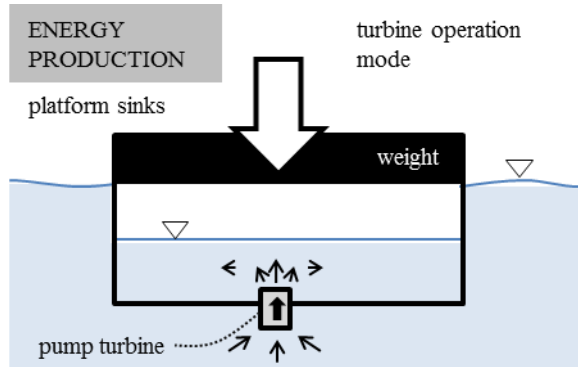

Figure 2: Basic technical concept (Energy production)

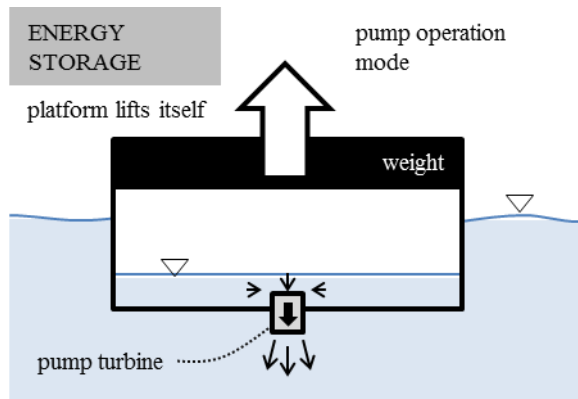

Figure 3: Basic technical concept (Energy storage)

BE is a robust system with a floating platform built from a suitable construction material, typically concrete. Floating concrete structures are economical to build and maintain. The existing offshore industry (oil and gas) as well as coastal construction industry (e.g. submerged tunnel construction) have a lot of experience with large floating concrete structures. While weight is a disadvantage for many floating structures, it is essential in this case to maximise the energy storage capacity of the BE system. BE aims to combine alpine hydropower experiences and offshore concrete technology.

The structure weight and the geometry ensure an appropriate initial immersion depth. The water level inside is significantly lower compared to the outer sea level. The water level difference i.e. the available head, is a decisive parameter for the pump/turbine system. The inside volume and the head difference are critical parameters determining the energy storage capacity.

3.2 Pump/turbine system

Pump/turbine systems of common pumped-storage hydropower systems are designed for relatively high pressure heads and high discharge rates. For this reason, the pump/turbine systems to be used for BE, have to be adapted to the specific hydraulic boundary conditions and additionally to the marine environment that they will operate in. Nevertheless, the system's efficiency can be improved through the transfer of existing knowledge from pump/storage technology. The reverse operation of pumps became an important issue within the fluid machinery industry. Additionally the development of specific axial pump turbines is an option for future BE equipment. In the sense of a distributed approach with a high number of projects, BE is striving for economic and modular solutions. That is why standardized, possibly non-regulated pump/turbine systems could be favourable. Cost optimization is a major issue for the choice of the best mechanical engineering equipment. The layout of the pump/turbine system has to consider, among others, the specific hydraulic boundary conditions (e.g. cavitation), the possibility for revision and fish protection.

3.3 Efficiency, cycles and self-discharge

Due to the simple architecture of the structure and the direct connection of the pump/turbine system to both reservoirs, energy losses are expected to be very little. Only minimal hydraulic losses will result, mainly from turbulences at the outer inlet/outlet and inside the structure. Thus, the system efficiency, for example the round trip efficiency, mainly depends on the applied pump/turbine system. It is expected that the motion of the platform under rough wave conditions will not harm the efficiency of the storage system in a significant way due to the fact, that the driving factor is the external wave-related energy. In addition, potential effects on the hydraulic losses during both turbine mode and pump mode operation have to be investigated.

As a consequence of the specific hydraulic conditions and the direct hydraulic link between the outer sea water and the reservoir, the pressure head typically remains relatively constant (dependent on the shape and the thickness of the structure walls) during the whole cycle (from the lowest to the highest position). This favourable technical boundary condition should allow an optimized pump/turbine system to operate highly efficiently at any given time.

Due to these boundary conditions it can be assumed that the system efficiency of Buoyant Energy will be even better compared to conventional pumped-storage hydropower systems. Round trip efficiencies of more than 80% can be expected. High degree efficiency is an important issue for the performance of the system.

Compared to pumped-storage hydropower system the number of cycles is practically unlimited. There is no self-discharge or any long-term reduction of efficiency to be expected.

3.4 Adaptability

BE can provide customized storage solutions with a high adaptability to local boundary conditions (e.g. water depth, sea conditions, requirement for local energy storage). The technical concept is very flexible and can be integrated in nearly any geometry of multi-use offshore platforms. Therefore many potential synergies of large BE structures and directly linked technologies (e.g. additional use as a service and operation platform for offshore wind farms) or even other economic sectors (oil and gas, other industry, fisheries, tourist and leisure, housing, etc.) can be identified. However, there are some characteristics to consider:

- The system performance significantly depends on the usable pressure head difference. For example, a rectangular concrete structure having sides of 50 m by 50 m and a height of 38 m (34,000 tonnes), stores the energy capacity of 1 MWh, with an assumed additional load of 36,000 tonnes on the platform (see Figure 4). The same amount of energy could be stored in other rectangular (e.g. Figure 5) or cylindrical platforms (e.g. Figure 6 and Figure 7). Power rating will be chosen according to the required run time (e.g. of the order of one hour to a few hours).
- In the case of relatively shallow and wide structures (e.g. Figure 4, Figure 5 or Figure 7), the pressure head remains relatively constant. For structures with significant draughts (e.g. Figure 6), the head is as great as the highest position of the structure during the cycle.
- The less structural material beneath the sea water level, the lower the related buoyancy is. This leads to a higher usable head (water level difference).
- The thinner the underwater buoyant structure material (i.e. the closer the ratio between the water area and the overall area in a horizontal cross section underwater is to 1.0), the more constant is the head during operation (e.g. Figure 5).
- The energy storage capacity reaches its maximum, presuming that the external dimensions are equal, if at maximum immersion depth, the cavity is half full with water (see Figure 6).
- It is important to keep a sufficient safety factor against sinking. A freeboard of a couple of meters has to be ensured. This aspect is subject to further research.
- The shape and thus the geometry of the load above the water level does not affect the operation of the energy storage system, which depends on its weight only. Thus, synergies with other economic sectors are technically possible.
- In order to determine of the best geometry, a number of important issues have to be considered (e.g. stability, weather and sea conditions, specific material costs, construction methods, potential synergies, etc.).

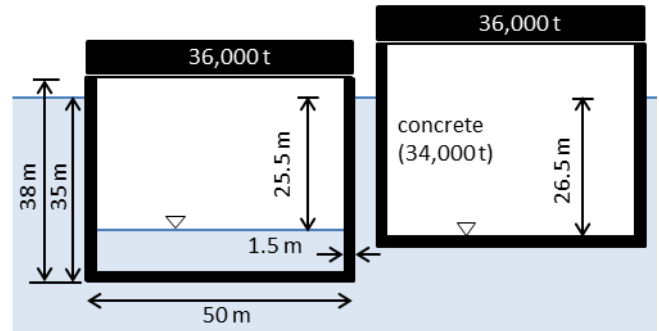

Figure 4: Example of the geometry for rectangular floating concrete platforms with external loads (Energy Storage Capacity ~1 MWh). Pump/turbine systems are not shown.

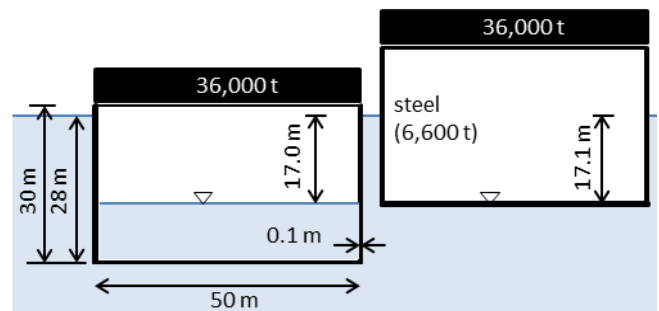

Figure 5: Schematic showing the geometry for rectangular floating steel platforms with external loads (Energy Storage Capacity ~1 MWh). Pump/turbine systems are not shown.

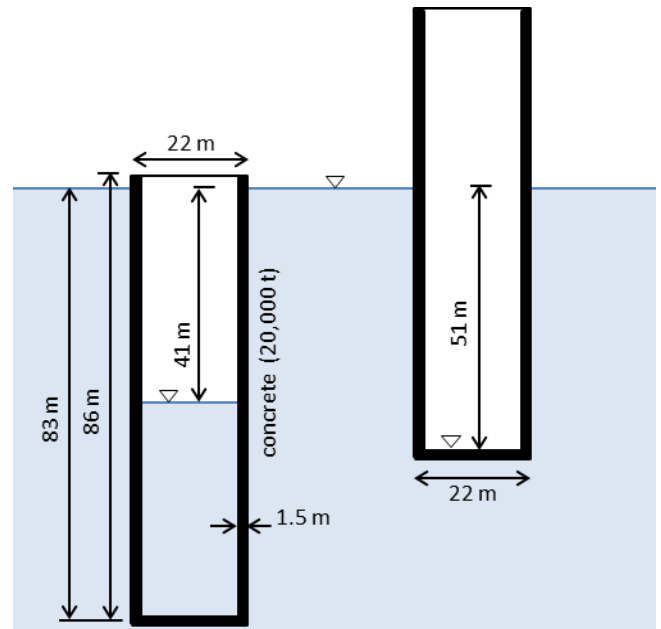

Figure 6: Example of the geometry for cylindrical floating concrete platforms (Energy Storage Capacity ~1 MWh). Pump/turbine systems are not shown.

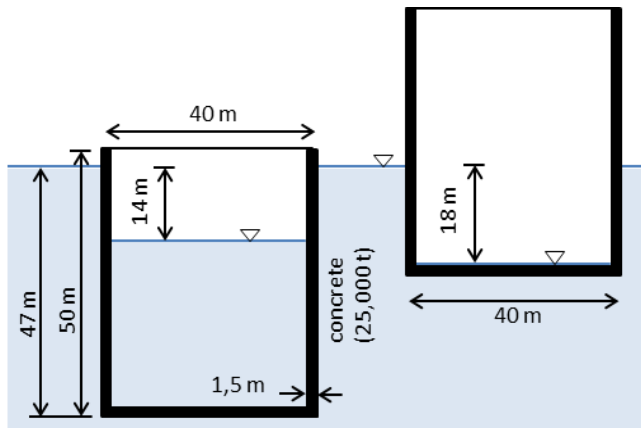

Figure 7: Geometry for cylindrical floating concrete platforms (Energy Storage Capacity ~1 MWh). Pump/turbine systems are not shown.

The technology allows creating special solutions like energy storage clusters, where single module structures are mechanically and/or hydraulically linked. By applying this configuration it is possible to reduce the installed number of pump/turbine systems and thereby the costs.

Furthermore it could be favourable to have a significant number of unregulated pump/turbine systems – possibly having different power ratings - connected with a relatively large internal reservoir (e.g. consisting in a number of floating platform modules with hydraulically connected inside spaces). The system control could be implemented according to the grid requirements by starting and stopping the appropriate pump/turbine systems.

3.5 Cost Assessment

As cost efficiency is one of the main goals, the life cycle costs of the Buoyant Energy system have been estimated. In a first approach, the minimum operational lifetime was assumed to be 20 years, though experience with floating concrete structures shows that this is a very cautious assumption. Depending on the construction method and design quality lifetimes above 50 years can be assumed. The durability of reinforced concrete under sea water conditions mainly depends on the protection of the steel reinforcement against corrosion.

Figure 8 shows a bandwidth of life cycle costs for a BE cylindrical structure with a height of 40 m, a platform area of 4,500 sq. m., an energy capacity of 5 MWh, pump/turbine system power of 800 kW and a total weight of 90,000 tons based on simplified assumptions and 500 random scenarios (each with two full load cycles per day and a round trip efficiency of 80%, equivalent to 2.9 GWh of stored electric energy per year). Therefore, mainly unit prices and their possible price span are estimated according to rough empirical data. In addition to the construction costs, costs for the pump/turbine system, the mooring system, the electric grid connection, operation, maintenance and financing are taken into account. The major part of the life cycle costs are

related to the concrete structure of the floating platforms. Research to find customized solutions to reduce construction costs is required.

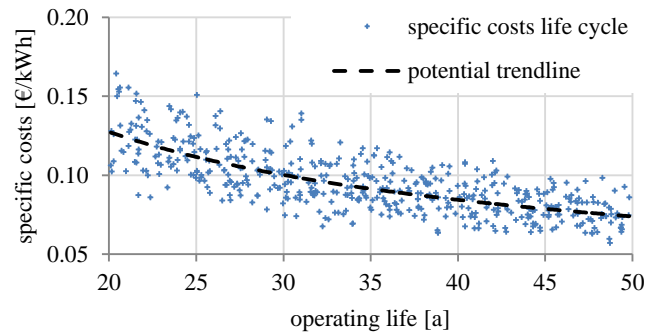

Figure 8: Estimated specific life cycle costs (LCC) depending on operating life (Illustration of a rough estimate)

In order to demonstrate the economic feasibility of the BE concepts, two benefits are discussed. First, floating BE platforms can provide multi-use space on the platform roof and inside the structure. This space can, for example, be used for service and operational needs next to offshore wind farms, be equipped with a helipad, fish farming/aquaculture, leisure or accommodation facilities. Nearer to cities, clusters of BE floating platforms can offer commercial building and housing areas to potential customers (e.g. Figure 9). To estimate the span of possible benefits, earnings are varied between 100 and 200 € per m² top platform area per year.

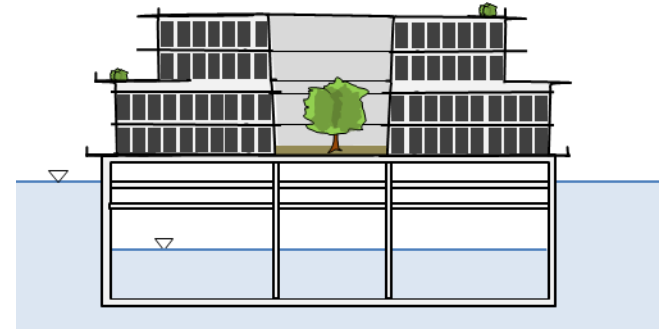

Figure 9: Schematic sketch of a BE platform providing space for potential residents (floating city)

Secondly, the benefit of the direct marketing of electricity to balance supply and demand and to overcome the intermittency of renewable energy sources is estimated, based on the amount of stored electric energy per time period. Therefore, the specific direct marketing earnings are varied between 0.05 and 0.1 € per kWh of stored electric energy.

Figure 10 summarizes the resulting total life cycle costs and earnings from 500 randomized generated scenarios (each with two load cycles a day and a round trip efficiency of 80%). The trend lines cross approximately at an operating life of ten years. Despite all rough estimates which this analysis is based on, it is shown that the break-even point is reached within the operation lifetime of the installation.

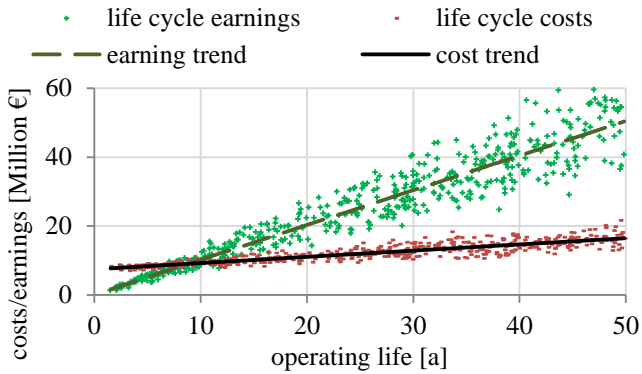

Figure 10: Estimated life cycle costs and earnings depending on operating life (Exemplary illustration of a rough estimate)

4 Integration into offshore wind farms

At the time of writing, regular offshore wind farms are being installed exclusively in shallow offshore areas. The wind turbine support structures are bottom-mounted on the seabed. BE structures could be placed between the wind turbines. The electrical connections to the wind turbines would be done via flexible sea cables. Floating energy storage platforms could be placed at numerous suitable positions within the cable network which has to connect the numerous wind turbines with the long distance cables to the coast.

There is a significant interest today to develop floating offshore wind turbine (FOWT) technology. This will allow the exploitation of wind energy at deep offshore sites, further away from the coast, where wind farm consenting is expected to be less problematic. The integration of the BE concept in the support structure of floating wind turbines is a next step for further research (see Figure 11). If every floating wind turbine has access to its own energy storage unit, the overall system becomes more flexible. BE could provide short-term storage enabling the intermittent power output from the turbine to be converted into a constant power source over pre-determined time intervals, hence mitigating problems normally associated with grid integration of conventional wind energy systems.

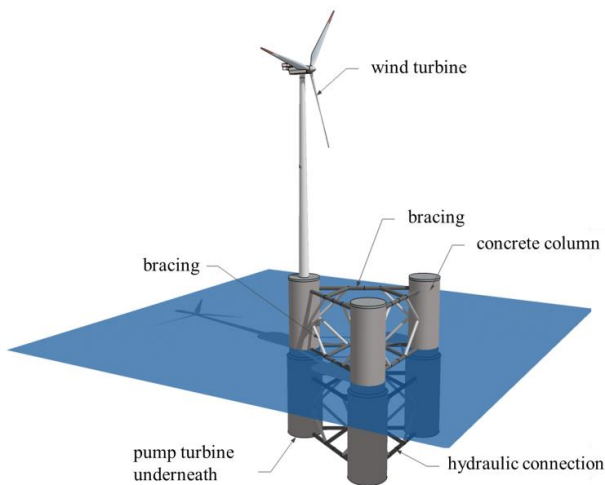

Figure 11: Floating wind turbine – Buoyant Energy integrated into the floating foundation

The Mediterranean Sea presents significant potential to operate large BE platforms due to the availability of vast areas of deep water. A case study evaluating the energy storage capacity required for a typical 5 MW FOWT operating in the Maltese waters in the Central Mediterranean is presented. The FOWT was modelled to operate over a five year period (2007 - 2011) at an offshore site having a sea depth of 200 m, located around 10 km to the south west of Malta (Figure 12).



Figure 12: Map of the Maltese Islands indicating deep offshore site under consideration, Wied Rini and Ahrax Point (Map source: Google Earth, Accessed May 2015)

Wind speed estimates at 90 m above mean sea level (m.s.l.) for this offshore site were derived through the combined use of land-based measurements and Computational Fluid Dynamics (CFD) projections. Long-term wind speed and direction records from 10 m above ground level (a.g.l.) at Wied Rini and shorter-term measurement records at 80 m a.g.l. from Ahrax Point [2] were used in a Measure-Correlate-Predict (MCP) method using the WindPRO [3] software. This projected dataset was then used in the CFD software suite WindSim [4] to model the wind resources at the offshore site, with a macro domain covering the Maltese Islands. The 5-year average wind speed was estimated to be 7.29 m/s at 90 m above m.s.l.

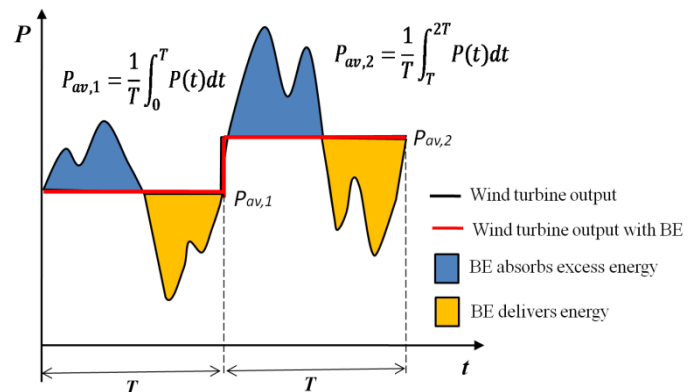

Figure 13: Constant power production from a wind turbine over short time intervals (T) through the integration of BE.

The resulting time series wind speed data, consisting of 10 minute average values, was used in conjunction with the power curve for the NREL 5 MW wind turbine [5] to predict the generated electrical power with time. The BE storage system was assumed to average the power output over a specified short time interval T as explained in Figure 13. The energy flows in and out of the BE system required to maintain constant power output over a short time interval T were computed. The computations were undertaken for the entire 5-year period and repeated for T equal to 1, 2 and 3 hours. Typical time variations for the power output are shown in Figure 14.

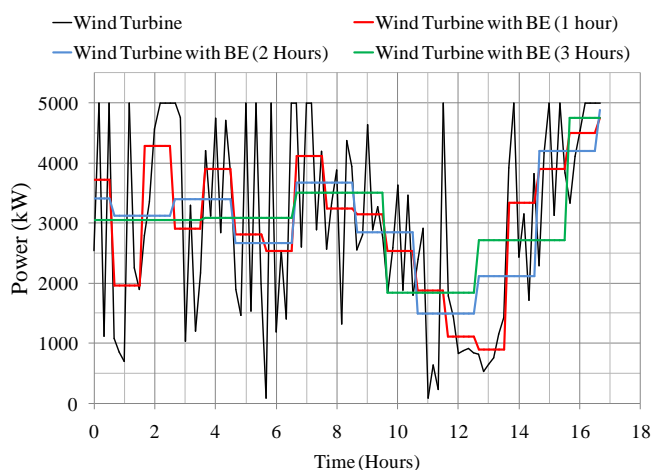

Figure 14: Output power with time from a 5 MW FOWT (with and without BE Storage)

The energy storage capacity required was taken to be equal to the maximum amount of energy stored in a 10 minute interval across the entire five year period. It may be observed that increasing the interval T would decrease the fluctuations in the output power, at the expense of an increased energy storage capacity requirement. However, as may be observed in Figure 15, such storage requirements are within realistic limits that can be handled by typical BE structure dimensions discussed in the earlier sections. It should be noted that energy losses incurred in BE operation (pump/turbine losses) are being ignored in this simple analysis.

Consequently the storage capacity estimates given in Figure 15 are somewhat conservative.

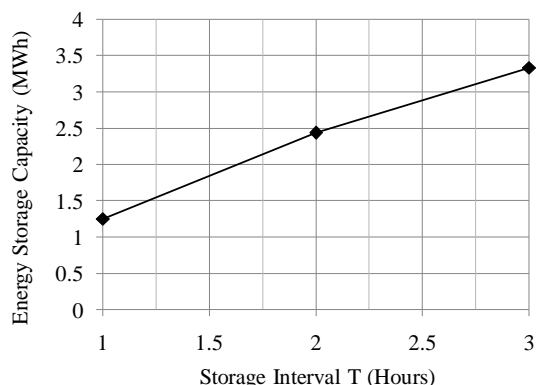

Figure 15: Energy Storage Capacity Requirements

Acknowledgements

The authors are indebted to the Malta Resources Authority for providing the University of Malta with wind measurement data from the 80 m wind monitoring mast at Ahrax Point.

References

- [1] IEA (International Energy Agency) analysis and EPRI (Electric Power Research Institute) (2010), "Electrical Energy Storage Technology Options", Report, EPRI, Palo Alto, California, USA.
- [2] Malta Resources Authority, Triq Aldo Moro, Marsa, Malta.
- [3] "WindPRO™ Ver. 2.7," 2008, EMD, Aalborg, Denmark.
- [4] WindSim™, Ver. 5.01.1, 1997 - 2010, WindSim AS, Tønsberg, Norway.
- [5] J. Jonkman, S. Butterfield, W. Musial and G. Scott, "Definition of a 5-MW reference wind turbine for offshore system development," National Renewable Energy Laboratory (NREL), Tech. Rep. NREL/TP-500-38060, February 2009.