



INSTITUTE FOR Sustainable Energy, UNIVERSITY OF MALTA

**SUSTAINABLE ENERGY 2015:  
THE ISE ANNUAL CONFERENCE**Tuesday 17<sup>th</sup> March 2015, Dolmen Resort Hotel, Qawra, Malta**COMPARING THE ECONOMIC FEASIBILITY OF OFFSHORE FLOATING WIND AND  
SOLAR PHOTOVOLTAIC TECHNOLOGIES IN CENTRAL MEDITERRANEAN DEEP WATERS**P. Vella<sup>1</sup>, T. Sant<sup>2</sup> and R. N. Farrugia<sup>1</sup><sup>1</sup>Institute for Sustainable Energy, University of Malta, Triq il-Barrakki, Marsaxlokk MXK1531, Malta.

Tel: (+356) 21650675, (+356) 21652249, Fax: (+356) 21650615

Corresponding Author E-mail: [vellapp@gmail.com](mailto:vellapp@gmail.com)<sup>1</sup> & <sup>2</sup> Department of Mechanical Engineering, University of Malta Msida MSD2080, Malta.

**ABSTRACT:** Malta, being a very small and densely populated island in the central Mediterranean, has little space for large scale onshore wind turbine or photovoltaic projects. Maltese territorial waters are mostly too deep for conventional offshore wind farms to be constructed save for a handful of near-shore reefs and shoals. The quest for offshore wind turbine structure designs capable of being installed in deeper waters will revolutionize prospects for offshore wind projects worldwide; but even more so in the Mediterranean region. This paper presents a preliminary engineering analysis to develop two cost-optimized offshore floating structures to support (1) a single multi-megawatt scale wind turbine and (2) a solar photovoltaic farm with the same energy production as that of the single wind turbine. The primary objective of this work is to determine the most economically feasibility option for harvesting renewable energy at sea: offshore wind or offshore solar photovoltaic energy.

**Keywords:** Offshore, Wind, Photovoltaics**List of Abbreviations**

CAPEX	Capital Expenditure	NREL	National Wind Energy Laboratory
COB	Centre of Buoyancy	O&M	Operations and Maintenance
COG	Centre of Gravity	OM	Overturning Moment
FBD	Free Body Diagram	OPEX	Operational Expenditure
FOWT	Floating Offshore Wind Turbine	Op	Operational Conditions
LCOE	Levelised Cost of Energy	OWT	Offshore Wind Turbine
MAX	Maximum	RAO	Response Amplitude Operator
MIN	Minimum	RM	Righting Moment
MC	Metacentre	Su	Survival Conditions
MW	Megawatts		

**1 INTRODUCTION**

This paper is based on preliminary calculations for the design of a floating platform to carry a wind turbine or the equivalent number of photovoltaic panels in Mediterranean conditions. Calculations based on hydrostatics, stability theory and Morrison's equation for wave loading were carried out on the general arrangement and overall hull design taking into consideration wind and wave loading, weight, buoyancy and stability, mooring arrangements, static analysis, and cost. The support structure has been proposed as a conceptual semi-submersible unit with twin pontoons and a deck on four supporting columns. Load calculations were undertaken at operational wind speeds of 25 ms<sup>-1</sup> and at an extreme 42.5 ms<sup>-1</sup>, this being the reference speed for a Class 2 wind turbine in the IEC wind class classification. All

calculations were carried out through a linear iterative model which was set up using the solver algorithms of Microsoft Excel [1] whereas the STAAD Pro Ver. 8i [2] software was used to undertake static analysis and determine deflections, compressive, tensile and shearing forces and bending moments. The final part of the analysis consisted of formulating a cost model for each of the two platform types and to estimate the levelised cost of energy (LCOE) for both floating wind and solar PV in the deep offshore environment.

**2 OFFSHORE FLOATING STRUCTURE  
INSTALLATIONS****2.1 Offshore Wind Platforms**

Offshore wind platforms can be categorised as shown in Figure (1).

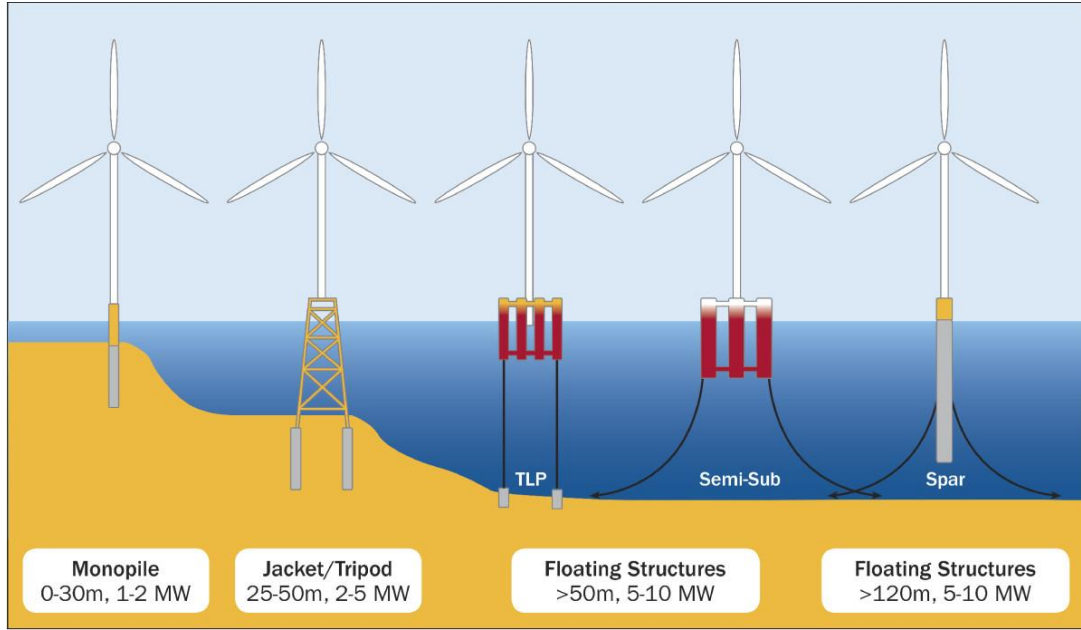

Figure (1): Types of Offshore Wind Platforms [3].

Offshore floating wind turbine concept designs have been proposed and set up since 2003 in various countries ranging from 120 MW to 630 MW [4].

## 2.2 Offshore Photovoltaic Platforms

Floating PV technology is a relatively new concept. A number of projects have been set up in lakes but no commercial deployments have been undertaken to date in the open sea.

## 3 THEORETICAL BACKGROUND

### 3.1 Hydrostatics and Stability

Figure (2) refers to the basic stability principles for floating structures.

From Newtonian fluid mechanics it can be shown that the period in heave is:

$$p_t^{\text{HEAVE}} = ((\Delta_t + w^{\text{AM,HEAVE}}) / (\rho g a_t^{\text{WATERLINE}}))^{1/2} \quad \dots (1)$$

$p_t^{\text{HEAVE}}$	Eigen period in heave in condition t
$\Delta_t$	Weight displacement in condition t
$w^{\text{AM,HEAVE}}$	Total added mass in heave
$\rho$	Density of sea water
$g$	Gravitational acceleration
$a_t^{\text{WATERLINE}}$	Water plane area in condition t

Similarly,

$$p_t^{\text{ROLL}} = ((\Delta_t + w^{\text{AM,HEAVE}}) / (\rho g a_t^{\text{WATERLINE}}))^{1/2} \quad \dots (2)$$

$p_t^{\text{ROLL}}$  Eigen period in heave in condition t.

$$p_t^{\text{PITCH}} = ((\Delta_t + w^{\text{AM,HEAVE}}) / (\rho g a_t^{\text{WATERLINE}}))^{1/2} \quad \dots (3)$$

$p_t^{\text{PITCH}}$  Eigen period in heave in condition t.

### 3.2 The Objective Function

The objective function for the iterative process is,

$$Z_{\text{Minimise}} = W^P + W^C + W^B + W^D \quad \dots (4)$$

where:

Z	Hull Weight
$W^P$	Weight of Pontoons
$W^B$	Weight of Braces

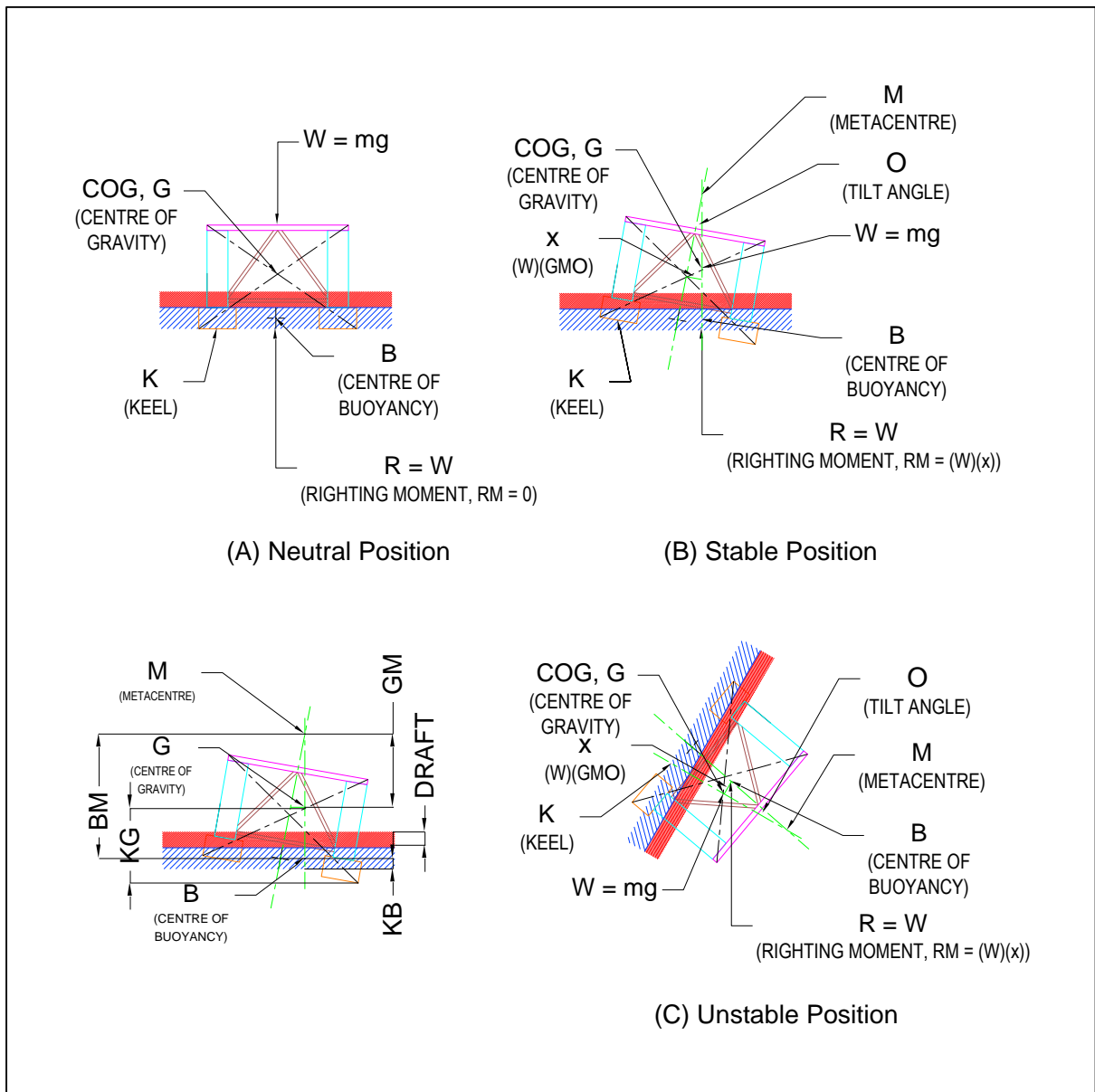

**Figure (2):** Hydrostatic Equilibrium of a Rigid Floating Body.

$W^C$  Weight of Columns  
 $W^D$  Weight of Deck

structures was constrained geometrically in the iteration by the condition that,

$$GM = KB + BM - KG; GM > 0 \quad \dots (5)$$

Various constraints were used in the process of achieving a minimised weight. Most important was the restriction of the periods in heave, roll and pitch within acceptable limits of low energy when referred to a typical wave response amplitude operator curve [5].

where:

GM Vertical distance from the COG to the MC  
 KG Vertical distance from the keel to the COG  
 KB Vertical distance from the keel to the COB  
 BM Vertical distance from the COB to the MC

### 3.3 Structure Stability

The balance of forces on each of the designed

Physically, the mooring system calculations were done such that:

Righting Moment (RM) > Overturning Moment (OM)  
Figure (3) and Figure (4) show the respective forces.

### 3.4 Structure Analysis

Static analysis to come up with forces and deflections in the respective members has been done using STAAD Pro v8i. The analysis considered only forces as calculated for extreme conditions.

Static catenary line theory was used to carry out a mooring analysis<sup>[16]</sup> to determine the typical mooring system which would be used for these semi-submersible floating structures.

### 3.5 Levelised Cost of Energy (LCOE)

The LCOE is the minimum cost of energy that must be charged for each unit of energy produced to ensure that all costs are recovered over the lifetime of the system. Profit is ensured by including a margin on the LCOE and discounting future revenues at a discount rate that equals the rate of return that might be gained on other investments of comparable risk, i.e. the opportunity cost of capital.

$$\frac{\sum_{t=1}^{t=N} \text{LCOE} * Q_t}{(1 + d_0)^t} = \sum_{t=0}^{t=N} \frac{C_t}{(1 + d_0)^t} \quad \dots (6)$$

- N Analysis period.
- Q<sub>t</sub> Amount of energy production in period t.
- C<sub>t</sub> Cost incurred in period t
- d<sub>0</sub> Discount rate or opportunity cost of capital.

In general, fabrication costs are given by the following:

$$C_T = C_M + C_L + C_O \quad \dots (7)$$

- C<sub>T</sub> Total Building Costs
- C<sub>M</sub> Material Costs Costs of all purchased materials which are incorporated in the final product.
- C<sub>L</sub> Labour Costs Labour costs are defined as costs directly related to man-hours expended during the operating of production facilities within a work-station.

- C<sub>O</sub> Overhead Costs Costs directly or indirectly related to the operation and upkeep of the construction yard.

## 4 DESIGN RESULTS

### 4.1 Site Environmental Conditions

A complete design analysis of an offshore installation would entail calculations to account for the dynamic coupling between translational (surge, sway, and heave) and rotational (roll, pitch, and yaw) platform motions and also to turbine motions in the case of a wind turbine, as well as the dynamic characterization of mooring lines for floating systems. Subsets of these studies have been carried out namely on wind and waves as independently acting forces. The bathymetric depth for the proposed semi-submersible is understood to be in the region of 100 m and it will be moored within the 12 nautical mile (22 km) boundary to the South East of Malta. Table (1) summarises the environmental conditions as referenced in this report.

**Table (1):** Summary of Modelled Environmental Conditions<sup>[6]</sup>.

Environmental Condition		Operational (Op)	Survival (Su)
Wind Speed	ms <sup>-1</sup>	25	42.5
Wind & Wave Direction	-	45 <sup>0</sup>	45 <sup>0</sup>
Wave Period	s	1.7	7.1
Wave Height, H <sub>s</sub>	m	0.95	4.1
Wavelength	m	4.51	78.64
Wave Speed	ms <sup>-1</sup>	2.65	11.08

### 4.2 Wind Turbine Platform Calculations

The wind turbine chosen for the iterative calculations was the NREL 5 MW machine<sup>[18]</sup> generating 12.7 GWh annually under central Mediterranean climatic conditions.

Table (2) shows the geometrical dimensions of the iterative calculations whilst Figures (5) and (8) refer.

The loads calculated to be acting on the structure are noted in Table (3) whilst the moment forces are noted in Table (4) and Table (5). The mooring configuration is noted in Table (6).

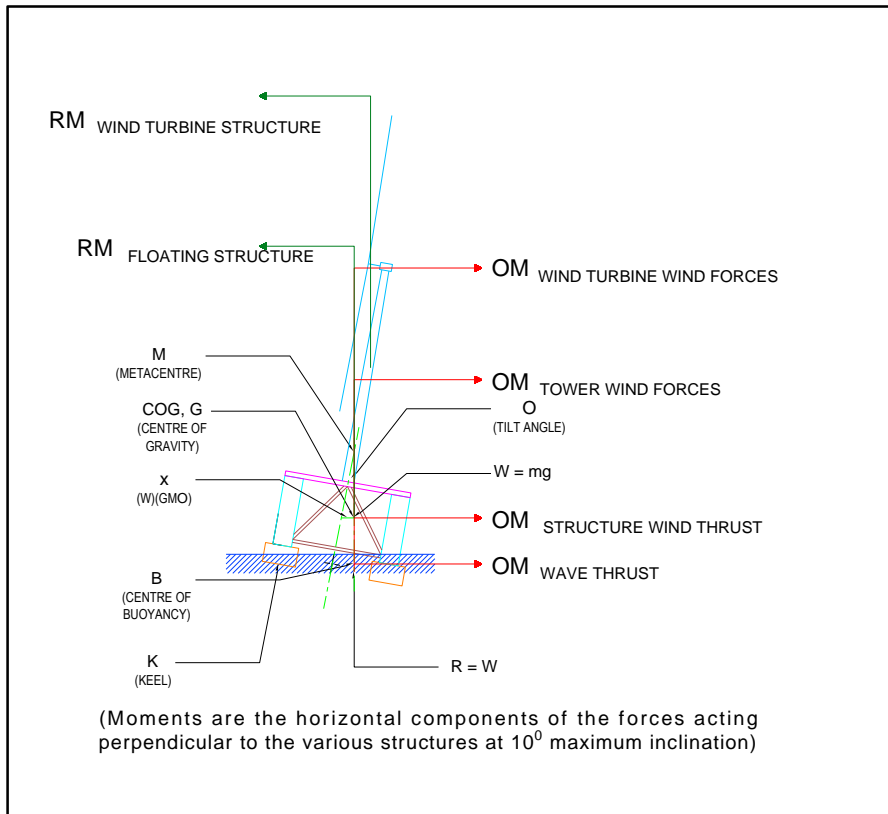

**Figure (3):** OM and RM Forces of Wind Turbine Structure.

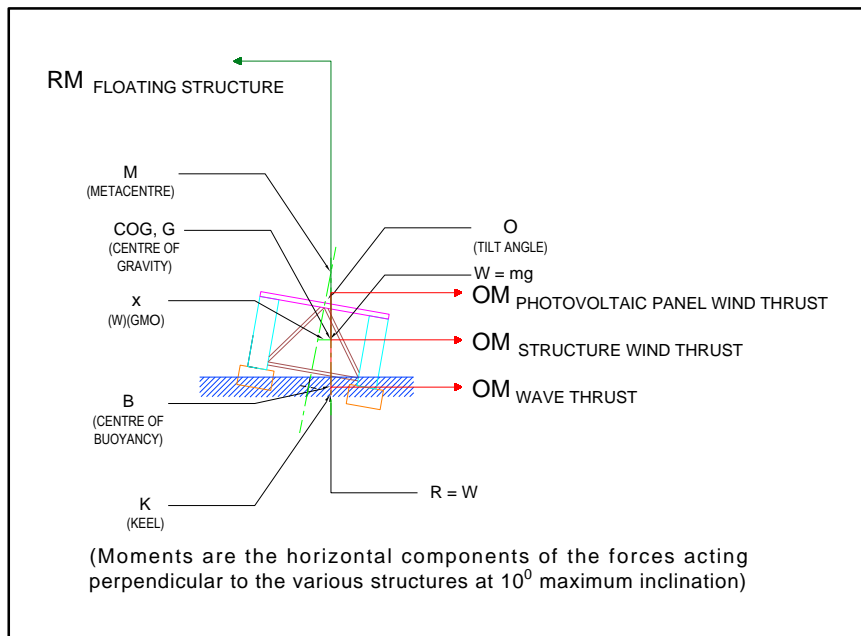

**Figure (4):** OM and RM Forces of Photovoltaic Structure.

**Table (2):** Iterative Calculations for the Wind Turbine Installation.

Steel Weight	Tonnes	2,799
DeckArea	m <sup>2</sup>	2,728
l <sub>p</sub> Pontoon Length	(m)	59.13
h <sub>p</sub> Pontoon Height	(m)	8.00
b <sub>p</sub> Pontoon Breadth	(m)	14.60
l <sub>c</sub> Column Length	(m)	7.71
h <sub>c</sub> Column Height	(m)	20.27
b <sub>c</sub> Column Breadth	(m)	7.71
d <sub>p</sub> Distance between Pontoons	(m)	44.52
d <sub>c</sub> Distance between Columns	(m)	44.52
ω <sub>n, Heave</sub>	(rads <sup>-1</sup> )	0.31
ω <sub>n, Roll</sub>	(rads <sup>-1</sup> )	0.09
ω <sub>n, Pitch</sub>	(rads <sup>-1</sup> )	0.09

**Table (3):** Applied Loads for the Wind Turbine Installation.

Dead Load (Op/ Su)	2.7 kNm <sup>-2</sup> (770 T X 9,81 ms <sup>-2</sup> ) kN/ 2,728 m <sup>2</sup>	NREL machine [44].
Self-Weight (Op/ Su)	N/A	Calculated by STAAD.
Wind Turbine Thrust (Op)	76,562 kN	Wind generated thrust.
Blade Drag (Su)	3,619 kN	Stationary turbine.
Tower Drag (Op/ Su)	19 kN	25 ms <sup>-1</sup> wind speed.
	54 kN	42.5 ms <sup>-1</sup> wind speed.
Static Pressure (Op/ Su)	171 kN	Maximum draft.

Wind Load on the Structure (Op/ Su)	482 kN	Tangential Load at 45 <sup>0</sup> to the Structure applied as a Nodal (Concentrated) Load in the horizontal plane. Heave angle of 4 <sup>0</sup> since this is an operational load.
	1,501 kN	Tangential Load at 45 <sup>0</sup> to the Structure applied as a Nodal (Concentrated) Load in the horizontal plane. Heave angle of 15 <sup>0</sup> since this is a survival load.
Wave Load On the Structure (Op/ Su)	1,444 kN	Calculated using Morrison's equations and applied as a tangential nodal load at 45 <sup>0</sup> .
	4,378 kN	

**Table (4):** Moment Forces for the Wind Turbine Installation in Operational Mode.

T <sub>ACTUAL</sub> (Tensile force used in the mooring line to counteract the overturning forces at a safety factor of 1.2)	kNm	26,000
RM <sub>LONGITUDINAL</sub> (Righting moment force in the horizontal direction)	kNm	9,314,506
OM <sub>WT Forces (Thrust)</sub> (Overturning moment due to the wind turbine thrust force)	kNm	7,851,776
OM <sub>WT Blade Drag</sub> (Overturning moment due to the wind turbine blade drag when turbine is stationary)	kNm	-
OM <sub>WT Tower Drag</sub> (Overturning moment due to the wind turbine tower wind drag)	kNm	1,093
OM <sub>Structure Wind Drag</sub> (Overturning moment due to the structure wind drag)	kNm	9,501

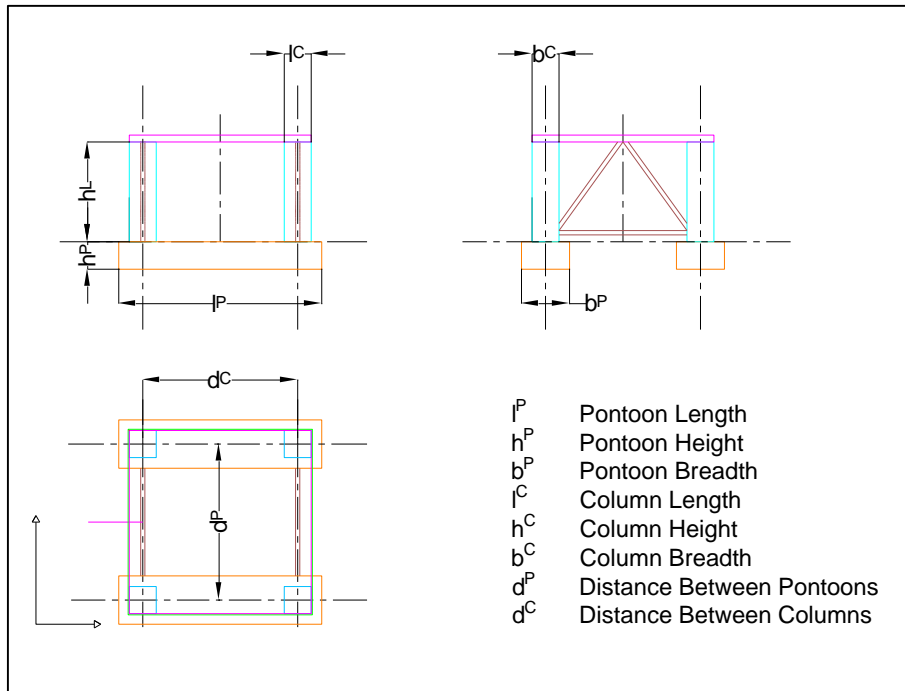

**Figure (5):** Geometrical Dimension of Floating Structures

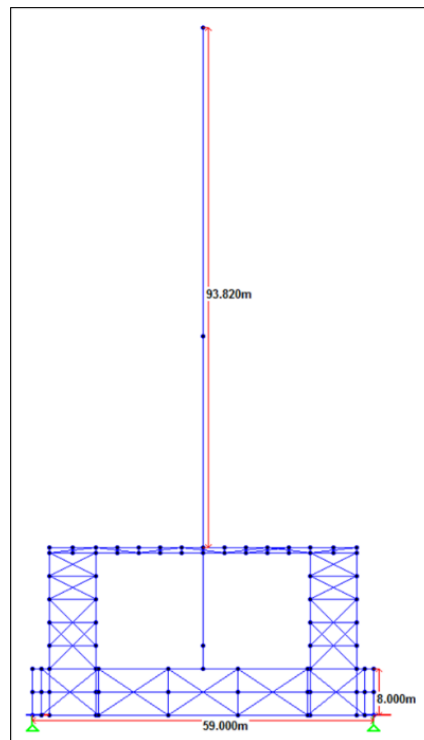

**Figure (6):** Wind Turbine Structure in STAAD.

$OM_{Wave\ Thrust}$ (Overturning moment due to the wave forces on the structure)	kNm	97,728
$OM_{Total}$ (Total overturning moment)	kNm	7,960,582
RM/ OM (Ratio of the righting moment to the overturning moment)	N/A	1.17

**Table (5):** Moment Forces for the Wind Turbine Installation in Survival Mode.

$T_{ACTUAL}$ (Tensile force used in the mooring line to counteract the overturning forces at a safety factor of 1.2)	kNm	1,100
$RM_{LONGITUDINAL}$ (Righting moment force in the horizontal direction)	kNm	393,743
$OM_{WT\ Forces\ (Thrust)}$ (Overturning moment due to the wind turbine thrust force)	kNm	-
$OM_{WT\ Blade\ Drag}$ (Overturning moment due to the wind turbine blade drag when turbine is stationary)	kNm	3,564
$OM_{WT\ Tower\ Drag}$ (Overturning moment due to the wind turbine tower wind drag)	kNm	3,160
$OM_{Structure\ Wind\ Drag}$ (Overturning moment due to the structure wind drag)	kNm	29,594
$OM_{Wave\ Thrust}$ (Overturning moment due to the wave forces on the structure)	kNm	295,951
$OM_{Total}$ (Total overturning moment)	kNm	332,269
RM/ OM (Ratio of the righting moment to the overturning moment)	N/A	1.19

**Table (6):** Mooring Configuration for the Wind Turbine Installation.

Operational	Survival
Four 26,000 kN loaded mooring lines	Four 1,100 kN loaded mooring lines
Drag embedment anchors	Drag embedment anchors

The space truss using members and nodes as set up in STAAD is shown in Figure (5). The structure was set up as members rigidly connected together (welded or bolted depending on further loading analysis and fabrication facilities and respective costs) and loads as noted in Table (3) applied at nodes.

The member type used in the analyses is noted in Table (7), resulting in a total structure weight of 2,980 Tonnes. This compared reasonably well with the weight of 2,799 Tonnes as calculated through the iterative calculations of Microsoft Excel (ver. 2013) [1].

**Table (7):** Material Specifications – Wind Turbine Installation.

Pontoons/ Columns	Deck Beams	Beams (Bracing)	Deck Plates
HD400X551	IPE400	HD400X262	12 mm
1,580	253	890	257

Displacement and shear force and bending moment diagrams were set up in STAAD and in general there were no failures as determined by STAAD when using material properties as noted in Table (8) and considering default safety factors from EN 1993-1-1 of 1.4. One area of concern was the wind turbine column to deck interface which indicated that a more detailed design was necessary.

**Table (8):** Material Constants STAAD Pro V8i.

Name	E kN/mm <sup>2</sup>	Poisson's Ratio	Density Alpha Kg/mm <sup>3</sup>	Density Alpha @°K
Steel	199	300E-3	7,833	18E-6

### 4.3 Photovoltaic Panel Platform Calculations

The equivalent PV capacity needed to generate the same electrical energy to that produced by the wind turbine on an annual basis (12,751,725 kWh) - using solar PV electricity at a generation factor of 1,500 kWh/kWp - would be of 8,500 kWp. Using 300 W<sub>p</sub> polycrystalline photovoltaic panels implies a total of 28,333 panels would be required. Following the geometrical size iterations, it was determined that 18 of the semi-submersible structures would be needed. Performance losses for arrays inclined at 15° and veering off South by around 20° due to yawing were assumed to be 5% [7].

Table (9) shows the results of the iterative calculations, whilst Figure (5) and Figure (9) refer to the respective structural geometries.

The loads which were calculated to be acting on the structure are noted in Table (10) whilst the moment forces are noted in Table (11) and Table (12). The mooring configuration is noted in Table (13).



**Table (9):** Iterative Calculations for the Photovoltaic Installation (Ref. to

Steel Weight	Tonnes	1,420
Deck Area	(m <sup>2</sup> )	4,969
l <sub>p</sub> Pontoon Length	(m)	60.00
h <sub>p</sub> Pontoon Height	(m)	5.00
b <sub>p</sub> Pontoon Breadth	(m)	10.00
l <sub>c</sub> Column Length	(m)	4.50
h <sub>c</sub> Column Height	(m)	5.50
b <sub>c</sub> Column Breadth	(m)	4.50
d <sub>p</sub> Distance between Pontoons	(m)	75.00
d <sub>c</sub> Distance between Columns	(m)	58.00
ω <sub>n, Heave</sub>	(rads <sup>-1</sup> )	0.30
ω <sub>n, Roll</sub>	(rads <sup>-1</sup> )	0.20
ω <sub>n, Pitch</sub>	(rads <sup>-1</sup> )	0.20

**Table (10):** Applied Loads for the Photovoltaic Installation.

Dead Load (Op/ Su)	0.079 kNm <sup>2</sup> (40 T X 9,81 ms <sup>-2</sup> ) kN/ 4,968 m <sup>2</sup>	Total Panel and Aluminium structure.
Self-Weight (Op/ Su)	N/A	Calculated by STAAD.
Static Pressure (Op/ Su)	95 kN	Maximum draft.
Wind Load on the Structure (Op/ Su)	37 kN (52 kN X Cos(45°))	Tangential Load at 45° to the Structure applied as a Nodal (Concentrated) Load in the horizontal plane. Heave angle of 4° since this is an operational load.
	143 kN (202 kN X Cos(45°))	Tangential Load at 45° to the Structure applied as a Nodal (Concentrated) Load in the horizontal plane. Heave angle of 15° since this is a survival load.
Wave Load	634 kN	Calculated using Morrison's

on the Structure (Op/ Su)	1,475 kN	equations and applied as a tangential nodal load at 45°.
---------------------------	----------	--

**Table (11):** Moment Forces for the Photovoltaic Installation in Operational Mode.

T <sub>ACTUAL</sub> (Tensile force used in the mooring line to counteract the overturning forces at a safety factor of 1.2)	kNm	475
RM <sub>LONGITUDINAL</sub> (Righting moment force in the horizontal direction)	kNm	114,479
OM <sub>PV</sub> Forces (Thrust) (Overturning moment due to the photovoltaic panel wind thrust forces)	kNm	84,576
OM <sub>Structure</sub> Wind Drag (Overturning moment due to the structure wind drag)	kNm	39
OM <sub>Wave</sub> Thrust (Overturning moment due to the wave forces on the structure)	kNm	14,346
OM <sub>Total</sub> (Total overturning moment)	kNm	98,962
RM/ OM (Ratio of the righting moment of the overturning moment)	N/A	1.16

**Table (12):** Moment Forces for the Photovoltaic Installation in Survival Mode.

T <sub>ACTUAL</sub> (Tensile force used in the mooring line to counteract the overturning forces at a safety factor of 1.2)	kNm	1,350
RM <sub>LONGITUDINAL</sub> (Righting moment force in the horizontal Direction)	kNm	325,346
OM <sub>PV</sub> Forces (Thrust) (Overturning moment due to the photovoltaic panel wind thrust forces)	kNm	244,425
OM <sub>Structure</sub> Wind Drag (Overturning moment due to the structure wind drag)	kNm	113
OM <sub>Wave</sub> Thrust (Overturning moment due to the wave forces on the structure)	kNm	33,364
OM <sub>Total</sub> (Total overturning moment)	kNm	277,902
RM/ OM (Ratio of the righting moment of the overturning moment)	N/A	1.17

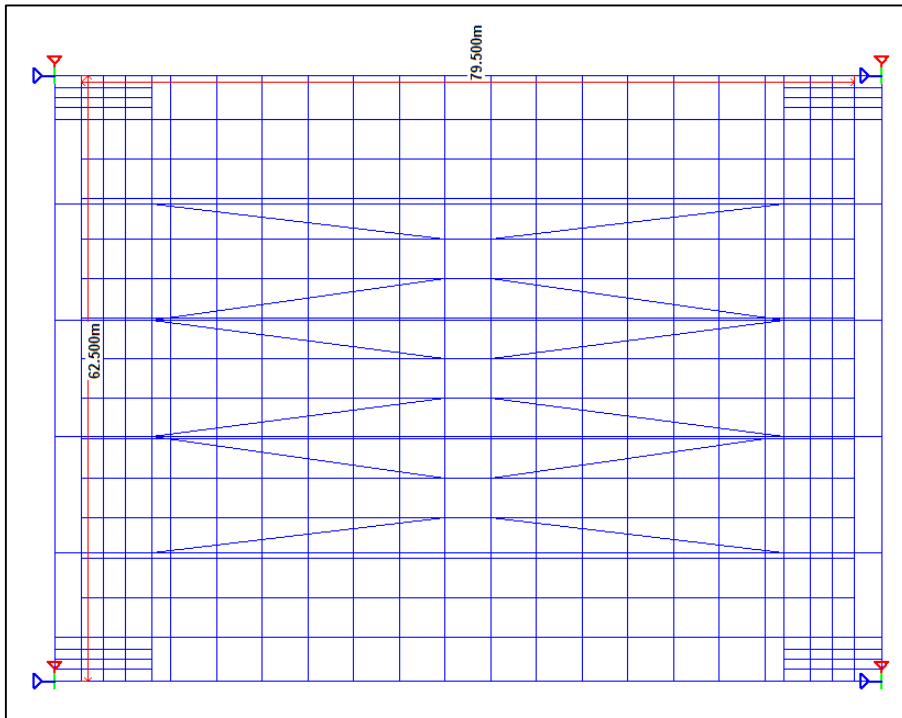

**Figure (7):** Truss Structure for the Photovoltaic Installat

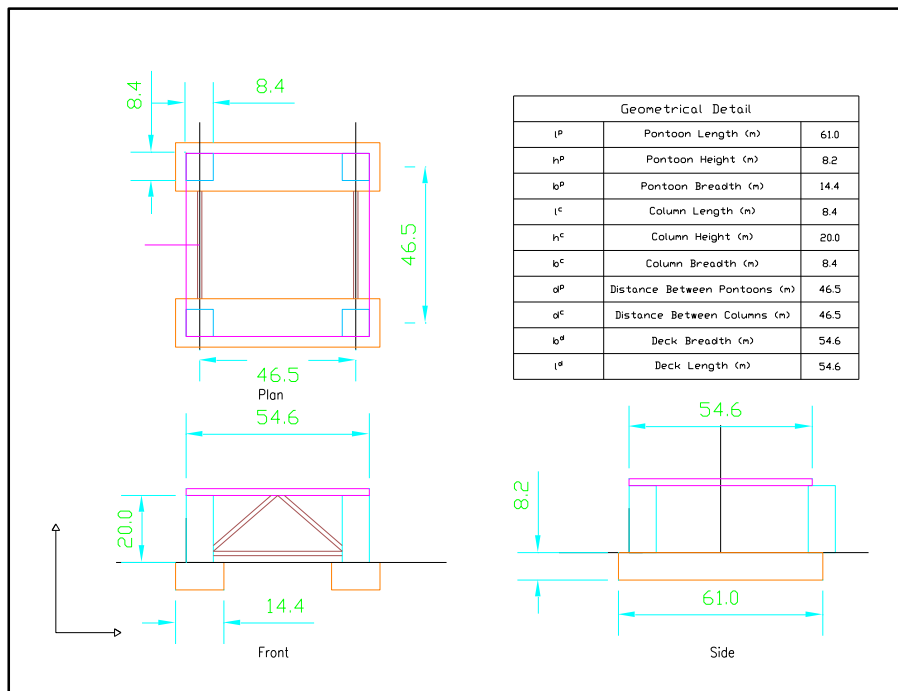

**Figure (8):** Wind Turbine Semi-Submersible Structure

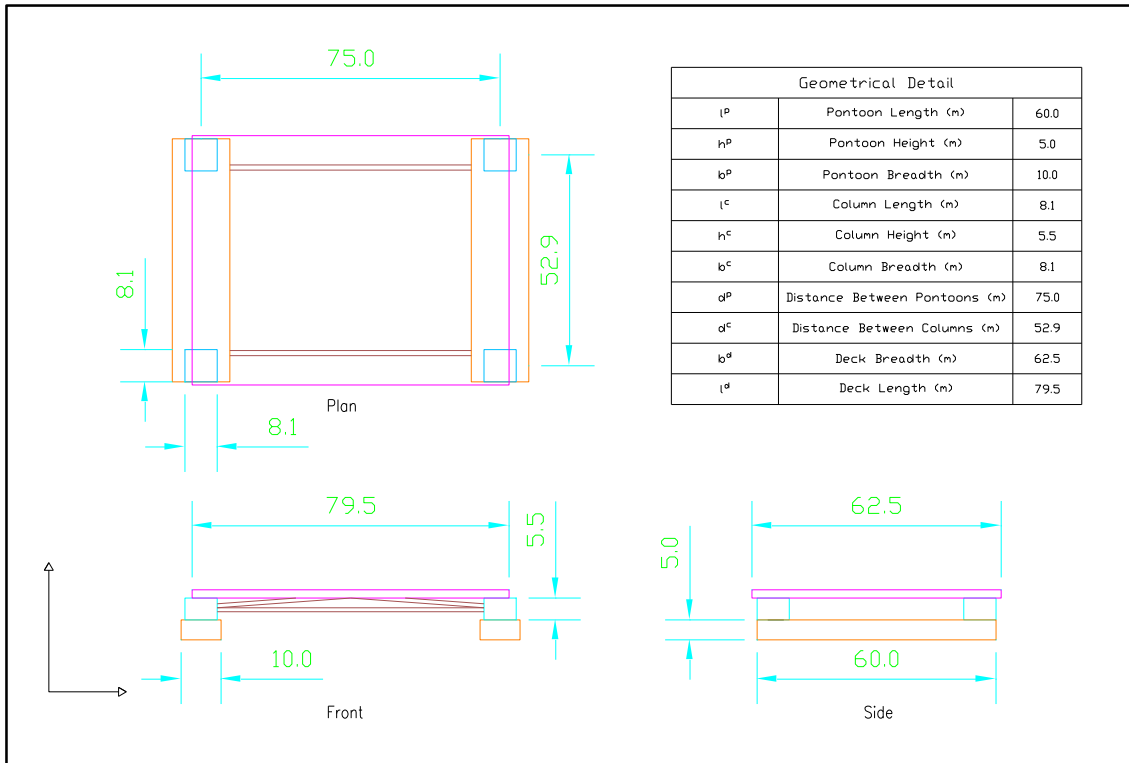

**Figure (9):** Photovoltaic Semi-Submersible Structure

As for the wind turbine scenario a static structural analysis was carried out using STAAD on a space truss supporting the photovoltaic installation as shown in Figure (7).

**Table (13):** Mooring Configuration for the Photovoltaic Installation.

Operational	Survival
Two 475 kN loaded mooring lines	Two 1,350 kN loaded mooring lines
Drag embedment anchors.	Drag embedment anchors.

The member type used is noted in Table (14) resulting in a total structure weight of 1,380 Tonnes. This compared reasonably well with the weight of 1,420 Tonnes as calculated through the iterative calculations of Microsoft Excel.

**Table (14):** Material Specifications – Photovoltaic Installation.

Pontoons/ Columns	Deck Beams	Deck Plates
HD360X196	IPE550	12 mm
718	284	378

Displacement and shear force and bending moment diagrams were set up in STAAD and in general there were no failures again using material properties as noted in Table (8) and considering default safety factors from EN 1993-1-1 of 1.4.

#### 4.4 Outcome of Design Characteristics

The primary objective of the work upon which this paper has been compiled was to compare floating offshore platforms carrying wind turbines with platforms designed to carry photovoltaic panels.

The hydrostatic pressure for both structures was calculated at the furthest depth, that being the calculated draft of each of the structures. The wind turbine thrust force using the BEM theory and the aerodynamic loading on the photovoltaic panels (based on BS 6399 [15]) were applied as an overturning moment in the respective structures.

The wind loading on each of the structures under both environmental conditions was worked out using the aerodynamic drag formula and applied as a nodal concentrated force acting at a high point in the structure providing an overturning moment whilst wave loading was calculated using Morrison's equations and applied also as an overturning moment [16].

The calculations for stability and geometrical dimensions were iterative using the Solver algorithm in Microsoft Excel. The software STAAD was used for a static analysis of each of the structures where beam failures under static loading were checked including deformations and force diagrams. The weight of the amount of steel used to set up the structure using STAAD was compared with thatThe heave, pitch and roll natural periods as obtained from the iterative calculations were determined as noted in the summary of Table (15). The value for “heave” for both floating structures is within the DVN standards <sup>[14]</sup> and lies well in the low energy region of the response amplitude operator for a typical floating structures <sup>[14]</sup>. The “pitch” and “roll” for the photovoltaic structure are somewhat shifted to the left of a typical response function and in agitated seas, the design may be problematic.

**Table (15):** RAO Indicators

	Heave	Pitch	Roll
WT Semi-Submersible	20.0	67.9	67.9
PV Semi-Submersible	23.6	27.8	27.8

The final hull design dimensions for the two installations are shown in Figures (7) and (8). The hull concept design having two pontoons supporting four columns, which in turn support a deck, was kept the same for both installations. This simplifies the analysis when one compares one energy platform with the other.

The analysis carried out in STAAD showed that the interface between the wind turbine base and the structure deck needs to be re-evaluated. The deflections for the photovoltaic installation structure are within reasonable limits and show that the design as input in STAAD could be a good starting point for further analysis.

Spread moorings were chosen for the two semi-submersibles for each of the operational and survival scenarios since the structures would be operating in the Mediterranean environment where sea and wind conditions are mild. The proposed design considered 250 mm chain moorings.

The total hull costs for each of the installations were approximated using top level costs to calculate the LCOE for each of the platforms as noted in Table (16). The study of these structures and the respective energy systems which are mounted on them is definitely an engineering challenge and one which

needs research, prototyping and further analysis to come up with the most cost effective solution. The dissertation upon which this paper has been written has touched on numerous aspects of the design process, each of which is a field of study in itself.

#### 4.5 Comparing Results with other Models

When reviewing and comparing existent floating designs for deep water semi-submersible structures it appears that the semi-submersible type is the most attractive option for floating wind power projects. Although TLPs offer a good degree of stability, the installation of the tethers often requires significant and invariably expensive seabed preparation. On the other hand, their principal advantage is the ease with which they can be installed. Stability is a challenge due to sway, pitch and rolling.

Prototypes to date show that a three column structure for offshore wind turbines is feasible and thus one can surmise that for commercialisation purposes, the cost of the structure for the wind turbine installation can be reduced even further.

The offshore structure concepts studied and proposed in this research are designed in the Olympian-scale tradition of the offshore oil and shipbuilding industries, given they have relatively big hulls when compared to the offshore semi-submersible wind turbine installation [17]. Table (16) shows a comparison between the two semi-submersible structures which have been proposed (as per the calculations carried out) and two types of semi-submersible structures which are at the opposed ends of the spectrum as far as size and geometrical configuration are concerned. The WindFloat design is a structure which in concept is very similar to that presented in this paper. As can be noted the structure weight is in line with that calculated, namely of the order of 2,500 T.

The analysis as presented here has shown that although a structure for the installation of an offshore wind turbine needs to be larger and more robust and necessitates the use of more steel and stronger sections due to the larger dead loads and larger environmental forces than a PV supporting one, the resultant energy generated outweighs the fabrication and installation costs. Overall, floating offshore wind energy appears to be more economically feasible than installing floating photovoltaic panels. Of course, as technology evolves and as the technologies become cheaper, this conclusion may need to be revisited. As things stand to date, this preliminary appraisal shows that

offshore wind farming gives a better financial return than offshore photovoltaic installations.

## 5 ECONOMIC CONSIDERATIONS

### 5.1 The Wind Turbine Platform

The estimated cost for the preliminary and geotechnical testing, including management and contingency fees, would be of the order €0.5 M [19]. The wind turbine and electrical costs have been estimated at €10.1 M [3], [8], [9]. This is a hypothetical cost based on a distance from shore of 5,000 m and an inshore cable distance of 2,000 m to the main electrical grid distribution centre that would take the power.

Materials have been based on a cost of steel of €0.524/kg [10] for the calculated structure weight of 2,810 T and an estimated 250 T of steel plates for the pontoons (steel plates for the pontoons were neither part of the Microsoft Excel calculations nor of the STAAD analysis. Hence, these are being added for the cost analysis).

Labour cost has been estimated for a work force of 30 workers at an average wage cost of €20/Hour. A generic estimate for the completion time would be that of a 24/7 operation for one year, namely 8,760 hours [11] or equivalent, depending on the available work force.

Should this offshore structure be built, then this would take place in the docks which are located just opposite the mooring area to the South East of the coast. The platform would then be towed out to the location using tugboats, be positioned and moored. The port and staging costs have been estimated at €5.3 M [3] [8] [9].

O&M costs have been estimated at €2.1 M on an annual basis [8] [9].

Summing up the CAPEX and OPEX costs and equating to the total energy generated, the levelised cost of energy works out at €0.24/ kWh using a discount rate of 10%.

### 5.2 The Photovoltaic Platform

The rate for the preliminary and geotechnical testing, including management and contingency fees, has been taken similar to that noted for the wind turbine installation at an estimated cost of €0.84 M.

The photovoltaic panels and BOS costs have been estimated at €10.1 M with the assumption that the

panels would be purchased at €0.56/Wp. Installation rates for the electrical equipment have been assumed similar to those of the wind turbine installation.

Materials required for a calculated structure weight of 1,243 T and an estimated 250 T of steel plates for the pontoons for all of the 18 photovoltaic installations (amounting to 8,500 kWp) were costed at €5.7 M. As for the wind turbine structure, should these offshore structures be built, then this would happen in the docks, followed by towing and mooring at the intended location. This cost, including mooring equipment costs, has been estimated to be €9 M [12] [13]. O&M costs have been estimated at €3.6 M [8] [9].

Thus summing up the CAPEX and OPEX costs, the levelised cost of energy is €0.38/kWh at a discount rate of 10 %.

## 6. CONCLUSIONS

Achieving a stable and affordable energy supply to a small island country is always a challenge. Being a densely populated island nation with high energy demand and limited land area, Malta may need to turn to the sea for alternatives. Just as research on land-based wind and photovoltaic installations continues, attention is turning towards offshore renewable energy opportunities. Within the options of photovoltaic installations, including roof and ground based setups, offshore solutions are being researched. One of the main concerns for floating deep water installations is that of being an unproven technology lacking extensive testing in the case of wind installations and very little testing, if at all, for photovoltaic installations in an offshore environment. When considering such offshore installations, an engineering challenge lies in the type of supporting structure to be used. New designs for a deep water supporting structures for offshore wind turbines at 70 metres depth, optimised for Mediterranean weather conditions, are being studied by various companies and countries at the time of writing.

As for all commercial projects, the economic drivers enable the stakeholders to make their decisions. And thus, to the crucial question and objective of this dissertation: Would an investor put his money in a local floating offshore photovoltaic installation or in an offshore wind farm? This paper has given good indications that the financial returns could be much better off if one were to invest in the development of a deep offshore floating wind turbine.

**Table (16):** Material Specifications – Photovoltaic Installation.

	Wind Turbine Semi-Submersible	Photovoltaic Semi-Submersible	WindFloat [20] Semi-Submersible	Hexicon [21] Semi-Submersible
GPS Latitude	35.83	35.83	41.43	36.87
Sea Name	Mediterranean Sea	Mediterranean Sea	Atlantic Ocean	Mediterranean Sea
Floating Depth (m)	60 - 100	60 - 100	52 – 53	40 - 70
Overall Size (m)	59.00 X 52.00	62.50 X 79.50	40 m high columns and a height of 22.2 m from tower to support structure footage.	Hull of 480 metres across and 26 metres tall in the water with a draught of 18 metres.
Pontoon Length (m)	59.13	60.00		
Pontoon Width (m)	14.60	9.97		
Pontoon Height (m)	8.00	5.00		
Column Length (m)	7.71	4.50		
Column Width (m)	7.71	4.50		
Column Height (m)	20.27	5.50		
Draft (m)	16.90	9.38		
Air Gap (m)	11.40	1.10		
Displacement (MT)	16,648.00	6,857.20		
Hull Weight (MT)	3,049.00	1,493	< 2500	23,000
Ballast Weight (MT)	13,695.00	5,667.6	Unknown	Unknown
CAPEX (€)	19,229,668.00	25,652,435.80	Unknown	Unknown
OPEX (€)	2,093,525.00	3,558,992.5	Unknown	Unknown
LCOE (€/ kWh)	0.24	0.38	Unknown	Unknown

**REFERENCES**

- [1] Microsoft Corporation: Microsoft Excel 2013
- [2] Available online at: <http://www.bentley.com/en-US/Products/STAAD.Pro/> (Accessed in: October 2014).
- [3] Available online at: <http://en.wikipedia.org/> (Accessed in July 2014).
- [4] Available online at: [http://en.wikipedia.org/wiki/List\\_of\\_offshore\\_wind\\_farms](http://en.wikipedia.org/wiki/List_of_offshore_wind_farms) (Accessed in: July 2014)
- [5] J. R. Gallala, Hull Dimensions of a Semi-Submersible Rig, June 2013. Available online at: <http://urn.kb.se/resolve?urn=urn:nbn:no:ntnu:diva-22536> (Accessed in July 2014).
- [6] Available online at: <http://www.capemalta.net/maria/pages/about.html> (Accessed in July 2014).
- [7] Available online at: [www.solsticeenergy.co.uk](http://www.solsticeenergy.co.uk) (Accessed in: October 2014).
- [8] L. Fenech, Design and Cost Evaluation of a Deep Water Support Structure for an Offshore Wind Turbine in Maltese Conditions, M.Sc. in Engineering, Dept. of Mechanical Engineering, University of Malta, Msida, Malta, 2011.
- [9] B. Maples, G. Saur, and M. Hand, National Renewable Energy Laboratory, R. van de Pietermen and T. Obdam, Installation, Operation, and Maintenance Strategies to Reduce the Cost of Offshore Wind Energy Technical Report, NREL/TP-5000-57403 (July 2013)
- [10] Available online at: <http://www.rukki.com> (Accessed in October 2014)
- [11] Siemens. Available online at: <http://www.siemens.com/wind> (Accessed in October 2014)
- [12] A market approach for valuing solar PV Farm assets, Deloitte, April 2014.
- [13] Levelised Cost of Electricity Renewable Energy Technologies, Fraunhofer ISE, November 2013.
- [14] DNV-RP-F205, Global Performance Analysis of Deepwater Floating Structures, October 2010.
- [15] BS 6399 Part 2: Wind Loads, BSI, UK, October 1998.
- [16] O. M. Faltinsen, Sea Loads on Ships and Offshore Structures, Cambridge University Press, U.K., 1993.
- [17] Floating Offshore Wind Foundations: Industry Consortia and Projects in the United States, Europe and Japan, Maine International Consulting LLC, USA, September 2012.
- [18] J. Yonkman, S. Butterfield, W. Musial and G. Scott, Definition of a 5-MW Reference Wind Turbine for Offshore System Development Technical Report. NREL/TP-500-38060. February 2009
- [19] B. Maples, G. Saur, and M. Hand, National Renewable Energy Laboratory, R. van de Pietermen and T. Obdam, Installation, Operation, and Maintenance Strategies to Reduce the Cost of Offshore Wind Energy

Technical Report. NREL/TP-5000-57403. July 2013.

[20][Online]. Available:  
<http://www.lorc.dk/offshore-wind-farms-map/windfloat-demonstration> (December 2014)

[21][Online]. Available:  
<http://www.4coffshore.com/windfarms/hexicon---peloponnese-greece-gr58.html> (December 2014)