

Open Research Online

The Open University's repository of research publications and other research outputs

Technological development of the OGRE focal plane array

Conference or Workshop Item

How to cite:

Tutt, James; McEntaffer, Randall L.; DeRoo, Casey; Schultz, Ted; Rogers, Thomas; Murray, Neil; Holland, Andrew; Weatherill, Daniel; Holland, Karen; Colebrook, David and Farn, David (2015). Technological development of the OGRE focal plane array. In: UV, X-Ray, and Gamma-Ray Space Instrumentation for Astronomy XIX, article no. 960105.

For guidance on citations see [FAQs](#).

© 2015 Society of Photo-Optical Instrumentation Engineers (SPIE)

Version: Version of Record

Link(s) to article on publisher's website:
<http://dx.doi.org/doi:10.1117/12.2186630>

Copyright and Moral Rights for the articles on this site are retained by the individual authors and/or other copyright owners. For more information on Open Research Online's data [policy](#) on reuse of materials please consult the policies page.

oro.open.ac.uk

Technological developments of the OGRE focal plane array

James H. Tutt^a, Randall L. McEntaffer^a, Casey DeRoo^a, Ted Schultz^a, Thomas Rogers^b, Neil Murray^c, Andrew Holland^c, Daniel Weatherill^c, Karen Holland^d, David Colebrook^d and David Farn^d

^aUniversity of Iowa, Van Allen Hall, Iowa City, IA, USA;

^bCASA, University of Colorado, Boulder, CO, USA;

^cCentre for Electronic Imaging, The Open University, Walton Hall, Milton Keynes, UK;

^dXCAM Ltd, Round Spinney Industrial Estate, Northampton, UK

ABSTRACT

The Off-plane Grating Rocket Experiment (OGRE) is a high resolution soft X-ray spectrometer sub-orbital rocket payload designed as a technology development platform for three low Technology Readiness Level (TRL) components. The incident photons will be focused using a light-weight, high resolution, single-crystal silicon optic. They are then dispersed conically according to wavelength by an array of off-plane gratings before being detected in a focal plane camera comprised of four Electron Multiplying Charge-Coupled Devices (EM-CCDs). While CCDs have been extensively used in space applications; EM-CCDs are seldom used in this environment and even more rarely for X-ray photon counting applications, making them a potential technology risk for larger scale X-ray observatories. This paper will discuss the reasons behind choosing EM-CCDs for the focal plane detector and the developments that have been recently made in the prototype camera electronics and thermal control system.

Keywords: Sub-orbital rocket, Sounding rocket, OGRE, Spectrometer, X-ray, EM-CCD

1 Introduction

Instruments that provide high resolution soft X-ray spectroscopy are desirable in astronomy as they are able to provide detailed information of the structure of warm/hot regions of the Universe, such as supernova remnants and black hole accretion disks. Better understanding of these regions will lead to development of models and theories that better explain the formation and evolution of the Universe. In particular, high resolution soft X-ray spectroscopy will allow the theory that half of the missing baryonic content of the Universe currently resides in thin filaments between galaxies known as the Warm-Hot Intergalactic Medium (WHIM) to be examined^{1,2}

Surveys of energy and matter in the Universe fail to account for half of the baryonic matter thought to exist under the standard cold dark matter model. This has led to the theory that the missing matter resides in the voids between galaxies in thin filamentary structures known as the WHIM, also often referred to as 'the cosmic web'.³ Due to this filamentary structure, it is not possible to detect WHIM material in emission; therefore, attempts to locate the matter rely on observing its absorption features in a bright X-ray background. The observation of the WHIM requires an instrument that is able to resolve the faint absorption features that will be present in the X-ray spectrum from a bright, distant source, such as a high z -AGN. Such an instrument will require a large effective area, long observation times and a resolving power of greater than 2000. These absorption features should occur in the 200 eV to 1000 eV X-ray band.

OGRE, due for launch in 2018 from the Poker Flats Research Range in Alaska, represents a significant step along the road to the development of such an instrument. Due to the nature of sounding rocket flights, OGRE will not have a large enough effective area or observation time to be able to detect the WHIM. However, OGRE will act as a demonstration that the desired resolving power can be achieved using this style of instrument. Also, due to its modular design, the OGRE spectrometer is easily scalable to allow for future large effective area

Further author information: (Send correspondence to James H. Tutt)
James H. Tutt: E-mail: james-tutt@uiowa.edu, Telephone: 1 319 335 1835

versions to be flow based on OGRE heritage. To demonstrate this high resolution performance across the 200 eV to 1000 eV energy range, OGRE's target will be a well known, bright X-ray source, Capella.

This paper will focus on the focal plane of OGRE, as the use of EM-CCDs for soft X-ray detection is unusual. Through the course of describing how the development of such a focal plane camera will occur, the reasons for the choice of using EM-CCD instead of more conventional CCDs will be discussed, allowing the reader to understand the advantages that EM-CCDs offer to soft X-ray spectrometers.

2 OGRE focal plane

The OGRE focal plane detector is required to be able to determine the location to which a photon is dispersed by the off-plane grating module. To determine the photon wavelength with high resolution, a camera with high spatial resolution is required.^{4,5} To determine its wavelength with a high resolution, requiring a camera with high spatial resolution. Also, as off-plane gratings can disperse X-rays of different energy and order to the same point on the focal plane, the camera requires a good enough energy resolution to enable order separation.^{6,7,8}

OGRE is designed to detect low energy X-rays in a photon starved environment; therefore, any increase in the signal-to-noise ratio of the incident photons aid in their detection and signal processing, which can be achieved through the increase in the signal in a pixel before it is read out in an EM-CCD.⁹ The e2v CCD207-40¹⁰ is the detector that has been chosen for the OGRE focal plane (Figure 1).

The CCD207-40 is a large format (26.11 mm x 25.73 mm) EM-CCD that has small pixels (16 μm) to allow for good spatial resolution. The detector is designed with two output nodes. By reading the serial register elements from left to right in Figure 1, the charge accumulated in the silicon is read through the High Responsivity (HR) output node. The HR node is designed as a low noise output, identical to what would be found on a conventional CCD, allowing the CCD207-40 to be read out as through it did not have a multiplication gain capability. Through reading the serial register elements out right to left in Figure 1, the charge in the elements goes through the multiplication register allowing the number of electrons in each element to be increased before being read out from the Large Signal (LS) output node. The LS node is designed to accommodate large signals; therefore, it has a large size and a large capacitance. This causes the LS output node to be higher noise than the HR output node, but this noise is effectively suppressed by the multiplication gain.

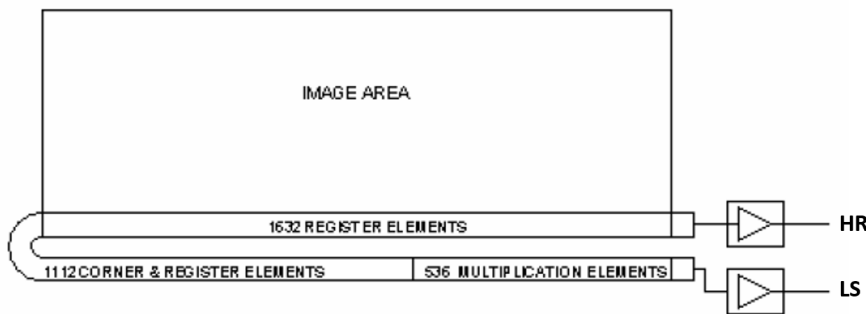

Figure 1. Schematic of the e2v CCD207-40. The device is a full-frame 1632 pixel x 1608 pixel detector with 16 μm pixels. The output register comprises of the standard 1632 element serial register, but with the addition of 1112 corner and register elements and a multiplication register that is 536 elements long. The device can be readout through the multiplication register to the Large Signal (LS) output node or backwards through a High Responsivity (HR) output node.¹⁰

Multiplication gain is highly temperature dependent and more effective at lower temperatures.¹¹ Lower temperatures are also used in EM-CCDs as a method to suppress dark current. For these reasons, the focal plane camera on OGRE is going to be cooled using Liquid Nitrogen (LN2). An initial design of the camera for the focal plane is shown in Figure 2.

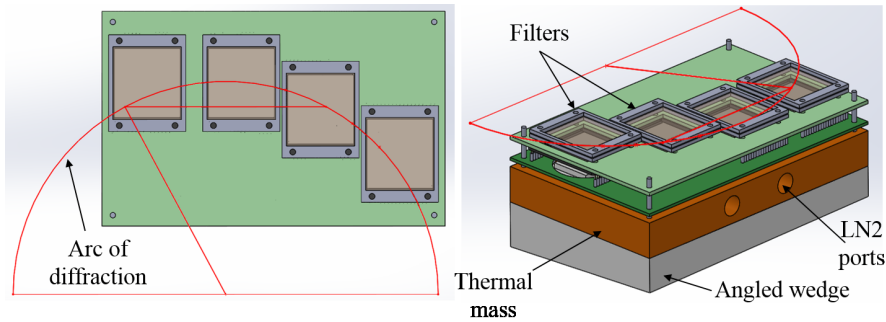

Figure 2. Preliminary design of the OGRE focal plane. The CAD model shows the CCDs mounted onto TEC controllers that are in thermal contact with a LN2 cooled copper thermal mass. The CCDs are staggered to enable a large portion of the arc of diffraction to be detected and the whole assembly is centered on an angled wedge to better match the focal plane to the focus of the optic. The CCDs are covered by thin Al optical blocking filters.

The EM-CCDs are mounted side-by-side in an arc that matches the arc of diffraction generated by the focusing optic and the off-plane grating module. The headboard that the CCDs are mounted into is the conduit that brings the bias and clock potentials onto the detectors and takes the signal from the output node to the processing electronics. The detectors are resting on Thermal Electric Coolers (TEC) that use current to generate a thermal gradient, taking heat from the EM-CCDs and releasing it into the large thermal mass. The amount of cooling that the TECs can provide is determined by how cold the thermal mass can be made. The thermal mass is made from copper and cooled using LN2, allowing temperatures below $-100\text{ }^{\circ}\text{C}$ to be achieved. OGRE will not be flown with a supply of LN2; therefore, the thermal mass of the copper block has to be large enough to allow the EM-CCDs to be held at a constant temperature throughout the flight. Variations in temperature will cause a variation in the level of multiplication gain achieved. At one hour prior to launch, the LN2 umbilical on OGRE will be removed.¹¹ The EM-CCDs will be held at a temperature above the maximum cooling temperature the thermal mass could provide ($-80\text{ }^{\circ}\text{C}$) giving a margin in the cooling potential that can be used to hold the detectors at a constant temperature using the TECs.

The EM-CCDs are being held at cryo-temperatures for a long period of time before launch; therefore, they will also need to be under vacuum. To achieve this, a commercially available vacuum door will be placed on the electronics deck (E-deck) bulk head on OGRE. The door will maintain the vacuum in the focal plane camera chamber, together with an ion pump, until OGRE is ready to begin observation. Once at altitude, the door will open, exposing the camera to space. After the observation the door will close protecting the camera during re-entry (Figure 3).

The thermal mass is mounted on an angled wedge that canters the focal plane at an angle allowing it to better match the focal plane created by the focusing optics and gratings that is predicted through ray-tracing of the optical path.¹² This is still an approximation to the true focus; however, the depth of focus of the instrument is large enough that no significant aberration of the spectra will be caused by this approximation.

Capella is an optically bright source; therefore, as EM-CCDs are effective detectors of optical photons, Al optical blocking filters are required. The filtering strategy for each detectors used is dependent on the location along the arc of diffraction that the device is placed. The spectral EM-CCDs (the three furthest along the arc in Figure 2) require filters that are thick enough block any stray optical light, but are thin enough to be transmissive to incident X-rays so that just the X-ray signal is measured. The zero-order EM-CCD will have optical light from Capella focused onto it by the telescope optics, leading to a higher optical flux on this detector compared with the other three. The X-ray flux from Capella in zero-order is expected to be low and good knowledge of the zero-order focus is required to determine the wavelength of the diffracted orders. By using the focused optical light, it should be possible to calibrate the arc of diffraction to a high level of accuracy without relying on the few X-ray photons. The zero-order detector Al optical filter will have to be carefully chosen to allow enough optical photons through to calibrate the arc of diffraction without swamping the detector or readout electronics. Filtering for the detectors will require further study before the launch of OGRE.

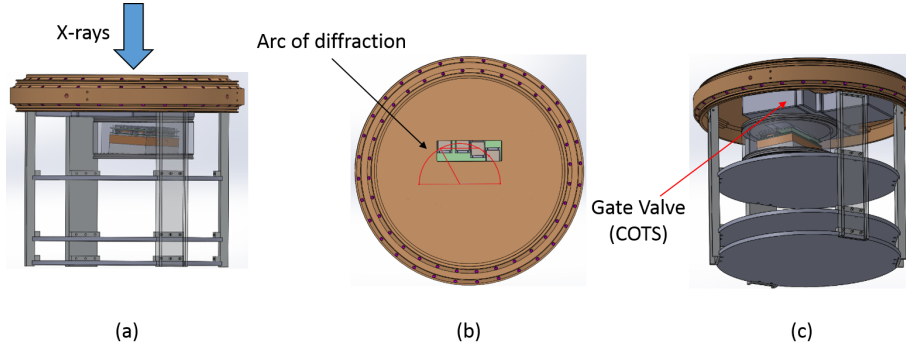

Figure 3. CAD of OGRE’s E-deck. The X-rays are incident onto the focal plane camera, that is contained within a vacuum chamber, through a hole in the E-deck bulkhead and a gate valve. The location of the chamber on the E-deck bulkhead is shown in (a), the hole in the E-deck is shown in (b) and the gate valve location is shown in (c). The gate valve is required to protect the cold EM-CCDs from atmospheric contamination while on the ground and re-entry after the observation.

The EM-CCDs being used on OGRE are commercially available detectors in e2v’s standard ceramic packages. The devices are not two side butttable; therefore, the minimum dead space between the active silicon of one device and the active silicon of the adjacent device is ~ 11 mm. The spectrum from Capella is well known with the brightest lines being expected at 15.013 Å, 17.071 Å and 17.119 Å (Fe XVII) and 18.967 Å (O VIII).¹³ The optics of OGRE will have to be designed in such a way that these target lines do not fall in the gaps between the devices, which places a restriction on the optical path of OGRE.

3 Camera system

The entire rocket payload will be operated using a 28 V battery and all other potentials will be generated from this using level translators. The 28 V bus potential will be routed to the headboard of the CCD electronics. When there it will be level translated to 5 V to provide power to the four BeagleBone Blacks (BBB), temperature controller interface, serial interface and CCD sequencer. The 28 V bus will also be level translated into the potentials required for the bias and clock potentials required to operated the CCDs and for the operating of the pre-amplifiers and Analogue-to-Digital Converters (ADCs) on the headboard. The multiplication register on the EM-CCDs will require a high voltage input (~ 40 V) that will need to be constant throughout the flight to maintain a constant gain level. The rocket battery is expected to show some degradation over the course of the flight; therefore, the final electronics will have to be designed to account for such a degradation.

The CCDs are all read out using the same sequencer, controlled by the headboard, at a frame rate of 1 Hz (900 ms integration time and 100 ms read time). To enable such a fast read-time, the pixels are clocked at 1 MHz, the image area is binned 10 times in the parallel direction and half of the image area is dumped into the dump drain through the dump gate. The data is amplified by the pre-amplifiers on the headboard (with a gain of 10x), before being converted into a digital signal and serialized for transmission to the BBBs on the motherboard. The BBBs take each full-frame from the CCDs, store it in on-board memory and search the image for X-ray events. Each event found will be analyzed to discover if the charge is split across multiple pixels. All of the charge from the X-ray photon will be combined into the central pixel and the x-position, y-position and signal level will be recorded. This information will be stored in the BBBs FIFO waiting for a signal from the NASA telemetry stack. When called for, the data in the FIFO will be transmitted to the telemetry stack, compiled into a serial data-stream and telemetered to the ground.¹⁴ This allows for real-time monitoring of the rocket payload and protects against losing the rocket data if the payload is never recovered. Currently, it is expected that each of the detectors will telemeter its data in a separate, parallel data-stream. The basic operation of the CCD electronics is shown in the schematic in Figure 4.

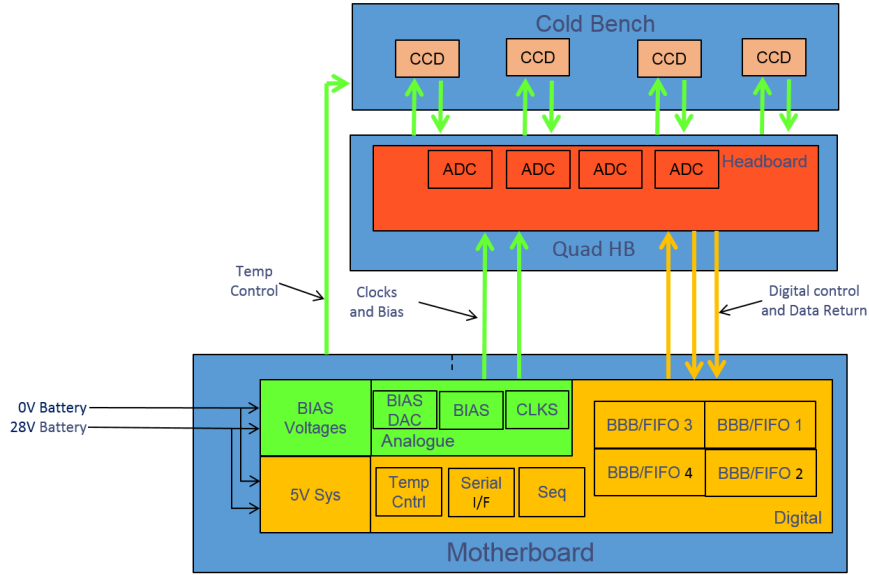

Figure 4. Schematic of the camera system for OGRE. The camera system is divided into three components. The cold bench houses and cools the four CCDs. The quad headboard houses the pre-amplifiers, ADCs and low pass filters for the clocks and bias potentials. The Motherboard houses the BBBs (used for image storage, signal processing and data buffering), temperature control, serial interface, CCD sequencer and level translators to convert bus potential to required levels.

4 EM-CCDs

An EM-CCD operates in the same way as a conventional CCD, but a multiplication register is added to the structure at the end of the serial register. By accelerating the electrons in the charge packet through an area of high potential, there is a small probability that each electron will ionise an additional electron from the silicon lattice in a process known as impact ionisation.¹¹ This impact ionisation increasing the number of electrons in the charge packet and leads to an increase in signal. This process is repeated through many multiplication elements (536 in the CCD207-40) leading to a potentially very large increase in the signal.⁹ The noise floor of a camera array is dependent on the read noise when converting the charge in the pixel into a voltage at the output node. An increase in signal through multiplication gain in an EM-CCD is equivalent to a reduction in the read noise of the output node and can allow EM-CCDs to be readout with sub-electron equivalent readout noise (rms).

The use of multiplication gain does cause an increase in the noise related to the size of the signal generated by the photon interaction in the silicon. As impact ionisation is a stochastic process, an additional component of shot noise is added to the system. This noise has been quantified as the excess noise factor¹⁵ for optical photon detection and the modified Fano factor when detecting X-rays.^{16,17} It causes a degradation of the spectral resolving power of the camera. It is important that this degradation of spectral resolution does not increase to a level where the detector can no longer be used to separate overlapping orders. It has been shown in previous papers that, at the photon energies that we are interested in, the degradation is small enough that overlapping orders can still be distinguish from one-another.^{6,7,8}

5 Camera prototype

The camera development for OGRE will occur in three phases. The prototype camera, which has already been developed, will be based around commercially available CCD97-10s.¹⁸ The CCD97-10 is a smaller active area device than the CCD207-40 that will be used on OGRE and it is frame transfer compared to the full-frame structure of the CCD207-40.¹⁰ Despite this, the small CCD97-10 shares clocking and sequencing characteristics

with the larger CCD207-40 and so serves as an ideal testing device. This phase also includes the breadboard development of proximity electronics and the initial BBB circuits.

The second phase of prototyping involves constructing a development model of the OGRE camera electronics. This phase is nearing completion with the design and build of a PCB motherboard to generate the required bias potentials, clocks, serial interface, temperature control and BBB interface. Proximity electronics have also been designed on PCB to house the pre-amplifiers for the detected signals, low pass filters on the bias lines and data serialisation. In this phase CCD207-10s (smaller versions of the final EM-CCDs) will be cryogenically tested at close to OGRE operation temperatures (~ 60 °C).

After extensive testing of the development model electronics, initially with CCD207-10s and then with flight like CCD207-40s, the flight model electronics will be developed, together with complete CAD models. This will aid integration of the camera onto the rocket payload. The final flight model will also have to be ruggedized for operation in a space environment. This will involve the use of arathane on any component that will fail in a vacuum environment or that is likely to outgass.

5.1 Prototype electronics

The prototype electronics was developed using standard XCAM Ltd. electronics with a breadboard BBB interface and some basic CCD proximity electronics (including pre-amp and ADC), Figure 5.

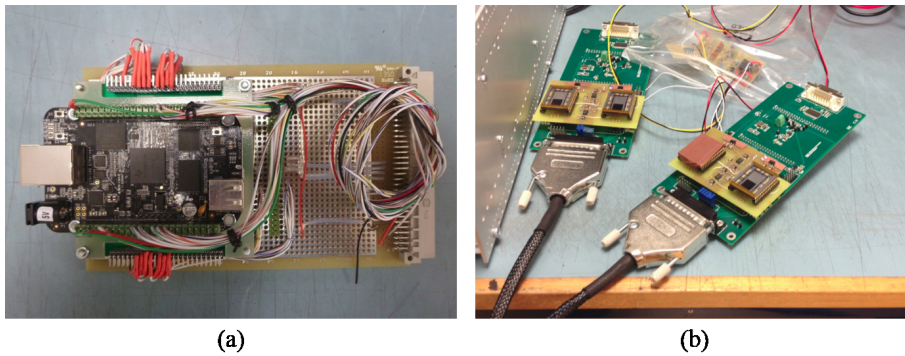

Figure 5. The camera prototype electronics. Photo (a) shows the breadboard design for the BBB interface and photo (b) shows the initial proximity electronics for providing bias potentials, clocks, pre-amplifiers and ADCs to the four CCD97-10s.

To test the electronics, the CCD97-10 detectors were operated warm, whilst being exposed to a flat field optical background and reading out the whole device, including the multiplication register and the image and stores sections (Figure 6). The dark portion on the left-hand side of the image is generated from the readout of the multiplication register (serial prescan). The speed at which these serial registers are read does not allow the significant accumulation of dark current leading to the low signal level seen. The bright section on the right-hand side of the image is caused by the readout from the image and store sections of the image. The store section is covered in a Al shield; therefore, all signal generation is from dark current which causes the middle shade of grey in the image. The brightest section is from the image section of the device that is exposed to optical photons. Regions of parallel overscan (at the top of the image) and serial overscan (at the right-hand edge of the image) are caused by reading additional rows and columns respectively than those physically present in the device.

The prototype electronics allowed the basic principles in the OGRE focal plane camera to be tested before moving onto more expensive, but more flight-like, electronics and detectors.

5.2 Development model electronics

The development model electronics was based around e2v CCD207-10s. The first step of the development was to design and manufacture electronics that were a close approximation to the final flight design and could be

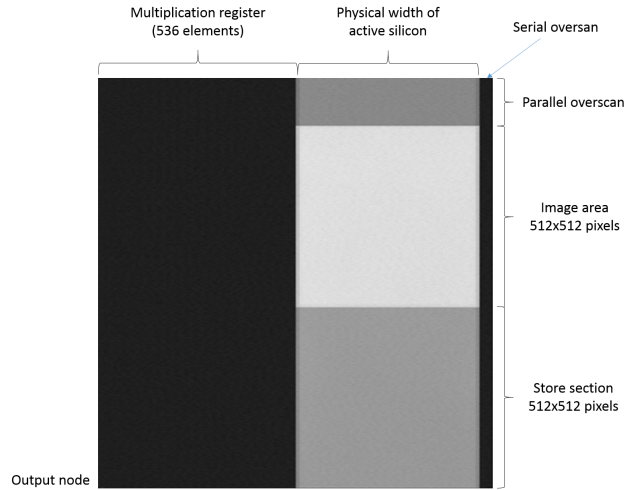
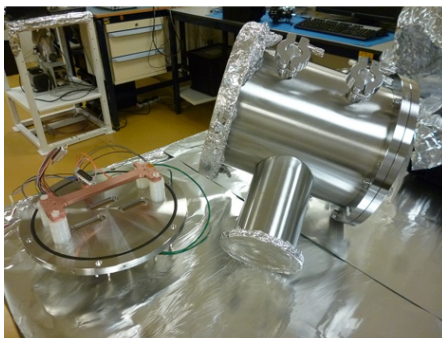
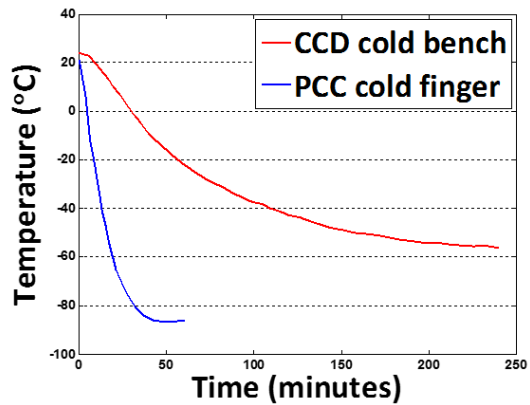

Figure 6. Full image taken using a CCD97-10 on the prototype electronics. There are many serial prescan elements due to the multiplication register (536 elements). The image and stored section are shown, with the image section appearing brighter than the store section. The detector was being illuminated at room temperature with a diffuse light source. The output node for this image is in the bottom left corner.



(a)



(b)

Figure 7. The chamber designed to house the the EM-CCDs, together with CryoTiger port and copper cold bench is shown in (a). The cool-down curves for the PCC cold finger and CCD cold bench are shown in (b) with the CCD cold bench reaching a temperature of -60 °C.

easily adapted to test both the CCD207-10 and the larger CCD207-40. An appropriate testing chamber was also designed to allow the testing of the detectors in vacuum and cold 7(a).

The cooling of the detectors was performed using a CryoTiger head in conjunction with a Brookes Poly-Cold Compressor (PCC). The CryoTiger head was connected, via copper braid, to a temperature controlled copper cold bench that directly cooled the detectors. The initial cool-down test, completed using a low grade PCC gas mixture produced the results shown in Figure 7(b). The temperature of the PCC cold finger and the CCD cold bench were monitored over time and it was found that the CCD cold bench could reach a temperature of -60 °C. The limit of this cooling potential was the grade of gas used in the PPC and the thermal conductivity of the braids. These aspects will be improved in future tests and are not relevant problems for the rocket payload as it will be using LN2.

With the EM-CCDs cooled to -60°C , they were illuminated with Mn K-alpha X-rays using an ^{55}Fe X-ray source. The level of multiplication gain provided by the multiplication register is determined by the potential on the $R\phi 2\text{HV}$ gate on the device.⁹ By increasing this potential, the level of multiplication gain will increase. Through taking multiple images at different $R\phi 2\text{HV}$ levels, a gain calibration could be made together with a measure of the suppression of the readout noise (also known as equivalent readout noise). This result can be seen in Figure 8. With 20 V on $R\phi 2\text{HV}$, the EM-CCD has unity gain and so is operating like a normal CCD, but through the LS output node; therefore it has a high readout noise (>100 electrons r.m.s.). As $R\phi 2\text{HV}$ increases, the gain of the multiplication register increases, which leads to a relative drop in the equivalent readout noise of the device due to the multiplication gain suppressing the readout noise. At a $R\phi 2\text{HV}$ potential of ~ 37 V the equivalent readout noise reaches sub-electron levels due to the gain rising to above 100.

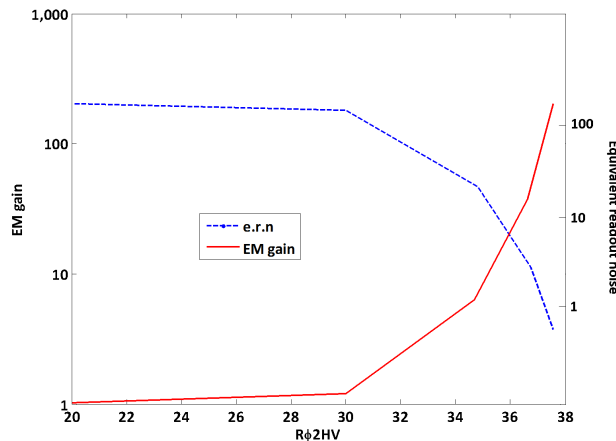

Figure 8. A plot showing the correlation between $R\phi 2\text{HV}$ potential, EM gain and equivalent readout noise. With unity gain, the equivalent readout noise of the camera is greater than 100 electrons (r.m.s.). As the potential on $R\phi 2\text{HV}$ increases, the amount of EM gain increases which suppresses the equivalent readout noise. At a potential of ~ 37 V the camera has an equivalent readout noise that is at sub-electron levels (r.m.s).

As the gain is increased, so can the level of signals in the multiplication elements increase. Such high signal levels have an increased probability of coming into contact with the surface states (dangling bonds) under the $R2\text{HV}$ electrodes and filling a continuum of trap energy levels up to the Fermi-level. These can then release trapped electrons over a range of times and manifest as the charge tails (or persistence) as seen in the lower example in Figure 9.

With $R2\text{HV}$ at 36.3 V the resultant multiplication charge packets generated by X-ray events are sufficiently small in size not to contact the surface during charge transfer, however, when $R2\text{HV}$ is equal to 37.5 V, the charge volume can contact the surface and forming a smear or tail pattern in the image. This smear is always following the charge packet.

Knowing at what level this smearing starts to happen allows an upper maximum to be set on the $R2\text{HV}$ potential; however, this image was taken with Mn K-alpha X-rays at 5898 eV. On OGRE the X-rays will be at least 6 times less energetic; hence, will generate 6 times less charge in the potential well of the multiplication register. This gain calibration will have to be completed again using the flight EM-CCDs, X-rays of the correct energy and at the flight operating temperature. Due to the close dependence on temperature that EM-CCDs show, the temperature of OGRE will be closely monitored and an X-ray calibration source will also be flown to keep track of any gain variations during flight.

To enable this testing to occur, development model electronics were designed and constructed. These electronics differ from the prototype electronics as they are fully incorporated onto PCB boards and are connected with vacuum compatible cables. The difference between the development model electronics and final flight elec-

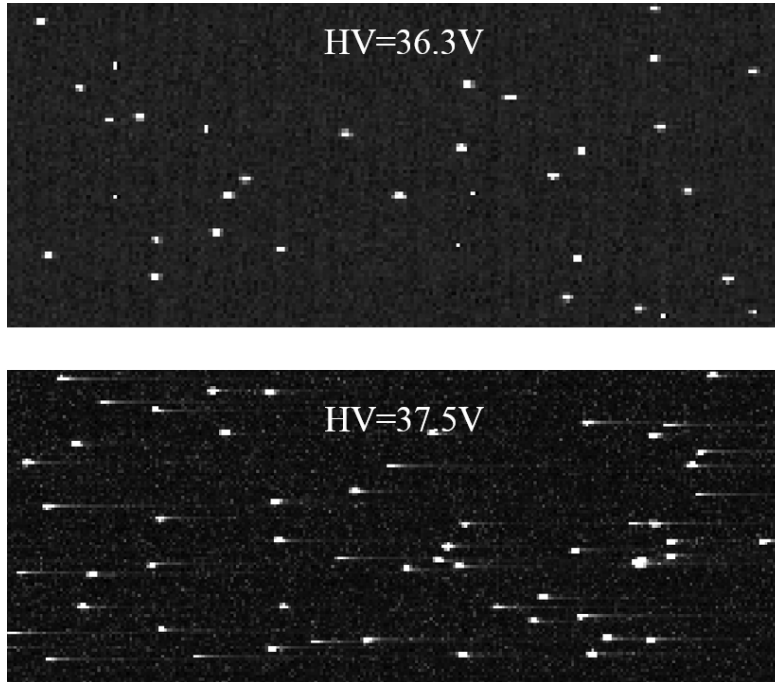

Figure 9. X-ray images being detected in a CCD207-10 with a HV level of 36.3 V and 37.6 V (corresponding to a gain of 30x and 200x respectively). The events that have been gained by 30x are well contained by the potential structure in the multiplication register; however, the events that have been gained by 200x exceed the full-well capacity of the multiplication register and demonstrate classic surface full well tails.

tronics should be small, providing the electronics perform well in long-term testing. The development model electronics is shown in Figure 10.

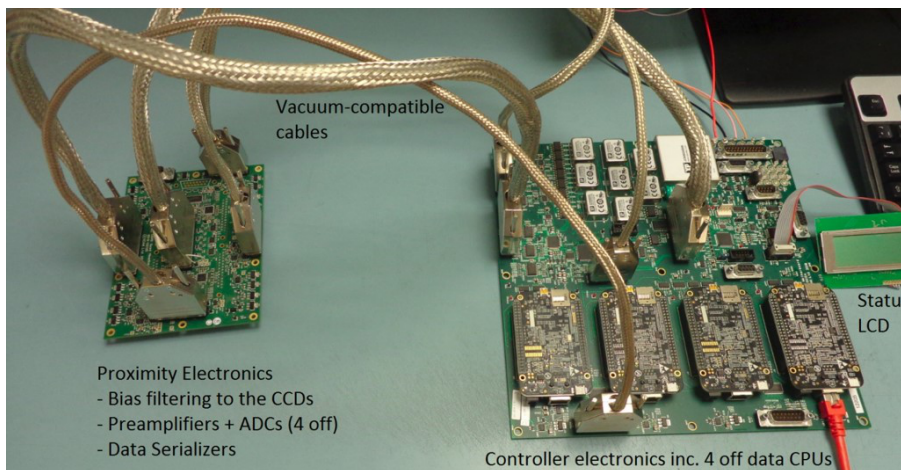

Figure 10. The development model electronics. The motherboard on the right shows four BBBs incorporated onto the board. The proximity electronics on the left is connected to the motherboard via four vacuum compatible cables. The motherboard includes a status LCD screen for user information.

There is some concern that the camera will be susceptible to Electro-Magnetic Interference (EMI), especially from the NASA telemetry interface. To understand any relevant issues, the prototype will be tested alongside the telemetry system at Wallops Flight Facility. Any issues that occur can then be taken into account in the

design of the final flight electronics, allowing a camera that is highly resistant to EMI to be developed.

5.3 Flight electronics

The development electronics are going to undergo detailed testing and characterization at the Open University in the UK to optimise performance and identify any problems before the flight electronics is developed. The flight electronics will also have to be sympathetic to the design restrictions that OGRE's optical design will place upon the focal plane. Once developed the flight electronics together with the EM-CCDs will be shipped to the University of Iowa in the USA for ruggedization and integration onto the rocket payload. This will occur in early/mid 2017.

6 Summary

The OGRE focal plane camera will consist of four e2v CCD207-40s as they offer a low noise, high speed performance that is essential to the successful operation of OGRE. The use of multiplication gain does involve some inherent disadvantages in the degradation of the spectral resolution performance, but this is a well known property that does not degrade the device performance below what is required for order separation.

The camera is currently under development at XCAM Ltd. and is being tested at the Open University, both in the UK. This development and testing is designed to identify problems in the current camera electronics design so that the system can be optimized. A final, flight camera, will be developed and delivered to the University of Iowa in 2017 for integration into the rocket.

The goal between now and camera delivery is to identify if the camera electronics will be able to provide a consistent performance over the course of the rocket flight. This includes looking at how battery degradation over the course of the flight will effect the potential on R ϕ 2HV and so the amount of gain, the size of the thermal mass needed to maintain a constant temperature of -80°C for the flight duration and how susceptible the camera is to EMI.

The layout of the flight camera design is dependent on the optical design of the focusing optics and grating module. This information will determine the size and shape of the wedge used to center the camera and the spacing between the CCDs. When this information is known, the final electrical, thermal and mechanical design of the camera can be agreed upon. The camera can then be built and delivered to the University of Iowa ready for integration onto OGRE before launch in 2018.

ACKNOWLEDGMENTS

I would like acknowledge all members of the OGRE team for their aid and assistance in making this work possible. This work has been supported by NASA grant NNX13AD03G.

REFERENCES

- [1] Smith, B. D., Hallman, E. J., Shull, J. M., and O'Shea, B. W., "The nature of the warm/hot intergalactic medium. I. numerical methods, convergence, and O VI absorption," *The Astrophysical Journal* **731**(1), 6 (2011).
- [2] Stocke, J. T., Keeney, B. A., Danforth, C. W., Syphers, D., Yamamoto, H., Shull, J. M., Green, J. C., Froning, C., Savage, B. D., Wakker, B., Kim, T.-S., Ryan-Weber, E. V., and Kacprzak, G. G., "Absorption-line detections of 105-106 k gas in spiral-rich groups of galaxies," *The Astrophysical Journal* **791**(2), 128 (2014).
- [3] Bregman, J. N., "The cosmic web of baryons," *White paper for 2010 Decadal Study* (2010).
- [4] McEntaffer, R. L., Osterman, S. N., Cash, W. C., Gilchrist, J., Flamand, J., Touzet, B., Bonnemason, F., and Brach, C., "X-ray performance of gratings in the extreme off-plane mount," in [*Optics for EUV, X-Ray, and Gamma-Ray Astronomy*], Citterio, O. and O'Dell, S. L., eds., *Society of Photo-Optical Instrumentation Engineers (SPIE) Conference Series* **5168**, 492-498 (Feb. 2004).
- [5] McEntaffer, R. L., Cash, W., and Shipley, A., "Off-plane reflection gratings for Constellation-X," in [*Society of Photo-Optical Instrumentation Engineers (SPIE) Conference Series*], *Society of Photo-Optical Instrumentation Engineers (SPIE) Conference Series* **7011**, 7 (July 2008).

- [6] Tutt, J. H., Holland, A. D., Murray, N. J., Hall, D. J., Endicott, J., and McEntaffer, R. L., “The use of CCDs and EM-CCDs for future soft x-ray spectrometers,” in [*Society of Photo-Optical Instrumentation Engineers (SPIE) Conference Series*], *Society of Photo-Optical Instrumentation Engineers (SPIE) Conference Series* **8443**, 0 (Sept. 2012).
- [7] Tutt, J. H., Holland, A. D., Murray, N. J., Hall, D. J., McEntaffer, R. L., Endicott, J., and Robbins, M., “A study of electron-multiplying CCDs for use on the International X-ray Observatory off-plane x-ray grating spectrometer,” in [*Society of Photo-Optical Instrumentation Engineers (SPIE) Conference Series*], *Society of Photo-Optical Instrumentation Engineers (SPIE) Conference Series* **7742**, 5 (July 2010).
- [8] Tutt, J. H., Holland, A. D., Murray, N. J., Harriss, R. D., Hall, D. J., Soman, M., McEntaffer, R. L., and Endicott, J., “The use of EM-CCDs on high resolution soft x-ray spectrometers,” in [*Society of Photo-Optical Instrumentation Engineers (SPIE) Conference Series*], *Society of Photo-Optical Instrumentation Engineers (SPIE) Conference Series* **8145**, 0 (Sept. 2011).
- [9] Jerram, P., Pool, P. J., Bell, R., Burt, D. J., Bowring, S., Spencer, S., Hazelwood, M., Moody, I., Catlett, N., and Heyes, P. S., “The LLCCD: low-light imaging without the need for an intensifier,” in [*Sensors and Camera Systems for Scientific, Industrial, and Digital Photography Applications II*], Blouke, M. M., Canosa, J., and Sampat, N., eds., *Society of Photo-Optical Instrumentation Engineers (SPIE) Conference Series* **4306**, 178–186 (May 2001).
- [10] e2v Technologies Ltd., “CCD207-40 Back Illuminated 2-Phase IMO Series Electron Multiplying CCD Sensor,” (2009).
- [11] Sze, S. M., “The LLCCD: low-light imaging without the need for an intensifier,” in [*Physics of Semiconductor Devices*], **2** (1981).
- [12] Rasmussen, A. P., Aquila, A., Bookbinder, J., Chang, C.-H., Gullikson, E. M., Heilmann, R. K., Kahn, S. M., Paerels, F., and Schattenburg, M. L., “Grating arrays for high-throughput soft x-ray spectrometers,” in [*Optics for EUV, X-Ray, and Gamma-Ray Astronomy*], Citterio, O. and O’Dell, S. L., eds., *Society of Photo-Optical Instrumentation Engineers (SPIE) Conference Series* **5168**, 248–259 (Feb. 2004).
- [13] Canizares, C. R., Huenemoerder, D. P., Davis, D. S., Dewey, D., Flanagan, K. A., Houck, J., Markert, T. H., Marshall, H. L., Schattenburg, M. L., Schulz, N. S., Wise, M., Drake, J. J., and Brickhouse, N. S., “High-Resolution X-Ray Spectra of Capella: Initial Results from the Chandra High-Energy Transmission Grating Spectrometer,” *Astrophysical Journal Letters* **539**, L41–L44 (Aug. 2000).
- [14] McCoy, J. A., Schultz, T. B., and Tutt, J. H., “A primer for telemetry interfacing in accordance with NASA standards using low cost FPGAs,” in [*UV, X-ray and Gamma-Ray Space Instrumentation for Astronomy XIX*], **9601** (2015).
- [15] Robbins, M. S. and Hadwen, B. J., “The noise performance of electron multiplying charge-coupled devices,” *IEEE Transactions on Electron Devices* **50**, 1227–1232 (May 2003).
- [16] Tutt, J. H., Holland, A. D., Hall, D. J., Harriss, R. D., and Murray, N. J., “The Noise Performance of Electron-Multiplying Charge-Coupled Devices at X-ray Energies,” *IEEE Transactions on Electron Devices* **59**, 167–175 (Jan. 2012).
- [17] Tutt, J. H., Holland, A. D., Murray, N. J., Hall, D. J., Harriss, R. D., Clarke, A., and Evagora, A. M., “The Noise Performance of Electron-Multiplying Charge-Coupled Devices at Soft X-Ray Energy Values,” *IEEE Transactions on Electron Devices* **59**, 2192–2198 (Aug. 2012).
- [18] e2v Technologies Ltd., “CCD97-00 Back Illuminated 2-Phase IMO Series Electron Multiplying CCD Sensor,” (2004).