



# Open Research Online

---

The Open University's repository of research publications and other research outputs

## Investigation of efficient adsorbents using transient analysis of adsorption chillers with Simulink

Conference or Workshop Item

How to cite:

Elsayed, Ahmed; Al-Dadah, Raya; Mahmoud, Saad; Elshaer, Amr and Bowen, James (2014). Investigation of efficient adsorbents using transient analysis of adsorption chillers with Simulink. In: Proceedings of the International Conference on Heat Transfer and Fluid Flow, International ASET Inc., article no. 199.

For guidance on citations see [FAQs](#).

© 2014 International ASET Inc.

Version: Accepted Manuscript

Link(s) to article on publisher's website:

[http://avestia.com/HTFF2014\\_Proceedings/papers/199.pdf](http://avestia.com/HTFF2014_Proceedings/papers/199.pdf)

---

Copyright and Moral Rights for the articles on this site are retained by the individual authors and/or other copyright owners. For more information on Open Research Online's data [policy](#) on reuse of materials please consult the policies page.

---

[oro.open.ac.uk](http://oro.open.ac.uk)

# Investigation of Efficient Adsorbents using Transient Analysis of Adsorption Chillers with Simulink

Ahmed Elsayed<sup>1,4</sup>, Raya Al-Dadah<sup>1</sup>, Saad Mahmoud<sup>1</sup>, Amr Elshaer<sup>2</sup>, James Bowen<sup>3</sup>

<sup>1</sup>University of Birmingham, Mechanical Engineering Department, Birmingham UK

<sup>2</sup>Kingston University London, School of Pharmacy and Chemistry, London, UK

<sup>3</sup>University of Birmingham, Chemical Engineering Department, Birmingham, UK

<sup>4</sup>Alexandria University, Mechanical Engineering Department, Alexandria, Egypt

a.m.elsayedalihussin@bham.ac.uk; r.k.al-dadah@bham.ac.uk, mahmoum@bham.ac.uk

A.Elshaer@kingston.ac.uk, j.bowen.1@bham.ac.uk

**Abstract** - With the availability of waste heat from various power stations and industrial processes, adsorption cooling systems offer advantages compared to mechanical vapour compression systems. The dynamic modelling of such system is very important as it predicts the system performance with time in terms of bed temperature, pressure, cooling capacity and coefficient of performance. Therefore there is a need for a robust simulation platform that can be used to predict the system dynamic performance under various operating conditions and accommodate design changes efficiently. This work exploits Simulink software capabilities to develop such simulation platform and investigate the effects of using different adsorbent materials and cycle times on cooling capacity and coefficient of performance. Results showed that such platform is very effective in comparative studies. Results showed that water/silica gel produce more cooling capacity compared to ethanol/activated carbon adsorbents at short cycle time, while Maxsorb has better performance at longer cycle time as its cooling capacity increases with adsorption time.

**Keywords:** adsorption chiller, Maxsorb, Simulink, Silica gel, heat pump

## 1. Introduction

In the past decades significant amount of research and development work has been carried out to develop compact and efficient adsorption cooling systems. The objectives of this effort could be realized by using properly design heat exchangers (Shi et al., 2013), cycle operating strategies (mass recovery, heat recovery, cascading, ... etc) (Hassan and Mohamad, 2012) and developing adsorbent materials with high cyclic uptake (Rezk et al., 2013). The selection of adsorbent material is a key factor in the design and manufacturing of the adsorber bed. To compare the difference between different materials, researchers utilized equilibrium cycle analysis (Daou et al., 2008) which may lead to large deviation in estimating the cyclic uptake (Daou et al, 2008; Wang and Wang, 2005). In general, the cycle transient modelling is more suitable for assessing the cooling system operation performance, while equilibrium analysis is more suitable for energy storage applications where the cycle operation time is too long.

Figure 1 shows a schematic diagram of two bed adsorption cooling system with four modes of operation: preheating, desorption, precooling and adsorption. The optimization of the transient response of such system is a challenging and time extensive process, since it involves the effect of many parameters like bed design, selection of adsorbent pairs and system configuration. Also each of these main parameters will have a number of sub-variables that have major effects on its performance, such as fins pitch, thick and height in the bed design section. Simulink is a powerful platform for transient system analysis, in this study a system of ordinary differential equations for calculating evaporation, condensation, adsorber bed temperatures and outlet water temperatures of adsorber beds and evaporator mass and uptake. Such tool is useful to test wide range of adsorbent material under real cooling system operating conditions.

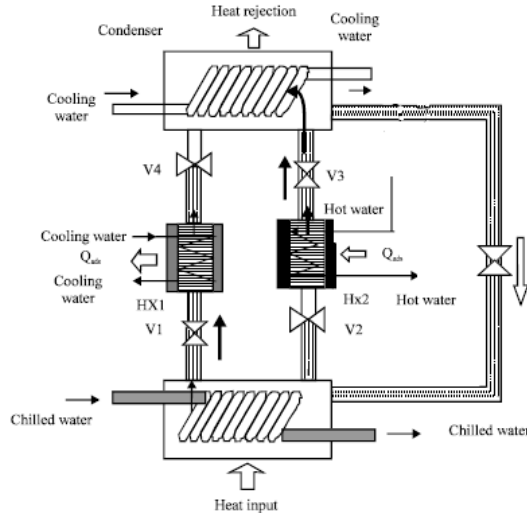

Figure1: Schematic of Two bed adsorption chiller

## 2. Simulink Modeling for Adsorption Chiller

The dynamic response of the adsorption cooling system is governed by a set of ordinary differential equations. Various simulation tools have been reported in literature to simulate the dynamic response of adsorption cooling. Such simulation tools include Modelica (Schicktanz, 2008; Bau et al., 2014), Java language (Pandele, 2008), Fortran Developer Studio software (Saha et al., 2007), Insel (Gaith and Abusitta, 2014), Matlab programming (Mitra, 2014), Trnsys (Taylan, 2010). Generally, these simulation tools requires the users to develop user defined functions and additional subroutines for the analysis of thermal systems. Simulink is a dynamic solver that uses mathematical and signal blocks with minimum need for additional user coding (Zhang et al., 2011; Sadeghlu et al., 2014). Therefore it is more robust to use for the analysis and comparative studies of adsorption cooling systems.

Figure 2 shows a schematic diagram of the Simulink model for the adsorption cooling system consisting of five main subsystems describing the governing equations for the adsorber beds, condenser, evaporator and the overall mass balance of the system. Also, the diagram shows the switching sequences governing the interaction between the various blocks.

Equations 1 to 8 describes the linear driving force model for adsorption / desorption in the beds, evaporator mass balance, evaporator heat balance, condenser heat balance and adsorber beds heat balance. The adsorption/desorption rate has been calculated using the linear driving force theory as:

$$\frac{dx}{dt} = \frac{F_p D_{so}}{R_p^2} \cdot \exp\left[-\frac{E_a}{RT}\right] \cdot (x_{eq} - x) \quad (1)$$

The overall mass balance recirculated in the chiller:

$$\frac{dM_{ref,evap}}{dt} = -M_{ads} \frac{dx_{des}}{dt} - M_{ads} \frac{dx_{ads}}{dt} \quad (2)$$

The adsorption/desorption temperature was predicted using the energy balance as:

$$\left(M_{ads}(C_{ads} + xC_{ref,v}) + M_{cu,ads}C_{cu,ads} + M_{al,ads}C_{al,ads}\right) \frac{dT_{ads}}{dt} = M_{ads}H_{ads} \frac{dx}{dt} + m_w^* C_w (T_{w,in} - T_{w,out}) \quad (3)$$

The outlet heat source/ cooling medium are calculated from the logarithmic mean temperature:

$$T_{w,out} = T_{ads} + (T_{w,in} - T_{ads}) \exp\left(-\frac{U_{ads}A_{ads}}{m_w^* C_w}\right) \quad (4)$$

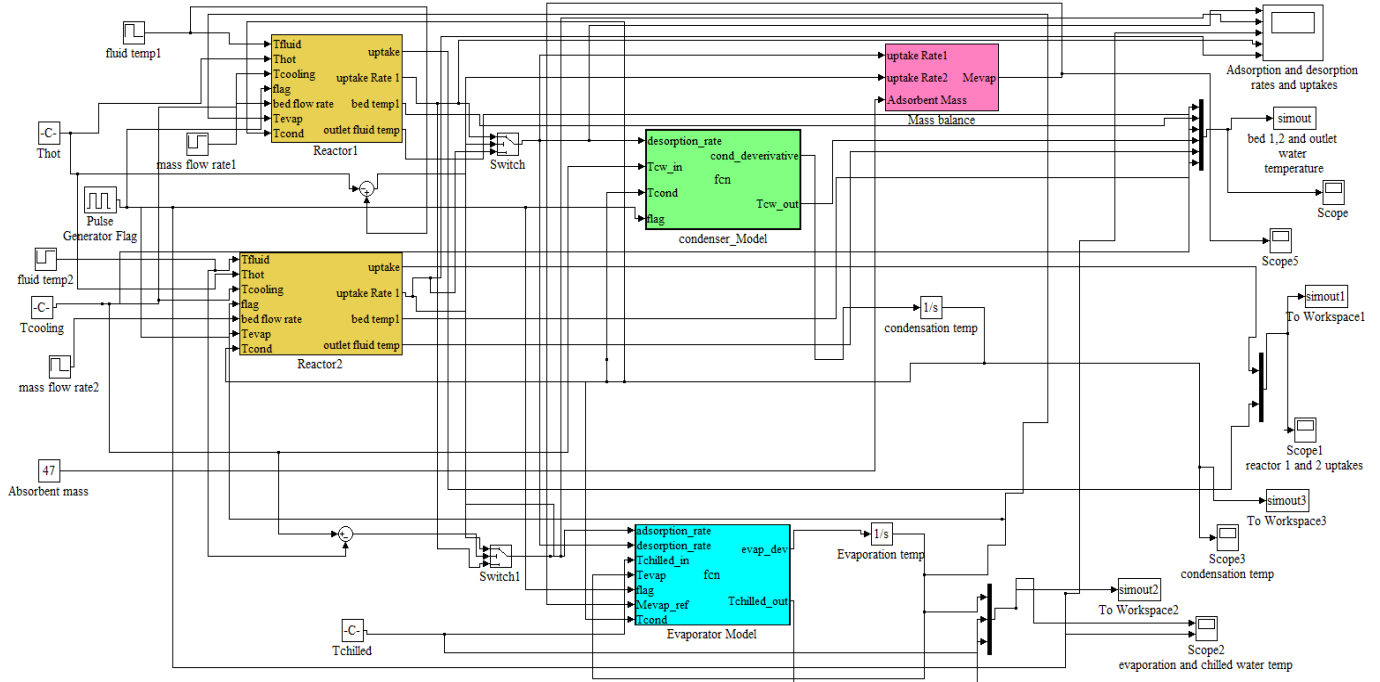

Figure 2: Arrangement of chiller component in Simulink simulation environment

The evaporation temperature was calculated as (Akahira et al., 2004):

$$\begin{aligned} & (M_{ref, evap} C_{ref, l} + M_{cu, evap} C_{cu, evap}) \frac{dT_{evap}}{dt} \\ & = - \left( M_{ads} \frac{dx_{ads}}{dt} \right) h_{fg} - M_{ads} C_{ref, l} T_{cond} \frac{dx_{des}}{dt} + m_{chill} \dot{C}_w (T_{chill, in} - T_{chill, out}) - M_{ads} C_{ref, v} T_{evap} \frac{dx_{ads}}{dt} \end{aligned} \quad (5)$$

The chilled water outlet temperature was calculated as:

$$T_{chill, out} = T_{evap} + (T_{chill, in} - T_{evap}) \exp\left(-\frac{U_{evap} A_{evap}}{m_{chill} \dot{C}_w}\right) \quad (6)$$

The condenser energy balance (Akahira et al., 2004):

$$\begin{aligned} & (M_{cu, cond} C_{cu, cond}) \frac{dT_{cond}}{dt} \\ & = - \left( M_{ads} \frac{dx_{des}}{dt} \right) h_{fg} + M_{ads} C_{ref, l} T_{cond} \frac{dx_{des}}{dt} + m_{cooling} \dot{C}_w (T_{cooling, in} - T_{cooling, out}) - M_{ads} C_{ref, v} T_{cond} \frac{dx_{des}}{dt} \end{aligned} \quad (7)$$

The cooling water outlet temperature was calculated as:

$$T_{cooling, out} = T_{cond} + (T_{cooling, in} - T_{cond}) \exp\left(-\frac{U_{cond} A_{cond}}{m_{cooling} \dot{C}_w}\right) \quad (8)$$

The cooling capacity and COP were calculated as:

$$Q_{evap} = \frac{m_{chill} \dot{C}_w \int_0^{t_{cycle}} (T_{chill, in} - T_{chill, out}) dt}{t_{cycle}} \quad (9)$$

$$COP = \frac{m_{hot} C_w \int_0^{t_{cycle}} (T_{hot,in} - T_{hot,out}) dt}{t_{cycle}} \quad (10)$$

In Simulink integral block are used to solve differential parameters as shown in figure 3a. Example of using this integral block for solving equation 1 is shown in figure 3b.

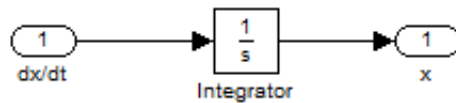

Figure 3a: Integration Block in Simulink

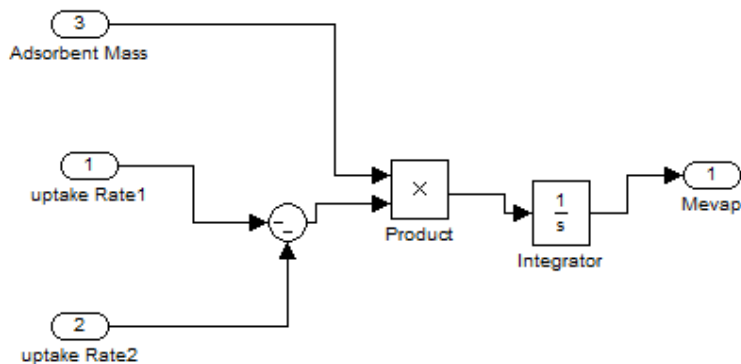

Figure 3b arrangement of overall mass balance in equation 1 in Simulink environment

### 3. Model Validation and Results

The silica gel / water adsorption cooling system described by Saha et al (1995) was modelled using Simulink using the standard cycle condition summarized in Table 1. Figure 4 shows the Simulink results compared to the data of Saha et al. It shows the temperature variation during adsorption and desorption process for the beds and the chilled water outlet temperature with time. This temperature distribution produced less than 3% deviation in the cooling capacity of the adsorption system.

Table 1: Cycle standard rating condition [Dimensions of the unit given in Saha et al.(1995)]

Physical parameter	Value	Units
Chilled water supply	14	°C
Hot regeneration water	85	°C
Cooling water	31	°C
Chilled water flow rate	0.7	Kg/s
Hot water flow rate	1.3	Kg/s
Condenser cooling water flow rate	1.3	Kg/s
Adsorber cooling water flow rate	1.6	Kg/s
Half cycle time	420	Sec
Switching time	30	Sec

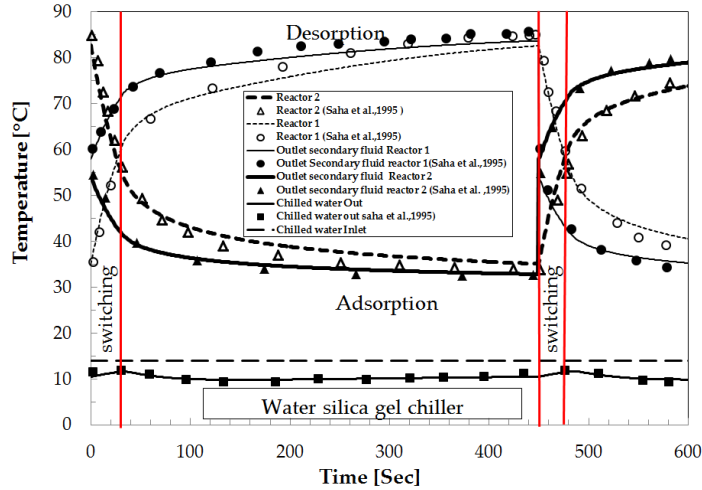

Figure 4: Validation of water/silica gel chiller

### 2. 3. Investigation of new adsorbent materials

Ethanol/activated carbon is a promising adsorption pair for cooling applications. Ethanol is an environmentally benign, non-toxic refrigerant suitable for both air conditioning and refrigeration cooling systems. Activated carbons have good adsorption affinity to alcohols such as ethanol. Maxsorb and ATO are activated carbon materials with large surface area of 3000 and 1300 m<sup>2</sup>/g respectively. In this section, Simulink modelling platform will be used to predict the performance of Maxsorb and ATO/ethanol adsorption system and carry out parametric study.

The surface area and pore volumes shown in table 2 were measured using Belsorp-mini (BEL, Japan Inc) Nitrogen adsorption/desorption at T=77K. Specific surface areas of samples were calculated according to Brunauer-Emmett-Teller (BET) model. Micropore (MP) methods were used to calculate the pore size distribution of the activated carbon samples. Before the analysis, samples of about 50-100 mg were degassed at vacuum (about 5µm Hg) and at T=353 K for 2 hours.

Table 2: Characteristics of Adsorption samples

Sample	Particle diameter [µm]	Surface area [m <sup>2</sup> /g]	Pore volume cm <sup>3</sup> /kg	Average Pore diameter [nm]
Silica gel RD	340	740	448	24.27
Maxsorb	65.6	2744	1500	1
ATO	365.1	1337	730	0.7

The adsorption isotherms for Maxsorb and ATO were developed using dynamic vapour sorption test facility (DVS). Table 3 summarizes the isotherms and kinetics models utilized for the selected pairs. All these equations were embedded in Simulink modelling. Figure 5 compares the temperature variation for one adsorbent bed using Maxsorb and ATO to that of silica gel/ water. Figure 6 shows the Coefficient of performance (COP) for the adsorption pairs shown for different adsorbent pairs. It is depicted that increasing the cycle time improves the COP of the cooling system. Additionally Maxsorb COP changes significantly relative to other adsorbent with the cycle time. The effect of cycle time on the cooling capacity is summarized in Table 4.

Table 3: Isotherm and kinetics of different samples

Water/ silica gel	
Isotherm	$x_{eq} = a * \left[ \frac{P}{P_s} \right]^b$ $a = a_0 + a_1 * T + a_2 T^2 + a_3 T^3$ $b = b_0 + b_1 * T + b_2 T^2 + b_3 T^3$ $a_0 = -6.5314; a_1 = 0.72452 \times 10^{-1}; a_2 = -0.23951 \times 10^{-3}; a_3 = 0.25493 \times 10^{-6}$ $b_0 = -15.587; b_1 = 0.15915; b_2 = -0.50612 \times 10^{-3}; b_3 = 0.5329 \times 10^{-6}$
Kinetics	$R_p = 1.7 \times 10^{-4} [m], E_a = 4.2 \times 10^4 [J/mol], D_{so} = 2.54 \times 10^{-4} [m^2/s], F_p = 15$
Ethanol/ Maxsorb	
Isotherm	$x_{eq} = x_0 \exp \left[ - \left( \frac{A}{m} \right)^n \right]$ $A = -RT \ln \left( \frac{P}{P_s} \right)$ $x_0 = 1.12934; m = 7430 [J/mol]; n = 2.31691$
Kinetics	$\left( F_p D_{so} / R_p^2 \right) = 7175.344$ $R_p = 65 \times 10^{-6} [m]$ $E_a = 40276.718 [J/mol]$
Ethanol/ ATO	
Isotherm	$x_{eq} = x_0 \exp \left[ - \left( \frac{A}{m} \right)^n \right]$ $A = -RT \ln \left( \frac{P}{P_s} \right)$ $x_0 = 0.436888; m = 9466.6 [J/mol]; n = 4$
Kinetics	$\left( F_p D_{so} / R_p^2 \right) = 189423.9$ $R_p = 365.1 \times 10^{-6} [m]$ $E_a = 47830.103 [J/mol]$

Table 4: Different pairs at the standard operating condition with different half cycle time

Physical parameter	Cooling capacity[kW]	
	450 sec	1030 sec
Maxsorb/ethanol	7.56	8.08
Water/silica gel	10.9	7.98
ATO/ethanol	3.39	2.91

The effect of evaporation temperature and condensation temperature is critical on the performance of adsorption cooling system. The evaporation temperatures are varied based on the supply chilled water temperature and flow rates. Similarly the case of condensation temperature depends on the temperature of cooling water temperature and flow rate. Figures 7a and 7b present the effect of supplied chilled water temperature on the cooling capacity and COP, while figure 8a and 8b present the effect of the cooling water temperature.

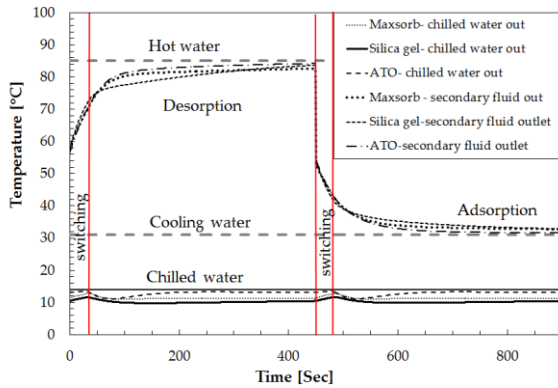

Fig. 5. Temperature variation with different adsorbent pairs

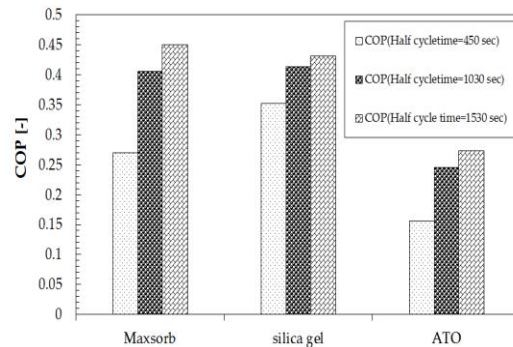

Fig. 6. COP of different pair at half cycle time of 1030 sec at standard condition

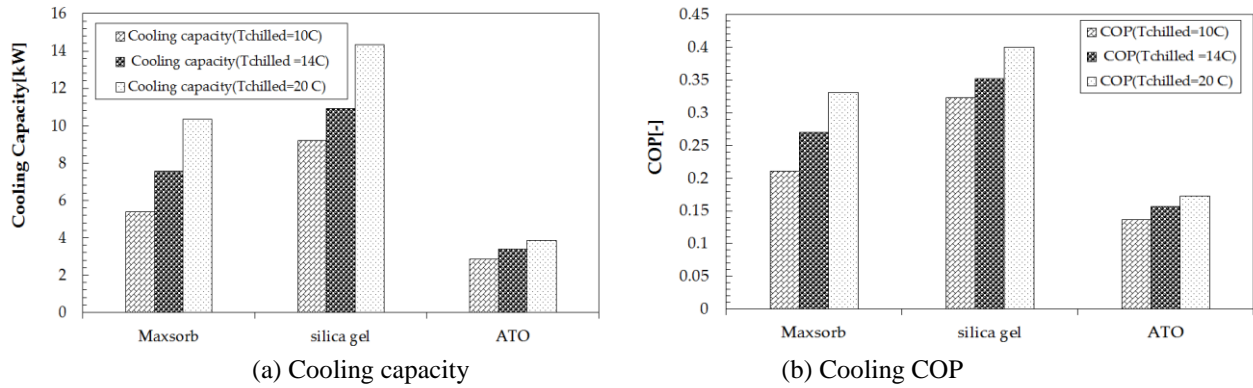

Fig. 7. Effect of chilled water temperature on the chiller cooling capacity and COP

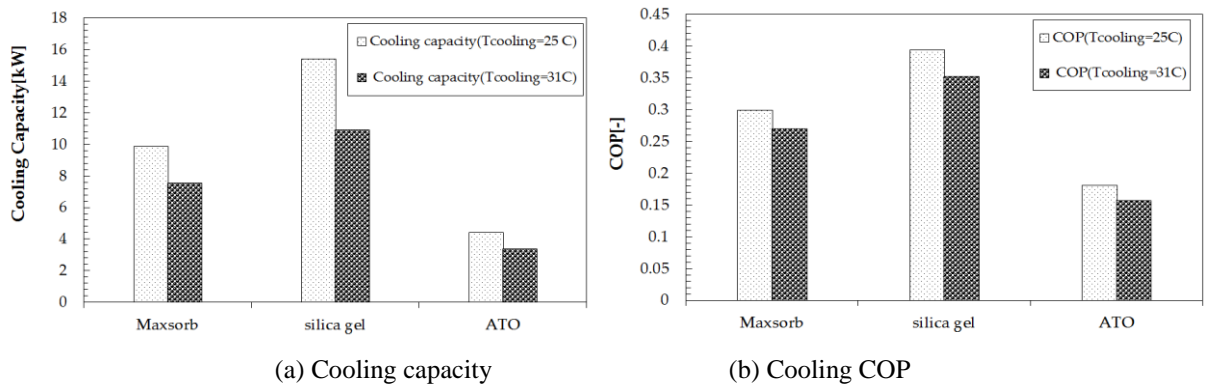

Fig. 8. Effect of cooling water temperature on the chiller cooling capacity and COP

## 5. Conclusion

The dynamic modelling of adsorption cooling systems is very important as it predicts the system performance with time in terms of bed temperature, pressure, cooling capacity and coefficient of performance. Simulink is a powerful dynamic modelling technique that has advantages compared simulation tools in terms of its simplicity and ease of use.

Simulink capabilities were used in the modelling of adsorption cooling system with three different adsorption pairs at different cycle times and operating temperatures. Results showed that silica gel has higher capacity at small adsorption time (450 sec) while Maxsorb/ethanol outperforms other materials at large cycle time of 1530 seconds. The present analysis confirms the potential of Simulink for evaluating complex thermal systems such as adsorption cooling systems.

## Acknowledgements

The authors would like to express their thanks for Knowledge Transfer Partner (KTP) and Weatherite Ltd for sponsoring the project.

## Nomenclature

A	Area [m <sup>2</sup> ]	m	Mass flow rate [kg/s]
C	Specific heat [kJ/kg]	R	Universal gas constant = 8.314 [J mol <sup>-1</sup> K <sup>-1</sup> ]
D <sub>so</sub>	Surface diffusion constant [m <sup>2</sup> s <sup>-1</sup> ]	R <sub>p</sub>	Particle radius [m]
E <sub>a</sub>	Activation Energy [J mol <sup>-1</sup> ]	T	temperature [K]
H <sub>ads</sub>	Heat of adsorption [kJkg <sup>-1</sup> ]	U	Overall heat transfer coefficient [Wm <sup>-2</sup> K <sup>-1</sup> ]
F <sub>p</sub>	Particle shape factor	x <sub>eq</sub>	Equilibrium uptake [kg/kg <sub>ads</sub> ]



M Mass [kg]

x Instantaneous uptake [kg/kg<sub>ads</sub>]

### Subscript

al Aluminium  
ads Adsorbent, adsorber  
chill Chilled  
cu Copper  
cond Condenser  
evap Evaporator

des Desorber  
in Inlet  
l Liquid  
out Outlet  
ref Refrigerant  
w water  
v Vapour

### References

- Akahira A., Alam K., Hamamoto Y., Akisawa A., Kashiwagi T.(2004). Mass recovery adsorption refrigeration cycle-improving cooling capacity. *International Journal of Refrigeration*, 27, 225-234.
- Bau U., Lanzerath F., Gräber M., Graf S., Schreiber H., Thielen N., Bardow A.(2014). Adsorption Energy Systems Library - Modeling Adsorption Based Chillers, Heat Pumps, Thermal Storages and Desiccant Systems. Proc. of 10<sup>th</sup> Modelica conference, Lund, Sweden.
- Daou K., Wang R., Yang G., Xia Z.(2008). Theoretical comparison of the refrigerating performances of a CaCl<sub>2</sub> impregnated composite adsorbent to those of the host silica gel. *International Journal of thermal Sciences*, 47, 68-75.
- Hassan H., Mohamad. A. (2012). A review on solar-powered closed physisorption cooling systems. *Renewable and Sustainable Energy Reviews* 16, 2516–2538.
- Ghaith F., Abusitta R.. Energy analyses of an integrated solar powered heating and cooling systems in UAE. *Energy and Buildings* 70 (2014) 117–126.
- Mitra S., Kumar P. , Srinivasan K., Dutta. P.(2014 in press) Simulation study of a two-stage adsorber system. *Applied Thermal Engineering*, DOI: 10.1016/j.applthermaleng.2014.04.023
- Pandele C.(2008). Sorption processes in space and control system for sorption process. Luleå university of technology , Master thesis.
- Rezk A., Al-dadah R., Mahmoud S., Elsayed A. (2013). Investigation of Ethanol/metal organic frameworks for low temperature adsorption cooling applications. *Applied Energy*, 112, 1025–1031.
- Sadeghlu, Yari M., Mahmoudi S., Dizaji H.(2014). Performance evaluation of Zeolite 13X/CaCl<sub>2</sub> two-bed adsorption refrigeration system, (2014), *International Journal of Thermal Sciences*, 80, 76-82.
- Saha B., Boelman E.,Kashiwagi T. (1995). Computer Simulation of a silica gel-water adsorption refrigeration cycle-The influence of operating conditions on cooling output. *ASHRAE Transactions: Research*, 101(1),348–357.
- Saha B., El-Sharkawy I.,Chakraborty A., Koyama S.(2007). Study on an activated carbon fiber-ethanol adsorption chiller: Part I-system description and modelling. *International of refrigeration*, 30(1), 86–95.
- Schicktzan M. (2008). Modelling of an Adsorption Chiller With Modelica. *Modelica*, session 5e.
- Shi B.,Al-dadah R., Mahmoud S., Elsayed A. and Rezk A. (2013). Mathematical And CFD Modelling for a Rectangular Finned Tube Adsorption Bed for Automotive Cooling System. Proc. of ICAE 2013, Pretoria, South Africa.
- Taylan O.(2010). Numerical modeling and performance analysis of solar-powered ideal adsorption cooling systems. M.Sc. thesis, Middle East technical university.
- Wang W.,Wang R. (2005). Investigation of non-equilibrium adsorption character in solid adsorption refrigeration cycle. *Heat and Mass Transfer*, 41(8), 680-684.
- Zhang G., Wang D., Zhang J.,Han Y., Sun W.(2011). Simulation of operating characteristics of the silica gel–water adsorption chiller powered by solar energy. *Solar Energy*, 85, 1469–1478.