

Open Research Online

The Open University's repository of research publications and other research outputs

Interpreting the information age: can we avoid anglocentrism?

Conference or Workshop Item

How to cite:

Bissell, Christopher (2014). Interpreting the information age: can we avoid anglocentrism? In: Interpreting the Information Age: New Avenues for Research and Display, 3-5 Nov 2014, Science Museum, London.

For guidance on citations see [FAQs](#).

© 2014 The Author

Version: Version of Record

Copyright and Moral Rights for the articles on this site are retained by the individual authors and/or other copyright owners. For more information on Open Research Online's data [policy](#) on reuse of materials please consult the policies page.

oro.open.ac.uk

Interpreting the information age: can we avoid anglocentrism?

Chris Bissell

Department of Computing and Communications
Faculty of Mathematics, Computing and Technology
The Open University, UK

chris.bissell@open.ac.uk

Interpreting the Information Age. Science Museum, London, 3-5 Nov. 2014

What this talk is (not) about

- *Not* the history of computers
 - Although there is still much to be said about computer development beyond the UK / USA
- Rather, some German and Russian contributors to
 - Signal and systems theory (Karl Küpfmüller)
 - Sampling theorem (in addition to Shannon)
 - Cybernetics (in addition to Norbert Wiener)
 - These are all topics that are fundamental constituents of *information engineering*

Some information engineering issues of the mid 20th century



How do we characterise the 'black box'?

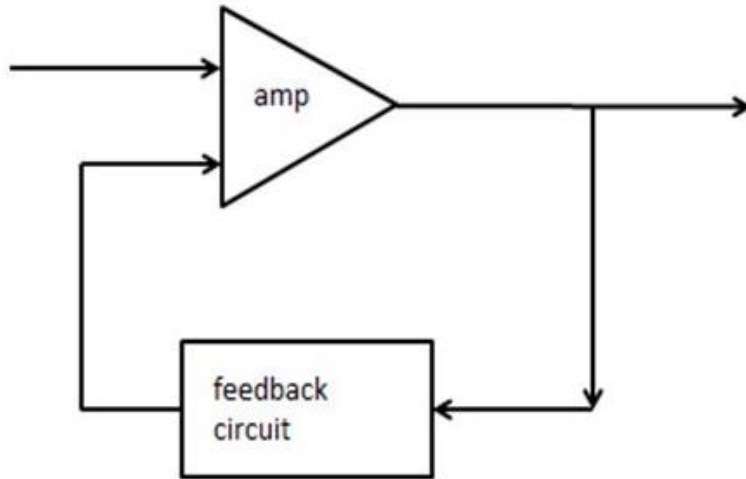

USA: Shannon, Nyquist, Carson, Foster, Bode, Black, ...

How fast must we sample to preserve all the information?

Is the feedback loop stable?

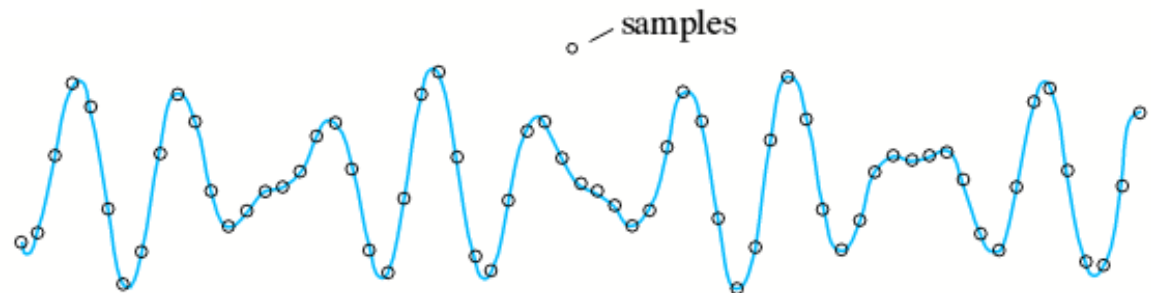

Dramatis Personae

- Karl Küpfmüller
 - Communications engineer, Nazi and SA/SS member from 1930s (rising to *Obersturmbannführer* by 1944), advisor to Doenitz (so very much part of the Nazi establishment)
- Vladimir Kotelnikov
 - first engineering account of the sampling theorem in 1933
 - went on to make major advances in cryptography
- Herbert Raabe
 - Version of sampling theorem in 1939; construction of practical devices
- Hermann Schmidt
 - Physicist by training, probably first ever Chair of Control Engineering (Berlin, 1944), trapped in Soviet zone post WW2 for a time
- Winfried Oppelt
 - Physicist by training, worked on flight control including V1 rockets, later a major force in German control engineering

Karl Küpfmüller



- Distinguished communications engineer, responsible for ground-breaking work in 1920s
- 1946-7 interned for denazification
- Met Hermann Druckrey, cancer researcher, in the camp
- Joint publication *Dosis und Wirkung* appeared 1949
- Küpfmüller applied electrical analogue modelling to cancer treatment; ideas successfully tested at Rhode & Schwarz after their release
- Prime mover in founding of German Society for Cybernetics

Küpfmüller

- Understood “time x bandwidth product”
- Developed a closed-loop stability criterion
- [one of] the first to use block diagrams
- Applied a systems (black box) approach to electronic and communications circuits and components
- Important contributor to the establishment of the concept of “information” alongside “matter” and “energy”

Küpfmüller – top and left issues



How do we characterise the 'box'?

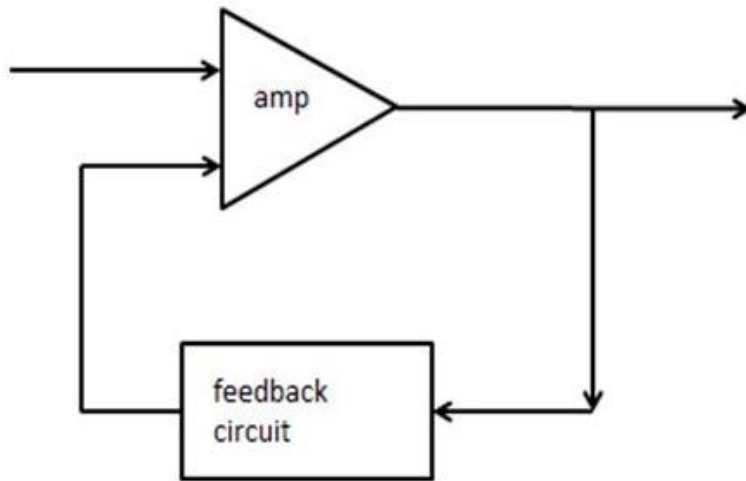

USA: Shannon, Nyquist, Carson, Foster, Bode, Black, ...

How fast must we sample?

Is the feedback loop stable?

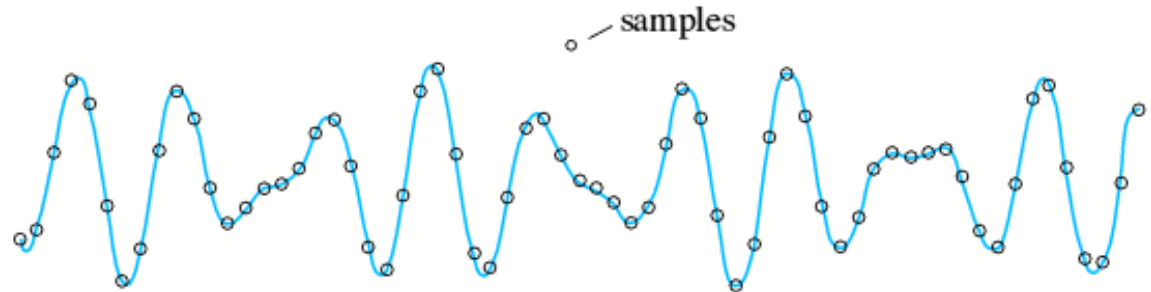

Vladimir Aleksandrovich Kotelnikov



Kotelnikov as a young man

- Sampling theorem (1933) independent of earlier (and later) work
- Scrambling and cryptography (early '40s)
- Optimal detection (1947)
- Escaped work in a *sharashka*
- Planetary telemetry and geodesy

The elderly Kotelnikov in full Soviet glory!



Herbert Raabe



- PhD thesis on pulse amplitude modulation and multiplexing, results published in 1939
- Full treatment of sampling, including bandpass signal
- Practical systems designed and built
- Work rediscovered only in late '70s, 80s

Kotelnikov and Raabe – bottom right issue



How do we characterise the 'box'?

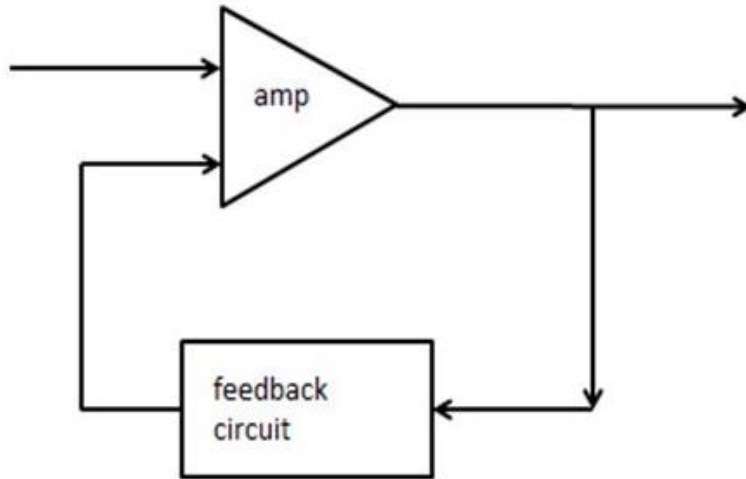

USA: Shannon, Nyquist, Carson, Foster, Bode, Black, ...

How fast must we sample?

Is the feedback loop stable?

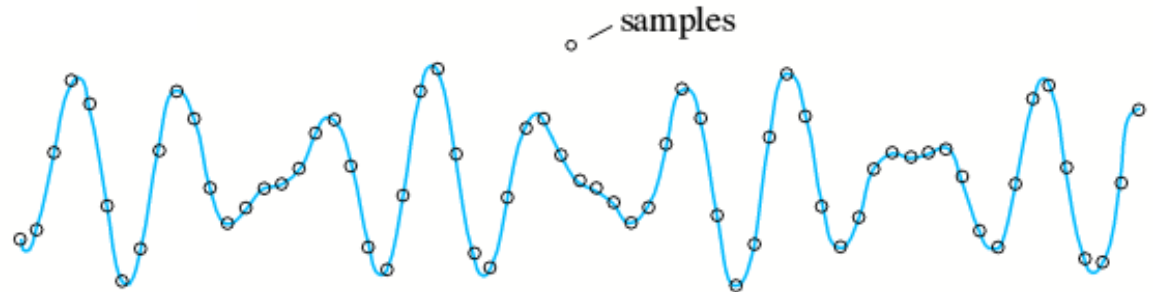

From Raabe's 1939 thesis

Switches for time-division multiplexing

Oscilloscope photos

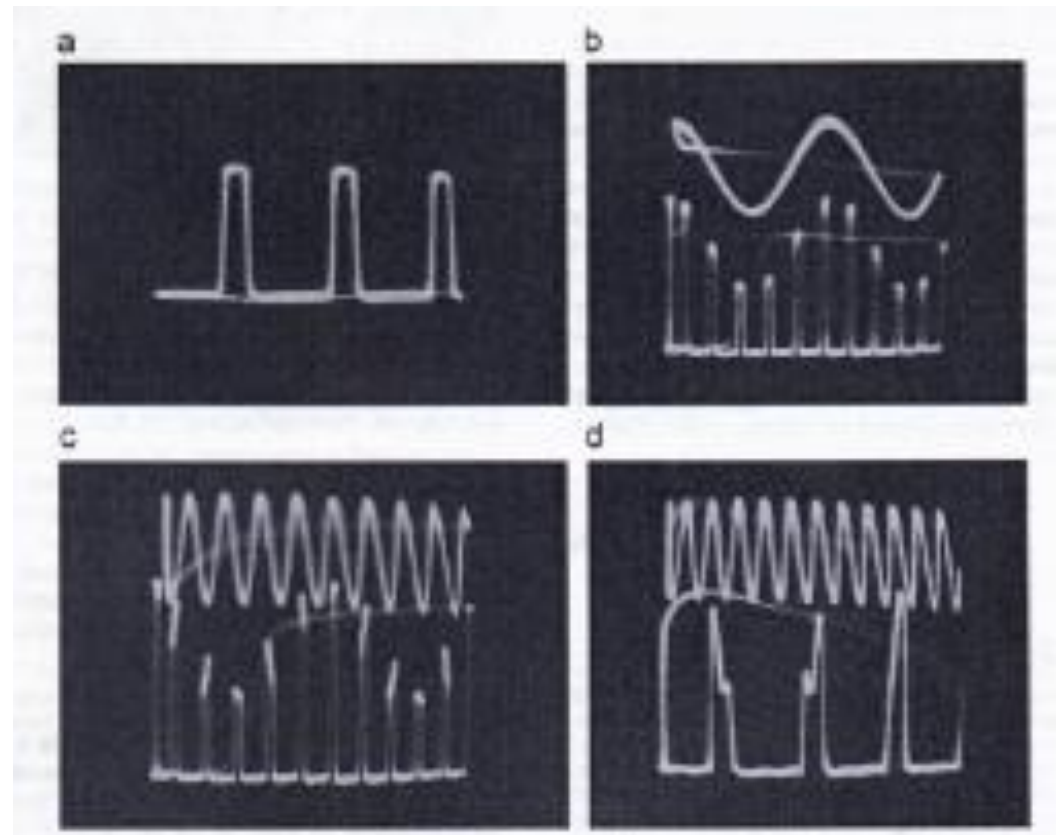
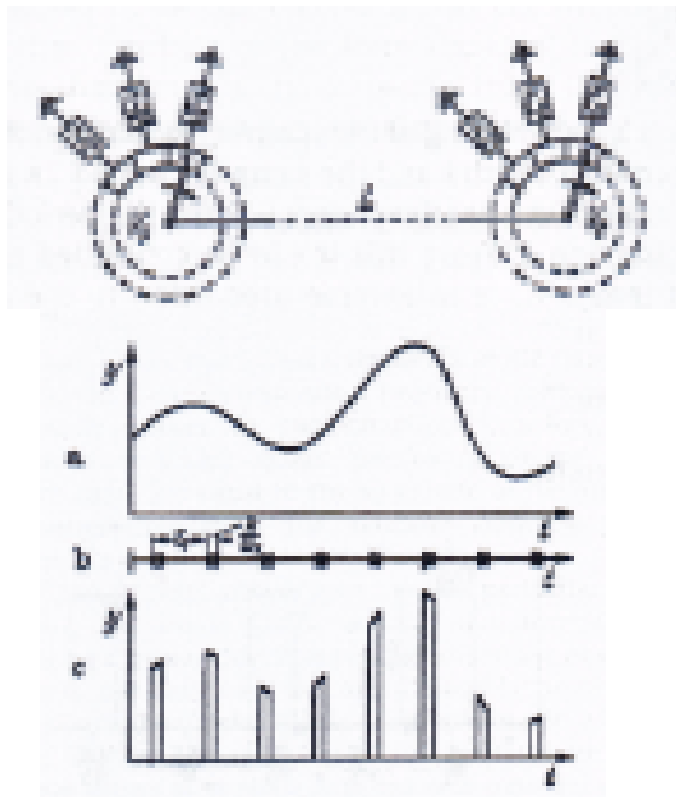

Pulse-amplitude sampling

Hermann Schmidt



- Nazi Party member 1938 -1945 (probably opportunistic, rather than ideological)
- Asked to chair VDI committee on control engineering 1939
- Workshop in October 1940
- Included presentations on blood circulation and human motion

Allgemeine Regelungskunde

- Overarching concept, applicable to
 - Engineering
 - Biology
 - Physiology
 - Economics
- Closed-loop models
- Some have argued this is a pre-Wiener German 'cybernetics'

Denkschrift 1941

- Called for the establishment of an Institute of Control Engineering
- Application areas in:
 - Industry
 - Military
 - Biology
 - Society
- “to control everything that is controllable, and to render controllable that which cannot yet be controlled”

The Wiener myth

- “... Wiener’s consistent failure to acknowledge the multiple traditions of feedback engineering that preceded him”
 - David Mindell, *Between Human and Machine*, 2002
- Wiener’s origin stories have made their way into historical accounts
- Mindell has redressed the balance, but only for the USA

Winfried Oppelt



- Colleague of Schmidt in VDI committee
- Became interested in economic and biological applications after WW2
- Published on the application of control ideas to economics, 1957
- Continued interest in cybernetic areas until his death, including the study of hypnosis

Oppelt's selected later publications

- *Der Mensch als Regler : eine Sammlung von Aufsätzen, 1970*
- *Über das Menschenbild des Ingenieurs : eine Bestandsaufnahme und offene Fragen bei der kybernetischen Modellbildung menschlichen Verhaltens, 1984*
- *Eine Schichtenanordnung zur Darstellung der hypnotische Trancezustände, 1990*

So what?

- I have presented a number of figures who are / were highly significant in Germany and Russia: there are others
- English-language histories of control engineering, telecommunications and other aspects of information engineering largely ignore such figures
- Contributions in German and Russian to history and historiography of information engineering are largely untranslated

Two examples of important, untranslated monographs

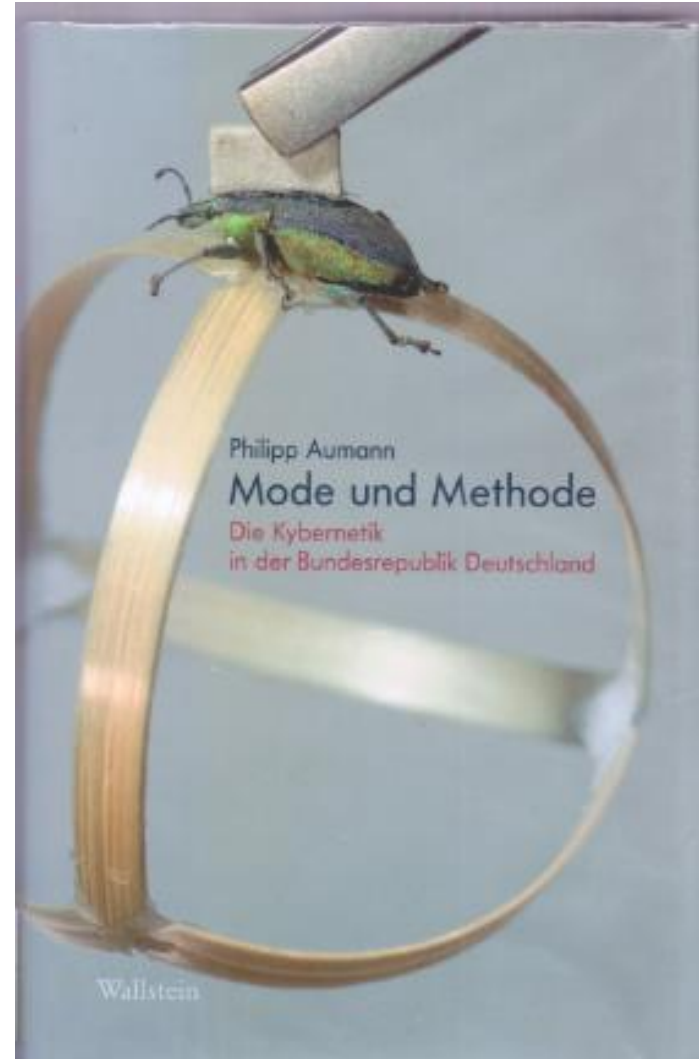
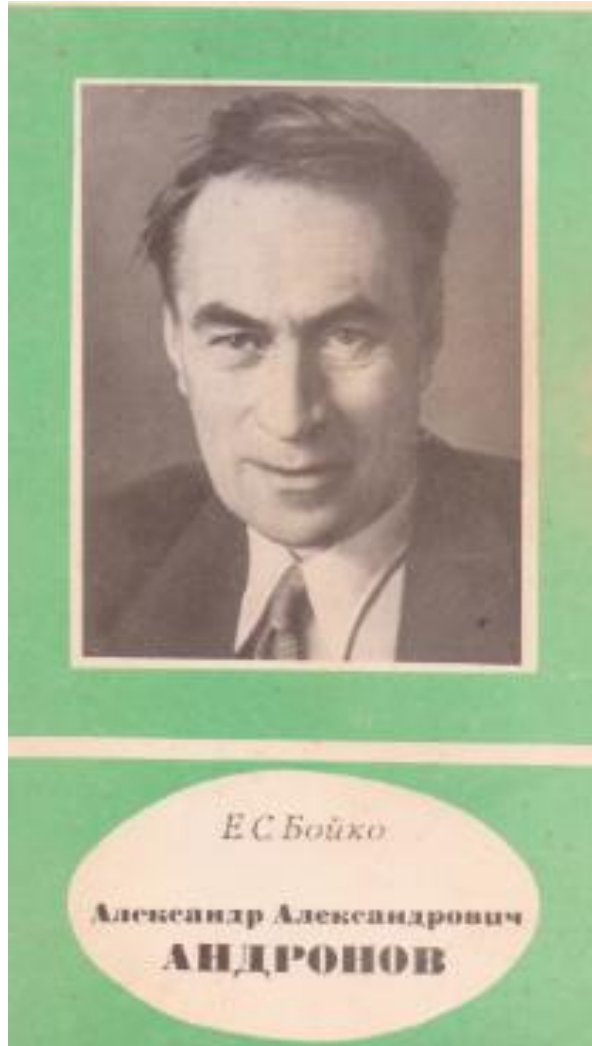

Cybernetics in East and West Germany – contrasting stories!



Is the charge of anglocentrism true?

- Priority in the history of science and technology is not particularly important, but all the researchers presented here have significant claims
- Post WW2 the US put huge resources into presenting itself as the major technological superpower
 - The Soviet Union turned inwards, and genuine claims were marred by a number of spurious ones
 - German historians of technology often concentrated elsewhere, rather than investigate the German past
- Language and translation issues must not be underestimated