

# Open Research Online

---

The Open University's repository of research publications and other research outputs

## Control in the Cold War: the genesis and early years of the International Federation of Automatic Control

Conference or Workshop Item

How to cite:

Bissell, Christopher (2013). Control in the Cold War: the genesis and early years of the International Federation of Automatic Control. In: 24th International Congress of the History of Science, Technology and Medicine, 21-28 Jul 2013, Manchester, UK.

For guidance on citations see [FAQs](#).

© 2013 The Author

Version: Accepted Manuscript

Link(s) to article on publisher's website:  
<http://www.ichstm2013.com/index.html>

---

Copyright and Moral Rights for the articles on this site are retained by the individual authors and/or other copyright owners. For more information on Open Research Online's data [policy](#) on reuse of materials please consult the policies page.

---

[oro.open.ac.uk](http://oro.open.ac.uk)



# Control in the Cold War

the genesis and early years of the  
International Federation of Automatic Control

[Chris.Bissell@open.ac.uk](mailto:Chris.Bissell@open.ac.uk)

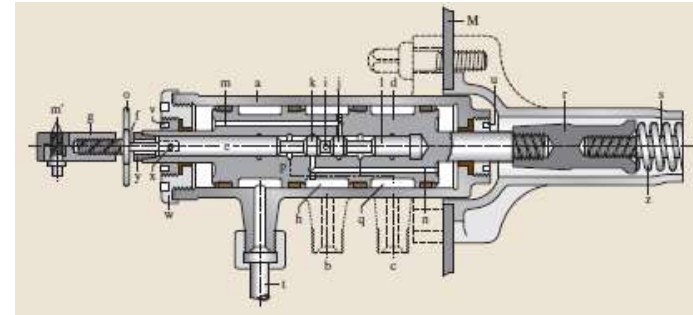
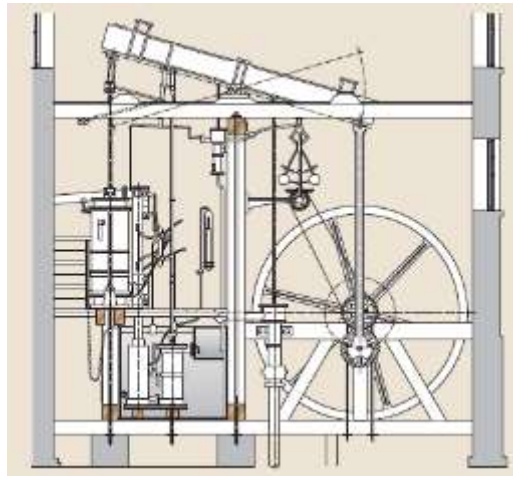
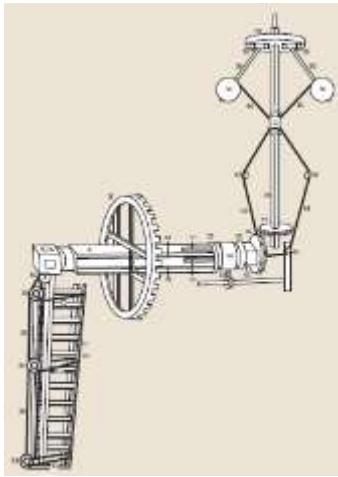

# What is control engineering?

- ❖ Essentially, forcing a physical quantity to behave in a prescribed manner – either to remain constant, or to change as desired
- ❖ Long history: antiquity, windmills, steam engine and turbine governors, ship steering, torpedo control, gun control, process plant, computer disk drives, ...
- ❖ Often involves feedback, a satisfactory theory of which emerged only in the 1930s and 1940s

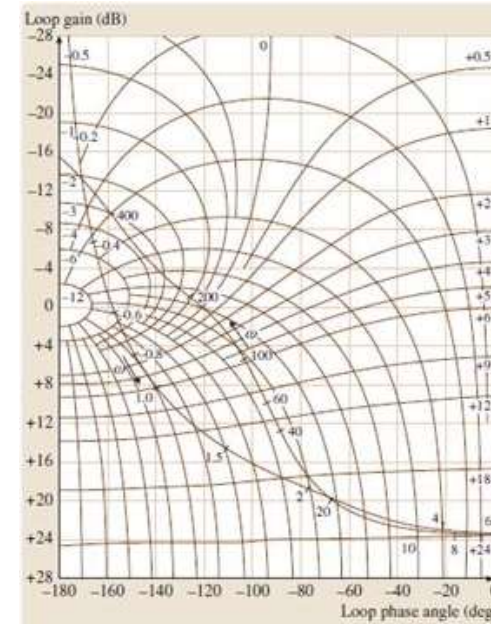
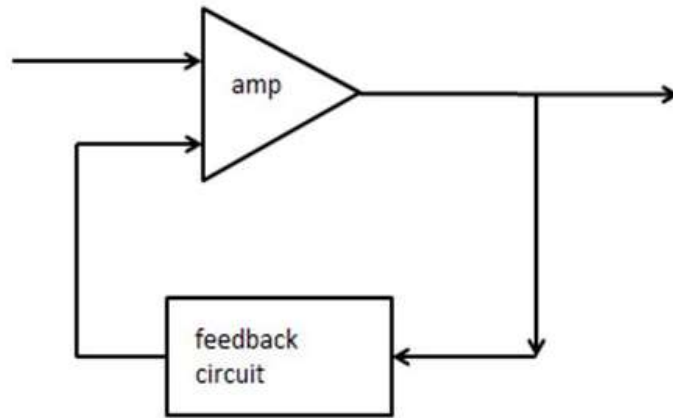

# Second World War

- ❖ Emergence of discipline of “classical control” – essentially the design of feedback loops
- ❖ Driven by high-performance gun servos
- ❖ Recognition of wider applications ... cybernetics
- ❖ USA, UK major players
- ❖ USSR, Germany less advanced

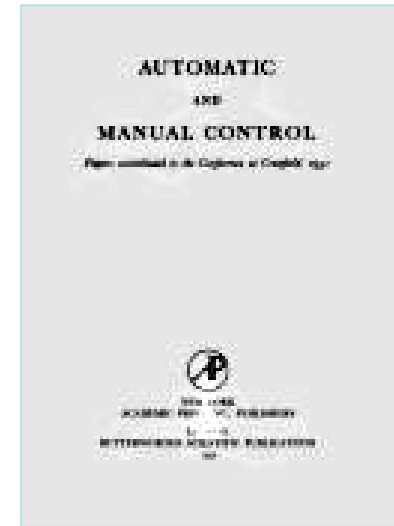
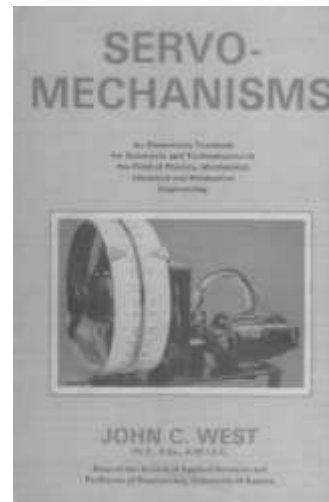
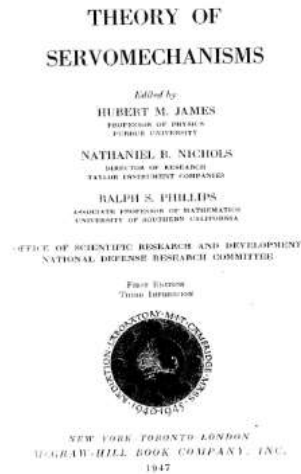

# Dissemination 1945 - 1955

- ❖ Textbooks and research papers immediately after the war
- ❖ Important early conferences late 1940s, early 1950s
  - ❖ Cranfield UK, 1951, particularly important: international participation (North America, Western Europe, Australia, Japan)

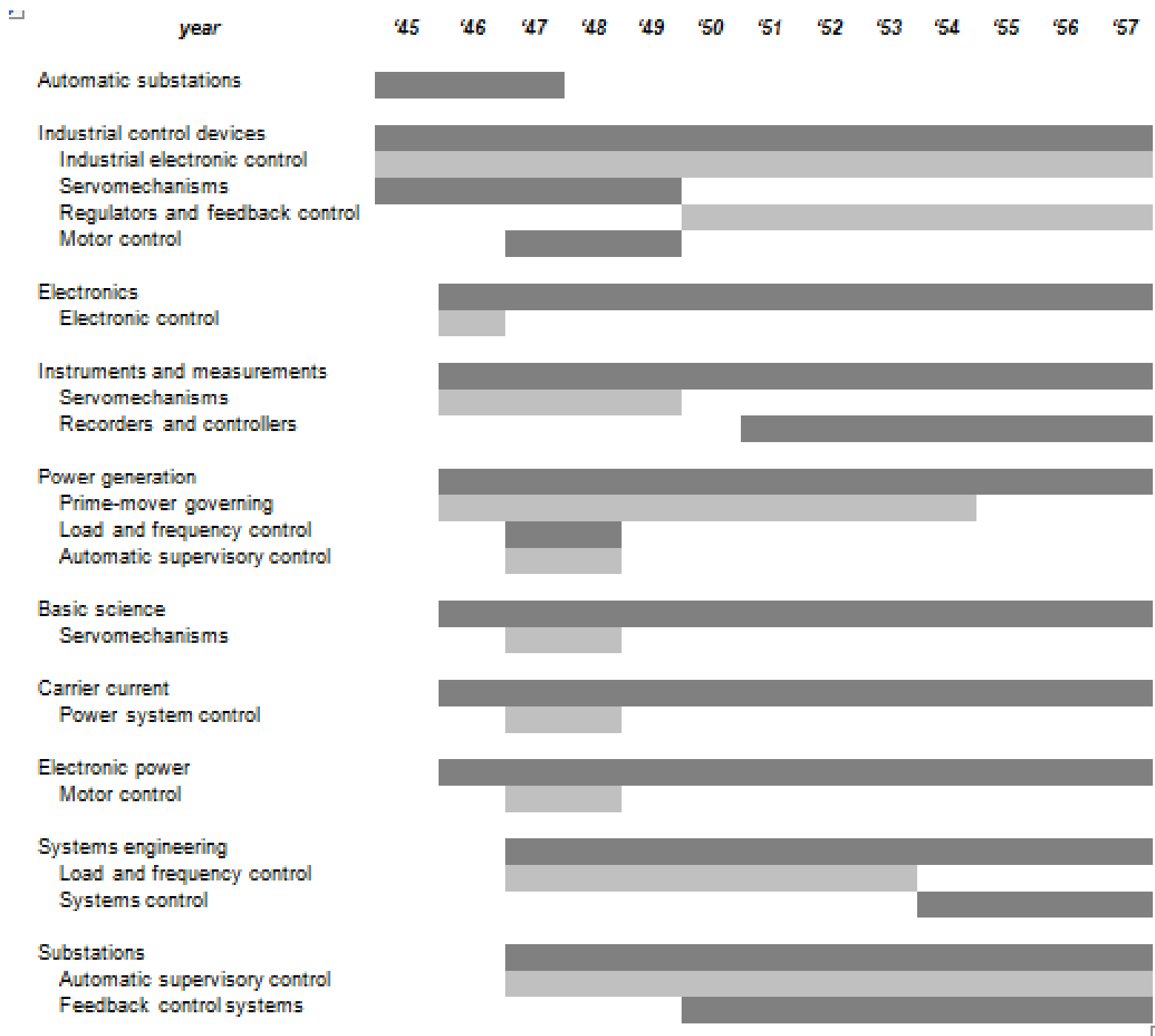
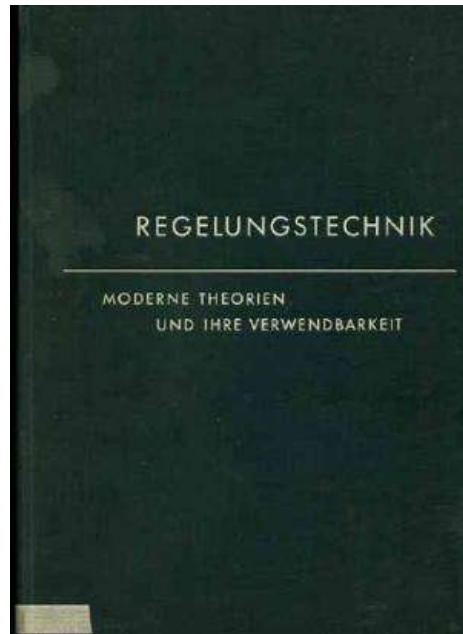

Table 1. AIEE Technical Committee structure relating to control, 1945 – 1957 (From Bennett [3])

# 1956



- ❖ Up to eight European conferences
- ❖ Most important, Heidelberg, 25-29 September
- ❖ Proposal for an international federation from G. Ruppel (Germany), R. Oldenburger (USA) and V. Broïda (France)

# The genesis of IFAC

Rufus Oldenberger: “I felt that there should be an international body [...] Dr Ruppel told me that Professor Victor Broïda of France had indicated an interest [...] and suggested that we have a meeting next day, of representatives from as many countries as were present at Heidelberg ...”



## RESOLUTION

The following undersigned are in favor of an international union of Automatic Control and are prepared to work toward this end in our own country. This union will have the following aims:

1. To facilitate the interchange of information in Automatic Control and to advance the field
2. To organize international congresses in Automatic Control.

Heidelberg, 27 Sep 1956

**Signed by 30 participants:**

Otto Grebe ,FRG

Rufus Oldenbourger;USA

A. Tustin, Gt. Britain

H. Chestnut, USA

J.F. Coales, Gt. Britain

**J.H. Westcott, Gt. Britain**

H. Märzendorfer, Austria

**M. Mesarovic, Jugoslavia**

J.M.L.Janssen, Netherlands

**Jens G. Balchen, Norway**

Gerd Müller, FRG

P.J. Novacki, Poland

Heinrich Kindler, GDR

Rudolf Oetker, FRG

Werner Pohlenz, GDR

G. Evangelisti, Italy

J. Boas-Popper, Israel

M. Ajinbinder, Belgium

Ph. Passau, Belgium

Victor Broida, France

Paul Profos, Switzerland

L.V. Hamos, Sweden

**Vladimir Strejc, CSSR**

**B. Hanus, CSSR**

A.M. Letov, USSR

Keisuke Izawa, Japan

G. Ruppel, FRG

D.B. Welbourn, Gt. Britain

W.A. Ratscheev, USSR.

Jens R. Jensen, Denmark

# The genesis of IFAC

- ❖ Provisional committee met at the offices of the VDI/VDE specialist control group in Düsseldorf in April 1957
- ❖ IFAC came into being at a meeting in Paris in September that year.
- ❖ First president the American Harold Chestnut; Vice-Presidents the Russian A. M. Letov and the Frenchman V. Broïda.
- ❖ Letov would be the second president and the first IFAC Congress would be held in Moscow in 1960

# Constitution of IFAC

- ❖ One organisation per Nation State, United Nations model
- ❖ UK and USA organised overarching bodies (control councils)
- ❖ A problem with Germany, due to divided nature



# The Moscow Conference, 1960

- ❖ Around 1500 participants, about half Russian, half foreign
- ❖ Westerners accommodated in Hotel Ukraina
- ❖ Consecutive, not simultaneous, translation
- ❖ Only modest contact between Soviet and Western delegates



# Views from the West

Soviet research lags behind Western developments, but the gap is neither large nor based on a lack of understanding [...] the Soviets will move ahead rapidly if priority [...] is given to their research.

Edward Feigenbaum



# Views from the West

Back in the hotel, we had noticed the elevator never stopped at the 13th floor. One day I was in the elevator alone, and by accident, it stopped at the 13th floor and the door opened. I could look out and see down the hallway—racks and racks of gear with glowing tubes. The whole floor was electronics. So this is why they put foreigners in this hotel ...

Bernard Widrow



# Widrow again

The main benefit of attending that first IFAC meeting was the personal contacts that you made. I made a personal contact with a colleague who became a friend for life. That was Prof. Tsympkin—Yakov Zalmanovich Tsympkin—who died a few years ago. [...] He knew all about my doctoral thesis [...] I was astounded that he would know about the work of an insignificant young guy in the United States. How would they pick that up so far way in Russia?



# And a Brit

## **In the Russian manner**

One should not, perhaps, end this account without commenting on the Russian habit of doing everything at the last possible moment and being always a little vague about the time. The atmosphere in which we had been living for a fortnight was that of a place apart, and, at the time, the Western world seemed rather far away. J. H. WESTCOTT



# On the General Theory of Control Systems

R. E. KALMAN

## Introduction

In no small measure, the great technological progress in automatic control and communication systems during the past two decades has depended on advances and refinements in the mathematical study of such systems. Conversely, the growth of technology brought forth many new problems (such as those related to using digital computers in control, etc.) to challenge the ingenuity and competence of research workers concerned with theoretical questions.

Despite the appearance and effective resolution of many new problems, our understanding of fundamental aspects of control has remained superficial. The only basic advance so far appears to be the *theory of information* created by Shannon<sup>1</sup>. The chief significance of his work in our present interpretation is the discovery of general 'laws' underlying the process of information transmission, which are quite independent of the particular models being considered or even the methods used for the description and analysis of these models. These results could be compared with the 'laws' of physics, with the crucial difference that the 'laws' governing man-made objects cannot be discovered by straightforward experimentation but only by a purely abstract analysis guided by intuition gained in observing present-day examples of technology and economic organization. We may thus classify Shannon's result as belonging to the *pure theory* of communication and control, while everything else can be labelled as the *applied theory*; this terminology reflects the well-known distinctions between pure and applied physics or

In Section 3 we introduce the models for which a fairly complete theory is available: dynamic systems with a finite dimensional state space and linear transition functions (i.e. systems obeying linear differential or difference equations). The class of random processes considered consists of such dynamic systems excited by an uncorrelated gaussian random process. Other assumptions, such as stationarity, discretization, single input/single output, etc., are made only to facilitate the presentation and will be absent in detailed future accounts of the theory.

In Section 4 we define the concept of *controllability* and show that this is the 'natural' generalization of the so-called 'dead-beat' control scheme discovered by Oldenbourg and Sartorius<sup>21</sup> and later rederived independently by Tsytkin<sup>22</sup> and the author<sup>17</sup>.

We then show in Section 5 that the general problem of optimal regulation is solvable if and only if the plant is completely controllable.

In Section 6 we introduce the concept of *observability* and solve the problem of reconstructing unmeasurable state variables from the measurable ones in the minimum possible length of time.

We formalize the similarities between controllability and observability in Section 7 by means of the *Principle of Duality* and show that the Wiener filtering problem is the natural dual of the problem of optimal regulation.

Section 8 is a brief discussion of possible generalizations and currently unsolved problems of the pure theory of control.

## IFAC Congresses 1960 - 2005

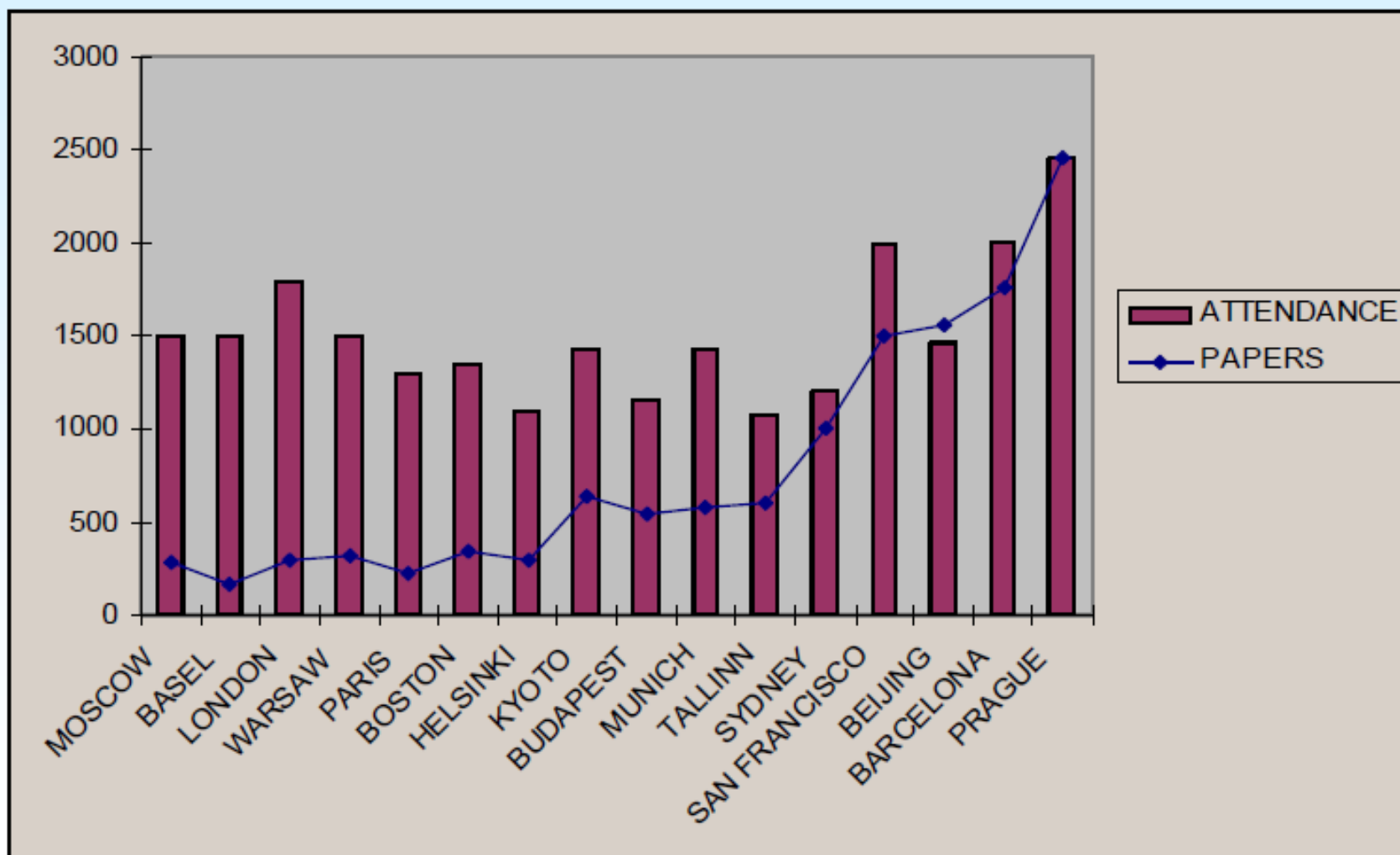

Source: St. Kahne, 2006

# IFAC achievements

- ❖ Certainly did not reduce the number of conferences!
- ❖ Papers at IFAC congresses became increasingly theoretical
- ❖ But the congress remains one of the most important meetings in the field
- ❖ Wide range of technical committees (TCs)
- ❖ Most significant publications: *Automatica* and *Control Engineering Practice*

# Current coordinating committee structure, each CC with 4-6 TCs

CC 1 - Systems and Signals

CC 2 - Design Methods

CC 3 - Computers, Cognition and Communication

CC 4 - Mechatronics, Robotics and Components

CC 5 - Manufacturing and Logistics Systems

CC 6 - Process and Power Systems

CC 7 - Transportation and Vehicle Systems

CC 8 - Bio- and Ecological Systems

CC 9 - Social Systems

# Example: Technical Committee on Aerospace

- ❖ Established in 1963.
- ❖ First Symposium organized in June 1965 by the Norwegian Host Society in Stavanger, Norway, Title: **“First IFAC Symposium on Automatic Control in the Peaceful Uses of Space”**.
- ❖ Nineteen symposia to date
- ❖ Nine workshops

# Automatica

## A Journal of IFAC, the International Federation of Automatic Control



*Automatica* publishes papers on original theoretical and experimental research and development in the **control of systems**, involving all facets of **automatic control theory** and its applications. Preferably, theoretical papers should include applications; papers dealing with components and systems should include theoretical background and, where appropriate, economic implications.

It is intended to publish only those papers, including those based on IFAC meeting presentations, which may be regarded as new, worthwhile contributions in this field.

Papers should be intelligible to the general body of control engineers, which requires that specialized techniques, terminology and acronyms be well defined and/or referenced.



## Control Engineering Practice

### A Journal of IFAC, the International Federation of Automatic Control

*Control Engineering Practice* strives to meet the needs of industrial practitioners and industrially related academics and researchers. It publishes papers which illustrate the direct application of **control theory** and its supporting tools in all possible areas of **automation**. As a result, the journal only contains papers which can be considered to have made significant contributions to the application of **control techniques**. It is normally expected that practical results should be included, but where simulation only studies are available, it is necessary to demonstrate that the simulation model is representative of a genuine industrial application.

# 5- year impact factors, 2012

- ❖ Automatica: 3.94
- ❖ Control Engineering Practice: 2.03
- ❖ *IEEE Control Systems Magazine*: 4.33
- ❖ *IEEE Trans. Systems, Man and Cybernetics*: 3.95
- ❖ *IEEE Trans. Automatic Control*: 3.41



# Conclusion

- ❖ A remarkable international collaboration at the height of the Cold War
- ❖ Developed in a way not entirely as the ‘founding fathers’ had anticipated
- ❖ Did not replace other international conferences, nor an ever-increasing number of technical publications
- ❖ Remains an important, independent, technical body