



# Open Research Online

---

The Open University's repository of research publications and other research outputs

## A new cross-layer dynamic spectrum access architecture for TV White Space cognitive radio applications

Conference or Workshop Item

How to cite:

Martin, J. H.; Dooley, L. S. and Wong, K. C. P. (2013). A new cross-layer dynamic spectrum access architecture for TV White Space cognitive radio applications. In: Intelligent Signal Processing (ISP) Conference 2013, 2-3 Dec 2013, London.

For guidance on citations see [FAQs](#).

© 2013 IET

Version: Accepted Manuscript

Link(s) to article on publisher's website:

<http://conferences.theiet.org/isp/programme/index.cfm>

---

Copyright and Moral Rights for the articles on this site are retained by the individual authors and/or other copyright owners. For more information on Open Research Online's data [policy](#) on reuse of materials please consult the policies page.

---

[oro.open.ac.uk](http://oro.open.ac.uk)

# A New Cross-Layer Dynamic Spectrum Access Architecture for TV White Space Cognitive Radio Applications

J. H. Martin FIET<sup>1/2</sup>, L. S. Dooley<sup>2</sup>, K. C. P. Wong MIET<sup>2</sup>

<sup>1</sup>Alcatel-Lucent Telecom Limited  
Coldra Woods, Newport  
South Wales, NP18 2YB, United  
Kingdom

<sup>2</sup>Dept. of Computing and Communications,  
The Open University, Milton Keynes,  
MK7 6AA, United Kingdom

## Abstract

As evermore applications and services are developed for wireless devices, the dramatic growth in user data traffic has led to the legacy channels becoming congested with the corresponding imperative of requiring more spectra. This has motivated both regulatory bodies and commercial companies to investigate strategies to increase the efficiency of the existing spectrum. With the emergence of cognitive radio technology, and the transference of TV channels from analogue to digital platforms, a unique opportunity to exploit spectrum by mobile digital service providers has emerged, commonly referred to as *TV White Space* (TVWS). One of the challenges in utilising TVWS spectrum is reliable primary user (PU) detection which is essential as any unlicensed secondary user has no knowledge of the PU and thereby can generate interference. This paper addresses the issue of PU detection by introducing a new dynamic spectrum access algorithm that exploits the unique properties of how digital TV (DTV) frequencies are deployed. A fuzzy logic inference model based on an *enhanced detection algorithm* (EDA) is used to resolve the inherent uncertain nature of DTV signals. Simulation results confirm EDA significantly improves the detection probability of a TVWS channel compared to existing PU detection techniques, while providing consistently low false positive detections. The paper also analyses the impact of the hidden node problem on EDA by modelling representative buildings and proposes a novel solution.

## 1 Introduction

The unused television (TV) bands which have arisen from the platform transference from analogue to digital TV (DTV) are commonly called *TV White Space* (TVWS) [1-3]. These have been created by the localised allocation of DTV frequencies, so frequencies not allocated in a particular geographical area are available for usage by, for example, *cognitive radio networks* (CRN), services and applications. Regulators including the Office of Communications (Ofcom) in the UK and the US Federal Communications Commission (FCC), have recently adopted proposals to allow new broadband devices to operate within TVWS [1], [2], [4].

To allow CRN to access TVWS, both Ofcom and FCC have imposed a number of constraints relating specifically to the access methods and spectral definition [2], [4]. Concomitantly,

the IEEE 802.22 community [2], [5], [6] have developed a framework standard for TVWS. All these constraints to some degree influence the secondary access channel performance of the sensing solutions presented in this paper.

One of the major requirements of any system wanting to access TVWS is reliable detection of *primary users* (PU) to avoid interference to local users of the DTV system. Both Ofcom and FCC have favoured the geo-location database approach [2], however this strategy entails considerable expense and effort to implement and keep the database infrastructure updated. Furthermore, the geo-location database utilises theoretical algorithms for calculating the safety margins to protect the PU which are not based upon real life measurements. Due to these drawbacks, alternative sensing mechanisms are considered in this paper.

This paper investigates a cross layer mechanism called the *cross layer cognitive engine* (CLCE) which shares information between the medium access control (MAC) and physical layers, so sensing measurements can influence spectrum access decisions [3], [7]. The CLCE forms the basis of a new *enhanced detection algorithm* (EDA) which defines the way a TVWS channel is accessed. The EDA utilises the patterns in which the DTV frequencies are deployed to determine whether a PU is occupying a channel, and importantly utilises an energy detector which exploits local real-time measurements in the decision making.

The benefits of using an energy sensing detection strategy as opposed to the more sophisticated cyclostationary or Wavelet detection techniques [5] [6] is the lower cost of implementation which is crucial when cognisance is made that this will be implemented in all distributed broadband wireless access points. To examine the vital trade-off between cost and performance, this paper will provide quantitative results on the performance and complexity of applying a covariance-based detector as the comparator to the proposed EDA solution.

One of the key problems encountered within a sensing detection system is the "hidden node" issue which this paper both characterises and also proposes a solution within the EDA context. From this a flexible framework that is able to sense effectively TVWS channel access can be implemented.

The remainder of this paper is organised as follows. Section 2 provides a review of existing TVWS techniques which

highlight the main design challenges for dynamic access control, whilst the new CLCE/EDA implementation is presented in Section 3. Section 4 provides details of the test models used, while Section 5 discusses the simulation results for the CLCE/EDA paradigm. Section 6 explores possible solutions to the "hidden node" problem, with Section 7 providing some concluding comments.

## 2 Background

Existing TVWS work [1-6] can be divided into three distinct sectors: practical implementations of TVWS networks, regulatory frameworks and the development of *dynamic spectrum access* (DSA) algorithms.

The UK TVWS implementation and trial in [4] was undertaken in Cambridge and conducted by a consortium including Ofcom, BBC, Alcatel-Lucent and BT. The trial proved that both CRN and PU can co-exist in the TVWS spectrum, with the study also revealing that TVWS bandwidth availability affords potential benefits to providing broadband access, especially in rural areas. The one issue not analysed in this study was an examination of different sensing applications as only a geo-location database was used for DSA.

A broad review of the general regulatory landscape can be found in [1],[2],[5],[6], with [1] and [2] describing the UK, European and North American regulatory issues and developments including sensing sensitivity thresholds. In contrast,[5] and [6] examine the IEEE 802.22 *wireless regional area network* (WRAN) standard which is considered in North America.

The next two examples of DSA algorithms in [5] and [6] form the benchmark on which the EDA can be compared. [5] explores spectrum sensing in the context of the main TV standards deployed in China, namely Digital Terrestrial Multimedia Broadcast (DTMB), China Multimedia Mobile Broadcasting (CMMB) and Phase Alternating Line-D/K (PAL-D/K). For the purposes of comparison, the DTMB was only reviewed since it is the standard that most resembles both the UK standard and IEEE 802.22 WRAN standard, where the detection probability and false detection targets are 90% and 10% respectively in an 8MHz DTV channel.

In [5], an autocorrelation algorithm for spectrum sensing was developed based upon the correlation of the frame headers using autocorrelation, comb correlation and decision blocks, though little insight into the noise regime applied during the experiments was provided.

In contrast, [6] examines the development of spectrum sensing algorithms for ATSC in full (DTV), NTSC in full (analogue) and radio microphones in North America. The spectrum sensing algorithm for ATSC and NTSC is a unified signature-based spectrum sensing algorithm, (for ATSC this is the autocorrelation of the SYNC segment of the frame). The ATSC

standard uses a 6MHz bandwidth and FCC has defined the sensing threshold at -116dBm, while in the UK, the bandwidth used is 8MHz and corresponding sensing threshold is -120dBm [2]. In its conclusions, [6] states that spectrum sensing algorithms can be used to detect DTV primary signals so channel availability can be readily identified in order to deploy TVWS applications.

## 3 The EDA implementation for DSA

The rationale behind the EDA is to refine the CLCE [3], [7] to specifically achieve better channel allocation decisions, so the constituent blocks which have been implemented are those relating to mobility, decision and sensing. The EDA does not consider wireless microphones however, as [4] found that FM microphones produce strong inter-modulation products even in adjacent channels. This would mean that EDA could not use these channels because the noise level would be too high to utilise the channel for secondary access and hence would not interfere with any wireless microphones.

The EDA exploits *a priori* information concerning the DTV system and shares this between the MAC and physical layers together with the cognitive cycle in making a spectrum access decision. The consequence of this *cross layer processing* (CLP) design is to transform an energy sensor into a feature sensor as will be evidenced in Section 5. This ensures consistently superior performance in terms of both detection and false detection probability compared with existing sensing techniques i.e., [5] and [6], and the stand-alone energy sensor.

The EDA is divided into two distinct component blocks which will now be individually considered.

### 3.1 Signal Sensing

This block defines the various detection transitions covering the signal range from no signal through to weak *uncertain* and strong signals [3]. The different detection ranges assumes a mobile sensor of height 1.5m at each TVWS channel.

A fuzzy logic function assigns the incoming RF input signal into three possible states, namely Unoccupied, Uncertain and Occupied, according to their membership functions

In setting the detection thresholds, the *unoccupied* sensor output range lies between the DTV signal floor (-400dBm i.e. No DTV signal) and the sensor output which corresponds to a *receive signal strength* (RSS) of -120 dBm as defined in [2]. This Simulink model output will then determine  $X_U$  the sensor threshold for the Unoccupied to Uncertain states. The output of the energy sensor is then given by:

$$\max_{0-T} X_U = |\mathcal{F}(RSS_y)|^2 \quad (1)$$

Where  $X_U$  is the RF energy for a RSS of -120dBm at the receiver antenna (RSS<sub>y</sub>) and  $T$  is the sensing period.

The *uncertainty* band is defined between the sensor outputs at the aforementioned -120 dBm threshold through to the sensor output at  $X_0$ , which is the distance which yields a corresponding  $RSS_x$  probability of 99% that a user can correctly decode the DTV signal. To determine this threshold, an Egli model [8] was used with a distance which produces a *bit error rate* (BER) equal to  $2 \times 10^{-6}$  in the DTV receiver:

The output of the energy sensor is given by:

$$\max_{0-T} X_O = |F(RSS_x)|^2 \quad (2)$$

where  $X_0$  is the RF energy for a BER of  $2 \times 10^{-6}$  using the Egli propagation model terrain factor of 99% at a distance  $x$ , and  $RSS_x$  is the received signal strength for a fade probability of 0.99 thereby giving a BER =  $2 \times 10^{-6}$ .

For comparative purposes, a basic *RF detection* algorithm has been also implemented in which the detection was stipulated using real data [9], [10] from the Bristol coverage area which only gives a binary response i.e., either ON (*occupied*) or OFF (*unoccupied*) with no *uncertain* state. This data was compared with results from the Egli propagation model with differing terrain factors until the best match was achieved which was obtained using a 97% terrain factor model. This terrain factor was then used in the simulation model to generate the requisite propagation data to analyse the performance of the EDA.

A further comparison was made by investigating the use of a covariance detection method which can be used to negate the effect of the lower threshold being under the Gaussian noise floor (-105dBm). This method fits an autoregressive model to the signal by minimising the forward prediction error in a LS (least squares) sense to minimise the errors generated by the desired signal being below the noise floor. The respective covariance thresholds which correspond to the energy  $|F|^2$  thresholds are given by:

$$\max_{0-T} X_U = \text{cov} |RSS_y| \quad (3)$$

$$\max_{0-T} X_O = \text{cov} |RSS_x| \quad (4)$$

From these threshold calculations, the membership functions can be derived with the sensor output thresholds transitioning at a probability of 0.5.

### 3.2 Spectrum Pattern Sensing

The EDA scans  $B_x$  channels up and down from the channel under investigation, where  $B_x$  is an integer. For a particular channel which lies within the *uncertainty* range and any other channel which is either within  $B_x$  up or down and also lies within either the *uncertain* or *occupied* detection ranges, then the outcome is weighted according to a set of fuzzy rules which will be defined shortly. This reflects that DTV channels

in a local area are generally deployed in a cluster configuration in which another DTV channel either  $B_x$  channels up or down can be located. The EDA detection/false detection response against  $B_x$  for signal strength of -120dBm and averaged over 15 Major DTV transmitter sites in the UK, is shown in Figure 1:

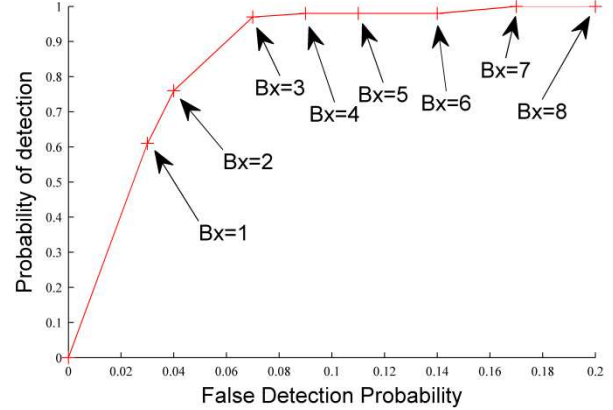

Figure 1 EDA Response with a signal of -120dBm and varying values of  $B_x$

Figure 2 shows the fuzzy logic inference model for EDA, which adopts a classic fuzzy logic framework [10], so the I/P A is the sensor output for the channel under investigation and the I/P B is the maximum sensor output for either  $B_x$  channels up or down from the reference channel.

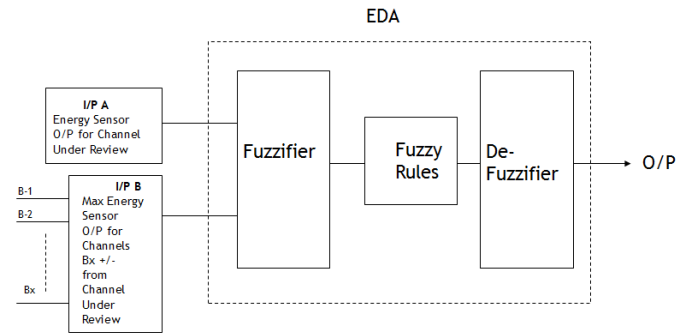

Figure 2 Enhanced Detection Algorithm (EDA) model

The fuzzifier translates the input into a fuzzy set which is allocated a membership function. This can follow any defined function within MATLAB, but in this scenario a normal probability function is used for RF detection.

The following five fuzzy rules are then applied to the two EDA input energy values, I/P A and I/P B (1 to  $B_x$ ) in Figure 2:

1. IF (I/P A) = unoccupied THEN (O/P) = unoccupied.
2. IF (I/P A) = uncertain AND (I/P B-2 to  $B_x$ ) = unoccupied THEN (O/P) = unoccupied.
3. IF (I/P A) = uncertain AND (I/P B-2 to  $B_x$ ) = occupied AND (I/P B-1) = occupied THEN (O/P) = unoccupied.

4. IF (I/P A) = uncertain AND (I/P B-2 to Bx) =uncertain AND (I/P B-1) = occupied THEN (O/P) = occupied.
5. IF (I/P A) = occupied THEN (O/P) = occupied.

Note, in rules 3 and 4, the interrogation of B-1 enables the EDA to satisfactorily resolve the scenario where there are strong adjacent noise components present.

These five rules uniquely govern the detection behaviour of the EDA in classifying the various channel energy measurements. The final block is the de-fuzzifier where a crisp output is produced using the *centre of area* method [11]. The de-fuzzifier output (O/P) follows a linear function, so 0 to 0.49 represents an *unoccupied* channel, while 0.5 to 1 reflects that it is *occupied*.

## 4 Test Models

The Test Models used had a generic specification and took the form of the model shown in Figure 3.

- i) The Noise Figure used for the DTV receiver was 7 and for the sensor 10 [5], [6].
- ii) The adjacent lower channel interference generator is formed by a 16 QAM transmitter simulating a 5MHz LTE interferer [4].
- iii) Gaussian noise is specified at -105dBm at a bandwidth of 8MHz.
- iv) Sensing time  $T = 50\text{ms}$

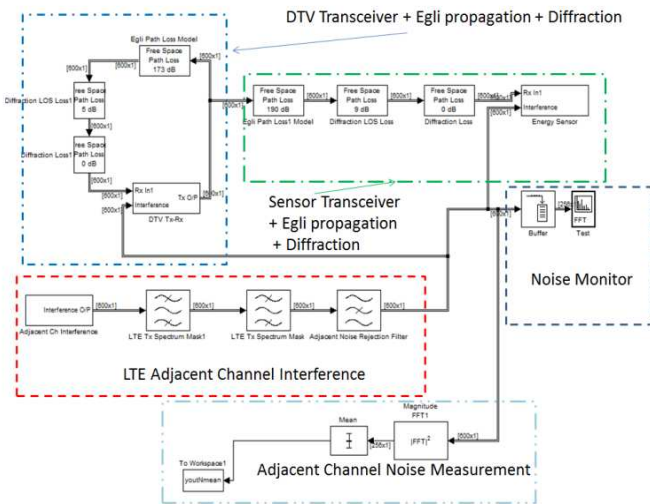

Figure 3 Test platform

The probability results were obtained by averaging the results over adjacent noise ranges and for 15 major DTV regions across the UK which have differing frequency deployment patterns, though all have 5 channels that use 64 QAM and 1 that uses 256 QAM modulation schemes.

## 5 Results Discussion

The following three experiments were conducted with a noise regime comprising a Gaussian noise floor of -105dBm and a lower adjacent channel interferer of between -400dBm to -28dBm. The DTV channel specifications are defined in [8] and [9].

The test platform used for the above experiment is shown in Figure 3 and was developed using Simulink with Matlab test scripts.

The first experiment examined the detection probability of EDA against distance, while the second and third series of experiments focused on transceiver bench testing strategy with results being averaged over the 15 major transmitter sites to aggregate the effect of the spectrum deployment patterns.

### 5.1 Distance versus Detection Probability

The detection performance of the EDA was compared with the two existing techniques [5] and [6] and a basic RF energy detector using the test platform in Figure 3. The experiments were performed for distances of between 60Km and 130Km for a transmitter power of 100KW.

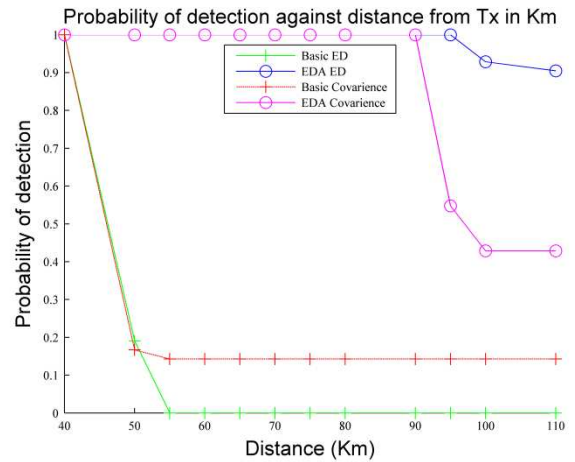

Figure 4 Detection probability plots

The corresponding detection results are plotted in Figure 4 which was based on a sensor placed in the Mendip transmitter region at a height of 1.5m. The detection probabilities were calculated by taking sensor readings over the range from 40Km to 110Km. The results clearly show the EDA algorithm outperformed the basic algorithm but no comparison can be made with [5] or [6] due to no distance experiments were documented for these DSA algorithms. By comparing the corresponding received *signal-to-noise ratio* (SNR) values at these two distances, from Figure 4 it can be seen a net 35dB SNR improvement has been achieved by EDA to corroborate

the rationale for applying fuzzy rules for channel allocation within the CLCE design.

### 5.2 Signal Strength versus probability of detection

The second series of experiments analysed the probability of detection against the incoming signal strength between -125dBm and -75dBm.

The motivation for these tests was to be able to compare the performance of the EDA against other algorithms in the study [5] which used signal strength as a reference. The sensor signal strength is attenuated by the ratio of the difference between antenna heights caused by reflection losses, though there is no diffraction parameters applied because the model is not based on a propagation model like Egli. The first set of tests used the signal strength against detection probability using the same noise regime has defined above. The results are shown in Figure 5.

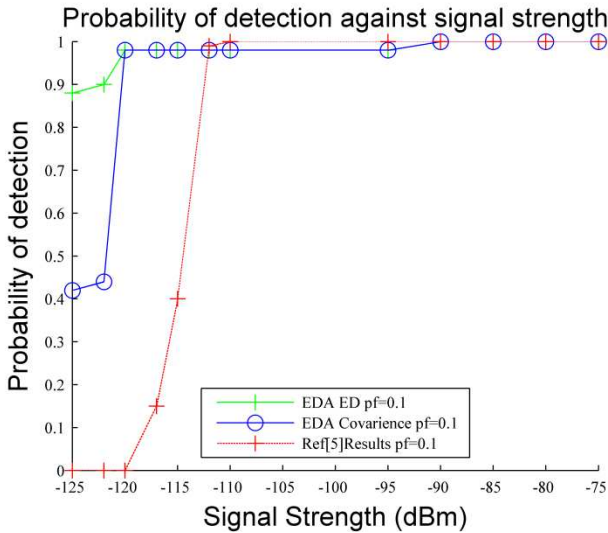

Figure 5 Detection Probabilities versus Signal Strength

The IEEE 802.22 specification [5] has been used for comparison with a detection probability threshold of 90% and a false detection rate of 10%, hence the parameter used is  $B_x=5$  from Figure 1.

The results for [5] in Figure 5 reveal a probability of 0.9 was achieved at -114dBm in contrast to the EDA using energy detector simulation which achieved -122dBm, so representing an improvement of 8dBm in signal strength. When comparing the EDA using the covariance detector an improvement of 6dBm is achieved, so overall only a 3dBm improvement was gained by the covariance detector compared with the energy detector

### 5.3 Probability of detection versus probability of false detection for different values of SNR

The third set of experiments sought to analyse the relationship between the detection and false detection probability against the SNR in the interval -22dB to -18dB. The tests analysed the EDA probability of detection against the false detection rate so that they could be equitably compared with [6]. The corresponding results are displayed in Figure 6.

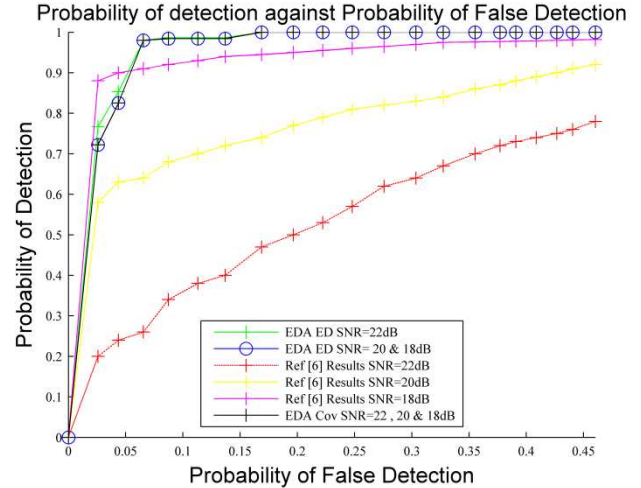

Figure 6 Probability of detection against probability of false detection for different values of SNR

The EDA results reveal a significant improvement over [6] due to the detection probability becoming certain i.e., 1 before the false detection rate achieves 0.24. In [6], this explicit condition is only achieved between 0.7 and 1 depending upon the SNR. Another interesting feature of the EDA is that it reduces the fluctuations in the detection and false detection probability with SNR as evidenced by the corresponding EDA results in the SNR range between 18dB to 22dB.

The corresponding results for the covariance detector EDA displayed no significant improvement over the energy detector EDA. However by analysing the computation complexity of the two models using the Halstead approach [13], it was found the covariance detector model was more than an order of magnitude higher in terms of complexity, than the corresponding Fourier-based energy detector.

## 6 Review of the Hidden Node Issue

This well-known problem [1, 2, 3] is caused by an unlicensed *secondary user* (SU) being shielded from the PU by an obstacle, so the sensor does not detect the PU. The SU then makes a decision to use the same channel to transmit, so causing interference to the primary receiver

This section investigates the impact on the EDA at  $B_x=5$ . The model assumed a distance of 30Km and 60Km respectively from the DTV transmitter with the obstruction buildings being 5m and 15m away from the sensor.



The obstruction heights were taken from a study on building heights and typologies in the Royal Borough London [11] which are categorised as: i) Typical height - 15m ii) Local landmark - 22.5m. iii) District landmark - 60m. iv) Metropolitan landmark - 90m. The corresponding results below characterise the EDA response in the presence of the “Hidden Node” issue.

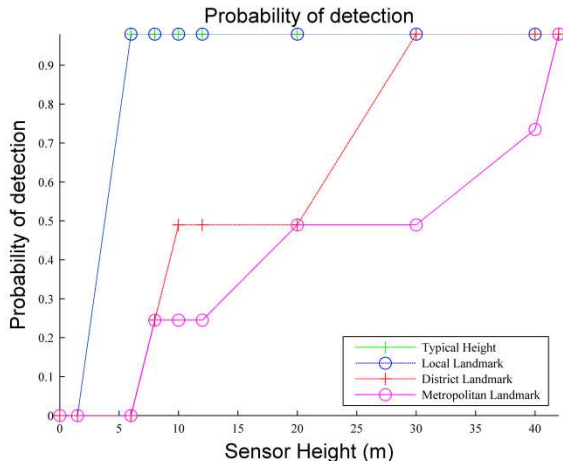

Figure 7 Probability of detection against sensor heights for different types of obstructions

From the results it can be observed that rural and small towns could be serviced from a sensor at a height of 6m which can for instance, be achieved by deploying lamppost TVWS cognitive devices. In contrast, for large towns and cities, sensor heights of 30m and 42m are needed respectively. It is evident from Figure 7 that the lowest sensor antenna height to obtain a detection probability of 1 is 6m which implies that a base station architecture is required i.e., sensor antenna height greater than 1.5m. When the building category increases in height so does the required sensor antenna height so mobile sensors are unable to operate in any category and distributed sensors at differing heights are required to ensure PU information can be distributed to all users.

## 7 Conclusion

This paper has shown that an *enhanced detection algorithm* (EDA) consistently out performs existing PU detection algorithms when applying the IEEE 802.22 WRAN standard of 90% for detection and 10% false detection thresholds. In comparing the covariance detector with the energy detector there was negligible improvement gained for the added complexity incurred, so the overall conclusion is for an energy detector to be used with the EDA.

This paper has demonstrated that a sensing strategy is feasible for TVWS applications and with the further study outlined to gain detection probabilities of 100% will start to persuade the regulatory bodies to re-think their geo-location database decisions. Further work is intended to enable the EDA to be adaptive and achieve the detection probability of 100% in all circumstances.

When the “hidden node” issue was examined it was seen that when a sensor height of 1.5m (mobile sensor) is used the probability of detection is very limited and only becomes feasible for heights at 6m or more. Indeed in large cities the use of distributed sensors on top of buildings would have to be considered.

## References

- [1] Nekovee M. (2010), Cognitive Radio Access to TV White Spaces: Spectrum Opportunities, Commercial Applications and Remaining Technology Challenges’, IEEE DySPAN, pp 1—10
- [2] Nekovee M. (2011), Current Trends in Regulation of Secondary Access to TV White Spaces Using Cognitive Radio, IEEE Globecom, pp 1—6
- [3] Martin JH, Dooley LS, Wong KCP, (2011), A New Cross-Layer Design Strategy for TV White Space Cognitive Radio Applications, IEEE IWCLD, pp 1—5
- [4] Cambridge White Spaces Consortium 2012, Cambridge TV White Spaces Trial, A Summary of the Technical Findings [online], <http://www.cambridgewireless.co.uk/docs/Cambridge> accessed 20<sup>th</sup> April 2013
- [5] Lei Qiu Jing C, Viessmann A, Kocks C, Bruck GH, Jung P, Qingyang Hu R ,(2011), ‘A Spectrum Sensing Prototype for TV White Space in China’, IEEE Globecom , pp 1—6
- [6] Chen H-S, Gao W (2011), ‘Spectrum Sensing for TV White Space in North America ’, IEEE Journal on selected areas in communications, VOL. 29, No. 2 , pp 1—11
- [7] Akyildiz IF, Lee W-Y, Chowdhury KR (2009), ‘CRAHNS: Cognitive radio ad hoc networks’, Network IEEE, Vol.23 (4), pp 6—12
- [8] Seybold JS (2005), Introduction to RF Propagation, Wiley, ISBN-10 0-471-65596-1
- [9] Ofcom (2011) Digital Switchover Transmitter Details [online], Ofcom, <http://www.stakeholders.ofcom.org.uk/broadcasting/guidance/tech-guidance/dsodetails/> (Issue 4.0 Jan 2011), accessed 23<sup>rd</sup> Feb 2013.
- [10] UK Free TV (2013) Freeview: Full service Freeview transmitters [online], UK Free TV, <http://www.ukfree.tv/txlist.php> (2013), accessed 23<sup>rd</sup> Feb 2013.
- [11] Baldo N , Zorzi M (2008) ‘Fuzzy Logic for Cross-layer Optimization in Cognitive Radio Networks’, Communications Magazine, IEEE, pp 64—71
- [12] The Royal borough of Kensington and Chelsea Council (2010) ‘Building Height in the Royal Borough– A Supplementary Planning Document, pp 16 - 20
- [13] Loeffler WHT , Wegener J ,(2012), ‘Quality Model based on ISO/IEc 9126 for Internal Quality of MATLAB/Simulink iStateflow Models’, IEEE Xplore , pp 325—330