



# Open Research Online

---

The Open University's repository of research publications and other research outputs

## Improving overlapping between testing and design in engineering product development processes

Conference or Workshop Item

How to cite:

Tahera, Khadija; Earl, Chris F. and Eckert, Claudia (2013). Improving overlapping between testing and design in engineering product development processes. In: ASME 2013 International Design Engineering Technical Conferences (IDETC) and Computers and Information in Engineering Conference (CIE), 4-7 Aug 2013, Portland, Oregon, USA.

For guidance on citations see [FAQs](#).

© 2013 ASME

Version: Accepted Manuscript

Link(s) to article on publisher's website:

<http://www.asmeconferences.org/IDETC2013/index.cfm>

---

Copyright and Moral Rights for the articles on this site are retained by the individual authors and/or other copyright owners. For more information on Open Research Online's data [policy](#) on reuse of materials please consult the policies page.

---

[oro.open.ac.uk](http://oro.open.ac.uk)

**DETC2013-12913**

**IMPROVING OVERLAPPING BETWEEN TESTING AND DESIGN IN ENGINEERING  
PRODUCT DEVELOPMENT PROCESSES**

**Khadija Tahera**

The Open University  
Milton Keynes, UK  
Khadija.tahera@open.ac.uk

**Chris Earl**

The Open University  
Milton Keynes, UK  
Chris.earl@open.ac.uk

**Claudia Eckert**

The Open University  
Milton Keynes, UK  
Claudia.eckert@open.ac.uk

**ABSTRACT**

Testing components, prototypes and products comprise essential, but time consuming activities throughout the product development process particularly for complex iteratively designed products. To reduce product development time, testing and design processes are often overlapped. A key research question is how this overlapping can be planned and managed to minimise risks and costs. The first part of this research study investigates how a case study company plans testing and design processes and how they manage these overlaps. The second part of the study proposes a significant modification to the existing process configuration for design and testing, which explicitly identifies virtual testing, that is an extension to Computer Aided Engineering which mirrors the testing process through product modelling and simulation, as a distinct and significant activity used to (a) enhance and (b) replace some physical tests. The analysis shows how virtual testing can mediate information flows between overlapping (re)design and physical tests. The effects of virtual testing to support overlap of test and (re)design is analysed for the development phases of diesel engine design at a case study company. We assess the costs and risks of overlaps and their amelioration through targeted virtual testing. Finally, using the analysis of the complex interactions between (re)design, physical and virtual testing, and the scope for replacing physical with virtual testing is examined.

**INTRODUCTION**

Increasing product complexity, increased warranty costs, growing competitive cost pressure all drive the need for rigorous and improved testing process. To be successful in competitive markets, performance, reliability, safety and durability are also critical issues. A potential design may fail to meet customer requirements, have technical design faults, or raise issues about manufacturability and maintainability [1, 2]. Testing can identify these problems and is central to the product development process (PDP) [3]. However, physical testing can take a long time, and delayed or negative results in one phase

potentially jeopardise project schedules, as test necessitate design changes and re-tests.

Ideally, the upstream design should be tested and the results of these testing should drive the downstream design. As physical testing is lengthy, design for the next phase often starts before testing is complete, causing testing and design activities to overlap. Overlapping testing and design activities can incur risk, since redesigning without test results might perpetuate faults or miss opportunities to respond to emerging problems. This paper looks at a particular situation where most changes occur towards the end of a long duration testing (ie slow evolution) and where substantial redesign results from these changes (ie high sensitivity). The literature [4] suggests that overlap models of product development do not apply well in this situation.

This paper proposes modification to the PDP structure which identifies a more prominent role for virtual testing (ie the extension of Computer Aided Engineering to mirror physical testing) which can allow overlap between design and testing to be more effective.

**BACKGROUND**

Typically the cost of testing can consume up to 50% of total development cost [1]. In the spacecraft and satellite industry, system level integration and testing (I&T) alone costs approximately 35-50% of total development resources [5]. In the software industry testing can consume fifty percent or more of the development costs [6]. In response to time-to-market pressures, engineers aim to improve physical testing to get more value out of planned testing without adding time and cost to the development process. Therefore planning and sequencing of tests in the PD process is a critical issue.

Testing is widely recognized, both in research and industry practice, as a key part of the PD process. Although there is some literature addressing how to plan testing efficiently during the PD process by [1, 7-10], testing does not receive the same attention as other activities in the PD process in the academic

literature. Some papers allude to testing in the context of general product development and briefly outline its relevance [8, 10].

To reduce the development time companies often overlap tasks. Overlapping occurs when a downstream task is started before completing upstream tasks. In general, the advantage of overlapping has been recognized in several studies [4, 11-13]. Clark and Fujimoto [11] suggest that optimal overlapping may depend on organizational characteristics and effective communication. Overlapping might identify design flaws [12], but may allow accidental omission of key steps [6] and may introduce uncertainties which can increase iterations [7]. In the worst case, development costs may increase and product quality may degrade [4].

Engineering companies overlap testing and design as essential practice. Very limited work on overlapping testing and design activities has been done. Recent work by Qian, Y. et al. [1, 2] and Lin, J. et al. [14] presents analytical model of testing strategies and overlapping policies.

Two studies are particularly relevant in setting the context and background for this research. First, Krishnan et al. [4] develop a model which formalizes the tradeoffs based on two key concepts: upstream evolution and downstream sensitivity. If the primary information about a product's parameter values are given as intervals, as the product development progresses the intervals are narrowed and finalized, some faster than others. When the process fast approaches towards the final values and can achieved early in the process this is called fast evolution, whilst slow evolution occurs if most design changes happen towards the end. In low downstream sensitivity, substantial changes in the upstream tasks can be accommodated rapidly in the downstream activities. High downstream sensitivity happens when small upstream changes require large amounts of iteration in downstream activity. This analysis concludes that in general a fast evolution and low sensitivity situation is favorable to overlapping, and conversely, high sensitivity and slow evolution is less favourable.

Second, Terwiesch and Loch [15] present a statistical measurement of the effectiveness of overlapping development activities in reducing project completion time. Fast uncertainty resolution projects benefit from overlapping. This is similar to Krishnan's conclusion above. Terwiesch and Loch [15] also identify that testing in projects with fast uncertainty resolution seems to have a delaying rather than an accelerating effect. These conclusions might imply that testing with long lead time and slow uncertainty resolution is not favorable for overlapping test with redesign unless accompanied by structural changes in the product development process.

Because of the increasing cost of physical testing (particularly in fuel for the case study) companies are also anxious to learn the most from a test and to minimize the number of iterations in physical tests. This paper proposes modifications to the structure of design and testing processes which allow effective overlap for fast evolution and low sensitivity. The benefits of overlapping can then be realized more widely in practice with careful organization of virtual testing.

## METHODOLOGY

This research is based on a case study in a UK-based company that designs and manufactures diesel engines. Diesel engines are complex, incremental, highly regulated products with high levels of testing to meet customer requirements, performance standards and statutory regulations. Fifteen interviews were carried out, recorded and transcribed, between March 2011 to September 2012 with six engineers: a senior engineer, a development engineer, a CAE engineer, a verification & validation manager and a validation team leader.

Multifaceted overlapping activities were observed in the company, but this study focused on single layer overlapping. There were two main objectives:

1. To identify a means of effective overlap, even where the upstream evolution of information is slow and downstream sensitivity is high.

To identify ways to speed up testing to give quicker uncertainty resolution.

## A CASE STUDY: TESTING ACROSS THE PRODUCT DEVELOPMENT PROCESS

The case study company has a structured gateway process for New Product Introduction (NPI) (Figure 1). It has eight stages starting from "Launch" to "Gateway 7". Most of the testing occurs between Gateway 2 (GW2) to Gateway 4 (GW4), thus this research focuses on these three main phases of the PD process (as in Figure 2).

Among the large number of activities in these stages, Re/Design, Computer Aided Engineering (CAE) (e.g. Simulation), and Procurement (of test prototypes) are considered as drivers for testing. For simplicity Figure 2 presents these activities as time limited boxes, but in reality, a core team keeps working on Design and CAE, and Testing goes on almost continuously, in parallel to these activities. Design, CAE, Procurement and Testing undergo at least three iterations from GW2 to GW4, and serve different purposes in each stage.

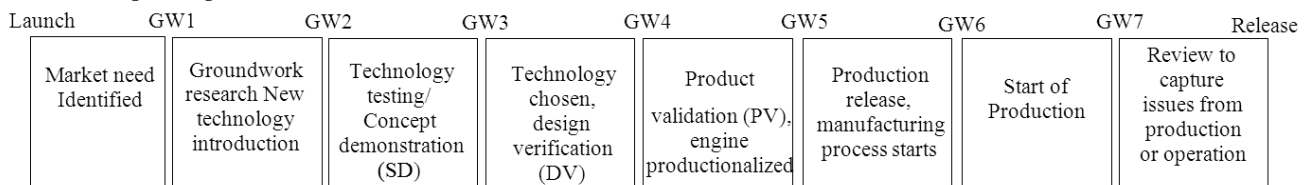
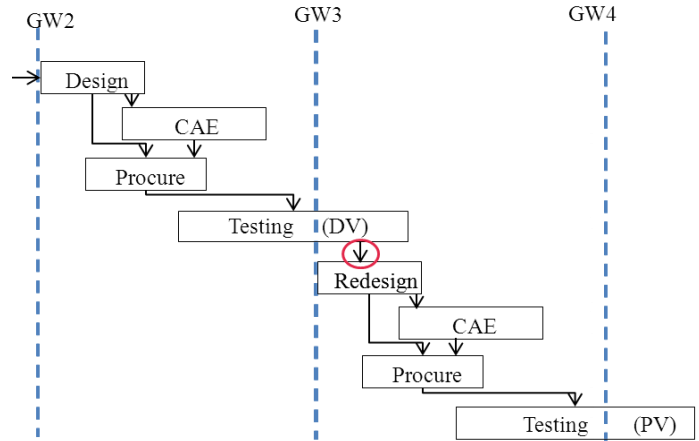

Figure 1 AN OUTLINE OF THE COMPANY'S GATEWAY PROCESS

Three phases of testing are distinguished: (i) Concept/System Demonstration (SD) shows that the technology can deliver the required performance; (ii) Design Verification (DV) aims to ensure that design outputs meet the given requirements under different use conditions, and (iii) Product Validation (PV) which tests the product against customer requirements and specifications, e.g. under a range of potential use. Both the product's characteristics: Performance and Emission (P&E) and the mechanical durability and reliability are tested in each of the three phases. The mandatory tests required for acceptance from customer or regulation, usually occur during PV phases. The testing blocks, in Figure 2, contain a large number of tests. Some tests are grouped and some are individual. Some test results can be obtained quickly whereas some require running the tests till very end of the testing phase.



**Figure 3 OVERLAPPING BETWEEN TESTING AND REDESIGN IN TWO PHASES**

### Long lead-time for procurement

In some cases, for example during design verification (DV), when the company needs to start the test to meet the schedule of the next GW stage, important hardware component might not be available from the supplier. The company cannot afford delay, and instead tests using alternative off-the-shelf components or makes the prototype components in different ways, e.g. machine a component that later will be cast. The validation managers identify suitable alternatives and calculate trade-offs. For example, to test the cylinder head, which will not be delivered until later, the engineers will either continue physical tests with a prototype cylinder head or simulate the engine computationally and identify the associated risk. These alternative tests may provide planned risk reduction. In this scenario the product cannot be signed off yet, and physical testing of the cylinder head is still necessary for verification. This situation causes the DV or PV phases to extend over two GW stages instead of one.

### Lengthy physical tests

As lengthy procurement time disturbs the process and since testing takes a long time, often the DV phase testing may still be on-going while the (re)design for the PV phase is started and while procurement for the subsequent PV testing begins, as seen in Figure 3. Without the testing results being available, there will be uncertainties in redesigning and procuring for the next phase. This is a case of slow evolution of testing results, which might have high sensitivity in the downstream design phase, and can result in an increased number of iterations in subsequent phases.

The company is counteracting these problems with two main strategies: (a) providing accurate specification to the supplier through CAE analysis and (b) reducing the effort needed for physical testing through carrying out as many virtual tests as possible by simulation in extended their CAE models.

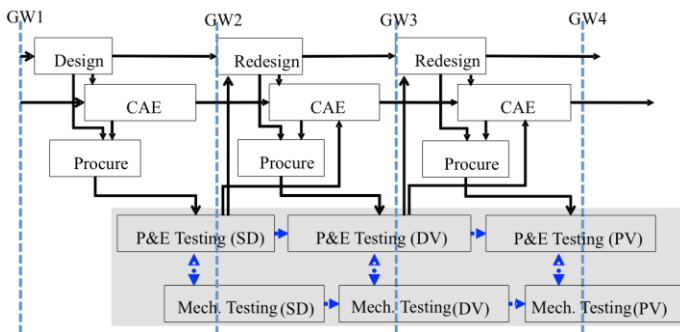

**Figure 2 A SCHEMATIC OF THE PD PROCESS FROM GATEWAY 2 TO GATEWAY 4**

Figure 2 illustrates how engines are tested in sequence for SD, then DV and PV. However, in reality, several versions of the same engine are tested simultaneously in parallel test-beds, where each bed replicated a particular set of specifications. Some components are tested for concept demonstration whereas others are tested for design verification. Therefore, each testing phase overlaps in a complex manner. Note that the significant overlaps which occur between testing and (re)design of next phase, is an area of interest of this paper.

### OVERLAPPING BETWEEN TESTING AND DESIGN

In analyzing the company's design and testing processes, long lead time for procurement and the long duration of physical tests become clear as pertinent issues. We considered a lengthy test, namely, the 'gross thermal cycle' which is a 1000 hour endurance test (equivalent to 2 months on a test bed) which ascertains if the cylinder head will endure repeated gross thermal cycling without cracking. Engineers need to allow 3 months to procure the components and a month to prototype building and post-processing. In total six months are required to complete this test and develop a finished component specification.

## ROLE OF COMPUTER AIDED ENGINEERING IN THE PD PROCESS

CAE is playing a significant role in the company's design process. One engineer commented, "CAE is becoming increasingly important to the companies to minimize the effort and expense involved in product development". In the case study company, design processes begin with mathematical models of the target performance which are increasingly expanded as more and more factors are included in the models as part of a requirements cascade [16]. The initial performance models are run by the Computer Aided Engineering (CAE) team. The geometry of the components is designed around these performance models by component teams and later handed back to the CAE team for validating through Computer Aided Engineering (CAE) tools like FEA and CFD. The models are further refined to simulate load cycles, loading locations, sensors locations, sensor and system calibrations etc. as an input to the test engineers. As illustrated in Figure 4, this is a continuous development of computer models, but with a distinctly different purpose.

In this case study company, CAE analysis typically falls into three main areas: structural analysis, mechanism or dynamic analysis and thermo-fluid-flow dynamics, results in making assumptions and determining the parameters like material properties, geometric idealization, and physics. These analyses also identify an initial set of boundary and operating conditions, which can be compared to the product requirements and improved in design iteration. A supplier's design analysis and testing data also provides information in setting the boundary and operating conditions. For this company, CAE simulation is formally required before releasing the design to suppliers. As CAE confirms the design, the suppliers are informed.

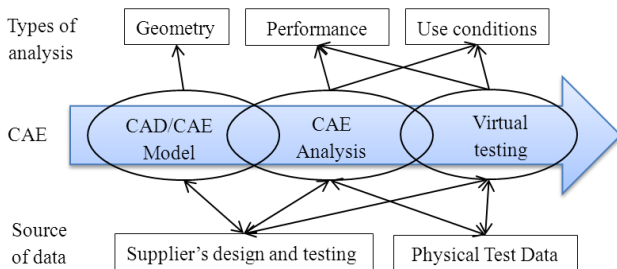

**Figure 4 PROGRESS OF CAE IN EACH GATEWAY STAGE**

In earlier stages of the PDP, the CAE analysis confirms whether a design meets the customer specifications and requirements. It helps define the scope of the design activity. The company uses CAE analysis to: a) meet the design parameters, b) explore the opportunities by varying the parameters and c) support earlier design decisions.

Further analysis and simulation is performed to identify the behaviour of the components in response to those conditions. We refer to this type of CAE as *virtual testing*, because it simulates attributes which are tested in physical tests. One

senior engineer mentioned "our virtual testing is all about simulating the test conditions, which is our history of knowing that the product worked".

Initial CAE analyses narrow down the boundary conditions and provide specific information to the physical test engineers. For example in a performance test, simulation can predict when to measure a value or conditions, so less time is spent on the physical test. In conventional methods for designing a test setup for a mechanical product, test engineers used the best practices, experiences, and expertise to determine methods and objectives. However, in recent years, significant improvement in CAE analysis can now provide load cycle, loading locations, sensors locations, sensor and system calibrations, for example, to the test engineers.

As physical testing happens under a specific set of conditions, the testing data does not provide information where the product will fail next or if the load was slightly higher, whether the product would have failed. Test results cannot even predict whether a part will break at the same place given another sample build with material properties or dimensions, but at a different place in the tolerance range. In simulation, the engineers can systematically vary these scenarios, by changing the environmental conditions, feature size and operational values. And the cost and time required for these iterations is considerably lower than the physical testing. As the case study company produced engines for different applications and operating conditions the product needs to be tested in each application. Multiple iterations in physical testing to cover the whole range of applicability can be prohibitively costly. Therefore the company uses virtual testing to explore the design parameters and the variability of manufacturing parameters, which is not possible in physical tests.

In summary virtual testing is performed to: a) understand the behaviour by varying the environmental and operating conditions, b) to set-up physical test conditions, input parameters and sensors locations and c) to assist physical testing.

## PROPOSED METHOD OF PARALLEL PHYSICAL AND VIRTUAL TESTING

In the background section, two key papers [4, 15] were identified. Krishnan, V. et al. [4] recommend circumstances where activities should be overlapped. From their model, the worst case is where the upstream evolution is slow and the downstream sensitivity is high; in this case overlapping is not recommended. In this situation, it is suggested that exchanges of information should be disaggregated, to see if any information can evolve faster, or can be practically transferred in a primary form.

On the other hand, in another key paper, Terwiesch and Loch [15] indicated that lengthy testing might have a delaying effect on a fast uncertainty resolution project. For this case study company, it is difficult to gauge the speed of uncertainty resolution. The company has to finish a project on a given timeline and bring the product to the market. Even for a complex new product, the timeline may vary little. Terwiesch

and Loch [15] also suggest that “if the uncertainty resolution over the course of the project is unfavourable for overlapping activities and cannot be sufficiently accelerated by defining standards and architectures, the project organization has to search for other means of uncertainty resolution” [15]. For the case study company, testing is the primary method for uncertainty confirmation and identification. Subsequent tasks such as redesign are ‘uncertainty elimination’ tasks. Knowing the associated risk of an extensive rework, the company has no choice but to overlap these design tasks with testing, and a design proposal is needed to commence another lengthy procurement process. Thus for this case, a way of accelerating the testing process was critical.

**Information evolution and deviation from target value**

Before going into the details of the proposed method, first we discuss the concept of “evolution” and “deviation from target value”, and next we illustrate the process of parallel virtual and physical testing to improve the testing process.

**Information evolution.** The idea of evolution is introduced by Krishnan et al. [4]. The term evolution is described as the rate at which information is progressed from the start of an activity through the completion of the activity. At the beginning of the testing, initial interval  $\{a_{in}, b_{in}\}$  (as in Figure 5) of the parameter X, is known to the engineer. As the testing process progresses engineers aim to know more about the actual value of the parameter. Usually the test team records the data stream from the physical set up at several set points as the physical testing progresses. For example, in a “gross thermal cycle” test, the measurements are recorded every day. By analysing this data, engineers can identify the true behaviour of the product and gain a better understanding of the product. Therefore, as the testing process progresses, measurements provide more information about the parameter and the interval width decreases, meaning that the value of the parameter gradually narrowed down to a final value [4]. Engineers keep learning about the parameter and the changing behaviours throughout the testing process; however the final values of the parameter are known at the end of the testing process.

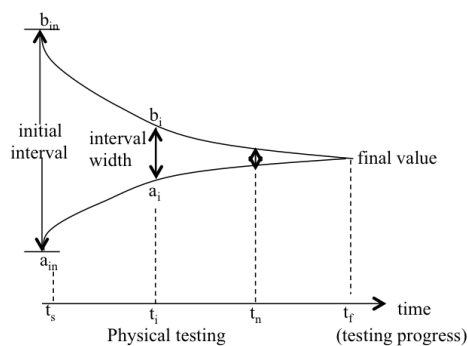

**Figure 5 INFORMATION EVOLUTION OF A TESTING PROCESS TO FIND THE FINAL VALUE OF A PARAMETER (ADOPTED FROM [4])**

The likelihood of finding faults through a test is a bifocal distribution with many faults showing up early in the test and others towards the end. However, the state of the system or its components can only be assessed once a test is completed. While a test might not fail as such, the state of particular components might not be acceptable and require redesign.

**Deviation from target.** Figure 6 shows, the physical testing process starts at  $t_s$  and finishes at  $t_f$ . As design is accomplished with the best knowledge of that stage, at  $t_s$ , it is assumed that the design meets the target. As the testing process progress, any deviation in design from the target is identified. The changes in measurements at  $t_1$  and  $t_2$  identify the deviations. For simplicity of the model we are assuming that the deviation function is monotonic. As the testing process progresses and the information evolve, the interval width (as shown in Figure 5) of the parameter decreases. Testing also identify how much a design deviated from target. At the end of the process, at  $t_f$ , testing reveals the final value of the parameter, and how much it deviates from the target, so that design can be improved in redesign.

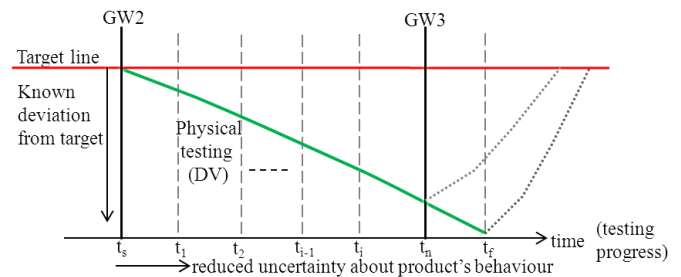

$t_s$  = ideal start time of design(PV) with final test results  
 $t_n$  = company's planned start time of design(PV) with intermediary test measurements  
 — Physical testing (DV)

**Figure 6 THE PROCESS INFORMATION EVOLUTION AND IDENTIFYING DAVIATIONS FROM TARGET THROUGH PHYSICAL TESTING**

Ideally, at  $t_f$ , after finishing the downstream testing, upstream design tasks should start so that the final value of the parameter and any deviation from the requirement is known. However, at  $t_n$ , the company is forced to start design for PV to meet the schedules of GW4. At  $t_n$ , the company relies on intermediary test measurements and use past experience to make assumptions of the final value of a parameter. Any prediction of the final value is largely uncertain if a lot of changes in the value of the parameter (i.e. evolution) happen after  $t_n$ . Any uncertainties in measurements and assumptions might require considerable rework in design. Also if a small change in the value of the parameter can cause significant downstream design work - thus increasing duration - then the parameter is considered to have high sensitivity [4].

A major challenge to the company is to reduce the length of a physical test so that physical testing can be finished in

schedules at  $t_n$ , or if not, to predict the final value of a test at this point with reduced uncertainty. The implication is that the downstream design should not suffer significant rework. We propose that the uncertainty in predicting the final value of the parameter can be reduced with the use of virtual testing which takes place in parallel to physical testing.

### A method of parallel physical and virtual testing

A physical test can only be assisted with virtual testing if a virtual test is created and validated accurately. The proposed method of virtual model validation depends on several conditions: a) the supportive virtual model is modelled accurately, b) the model is calibrated and validated accurately with practical test measurements, and c) necessary and sufficient measured values gathered to have confidence in test measurements.

A process of predicting the final value of the parameter at an earlier point through parallel physical and virtual testing happens in two steps: 1) virtual model is calibrated and validated through physical test measurements and 2) the prediction of final test results through simulation as is presented in the next section.

#### Step 1: CAE model is calibrated and validated through physical test measurements

Initially a virtual testing can vary from a physical testing for several reasons: 1) theories or assumptions are not right, 2) the virtual model is not created accurately and 3) the model is not validated or calibrated due to lack of practical data. As company's virtual models are founded on the years of expertise of engineers and the software development team, the team has the expertise to formulate mathematical models for the interacting engine components, write appropriate numerical solution algorithms, and integrate the resultant programs into workable analysis. Therefore, the variations in simulated and physical testing results can be minimized by accurate virtual modelling and validating the model with practical physical test data.

To create a virtual model for test, engineering experience, prior understanding of the product, previous product testing and historical data should all contribute to the model for virtual test. However, new requirements and use conditions may question if the model has been created accurately with the previous product information. Therefore the model might require modifying against the values gained from the current physical tests.

Consider Figure 7. At  $t_s$ , the assumptions of the virtual model are based on previous product and historical data. As mentioned earlier, the company takes measurements from physical tests at several set points for example at  $t_1, t_2, \dots, t_n$  and so on. At  $t_1$ , the physical test provides the first measurements of the parameter, which are the practical values of the current product under test. These measurements are available to compare with the simulated results. The virtual model is adjusted according to these measurements. These measurements can also indicate the product's behaviours and

consequently the type of analysis that is required, for example, linear or nonlinear. Therefore, the virtual model is adjusted and improved according to these measurements.

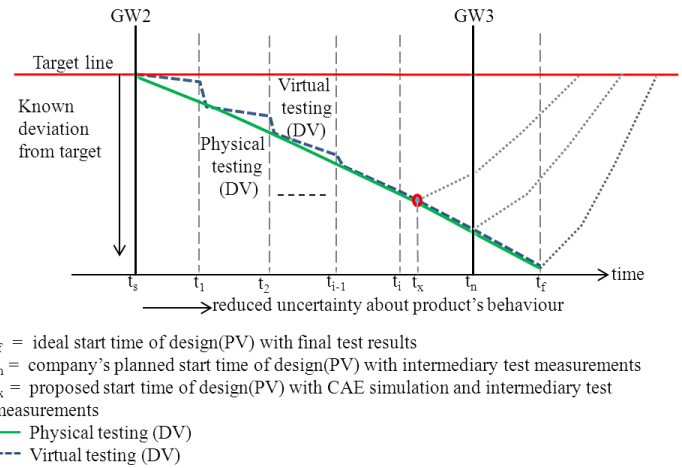

**Figure 7 PARALLEL EXECUTIONS OF CAE SIMULATION AND PHYSICAL TESTING TO START SUBSEQUENT DESIGN TASKS EARLIER**

Further simulation of the virtual model produces the values according to these measurements and can be compared again with the next test measurements at  $t_2$ . Any variations in simulated results will be adjusted according to test results. This process could directly, point-to-point, help calibrate and verify the results of the simulation. In a number of iterations, the virtual model will be adjusted until the simulated results are representative of the physical test results. Let's assume, at  $t_i$ , simulation predicts the testing measurements accurately. At this point, virtual model is calibrated and validated with the current test measurements.

A decision about a parameter can only be taken when the interval width (as shown in Figure 5) is reduced down to a accepted point, meaning that the test needs to be running for certain amount of time to produce useful results, to predict the behaviour and value of the parameter. For example, engineers can gather enough data and can be confident on test measurements at  $t_i$  (as shown in Figure 7). Therefore, engineers also need to take a decision whether virtual model is validated and calibrated with the necessary and sufficient test measurements. At a point, say  $t_{i-1}$ , the virtual model can produce the physical test measurements accurately. However the engineers might find that the test measurement data is not sufficient to validate the virtual model yet. So they might require a wait until a point where sufficient and necessary data available to calibrate and validate the virtual model. At that point simulation using the model is predicting the test measurements accurately. Both points meet at  $t_i$ , for example. At this point, the virtual model is validated and calibrated with sufficient and necessary practical data. Further validation and calibration of the virtual model through measurements of physical tests needs to be continued.

*Step 2: The prediction of final test results through simulation to start downstream design*

Simulation runs faster than the physical tests. Therefore, after the point  $t_i$ , once the virtual model is validated, it should simulate the test measurement faster than the physical test at a point  $t_x$ . The virtual model could simulate the rest of the physical test and could predict the values of time  $t_f$  and any deviation from target, at an earlier point, for example at  $t_x$ . In this way the uncertainty about the prediction of a final value of parameter X at an earlier point will be reduced.

Often engineers cannot predict the test results because tests are often aggregated and run for a longer period of time. As virtual tests are created to analyse individual tests and are more controlled, the information from tests can, if required, be disaggregated into cycles of a specific test for example. This can also support the engineer's decisions.

If the uncertainty in predicting the results of upstream tasks can be reduced then the downstream tasks can be performed more accurately. Therefore rework in downstream tasks will be reduced accordingly. Thus the company can start subsequent design tasks for next phase with a simulated test result which will provide better accuracy than just predicting the value. Therefore the rework in design is likely to be reduced.

**THE IMPLICATION ON DURATION AND COST**

In this section we analyse how the proposed model might affect the time and cost of testing and design process. First we describe the notations and conditions of overlapping to set up the background and next consider an example.

We are considering that upstream testing and downstream design tasks durations are  $d_t$  and  $d_d$  respectively (see Figure 8). Where the downstream design starts after finishing the upstream testing and overlapping is not applied, the total

duration of these tasks is  $D_n = d_t + d_d$ . When the overlapping is applied the duration is,  $D_o = d_e + d_d + d_x$ , where  $d_e$  is the elapsed time between starting time of upstream testing and starting time of downstream design,  $d_d$  is the downstream design duration and addition rework in design duration is  $d_x$ , as in Figure 8(b). Overlapping will only be beneficial when  $D_o < D_n$ .

In an overlapping process, downstream design can start any time after upstream testing measurements are available and before finishing the upstream testing, thus  $d_e < d_t$  and  $d_e \neq 0$ . As downstream design starts with preliminary test measurements, some of the design work might require reworking when upstream testing results changes. The duration of rework is  $d_x$ . Downstream design and rework cannot finish before finishing the upstream testing, as all testing results needs to accommodate in design, therefore  $D_o > d_t$ . Time saving through overlapping is:  $D_n - D_o = d_t - (d_e + d_x)$ . This equation shows that overlapping will provide better time saving with smaller duration ( $d_e + d_x$ ) and need to maintain the condition of overlapping  $d_t > (d_e + d_x)$ . The condition  $D_o > d_t$  also provides that  $d_t > (d_e + d_x) > (d_t - d_d)$ , considering that physical testing takes longer than the design tasks. Therefore, the condition that needs to maintain to be beneficial through overlapping is:

$$(d_t - d_d) < (d_e + d_x) < d_t \tag{1}$$

Delaying the start of downstream design, thus increasing the  $d_e$ , will allow accumulating more upstream testing results in downstream design, which means less time might require in reworking. Therefore,  $d_x$  tends to decrease with the increase of  $d_e$  (as shown in Figure 9).

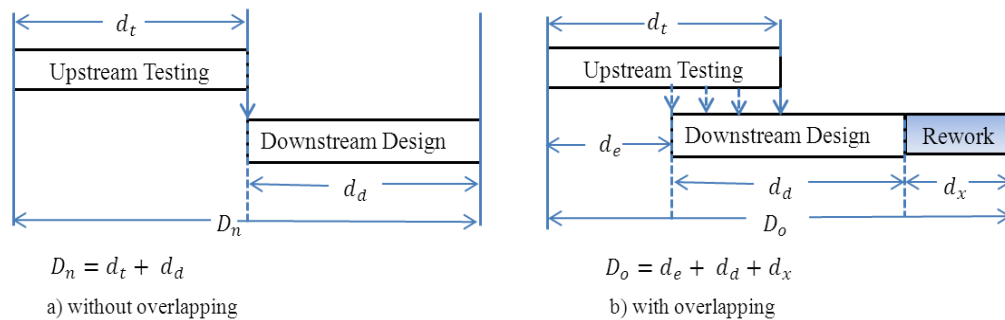

- $d_t$  = duration for upstream testing
- $d_d$  = duration for downstream design
- $d_e$  = time different between starting of upstream testing and starting of downstream design
- $d_x$  = duration for reworking in design due to overlapping
- $D_n$  = duration for completing testing and design without overlapping
- $D_o$  = duration for completing testing and design with overlapping
- $\rightarrow$  = preliminary information
- $\Rightarrow$  = final information

**Figure 8 CONCEPTS OF OVERLAPPING AND NOTATIONS**



With recent improvements in CAD and CAE tools, design changes and analysis of design can happen in a shorter time. Therefore the sensitivity of the downstream design,  $d_x$ , can be minimized through CAE analysis. The downstream design sensitivity can also be minimized through the effective communication between test engineers and design engineers. Other factors like such as, the products' modularity, robust design, and anticipation by downstream designers for changes in upstream information, can all help reduce the sensitivity of downstream design [4].

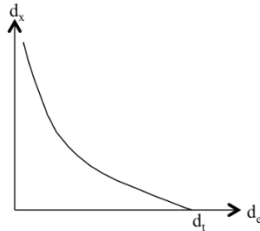

Figure 9 RELATIONSHIP BETWEEN  $d_e$  AND  $d_x$

**Changes in durations with parallel virtual testing**

An example of a lengthy critical test endurance which checks the fatigue resistance of the cylinder head was considered in order to study how the behaviour of  $d_e$  and  $d_x$  could change when supported by virtual testing. To maintain the confidentiality of the company all the durations in this paper has been changed to a proportion accordingly. The length of the endurance test  $d_t = 8$  weeks, and downstream design  $d_d = 2$  weeks. According to equation (1) the boundary for  $(d_e + d_x)$  stands as:  $6 \text{ weeks} < (d_e + d_x) < 8 \text{ weeks}$ . This means any decision about overlapping can be taken after 6th week.

We discussed with an engineer and recorded how the behaviour of  $d_e$  and  $d_x$  will be observed in a regular case. This is shown in Figure 10(curve a). Engineers identified previously that the test doesn't produce any significant results during the first 4 weeks and most of the fatigue of the components starts to appear towards the last two weeks of the test.

Test measurements in the first four weeks will not be enough to validate the virtual testing model. After the fourth week of the test, the engineers will be able to use test measurements combined with historical data to virtually model the behaviour of the component under test. The virtual model can be validated using the next measurements which are taken daily in this test. Therefore, the simulation of the test can be used to predict the physical test results after 5th week. To run a simulation will take a day at maximum. Therefore the subsequent design can be started after 5th week.

We also discussed the potential of using virtual testing and how this might affect the behaviour of  $d_e$  and  $d_x$ . This is shown in Figure 10(curve b). After four weeks the physical test starts to produce enough data to validate the virtual model, thus up to this time (28 days), virtual testing will not be used. Therefore the time required,  $d_x$ , will be same in both cases. After the fourth week, the virtual model will be calibrated and validated with the physical testing data in several iterations. Thus it can

be assumed that the virtual model will be capable of simulating the test after 5<sup>th</sup> week.

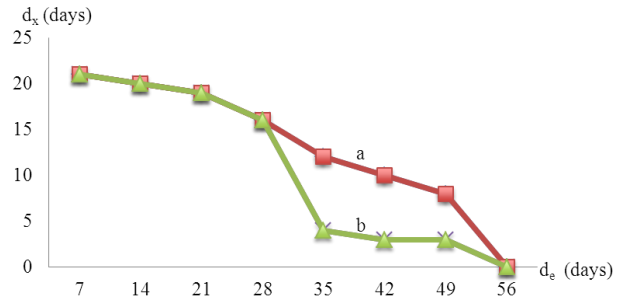

Figure 10 THE CHANGE IN BEHAVIOUR OF DE AND DX WITH USE OF VIRTUAL TESTING

By providing accurate data, the design might not suffer substantial rework. Learning from the parallel virtual testing will reduce the uncertainties in design and procurement. Virtual testing of one phase also assists the CAE analysis of next phase. As design is assisted by CAE analysis, any changes in design can be done in considerably shorter time. Therefore the duration in downstream design rework,  $d_x$ , can be reduced substantially with the proposed addition of virtual testing.

**Costs for introducing parallel virtual testing**

The cost will depend on two main factors: communication cost and virtual testing model establishment cost. Effective communication between physical testing and the CAE team is a key success factor for this structure of parallel physical and virtual testing.

The cost for introducing the virtual testing block can be calculated as follows. Initially a fixed cost  $C$  is required to build the virtual model. This cost will depend on the company's capability in CAE modelling and simulation. With a well-established CAE department then this cost might be lower than outsourcing. As discussed before, initially, virtual (simulated) and physical testing results may differ in several ways. Discrepancies may determine the number of meetings required, and increase with the level of uncertainty and potential dependencies [16].

We are assuming that the cost for each meeting is  $X_i$ , for meetings  $i = 1, 2, \dots, n$  (as shown in Figure 12). After the model is validated, the frequency of meetings is reduced. Each meeting results in modifications and further simulation in the virtual model, at cost  $Y_i$ . A regular maintenance and opportunity cost  $M$  is incurred per unit time, for the virtual test duration  $T_v$ . If a company has committed human resources for CAE analysis throughout the process, this maintenance might not add extra marginal costs. Thus the cost of additional virtual testing model is:

$$C_{vt} = C + \sum (X_i + Y_i) + MT_v \tag{2}$$

It is assumed that this virtual testing will make the physical tests shorter without any quality loss, and given that the virtual test is representative of the physical testing.

Initially this approach of parallel physical and virtual testing will increase the cost of testing in a single gateway stage. However, the real benefit of using parallel virtual testing continues during iterations, as this might avoid extending testing into a subsequent gateway. Even with another iteration (of DV for example), the cost of running the virtual testing phase will be approximately  $\sum (X_i + Y_i) + MT_v$ , because the model building cost  $C$  will be small as the virtual testing model is already mature, the number of meetings will also be relatively low. The duration of physical testing in this phase will be shorter, and uncertainty will be decreased in redesign. Therefore, in terms of cost and time, overall savings will be improved by the proposed process.

### PROPOSED PROCESS STRUCTURE

We suggest the structural changes of the company's product development process by introducing virtual testing in parallel to the physical testing in each PDP phase. The proposed model separates virtual testing from the initial CAE analysis.

#### CAE for procurement

Using initial CAE modelling and analysis, design team can iterate the design process to develop a product that better meets cost, performance, and other constraints. CAE analyses enable the company to carry out optimization earlier in the product development cycle (front loaded), to improve product specification to the supplier. Clear, precise and accurate specification can reduce the procurement time (as mentioned by an engineer). It is often difficult to separate the design tasks and CAE tasks, because design and CAE analysis almost happens in together. Therefore the proposed model incorporates design and CAE analysis and suggests more iteration through CAE analysis before procurement of prototypes (as shown in Figure 11). Further CAE analysis will also help to set-up physical test conditions, input parameters and sensors locations for physical testing.

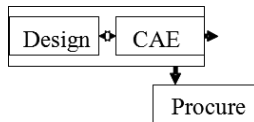

Figure 11 DESIGN AND CAE BEFORE PROCUREMENT

#### Parallel virtual testing to assist lengthy physical testing

Proposed PDP structure carefully place the virtual testing parallel to the physical testing. There are two aims: 1) to improve the understanding of intermediary physical testing results which will enable to start subsequent redesign tasks with less uncertainties, 2) reduce the physical testing duration or number of iteration in physical tests. The process of integrating

virtual and physical testing has been discussed in earlier sections and shown in Figure 12.

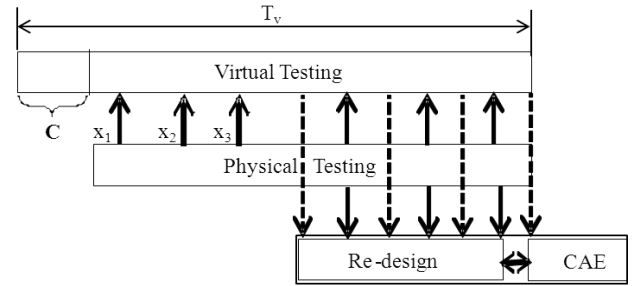

Figure 12 INFORMATION EXCHANGE BETWEEN VIRTUAL TESTING, PHYSICAL TESTING AND DESIGN

Figure 13 represents the proposed PDP model, can be achieved by incorporating Figure 11 and Figure 12. We validated the proposed model with the senior engineer in the company. It was highlighted that this combined approach of physical and virtual testing methods had the potential to reduce iterations and thereby the number of physical prototypes saving time and cost.

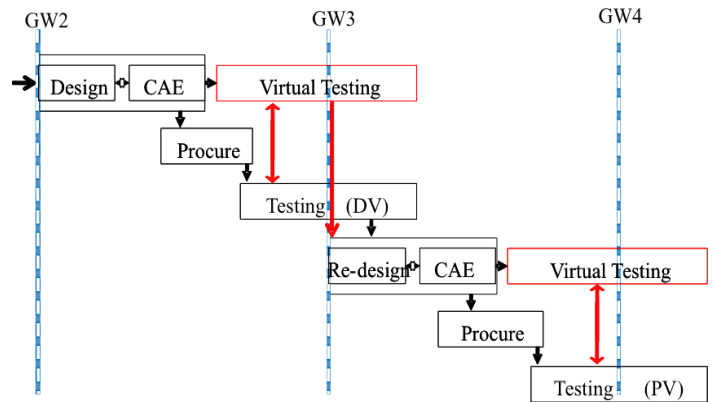

Figure 13 THE PROPOSED PDP STRUCTURE WITH ADDITIONAL VIRTUAL TESTING ACTIVITIES

### DISCUSSIONS AND CONCLUSIONS

The question remains as to whether such virtual testing modifications to PDP can be constructed in practice. The case study company has partially done this, both to assist the physical testing and to apply when physical components are not ready. The performance, reliability and durability predictions of engine components using CAE is developing rapidly. For example, the material and structural analysis group's understanding of the principles of fatigue behaviour in complex materials, combined with historical data from high temperature applications, modelled in commercial (and internal) software, with a comprehensive materials database means that the durability of engine components can be reliably predicted and probability distributions applied to perform failure rate calculations. Whilst the company recognises there are still

many technical challenges to overcome, ongoing investigative work in virtual testing currently includes gas flows and combustion chemistry, cavitations in bearing oil films and metal fatigue under extreme temperatures.

Different tests benefit from integrating virtual testing with physical testing in different ways. Some benefit by focusing the tests, or identifying future values to minimize the number of iterations, while others require running for shorter periods of time. For example, in a constant speed and load situation, an engine has its quantities of fuel and air intake regulated, with the goal of achieving desired power ratings. An engine might require several iterations in design and test to achieve these desired power ratings. A virtual testing using a validated model can predict the likely consequences of certain values of fuel and air intake of the engine, thus suggesting appropriate values for next iteration.

However, not all physical tests will benefit from this approach. For example, in a case of physical testing, where information evolves quickly and engineers can start downstream design tasks quite accurately with acceptable sensitivity, then this test doesn't require supporting parallel virtual testing. Also there will cases where some of the phenomenon of physical testing are not possible to virtually model and test, therefore this method is not applicable.

This research suggests a model to reduce the uncertainties associated with overlapping between testing and redesign. This paper has considered the scenario where the information evolution of upstream testing is slow and the sensitivity on downstream design is high a case which the literature suggests do not provide favourable conditions for overlapping. However, companies often have no other choice but to practice overlapping. The proposed model also suggests a possible strategy for overlapping providing several benefits: (1) reduced uncertainty in design and procurement, (2) focused physical testing, (3) reduced duration of physical tests (4) reduced iteration and overall cost saving.

Further work will extend validation of this model in an industrial context, including the original case study company. In particular, overlapping considerations for the design and testing of products at different scale, complexity and maturity will be compared. The model will be extended to consider multiple layered overlapping.

## REFERENCES

- [1] Thomke, S., and Bell, D. E., 2001, "Sequential Testing in Product Development," *Management Science*, pp. 308-323.
- [2] Qian, Y., Xie, M., Goh, T. N., 2010, "Optimal Testing Strategies in Overlapped Design Process," *European Journal of Operational Research*, 206(1) pp. 131-143.
- [3] Thomke, S.H., 2003, "Experimentation matters: unlocking the potential of new technologies for innovation," Harvard Business Press.
- [4] Krishnan, V., Eppinger, S. D., and Whitney, D. E., 1997, "A Model-Based Framework to Overlap Product Development Activities," *Management Science*, pp. 437-451.
- [5] Weigel, A. L., and Warmkessel, J. M., 2000, "Cross-industry characterization of spacecraft integration and test discrepancies- Transforming discrepancies into product development improvements," AIAA Space 2000 Conference and Exposition, Long Beach, CA, Anonymous.
- [6] Bertolino, A., 2009, "Software Testing Research: Achievements, Challenges, Dreams," *IEEE Transactions on Software Engineering*, 35(4).
- [7] Loch, C. H., Terwiesch, C., and Thomke, S., 2001, "Parallel and Sequential Testing of Design Alternatives," *Management Science*, pp. 663-678.
- [8] Van der Auweraer, H., and Leuridan, J., 2005, "A New Testing Paradigm for Today's Product Development Process-Part 1," *Sound and Vibration*, 39(9) pp. 14.
- [9] Hoppe, M., Engel, A., and Shachar, S., 2007, "SysTest: Improving the Verification, Validation, and Testing process—Assessing Six Industrial Pilot Projects," *Systems Engineering*, 10(4) pp. 323-347.
- [10] Lévárdy, V., Hoppe, M., and Browning, T. R., 2004, "Adaptive Test Process: An Integrated Modeling Approach for Test and Design Activities in the Product Development Process," Anonymous ASME.
- [11] Clark, K.B., and Fujimoto, T., 1991, "Product development performance: Strategy, organization, and management in the world auto industry," Harvard Business Press.
- [12] Ha, A. Y., and Porteus, E. L., 1995, "Optimal Timing of Reviews in Concurrent Design for Manufacturability," *Management Science*, pp. 1431-1447.
- [13] Smith, P. G., and Reinertsen, D. G., 1992, "Shortening the Product Development Cycle," *Research Technology Management*, 35(3) pp. 44-49.
- [14] Lin, J., Chai, K. H., Wong, Y. S., 2008, "A Dynamic Model for Managing Overlapped Iterative Product Development," *European Journal of Operational Research*, 185(1) pp. 378-392.
- [15] Terwiesch, C., and Loch, C. H., 1999, "Measuring the Effectiveness of Overlapping Development Activities," *Management Science*, pp. 455-465.
- [16] Wyatt, D. F., Eckert, C. M., and Clarkson, P. J., 2009, "Design of Product Architectures in Incrementally Developed Complex Products," *Proceedings of the 17th International Conference on Engineering Design (ICED'09)*, Vol. 4, Anonymous pp. 167-178.