



# Open Research Online

---

The Open University's repository of research publications and other research outputs

## A learning design to support the emotion regulation of investors

Conference or Workshop Item

How to cite:

Fenton-O'Creevy, Mark; Conole, Grainne; Lins, Jeffrey; Peffer, Gilbert; Adam, Marc; Lindley, Craig; Smidt, Ale; Clough, Gill and Scanlon, Eileen (2012). A learning design to support the emotion regulation of investors. In: OECD-SEBI International Conference on Investor Education, 3-4 Feb 2012, Goa, India.

For guidance on citations see [FAQs](#).

© 2012 Mark Fenton-O'Creevy

Version: Version of Record

---

Copyright and Moral Rights for the articles on this site are retained by the individual authors and/or other copyright owners. For more information on Open Research Online's data [policy](#) on reuse of materials please consult the policies page.

---

[oro.open.ac.uk](http://oro.open.ac.uk)

# A learning design to support the emotion regulation of investors

Mark Fenton-O’Creevy <sup>a</sup>, Gráinne Conole <sup>a</sup>, Jeffrey Todd Lins <sup>b</sup>, Gilbert Peffer <sup>c</sup>, Marc Adam <sup>d</sup>,  
Craig Lindley <sup>e</sup>, Ale Smidt <sup>f</sup>, Gill Clough <sup>a</sup>, Eileen Scanlon <sup>a</sup>

- a. Open University, Walton Hall, Milton Keynes, MK7 6AA, UK;
- b. Saxo Bank, Copenhagen, Denmark;
- c. CIMNE, Barcelona, Spain;
- d. University of Karlsruhe, Karlsruhe, Germany;
- e. Blekinge Tekniska Högskola, Karlskrona, Sweden;
- f. Erasmus University, Rotterdam, Netherlands;

Paper presented by invitation at OECD-SEBI International Conference on Investor Education, 3-4  
February 2012, Goa, India

[http://www.oecd.org/document/3/0,3746,en\\_2649\\_15251491\\_49028867\\_1\\_1\\_1\\_1.00.html](http://www.oecd.org/document/3/0,3746,en_2649_15251491_49028867_1_1_1_1.00.html)

**Abstract:** We describe an approach to reducing systematic bias in financial decision-making. We explicitly reject an approach based on the transmission of propositional knowledge. Rather we develop a learning design which is founded in recent research on the role of emotions and their regulation in financial decision-making. We describe a pedagogic approach which supports the development of emotion-regulation skills in a serious game environment and supports their translation into ‘real-world’ trading.

# A learning design to support the emotion regulation of investors

## 1 The Challenge of Reducing Investor Decision Bias

The xDelia project<sup>1</sup> is concerned with developing approaches to improving financial decision-making. The primary target group is investors who trade their portfolio regularly. Thus we are concerned with adult learners who have typically engaged in a significant amount of self-directed learning to support their trading practice and who tend to be highly motivated to engage in learning which may improve their investment performance. A particular concern is to develop learning approaches which improve participants’ capacity to avoid common decision traps and biases. In doing, so we need to overcome the problems which have plagued previous approaches to ‘de-biasing’.

## 2 The problems of previous ‘de-biasing’ approaches

Many forms of de-biasing training have been, at worst, counter-productive and at best had very limited impact even in lab settings [1-3]. Similarly, decision-support systems which seek to aid decision-makers in avoiding biases have been largely unproductive. Yates et al.[4] identify a series of barriers to success for such systems. The primary problem they identify, however, is the belief of users that decision aids often make decision processes unnatural and difficult, and fit poorly with naturalistic approaches to decision-making. In consequence such decision-technologies have very poor rates of take-up. As Klein [5] notes, decision-support systems typically ignore the role of expertise in complex domains and while they may (if adopted) improve the performance of novices, they risk preventing the development of expertise and over-constraining the development and appropriate application of expert intuition. A key problem with de-biasing training approaches has been the focus on shifting cognition from System 1 (fast intuitive pattern recognition mediated by the emotion system) to System 2 (conscious, reflective analysis). As Baumeister and colleagues have shown [6, 7] human capacity for self-monitoring and effortful System 2 cognition is limited and is rapidly depleted. Attempts to reduce biases by learning about biases and engaging in self-monitoring, rapidly come up against human cognitive limits.

Some critiques[8, 9] of the judgment and decision making literature emphasis that many cognitive biases identified in laboratory studies either disappear in naturalistic settings or turn out to be adaptive. However, certain biases turn out to be remarkably robust, being consistently demonstrable in both laboratory and field settings with demonstrably maladaptive effects on decision-outcomes. A wide range of decision-biases can be shown to be underpinned by emotion processes [10]. Further there is evidence that while expert professionals remain

---

<sup>1</sup> <http://www.xdelia.org> funded by the European Commission under the 7th Framework

susceptible to many decision biases, experts are often less prone to the effects of such biases when making decisions in their domain of expertise. For example, Fenton-O’Creedy et al. [11, 12] show expert traders to be less susceptible to illusions of control and current work in xDelia shows significantly lower levels of the disposition effect among experienced professional traders than among private investors. There is also evidence both from prior work [13] and xDelia studies [14] conducted on traders and investors, that the disposition effect is lower for more expert traders.

De-biasing approaches which rely primarily on shifting cognition from System 1 to System 2 are unlikely to succeed. Further, particularly but not only, in fast-paced decision environments decision-making is dominated by system 1. Thus the challenge for xDelia is to develop learning approaches which do not simply depend on increasing self-monitoring behaviours, which integrate well with practitioners’ informal learning, and support the process of developing expertise.

### 3 The target group

Unlike traders, who work professionally as decision-makers concerning the risk of a financial institution, in such functions as market making or proprietary risk taking, investors are involved in decision-making concerning risks directly related to their own wealth and ownership of assets<sup>2</sup>. While many investors trade their assets infrequently, with long time horizons, an economically important and growing subset of investors trade frequently, using online trading platforms provided by firms such as Saxo Bank (a partner in the xDelia programme) which facilitate investors participation in financial markets. Such clients may be categorized as investors, with a limited set of tools and unprivileged information flows concerning the market. These individuals are largely self-driven, transacting on a trading platform, and although it is expected that these individuals are quite qualified through their familiarity with financial markets, the nature of trading, and the risks involved in participation in investment and speculation, they typically have no institutional experience or formal training in this field. We know from xDelia exploratory studies, that investors using trading platforms are often highly motivated to acquire knowledge and skills which may give them an advantage relative to other market participants. Learning materials already provided by organisations like Saxo Bank are well used as is the opportunity to use the Saxo Bank trading platform in simulation mode. Interviews with investors<sup>3</sup> suggest the following common modes of learning: self-teaching, learning in a social setting, learning from experience and seminars/workshops.

Broking organisations have an interest in the provision of learning resources and in providing support to clients who wish to improve their trading competence. However, such support and resources have to be cost effective and scalable across many thousands of clients. Thus a challenge for xDelia is to construct learning approaches which are scalable for large groups of

---

<sup>2</sup> We should not overstate this difference since bonus structures mean that professional traders also typically have a significant financial stake in their trading performance.

<sup>3</sup> See project reports on exploratory studies and stakeholders available at [www.xdelia.org](http://www.xdelia.org)

investors trading online and which integrate well with investors existing self-guided approaches to learning.

#### **4 Developing an alternative approach**

As we note above, prior approaches to de-biasing training have been especially ineffective in transferring learning into real-world settings. The xDelia approach to learning to avoid systematic biases in financial decision-making does not rest primarily on shifting cognition from System 1 to System 2. Rather we recognise first, the importance of enhancing domain-specific task feedback and, second, the role of emotions in mediating system 1 decision-making. In particular a wide range of decision-biases can be shown to be underpinned by emotion processes [10], and a central proposition of the xDelia project is that such biases can be reduced through more effective regulation of emotions. We have a particular focus on biases in financial decision-making which have the following characteristics: i) the bias has been demonstrated to be significant in naturalistic settings as well as in the laboratory, ii) there is reason to believe that emotions play an important role in the operation of the bias and iii) The bias is tractable to detection at the level of the individual, for example, though the analysis of past trading decisions.

To develop and establish a 'proof of concept' for this approach, we have chosen to focus initially on one particular bias which fits the above criteria: the disposition effect. The disposition effect is the tendency to hold assets which would sell at a loss for longer than assets which would sell at a gain. In colloquial terms an investor who suffers from the disposition effect cuts their wins and runs their losses. This bias arises out of the desire to avoid the emotional pain of realising a loss. So long as the investor does not convert a paper loss into a realised loss they can console themselves that 'it will probably increase in value again'. The disposition effect can be reliably demonstrated in laboratory experiments but there is also a very significant body of research which shows the disposition effect to be remarkably robust and to characterise trading patterns across a wide range of financial decision-making contexts and at different decision-making time horizons [15]. The disposition effect is widely understood to be mediated by emotion processes. [16 1985, 17]. Given a sufficiently large trading record, it is possible to analyse the trading record of an individual investor to characterise their propensity to a disposition effect. A significant contribution of the xDelia project is the development of an innovative approach to measuring the disposition effect of individual investors both through analysis of trading data and in gameplay [14].

#### **5 Emotion regulation.**

The recent literature on emotion regulation makes it clear that humans do not just experience emotions; we actively regulate them [18, 19]. Recently empirical research has begun to address the role that emotion regulation processes play in individual susceptibility to biases. For example, a large scale field study of investment bank traders showed important differences between novice and expert traders in emotion regulation strategies and showed many traders and their managers to be much concerned with the regulation of emotion to avoid the biasing effect of strong emotions on trading decisions [20, 21],

Self-report measures of emotion regulation have been successfully linked in research to important outcomes. However, they depend on subjects' awareness of their habitual strategies (which may be pre-conscious) and on subjects' motivation to be honest in their self-report. Thus physiological measures are a highly desirable adjunct to such measures since they do not depend on accuracy of subjects self-assessment and may encompass pre-conscious as well as conscious emotional states. One important physiological measure which has recently been linked to emotion regulation is heart rate variability (HRV). Effective emotion regulation requires the ability to adjust physiological arousal on a moment-by-moment basis [19]. Heart-rate variability provides a measure of the moment-by-moment interaction of the sympathetic and parasympathetic nervous systems yielding information about regulated emotion responding. HRV can be considered a proxy for the central autonomic network's regulation of the timing and magnitude of an emotional response via inhibition, in response to context [22-26]. Higher levels of high frequency HRV have been associated with constructive coping in university students, lower susceptibility to framing effects, lower loss aversion and better performance in high pressure tasks; and lower high frequency HRV with the use of repressive coping strategies, anxiety, depression and rigid attentional processing of threat [22, 27-29].

## **6 A learning design to reduce investor susceptibility to bias.**

In designing a learning approach to reduce investor susceptibility to bias we have framed learning objectives at four levels: -

Level 1: Propositional Knowledge. Understand the disposition effect and emotion regulation strategies and how they relate to investor trading

Level 2: Self-awareness. Improved awareness of own profile in relation to disposition effect, habitual emotion regulation strategies; and propensity to defensive emotion regulation

Level 3: Skill development. Develop skills in recognising and avoiding the disposition effect and in effective emotion regulation in a learning environment

Level 4: Transfer. Supported transfer of skills from the learning environment into the practice context

To achieve these outcomes we need to engage participants in the acquisition of propositional knowledge, provide opportunities for feedback, develop a learning environment for skill acquisition and practice, and develop a supported approach to transfer of skills into participants real-world practice of trading. We propose a learning approach which has multiple elements: didactic elements, diagnosis and feedback on behavioural biases (both game-based and based on real world trading), learning and practicing emotion regulation strategies in a game environment, practicing emotion regulation strategies in the practice context, and support for reflective practice.

We are clear that didactic, knowledge-focused learning approaches to de-biasing have largely failed in the past [1, 3]. However, that does not mean that we entirely reject the utility of didactic approaches. First, some element of knowledge transmission is necessary to support the other approaches we espouse. For example feedback on susceptibility to a disposition effect or training in improving emotion regulation is unlikely to be effective without an understanding of

the nature of the disposition effect and the meaning of emotion regulation. Second, the impact of didactic approaches on real world practice should be significantly enhanced to the extent that the learning is brought alongside and placed in the context of the specific domain of practice (in this case investors trading on a trading platform).

### **Diagnosis and feedback.**

Feedback is an important component of any learning process. Yet, there is considerable evidence that many feedback interventions are ineffective. For example a major review and meta-analysis of over 3000 studies found that while, on average, feedback interventions improved performance, up to a third of feedback interventions actually reduced performance [30]. Simple feedback on outcomes is particularly problematic when tasks are complex or important antecedents of outcomes are beyond the control of the feedback recipient. This is very much the case for the trading tasks faced by investors. Poor strategies can produce good outcomes due to unpredictable changes in the market and vice-versa. In these circumstances negative outcome feedback may tend to trigger defensive processes (in order to avoid negative emotions) and positive outcome feedback may generate false beliefs about the value of particular strategies or the nature of market processes. For investors, outcome feedback (ie feedback on investment outcomes) has both low predictive value (past returns are a poor guide to future returns) and low explanatory value (it contains little of value in understanding reasons for failure or success). Indeed we can understand biases such as the disposition effect as arising out of failures in the utility of outcome feedback for investors.

In contrast to outcome feedback which concerns the accuracy or correctness of response, cognitive feedback concerns the how and why that underpins the outcomes. There is evidence that (properly designed) cognitive feedback has significantly greater utility for learning than outcome feedback in complex real world domains. Some of this evidence is specific to trading tasks. For example a study of the decision making of professional security analysts [31] found better performing security analysts to be more likely to ignore outcome feedback and more likely to focus on information about underlying issues such as fundamental market factors.

Thus we take the position that outcome feedback will be most relevant where we have been able to extract relatively simple aspects of expert performance which can be trained to some extent in isolation from other task elements. Where the focus is on more holistic tasks the focus should be on feedback with explanatory power.

At the level of the whole investment task feedback on biases and emotion regulation has explanatory power (and, research evidence is beginning to suggest, predictive power) and can be understood as an instance of cognitive feedback (especially when teamed with structured opportunities for reflection).

### **Feedback on biases.**

Where investors have an existing accessible track record of trading, it is possible to analyse past behaviour to diagnose the extent to which they display key biases such as the disposition effect. Feedback can then be provided at intervals on the extent of bias apparent in trading behaviours. However, where investors are only just beginning to trade or where prior trading records are

not easily accessible, other mechanisms for feedback on propensity to biases are required. Further, if investors are to practice new approaches to regulating their trading behaviours it is important that they can do so in an environment where they do not put their investments at risk. Both the need for feedback in the absence of a trading record and the value of a safe 'play-space', point to the value of trading games in which simple but ecologically valid trading tasks can be engaged in and biases can be detected and diagnosed.

We make use of both approaches in our learning interventions. We have designed (and continue to elaborate) algorithms and data management approaches to detect the disposition effect on the basis of investors trading history and have designed (and continue to develop) a game (the Two Index Game) which provides a simple trading game in which the disposition effect can be elicited and diagnosed. Work to date shows the game to reliably elicit a disposition effect with significant variability between individuals in the level of disposition effect. It remains an empirical question as to whether bias in the game will correlate with bias in actual trading. This will be an important element of game evaluation. If there is such a correlation the game can play a useful diagnostic role, if not it will still have utility in improving investor understanding of the nature of the disposition effect.

### **Feedback on emotion regulation.**

A key element of our approach is to support improvements in financial decision-making by supporting the enhancement of emotion regulation skills.

Specifically we use physiological feedback on arousal during games to make performance depend on managing physiological arousal. Since management of physiological arousal and awareness of physiological state is closely related to effective emotion regulation this should support development of emotion regulation skill (to date we have developed two games, a first person shooter and an auction game to fulfil this function). These games support development of emotion regulation skills in three ways. First, they provide an environment in which management of arousal levels can be practiced and rewarded. Second, by directing attention to the participant's own physiological state they encourage improved interoception (awareness of internal physiological state); there is empirical evidence for a link between interoception and perception and regulation of emotion state [32, 33]. Third, they provide a context for the practice and consolidation of emotion regulation approaches developed in other contexts (for example mindfulness approaches).

While there is existing evidence for the efficacy of physiological approaches to learning to manage emotional arousal there is also value, in this context, in cognitive feedback, which provides engagement with the processes entailed in effective emotion regulation.

We are also investigating the efficacy of mindfulness approaches [34-36] in improving emotion regulation. There is significant evidence of success in using mindfulness training as a foundation for more effective regulation of emotions and behaviour [34, 35]. We are developing approaches to online delivery of mindfulness training that can be delivered via a learning space attached to a trading platform and conducting a series of trials of the effects of mindfulness inductions on mood and emotion regulation and on task performance in relation to financial decision-making games. Such inductions can be delivered via a web-based learning platform.



In summary we have a strong emphasis on cognitive feedback in relation to managing bias in decision processes and managing emotion regulation as key aspects of effective trading performance. Feedback will play an important role in learning both in relation to learning games and in relation to real world investment practice.

### **Critical reflection.**

Learners will receive feedback in both the game setting and practice setting. They have opportunities for learning in both spheres. The challenge is to support translation of learning from the game domain to the practice domain. The key is to support and enable critical reflection on practice drawing on the insights from game based learning. Such reflection can be informed by structured approaches to writing down and reviewing trading strategies, accompanied by structured reflection about emotional state and management of emotion while making key decisions.

This translation process will be aided by template and diary based reflection tools. This will include simple tools for recording and reflecting on emotion state (c.f. [38]). For example, such approaches may highlight when behaviour is inconsistent with planned trading strategy at a period of significant anxiety and provide the opportunity to review how this came about.

## **7 Developing an Integrated Approach to Reducing Investor Susceptibility to the Disposition Effect**

For knowledge-intensive work and practice, learning does involve the acquisition of propositional knowledge. However development of expertise also requires the development of complex repertoires of behaviour with strong elements of automaticity. The challenge for this project is to design learning interventions which support the normal processes of expertise development rather than substitute for them. This implies that any formal learning approaches should not be a substitute for informal practice-based learning, but rather should help support and scaffold the informal learning that is part of everyday practice.

However, while practice-based experiential learning is of core importance to the development of expertise, it also has important limitations. First, the kind of playful approach that can support learning through experimentation is fraught with risks in a practice setting. Second, what is learned may often be quite maladaptive. Humans often over-learn from single episodes; for example a prior study [21] found trader managers to be much concerned with avoiding bad learning outcomes when novice traders experience large losses or large gains early in their careers. Serious games can then potentially provide a safer and more playful environment for learning. Such games can be brought together with informal practice-based learning in a cycle of critical reflection.

A core problem for the use of games for learning is that of transfer. How do we ensure that learning in a game environment transfers beyond the bounds of the game? The first strategy involves attention to ecological validity. Do elements of game performance sufficiently mimic key elements of work performance to make transfer realistic? The second strategy concerns a learning framework which brings game based learning alongside feedback on performance in

the practice setting (trading or investing). Skills are first developed and practiced in a game setting before being practiced (with support and feedback) in the trading or investment setting.

## **8 The learning intervention we are developing**

We outline below a description of an investor learning pathway using the resources developed in xDelia and being implemented and tested for the Saxo Bank client environment, which is aimed at achieving these learning objectives. In practice we expect the learning pathway to vary between participants since participants needs will vary and the learning will be largely self-directed. There will be guidance and structure available which include advice on learning pathway, rate of study, and study time, but participants will not be constrained to follow a specific path through the learning elements nor to engage with them all.

### **Learning pathway.**

We first provide a narrative account of an 'ideal' learning pathway for a participant before rehearsing a series of learning design views to further clarify our approach.

- 1) The pathway starts with an opportunity to gain diagnostic information on propensity to disposition effect and own approach to emotion regulation. The aim here is to, first, develop the participant's self-awareness in relation to the disposition effect and emotion regulation approaches. Second, the diagnosis process provides a vehicle for delivery of propositional knowledge in relation to the disposition effect, the role of emotion in trading biases and emotion regulation strategies and how they relate to investor trading. This should increase participant engagement with the concepts by making them highly personally salient. Diagnosis is achieved through: -
  - a) Questionnaire measures on emotion regulation strategies
  - b) (For investors with existing trading history) diagnosis of level of disposition effect shown in past trading behaviour
  - c) (Especially for investors without available trading history) playing the 'Two Index' trading game to diagnose propensity to disposition effect. This game uses a simple trading task under time pressure to induce a disposition effect in players. Players vary in their susceptibility to the bias.
  - d) Optionally for investors using a day trading centre there will an opportunity to get feedback on heart rate variability and heart rate across a day of trading. The heart rate data will be logged and presented alongside trading logs with guidance on making sense of the data in relation to trading activity. Results to date are promising in the relationship between such cardio data and performance and in the value of the cardio-data in identifying periods of significant stress related to trading conditions.
- 2) Alongside feedback, the investor is given access to multi-media didactic materials on disposition effect and emotion regulation and the likely meaning of the feedback in relation to their own investment practices.
- 3) In the next stage the Two Index Game becomes a learning space where the participant can try out and get feedback on different strategies for avoiding the disposition effect. In a first iteration they can play the game multiple times and experiment with monitoring and modifying their own behaviour.

- 4) In this stage participants get the opportunity to engage with learning elements which support the development of enhanced emotion regulation. Two approaches are involved here: a) mindfulness inductions; b) a first person shooting game in which effective management of physiological arousal is rewarded by increased accuracy of weapon sights.. The latter approach will involve participants accessing a game kit which includes physiological sensor technology. This would most likely be made available through day trading centres. This is followed by further opportunities to play games which involve trading tasks (Two Index Game and Auction Game) but this time accompanied by physiological feedback on arousal and regulated responding (heart rate and heart rate variability).
- 5) An online diary tool integrated with the trading platform supports a structured approach to writing down and reviewing real world trading strategies including reviewing emotion state and emotion regulation. Optionally, for those based in day trading centres, feedback on arousal and self-regulation based on physiological sensors can be integrated into the diary tool alongside time stamped trading logs.
- 6) The diary tool is linked to template-based structured reflection tasks. Output from these tasks is stored in the diary tool. This provides opportunities to review progress in a structured way, including additional feedback opportunities on disposition effect and emotion regulation.
- 7) Alongside such learning opportunities participants should have access to peer discussions in on line forums with tools to support development of peer learning groups interested in discussion of their regulation of emotions and management of disposition effect.

## **9 Learning design views for the learning intervention**

This section provides an overview of an X-Delia learning intervention described through a series of learning design conceptual views that provide different lenses on the different aspects of the learning intervention [41]. In terms of timescales the learning pathway is intended to extend over six months, different individuals will do different aspects and some may take forward into their work practice, therefore the following are intended as an indicative average amount of time on different aspects of the learning intervention; in reality of course different learners will spend a different amount of time working on this.

### **Learning intervention view.**

1. Guidance and support: a self-directed learning pathway (up to six months)
2. Content and activities: games, didactic material, real-world practice
3. Communication and collaboration: peer discussion in the forums
4. Reflection and demonstration: diagnostic feedback), critical reflection

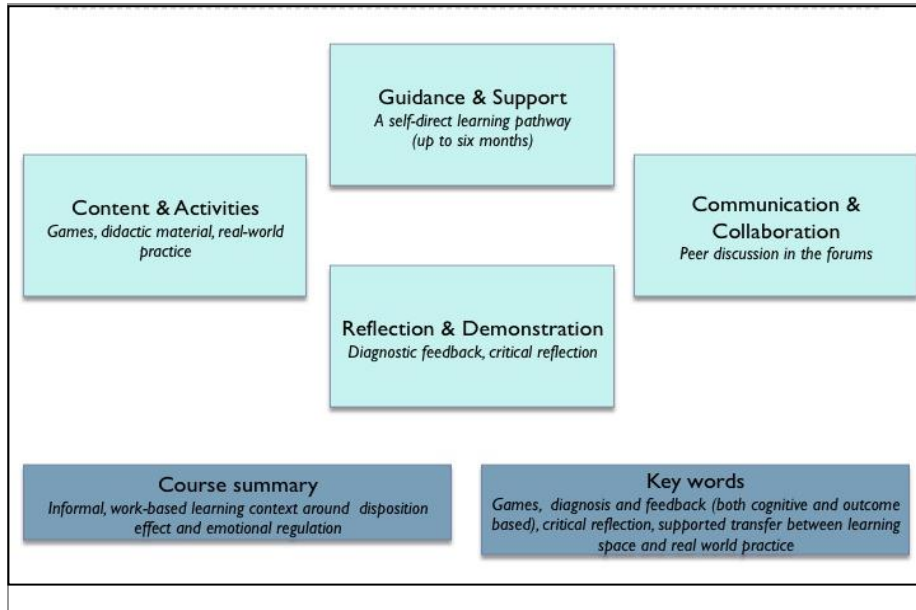

Figure 3.1 – Learning intervention map

**Pedagogical profile.**

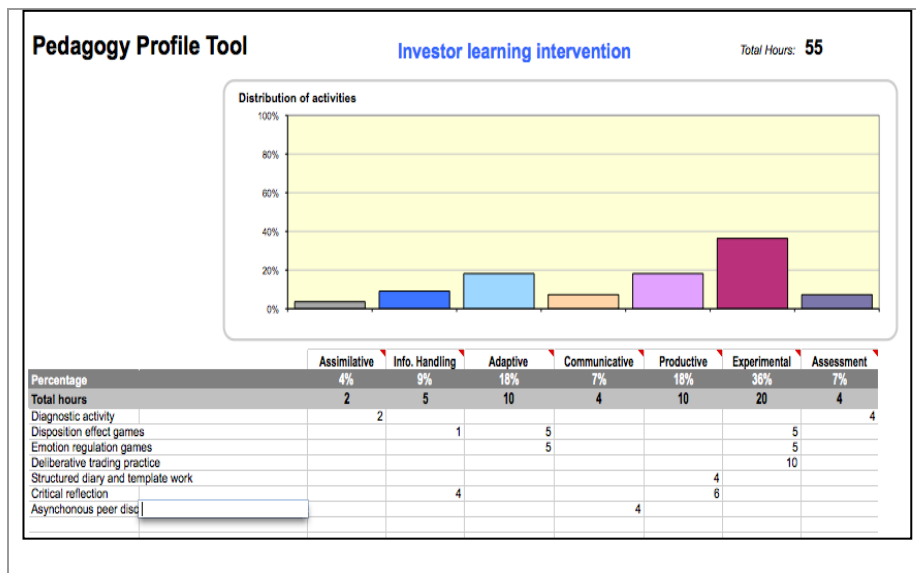

Figure 3.2 – Pedagogical profile

**Learning intervention dimensions.**

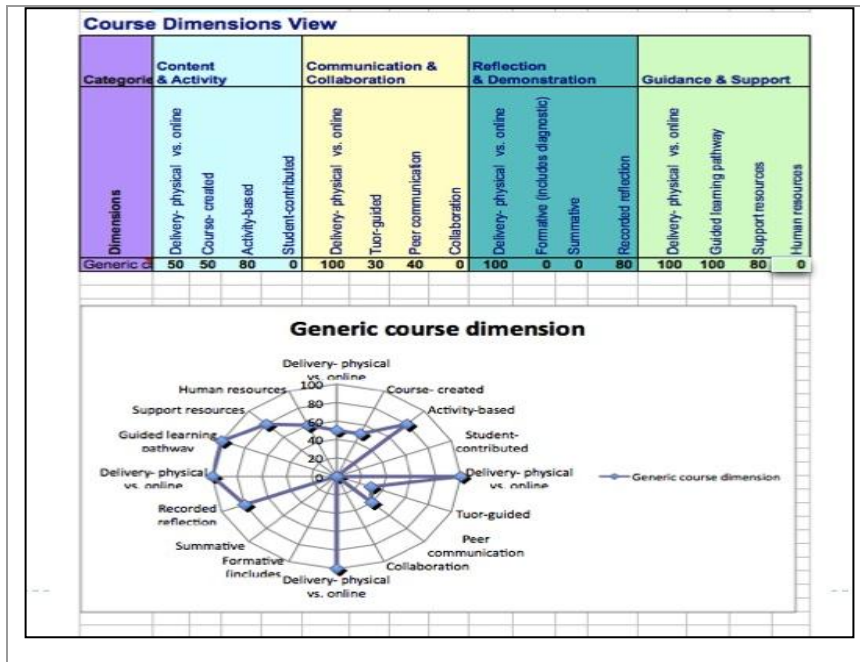

Figure 3.3 – Learning intervention dimensions

**Learning objectives.**

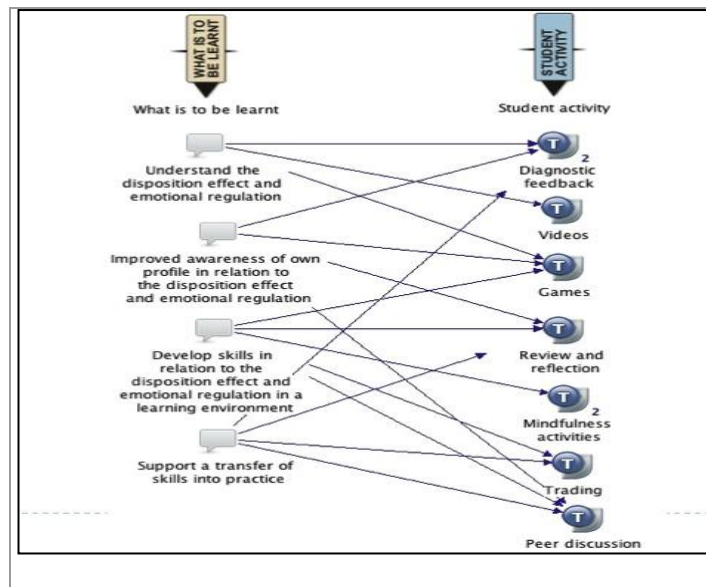

Figure 3.4 – Learning objectives

**Task swimlane: Learning activities.**

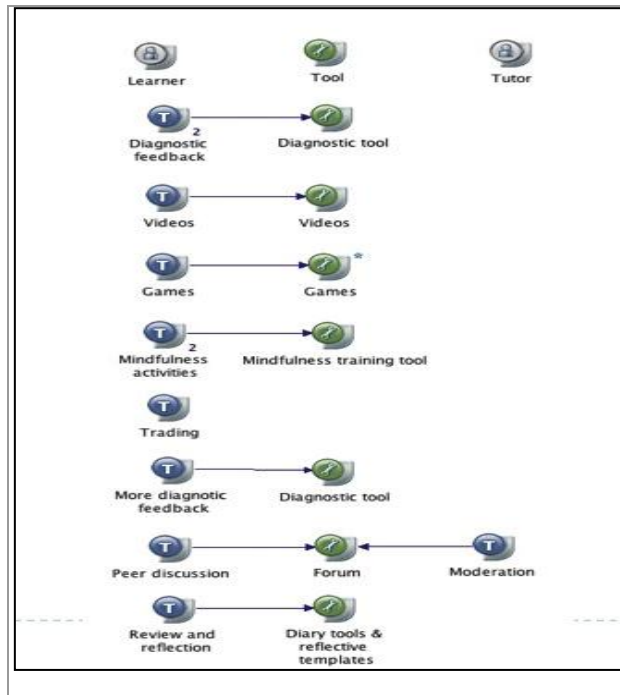

Figure 3.5 – Learning activities

## 10 Conclusion

This paper has described a learning-design based approach [42] to support emotional regulation in investors through a series of Technology-Enhanced Learning (TEL) interventions. We have drawn on the latest empirical evidence from TEL research and e-learning pedagogies [43-46] in terms of the design of the learning intervention. This has included understanding how to promote effective pedagogical approaches (such as critical reflection and feedback) through the use of technologies. The representations described help to both guide the design of the intervention and make it more explicit and shareable.

## 11 References

1. Fischhoff, B., *Debiasing*, in *Judgement under uncertainty: Heuristics and biases*, D. Kahnman, P. Slovic, and A. Tversky., Editors. 1982, Cambridge University Press: Cambridge.
2. Bazerman, M.H., *Judgment in managerial decision making*. 2002: Wiley New York.
3. Lilienfeld, S.O., R. Ammirati, and K. Landfield, *Giving Debiasing Away: Can Psychological Research on Correcting Cognitive Errors Promote Human Welfare?* *Perspectives on Psychological Science*, 2009. 4(4): p. 390.
4. Yates, J., E. Veinott, and A. Patalano, *Hard decisions, bad decisions: on decision quality and decision aiding*. *Emerging perspectives on judgment and decision research*, 2003: p. 13–63.
5. Klein, G., *Streetlights and Shadows: Searching for the Keys to Adaptive Decision-Making*. 2009, Cambridge, MA: MIT Press.
6. Baumeister, R.F., et al., *Ego depletion: is the active self a limited resource?* *Journal of Personality and Social Psychology*, 1998. 74(5): p. 1252-65.
7. Muraven, M. and R.F. Baumeister, *Self-regulation and depletion of limited resources: Does self-control resemble a muscle*. *Psychological Bulletin*, 2000. 126(2): p. 247-259.
8. Gigerenzer, G., *Adaptive Thinking: Rationality in the Real World*. 2000: Oxford University Press, USA.
9. Gigerenzer, G., *Fast and frugal heuristics: The tools of bounded rationality*. *Handbook of judgement and decision making*, Oxford (Blackwell), 2004.
10. Loewenstein, G. and J. Lerner, *The role of affect in decision making*. *Handbook of affective science*, 2003: p. 619-642.
11. Fenton-O'Creevy, M., et al., *Trading on illusions: Unrealistic perceptions of control and trading performance*. *Journal of Occupational and Organizational Psychology*, 2003. 76: p. 53-68.
12. Fenton-O'Creevy, M., et al., *Traders: Risks, decisions and management in financial markets*. 2005, Oxford: Oxford University Press.
13. Dhar, R. and N. Zhu, *Up close and personal: investor sophistication and the disposition effect*. *Management Science*, 2006. 52(5): p. 726.
14. Lins, J.T. and J.T. Yee, *Disposition effect among professional traders and private investors*. 2011, Saxo Bank.
15. Barberis, N. and W. Xiong, *What Drives the Disposition Effect? An Analysis of a Long Standing Preference Based Explanation*. *The Journal of Finance*, 2009. 64(2): p. 751-784.
16. Thaler, R.H., *Mental accounting matters*. *Journal of Behavioral Decision Making*, 1999. 12(3): p. 183-206.

17. Lee, K., R. Kraussl, and L. Paas, *The effect of anticipated and experienced regret and pride on investors' future selling decisions*. 2009.
18. Gross, J., *Emotion regulation: affective, cognitive, and social consequences*. *Psychophysiology*, 2002. **39**: p. 281.
19. Gross, J.J. and R.A. Thompson, *Emotion regulation: Conceptual foundations*, in *Handbook of emotion regulation*, J.J. Gross, Editor. 2007, Guilford Press: New York, NY.
20. Fenton-O'Creevy, M.P., et al., *Traders - Risks, Decisions, and Management in Financial Markets*. 2005, Oxford: Oxford University Press.
21. Fenton-O'Creevy, M., et al., *Thinking, feeling and deciding: The influence of emotions on the decision making and performance of traders*. *Journal of Organizational Behavior*, 2010: p. n/a-n/a.
22. Appelhans, B. and L. Luecken, *Heart rate variability as an index of regulated emotional responding*. *Review of general psychology*, 2006. **10**(3): p. 229.
23. Moses, Z., L. Luecken, and J. Eason. *Measuring Task-related Changes in Heart Rate Variability*. 2007.
24. Utsey, S. and J. Hook, *Heart rate variability as a physiological moderator of the relationship between race-related stress and psychological distress in African Americans*. *Cultural Diversity and Ethnic Minority Psychology*, 2007. **13**(3): p. 250.
25. Geisler, F. and T. Kubiak, *Heart rate variability predicts self control in goal pursuit*. *European Journal of Personality*, 2009. **23**(8): p. 623-633.
26. Hansen, A., B. Johnsen, and J. Thayer, *Relationship between heart rate variability and cognitive function during threat of shock*. *Anxiety, Stress and Coping*, 2009. **22**(1): p. 77-89.
27. Sokol-Hessner, P., et al., *Thinking like a trader selectively reduces individuals' loss aversion*. *Proceedings of the National Academy of Sciences*, 2009. **106**(13): p. 5035.
28. Wallace, J.C., et al., *Examining the Consequences in the Tendency to Suppress and Reappraise Emotions on Task-Related Job Performance*. *Human Performance*, 2009. **22**: p. 23-43.
29. Sutterlin, S., et al. (2010) *Frames, decisions, and cardiac autonomic control*. *Social Neuroscience* **Jul 21**: 1-9
30. Kluger, A. and A. DeNisi, *Effects of feedback intervention on performance: A historical review, a meta-analysis, and a preliminary feedback intervention theory*. *Psychological Bulletin*, 1996. **119**(2): p. 254.
31. Jacoby, J., et al., *When feedback is ignored: Disutility of outcome feedback*. *Journal of Applied Psychology*, 1984. **69**(3): p. 531-545.
32. Damasio, A.R., *The feeling of what happens: Body and emotion in the making of consciousness*. 2000: Mariner Books.



- 16 Mark Fenton-O'Creevy, Grainne Conole\*, Jeffrey Todd Lins, Gilbert Pepper, Marc Adam, Craig Lindley
33. Wiens, S., *Interoception in emotional experience*. *Current Opinion in Neurology*, 2005. **18**(4): p. 442-447.
34. Kabat-Zinn, J., et al., *Effectiveness of a meditation-based stress reduction program in the treatment of anxiety disorders*. *American Journal of Psychiatry*, 1992. **149**(7): p. 936.
35. Davidson, R.J., et al., *Alterations in brain and immune function produced by mindfulness meditation*. *Psychosomatic medicine*, 2003. **65**(4): p. 564.
36. Kabat-Zinn, J., *Mindfulness-based interventions in context: Past, present, and future*. *Clinical Psychology Science and Practice*, 2003. **10**(2): p. 144-156.
37. Baer, R.A., *Mindfulness training as a clinical intervention: A conceptual and empirical review*. *Clinical Psychology Science and Practice*, 2003. **10**(2): p. 125-143.
38. Oglvie, J.R. and M.L. Carsky, *Building emotional intelligence in negotiations*. *International Journal of Conflict Management*, 2002. **13**(4): p. 381-400.
39. Ericsson, K.A., *An introduction to the Cambridge Handbook of Expertise and Expert Performance, its development organization and content*, in *The Cambridge Handbook of Expertise and Expert Performance*, K.A. Ericsson, et al., Editors. 2006, Cambridge University Press.: Cambridge. p. 3-20.
40. Hakkarainen, K., *Communities of Networked Expertise: Professional and Educational Perspectives*. 2004: Elsevier Science. Conole, G., *Learning design - making practice explicit, keynote and paper*, in *ConnectEd - 2nd International conference on design education*. 2010.
41. Conole, G. *Designing for learning in an open world*, New York: Springer. Forthcoming.
42. Conole, G. and Oliver, M. (Eds), *Contemporary perspectives in e-learning research*, London: Routledge. 2007
43. Wang, F. and Hannafin, M.J., *Design-based research and Technology-Enhanced Learning environments*, *Educational Technology Research and Development*, Vol. 53, No. 4, 5-23. 2005.
44. Andrews, R. and Haythornthwaite, C., *The sage handbook of e-learning research*, London: Sage.
45. Conole, G. Review of pedagogical models and frameworks, available online <http://cloudworks.ac.uk/cloud/view/2982>