

Open Research Online

The Open University's repository of research publications and other research outputs

The use of EM-CCDs on high resolution soft x-ray spectrometers

Conference or Workshop Item

How to cite:

Tutt, James; Holland, Andrew; Murray, Neil; Harriss, Richard; Hall, David; Soman, Matthew; McEntaffer, Randall L. and Endicott, James (2011). The use of EM-CCDs on high resolution soft x-ray spectrometers. In: UV, X-Ray, and Gamma-Ray Space Instrumentation for Astronomy XVII, 21-24 Aug 2011, San Diego.

For guidance on citations see [FAQs](#).

© 2011 Society of Photo-Optical Instrumentation Engineers (SPIE)

Version: Version of Record

Link(s) to article on publisher's website:
<http://dx.doi.org/doi:10.1117/12.895981>

Copyright and Moral Rights for the articles on this site are retained by the individual authors and/or other copyright owners. For more information on Open Research Online's data [policy](#) on reuse of materials please consult the policies page.

oro.open.ac.uk

The use of EM-CCDs on high resolution soft X-ray spectrometers

James H. Tutt^a, Andrew D. Holland^a, Neil J. Murray^a, Richard D. Harriss^a, David J. Hall^a,
Matt Soman^a, Randall L. McEntaffer^b, James Endicott^c

^aThe Open University, e2v Centre for Electronic Imaging, Walton Hall, Milton Keynes, MK7
6AA, UK;

^bThe University of Iowa, Department of Physics and Astrophysics, Van Allen Hall, Iowa City,
IA, USA;

^ce2v, 106 Waterhouse Lane, Chelmsford, Essex, CM1 2QU, UK

ABSTRACT

Charge-Coupled Devices (CCDs) have been traditionally used on high resolution soft X-ray spectrometers, but with their ability to increase the signal level in the detector before the readout noise of the system is added, Electron-Multiplying CCDs (EM-CCDs) have the potential to offer many advantages in soft X-ray detection. Through this signal multiplication an EM-CCD has advantages over conventional CCDs of increased signal, suppressed noise, faster readout speeds for the same equivalent readout noise and an increased immunity to Electro-Magnetic Interference. This paper will look at present and future space applications for high resolution soft X-ray spectrometers and assess the advantages and disadvantages of using EM-CCDs in these applications.

Keywords: CCD, EM-CCD, Soft X-ray, Spectrometer, Excess Noise Factor, Modified Fano Factor

1. INTRODUCTION

High resolution soft X-ray spectrometers are used in many applications. In space they are used to determine the dynamics of the hot Universe as well as looking at the formation and evolution of black holes and galaxies through high resolution emission and absorption spectroscopy. In terrestrial applications, soft X-ray spectroscopy can be used in medical applications through techniques like RIXS (Resonant Inelastic X-ray Scattering).¹

1.1 Current X-ray spectrometers

There are already missions in space and instruments on the ground that use high resolution soft X-ray spectrometers and these can be used as a benchmark when looking at the possible improvements that the use of EM-CCDs could have in future applications. Some of these applications are outlined below.

1.1.1 XMM-Newton

XMM-Newton is part of the ESA Horizon 2000 science programme. Included in the payload is the Reflection Grating Spectrometer (RGS) which provides high resolution spectroscopy ($E/\delta E \sim 300$) in the 0.33 keV to 2.5 keV energy range.² The RGS instrument is constructed of two on-plane grating arrays that disperse half of the X-ray beam onto two separate detector arrays made up of deep depletion, back-illuminated CCDs. The spatial position at which the X-rays are incident on the CCD array determines the energy of the incident photon and the inherent energy resolution of the detectors is used to separate the different orders of X-rays.³ XMM-Newton has been in orbit for the past 12 years and has generated large amounts of high resolution spectroscopy data over the course of its lifetime.

Further author information: (Send correspondence to James H. Tutt)

James H. Tutt: E-mail: j.h.tutt@open.ac.uk, Telephone: +44 (0)1980 332 769

1.1.2 Chandra

Chandra was launched by NASA in 1999 and is the 3rd of NASA's four great observatories (Hubble Space Telescope, Compton Gamma Ray Observatory and Spitzer Space Telescope are the other three). Chandra is sensitive to X-ray sources two orders of magnitude fainter than could be previously observed due to its large effective area, making it the most sensitive X-ray telescope in space. The Chandra payload includes two transmission grating spectrometers: the Low Energy Transmission Grating (LETG) and the High Energy Transmission Grating (HETG), designed to produce high resolution spectra and images of violent, high-temperature events in order to better understand the structure and evolution of the Universe. The LETG has an energy range of 0.08 keV to 2 keV and the HETG covers the 0.4 keV to 10 keV energy range. The Chandra instruments have a resolution $E/\delta E \sim 300$ below 3 keV.⁴

1.1.3 Super Advanced X-ray Emission Spectrometer (SAXES) at the Paul Scherrer Institut (PSI)

The Paul Scherrer Institut (PSI) is a facility based just outside Zurich in Switzerland. It contains the Swiss Light Source (SLS), a high energy (2.4 GeV) synchrotron. One of the experiments at the SLS is the Super Advanced X-ray Emission Spectrometer (SAXES) that uses Resonant Inelastic X-ray Scattering (RIXS) to analyse samples.⁵ X-rays within the range of 400 eV to 1600 eV are incident on a sample and dispersed by a grating across the face of a CCD.

1.2 Future X-ray spectrometers

The current high resolution soft X-ray spectrometers based in space are coming to the end of their useful lifetime and so future missions are in the planning stages so that the current spectroscopy ability can be maintained and improved.

1.2.1 WHIMex (Warm-Hot Intergalactic Medium Explorer)

WHIMex is a bespoke explorer mission that is being considered by NASA to look for the Warm Hot Intergalactic Medium (WHIM). The concept is that an explorer scale mission will be put in orbit with an Off-Plane Grating instrument in order to provide high resolution X-ray spectroscopy ($E/\delta E > 4000$) over the 0.15 keV to 2 keV energy range. WHIM-EX will look to probe the hot, tenuous gas that populates the voids between galaxies as this is thought to be the place where most of the baryons in the Universe reside. The bulk of this gas is hot (10^6 K to 10^7 K), radiate at soft X-ray energies and it is tenuous. Therefore it has to be observed in absorption in the soft energy bandpass. The incident X-rays enter the optics with a collecting area of 360 cm^2 , where it is dispersed by nested, radial gratings in the extreme off-plane mount.⁶ WHIM-EX is a cost effective way of achieving the majority of the science aimed for with the X-ray Grating Spectrometer proposed for the International X-ray Observatory.

1.2.2 The International X-ray Observatory (IXO)

The International X-ray Observatory (IXO) is a collaboration between NASA, ESA and JAXA to provide the next generation X-ray observatory. It is proposed to contain several instruments including a high resolution X-ray spectrometer ($E/\delta E > 3000$). The phase 0 study for the IXO OPXGS considered ways to improve the resolution and energy range of the instrument. EM-CCDs were identified as the principal way to detect sub 300 eV X-rays amongst detector background and noise. This paper will look into the Off-Plane X-ray Grating Spectrometer (OP-XGS) in more detail.⁷

2. THE OFF-PLANE X-RAY GRATING SPECTROMETER (OP-XGS)

The OP-XGS is a high resolution X-ray gratings spectrometer that can be used to probe the physics of the hot Universe, including black hole formation and evolution, galaxy formation, the WHIM and feedback mechanisms in the Universe. It is able to do this due to its high resolution ($E/\delta E > 3000$), allowing absorption features to be studied, as well as the large effective area ($> 1000 \text{ cm}^2$) across the 0.3 keV to 1 keV energy range allowing the study of faint sources. Figure 1 shows the basic design of the OP-SGX instrument. The OP-XGS is made up of nested, radially grooved gratings in the extreme off-plane mount. The direction of the grooves (parallel

to the direction of incoming X-rays) cause the X-rays to be dispersed conically about the zero-order position of the gratings. In order to maximise the throughput of the instrument, the gratings are also blazed. This means that the gratings are manufactured at an angle to the horizontal, preferentially throwing the dispersed X-rays to one side of the zero order, allowing almost all of the X-rays to be collected by one CCD camera array.⁸ This is shown in Figure 2.

In order to achieve the baseline effective area across the whole of the energy range, several orders of dispersed X-rays have to be used. Figure 3 shows how this combination of different orders is used to maximise the overall efficiency of the gratings and the throughput of the instrument. However, as several orders of the dispersed X-rays have to be used, different energies of X-ray at different orders can be incident on the CCD camera array at the same spatial position. The inherent energy resolution of the CCD is therefore required to distinguish between photons incident at the same position on the CCD. Figure 4 shows the position that the dispersed X-rays fall on the CCD array in relation to the photon energy and the order of the dispersed light. At 180 mm

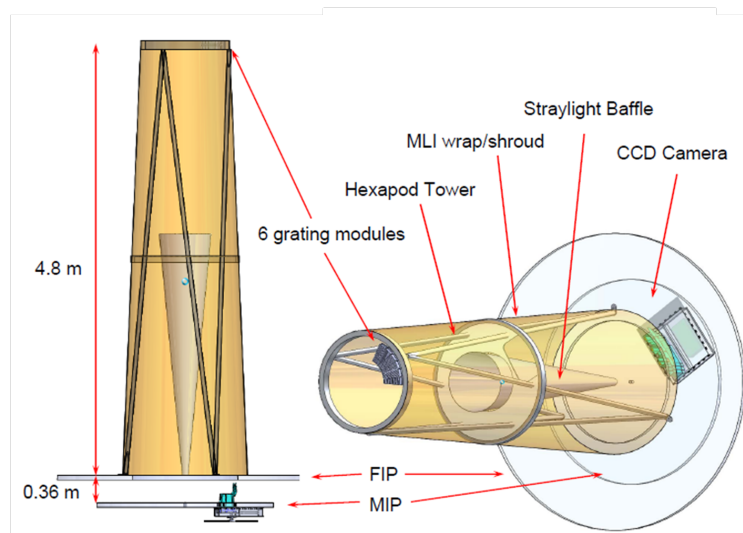

Figure 1. The tower structure for the OP-XGS has with gratings mounted at the top is shown. The CCD array is offset from the main focus of the telescope in order to collect the dispersed X-rays

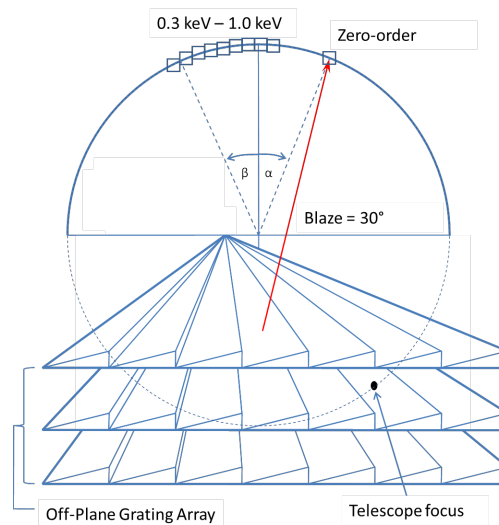

Figure 2. Incident X-rays are incident on the gratings that are at 30° blaze and then dispersed onto the CCD array at one side of the zero-order position. The gratings are shown to extend to the telescope focal plane so that they can be shown to be radially grooved⁸

from the zero order position, a 400 eV photon in the second order and a 600 eV photon in the third order will be at the same position on the CCD array. This means that the CCD will have to be able to distinguish between these two energies using the inherent energy resolution.

The CCD camera array is located at a throw of 5.16 m from the gratings and, along with the groove density of the gratings, this distance determines the dispersion of the incident X-rays. In order to create redundancy in the system, each module of gratings (six in total) disperses a separate spectrum across the CCD array. The basic layout of the array can be seen in Figure 5.

The position of the photon interaction on the CCD determines the energy of the incident photon when the order of the dispersed photon has been determined, allowing the baseline resolution to be achieved. The baseline design is to use conventional CCDs; however, a study has been performed to look at the possibility of using EM-CCDs.¹⁰

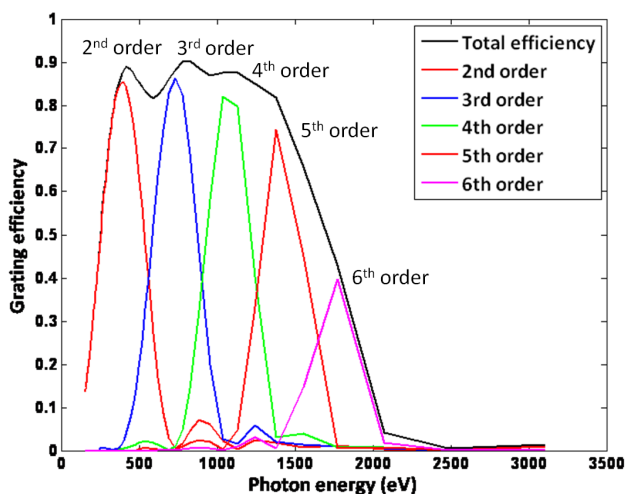

Figure 3. Total grating efficiency shown as a function of the combination of different orders of dispersed X-rays. The total grating efficiency comes from the combination of these diffraction orders

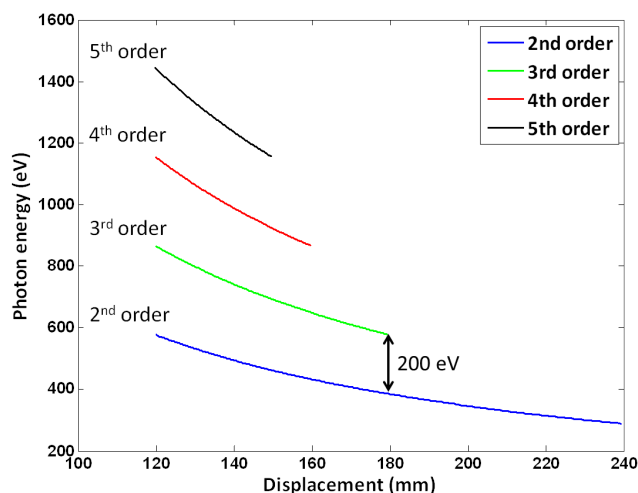

Figure 4. Photon energy at different orders in relation to the position that they are incident on the CCD camera array. This shows the overlapping of different diffraction orders at different energies overlapping at the same point on the CCDs⁹

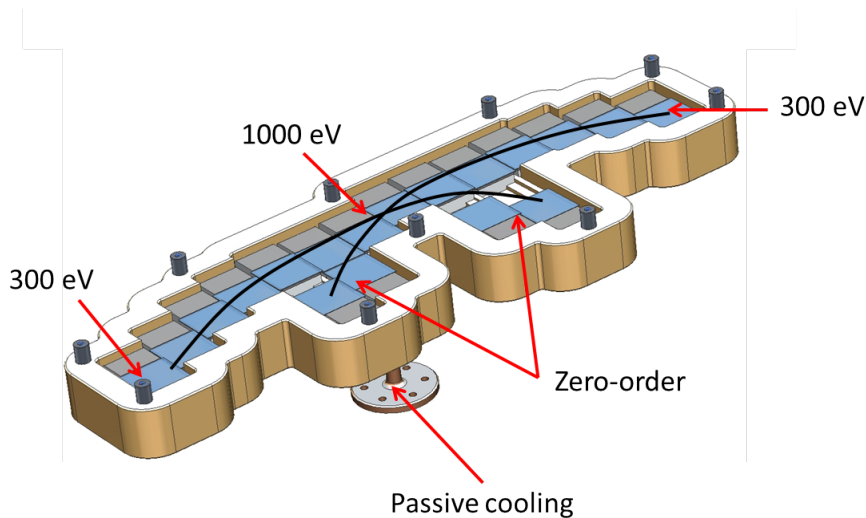

Figure 5. CAD image of the proposed CCD camera array with two projected spectra showing how the dispersed X-rays from the grating modules can be detected

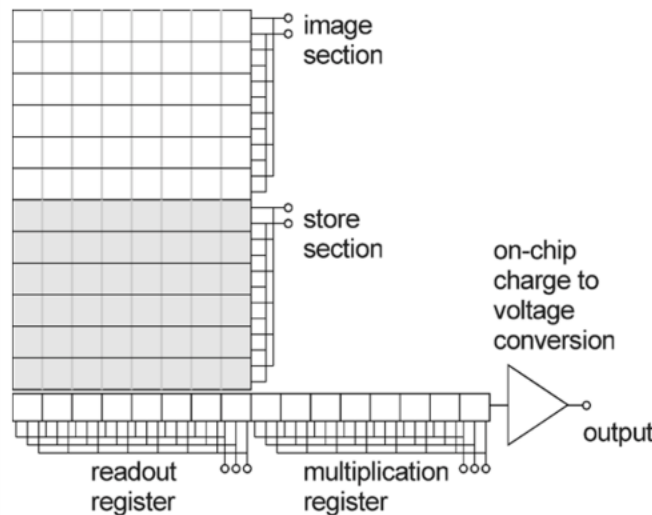

Figure 6. Schematic of an EM-CCD showing the multiplication register added after the serial register on the CCD before the output node¹²

3. ELECTRON MULTIPLYING CCD (EM-CCD)

EM-CCDs take the basic principles of conventional CCDs and add an electron multiplication register that allows amplification of the detected signal before the charge packet is read out. This amplification of the charge packet enables the readout noise, which is an inherent part of the camera system, to be suppressed. This improves the Signal-to-Noise Ratio (SNR) of the instrument and allows much smaller signals to be detected.

Figure 6 shows the schematic of a generic EM-CCD. The image section, store section and readout register are the same as would be seen in a conventional frame transfer CCD. A multiplication register is added onto the CCD before the output node. This additional register allows the multiplication to occur before readout noise is added to the signal. The multiplication register works by accelerating the electrons in the charge packet through a large potential difference (~ 40 V). The accelerated electrons can then ionise other electrons in the silicon through impact ionisation, increasing the number of electrons in the charge packet and so increasing the signal.¹¹ This amplification applies to all of the electrons in the charge packet and so any dark current that has been integrated in the device will also be amplified. This has a negative effect on the noise level. This means

that, for EM gain to be most effective it is important to either run the EM-CCD cold (below -80° C) in order to suppress the dark current generation or, as dark current generation is time dependant, the device has to be read out quickly.

The gain, G , achieved by an EM-CCD is given by Equation 1, where g is the probability of an electron undergoing impact ionisation in one element of the multiplication register and N is the number of elements in the multiplication register (>500). This shows that even for a relatively small probability of impact ionisation (typically 0.015 %) the gain can be very large.

$$G = (1 + g)^N \quad (1)$$

The process has many advantages such as an increase in signal detectability, allowing much faster readout speeds, split event detection is improved and it creates noise immunity in the camera system (especially to Electro-Magnetic Interference, EMI); however, the multiplication does have an inherent noise associated with it that degrades the device energy resolution. The remainder of the paper will look at these advantages and disadvantages in order to assess the potential to use EM-CCDs in high resolution soft X-ray spectrometers.

4. DISADVANTAGES OF EM-CCDS

EM gain is a stochastic process, resulting in an additional component of noise being added to the signal causing a degradation of the energy resolution of the device. This section looks at why this energy degradation occurs and the effect that it would have on a high resolution spectrometer.

4.1 Modified Fano factor

The energy peak in silicon for X-ray detection is narrower in terms of Full-Width Half-Maximum (FWHM) than is predicted by Poisson statistics because the electrons that are initially generated by the photon interaction ionises further electrons through collisions in the silicon. Therefore, each of the generated electrons is dependent on the electrons generated before, and this dependence causes the shot noise associated with the interaction, and so the FWHM of the X-ray peak, to be narrower than predicted by Poisson statistics. The improvement seen is described by the Fano factor, f , (~ 0.115 in silicon).¹³ The Fano factor improves the noise on the X-ray detection, but an additional noise is added to the signal through the EM gain process. This noise has been described in optical applications as the Excess Noise Factor,¹² but due to the difference in detection caused by the Fano factor, it is described as the Modified Fano Factor in X-ray applications.¹⁴ The Modified Fano Factor has been shown to tend towards $(1 + f)$ in X-ray applications at high levels of gain and this increase in noise has to be taken into account when using EM-CCDs. For lower levels of gain the increase in noise is less than $(1 + f)$ tending to f at a gain of 1. This can be seen in Figure 7. The increase in noise leads to a degradation of the energy resolution of the device and, if it is being used to determine the energy of an incident photon for order separation, this degradation may have a significant impact on the instrument.

The Modified Fano Factor can be applied to a theoretical prediction of EM-CCD performance using the following equation:

$$FWHM = \sqrt{(8 \ln(2)) \left[\left(\frac{\sigma_{readout}}{G} \right)^2 + \sigma_{dark}^2 + F_{mod} \left(\frac{E}{\omega} \right) \right]} \quad (2)$$

where $\sigma_{readout}$ is the readout noise in the device, σ_{dark} is the amount noise associated with dark current generation, G is the level of EM gain, F_{mod} is the Modified Fano Factor, E is the energy and ω is the energy required to generate an electron-hole pair in silicon. If the device is running cold (below -80° C) then the dark current can be ignored. The Modified Fano Factor and its effect on energy resolution has been verified experimentally using ^{55}Fe in the lab.¹⁴ Figure 8 shows the increase in the FWHM of the X-ray peak with and without EM gain on the signal. In the X-ray peak with a gain of 10, the Modified Fano Factor causes the Mn K-beta peak to be poorly resolved and it is beginning to be overwhelmed by the K-alpha peak. This is indicative of the problem of the degradation of the energy resolution due to the use of EM gain.

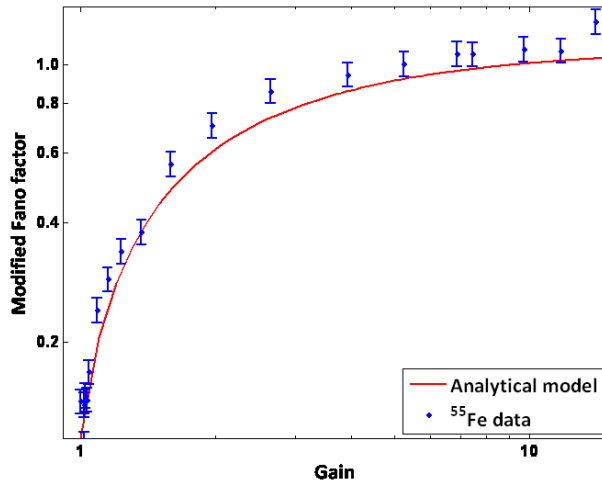

Figure 7. The effect that gain has on the Modified Fano Factor in silicon is shown. The line represents the theoretical model and the points are from data taken using an EM-CCD detecting Mn K-alpha emission from an ^{55}Fe source¹⁴

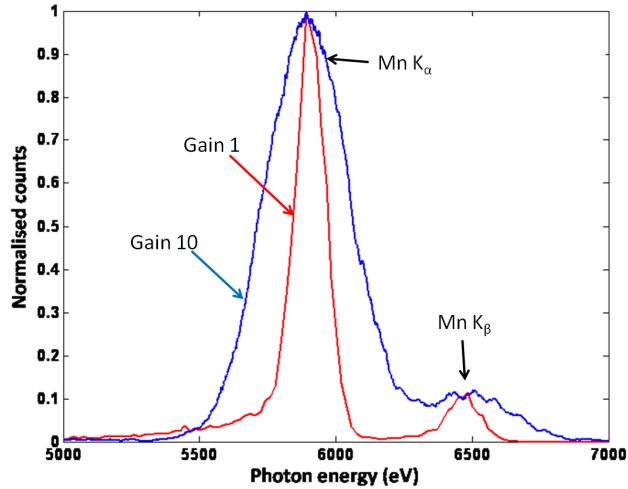

Figure 8. Mn K-alpha and K-beta X-rays detected by an EM-CCD at a gain of 1 and a gain of 10 showing the degradation in energy resolution that occurs when gain is used¹⁴

4.2 Degradation of energy resolution

The OP-XGS requires an energy resolution of 200 eV in order to differentiate between the different energies that would be detected at the same spatial position on the CCD array due to using overlapping orders as shown in Figure 4. Using data taken at 400 eV and 600 eV at BESSY⁹ the ability to separate these two energies can be assessed.

Figure 9 shows 400 eV and 600 eV X-rays with a gain of 7.7 on the same plot. Split events in the data have caused the X-ray peaks to be broader than predicted by theory, causing the Gaussians plotted to overlap by 8 %. This overlap produces an uncertainty in the energy of the incident photon that is unacceptable in a high resolution instrument. Two other Gaussians are plotted that match theory showing that, while there is no significant overlap, the two X-ray peaks are very close to each other, suggesting that the use of an EM-CCD using the current OP-XGS setup that requires a 200 eV energy resolution is not possible. This does not rule EM-CCDs out for high resolution soft X-ray spectrometers, but that instruments have to be designed to allow a larger energy separation between energies that are located at the same spatial location of the EM-CCD camera

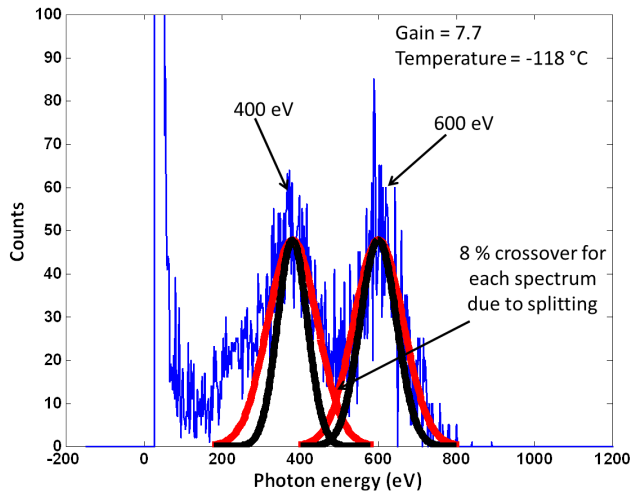

Figure 9. X-ray peaks for 400 eV and 600 eV at a gain of 7.7 demonstrating the energy resolution required for order separation to be possible

readout array.

5. ADVANTAGES OF EM-CCDS

Through the use of EM-CCDs, the signal can be amplified to a level that makes readout noise negligible, providing some inherent advantages such as enabling the device to be read out faster for a minimal increase in readout noise, improvements in X-ray detectability, increase in split event detection and noise suppression. These advantages are discussed in this section.

5.1 Noise vs. readout speed

In order to minimise the noise that is generated in a conventional CCD, CDS is implemented. This imposes limitations on the read out speed in order to allow sufficient time for the waveform to settle for the clamp and sample pulses, allowing a better average of the signal level to be made, removing the effect of reset noise and so providing a lower read noise; however, this method of readout is not always practical for all applications. If the CCD has to be run relatively warm or the flux of incident photons is high then a faster readout is necessary. This can lead to an increase in the noise of the system causing low energy events to be lost in the noise floor. EM-CCDs are able to amplify the signal before readout, hence the noise associated with reading out the device can be suppressed. Therefore, even if the device is read out faster, causing the noise floor to rise, the EM gain noise suppression means that this rise has a small effect on the data taken from the device, maintaining the ability to detect low signals as seen in Figure 10.

Since the device can be run faster, the low temperature requirement can be relaxed and the device can handle much higher flux levels. The faster readout speed possible could have been used to fix a problem with hot pixels seen on the RGS on XMM-Newton (shown in Figure 11).

Figure 11 shows the hot pixels that developed over time in the RGS CCD camera array due to radiation damage.³ In order to mitigate this problem the instrument team was able to decrease the temperature of the CCDs and the hot pixels disappeared. If the CCDs were EM-CCDs then the readout speed could have been increased and this would have had the same effect without the need of a temperature change.

5.2 Improvements in X-ray detectability

Low energy X-rays generate small numbers of electrons in the charge packet created through the photon interaction in the silicon causing the SNR to be small (300 eV generates ~ 82 electrons). Through the amplification

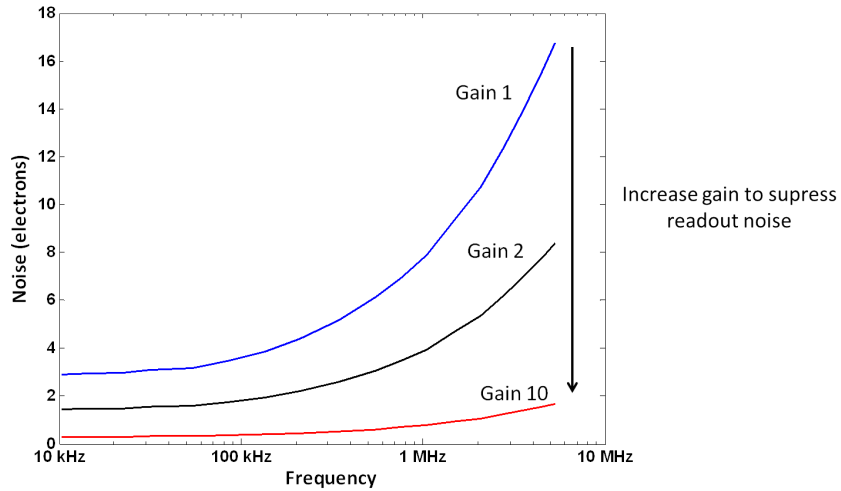

Figure 10. As the readout speed increase so does the associated readout noise; however, an EM-CCD is able to suppress this noise through the amplification of the signal¹⁵

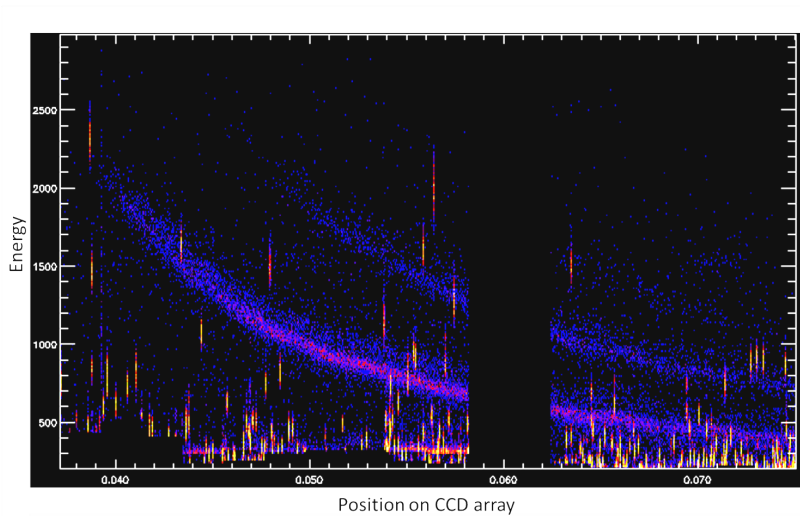

Figure 11. Spectra from the RGS on XMM-Newton showing hot pixels in the CCD camera array. The effect of these hot pixels can be minimised by making the CCD array colder or reading out the devices faster

of the number of electrons in the charge packet, the signal is multiplied to a much higher level than the noise, increasing the detectability of the photon interaction as shown in Figure 12.

Increasing the signal allows the interaction to be easier to see; however, its spatial position can only be identified with resolution limited by the pixel. Typically the charge packet splits over several pixels. Centroiding the split event can enable sub-pixel resolution to be achieved.

5.3 Increase in split event detection - centroiding

At low energies, few electrons are generated through the initial interaction and so if these electrons are then split across many pixels they will be very easy to lose in the noise. If an EM-CCD is used, even very small signal can be amplified above the noise floor of the device, allowing the extent of the split event to be identified and allowing for more accurate centroiding, improving the spatial resolution and so the overall resolution of the instrument improves. The amplification of the signal in the split events due to EM-gain is shown in Figure 13. Using this centroiding approach, sub-pixel spatial resolution is possible.¹⁶ Using the PoLuX instrument at PSI, an X-ray

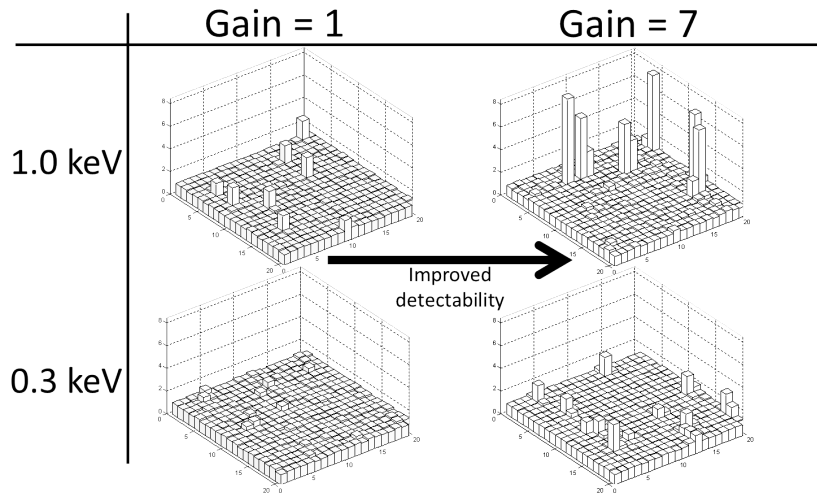

Figure 12. The increase in signal above the noise can be seen even for a relatively small level of gain. This effect is more pronounced at lower X-ray energies

spot can be focused to approximately 20 nm diameter levels and projected onto a CCD. Through rastering this spot across the CCD, the effect of where the X-rays hit within the pixel of a CCD can be measured. If this charge splits across many pixels, centroiding can be used to constrain the possible position that the X-ray interaction happened on the CCD.

5.4 Noise suppression - Electro-Magnetic Interference (EMI)

The left image in Figure 13 shows a pattern in the background. When EM gain is used, this pattern becomes less pronounced. This is the basis of noise suppression. When a CCD is read out the device can pick up interference from the surrounding electronics. This adds to the noise of the system and, while it can be removed through optimising the electronic setup, if EM gain is used then the effect of these patterns can be suppressed along with the readout noise.

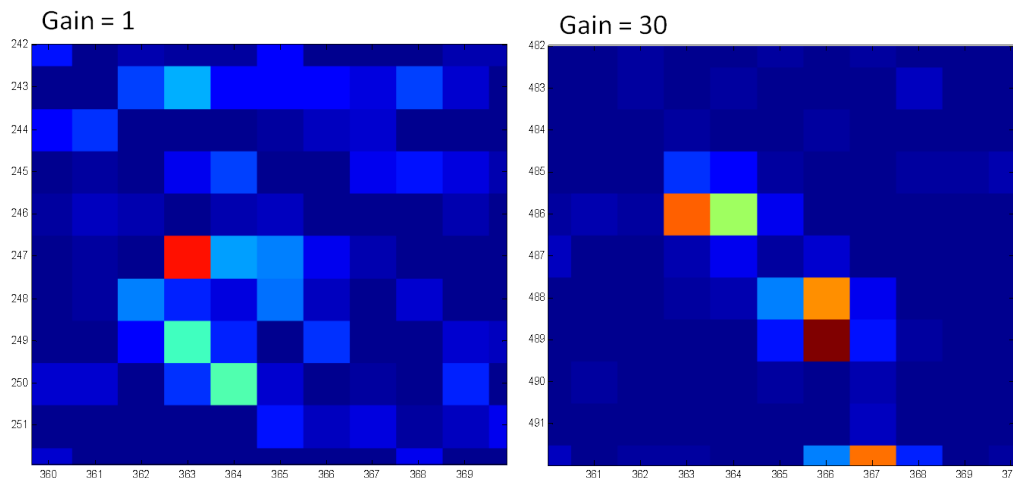

Figure 13. The signal on the image to the left is close to being lost in the background noise with a gain of 1. A gain of 10 (right image) is applied and the X-ray events (1 keV) are raised above the noise floor allowing the split events to be clearly seen

Two images from the RGS on XMM-Newton are shown in Figure 14. The upper image shows the readout from the CCDs with an EMI pattern across the CCDs that may affect the results. The lower image shows the energy that is collected across the CCDs. The lower energy photons to the right of the bottom image are close to the noise floor and could be confused with the EMI in the devices. Through the use of EM gain the amount of signal created by these photons could be increased, taking them away from the EMI on the noise floor.

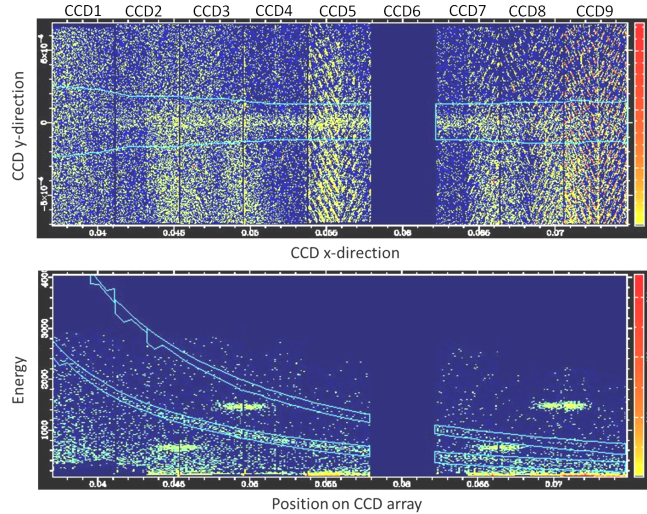

Figure 14. Spectra from the RGS showing an interference pattern. The use of EM-CCDs would move the spectra above the noise floor, negating the effect of this EMI

6. CONCLUSION

EM-CCDs have many advantages that would make them ideal detectors to be used in high resolution soft X-ray spectrometers. Their suppression of the readout noise of the system helps them to be immune to fluctuations in the noise floor such as Electro-Magnetic Interference. This suppression also allows the devices to be read out faster, allowing a higher frame rate and object to be observed with a higher flux without saturating the readout whilst maintaining the same read noise level. It also allows the devices run warmer for the level same dark current generation. The increase in signal also allows the SNR to be improved, making low energy events more easy to detect and means that the extent of any charge splitting that occurs in the device can be readily identified. This allows accurate centroiding to be achieved, improving the spatial resolution of the instrument. EM-CCDs would be especially useful on an experiment such as SAXES at PSI as the noise suppression that could be achieved would allow the instrument to be read out much faster and single photon counting, would become easier. More accurate centroiding is then possible due to the amplification of the split events and a higher spatial resolution for the instrument.

The major disadvantage of EM-CCDs is the additional noise that is generated through the EM gain process as described by the Modified Fano Factor. The increase in noise causes a degradation of the energy resolution of the device which, if the inherent energy resolution of the detector is required to separate different energies at different orders, could be problematic to the instrument.

EM-CCDs have the potential to be excellent detectors for high resolution soft X-ray spectrometers; however, the instrument has to be designed to allow for the degradation in energy resolution due to the use of EM gain. This is a predictable effect and so should pose no problem to future instrument designs.

ACKNOWLEDGMENTS

I would like to acknowledge the team at the PTB beamline at BESSY for their expertise and skill in helping me collect the data for this work. I would also like to acknowledge the members of the CEI at the Open University who were on hand to check my work for clarity, grammar and accuracy.

REFERENCES

- [1] Strocov V. N. et al., "Concept of a one-shot RIXS spectrometer for XFELS", *PSI Technical Report*, **No. SLS-SPC-TA-2009-319**, (2009).
- [2] Brinkman A., "The Reflection Grating Spectrometer on board XMM", *Proc. The First XMM workshop: Science with XMM, ESTEC, Noordwijk, The Netherlands*, (1998).
- [3] den Herder J. W. et al., "The Reflection Grating Spectrometer on board XMM-Newton", *Astronomy & Astrophysics*, **Vol. 365**, L7–L17 (2001).
- [4] Weisskopf M. C., "An Overview of the Performance and Scientific Results from Chandra X-ray Observatory", *Astronomical Society of the Pacific.*, **Vol. 141**, 1–24 (2002).
- [5] Ghiringhelli G. et al., "SAXES, a high resolution spectrometer for resonant x-ray emission in the 4001600eV energy range", *Rev. Sci. Instrum.*, **Vol. 77**, (2007).
- [6] Lillie C. F. et al., "The Warm-Hot Intergalactic Explorer (WHIMex) Mission Concept", *American Astronomical Society*, **Vol. 43**, (2011).
- [7] Barcons X. et al., "International X-ray Observatory (IXO) Assessment Sturdy Report for the ESA Cosmic Vision 2015-2025", (2011).
- [8] McEntaffer R. L. et al., "Developments of the Off-Plane X-ray Grating Spectrometer for IXO", *Proc. SPIE*, **Vol. 7732**, (2010).
- [9] Tutt J. H. et al., "A study of Electron-Multiplying CCDs for use on the International X-ray Observatory Off-Plane X-ray Grating Spectrometer", *Proc. SPIE*, **Vol. 7732**, (2010).
- [10] Murray N. J. et al., "Off-Plane X-ray Grating Spectrometer camera for IXO", *Proc. SPIE*, **Vol. 7742**, (2010).
- [11] Jerram P. et al., "The LLLCCD: Low light imagining without the need for an intensifier", *Proc. SPIE*, **Vol. 4306**, (2001).
- [12] Robbins M. S. et al., "The Noise Performance of Electron-Multiplying Charge-Coupled Devices", *IEEE Trans. Elect. Dev.*, **Vol. 5**, (2003).
- [13] Fano U., "Ionization Yield of Radiations. II. The Fluctuations of the Number of Ions", *Physical Review.*, **Vol. 72, No. 1**, (1947).
- [14] Tutt J. H. et al., "The Noise Performance of Electron-Multiplying Charge-Coupled Devices at X-ray energies", *IEEE Trans. Elect. Dev.*, (submitted 07/2011).
- [15] e2v CCD230-84 datasheet, *A1A-1000049*, **Version 3**, (2007).
- [16] Hall D. J. et al., "Improving the resolution in soft X-ray emission spectrometers through photon-counting using an Electron Multiplying CCD, *PSD9*, (submitted 07/2011).