

Location based transmission using a neighbour aware with optimized EIFS MAC for ad hoc networks

MARCHANG, Jims <<http://orcid.org/0000-0002-3700-6671>>, GHITA, Bogdan and LANCASTER, David

Available from Sheffield Hallam University Research Archive (SHURA) at:

<http://shura.shu.ac.uk/15842/>

This document is the author deposited version. You are advised to consult the publisher's version if you wish to cite from it.

Published version

MARCHANG, Jims, GHITA, Bogdan and LANCASTER, David (2017). Location based transmission using a neighbour aware with optimized EIFS MAC for ad hoc networks. *Ad Hoc Networks*, 63, 62-78.

Copyright and re-use policy

See <http://shura.shu.ac.uk/information.html>

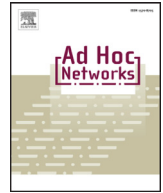

Location based transmission using a neighbour aware with optimized EIFS MAC for ad hoc networks



Jims Marchang^{a,*}, Bogdan Ghita^b, David Lancaster^c

^a Department of Computing, Sheffield Hallam University, UK

^b School of Computing, Plymouth University, UK

^c School of Computing, Plymouth University, UK

ARTICLE INFO

Article history:

Received 29 June 2016

Revised 31 May 2017

Accepted 1 June 2017

Available online 3 June 2017

Keywords:

Ad Hoc

Cross layer

MAC

Transmission power

QoS

Network saturation

ABSTRACT

In a typical Ad Hoc network, participating nodes have scarce shared bandwidth and limited battery life resources, so resource optimization and enhancing the overall network performance are the primary aims to maintain functionality. This paper proposes a new cross layer Medium Access Control (MAC) algorithm called Location Based Transmission using a Neighbour Aware with optimized Extended Inter-Frame Spacing (EIFS) for Ad Hoc Networks MAC (LBT-NA with optimized-EIFS MAC) that aims to reduce the transmission power when communicating with the next hop receiver based on node's location which is made available during node deployment. However, node mobility is not taken into account in the study of this paper. According to the algorithm the node dynamically adjusts its transmission power, if there is an active neighbour located beyond the communicating source and destination pair to avoid hidden nodes. The new protocol also defines an optimized EIFS when frame collision, frame error or frame capture takes place, in-order to maintain a fair channel access among the contending nodes. The proposed MAC also uses a modified range of random backoff values, based on the degree of contention unlike IEEE 802.11 series which uses a fixed random backoff value for fresh frames irrespective of the degree of contention. Simulation results indicate that in a random topology with a random source and destination, when the two sources are separated by a minimum distance of 200 m, the performance gain of power controlled MAC over IEEE 802.11b ranges from 30% to 70% depending on the type of traffics in the network and the degree of fairness ranges from 62% to 99.99% for a location based MAC with minimum power transmission, whereas LBT-NA with optimized-EIFS MAC secures fairness index ranging from 75% to 99.99%. Communication with a node that is 20 m away can save 40% of the battery life in comparison to the traditional transmission power MAC from 802.11b. The validation tests demonstrate that the proposed algorithm increases battery life and reduces the interference impact on shorter distance communication and increases the probability of parallel transmission. The proposed protocol also provides a scope for active nodes to transmit with a higher degree of probability, providing higher degree of overall network throughput in the environment and alleviate the starvation of hidden node by using Dynamic EIFS scheme.

© 2017 The Authors. Published by Elsevier B.V.

This is an open access article under the CC BY license. (<http://creativecommons.org/licenses/by/4.0/>)

1. Introduction

In a resource-constrained Ad Hoc networks, interference is a significant limiting factor in achieving high throughput. As the interference range is directly proportional to the transmission range, controlling transmission range of the active nodes dictates the density of parallel or simultaneous communication and subse-

quently the overall network performance. In such networks, using a large transmission range reduces the number of hops between the source and destination, so the per-flow throughput may be increased in absence of other contending data flows. However, it increases the overall interference level, so the chances of concurrent transmission in a shared channel are reduced. Thus, the overall network performance degrades when the number of active nodes increases. On the other hand, when the transmission range is low, the overall interference decreases but the number of hops between the source and the destination increases. As a result, the end-to-end per-flow throughput may decrease [1], but the reuse factor in terms of frequency and space increases, so the

* Corresponding author.

E-mail addresses: jimsmarchang@gmail.com, jims.marchang@shu.ac.uk (J. Marchang), bogdan.ghita@plymouth.ac.uk (B. Ghita), david.lancaster@plymouth.ac.uk (D. Lancaster).

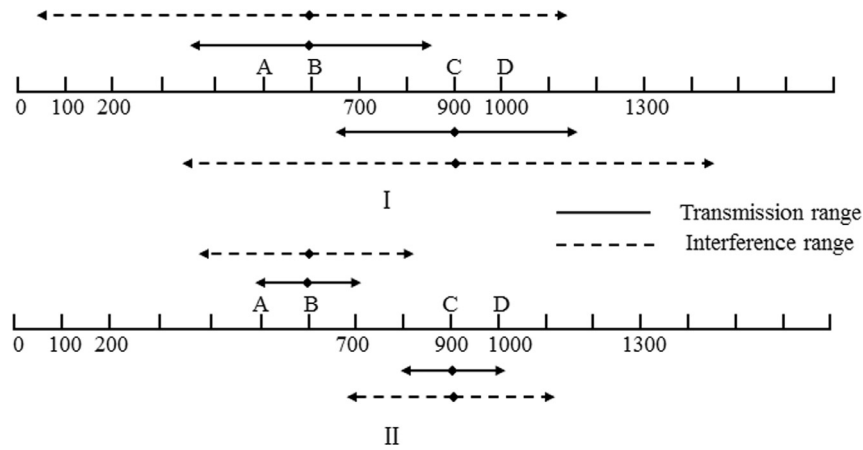

Fig. 1. Using a fixed transmission range (I) Using a location based power controlled transmission (II).

overall network performance will be increased due to the higher probability of concurrent transmission. Therefore, the paper aims to control the transmission power to reduce interference level and explore the probability of concurrent transmission to gain overall network performance. However, controlling transmission power may lead to higher degree of hidden nodes (which steers to unfair channel access) and unstable end-to-end connectivity when nodes are mobile. The other focuses of this paper include saving battery life and avoiding hidden nodes to maintain a high degree of fairness among contending flows when different transmission powers are used. Since the focus is not on end-to-end link connectivity and routing, mobility is not taken into account in this paper, but the work is focused on the MAC and the physical layer using a single hop communication to explore concurrent transmission, battery life and fairness. Some of the applications of static Ad Hoc could be random positioning of nodes during disaster management to communicate with the nearest neighbour, random deployment of nodes for sharing information with neighbourhood in a stationed battlefield, random deployment of nodes for site survey, deployment of random nodes in football field, mega Ad Hoc events in indoor or outdoor, city centres, train station or airport for a temporary emergency hotspot to mention few.

The authors of [2–4] designed variant of power control MAC for wireless Ad Hoc networks, and all the proposed mechanisms used a maximum transmission power for Request to Send (RTS) and Clear to Send (CTS) control frames and a minimum transmission power for Data and Acknowledgement (ACK) frames. While achieving their aim of reducing an interference range while sending Data frames, the proposed mechanisms have an inherent limitation, because the overall probability of concurrent transmission can extensively be affected, since RTS and CTS control frames are sent using high transmission power. Zhao et al. [5] used different approach in controlling transmission power by considering a set of power levels, starting with a low transmission power while discovering or sending data to the next hop node. If the next hop node is unreachable, a higher level of transmission power is considered until the next hop node is discovered or until it reaches the highest possible transmission power level, whichever is earlier. The limitation of such technique is that each node will try with different transmission power levels without knowing whether it will result in successful discovery or sending data to the next hop node.

Standard wireless communication is based on using a fixed transmission power irrespective of the communicating distance, which leads to using a higher than necessary transmission power when the communicating pairs are close to each other. Thus, in a scenario where communicating pairs are closer, using a fixed transmission power leads to a significant interference coverage and un-

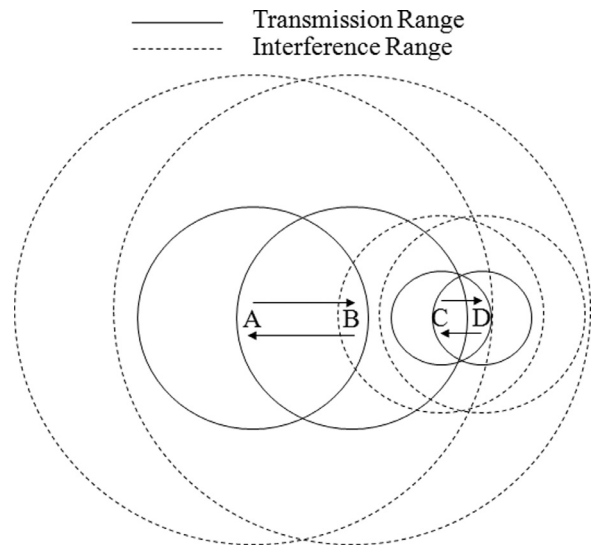

Fig. 2. Unfair access using minimal power transmission based on location.

necessary wastage of energy. As shown in Fig. 1(I), even though node A and node B are only 100 m away, when node B communicates with node A with a fixed high transmission power e.g. to cover 250 m, the activities of node C and node D are disturbed, so these nodes have to defer channel access when node B communicates with node A. On the other hand, considering the same network scenario with a power controlled communication based on the location of the nodes, as shown in Fig. 1(II), node B can send data to node A, while node C communicates with node D in concurrent. In such an approach, the area of interference decreases drastically, so the probability of concurrent transmission increases. Moreover, the overall lifespan of a node is expected to be increased, because node distribution in a network is random and communication between two nodes may not always require a high transmission power. However, communication using a fixed minimal power based on the location may also lead to an unfavourable situation of unfair channel access among the contending neighbourhood especially due to hidden nodes.

When two or more active neighbours use different transmission power, then the level of interference experience among the neighbourhood varies. A case where one node uses a higher transmission power and other neighbour node communicates using a low transmission power is shown in Fig. 2. In this network topology, node B and node C send data to node A and node D using a trans-

mission power P_1 and P_2 respectively, where $P_1 > P_2$ and distance $d_{A,B} > d_{B,C} > d_{C,D}$, where d_{ij} : distance between node i and node j . In this scenario, the following statements are valid.

- i. When node A is active, node C and node D are within its interference range and node A is out of the transmission range of nodes C and D, so they are hidden from each other.
- ii. When node B is active, node C is within its transmission range, but node D is still hidden and falls within B's interference range.
- iii. When node C or node D is active, only node B is disturbed because of the interference range of node C. Thus activities of node A and B hugely disturbed the activities of node C and node D compared to the interference produced by node C and node D upon node A and node B.
- iv. Node C is within node B's transmission range, but node B is out of the transmission range of node C. So, node B is not aware of node C even though node C is aware of the activity of node B. In such scenario, the paper aims to renegotiate the transmission power of node C while communicating with node D, so that node C is no longer hidden to node B. Thus, node B and node A communicate using transmission power P_1 , node C communicates with node D with a new power P_2' and node D communicates with the initial minimum power P_2 , where $P_1 > P_2 > P_2'$ to reciprocate with the distances $d_{A,B} > d_{B,C} > d_{C,D}$.

Even if the transmission power is adjusted to reduce the hidden node issues, all the hidden node problems cannot be resolved. Considering Fig. 2 again, it is clear that node D cannot adjust its transmission power since node D is not within the transmission range of other active neighbours except node C with which communication is taking place. In such a scenario, where a hidden node is silenced by other active nodes, an unfair channel access still persisted. In view of such issues, Kosek-Szot [6] surveyed the recent development of MAC protocols in terms of solving the hidden node issues. In Fig. 2 when node A or node B is active, node D can neither interpret who initiates the transmission nor the type of frames since it is out of their transmission ranges even though it lies within their interference ranges. In such situation, the standard carrier sensing IEEE 802.11 mechanisms defers channel access for a fixed EIFS, by assuming that the overheard transmission is an ACK frame although the frame could have been any other frame type. Li et al. [7] proposed an enhanced carrier sensing mechanism where deferring the channel access is based on observing the length of the frames and correspondingly identifying its type to provide fair access among the flows in the network, but the authors considered a fixed maximum data frame. In Fig. 2, if node A or node B is active, and in the mean time node D is receiving data from node C, the stronger signal should be captured instead of considering it as a collision and receive the data if it is intended for the node or defer channel access accurately based on the type of the overheard frame if it is not intended for the node. In such scenario of overhearing multiple signals, the IEEE 802.11 standard defers channel access for a fixed EIFS time. Li et al. [7] did not deal with the capture scenario where multiple signals are overheard at the same time.

The remainder of the paper is structured as follows. Detail surveys on transmission controlled protocols are discussed in Section 2 and the proposed MAC is described in detail in Section 3. Section 4 provides the discussion and the evaluation of the results, and finally Section 5 concludes the paper by proposing a number of future directions.

2. Transmission power control in ad hoc networks

Different approaches were investigated by various authors to reduce interference and improve the performance of the overall

network by controlling the transmission power. A power controlled MAC named POWMAC is discussed in [8] and [9], where the authors use the RTS and the CTS control frames for advertising the signal strength and it exchanges N number of RTS/CTS pairs for securing N concurrent transmissions. It also introduces an additional control frame and access windows to determine when to send the data concurrently. Thus, this approach involves a significant control overhead. In order to reduce the signalling burden, [10] proposed an adaptive power control MAC by using only the RTS and CTS for collecting transmission power of the active neighbours and interference level. In order to validate its claims, the study assumes that the transmission range and the carrier sensing range are identical, which is rather artificial as the carrier sensing range is typically greater than the transmission range. Such approaches use a maximum transmission power for RTS and CTS control frames, but use only the required power for Data and ACK frames, so the probability of collision is high at both the sender and the receiving ends. To reduce the degree of collision in such approaches, a new power controlled MAC is proposed in [11] which utilizes the fragmentation mechanism of IEEE 802.11 MAC and controls the transmission power based on the fragmentation technique. In this mechanism, all the RTS, CTS and ACK frames corresponding to fragmented data frames are sent with maximum transmission power except the last one, to reduce collision with the surrounding active neighbours. The limitation of this approach is that fragmentation does not occur unless the frame size reaches the Maximum Transfer Unit (MTU) of the link.

A cross layer technique combining scheduling, routing and power control transmission is proposed in [12], based on the Time Division Multiple Access (TDMA) mechanism. Using deterministic access in distributed Ad Hoc networks is highly challenging due to synchronisation issues when the number of the participating nodes in the network changes and allocating slots to nodes that have no data is inefficient. The authors of [13] presented that in an optimal power control mechanism approach, to improve spatial utilization, senders should not send with just enough power to reach the next hop node, but they should use a higher transmission power. A power control transmission based on the interference and distance estimation is designed in [14], but such an approach suffers from distinguishing the differences between the low power transmissions for short distances from high power transmission with long distances. Shih and Chen [15] proposed a collision avoidance MAC based on adjusting the power level of the source node, so that the active neighbour can withstand its interference level. A power control MAC mechanism, where control frames like RTS-CTS use maximum transmission power and the Data-ACK uses minimum power is designed in [16]. However, in this mechanism, periodically Data frames are sent using a maximum power, so that the neighbours within a sensing range can sense its activity to avoid nodes from being hidden. This approach saves energy mainly by sending Data-ACK with minimum transmission power, but the probability of introducing parallel transmission is significantly reduced because RTS-CTS are sent with maximum power. The nodes which are within a reception range of RTS-CTS generators will avoid transmission and wait for the necessary Network Allocation Vector (NAV) to avoid collision. To avoid such problems, Varvarigos et al. [17] designed a new method where the RTS messages are not sent with a constant maximum power. Instead, transmission starts with a lower transmission power which is also advertised in the message, but the CTS frames are sent with maximum power to alert any neighbours that have data to send. This may subsequently lead to varying transmission ranging from the same node, so active neighbours experience an uneven degree of interference, which may lead to unfair end-to-end throughput. Cui and Syrotiuk [18] introduced a mechanism where the transmission power is reduced based on the degree of contention by moni-

toring the contention window. A trade-off between the bandwidth, latency and network connectivity during transmission power control Ad Hoc networks is proposed in [19]. An energy aware adaptation for IEEE 802.15.4/ZigBee sensor networks is designed by Di Francesco et al. [20] to capture the reliability requirements of an application to automatically configure the MAC based on the network topology and traffic condition. Focusing on the transmission power control, the study presented in [21] suggests that obtaining an optimal transmission power is an NP-hard problem even if the node has the entire knowledge of the network and uses a deterministic approach to optimize the durability of the battery life.

Dang et al. [22] designed a power controlled transmission by sending control messages containing the transmission power information using a maximum transmission power in the Announcement Traffic Indication Message (ATIM) window while the data packets are sent at the minimum required transmission power during the data window and in this method by considering the sensing power or the transmission power information of the control messages a neighbour node checks to decide if it can transmit concurrently. In [23] the authors designed a transmission power mechanism which is adapted based on the estimated local vehicle density to change the transmission ranges dynamically and based on the collision rate the CW size is also adapted to enable service differentiation. By analysing the relationships among the transmission range, carrier-sensing range, and interference range under different transmission power strengths, Shih and Chen [24] designed frameworks to avoid hidden nodes created by the expansion of the interference range of the receiver due to the controlled transmission power of the sender by considering either the transmission range or carrier-sensing range of the sender or the receiver to cover the interference range of the receiver. When the transmission power is controlled then per node throughput can fluctuate depending on the activity of the neighbourhood. Liu et al. [25] studied the exact per node throughput capacity of a Mobile Ad Hoc Network (MANET) when the transmission power of each node is controlled to adapt to a specified transmission range. Some other authors worked on controlling the network topology by considering the interference level experienced by a node for a delay constrained mobile Ad Hoc networks and one such is designed by Zhang et al. [26].

This paper is an extension of the work carried out in [27] where location information is used to estimate the distance between the communicating nodes and uses only a minimum transmission power while communicating with the next hop. In such approach, due to the distributed nature of the nodes, the distances between the nodes vary and when a node communicates with the next hop using a higher transmission power due to longer distance, other neighbour nodes communicating with a shorter distance will be hidden. In such scenario, a node using a higher transmission power takes over the channel and the nodes communicating with a shorter distance starve due to interference.

When the transmission power is controlled, in order to reduce or avoid or solve the hidden node issues, this paper proposes two different mechanisms. Firstly, the proposed mechanism adjusts the transmission power if there are other active neighbours communicating with a higher power to avoid the hidden node issue. If there is no interfering active neighbour, a node uses a minimum transmission power. The detailed explanation on how to estimate an optimal transmission power is elaborated in Section 3.3. When transmission power varies based on the distance of communication, it is impossible to resolve all the hidden node issues by increasing or decreasing transmission power of the participating active nodes. Therefore, a node that falls within an interference range of other active node will always receive an erroneous frame and does not have any information about those active nodes. In such cases, deferring channel access for a fixed amount of time is never

accurate and a node within a sensing range of other active node is not aware of the frame transmission duration and when or how long the other nodes will be active. Thus, in the second approach in order to avoid hidden nodes, reduce collision during overhearing multiple signals and to ensure fairness when a node falls within an interfering range of others, a dynamic EIFS deferring technique is proposed rather than using a fixed EIFS while deferring during the busy state of a channel and the EIFS is based on the frame type and it is interpreted based on the duration of the busy state of the channel. The detailed explanation is elaborated later in Section 3.4. Moreover, when the transmission power is controlled based on the location of the nodes, the transmission coverage changes dynamically, so is the number of contenders within a transmission coverage. In order to save energy and enhance the network performance when less active neighbours are involved, a new backoff technique based on the degree of contention is designed in Section 3.5.

3. Power control cross layer

As highlighted by prior research, the transmission power does have a significant influence on the network capacity, particularly for relatively high node density, due to the high degree of transmission and interference area overlap. To reduce the impact of these issues, this paper proposes a new cross layer MAC called Location Based Transmission using a Neighbour Aware with optimized EIFS MAC for Ad Hoc Networks (LBT-NA with optimized EIFS MAC). The proposed protocol consists of three parts: firstly, calculating the power of transmission using location information by considering the optimal distance among the active neighbours; secondly, proposing an optimized EIFS based on the power calculations; lastly, implementing a new random backoff algorithm based on the number of active neighbour in order to enhance the utilisation of shared resources. The proposed power controlled cross layer MAC is described in the following subsections.

3.1. Assumptions of the wireless model

As described by Kotz et al. [28], this work also follows a simple wireless communication model with a perfect radio propagation channel as used in academic practice with the following assumptions:

- i. The surface of communication is flat.
- ii. A radio's transmission area is circular.
- iii. If node A can hear node B, then node B can also hear node A (symmetry), provided nodes don't move and use the same transmission power.
- iv. If node A can hear node B at all, node A can hear node B perfectly.
- v. Signal strength is a function of distance.

In addition, the proposed model also assumes that each node is aware of its current location with the help of a Global Positioning System (GPS). In the study a perfect radio propagation channel is considered. Each node is enabled with two propagation models namely Friis and Two Ray Ground. When a node communicates using Friis propagation model the effects of obstruction, reflection, refraction and scattering upon the signal are not considered, because it assumes that the communicating nodes lie within the line of sight as shown in Fig. 3(I). When the communicating distance is high the node considers the Two Ray Ground propagation model where both the reflected signal and the strong line of sight signal are taken into account, so that it can handle the issue of obstruction better as depicted in Fig. 3(II) compared to Friis model. Each node can switch from one propagation model to another based on the distance of communication. The detailed method on selecting the propagation model is described in Section 3.2. However, the

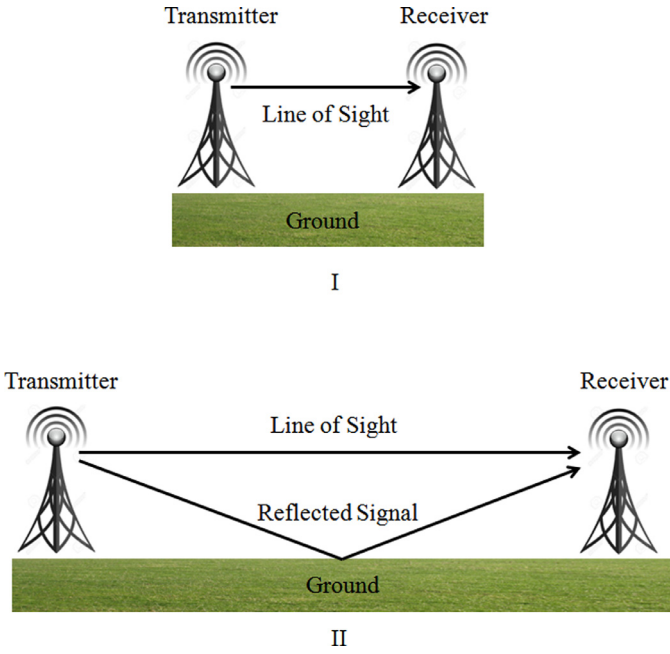

Fig. 3. (I) Friis propagation model (II) Two Ray Ground propagation model.

issue of shadowing i.e. field strength variations of the signal when the antenna is displaced for a large distance is not considered due to the assumption of a perfect channel condition, but channel fading over a distance is considered in both the propagation models. Moreover, in this study, only the interference caused by other active participating nodes of the network is considered, but the interference caused by other external environmental factors is not taken into account. In case of overhearing multiple signals, frame loss due to collision is considered unless one of the signals is ten times higher than the interfering signals. The mechanism uses a distance path-loss component, but the reception decision is based on the threshold of the receiving signal strength called $RXThresh$. In the study, the energy used by an active node when acquiring the location information is not taken into account mainly because node mobility is restricted and once the nodes are deployed continuous availability of location information is not necessary (unless the deployed nodes are mobile). Moreover, in this study, availing location information is a one-time event which happened during node deployment, so the dominant usage of energy utilisation takes place only during data communication. Lastly, the study also assumes that packets generated by any source are of same size and it is considered to be 1000 bytes during simulation.

3.2. Transmission power calculation

The proposed model does not use any additional control frames for exchanging location information, but new fields are introduced in the RTS and the CTS frames to exchange the location information between the source and the destination (an additional overhead of only $4 \times 2 = 8$ bytes each). Since the nodes are deployed in 2D environment, only the X-Axis and Y-Axis values are exchanged. When a node has a data to send, it starts by broadcasting an RTS frame at full power and the intended next hop receiver replies with a CTS control frame to reserve the channel. When the intended destination node N_D with coordinates $(X_D, Y_D, 0)$ receives an RTS frame from a Source node N_S which is located at $(X_S, Y_S, 0)$, it extracts the location information and calculates the corresponding Euclidian distance $d = \sqrt{(X_D - X_S)^2 + (Y_D - Y_S)^2}$ between the two nodes. Likewise, upon receiving a CTS frame, the source also calcu-

lates the distance between the two nodes. As a result, the source and the next hop destination are aware of the relative distance between them upon receiving the first RTS and the first CTS frames. Following the exchange of the first RTS/CTS frames, the rest of the control frames or the data frames are communicated using the newly estimated power based on the distance. The wireless model assumes a perfect channel condition; otherwise the newly calculated minimum power should be estimated to cover $d + \Delta$ to compensate the effect of shadowing and other signal attenuating path loss factors due to obstruction and the environmental condition.

One of the drawbacks of the newly calculated minimal power communication in a distance-based power controlled mechanism is that a pair of nodes communicating over a longer distance can seize the channel over its neighbours communicating with a shorter distance. On the other hand, those communicating over short distances in presence of longer distances can be starved due to high level of interference. In order to avoid such situations, when neighbour nodes are active, an optimized transmission power is estimated by considering the distances of all the active neighbours to reduce hidden node issues and provide fair contention among the competing nodes. The optimal distance of node i , $d_{optimal}^i = \text{Max}\{d_{i,q}\}$ where, $q = \{1, 2, \dots, k^{th}, \dots, N\} - \{i\}$, which are the active neighbours around node i .

$$P_t = \frac{P_r * (4 * \pi * d)^2 * L}{G_t * G_r * \lambda^2} \quad (1)$$

$$P_t = \frac{P_r * d^4 * L}{G_t * G_r * h_t^2 * h_r^2} \quad (2)$$

$$d_c = \frac{4 * \pi * h_t * h_r}{\lambda} \quad (3)$$

The transmission power is calculated using (1) when Friis propagation model is considered and it uses (2) for a Two Ray Ground propagation model. Friis propagation model is ideal for a short distance communication, since line of sight propagation is considered as discussed in [29–31] and these authors also mentioned that Two Ray Ground propagation model is efficient for a long distance communication due to consideration of the reflected ground signals as well as the line of sight signals. The authors also found out that, using Two Ray Ground propagation model is not favourable for short distance communication due to the oscillation caused by the constructive and destructive combination of the two signals arriving from the reflected ground and the line of sight. The cross-over distance is an approximation of the distance after which the received power decays with its fourth order of the communicating distance and the cross-over distance (d_c) is calculated using (3). In order to obtain an optimal performance, in this paper, Friis propagation model is used when the distance of communication is below the cross-over distance, and the system automatically switches to a Two Ray Ground propagation technique otherwise. The variables P_t and P_r of (1) and (2) represent the transmitted signal strength and the received signal strength respectively, when the communicating pair are separated by a distance called d . The antenna's transmitter gain, receiver gain, height of transmitter, height of receiver, frequency of the signal, wavelength of the signal and the system loss are represented by G_t , G_r , h_t , h_r , f , λ and L respectively. The algorithm for estimating the transmission power based on the distance of the communicating pair when the activities of the neighbours are taken into account is described in Table 1. The Two Ray Ground propagation model also has its own limitations in real life application in comparison to basic Freespace model like Friis as mentioned by Sommer and Drssler [32] introduced a new propagation model based on the phase difference of interfering signals and a reflection coefficient which yields a better result for an unobstructed communication between the sender and the receiver.

Table 1
Calculating an optimal transmission power.

F_{type} : Frame type	P_{rcv} : Received power strength.
f_c : Control frame	$O_{rts_cts}^{i \blacksquare k}$: Node i overheard either RTS or CTS frames from node k .
f_{rts} : RTS frame	
f_{cts} : CTS frame	ID_{gen} : Node ID of the frame/frame generator.
f_{ack} : ACK frame	
f_{data} : Data frame	$Orc_table^{i \blacksquare k}$: This table records the IDs and counts of node k when i overheard.
L_{frame} : Frame length	
$f_{routing}$: Routing frame	A_i^N : A table recording the active neighbour of node i .
$C_{rts}^{i \rightarrow j}$: Counting the number of RTS generated by active node i to j .	$A_{i_count}^N$: The number of active entry in A_i^N .
$C_{cts}^{i \rightarrow j}$: Counting the number of CTS generated by active node i to j .	$O_{dist}^{i \blacksquare k}$: Distance between the active node i and the overheard neighbour node k .
$R_{rts/cts}^{i \rightarrow j}$: Node i receives an RTS or CTS from node j	d_{max} : Maximum Distance of an active neighbour.
P_t^i : Power of transmission used by node i .	P_{est} : Estimated Power needed/used between the communicating pair.
P_r^i : Received power by node i .	OP_{est}^i : Optimal Power estimated to reach the farthest active neighbour node from i .
P_{max} : Maximum transmission power an active node can use.	$Table_{out}$: A table recording the IDs and P_t^i to whom the frame/frame is going out.
P_{thresh} : Minimum threshold power a node can receive successfully.	$Entry_{outCount}$: Count of the Table record of
$P_{min}^{i \rightarrow j}$: Minimum power required to communicate from node i to node j .	$Table_{in}$: A table recording the IDs and P_{est} from whom the frame/frame is arriving.
$d_{optimal}^i$: Farthest distance among all the active nodes within a transmission range of node i .	
d_{ij} : Distance between node i and j .	$Entry_{inCount}$: Count of the table record of $Table_{in}$
$P_{optimal}$: It's the power to reach the farthest active node within its transmission range.	
D_{ofk} : Destination of node k .	$O_p^{i \blacksquare k}$: Overheard signal power by i when k communicates with other nodes (say)
Dst_i : Destination of an active node i .	m .
If [$d_{optimal}^i < d_c$]	
$M = (4 * \Pi * d_{optimal}^i) / (\lambda)$	
$P_{optimal} = (P_{min} * M^2 * L) / (G_t * G_r)$	
Else	
$P_{optimal} = (P_{min} * (d_{optimal}^i)^4 * L) / (G_t * G_r * h_r^2 * h_t^2)$	

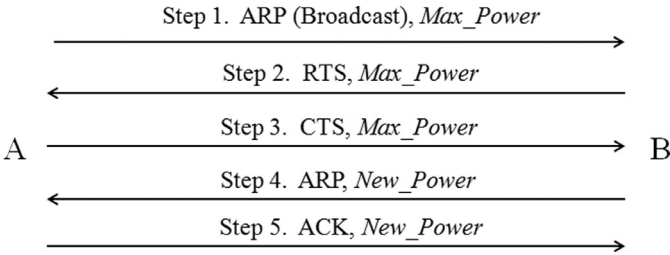

Fig. 4. Route discovery using DumbAgent.

3.3. Adjusting transmission power

Some of the symbols and terminologies used while calculating and adjusting the transmission power based on the distance and neighbour activity are listed below.

In order to limit the transmission range, every node is allowed to use a maximum standard transmission power (P_t) = 24.49 dBm, a power that can cover a maximum fixed transmission range of 250 m in a perfect channel condition. An interference range is always higher than that of a transmission range and in this paper, an interference range is considered to cover a radial distance of 2.2 times that of the transmission range as per the standards described in the NS2 simulator. Therefore, a node sending a data with a transmission power (P_t) generates an interference range up to 550 m. Thus, the threshold value of the signal strength to be considered within a transmission range and interfering range are -64.37 dBm and -78.07 dBm respectively.

This paper aims to analyse the spatial reuse and probability of parallel transmission in a single hop shared channel environment, so a routing protocol called DumbAgent is used since it sets up a link for a one hop communication and it works as shown in Fig. 4. Route discovery frames are always sent with maximum transmission power since the node has no information about the location until RTS/CTS frames are exchanged and it provides the highest probability of discovering the next hop neighbour. Thus, the trans-

mission power is adjusted depending on the type of the transmitted frame. In order to ensure their visibility and easily discoverable, initially RTS and CTS frames are sent with maximum power. Following a successful exchange of the first RTS and CTS frames all the future communication between the pair uses a reduced power, and in presence of multiple active neighbours, a new optimized transmission power ($d_{optimal}^i$) which reaches the overheard furthest active node is considered. The detailed algorithm on how the transmission power is adjusted based on the type of frame, activity of the neighbours and the communicating distance between the nodes is described in Table 2.

A record of the entire unique active nodes within the neighbourhood is recorded and maintained by each node through the overheard RTS and CTS control frames and the algorithm of maintaining the record is described in Table 3. Each active node i maintains a table called $Orc_table^{i \blacksquare k}$, and this table records all the overheard nodes (say) k when k communicates with another node m . The activity of the neighbour information is updated after every interval of T seconds and here $T = 1$ s is considered. During updating the active neighbour table, the algorithm removes any records with a timestamp older than a threshold T seconds. The neighbour table updating algorithm is shown in Table 4 and it is done in order to maintain the freshness of the network condition and remove any stale entries of inactive neighbours. In order to avoid searching for the optimal $d_{optimal}^i$ from the list of active table entry when needed, the optimal distance of the node i , i.e. $d_{optimal}^i$ is calculated while updating the neighbourhood record to reduce computation overhead.

3.4. Optimized EIFS

To tackle an accurate deferring when a frame is erroneous or when a strongest signal is captured among multiple overheard signals, the paper proposes an optimized Extended Inter-Frame Spacing (EIFS) rather than using a fixed EIFS by considering and observing the frame types and its sizes. The proposed algorithm aims to

Table 2
Algorithm for adjusting the transmission power.

When node i wants to send data to node j

```

If [ $F_{type} == f_{rts}$  ||  $F_{type} == f_{cts}$ ]
  If [ $C_{rts}^{i \rightarrow j} == 1$  ||  $C_{cts}^{i \rightarrow j} == 1$ ]
    If [ $R_{rts/cts}^{j \rightarrow i} == \text{Yes}$ ]
      If [ $d_{optimal}^i > d_{ij}$ ]
         $P_t^i = P_{optimal}$ 
      Else
         $P_t^i = P_{min}^{i \rightarrow j}$ 
    Else
       $P_t^i = P_{max}$ 
  Else
    If [ $d_{optimal}^i > d_{ij}$ ]
       $P_t^i = P_{optimal}$ 
    Else
       $P_t^i = P_{min}^{i \rightarrow j}$ 
  Else if [ $F_{type} == f_{ack}$ ]
    If [ $d_{optimal}^i > d_{ij}$ ]
       $P_t^i = P_{optimal}$ 
    Else
       $P_t^i = P_{min}^{i \rightarrow j}$ 
  Else if [ $F_{type} == f_{data}$ ]
    If [ $d_{optimal}^i > d_{ij}$ ]
       $P_t^i = P_{optimal}$ 
    Else
       $P_t^i = P_{min}^{i \rightarrow j}$ 
  Else if [ $F_{type} == f_{routing}$ ]
    If [ $R_{rts/cts}^{j \rightarrow i} == \text{Yes}$ ]
      If [ $d_{optimal}^i > d_{ij}$ ]
         $P_t^i = P_{optimal}$ 
      Else
         $P_t^i = P_{min}^{i \rightarrow j}$ 
    Else
       $P_t^i = P_{max}$ 

```

Table 3
Algorithm for collecting active neighbour information.

When node i overhears node k communicating to node m

```

If [ $F_{type} == f_{rts}$  ||  $F_{type} == f_{cts}$  &&  $O_{rts\_cts}^{i \rightarrow k} == 0$ ]
   $Orc\_table^{i \rightarrow k}[0].ID_{gen} = Src\_ID$ 
   $Orc\_table^{i \rightarrow k}[0].Count = 1$ ;
   $O_{rts\_cts}^{i \rightarrow k} ++$ ;
Else if [ $F_{type} == f_{rts}$  ||  $F_{type} == f_{cts}$  &&  $O_{rts\_cts}^{i \rightarrow k} > 0$ ]
  For [ $t=0$ ;  $t < O_{rts\_cts}^{i \rightarrow k}$ ;  $t++$ ]
    If [ $Orc\_table^{i \rightarrow k}[t].ID_{gen} == k$ ]
       $Orc\_table^{i \rightarrow k}[t].Count ++$ ;
      If [ $Orc\_table^{i \rightarrow k}[t].Count > 1$ ]
        If [ $A_{L\_count}^i == 0$ ]
           $A_i^i[0] \leftarrow \{T_{recv}, k, m, X_k, Y_k, O_{dist}^{i \rightarrow k}\}$ 
           $NAV_k, O_{rts\_cts}^{i \rightarrow k} ++$ 
           $A_{L\_count}^i ++$ 
        Else
          For [ $u=0$ ;  $u < A_{L\_count}^i$ ;  $u++$ ]
            If [ $A_i^i[u].From_{rts\_cts} == k$  &&  $A_i^i[0].To_{rts\_cts} == m$ ]
               $A_i^i[u] \leftarrow \{T_{recv}, k, m, X_k, Y_k, O_{dist}^{i \rightarrow k}\}$ 
               $NAV_k, O_{rts\_cts}^{i \rightarrow k} ++$ 
              Break;
            Else If [ $u+1 == A_{L\_count}^i$ ]
               $A_i^i[u] \leftarrow \{T_{recv}, k, m, X_k, Y_k, O_{dist}^{i \rightarrow k}\}$ 
               $NAV_k, O_{rts\_cts}^{i \rightarrow k} ++$ 
               $A_{L\_count}^i ++$ 
            Else
              Continue;
          Break;
    Else
      If [ $t+1 = O_{rts\_cts}^{i \rightarrow k}$ ]
         $Orc\_table^{i \rightarrow k}[t+1].ID_{gen} = k$ 
         $Orc\_table^{i \rightarrow k}[t+1].Count = 1$ ;
         $O_{rts\_cts}^{i \rightarrow k} ++$ ;
      Else
        Continue;

```

Where, $O_{dist}^{i \rightarrow k} = \sqrt{(X_k - X_i)^2 + (Y_k - Y_i)^2}$

Table 4
Algorithm for updating the neighbour information.

```

Initialised:  $d_{max} = 0$ ;
For [ $p=0$ ,  $q=0$ ;  $p < A_{L\_count}^i$ ;  $p++$ ]
  If [ $(A_i^i[p].T_{recv} + Interval) \geq Now$ ]
     $Temp\_Record[q] \leftarrow A_i^i[p]$ 
     $q++$ ;
  If [ $p+1 == A_{L\_count}^i$ ]
    For [ $r=0$ ;  $r < q$ ;  $r++$ ]
       $A_i^i[r] \leftarrow Temp\_Record[r]$ 
      If [ $d_{max} < A_i^i[r].O_{dist}^i$ ]
         $d_{max} = A_i^i[r].O_{dist}^i$ ;
     $d_{optimal}^i = d_{max}$ ;
     $A_{L\_count}^i = q$ ;
  Where,
  Each record entry of  $A_i^i$  consists of  $\{T_{recv}, k, m, X_k, Y_k, O_{dist}^{i \rightarrow k}\}$ 
   $\{NAV_k, O_{rts\_cts}^{i \rightarrow k} ++$ 

```

use an accurate deferring time by predicting the type of the frames by estimating the length of the arriving frame.

When a node (say) i is within an interfering range of other active nodes, then it defers EIFS channel access time since it fails to decode the erroneous overheard signal. Even when node i is within a transmission range of other nodes, but if it fails to rectify an erroneous frame using Forward Error Correction (FEC), then node i waits for EIFS time before attempting to access the channel again. When a frame is erroneous, it is not possible to know the type of frames directly, so IEEE 802.11 standards use a fixed time ($EIFS = SIFS_{time} + DIFS_{time} + Tx_Time_{ack}$) to defer channel access. Moreover, deferring channel access for a fixed time by considering that the overheard signal or received erroneous frames as an acknowledgement frame is not accurate, because it could have been any frame type. Therefore, randomly fixing a deferring time without the knowledge of the frame type can lead to an imprecise deferring because without having the information of the type or size of the frames, deferring time will never be accurate and it is one of the motivations behind designing an optimized EIFS instead of using an inaccurate fixed EIFS to ensure an accurate deferring time. In fact, in such situation hidden nodes may starve and lead to an unfair channel access during contention, if a fixed inaccurate deferring EIFS time is used.

On the other hand, when a node senses activity from two or more nodes at the same time, then before the frames are considered to be lost due to collision, the signal strength of the incoming signals are compared to check if one of the signals outstands the background interfering noise. In this paper, when one of the receiving signals is ten times stronger than the other, then the frame is received rather than dropping i.e. when SINR (Signal-to-Noise Ratio) = 10/1 otherwise frames are considered to be collided and are ignored. Such phenomenon is known as frame capturing and a capture threshold is denoted by CPT_{thresh} . If the captured (received) frame is not intended for node i , the node defers the channel access for a fixed EIFS time in IEEE 802.11 standards. However, out of the multiple overheard signals, if one of the frame's signals reaches signal strength of CPT_{thresh} then the node should not defer channel access using a fixed EIFS time, rather it should defer based on the type of the captured frame, which is the other aspect of proposing a dynamic and an optimized EIFS.

When frames are erroneous, it is hard to determine the type of a frame directly. However, in such situation, it is possible to indirectly determine the type of a frame, if the length of a frame can be measured. Such approach is applicable; if the frame lengths are unique otherwise it will be ambiguous for those frames which have same frame length. Once the route is established, types of frames participating in the communication are RTS, CTS, Data and ACK. In this paper, due to embedding location information and

Table 5
Defer channel access during frame error.

Switch(L_{frame})
CASE 38:
f_{ack} // This is ACK frame
Optimized $EIFS_{ack} = DIFS_{time}$
Break
CASE 52:
f_{rts} // This is RTS frame
Optimized $EIFS_{rts} = SIFS_{time} + Tx_Time_{cts}$
Break
CASE 56:
f_{cts} // This is CTS frame
Optimized $EIFS_{cts} = SIFS_{time} + Tx_Time_{data}$
Break
Default:
f_{data} // This is DATA frame
Optimized $EIFS_{data} = SIFS_{time} + Tx_Time_{ack}$
Break

Data size information in the control frames, the sizes of these frames are unique. The size of an ACK is 38 byte. In the RTS frame additional location information is embedded, so the size of the frame is 52 bytes and the size of CTS frame is 56 bytes since it carries location information as well as the length of the data frame it received. In order to calculate the frame length within a carrier sensing range, a node can sense the busy state of the channel by using the CS (Carrier Sense)/CCA (Clear Channel Assessment) mechanism within PLCB (physical layer convergence protocol) [33]. Here in this paper, CS sensing method is used to measure the frame length by measuring the busy state of the channel. Initially the RTS receiver or CTS generator or those nodes which overhears corrupt RTS/CTS knows nothing about the length of the data frame, so the overhearing nodes assumed that the data frame size is 1000 bytes. However, after the exchange of first round of RTS-CTS-DATA-ACK is completed, the actual data frame length is estimated successfully even by those nodes which overhear corrupt RTS/CTS by sensing the duration of the busy state of the channel to evaluate the frame length and interpret the frame types. Since the frame sizes of RTS, CTS, and ACK are unique and are known, any frame size larger than any of them can be assumed as a Data frame. When multiple nodes are active, then the signal with higher magnitude is compared with the background interfering noises to check if it satisfies $CPTresh$ to capture the frame before dropping.

When data communication takes place between nodes i and j , the control and data frames are exchanged in an order of RTS-CTS-Data-ACK as mentioned earlier. Since the handshaking pattern of the frame communication is the same, if a frame type is interpreted accurately within a sensing range based on the frame length then the node can accurately defer channel access using an optimized EIFS as described in Table 5. When the interpreted erroneous frame is an ACK (frame length of 38bytes) using the mentioned CS sensing method, then the node waits only for $DIFS_{time}$, because the contention for the next round is for a fresh frame and it can also participate. However, when the erroneous frame is of 52 bytes, then it is marked as a RTS frame and the node has to wait for $SIFS_{time} + Tx_Time_{cts}$, because the next frame is a CTS frame. When the erroneous frame length is 56 bytes in length, then being a CTS frame the node needs to defer for $SIFS_{time} + Tx_Time_{data}$, and if it is the first erroneous overheard CTS frame then the data frame length is not known yet, so the default data frame length is considered. Lastly, when the erroneous frame is neither RTS or CTS or an ACK then it is considered to be a data frame and defers for $SIFS_{time} + Tx_Time_{ack}$, so that the ACK generator is allowed to transmit with a higher priority.

During a frame capture situation when multiple signals are involved, if the receiving node i captures the frame and the destina-

Table 6
Access defer during frame capturing.

Switch(F_{type})
CASE f_{rts} :
Optimized $EIFS_{rts} = (3 * SIFS_{time}) + Tx_Time_{cts} + Tx_Time_{data} + Tx_Time_{ack}$
CASE f_{cts} :
Optimized $EIFS_{cts} = (2 * SIFS_{time}) + Tx_Time_{data} + Tx_Time_{ack}$
CASE f_{ack} :
Optimized $EIFS_{ack} = DIFS_{time}$
Default:
Optimized $EIFS_{data} = SIFS_{time} + Tx_Time_{ack}$

tion of the frame is node i , it responds to the sender in accordance with the four way handshaking principle i.e. if the captured frame is RTS then node i replies with a CTS frame and so on, otherwise it defers the channel access as mentioned in Table 6. If the captured frame does not meet the threshold value of $CPTresh$, the frame is considered lost due to collision. Since, the successfully captured frames are received without any errors even if it's not intended for node i , it knows the source and the destination, type of the frames, exact size of Data frame and so on, so deferring during channel access can be conducted accurately with precision. If the captured frame is RTS and is not intended for node i then it waits for the RTS generator to complete the sending of the following CTS, Data and ACK. Likewise, if the captured frame is a CTS then node i waits for the successful transmission of the Data frame and the ACK frame and if the captured frame is a Data frame then it waits for the completion of a transmission of an ACK frame. However, when the captured frame is an ACK then it waits only for $DIFS_{time}$, so that node i can also participate in contending for accessing the channel during the next round. Thus, using an optimized EIFS ensures channel access fairness despite encountering hidden nodes with erroneous frames or during a captured phenomenon.

3.5. Proposed exponential backoff mechanism

The working principle of the proposed backoff model is similar to that of IEEE 802.11 series which uses CSMA/CA approach. However, instead of providing same set of initial backoff ranges irrespective of the network condition in the proposed model, the initial backoff values are controlled dynamically based on the degree of contention i.e. the contention window is controlled by the number of active neighbours. When a packet is retransmitted then the backoff values are exponentially increased with reference to the initial backoff ranges. In a distributed environment, the degree of contention is not directly dependent on all the neighbour nodes; rather it depends only on the neighbour nodes which are active. Thus, when the channel is busy, it is safer for the node which has a data to send to backoff with a smaller value if the number of active neighbours is less, because the chances of collision are high only when the number of active nodes is high. Therefore, every active node in the network records the number of active neighbours in a variable (C_d), which indicates the level of contention within a neighbourhood. In this study, only three levels of contention i.e. LOW ($C_d = 0$), AVERAGE ($C_d = 1$) and HIGH ($C_d = 2$) are considered. The level of contention $C_d = 0$, if no other active nodes are detected (other than the next hop node responding with an ACK), $C_d = 1$ for up to two active nodes within the transmission range, and $C_d = 2$, if there are at least three active nodes within the transmission range. The degree of contention (C_d) and number of retransmission attempts (r) control the rate of increase for the contention window size, as shown in (4). A frame with $r = 0$ is considered to be a fresh packet and when $r \geq 1$, then the frame is

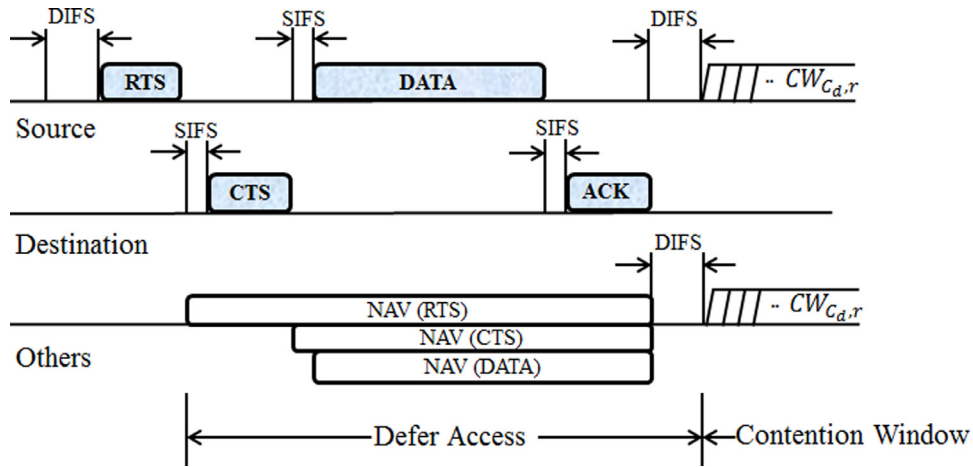

Fig. 5. Channel access mechanism.

known as a retransmitted frame.

$$CW_{C_d, r} = \begin{cases} 2^{(3+C_d)} - 1; & r = 0 \\ 2^{(3+C_d+r)} - 1; & r \geq 1 \end{cases} \quad (4)$$

Where : $C_d = \{\text{Low} = 0, \text{Average} = 1, \text{High} = 2\}$

$r = \{0, 1, 2, \dots, 7\}$

The access mechanism follows a four way handshaking as shown in Fig. 5 in order to successfully deliver a data frame from a source to a next hop destination. As mentioned earlier this model follows the basic principle of IEEE 802.11 series with RTS and CTS frames except for the backoff mechanism. When the channel is busy, other nodes which lie within the transmission ranges of the source and the destination nodes wait for NAV to avoid data collision. After a data frame is successfully acknowledged then during the next round of contention, all the contending nodes back-off the channel access based on the rule set by (4) and the node whose countdown first hit zero gets the chance to access the channel while the other contenders freezes their backoff values until the channel becomes idle again. This technique is followed in order to avoid starvation and ensure fairer channel access among the contending neighbours.

Since wireless channel is erroneous in nature, frame retransmission is taken into account, however only a finite number of attempts i.e. seven times are allowed to maintain frame's freshness. When frame retransmission takes place, if the frame could not be delivered after retrial limits then the frame is considered lost by dropping. During contention, it is the random backoff which helps in reducing the probability of collision. When the number of contending nodes is few, there is no need of choosing a large random backoff value, but during higher degree of contention, it is necessary to choose a random backoff from a larger range to avoid frame collision. When accessing a channel, fresh frame with no other active neighbourhood has a low probability of collision unless some neighbour node becomes active during its frame transmission, so a low backoff range i.e. 0–7 is considered. In a case where there is higher number of active neighbours the probability of collision is high, so a higher backoff range of 0–16 and 0–31 are considered for fresh frames when the level of contention is $C_d = 1$ and $C_d = 2$ respectively. If frame collision occurs and frame retransmission (when $r \geq 1$) has to take place, the ranges of the backoff values are increased according to the level of contention as shown in (4). Thus, this approach helps the contending nodes to choose dynamic ranges of backoff values based on the activity of the neighbourhood and enhances the network performance and saves energy especially when the number of active surrounding nodes is few.

4. Evaluation and discussion

The proposed cross layer power controlled MAC was tested in different scenarios and benchmarked against the IEEE802.11b and a Location Based Transmission Neighbour Aware Cross Layer MAC (LBT-NA Cross Layer MAC) [27]. The comparison examined the transmission power efficiencies of the power control mechanisms against the fixed transmission power mechanism. Through rigorous simulations, the mentioned mechanisms check the viability of concurrent transmissions and how hidden nodes are removed by negotiating the transmission power based on neighbour activity and using an optimized EIFS to provide fair channel access among the participating nodes. In addition, the evaluation also considered the impact of battery life and the effectiveness of the new backoff values used by the proposed MAC and tested the robustness of the protocol by considering random positions of the nodes with different traffic types including Constant Bit Rate (CBR), Transmission Control Protocol (TCP) and Exponential traffic.

All simulations were carried out with NS2, version 2.35 with the network parameters listed in Table 3. The values of the antenna parameters of G_t , G_r , h_t , h_r , f and L are 1.0 dBd, 1.0 dBd, 1.5 m, 1.5 m, 914.0×10^6 Hz and 1.0 respectively. Duration of each round of simulation lasts 1000 seconds and resultant value is an average of 100 rounds of simulations for all the cases.

4.1. Energy usage

Given that LBT-NA with optimized-EIFS MAC is a power control communication mechanism, the overall network performance gain and energy saving are significant when the communicating nodes are closer. In order to study the impact of energy usage during transmission of active nodes, an initial set of experiments used two communicating nodes positioned at a distance between 20 m and 250 m. Initially, the distance of communication is set to 20 m and repeats the simulation by initializing the node's energy to 1000J and increasing the distance of communication by 10 m until the distance of communication is 250 m. During the test, some additional network parameters are considered in addition to the network parameters listed in Table 7. In general, if a node is in a sleep mode, then the amount of power consumed in a second is 0.001 W. When a node goes to an idle state from a sleep state it requires 0.2 W and the time required to wake up is 0.005 s. But in this paper, no node goes in to sleep mode. The transmission power of a node for LBT-NA Cross Layer MAC and LBT-NA with optimized-EIFS MAC is adjusted as per the location of the destination node, in contrast with the standard IEEE 802.11b that uses a standard fixed

Table 7
Network simulation setup.

Parameter	Value/protocol used
Grid size	2000 m x 2000 m
Routing protocol	DumbAgent
Queue type	DropTail
Queue size	100
Bandwidth	2 Mbps
SIFS	10 μ s
DIFS	50 μ s
Length of slot	20 μ s
Default power (P_t)	24.49 dBm
Default $RXThresh$	-64.37 dBm
Default $CSThresh$	-78.07 dBm
$CPThresh$	10.0
Max_{Retry}	7
Simulation time	1000 s
Traffic type	CBR/TCP/exponential
Frame size	1000 bytes

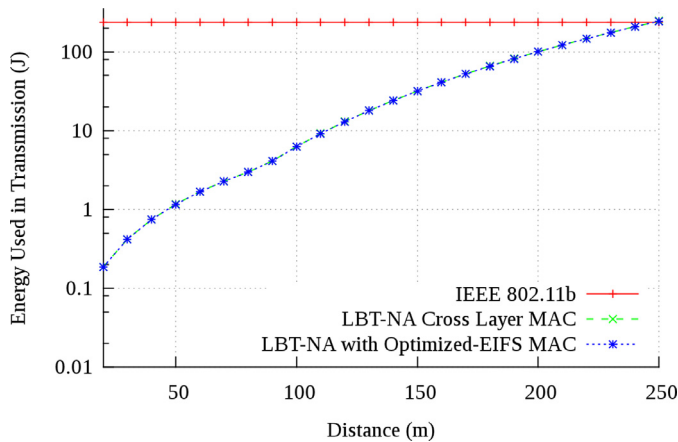

Fig. 6. Energy used by a source node during RTS and Data transmission.

transmission power of 24.49 dBm. The energy used by the source node and the next hop destination node is studied in the following subsection.

4.1.1. Energy utilization as the source

As shown in Fig. 6, as the distance of communication increases, the energy consumed by the source increases in both the location based power controlled MAC LBT-NA Cross Layer MAC and LBT-NA with optimized-EIFS MAC unlike IEEE 802.11b, where the power usage remains high and constant irrespective of the distance. A constant amount of 240J of energy is used when a source node continuously participates in sending data for 1000 sec when a fixed power transmission IEEE 802.11b is considered. Until the transmission range between the communicating nodes reaches 100 m, the amount of energy used in transmission by the source node in LBT-NA Cross Layer MAC and LBT-NA with optimized-EIFS MAC is under 10J. The increase in the energy usage as the distance increases is due to the fact that the signal strength fades by an order of d^2 or d^4 depending on Friis or Two Ray ground propagation model. So, the transmission power has to be increased to compensate the loss of the attenuated signal to maintain $RXThresh$. Thus, location based power control MAC is very efficient for a low distance communication and in the worst case scenario, it is as good as the standard IEEE 802.11b in terms of energy utilization. Irrespective of the distance of communication, there is a gain of approximately 2% in end-to-end throughput for the location based power controlled MAC due to deferring with small backoff values when there are less or no active neighbours.

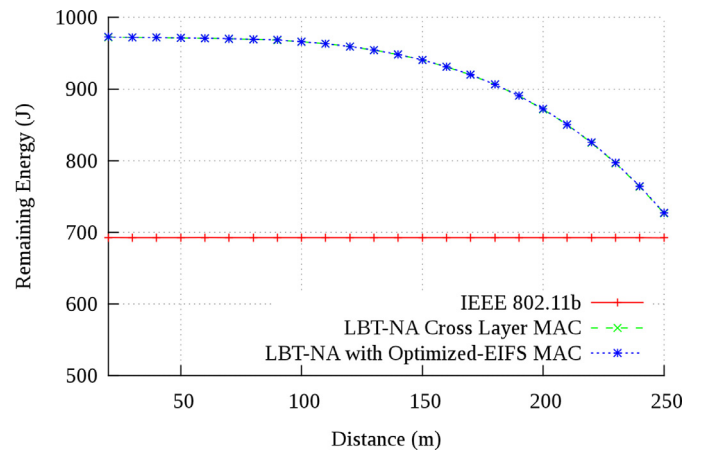

Fig. 7. Total remaining energy of a source node over distance.

An actively participating node spends energy either in receiving mode or transmission mode, contention mode or sensing mode, sleep mode or idle mode. During contention, an active node defers channel access using a random backoff value to avoid collision, where a node in such state is considered to be in an idle mode. The amount of energy used in such mode by a source node using IEEE 802.11b is approximately 2.6 times higher to that of LBT-NA Cross Layer MAC and LBT-NA with optimized-EIFS MAC, when the distance of communication is near i.e. 20 m or far i.e. 250 m. When contention is low, both the power controlled MAC save approximately 60% of energy during idle state compared to nodes using IEEE 802.11b access mechanism. It means that the source mode is less idle in case of LBT-NA Cross Layer MAC and LBT-NA with optimized-EIFS MAC compared to IEEE 802.11b due to use of a small backoff value when the contention level is low.

After each round of simulation, the amount of energy used or the level of remaining energy of a source node is shown in Fig. 7. This Fig. 7 also reflects the total amount of energy spent by the source node when it conducts sensing, sending of RTS and Data frames, reception of CTS and ACK, sending/reception of any other frames like routing frames and energy spent during deferring or backoff. The overall total amount of the remaining energy is very high in the case of LBT-NA Cross Layer MAC and LBT-NA with optimized-EIFS MAC compared to IEEE 802.11b. When the communicating distance is below 100 m, the total amount of energy spent by the source in LBT-NA Cross Layer MAC and LBT-NA with optimized-EIFS MAC is approximately only 5% of the battery life. But, in case of IEEE 802.11b, irrespective of the distance, the source node uses 30% of the battery life due to the use of a fixed high transmission power. Thus, in a short distance communication, the power controlled MAC uses only 1/6th of the amount of energy used by IEEE 802.11b, which is a huge advantage in enhancing the durability of the battery life. Even when the communicating distance is 250 m, LBT-NA Cross Layer MAC and LBT-NA with optimized-EIFS MAC save approximately 4% of energy compared to IEEE 802.11b because of the use of small deferring backoff values when the contention level is low.

4.1.2. Energy utilization as the destination

The destination node generally spends less energy compared to the source node, since it is in a receiving mode most of the time, except in responding with short CTS and ACK control frames. In case of IEEE 802.11b irrespective of the distance, approximately 25J of energy i.e. 2.5% of the battery life is used by the destination node in replying to the source with a CTS frame and an ACK control frames. But in case of LBT-NA Cross Layer MAC and LBT-NA with optimized-EIFS MAC, the energy usage by the des-

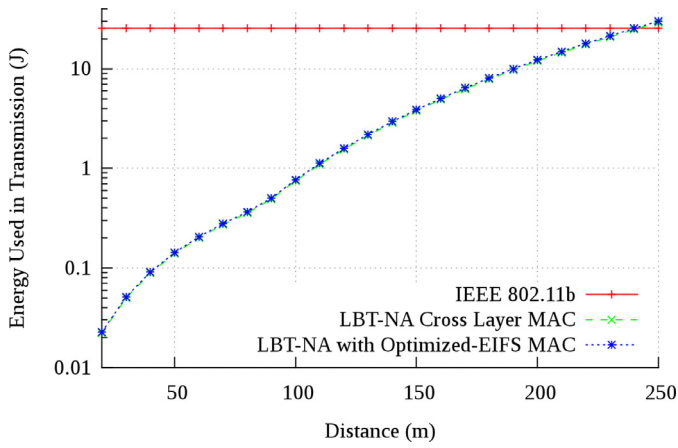

Fig. 8. Energy used by destination while responding with CTS and ACK frames over distance.

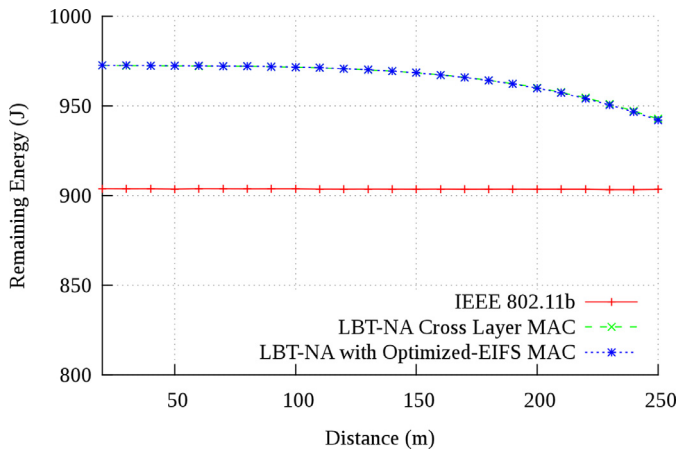

Fig. 9. Total remaining energy of a destination node over distance.

tionation node varies based on the distance of communication between the source and the destination pair. LBT-NA Cross Layer MAC and LBT-NA with optimized-EIFS MAC uses approximately 0.5% and 3.0% of the initial battery life when the distance of communication is less than 150 m and 250 m respectively. When a pair of node communicates using LBT-NA Cross Layer MAC and LBT-NA with optimized-EIFS MAC, it yields 2% increase in an end-to-end performance over IEEE 802.11b, which means that more CTS and ACK frames were generated by the destination, so more energy is used when maximum transmission range of 250 m is used compared to IEEE 802.11b as shown in Fig. 8, but the overall use of energy in the power controlled MAC is less depending on the distance of communication.

In a short distance communication of less than 100 m, energy usage of the destination node using LBT-NA Cross Layer MAC and LBT-NA with optimized-EIFS is less than 3% of the battery life. In case of IEEE 802.11b, the destination node uses approximately 10% of the energy after the destination node is active for 1000 seconds. The Fig. 9 also reflects the total energy spent by the destination node and it includes the total amount of energy spent when it conducts sensing, sending of CTS and ACK, reception of RTS and Data frames, sending/reception of any other frames like routing frames, and energy spent during deferring or backoff. As shown in Fig. 9, the amount of remaining energy reduces as the distance of communication increases and when the distance of communication is 250 m, LBT-NA Cross Layer MAC and LBT-NA with optimized-EIFS MAC uses approximately 6.0% and IEEE 802.11b still uses 10.0% because of the use of a fixed maximum transmission power. When

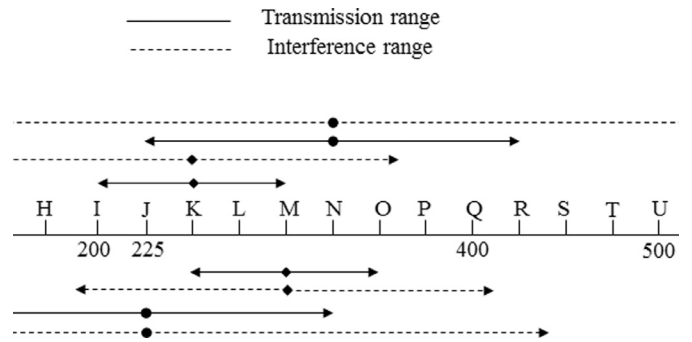

Fig. 10. Partial hidden node issue.

the distance of communication is short (up to 100 m), IEEE 802.11b uses 3.3 times the energy used by LBT-NA Cross Layer MAC and LBT-NA with optimized-EIFS MAC. When the distance of communication is long (250 m), then the IEEE 802.11b uses an additional 4% of energy compared to LBT-NA Cross Layer MAC and LBT-NA with optimized-EIFS MAC.

4.2. Partially hidden node issue

Here, a study is conducted on the importance of dynamically adjusting the power of transmission based on the neighbour's transmission power to maintain the degree of fairness among the contending nodes. In the network topology of Fig. 10, node K sends to node M and node N sends to node J. Moreover, in this network arrangement, $d_{K,M}=50$ m, $d_{N,J}=100$ m, $d_{K,N}=75$ and $d_{J,M}=75$ m. Therefore, when LBT-NA Cross Layer MAC uses a minimum transmission power to cover the Euclidian distance between the communicating nodes, node N and J are not aware of the existence of node K and node M respectively. However, node K and M are both within the transmission range of node N and J. On the other hand, when the transmission power of the neighbour nodes are considered as in LBT-NA with optimized-EIFS MAC, node M increases its transmission power to cover node J and node K also increases its transmission power to reach node N to avoid hidden nodes. Thus, in LBT-NA with optimized-EIFS MAC, node N and J are aware of the activity of node K and M. Finally, in LBT-NA Cross Layer MAC, node K and M communicate with a transmission power to cover only 50 m and node N and node J communicate with a transmission power to cover 100 m. But in case of LBT-NA with optimized-EIFS MAC, node K and node M increase their transmission power to cover a radial distance of 75 m to reach node N and node J respectively, while node N and node J communicate to cover 100 m.

$$J(x_1, x_2, x_3, \dots, x_n) = \frac{(\sum_{i=1}^n x_i)^2}{n \cdot \sum_{i=1}^n x_i^2} \quad (5)$$

The fairness index of the partial hidden node issue of the network topology of Fig. 10 is shown in Fig. 11. As the offered load of the network increases, using LBT-NA Cross Layer MAC, one flow gradually overtakes the other and at around 1500 kb/s, the flow from node K to node M completely captured the channel. The fairness index is measured using (5) the Jain's fairness index [34]. In this method of measuring the fairness index, 50% fairness indicates that one flow has completely captured the channel when there are only two flows. The degree of unfairness beyond 1500 kb/s in LBT-NA Cross Layer MAC is due to two reasons. Firstly, it is due to hidden nodes generated by using only minimum transmission power and secondly, it is due to the use of fixed EIFS ($SIFS_{time} + DIFS_{time} + Tx_Time_{ack}$) for deferring by node N. Node N is within a sensing range of node K, so assuming that the erroneous data frame arriving at node N from source node K as an

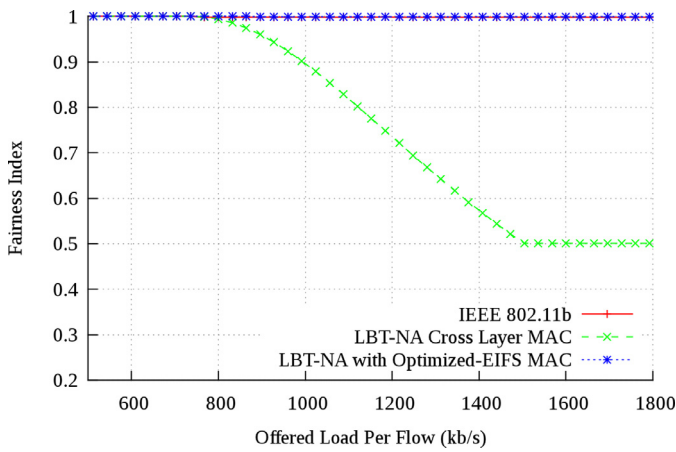

Fig. 11. Fairness index of partial hidden node issue.

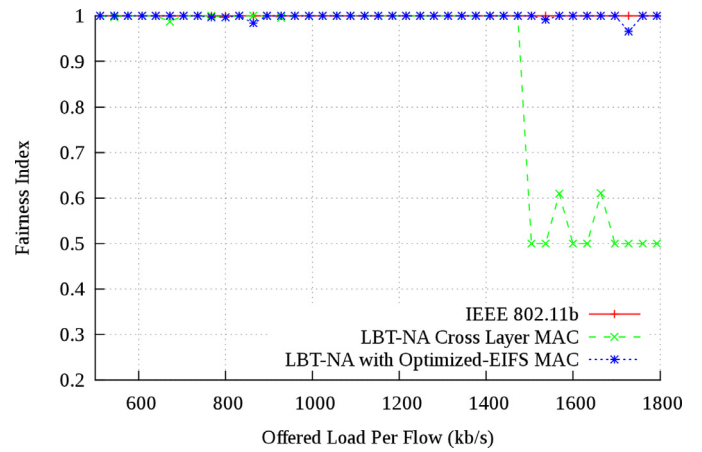

Fig. 13. Fairness index of completely hidden node issue.

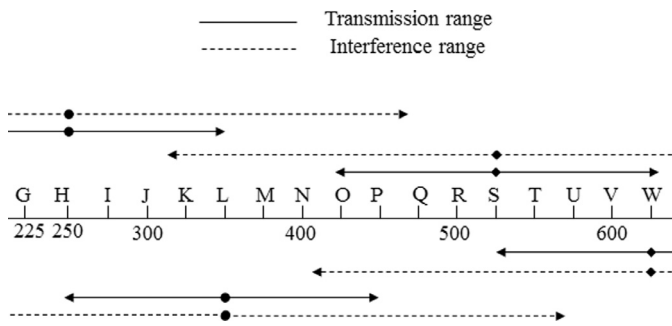

Fig. 12. Completely hidden node issue.

ACK is not true. In this case, node K is a source, so the possible frames generated by node K to node M, are RTS and Data frames and not ACK frame. Thus, the deferring time of node N is wrongly estimated.

In case of LBT-NA with optimized-EIFS MAC, optimal distance of an active neighbours are taken into account while estimating the transmission power with an aim to eliminate the impact of hidden nodes. So, the hidden nodes are made discoverable by increasing the transmission power to ensure fair channel access. Regardless of the offered load in the network, LBT-NA with optimized-EIFS MAC maintains fair access to all the contending flows as shown in Fig. 11. Even when the network gets saturated, the LBT-NA with optimized-EIFS achieved 99.97% fairness compared to 50% fairness in case of LBT-NA Cross Layer MAC. In IEEE 802.11b, the transmission power is fixed with a transmission range of 250 m. So, a fair channel access in this scenario is expected since all the nodes are within the transmission range of each other. Thus, the contending flows achieved a fairness of 99.86% in IEEE 802.11b.

4.3. Completely hidden node issue

In order to investigate the impact and performance of the network when source nodes are completely hidden from one another, a network topology of Fig. 12 is considered. In this topology, pairs of nodes are communicating without the knowledge of another pair, but are within the interference range (sensing range) of each other. In the given topology of Fig. 12, Node L and node S send data to node H and node W respectively. The distance between the sources i.e. node L and node S is separated by 175 m, and the distance between node L and node H is 100 m. Likewise, the distance between the other source node S and its destination node W is also 100 m. So, in such network topology, activity of one affects the other. In this network arrangement, the source node L

and node S are not aware of each other since they both are within a sensing range when power controlled MAC mechanisms based on distances are in operation. Even though node L and S are closer to each other, neither of them will be able to re-adjust the transmission power to avoid the hidden node issue since they are out of the transmission range of each other. Without the knowledge of the node that sends a particular data frame, it is impossible to accurately defer from accessing the channel to avoid collision. When one of the sources is busy, the node within a sensing range intercepts an erroneous frame. When the deferring time of source node L or node S is not accurate, then one node may end up capturing the channel while the other node keeps deferring or the other way round or both sources may hibernate in deferring or collision may occur at all times. In standard IEEE 802.11b, a fixed amount of EIFS is deferred by a node when it senses erroneous data, but the proposed mechanism senses the busy state of the channel and interprets the type of frame based on its length. Thus, the source node L and node S defer accessing the channel with near equal probability by indirectly knowing how long to defer when one of them is engaged with the channel using an optimized EIFS values listed in Tables 5 and 6.

The fairness index of the network performance of the network topology of Fig. 12 is shown in a graph of Fig. 13. The traffic flows of power controlled location based LBT-NA Cross Layer MAC are fair when the per-flow offered load is under 1500 kb/s, but thereafter one flow captured the channel and the other starved. During network saturation, one flow completely overtakes the other, which is due to the fact that the starving node defers channel access for an inaccurate fixed EIFS time. But in case of LBT-NA with optimized-EIFS, the flows are completely fair to a degree of 99.99%, which is due to deferring accurately using an optimized EIFS based on accurately predicting the frame type when a node falls within a sensing range of another node. In the case of IEEE 802.11b, a maximum fixed power transmission is used. So, the source node L and node S are within the transmission range of each other. Hence the contenders have fair channel access.

4.4. Random topology

In order to validate the robustness of the proposed technique and to confirm that the results are not an artefact of artificially arranged networks, a more realistic random topology with a defined space boundary is considered as shown in Fig. 14 and simulated by using the network parameters listed in Table 7. The random topology is tested using different types of traffic like CBR, TCP and Exponential with a frame size of 1000bytes. The node deployment area is divided into five sections of which four sections

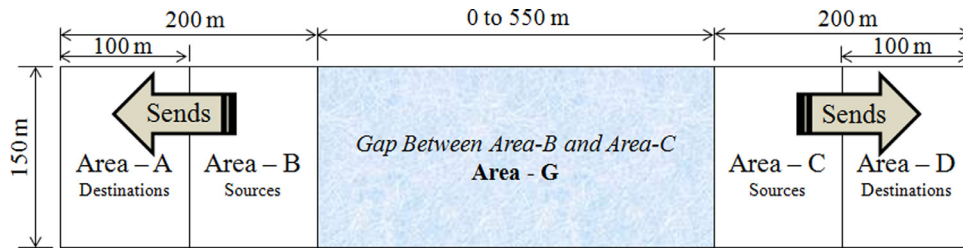

Fig. 14. Random topology with fixed boundaries.

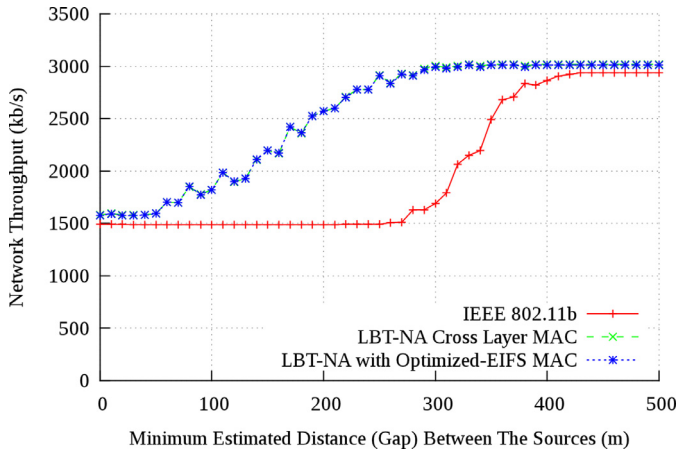

Fig. 15. Network performance of random sources and destinations using CBR traffic.

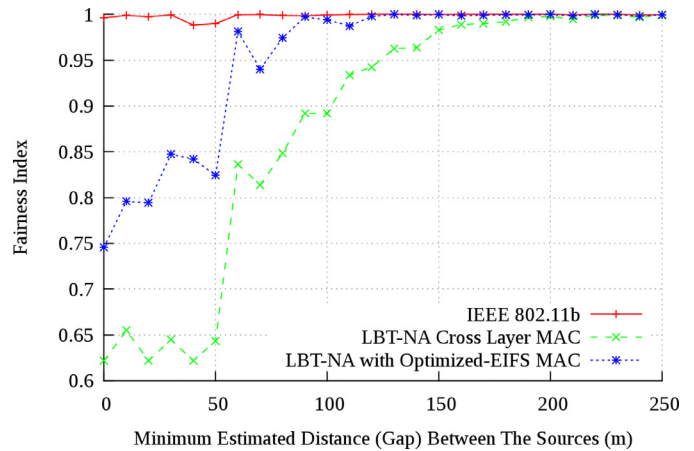

Fig. 16. Fairness index of random sources and destinations using real time traffic (CBR).

(Area-A, Area-B, Area-C and Area-D) are 150 m x 100 m and one special section that separates Area-B and Area-C is Area-G which is 150 m x {0 m;550 m} as presented in Fig. 14. Nodes from Area-B and Area-C are used as source nodes and transmit to destination nodes selected in random from Area-A and Area-D. When the length of the areal gap Area-G is 0 m, hundred rounds of simulations for duration of 1000 s is conducted to measure the performance of the randomly selected source and destination pair and repeat the process by increasing the length of areal gap of Area-G by 10 m, until the length of the areal gap Area-G is 550 m. The per-flow offered load in the network is 2000 kb/s in case of CBR and Exponential traffic. In an Exponential traffic generation, there are two different events called the burst-time and the idle-time. The burst-time is the duration when the data is generated by the source and the idle-time is the duration when the data generator goes silent. In this paper, burst-time and idle-time of 0.5 sec are considered for an Exponential traffic.

4.4.1. Random topology with CBR traffic

The network performance of CBR traffic using the network topology arranged in Fig. 14 is shown in Fig. 15. As the separation distance between the sources increases, the resulting network performance of the proposed protocol LBT-NA with optimized-EIFS MAC and LBT-NA Cross Layer MAC increases rapidly as the sources generate CBR traffic unlike IEEE 802.11b MAC, which uses a fixed maximum transmission range. When the distance between the sources is increased and the transmission power is controlled, then the probability of concurrent transmission of the exposed sources increases rapidly. In the similar scenario, a fixed transmission power mechanism, such as IEEE 802.11b, the probability of parallel transmission in the network is possible only when the length of AREA-G is at least 300 m due to high interference range. During network saturation, location based power controlled MAC such as LBT-NA with optimized-EIFS MAC and LBT-NA Cross Layer MAC gains an additional 80 kb/s i.e. approximately 3.0% throughput

over a fixed maximum transmission power like IEEE802.11b. Even when the sources are separated with a small distance, there is at least a performance gain of approximately 3.0% in the proposed power controlled MAC over IEEE 802.11b. The additional performance gain in the proposed power controlled MAC is due to use of backoff values based on the degree of contention.

Due to location based transmission, in LBT-NA with optimized-EIFS MAC and LBT-NA Cross Layer MAC the probability of concurrent transmission is fully achieved when the length of the areal Area-G is 300 m and above, unlike IEEE 802.11b, where parallel transmission is fully achieved only after the length of the areal gap of Area-G is at least 400 m. In Fig. 15, when the length of areal gap of Area-G is 200 m, the performance gain of location based power controlled MAC, LBT-NA with optimized-EIFS and LBT-NA Cross Layer is approximately 70% over an IEEE 802.11b MAC, due to use of low transmission power based on the location of the nodes. Thus, the probability of parallel transmission is directly proportional to the length of areal gap Area-G which defines the distance between the sources. Therefore, using a location based power controlled MAC enhances the overall network performance over a fixed transmission power method like IEEE 802.11b.

The fairness index of the CBR traffic for the random topology scenario of Fig. 14 is shown in Fig. 16. The fairness index of the traffic flows, generated using random sources from Area-B and Area-C, shows that LBT-NA with optimized-EIFS outperforms the minimum power based MAC like LBT-NA Cross Layer MAC. The disadvantage of a power controlled mechanism is that the probability of a node being hidden is higher due to varying transmission ranges. Due to the use of high fixed transmission power, IEEE 802.11b is fairer in accessing the shared channel but performance is low when the sources are closer unlike power controlled transmission. The degree of fairness of the traffic flow increases in LBT-NA Cross Layer MAC as well as LBT-NA with optimized-EIFS MAC as the length of Area-G increases. However, when the sources are

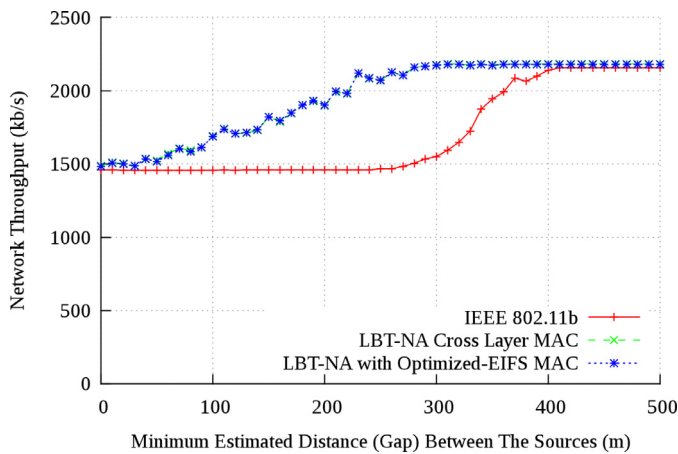

Fig. 17. Network performance of random sources and destinations using Exponential traffic.

closer, the degree of fairness of LBT-NA with an optimized-EIFS is at least 13% compared to LBT-NA Cross Layer MAC. The traffic flows are fairer in LBT-NA with optimized-EIFS MAC because an active node increases its transmission power when neighbour's transmission power is higher to avoid hidden node issue and moreover, when an active node is within a sensing range of another node, then it defers accurately based on the duration of busy state of the channel by interpreting the type of frames by using an optimized EIFS. Thus, LBT-NA with optimized-EIFS MAC attends a fairness of 95.0% only when the length of the areal gap Area-G is only 50 m, unlike LBT-NA Cross Layer MAC which struggles to attend the same degree of fairness only when the length of the areal gap Area-G is approximately 125 m.

4.4.2. Random topology with Exponential traffic

The network topology from Fig. 14 is considered for evaluating the Exponential traffic as well. In terms of overall network performance, CBR traffic gains higher throughput since data is generated at a constant rate, unlike Exponential traffic where the source generate traffic during burst-time and goes silent during idle-time. When traffic flow exhibit concurrent transmission with a per flow data rate of 2000 kb/s, the overall network gain using CBR traffic is approximately 27.0% over Exponential traffic. When the channel is shared (sources are close to each other) or during parallel communication (sources are out of the interference range of each other), the power controlled MAC experience a performance gain of approximately 2% over IEEE 802.11b. This gain is due to the use of dynamic backoff values based on the number of active neighbours instead of using a fixed large contention window as in IEEE 802.11b. As shown in Fig. 17, the network performance increases in power controlled MAC, irrespective of the traffic types due to exhibiting higher rate of parallel communication. When the minimum separation distance between the sources is 200 m, there is an overall network performance gain of approximately 30% in case of LBT-NA Cross Layer MAC and LBT-NA with optimized-EIFS MAC over IEEE 802.11b due to power control transmission.

The fairness index of the Exponential traffic using the random topology arrangement of Fig. 14 is shown in Fig. 18. The degree of fairness among the flows of the location based power control MAC of LBT-NA Cross Layer MAC and LBT-NA with optimized-EIFS MAC are similar, with a slight advantage for LBT-NA with optimized-EIFS MAC over LBT-NA Cross Layer MAC. The lowest fairness index value of LBT-NA Cross Layer MAC is approximately 96% and that of LBT-NA with optimized-EIFS MAC is approximately 98%. Since the transmission power of IEEE 802.11b is high and fixed, the degree of fairness among the contending sources are fairer in this

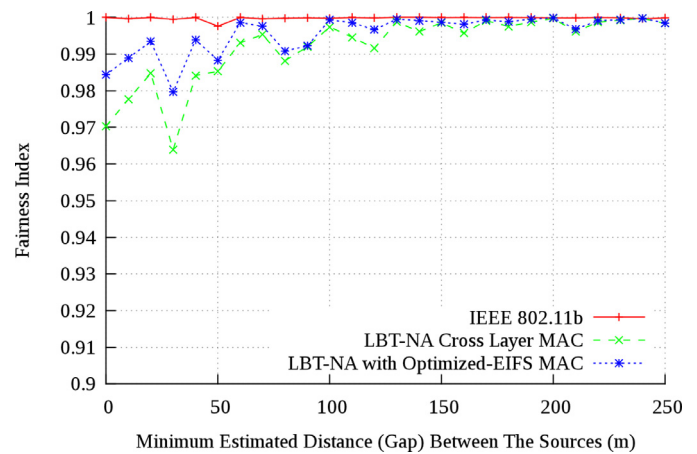

Fig. 18. Fairness index of random sources and destinations using Exponential traffic.

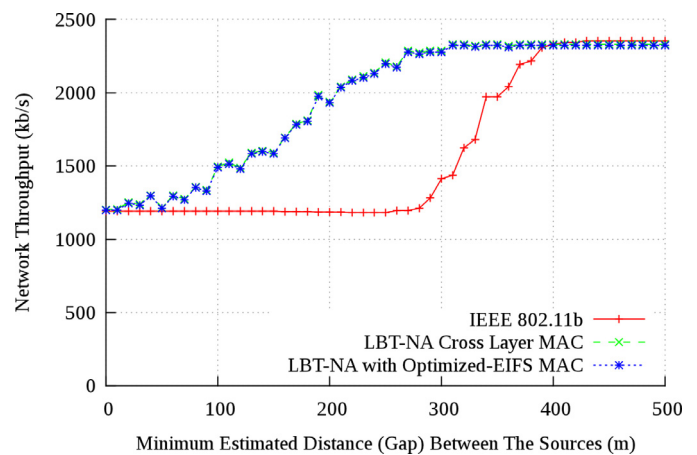

Fig. 19. Network performance of random sources and destinations using TCP traffic.

case as well. Among the power controlled mechanisms, in terms of fairness, CBR traffic outperforms Exponential traffic in LBT-NA with optimized-EIFS over LBT-NA Cross Layer MAC.

4.4.3. Random topology with TCP traffic

The performance of TCP is also tested with the random topology of Fig. 14 and the result is presented in Fig. 19. Similar to CBR and Exponential traffic, the performance of TCP also increases as the distance between the sources increases. The increase in the performance of the power controlled transmission is due to the increase in the probability of concurrent transmission as explained earlier. When the length of Area-G is 200 m, the network performance gain in the location based power control LBT-NA Cross Layer and LBT-NA with optimized-EIFS MAC is approximately 63% over the fixed maximum transmission power MAC like IEEE 802.11b. In a fixed power transmission like IEEE 802.11b, the sources of Area-B and Area-C could exhibit parallel communication only when the length of the areal gap Area-G is at least 300 m.

In the saturated region, the TCP traffic running with IEEE802.11b performs slightly better with a network performance gain of 20 kb/s i.e. approximately 1.0% to that of the location based transmission power control LBT-NA Cross Layer MAC and LBT-NA with optimized-EIFS MAC. The performance is slightly decreased in an access mechanism using small initial backoff values because the probability of collision is higher and if a frame gets lost then

the window size is reduced in TCP which results in a performance degradation.

The TCP traffic flows of the random topology network of Fig. 14 are relatively fair in both the fixed transmission power like IEEE 802.11b and power controlled MAC like LBT-NA Cross Layer MAC and LBT-NA with optimized-EIFS MAC. It is due to the fact that in TCP, frames are sent based on the congestion window. The lowest degree of fairness of the traffic flows in the network using LBT-NA Cross Layer MAC, LBT-NA with optimized-EIFS MAC, and IEEE 802.11b MAC are 96%, 98% and 97.5% respectively. Moreover, unlike CBR and Exponential traffic, the degree of fairness among the traffic flows using TCP are fairer in both the power controlled MAC as well as the fixed transmission power MAC like the standard IEEE 802.11b.

5. Conclusion and future direction

This paper proposed a new MAC called LBT-NA with optimized-EIFS, which controls transmission power based on the location and the optimal distance of the active one hop neighbour. This cross-layer protocol uses a dynamic EIFS based on the type of the frame when frame error occurs mainly due to reception within an interference range of other active nodes or when a frame with a stronger signal is captured. Unlike LBT-NA cross-layer MAC, which uses a minimum power transmission based on the location of the communicating node, LBT-NA with optimized-EIFS MAC adjusts the transmission power based on neighbour's activity to avoid hidden node issues. In a power controlled transmission, due to varying transmission ranges, it is impossible to avoid all hidden node issues. However, for further avoidance of hidden node issues even when a node is within interference or sensing range, an accurate deferring mechanism is proposed where activity of the interfering node is predicted based on the duration of the busy state of the channel and defers accordingly using an optimized EIFS. Thus, by using an optimized EIFS and adjusting the transmission power based on neighbour's activity, hidden node issues are reduced or removed and the gain in the degree of fairness over a method using a minimum transmission power is up to 50% depending on the topology and traffic types. Moreover, using a backoff value based on the number of active neighbourhood helps active nodes in saving energy when contention is low and increases the network performance too. Due to the power controlled mechanism, the performance of the network in terms of utilization and reuse of bandwidth increases in comparison with the standard IEEE 802.11b. In a random topology with a random source and destination with two sources which are separated by a minimum distance of 200 m, the performance gain of power controlled MAC over IEEE 802.11b ranges from 30% to 70% depending on the type of traffic in the network. Thus, overall LBT-NA with optimized-EIFS MAC is better than the power controlled LBT-NA Cross Layer MAC, which uses a minimum power transmission and fixed transmission power like IEEE 802.11b in terms of fairness, performance and energy utilization.

Future work will focus on effectively measuring the received signal strength at the receiver in order to estimate the distance between the source and the destination rather than using location information and propose a solution to reduce the ripple effect of increasing the transmission power of neighbours when an active node increases its transmission power due to the activity of other neighbours. The future works also aim in reducing hidden node issues at a higher scale especially when node mobility and power controlled transmission are both taken into account. The authors also aim to test the performance of the proposed mechanism in a real environment and compare the results with the simulation work.

Acknowledgements

The authors would link to thank the Centre of Security, Communications and Network (CSCAN) Research Laboratory of Plymouth University and Computing Department of Sheffield Hallam University for providing the platform to conduct the research work. We are grateful for all the helpful comments received from multiple reviewers in improving the paper. Last but not the least; the authors would also like to thank Mr. Gregg Ibbotson for proofreading the manuscript during the revision process.

References

- [1] J. Marchang, B. Ghita, D. Lancaster, Hop-based dynamic fair scheduler for wireless Ad-Hoc networks, in: *Advanced Networks and Telecommunications Systems (ANTS)*, 2013 IEEE International Conference on 15–18, Dec, 2013, pp. 1–6, doi:10.1109/ANTS.2013.6802873.
- [2] V.G. Douros, G.C. Polyzos, Review: review of some fundamental approaches for power control in wireless networks, *Comput. Commun. ACM Digital Lib.* 34 (13) (2011) 1580–1592 (August 2011), doi:10.1016/j.comcom.2011.03.001.
- [3] N.L. Pradhan, T. Saadawi, Power control algorithms for mobile ad hoc networks, *J. Adv. Res. Sci. Direct on 2* (3 (July)) (2011) 199–206 ISSN 2090-1232, doi:10.1016/j.jare.2011.04.009.
- [4] L.M. Patnaik, S. Hasan Raza Naqvi, A review of medium access protocols for mobile ad hoc networks with transmission power control, *Microprocess. Microsyst.* 28 (8) (4 October 2004) 447–455. ISSN 0141-9331 <http://dx.doi.org/10.1016/j.micpro.2004.03.021>.
- [5] Z. Zhao, X. Zhang, P. Sun, P. Liu, A transmission power control MAC protocol for wireless sensor networks, *Networking, 2007. ICN '07. Sixth International Conference on*, 22–28 April, 2007 5–5, doi:10.1109/ICN.2007.12.
- [6] K. Kosek-Szot, A survey of MAC layer solutions to the hidden node problem in ad-hoc networks, *Ad Hoc Netw.* 10 (3 (May)) (2012) 635–660. ISSN 1570-8705 <http://dx.doi.org/10.1016/j.adhoc.2011.10.003>.
- [7] Z. Li, S. Nandi, A.K. Gupta, ECS: an enhanced carrier sensing mechanism for wireless ad hoc networks, *Comput. Commun.* 28 (17) (17 October 2005) 1970–1984. ISSN 0140-3664 <http://dx.doi.org/10.1016/j.comcom.2005.04.001>.
- [8] Alaa, M.; M. Krunk, "A single-channel solution for transmission power control in wireless ad hoc networks", In *Proceedings of the 5th ACM International Symposium on Mobile Ad Hoc Networking and Computing (MobiHoc 2004)*. ACM, New York, NY, USA, pp.210–221, doi:10.1145/989459.989486.
- [9] A. Muqattash, M. Krunk, POWMAC: a single-channel power-control protocol for throughput enhancement in wireless ad hoc networks, *Sel. Areas Commun. IEEE J.* 23 (5) (May 2005) 1067–1084, doi:10.1109/JSAC.2005.845422.
- [10] P. Li, X. Geng, Y. Fang, An adaptive power controlled MAC protocol for wireless ad hoc networks, *Wireless Commun. IEEE Trans.* 8 (1) (Jan. 2009) 226–233, doi:10.1109/T-WC.2009.070993.
- [11] D. Kim, E. Shim, C.K. Toh, A power control MAC protocol based on fragmentation for 802.11 multi-hop networks, in: *Information Networking. Advances in Data Communications and Wireless Networks Lecture Notes in Computer Science*, 3961, 2006, pp. 227–236.
- [12] Y. Li, A. Ephremides, A joint scheduling, power control, and routing algorithm for ad hoc wireless networks, *Ad Hoc Netw.* 5 (7) (September 2007) 959–973 ISSN 1570-8705, doi:10.1016/j.adhoc.2006.04.005.
- [13] W. Wang, V. Srinivasan, K.C. Chua, Power control for distributed MAC protocols in wireless ad hoc networks, *Mobile Comput. IEEE Trans.* 7 (10) (Oct. 2008) 1169–1183, doi:10.1109/TMC.2008.40.
- [14] D.D. Seth, S. Patnaik, S. Pal, EPCM – an efficient power controlled MAC protocol for mobile ad hoc network, *Int. J. Electron.* 101 (10) (2014) 1443–1457 Taylor & Francis Online on, doi:10.1080/00207217.2013.858301.
- [15] K.P. Shih, Y.D. Chen, CAPC: a collision avoidance power control MAC protocol for wireless ad hoc networks, *Commun. Lett. IEEE* 9 (9) (September 2005) 859–861, doi:10.1109/LCOMM.2005.1506727.
- [16] E.S. Jung, N.H. Vaidya, A power control MAC protocol for ad hoc networks, *Wireless Netw.* 11 (1–2) (January 2005) 55–66 Springer, doi:10.1007/s11276-004-4746-9.
- [17] E.A. Varvarigos, G. Vasileios, K. Nikolaos, The slow start power controlled MAC protocol for mobile ad hoc networks and its performance analysis, *Ad Hoc Netw.* 7 (6) (August 2009) 1136–1149 Science Direct ISSN 1570-8705, doi:10.1016/j.adhoc.2008.10.001.
- [18] M. Cui, V.R. Syrotiuk, Time-space backoff for fair node throughput in wireless networks using power control, *Ad Hoc Netw. ACM Digital Lib.* 8 (7) (September 2010) 767–777, doi:10.1016/j.adhoc.2010.02.007.
- [19] Y. Chen, E.G. Sire, S.B. Wicker, On selection of optimal transmission power for ad hoc networks, in: *System Sciences, 2003. Proceedings of the 36th Annual Hawaii International Conference on*, Jan. 2003, doi:10.1109/HICSS.2003.1174848.
- [20] M. Di Francesco, G. Anastasi, M. Conti, S.K. Das, V. Neri, Reliability and energy-efficiency in IEEE 802.15. 4/ZigBee sensor networks: an adaptive and cross-layer approach, *IEEE J. Sel. Areas Commun.* 29 (8) (2011) 1508–1524.
- [21] J. He; J. Yang; C. An; X. Li, "Transmission power selection for ad hoc networks", In *Proceedings of the 4th Annual International Conference on Wireless Internet (WICON 2008)*. ICST (Institute for Computer Sciences, Social-Informatics

- and Telecommunications Engineering), ICST, Brussels, Belgium, Belgium, Article 18, 9 pages, ISBN: 978-963-9799-36-3.
- [22] D.N.M. Dang, C.S. Hong, S. Lee, J. Lee, A sinr-based mac protocol for wireless ad hoc networks, *IEEE Commun. Lett.* 16 (12) (2012) 2016–2019.
- [23] D.B. Rawat, D.C. Popescu, G. Yan, S. Olariu, Enhancing VANET performance by joint adaptation of transmission power and contention window size, *IEEE Trans. Parallel Distrib. Syst.* 22 (9) (2011) 1528–1535.
- [24] K.P. Shih, Y.D. Chen, C.C. Chang, A physical/virtual carrier-sense-based power control MAC protocol for collision avoidance in wireless ad hoc networks, *IEEE Trans. Parallel Distrib. Syst.* 22 (2) (2011) 193–207.
- [25] J. Liu, X. Jiang, H. Nishiyama, N. Kato, Exact throughput capacity under power control in mobile ad hoc networks, in: *INFOCOM, 2012 Proceedings IEEE*, IEEE, 2012, March, pp. 1–9.
- [26] X.M. Zhang, Y. Zhang, F. Yan, A.V. Vasilakos, Interference-based topology control algorithm for delay-constrained mobile ad hoc networks, *IEEE Trans. Mobile Comput.* 14 (4) (2015) 742–754.
- [27] J. Marchang, B. Ghita, D. Lancaster, Location based transmission using a neighbour aware-cross layer MAC for ad hoc networks, in: *International Conference on Wired/Wireless Internet Communication*, Springer International Publishing, 2016, pp. 15–27.
- [28] D. Kotz, C. Newport, R.S. Gray, J. Liu, Y. Yuan, C. Elliott, Experimental evaluation of wireless simulation assumptions, in: *Proceedings of the 7th ACM international symposium on Modeling, analysis and simulation of wireless and mobile systems*, ACM, 2004, October, pp. 78–82.
- [29] T.S. Rappaport, *Wireless Communications: Principles and Practice*, 2nd ed., Pearson Education, Inc., Singapore, 2002.
- [30] S. Haykin, M. Moher, *Modern Wireless Communications*, Pearson Education, Inc., Singapore, 2002.
- [31] J.W. Mark, W. Zhuang, *Wireless Communications and Networking*, PHI, New Delhi, 2005.
- [32] C. Sommer, F. Dressler, Using the right Two-Ray Model? A measurement based evaluation of PHY models in VANETs, in: *Proceedings of 17th ACM International Conference on Mobile Computing and Networking (MobiCom 2011)*, Las Vegas, NV, Poster Session, September 2011.
- [33] IEEE wireless LAN medium access control (MAC) and physical layer (PHY) specifications, IEEE 802.11 standards (1999).
- [34] D. Chiu, R. Jain, Analysis of the increase/decrease algorithms for congestion avoidance in computer networks, *J. Comput. Netw. ISDN* 17 (1) (June 1989) 1–14.



Dr. Jims Marchang received his PhD in 2016 from Plymouth University, UK. He is a lecturer at Sheffield Hallam University. He is a recipient of the Best Paper award of Advanced Computing and Communications (ADCOM) International Conference, 2007 and a member of IEEE Computer Society. His main research topic includes QoS in Ad-Hoc Networks, Internet of Things, Cloud Computing, Big Data and Information Security.



Dr Bogdan Ghita received his PhD in 2005 from Plymouth University, UK. He is associate professor at Plymouth University and leads the networking area within the Centre for Security, Communications, and Network Research. His research interests include computer networking and security, focusing on the areas of network performance modelling and optimisation, wireless and mobile networking, and security. He has been principal investigator in a number of industry-led, national, and EU research projects. He was a TPC member for over 40 international conference events as well as a reviewer for IEEE communications letters, computer communications, and future generation computer systems journals and he is the chair of the International Networking Conference series.



Dr David Lancaster is a lecturer at Plymouth University. He received his PhD in Physics in 1984, but has been working on various computing topics for the past 15 years.