



Hu, Yukun and Wang, Jihong and Tan, C.K. and Sun, Chenggong and Liu, Hao (2017) Further improvement of fluidized bed models by incorporating zone method with Aspen Plus interface. *Energy Procedia*, 105 . pp. 1895-1901. ISSN 1876-6102

Access from the University of Nottingham repository:

<http://eprints.nottingham.ac.uk/43445/1/YukunHu-EnergyProcediaPaper2017.pdf>

Copyright and reuse:

The Nottingham ePrints service makes this work by researchers of the University of Nottingham available open access under the following conditions.

This article is made available under the Creative Commons Attribution Non-commercial No Derivatives licence and may be reused according to the conditions of the licence. For more details see: <http://creativecommons.org/licenses/by-nc-nd/2.5/>

A note on versions:

The version presented here may differ from the published version or from the version of record. If you wish to cite this item you are advised to consult the publisher's version. Please see the repository url above for details on accessing the published version and note that access may require a subscription.

For more information, please contact eprints@nottingham.ac.uk

The 8th International Conference on Applied Energy – ICAE2016

Further improvement of fluidized bed models by incorporating zone method with Aspen Plus interface

Yukun Hu^{a,*}, Jihong Wang^a, CK Tan^b, Chengong Sun^c, Hao Liu^c

^a*School of Engineering, University of Warwick, Coventry CV4 7AL, UK*

^b*Faculty of Computing, Engineering and Science, University of South Wales, Pontypridd CF37 1DL, UK*

^c*Faculty of Engineering, University of Nottingham, Nottingham NG7 2RD, UK*

Abstract

While providing a fast and accurate tool of simulating fluidized beds, the major limitation of classical zero-dimensional ideal reactor models used in process simulators, such as models built into commercial software (e.g. Aspen Plus[®]), has been the difficulties of involving thermal reciprocity between each reactor model and incorporating heat absorption by the water wall and super-heaters which is usually specified as model inputs rather than predicted by the models themselves. This aspect is of particular importance to the geometry design and evaluation of operating conditions and flexibility of fluidized beds. This paper proposes a novel modelling approach to resolve this limitation by incorporating an external model that marries the advantages of zone method and Aspen Plus in a robust manner. The improved model has a relatively modest computing demand and hence may be incorporated feasibly into dynamic simulations of a whole power plant.

© 2017 The Authors. Published by Elsevier Ltd. This is an open access article under the CC BY-NC-ND license (<http://creativecommons.org/licenses/by-nc-nd/4.0/>).

Peer-review under responsibility of the scientific committee of the 8th International Conference on Applied Energy.

Keywords: zone method; Aspen Plus; fluidized beds; process simulation; radiation analysis

1. Introduction

Circulating Fluidized Bed (CFB) technology has been developed and served as effective method for burning solid fuels for many industrial applications since the 1980s, such as coal combustion, due to its inherent advantages over conventional combustion method like fuel flexibility, high combustion intensity, and low emissions [1]. Although technical knowledge about the design and operation of CFB is widely available for pilot plant and large scale units [2], few have conducted modelling of the whole CFB power plant and hence little is known about its dynamic performance and operational flexibility [3]. This might be due to the fact that the combustion process occurring in a CFB boiler involves complex phenomena like

* Corresponding author. Tel.: +44 (0)24 765 22333; E-mail address: y.hu.9@warwick.ac.uk (Y. Hu)

chemical reactions, heat and mass transfer, particle reduction due to combustion and it may also lie in the shortage of effective modelling approaches.

Nomenclature

Abbreviations

ABFBC	Atmospheric Bubbling Fluidized-Bed Combustor
CFB	Circulating Fluidized Bed
CPFD	Computational Particle Fluid Dynamics
DFAs	Directed Flux Areas
MCRT	Monte-Carlo based Ray-Tracing
TEAs	Total Exchange Areas

Symbols

A_i	area of the i-th surface zone	m^2
$\overline{G_1 G_j}, \overline{G_1 S_j}, \overline{S_1 G_j}, \overline{S_1 S_j}$	directed flux areas	m^2
K_i	extinction coefficient of gas zone i	m^{-1}
\dot{m}	mass flow rate	$kg\ s^{-1}$
$\dot{Q}_{conv,i}$	heat convection term of surface zone i	$W\ m^{-2}$
$\dot{Q}_{conv,i}$	heat convection term of gas zone i	W
$\dot{Q}_{enth,i}$	enthalpy transport term of gas zone i	W
$\dot{Q}_{s,i}$	net radiation from the surface zone i	W
$\dot{Q}_{g,i}$	net radiation absorbed by the gas zone i	W
$T_{g,i\ or\ j}$	temperature of gas zone i or j	K
$T_{s,\ i\ or\ j}$	temperature of surface zone i or j	K
V_i	volume of gas zone i	m^3
σ	Stefan-Boltzmann constant (5.6687×10^{-8})	$W\ m^{-2}\ K^{-4}$

CFB modelling has been implemented using commercial software for a long time, such as Aspen Plus[®] [4-7] and Computational Particle Fluid Dynamics (CPFD)[®] [8-9]. Although the advancement in Aspen Plus has made time-dependent dynamic simulation, prediction and control of CFB combustion processes in real time possible, the major limitation is that classical zero-dimensional ideal reactor models used in Aspen Plus has been the difficulties of involving thermal reciprocity between each reactor model and incorporating heat absorption by the water wall and super-heaters which is usually specified as model inputs rather than predicted by the models themselves. This aspect is of particular importance to the geometry design and the evaluation of operating conditions and flexibility of fluidized beds. On the other hand, although CPFD is widely used to simulate combustion systems and can predict the detailed local heat and mass transfer information available for the entire computational domain, it often takes several days if not weeks to provide useful results for large industrial cases. Therefore, CPFD models are unlikely for being incorporated into dynamic simulations and used to study the starting up and shutting down a plant, changes of conditions during a reaction, holdups, thermal changes and more.

In fluidized beds, the combustion efficiency depends on the heat recovered in the freeboard region, where the dominant component of heat transfer is radiation [10]. Therefore, the modelling of the radiative heat transfer in such systems necessitates an accurate knowledge of the radiative analysis. This paper aims to frame a modelling approach that can compromise the above limitations existing in CFB modelling, but not limited to CFB modelling, and involve radiative analysis by incorporating an external model that marries the advantages of zone method [11] and Aspen Plus simulation in a robust manner. The improved model is

expected to have a relatively modest computing demand and hence feasible to be incorporated into dynamic simulations of a whole CFB power plant.

2. Modelling object

A 0.3MW Atmospheric Bubbling Fluidized-Bed Combustor (ABFBC) test rig is used as the simulation object in this work, as shown in Figure 1 [12]. The main body of the test rig is the modular combustor formed by five modules of internal cross section of 0.45×0.45 m and 1 m height. The inner walls of the modules are refractory lined and insulated. The first and fifth modules refer to the bed and cooler, respectively, and the ones between them are the freeboard modules. There exist two cooling surfaces in the modular combustor, as shown in Figure 1, providing 0.35 m^2 and 4.3 m^2 of cooling surfaces, respectively.

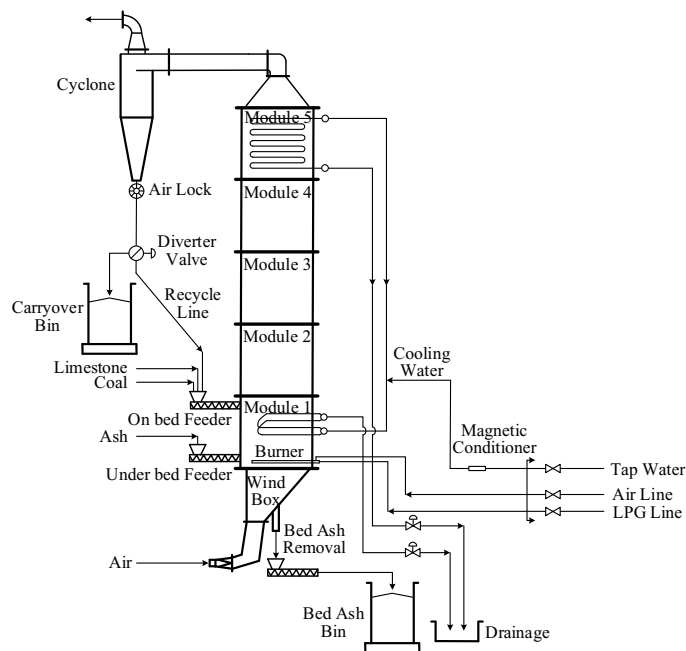

Fig. 1. Schematic of the 0.3 MW ABFBC test rig

3. Modelling approaches

The previous work of *Sotudeh-Gharehaagh et al.* [4] had described in details the implementation of Aspen Plus reactor modules [13] for CFB modelling and hence need not to be repeated here. This paper mainly focuses on the further improvement of the fluidized bed models within the framework of Aspen Plus by incorporating a rigorous radiation sub-model based on the zone method of radiation analysis.

According to the zone method, the relatively simply geometry of the ABFBC is split into a finite number of isothermal volume and surface zones along the height of the freeboard region, as shown in Figure 2. The bottom and the top surfaces including cooling tubes are approximated by equivalent black and gray surface respectively, for modelling purpose. The assumption of plug flow is applied to the flow pattern, and this is reasonable since the flow pattern-led enthalpy transport is dominated in the longitudinal direction of the

fluidized bed. However, even more complicated zoning arrangement and flow pattern are also possible, see [14], which depend on the requirements of a specific problem. An energy balance is formulated for each zone taking into account radiation interchange between all volume and surface zones, the enthalpy transport, and the source term associated with convection [15]. Figure 3 shows the zone model incorporated Aspen Plus flow sheet for ABFBC modelling. RYield (Aspen Plus reactor) is used to model the devolatilization process by specifying the yield distribution vector via an In-Line Fortran Calculator 1 (Aspen Plus calculator block) according to the coal ultimate analysis; RStoic (Aspen Plus reactor) is used to model volatile combustion process by specifying the fractional conversion of key components via an In-Line Fortran Calculator 2; the mean axial voidage in a certain interval between different heights of the combustor is calculated via an In-Line Fortran Calculator 3; char combustion above bed is implemented using a set of RCSTRs (1 to 6 in this case, Aspen Plus reactor) with the user defined kinetics – USRKIN.f (Aspen Plus Subroutine). In the simulation, the RCSTR block temperatures are recalculated by the zone model based on the retrieved enthalpy flows at each iteration to get a new value as the initial value at the next iteration until the convergent tolerance is satisfied.

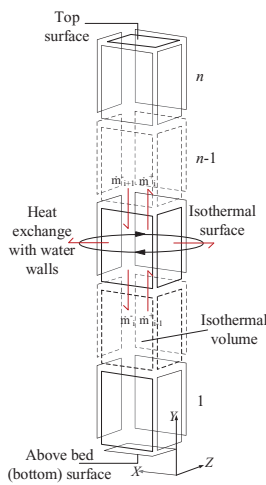

Figure 2 Illustration of zone method applied in the freeboard region of ABFBC

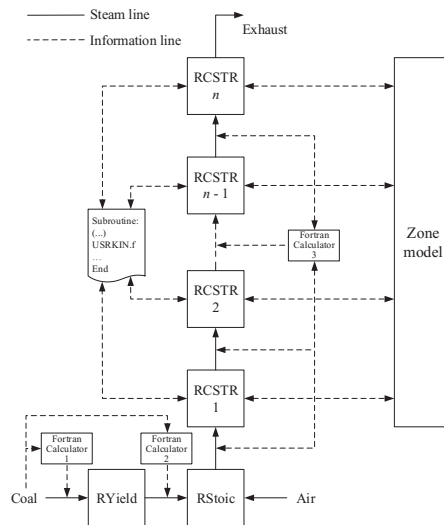

Figure 3 Zone model incorporated Aspen Plus flow sheet for ABFBC modelling

The radiation term in the energy balance equations is written in terms of exchange factors known as Directed Flux Areas (DFAs) (denoted by $\overline{G_i G_j}$, $\overline{G_i S_j}$, $\overline{S_i G_j}$, $\overline{S_i S_j}$ for gas-gas, gas-surface, surface-gas, and surface-surface exchange respectively in Eqs. 1 and 2). The energy balances on all zones yield a set of simultaneous non-linear equations which can be solved to determine the temperature and heat flux at each zone.

For a system of N volume zones and M surface zones, the following energy balances can be written.

$$\dot{Q}_{g,i} = \sum_{j=1}^N \overline{G_i G_j} \sigma T_{g,j}^4 + \sum_{j=1}^M \overline{G_i S_j} \sigma T_{s,j}^4 - 4K_i V_i \sigma T_{g,i}^4 - \dot{Q}_{conv,i} + \dot{Q}_{enth,i}, \tag{Eq. 1}$$

$$\dot{Q}_{s,i} = \sum_{j=1}^M \overline{S_i S_j} \sigma T_j^4 + \sum_{j=1}^N \overline{S_i G_j} \sigma T_{g,j}^4 - A_i \epsilon_i \sigma T_i^4 + A_i \dot{q}_{conv,i}. \tag{Eq. 2}$$

For the i -th volume (gas) zone, $\dot{Q}_{g,i}$ represents the net rate of heat transfer to the volume (gas) zone; likewise, for the i -th surface zone, $\dot{Q}_{s,i}$ represents the net rate of heat transfer to the surface zone.

The DFAs in Eq. 1 – Eq. 2 are the function of Total Exchange Areas (TEAs). The TEAs in this study are calculated using an updated Monte-Carlo based Ray-Tracing (MCRT) algorithm [16] which is also capable of taking into account the individual obstacle geometry inside the computational domain of even more complicated applications. The radiative properties of the particle laden combustion gases are assumed to be uniform and constant throughout the freeboard region. Adiabatic condition is applied to the wall surfaces along the freeboard region, and $\dot{Q}_{s,i}$ therefore equals to zero in this case. The detailed boundary conditions and operating conditions are given in [17]. These data, together with retrieved enthalpy flow data in Figure 3, provide the input data that needs to be supplied to the zone model.

From a given boundary condition these $M+N$ non-linear equations can be solved using the Newton-Raphson method [18]. This method provides an approach of computing successive approximations to the variables which converge towards the solution.

4. Results and discussion

The ABFBC during a steady state operation [17] was simulated in this work. The calculation took 0.67 second to get a converged solution after 8 iterations, and the maximum temperature difference between the values calculated by RCSTR blocks and zone model was less than 10^{-4} K. The measured and predicted thermal behaviours, including gas temperature profile and incident radiative heat fluxes, are shown in Figures 4 and 5, respectively. The gas temperature profiles are found to be in good agreement, but appreciable discrepancies are found in incident radiative heat fluxes at the locations close to the bed and the cooler. Further sensitivity study on the emissivity of the top and bottom surfaces showed that the discrepancies were not mainly attributed to the emissivity values specified to the equivalent surfaces. This might be due to the equivalent surfaces which do not really exist and the radiometer probes located at those heights are also affected by the cooling tubes. In addition, since the inner walls of the freeboard are refractory lined and insulated, heat losses are negligible. The wall temperatures of the freeboard are close to the adjacent gas temperatures during the steady state operation.

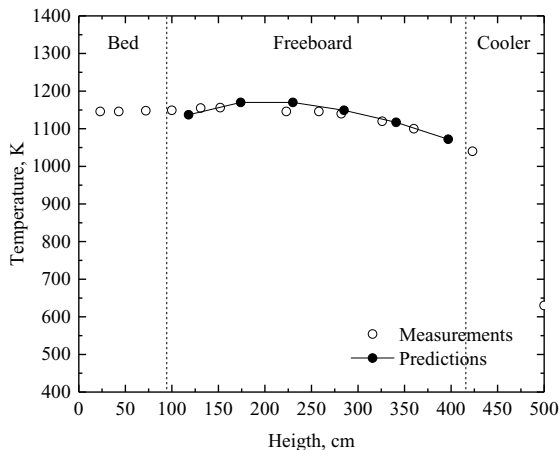

Figure 4 Measured and predicted gas temperature profiles along the height of combustor

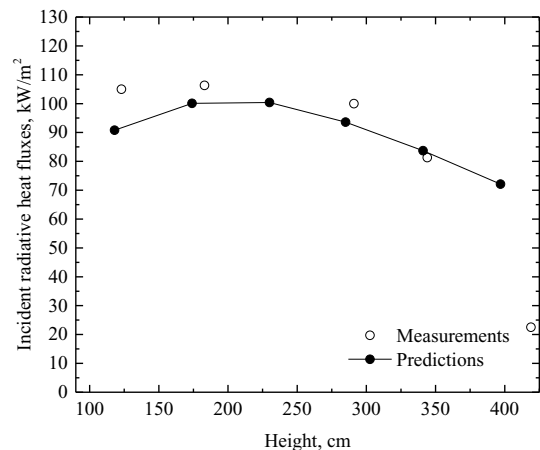

Figure 5 Measured and predicted incident radiative heat fluxes on freeboard side walls

The results above demonstrated that the improved fluidized bed model has a relatively modest computing demand so that it may be incorporated into dynamic simulations of a whole power plant. The implication of current work highlighted the existing limitation of sequential modular strategy in Aspen Plus, in that there is no thermal reciprocity within its modelling framework. By incorporating zone method with Aspen Plus interface in this work, the energy balance takes into account of radiation interchange between all volume and surface zones, the enthalpy transport, and the source term associated with convection. Although the improved model is one-dimensional in this case, the proposed modelling approach is equally applicable to two- and three-dimensional cases. For a multi-dimensional model, the enthalpy transport term needs to be expanded to include the flows in all relevant directions. The flow data may be provided from other physical models, like computational fluid dynamics isothermal simulations [14].

5. Conclusions

The further improvement is demonstrated in the current paper which highlights a novel modelling approach of fluidized beds to incorporate the classical zone method with Aspen Plus interface. A particular advantage of the improved model arises from the thermal reciprocity within a modules formed combustor derived from zone method which breaks the limitation of sequential modular strategy in Aspen Plus. The improved model has been validated by measurement data from a 0.3MW atmospheric bubbling fluidized-bed combustor test rig. Relatively modest computing demand and acceptable accuracy make it possible for the improved model to be incorporated into dynamic simulations of a whole power plant and then used to study the dynamic response performance and operation flexibility of the whole power plant.

Acknowledgements

The authors would like to express their gratitude to the Engineering and Physical Sciences Research Council (EPSRC, EP/M01536X/1), UK for its financial support of this work.

References

- [1] Zhu Q. Developments in circulating fluidised bed combustion. CCC/219, IEA Clean Coal Centre. *IEA Report* 2013.
- [2] Basu P. *Circulating fluidized bed boilers: design, operation and maintenance*. New York: Springer; 2015.
- [3] Lockwood T. Techno-economic analysis of PC versus CFB combustion technology. CCC/226, IEA Clean Coal Centre. *IEA Report* 2013.
- [4] Sotudeh-Gharehaagh R, Legros R, Chaouki J, Paris J. Simulation of circulating fluidized bed reactors using ASPEN PLUS. *Fuel* 1998; 77(4):327-337.
- [5] Nikoo MB, Mahinpey N. Simulation of biomass gasification in fluidized bed reactor using Aspen Plus. *Biomass Bioenergy* 2008; 32:1245-1254.
- [6] Liu B, Yang X, Song W, Lin W. Process simulation of formation and emission of NO and N₂O during coal decoupling combustion in a circulating fluidized bed combustor using Aspen Plus. *Chemical Engineering Science* 2012; 71:375-391.
- [7] Abdelouahed L, Authier O, Mauviel JP, Corriou GV, Dufour A. Detailed modeling of biomass gasification in dual fluidized bed reactors under Aspen Plus. *Energy and Fuel* 2012; 26:3840-3855.
- [8] Snider DM, Clark SM, O'Rourke PJ. Eulerian-Lagrangian method for three-dimensional thermal reacting flow with application to coal gasifiers. *Chemical Engineering Science* 2011; 66:1285-1295.

[9] Wang Q, Yang H, Wang, Lu J, Liu Q, Zhang H, Wei L, Zhang M. Application of CPFD method in the simulation of a circulating fluidized bed with a loop seal Part II – Investigation of solids circulation. *Powder Technology* 2014; 253:822-828.

[10] Lindsay JJ, Morton W, Newey DC. Radiative heat transfer in the freeboard region of a fluidised bed. *Proceedings of the Fifth Engineering Foundation Conference on Fluidization, Engineering Foundation*. New York, NY; 1986, p. 385-392.

[11] Hottel HC, Sarofim AF. *Radiative transfer*. New York: McGraw-Hill; 1967.

[12] Selçuk N, Gogebakan Y, Harmandar H, Altindag H. Effect of recycle on fluidized-bed combustion and emission characteristics of high-sulfur lignite. *Combustion Science & Technology* 2004; 176:959-975.

[13] Aspen Technology Inc. *Aspen Plus V8.8 User Guide*, Cambridge, MA; 2016.

[14] Hu Y, Tan CK, Broughton J, Roach PA. Development of a first-principles hybrid model for large-scale reheating furnaces. *Applied Energy* 2016; 173:555-566.

[15] Rhine JM, Tucker RJ. *Modelling of gas-fired furnaces and boilers*. New York: McGraw-Hill; 1991.

[16] Matthew AD, Tan CK, Roach PA, Ward J, Broughton J, Heeley A. Calculation of the Radiative Heat-Exchange Areas in a Large-Scale Furnace with the Use of the Monte Carlo Method. *Journal of Engineering Physics and Thermophysics* 2014; 87(3):732-742.

[17] Alagoz DE, Kulah G, Selçuk N. A comprehensive fluidized bed combustion model coupled with a radiation model. *Combustion Science and Technology* 2008; 180:910-926.

[18] Hildebrand F. *Introduction to numerical analysis*. Dover Publications; 1987.