



University of HUDDERSFIELD

University of Huddersfield Repository

Sendanayake, Isuru, Asim, Taimoor and Mishra, Rakesh

Development of Novel Vehicle Design Modelling Functions for Quantifying Vehicles' Shapes

Original Citation

Sendanayake, Isuru, Asim, Taimoor and Mishra, Rakesh (2017) Development of Novel Vehicle Design Modelling Functions for Quantifying Vehicles' Shapes. *International Journal of Research, Science, Technology & Management*, 7 (2). pp. 26-31. ISSN 2455-2240

This version is available at <http://eprints.hud.ac.uk/31997/>

The University Repository is a digital collection of the research output of the University, available on Open Access. Copyright and Moral Rights for the items on this site are retained by the individual author and/or other copyright owners. Users may access full items free of charge; copies of full text items generally can be reproduced, displayed or performed and given to third parties in any format or medium for personal research or study, educational or not-for-profit purposes without prior permission or charge, provided:

- The authors, title and full bibliographic details is credited in any copy;
- A hyperlink and/or URL is included for the original metadata page; and
- The content is not changed in any way.

For more information, including our policy and submission procedure, please contact the Repository Team at: E.mailbox@hud.ac.uk.

<http://eprints.hud.ac.uk/>

Development of Novel Vehicle Design Modelling Functions for Quantifying Vehicles' Shapes

Isuru Sendanayake, Taimoor Asim, Rakesh Mishra

University of Huddersfield, Huddersfield, UK

U0857384@unimail.ac.uk, t.asim@hud.ac.uk, r.mishra@hud.ac.uk

ABSTRACT

The inland goods transportation sector has become dominant by high fuel consuming heavy goods vehicles, which are more commonly known as truck-trailer units. Manufacturers have been trying to design aerodynamically efficient truck-trailer units to reduce ever increasing fuel costs. The scope for streamlining the shape of the truck-trailer unit is severely limited due to legally imposed dimensional restrictions. The development of truck-trailer prototypes is both time consuming and costly. Hence, in the present study, a novel mathematical model has been developed to generate the shape of a truck-trailer units. Furthermore, Computational Fluid Dynamics (CFD) based techniques have been employed to analyse the aerodynamic performance of the truck-trailer unit. It has been noticed that the developed vehicle modelling functions are accurate, inexpensive, user-friendly and robust. These vehicle modelling functions are expected to aid the truck-trailer manufacturers for optimising vehicle shapes.

Keywords: Computational Fluid Dynamics (CFD), Drag Force, Shape Functions, Truck-Trailer, Static Pressure, Heavy Goods Vehicles

1. INTRODUCTION

Heavy goods vehicles play an important role when it comes to inland goods transportation around the world. According to Malviya et al [1], around 70% of all the goods are transported by articulated tractor-trailer units. Hence, fuel economy of tractor-trailer units account for a major share of the overall fuel consumption in transportation sector. Marginal aerodynamic design changes have taken place over the years in relation to truck-trailers, mainly due to maximum loading capacity and both practical and legal restrictions. On the other hand, truck-trailer units have increased in length and height over the years, increasing the frontal area, which in-turn

considerably affect the aerodynamics of the whole unit. The increase in the frontal area of these units increases the aerodynamic forces being exerted on various surfaces of these units, increasing the unit's fuel consumption.

Allan [2] has carried out some of the earliest research to determine the relationship between design characteristics and flow distribution in the vicinity of the truck-trailer units. The study indicates that by controlling the flow separation over the truck and the trailer bodies, it is possible to reduce the aerodynamic drag force exerted on the vehicle. The sharp edges on the truck-trailer unit separate the incident flow, thus increasing the drag force being exerted. The study suggests reducing the flow separation by rounding-off the sharp corners in order to reduce the flow separation and the fuel consumption.

Calkins et al [3-4] developed a novel design rule based tool for automotive systems design, named Automobile Design Support System (AutoDSS). This Knowledge-Based Engineering tool enables the users to create a virtual prototype before the manufacturing of the product. The virtual prototype comprises of design rules, product model and the vehicle's geometry. The purpose of this tool is to enable design engineers to decrease the lead time for product development cycle, by examining and evaluating a wide range of design options. One of the functions of the tool is known as the initializer, whereby the body type, dimensions and proportions database is employed via configuration boxes, by sectioning the vehicle.

Rho et al[5] conducted an analytical study on applying a functional design methodology to road vehicle aerodynamic optimization in the initial design stages. The study investigates the concept of employing shape functions in order to control and alter aerodynamic shape parameters, as well as extracting geometric data via simple calculations. Each sector of the vehicle has been categorised as a box model, which made it easy and efficient to represent and modify the details in the configurations.

Malviya[1] has carried out an analytical study for vehicle shape quantification based on the known vehicle parameters, such as dimensions and flow conditions. The effect of vehicle speed, and specially the effects of cross-winds and the resulting effect to the vehicle's stability had been studied in detail. The study uses the approach adopted by Rho et al [5], however, the major limitations of this are:

1. The design methodology is applicable to bluff bodies only, hence, curves that are inherent to modern truck-trailer designs are not modelled
2. The profiling of the truck-trailer unit surfaces is carried out in two dimensions only

As the shapes of the modern truck-trailer units are becoming more and more complex, there is a need to develop sophisticated shape functions that can cater to the various designing complexities involved with the truck-trailer units. In the present study, an attempt has been made to develop a novel vehicle design modelling functions that are accurate and user-friendly, yet robust and inexpensive. Furthermore, CFD based analysis of the developed truck-trailer unit has been carried out in order to establish the usefulness of the design methodology. A brief flow field analysis has been carried out and verified against the available literature to gain confidence in the developed design methodology.

2. VEHICLE DESIGN MODELLING FUNCTIONS

Same as Rho [5] and Malviya [1], the exterior shape of the truck-trailer unit has been represented as a combination of two different shape functions. The first function generates a two dimensional profile that represents the shape of the truck and the trailer unit, while the second function represent the wheel base. In the present study, the truck-trailer unit has been separated into four distinct sections i.e. the truck, the bridge, the trailer and the wheel base, as shown in figure 1. A section function generates the frontal profile for each of these sections. This section function is presented in equation (1), where the frontal profile is generated by modifying the height and the width of each section.

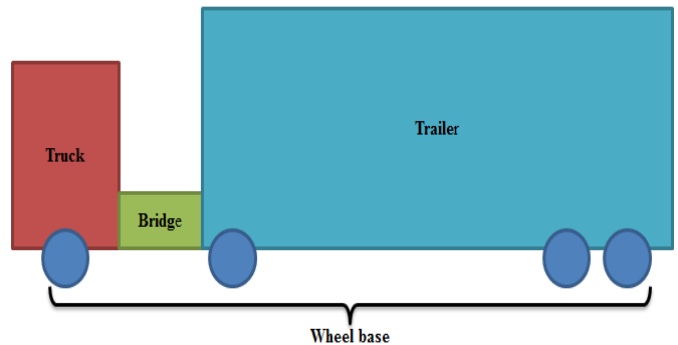

Figure 1 Sections of a truck-trailer unit

$$S_{\text{Section}}(x) = H \times \text{Min} \left\{ \left(\frac{x}{P_1} \right)^{B_1}, 1.0, \left[\frac{1-x}{1-P_2} \right]^{B_2} \right\} \quad (1)[5]$$

where S_{Section} is the section of the surface generated, x is the width of the section in a particular plane, H is the height of the unit, P represents the overall width of the section, while B_1 and B_2 are the gradients of the curves. Equation (1) has been used to define the frontal profile of the truck-trailer unit, as shown in figure 2.

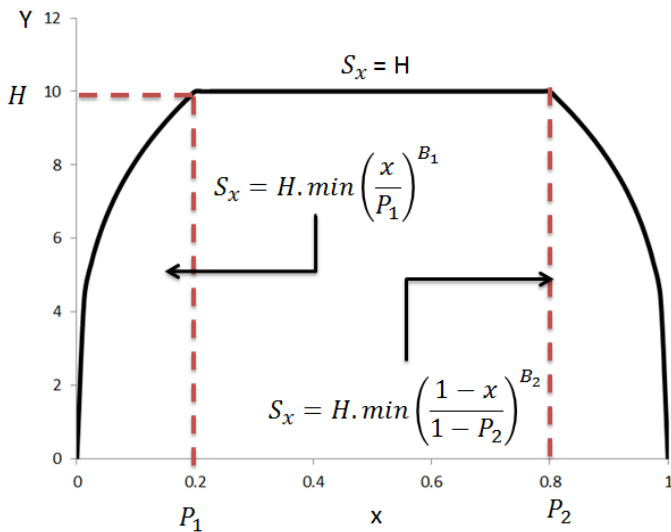

Figure 2 Sample profile for the truck's front surface

It can be seen that the curves are generated on the frontal surface of the truck using the developed shape function. Similarly, equation (2) has been developed to generate the wheel base for the truck-trailer unit, where K controls the vertical position of start and end points of the wheels, ris the wheel radius, x is the length dimension and w_c is the wheel centroid position.

$$S_{\text{Section}}(x) = K - \sqrt{r^2 - (x - w_c)^2} \quad (2)[5]$$

The combination of the above developed shape functions have been used to generate a modern truck-trailer unit, having width and length of 2.49m and 16.28 m respectively. The truck-trailer unit has a teardrop shape of the trailer. In order to generate the 3D shape of the unit, a number of profiles have been generated for the four sections shown in figure 1. These profiles are shown in figure 2, while the developed 3D truck-trailer unit is shown in figure 4. It can be clearly seen that the complex truck-trailer shape has been accurately generated using the developed shape functions.

2. NUMERICAL MODELLING

After creating the truck-trailer's CAD model, a commercial CFD software has been employed to carry out its aerodynamic analysis. For this purpose, a computational domain has been numerically created around the truck-trailer unit, with length, width and height of 13, 11 and 6 times the length of the truck-trailer model respectively. The concept of hybrid meshing has been used in the present study, where 75% of tetrahedral mesh elements have been concentrated in the vicinity of the truck-trailer model. Furthermore, the flow domain has been sub-divided into 1 to 8 million elements, with increments of 1 million. Hence, eight mesh models have been numerically tested, and the drag coefficient of the truck-trailer unit recorded.

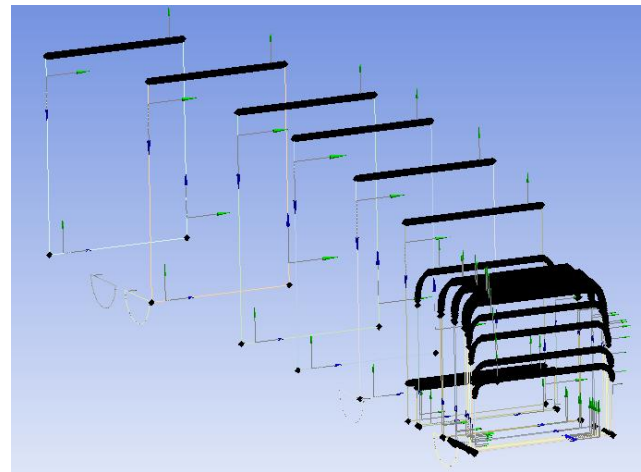

Figure 3 Profiles of the truck-trailer unit

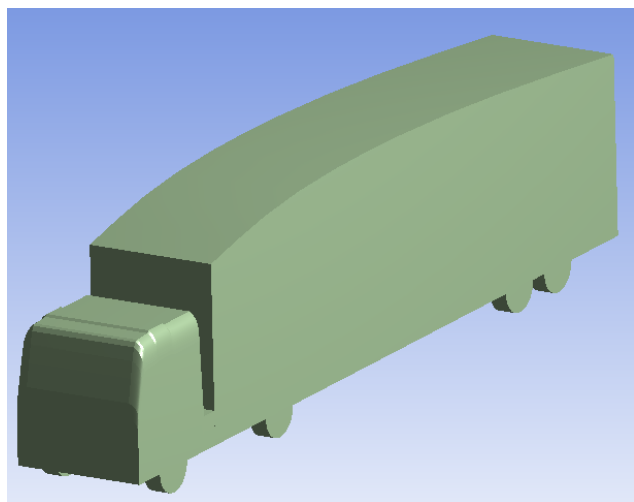

Figure 4 CAD model of the truck-trailer unit

Figure 5 shows the mesh independence test results for the truck-trailer's drag coefficient. It can be seen that there are significant variations in the drag coefficient from 4-7 million mesh models. However, further increasing the mesh density to 8 million changes the drag coefficient of the truck-trailer unit negligibly (0.63%). Hence, the mesh model with 7 million mesh elements has been chosen in the present study for further analysis.

Three dimensional Navier Stokes equations, alongwith the continuity equation, have been numerically solved in an iterative manner for steady flow of air within the flow domain. Air turbulence has been modelled using Shear Stress Transport $k - \omega$ two equation turbulence model due to its superiority in predicting flow separation amongst other two equation turbulence models. Isothermal conditions have been considered in the present study, while the different surfaces of the truck, alongwith the various faces of the domain (except the bottom one) have been modelled as stationary walls, satisfying no-slip boundary condition. The analysis has been carried out at a cruising speed of 40mph. SIMPLE pressure-velocity algorithm has been specified in the present study, while 2nd order upwind spatial discretisation

schemes have been used for pressure, velocity and turbulence properties.

3. RESULTS AND DISCUSSION

Analysing the flow behaviour and its distribution in the vicinity of the truck-trailer unit, figures 6 and 7 depict the variations in the static gauge pressure and in the flow velocity magnitude respectively. It can be clearly seen that the static pressure of air is considerably higher at the front of the truck-trailer unit as a result of rapid deceleration of air particles upon impinging on the front face of the truck-trailer unit. The flow gets separated from the truck and trailer's front top edges where lower static pressure values are recorded. However, the flow reattaches itself to the trailer's top surface downstream. Moreover, as the air particle approach the rear of the truck-trailer unit, due to sudden expansion in the flow area, they get separated from the surface of the truck-trailer unit, forming a wake region, depicting both lower pressure and flow velocity. The wake region is one of the primary reasons behind the high drag coefficients of truck-trailers, as observed by Malviya [1].

The wake region is more evident, and is clearly depicted, in figure 7. The bluff body shape of the truck-trailer model forces the incident flow to separate at the rear edge of the trailer and create the wake region, where the flow velocity has been observed to decrease to 4m/sec as compared to free stream flow velocity of 17m/sec. The flow distribution discussed here is in-line with the findings of Malviya [1] establishing the accurate modelling of the truck-trailer unit using the shape functions developed in the present study.

Further analysing the drag coefficient on the various surfaces of the truck-trailer unit, figure 8 depicts the individual contribution of the key truck-trailer surfaces to the overall drag force coefficient of the whole unit.

The pie chart shows that the front face of the truck is the primary contributor towards the aerodynamic drag (30%), followed by the under body and wheels together (29%). Trailer's rear surface and the gap region contribute 17% and 15% respectively towards the total drag coefficient of the truck-trailer unit. Moreover, it is clear that the contribution to the drag coefficient by the surfaces facing perpendicular to the headwind have marginal contribution (around 1%) for each side.

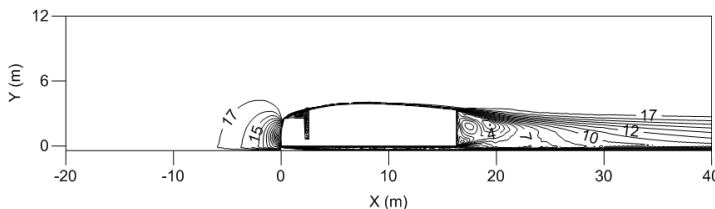

Figure 7 Variations in the flow velocity magnitude (in m/sec) in the vicinity of the truck-trailer unit

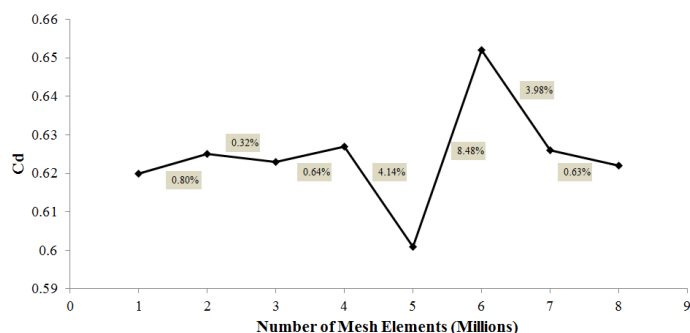

Figure 5 Mesh Independence test results

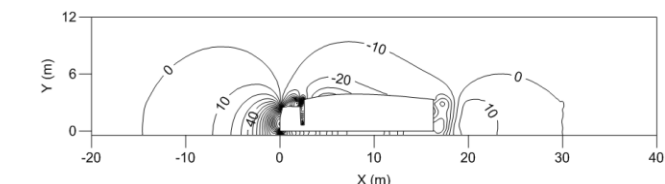

Figure 6 Variations in the static gauge pressure (in Pa) in the vicinity of the truck-trailer unit

4. CONCLUSIONS

A function based mathematical modelling methodology has been developed for generating the key surfaces of a truck-trailer unit having complex shapes. The developed methodology has been tested on a modern truck-trailer unit with teardrop trailer shape. It has been shown that the novel shape functions developed in the present study are capable to generating complex curves, and work well in the 3rd dimension as well. The generated truck-trailer unit has been aerodynamically tested using commercial CFD

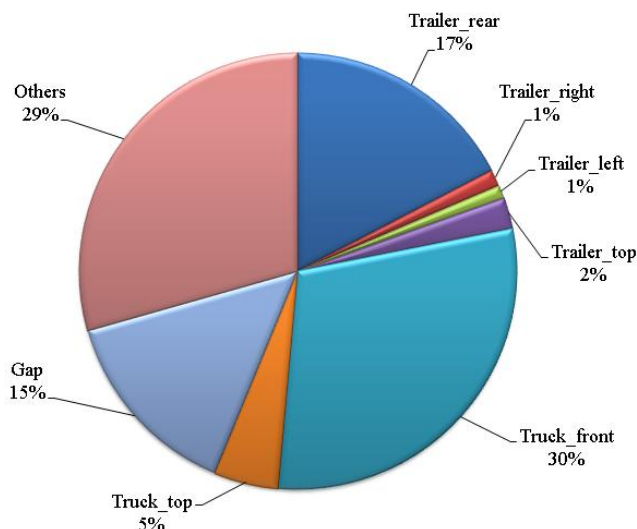

Figure 8 Drag contributions of the key truck-trailer surfaces

software. The flow distribution in the vicinity of the truck-trailer unit has been shown to be in-line with the earlier findings. It can thus be concluded that the developed shape functions are accurate, inexpensive, user-friendly and robust, which can aid the truck-trailer designers immensely.

REFERENCES

[1] Malviya, V. U.(2011) Effects of a Novel Aerodynamic Intervention for Heavy Commercial Vehicles on Fuel Saving and Stability, Ph.D.

Thesis, University of Huddersfield, Huddersfield,
U.K.

[2] Allan, J. W. (1981) Aerodynamic drag and pressure measurements on a simplified tractor-trailer model, *Journal of Wind Engineering and Industrial Aerodynamics*, 9 (1-2) 125-136.

[3] Calkins, D. E. Su, W. Chan, W. T. (1998) A Design Rule Based Tool for Automobile System Design, SAE Technical Paper, 980397, International Congress & Exposition, U.S.A.
A.

[4] Calkins, D.E. Su, W. T. (1998) Cdaero – A Parametric Aerodynamic Drag Prediction Tool, SAE Technical Paper, 980398, International Congress & Exposition, U.S.A.

[5] Rho, J. H. Ku, Y. C. Lee, D. H. Kee, J. D. Kim, K. Y. (2009) Application of Functional Design Method to Road Vehicle Aerodynamic Optimization in Initial Design Stage, SAE World Congress & Exhibition, U.S.