

Accepted Manuscript

The Automotive Order to Delivery Process: How Should It Be Configured For Different Markets?

Philip G Brabazon , Bart L MacCarthy

PII: S0377-2217(17)30350-8
DOI: [10.1016/j.ejor.2017.04.017](https://doi.org/10.1016/j.ejor.2017.04.017)
Reference: EOR 14383



To appear in: *European Journal of Operational Research*

Received date: 10 May 2016
Revised date: 4 April 2017
Accepted date: 6 April 2017

Please cite this article as: Philip G Brabazon , Bart L MacCarthy , The Automotive Order to Delivery Process: How Should It Be Configured For Different Markets?, *European Journal of Operational Research* (2017), doi: [10.1016/j.ejor.2017.04.017](https://doi.org/10.1016/j.ejor.2017.04.017)

This is a PDF file of an unedited manuscript that has been accepted for publication. As a service to our customers we are providing this early version of the manuscript. The manuscript will undergo copyediting, typesetting, and review of the resulting proof before it is published in its final form. Please note that during the production process errors may be discovered which could affect the content, and all legal disclaimers that apply to the journal pertain.

Highlights

- Automotive order-to-delivery system configuration should be tailored to the market
- Two key customer characteristics are willingness to compromise and to wait for a vehicle
- Marginal cost of fulfillment depends greatly on the two customer characteristics
- Nine factors in the order-delivery system alter fulfillment performance

ACCEPTED MANUSCRIPT

The Automotive Order to Delivery Process: How Should It Be Configured For Different Markets?

Philip G Brabazon

(Corresponding author)

Centre for Operational Research and Logistics, University of Portsmouth
Portsmouth Business School
Richmond Building
Portland Street
Portsmouth PO1 3DE
United Kingdom
Tel: +44 (0) 23 9284 4026
Email: Philip.brabazon@port.ac.uk

Bart L MacCarthy

Operations Management and Information Systems Division
Nottingham University Business School
Nottingham NG8 1BB
United Kingdom
Tel: +44 (0) 115 951 4025/4011
Email: bart.maccarthy@nottingham.ac.uk

The order-to-delivery (OTD) process in the volume automotive sector is important for automakers, dealers and customers. It affects the customer's experience with regard to receiving a vehicle that matches their requested specification in a reasonable time and the costs of the automaker in serving the market. OTD processes share similarities across major volume automakers. They are substantial in scale with typically a very large number of vehicle variants and involve interactions between customers, dealers and the automaker. Additionally, automotive markets are heterogeneous. Some customers have little tolerance to compromising on specification and/or waiting for a vehicle whilst others are more tolerant on one or both attributes. This study examines how the OTD process should be configured for different markets. A representative simulation model is used with designed experiments and an innovative statistical analysis method to study the impact of nine OTD configuration factors in three different markets. The study shows that market attributes have a substantial bearing on the dominant modes of fulfillment, on customer-centric performance metrics and on automaker costs. The findings have strong implications for automakers regarding how they configure their OTD processes for different markets and whether they focus on upstream, pre-assembly factors and/or downstream post-assembly factors. This is the first study to use a comprehensive and detailed OTD process model, incorporating a wide range of configuration factors, and assess a full range of performance metrics in a designed simulation study.

Keywords: supply chain management, order fulfillment, simulation, NOLH, CHAID

1. Introduction

The automotive sector accounts for over 7% of world trade (WTO, 2014). Given its importance, it is not surprising that an extensive literature exists relating to its operations. Order-to-Delivery (OTD) is the process that begins with an auto retailer (a dealer) taking a customer order and ends with the customer receiving a vehicle. OTD processes have received less research attention, comparatively, than other areas of auto-industry operations such as new product development (Wynstra et al. 2010), the relationships and interactions with first tier suppliers (Lockstroem et al. 2010), lean initiatives (Jayaram et al. 2008), and supply chain management (González-Benito et al. 2013). In particular, modeling studies that seek to capture the OTD process in an integrated manner are scarce (Volling et al. 2013). This is surprising given the effect of the OTD process on the customer's experience in purchasing a vehicle and the continuing industrial and media interest on issues such as inventory levels in distribution channels and at dealerships, waiting times experienced by customers, and purchase incentives offered by automakers (e.g. Bennett & Rogers 2014; Wernle 2014; Kessler 2015; Tobin 2014). The lack of modeling studies may be partly explained by the complexity of the OTD process and the modeling challenges that arise in seeking to capture its essential elements.

The review by González-Benito et al. (2013) on supply chain management in the automotive sector and the detailed review by Volling et al. (2013) specifically on planning models in the auto-industry, show a dearth of integrated OTD models reported in the literature. The literature review presented below corroborates this scarcity and highlights important gaps in understanding about how large-scale OTD

processes should be configured. This study focuses on the OTD configuration problem. We use a detailed, industry-representative simulation model to investigate the impact of different OTD process configurations and different operating policies in three different market types. We undertake an extensive simulation study with a Near Orthogonal Latin Hypercube (NOLH) experimental design to determine the dominant factors affecting performance in each market. A robust statistical interaction detector, CHAID (Chi-Square Automatic Interaction Detector) is used to analyze the results.

The work makes five contributions to the study and understanding of OTD processes in the volume automotive sector. Firstly, we provide the first reported study that investigates statistically a large number of factors influencing performance of the OTD processes using a large-scale simulation model with a realistic level of variety. Secondly, we examine and compare OTD behavior and performance for different market contexts, characterized by diversity in customer characteristics within and between markets. The study finds the three markets have different dominant modes of fulfillment, have different marginal costs of fulfillment, and different customer service metrics with respect to the waiting times and the degree of compromise experienced by customers. Thirdly, the study identifies the dominant factors affecting OTD performance and behavior with respect to each market. Consequently, different markets need different the OTD process configurations. Fourthly, the study highlights the tension between OTD configurations that minimize cost and those that are best for the customer experience, which makes it challenging for automakers to decide an appropriate configuration. Fifthly, the study provides guidance for automakers in how to configure their OTD processes for different markets.

We organize the paper as follows. Section 2 reviews current understanding of OTD processes in order to identify gaps and define the research objective. Section 3 describes the simulation model and its validation, the design of experiments and the statistical analysis procedures used. Section 4 presents the results, followed in Section 5 by a discussion of findings, research contributions, and their managerial implications. Section 6 concludes with a summary, noting limitations of the study and the potential for similar studies in other complex fulfillment scenarios.

2. Literature review

The literature review begins by defining the term ‘Order-to-Delivery’ (OTD) process as typically used in the volume automotive sector. This first section also identifies similarities and differences in how the OTD process is implemented by automakers. The second section identifies major challenges faced by automakers in operating their OTD processes. The third section reviews previous OTD modeling studies and analyses and compares them in detail. The gaps in the existing studies are identified and the research objective for this study is set.

2.1. *Defining the Order-to-Delivery process*

‘Order-to-Delivery’ is a common term in the automotive sector (e.g. Zhang et al. 2007; Meyr 2004; Holweg 2003) but ‘order fulfillment’ is also used (e.g. Staeblein et al. 2014) and other terms arise, such as

'Market Flexible Customizing System' (Tomino et al. 2009). The objective of the Order-to-Delivery (OTD) process is to provide each customer with the vehicle of his or her chosen specification. A richer explanation, based on Stauntner (2001, cited in Meyr2004), highlights the aims of the process - OTD should achieve short delivery times for customer-specified vehicles, be reliable in keeping to promised delivery dates, and allow customers to change their specification until the last moment.

Sources including Holweg and Jones (2001, cited in Zhang, 2007), Tomino et al. (2009), Aoki et al. (2014) Staeblein et al. (2014) describe the constituents of the contemporary OTD process in different levels of detail, but they are generally consistent. The most detailed is the first source where OTD is described as having seven stages - order entry, order bank, order scheduling, order sequencing, manufacturing, distribution to distribution center (DC) and transportation from DC to dealer.

Researchers report that European and Japanese automakers have similar OTD processes (Staeblein et al. 2014; Aoki et al. 2014; Tomino et al. 2009; Lim et al. 2014). Most customers purchase vehicles through dealers, and the physical flow from suppliers to assembly plant and to customers, which may be via a vehicle holding compound (VHC), is similar. These automakers allow orders in the production plan that are destined for stock to be allocated to customers. They also allow the specification of such vehicles in the production plan to be amended for customers, unless they have reached a point in time when their specifications cannot be altered because of production constraints, i.e. the planned vehicle specification is 'frozen' close to production (Lim et al. 2014, Aoki et al. 2014, Brabazon et al. 2010, Tomino et al. 2009). There are limits to this flexibility, as noted by Lim et al. (2014) who state that Renault constrain the cumulative amendments permitted in the production plan and Toyota restrict changes to +/-10% from the plan agreed at 10 days prior to assembly.

There are differences between automakers. Many, but not all, allow dealers to fulfill a customer with an unsold vehicle or replenishment order in the pipeline taken from another dealer (Williams & Bozon, 2006). Another potentially significant difference relates to the latest opportunity that is offered to dealers to amend a planned vehicle before its specification is frozen ahead of production. German automakers freeze the specification 7 days before production (Staeblein et al. 2014). At Renault it is also 7 days for most assembly plants but for those with distant suppliers it is 4 weeks (Lim et al. 2014). For Toyota, Mitsubishi and Nissan it is 3, 5, and 4 to 6 days, respectively (Tomino et al. 2014).

2.2. *Challenges in the design and management of the OTD process*

Evidence and insights about customer expectations and how well automakers are meeting them is relatively scarce in the research literature. A survey in Germany concluded that the order lead time desired by customers is normally distributed with a mean of 4 to 6 weeks (Stauntner, 2001 cited in Meyr, 2004). In contrast, according to Elias (2002) only 6% of UK car buyers were happy to wait over 4 weeks, with 1 to 2 weeks being the most desired lead time. Most US customers are not prepared to wait beyond 3 weeks as found in a survey by Gartner (cited by Holweg & Pil, 2004). In respect of compromising on vehicle specification, Barbacki & Whitelock (2004) compared the attitude of Turkish and UK customers and

found differences between these markets and within each market. Taken together, the conclusion is that customer attitudes toward lead time and compromise on specification differ between customers within a national market and between markets.

Evidence shows that automakers are not matching customer expectations on lead time. Aoki et al. (2014) present data for different German and Japanese makes and models and they vary greatly, from 2 to over 30 weeks. An independent website gathering data from UK dealers reported the average lead time for a factory supplied new car (as opposed to a vehicle from finished stock) in April 2016 was 13 weeks, with the quickest being the Toyota Auris at 2 weeks, and the longest being the Mercedes GL at 52 weeks (New Car Delivery Times, 2016).

There is very little data on customer compromise in respect of expectations or experience. Elias (2002) reports almost a quarter of UK buyers compromised on at least one feature. Furthermore, nearly half of customers who compromised received compensation in the form of a price discount, an upgrade, a better finance arrangement or a better price for a traded-in vehicle. The scale of compensation is not reported, but it is clear that compromise has a cost to the automaker and/or dealer. Although not in the specific context of the automotive market, Franke et al (2010) provide an explanation as to why customers who configure a product the way they desire may be averse to compromise.

Staeblein et al. (2011) present data showing the number of vehicle configurations manufactured is greatest in the North American region and comment that because “North America is particularly known for its selling from the dealer lot” it is unlikely customers happen to find their preferred specification among the tiny fraction of all variants available at a dealer. They note that “European customers habitually prefer to choose the product they want and to wait for it to be produced” but the evidence from elsewhere is that about half of customers in Europe buy from stock. Volling et al. (2013) state that across Europe as a whole over 50% buy from finished stock with Germany being lower but still above 30%. At an industry event in 2012 it was stated that about 55% of sales in Europe were from stock in 2004, reducing to 45% in 2009 (European vehicle inventory, 2012).

Considering the lead time performance described above, it can be assumed that the phenomenon observed by Fredriksson & Gadde (2005) of customers weighing up lead time against compromise, is widespread. Even though automakers have introduced the ability to amend and sell orders in the production plan, a consequence of the restrictions on amendments described by Tomino et al. (2009) and Lim et al. (2014) could be that a planned vehicle that can be amended to match the customer’s preference will have to wait some time before being assembled.

The volume of finished stock has a significant impact on cost. Automakers have aimed historically at having inventory to cover 60 days of sales, which Holweg & Pil (2004) argued to be excessive. According to press articles automakers want to reduce stock to below 50 days but are some way off with reports of levels in Europe and North America being 64 and 94 days, respectively, in early 2014 (Young 2014, Williams 2014). This oversupply led to retail discounts of 18% in a number of European markets (Williams, 2014).

In summary, the evidence indicates that achieving short and reliable delivery times, avoiding customers compromising on their desired specification, and doing both without incurring excessive costs, are significant challenges faced by automakers.

2.3. *Modeling of the OTD process*

An exhaustive search has identified seven studies that model the automotive OTD process and comply to some degree with the recommendations of Holweg et al. (2005) and Aoki et al. (2014) to take a holistic approach to study interactions between elements of the process. The nature of each study including the aims, the experimental factors investigated and the findings are summarized in Table 1. Details of the model used in each study are presented in Table 2. Importantly, it is clear that simulation is the modeling approach used in each case. This reflects the need to capture the complexity of real-world OTD systems. Six of the studies use discrete event simulation and the other a system dynamics model.

The studies can be divided into those that model upstream supply processes (Volling & Spengler 2011, Lim et al. 2014), downstream distribution processes (Brabazon & MacCarthy 2012, Brabazon et al. 2010, Turner & Williams 2005, Brabazon & MacCarthy 2004), or both (Holweg et al. 2005). All seven include in their model an aspect of the production planning process. With the exception of Holweg et al (2005) the models generate sequences of individual vehicle orders that are allocated to production periods of days (Brabazon & MacCarthy 2012, Brabazon et al. 2010, Turner & Williams 2005), weeks (Lim et al. 2014) or unspecified (Volling & Spengler 2011, Brabazon & MacCarthy 2004). No study goes to the level of modeling the sequence of vehicles on the assembly production line. The studies differ in the level of product variety captured. Only three studies (Williams 2005, Brabazon et al. 2010, Brabazon & MacCarthy 2012) use a realistic level of variety.

There are commonalities but notable differences in how customers are modeled. Apart from Lim et al. (2014) who study a single component, all studies assume customers are seeking a preferred vehicle variant. Only Brabazon & MacCarthy (2012) and Turner & Williams (2005) allow customers to compromise. There are differences in how customer attitude to lead time is modeled. Lim et al. (2014) and Turner & Williams (2005) assume customers are content to wait up to a maximum and these studies use probability distributions to specify each customer's upper limit on waiting time. Brabazon et al. (2010) and Holweg et al. (2005) assume customers will wait any length of time but prefer a vehicle as soon as possible. These two assumptions are also made in the two studies of Brabazon & MacCarthy (2004, 2012) but they also assume customers differ in their dislike of waiting. Volling & Spengler (2011) is the only study that assumes customers have a target lead time and are unhappy with early as well as late delivery.

In summary, there is no standard approach to modeling customers. It is clear that it is unrealistic to assume a customer will not compromise, or to model a customer as having a rigid maximum waiting time. Modeling a customer as being able to trade-off lead time and compromise is preferable. Close examination finds the approach of Brabazon & MacCarthy (2012) is the only one with this capability.

They hypothesized that national populations differ in the relative strengths of their aversions to waiting and to compromise, and recreated the markedly different patterns in real automotive datasets from two markets. Their study set out to examine long tail effects observed in automotive sales in some markets but not in others and demonstrated that market characteristics strongly influence the observed sales patterns. Their approach is selected as the foundation for how customers and markets are modeled in this study.

2.4. Conclusions and gaps

The OTD process in the volume auto-industry comprises a set of inter-connected planning, supply and distribution processes, which aims to deliver an appropriate product to the customer in an acceptable time. Across the automotive sector, the OTD processes of major manufacturers are broadly similar with respect to their structure and the main processes. They differ in terms of their detailed configuration and implementation. Thus, it is valuable to investigate and analyze the impact of different factors on OTD performance.

Previous simulation studies have been identified that examine how to improve customer service and reduce the cost of fulfillment. These studies are exploratory in nature but limited in scope, intended to demonstrate the effect of perhaps a couple of factors or to compare the performance of the OTD process with and without a feature (Table 1). Most are restricted to demonstrating an effect in a limited set of operational conditions and have not used realistic levels of variety (Table 1) and they differ in how many features of the OTD process they model (Table 2). The studies of Turner & Williams (2005) and Brabazon et al. (2010) are the most useful in providing managerial insights as they compare alternative OTD configurations under realistic levels of variety and hence their results can inform choices on detailed OTD configuration. Brabazon et al. (2010) compared the impact on fulfillment performance of two different types of system flexibility, trading between dealers and amendment of vehicles in the production plan, showing the latter to have a more pronounced beneficial effect. However, there is evidence in the literature that national markets and market segments are different with respect to customer expectations and preferences. The implications of these customer differences have not been investigated previously in the literature. Thus, the conclusion is that the existing set of studies provides an incomplete understanding of the OTD process. Lacking in the literature is a study focusing on how to configure the OTD process for different markets. There is value therefore in undertaking a simulation study using experimental design with a model that combines upstream, downstream and customer factors. Consequently, a systematic experimental study that uses a detailed model of the OTD process to evaluate the relative contributions of a large number of OTD design factors to system performance in representative markets is the next logical step in progressing our understanding of this complex process.

2.5. *Research objective*

The objective of this study is to extend the understanding of the OTD process by using a comprehensive and representative simulation model to investigate the impact of OTD design and control factors on performance. The approach taken is to examine the effects of these factors in different types of market where customer populations are heterogeneous both in terms of their tolerances to waiting and to specification compromise. The research question posed for this study is - what are the factors that affect OTD performance in different markets?

ACCEPTED MANUSCRIPT

Table 1 Summary of research aims, findings, factors, and metrics in previous studies of the automotive Order-to-Delivery process

Article	Brabazon & MacCarthy (2004)	Holweg et al (2005)	Turner & Williams (2005)	Brabazon et al (2010)	Volling & Spengler (2014)	Brabazon & MacCarthy (2012)	Lim et al (2014)
Aim(s)	Illustrate how cost and amount of amendment of vehicles in the production plan depends on customer willingness to wait	Demonstrate how the length of planning cycles typically found in OTD systems severely hamper a shift toward built-to-order (BTO) production	Compare fulfilment with and without compound & trading between dealers. Assess additional benefit of reducing vehicle variety	Compare impact on fulfilment of: (a) trading between dealers, (b) amendment of vehicles in the production plan	Demonstrate a two stage fulfilment process, involving (1) immediate lead time promise and (2) subsequent batch allocation to production plan.	Demonstrate fulfilment metrics and sales pattern are dependent on relative strengths of customer aversions to waiting and compromise	Demonstrate how policies on component supply can alter trade-offs between logistics costs and fulfilment metrics
Summary of Findings	Cost of fulfilment increases when more customers are averse to waiting	Current systems are not capable of supporting BTO due to insufficient feedback between supply and demand and reliance on forecasting	The combined compound & trading reduces lost sales and compromise. Reducing variety brings small extra benefit	Both (a) and (b) reduce lead time, but (b) dominates when implemented jointly. Extent of benefit depends greatly on vehicle variety	Achieving compliance with initial lead time promise will incur automaker costs. The two stage process can be tuned to alter the trade-off.	Strength of customer aversions has significant impact on fulfilment and sales pattern	Best compromise between logistics costs and fulfilment is when have small emergency supply margin and small safety stock margin
Key demand features	Customers prefer delivery ASAP ^a , split into two types (a) weakly, (b) strongly averse to waiting. Each customer has a target specification ^b and does not compromise	Customers are modelled in aggregate. Customers prefer delivery ASAP ^a . Two vehicle models (A & B) are demanded by the market, with a 20% step increase in demand for model A during the simulated period	Each customer has max waiting time ^b . Each customer has a target specification ^b and a max. willingness to compromise ^b	Customers prefer delivery ASAP ^a . Each customer has a target specification ^b and does not compromise	Each customer has a preferred lead time ^b and a target specification ^b . Customers do not compromise	Customers prefer delivery ASAP ^a . Each customer has an aversion to waiting ^b . Each customer has a target specification ^b and an aversion to compromise ^b	Each customer requests a lead time between 4 and 8 weeks ^b and has a probability of rejecting ^b if lead time will be longer (i.e. delay)
Product Variety	256 vehicle variants	2 variants	Two levels of variety: 4,680 and 57,905	Multiple levels of variety: 32 to 1,048,576	256 variants	7776 variants	Single variant
Key fulfilment features ^c	Three fulfilment modes (stock, pipeline and BTO); Amending pipeline orders incurs cost	All customers are fulfilled from stock	Multiple fulfilment modes (dealer stock, compound, pipeline, BTO)	Multiple fulfilment modes (dealer stock, compound, pipeline, BTO)	Fulfilment from pipeline only (no stock of finished vehicles)	Multiple fulfilment modes (dealer stock, compound, pipeline, BTO)	Fulfilment from pipeline only (no stock of finished vehicles); Shortest lead time is 4 weeks
Performance measures (Dependent variables)	Lead time; Cost to automaker of amending vehicles in the production plan	Costs to automaker and supplier of (a) wrong stock levels (b) changing production capacity	Stock level; Lost sales; Compromise	Lead time; Stock level; No. of trades; No. of amended vehicles	Factory utilization; component utilization; on-time delivery to customer	Lead time; Proportion compromising; Degree of compromise	Proportion delayed; Proportion lost sales; Component holding cost; Emergency supply cost
Experimental Factors	Proportion of the two types of customer; Upper limit on cost of amending a vehicle	Delays in implementing decisions, strength of feedback, scheduling frequency and period, component stock buffer level	Combined compound and trading between dealers (yes/no); Vehicle variety	Number of amendable vehicle features; Trading between dealers (on/off); Vehicle variety	Weights given to each objective: factory utilization, component utilization, on-time delivery to customer	Customer populations (defined by relative strength of two aversions); Method of selecting vehicle variants for the production plan	Component safety stock margin over forecast; Emergency supply margin over forecast

Notes:

a: ASAP stands for 'as soon as possible'

b: Parameter is stochastic and is sampled from a distribution

c: BTO - a customer order joins at the extreme of the production planning horizon; Pipeline - the customer order is allocated to a replenishment order in the production plan, which may involve amendment;

Stock - a suitable finished vehicle is found for the customer

Table 2 Characteristics of the simulation models used in previous studies of the automotive Order-to-Delivery process

	Brabazon & MacCarthy (2004)	Hobweg et al (2005)	Turner & Williams (2005)	Brabazon et al (2010)	Volling & Spengler (2011)	Brabazon & MacCarthy (2012)	Lim et al (2014)
Type of simulation model and study approach	Discrete Event Simulation, illustrative scenarios analyzed	System Dynamics Simulation, three scenarios analyzed (current state, BTO, balanced)	Discrete Event Simulation, factor levels compared	Discrete Event Simulation, factor levels compared	Discrete Event Simulation, factorial experiment and scenarios analyzed	Discrete Event Simulation, range of customer populations analyzed	Discrete Event Simulation, illustrative scenarios analyzed
Basis of model design	Not specified	Based on six automakers operating in Europe	Based on practices in Europe, US, Japan and Brazil	Based on Ford Europe	Generic ^a	Similar to Brabazon et al (2010)	Based on Renault
OTD features in the model:							
Material / component supply	-	Yes	-	-	Yes	-	Yes
Production planning (e.g. scheduling, sequencing)	Yes	Yes	Yes	Yes	Yes	Yes	Yes
Ability to amend a pipeline order on behalf of a customer	Yes	-	Yes	Yes	-	Yes	Yes
Vehicle manufacture and assembly	-	-	-	-	-	-	-
Outbound logistics	Yes	-	Yes	Yes	-	Yes	-
Stock							
Compound	Yes	Yes	Yes	Yes	-	Yes	-
Dealers have stock	Yes	-	Yes	Yes	-	Yes	-
Ability to search all stock locations on behalf of a customer	Yes	-	Yes	Yes	-	Yes	-
Dealer processes (e.g. ordering replenishment stock)	-	-	Yes	Yes	-	Yes	-

Notes:

a: Data used to test the model is from a German automaker according to Volling et al (2013)

3. Study Methodology

A three-stage methodology is followed. The first stage is to construct a detailed and realistic discrete event simulation model with embedded experimental factors. The selection of experimental factors is motivated by the review of current practice (sections 2.1 and 2.2, and Table 1), the review of past modeling studies (section 2.3 and Table 2), factors identified by OTD practitioners, and the identified gaps in knowledge on the configuration of the OTD process (Section 2.4). The model described below was developed in collaboration with a major volume automaker. The second stage is to validate the model and calibrate two customer aversion factors by comparing model output against actual data for a mainstream vehicle. The third stage is to specify an experimental design that can cope with a large number of factors and answer the research question.

3.1. Model description

The model recreates the lifecycle of a vehicle from appearing in the automaker's production plan up to the point of delivery to the customer. The simulation model, developed in consultation with a major automaker is summarized in Figure 1. The main constituents of the model are the automaker, three dealers, customers, the order bank, the production plan, and a vehicle holding compound (VHC). It incorporates all eight of the OTD features that have been modelled in other studies (Table 2). Like all the earlier studies, the model captures the delay for the assembly process but the fine details of vehicle assembly are omitted. Component suppliers are not modeled explicitly but upstream supply constraints and their resultant delays are modelled. The number of dealers and volume of customers is scaled to be similar to a region or city, with just under 6,000 customers being fulfilled per year.

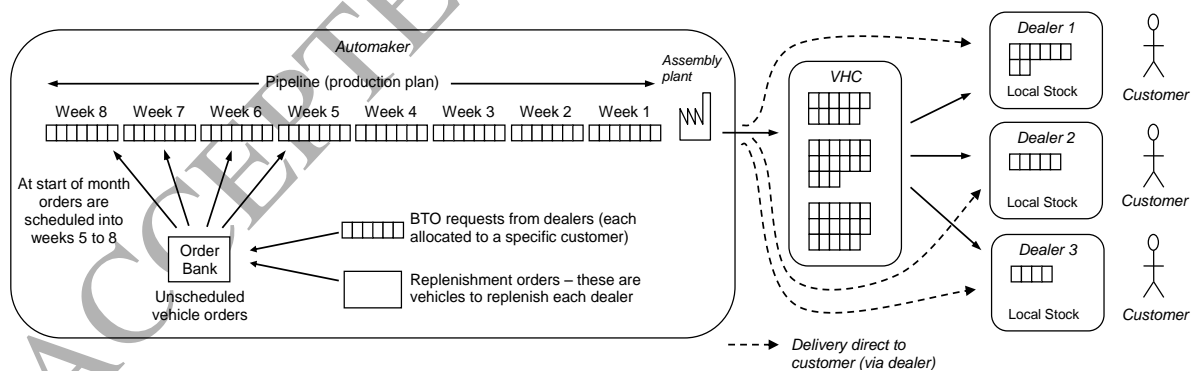

Figure 1 Schematic of the simulated processes. Adapted from Brabazon & MacCarthy (2012)

As time passes, orders for vehicles flow from left to right: along the production plan, through the assembly plant and toward the customer. A customer comes to a dealer, states their wishes and the dealer searches for a vehicle that best matches the customer's preferences in terms of specification and lead

time. The remainder of this section explains the mechanics of the model and the experimental factors incorporated in it.

3.1.1 *Vehicle Architecture*

A vehicle is modeled with five features that capture body shape, engine size, transmission type, interior trim and vehicle color. A customer has a choice of 6 options per feature, giving a total of 7,776 variants in the product range. The variants are horizontally differentiated, i.e. they differ in terms of specification but not price. This number of variants is appropriate for two reasons. Firstly, it is realistic in terms of the main decision features of a vehicle (body shape, engine size, transmission, interior trim, and color). Secondly, although the theoretical variety of some vehicles is very high, the actual variety produced is much less. The level used in the study is of the same order of magnitude as the two datasets reported and analyzed by Brabazon & MacCarthy (2012) which was 7,127 variants in 58,799 sales, and 12,838 in 15,805 sales.

3.1.2 *Stock and the stock replenishment process*

Stock volume is constant due to monthly production being in balance with monthly customer numbers. The volume of stock in the system, which is the sum of unsold finished vehicles in the Vehicle Holding Compound (VHC) and held locally by the dealers, is preset by the *stock* factor.

Every item in stock is owned by one of the three dealers (see Figure 1). On leaving assembly, stock vehicles are transported to the VHC from where they will be, sooner or later, shipped to replenish the owning dealer's local stock, or shipped to the dealer who has sold them. The proportions of a dealer's stock held in the VHC or at the dealership are controlled by a *compound* factor.

The process of ordering replenishment stock by dealers from the automaker is performed on a monthly cycle and starts with each dealer submitting a list of the vehicles they want. The three lists are combined in the order bank with Build-to-Order (BTO) requests from earlier in the month (explained below). The automaker schedules these orders into weeks 5, 6, 7 and 8 of the eight-week production plan (see Figure 1).

A dealer must choose which of the 7,776 variants to order each month. It does this by considering the mix it is targeting – does it want to have a very narrow selection of the most frequently requested variants only, or a wider selection from across the range? Four target mixes are tested in the experimental study, controlled by a *shape* factor (see Appendix 1 for parameter values):

1. Very narrow. Only the highest sellers are ordered.
2. Narrow. The selection is weighted toward the popular variants.
3. Balanced. The selection matches the pattern of customer demand.
4. Broad. A wide selection of variants is included.

A *method* factor controls how the variants for the monthly replenishment list are selected. Two approaches are tested. The first is a systematic method in which the current combined holding is

compared to the target mix (as defined by the *shape* factor). The resulting list will return the mix to be as close as possible to the target mix. This is labeled the *targeted* method and its logic is given in appendix 2. The second approach is to *randomly* choose a variant using the probability distribution defined by the *shape* factor, with each selection being independent. This is a less rigorous approach as it does not take into account the current holding, nor which variants have been selected already. The two methods provide reasonable bounds on likely replenishment behavior.

The simulation model has a *nbo* factor, which controls whether the monthly replenishment list is created by the dealers or by the automaker. When dealers make the selection, they each create a list having considered their own current stock holding. When the automaker does it, one list is created taking into account all current dealer holdings. The automaker's list will be different to the dealer lists when the *targeted* method is used due to the pooling effect, but similar when the *random* method is used.

The process of transporting vehicles from the factory to customers is not studied in the experimental design. Each leg in the logistics network has been given a fixed but representative transfer time.

3.1.3 The customer fulfillment process

When a customer arrives at a dealership, they communicate to the dealer the vehicle specification they are seeking and the dealer establishes the values of the customer's two aversion parameters (see section 3.1.4). The dealer then searches for a vehicle. The two aversion parameters are used to score every vehicle and the one with the lowest combined score is allocated to the customer.

The weeks in the production plan that are searchable by a dealer is controlled by an *openness* factor. When this is set to zero the planned pipeline is not searchable. The factor ranges from zero to 8.

With regard to trading between dealers, the model implements one version of this, termed unconsented trading (Brabazon et al 2010) in which it is not necessary for a vehicle or order exchange to take place. Vehicles in the holding compound can always be traded but never those in a dealer's local stock. The model has a *pipeline trading* factor that enables or disables the ability to trade orders in the production plan.

If, after a search, two or more vehicles have the same lowest score for a customer, the order of preference is: oldest vehicle in the dealer's local stock, oldest in the dealer's compound stock, oldest in the compound from another dealer, the dealer's own replenishment orders in the pipeline, and finally other dealers' replenishment orders. However, it is possible the best option for a customer is to have a BTO vehicle, i.e. a vehicle with the exact specification requested but the order for which must await the next monthly cycle to be planned into the pipeline. The lead time for BTO vehicles is estimated and a score is calculated and compared to the scores for vehicles in stock and in the production plan. Once the best vehicle is allocated, the customer awaits its delivery, which can take some weeks depending from where in the system the customer is fulfilled.

Orders allocated to customers, including BTO vehicles, cannot be amended or traded in the pipeline to satisfy another customer. They are ignored when creating the monthly replenishment list. When they

exit the pipeline, they are shipped to the customer through the requesting dealer without being recorded as stock items.

3.1.4 Order amendment and emulation of upstream supply constraints

The simulation recreates the ability of the automaker to amend an order in the production plan so as to better match a customer's requested specification. The ability to amend a feature is controlled by the *flexibility* factor, which emulates real world phenomena such as component supply constraints (as studied by Lim et al 2014) and assembly plant line balancing limitations. The factor is used as a randomized yes/no test of whether or not a vehicle's feature can be amended.

As a result, of the model calibration exercise (see later) the flexibility factor has a value between 0 and 100%. When it is 100%, a feature of a vehicle in the production plan can always be amended to match the customer's specification for that feature. The lower the percentage, the less likely the feature can be amended. When the Dealer searches backwards through the pipeline on behalf of a customer, every unsold vehicle is inspected to identify how many features need to be amended and if, say, three features need altering, a random number is drawn for each of the three features to determine whether each is permitted to be changed. Therefore, it could be that one of the three features can be but two cannot. Consequently, the *flexibility* factor has an influence over customer waiting times. The lower the percentage, the further back in the pipeline the search will need to go before a vehicle is permitted to be amended to the customer's specification.

The simulation model allows amendments in weeks 2 to 8 of the pipeline, but it additionally includes a *week one* factor to control whether orders can be amended in the final week of the pipeline. The *who* and the *shape* factors are not directly linked to literature but are selected as factors as a result of discussions with OTD practitioners to reflect different approaches adopted in automotive fulfilment systems. The nine experimental factors are summarized in Table 3.

Table 3 Nine experimental OTD factors

Factor	Description	Levels	Settings
Pipeline trading	Trading between dealers	2	On, Off
Method	The logic used each month for selecting the mix of the replenishment orders	2	Random Method, Targeted method
Who	Either the Automaker or the Dealers select the mix of replenishment orders	2	Automaker selects, Dealers select
Week one	When on, a product can be amended within one week prior to production	2	On, Off
Stock volume	Amount of finished stock (across all dealers)	33	From 1 to 1500
Compound	The fraction of dealer stock held in the VHC and the remainder is at dealerships. Stock in the VHC can be traded between dealers	33	From 1% to 100%

Shape	Shape of replenishment distribution which controls the mix of products planned for production	4	1=Very Narrow; 2=Narrow; 3=Balanced; 4=Broad
Flexibility	Emulation of constraints in the pipeline. When set to 10% there is a 0.1 probability that a vehicle's feature can be amended.	11	From 0% to 100%
Openness	Defines the length of the production plan that is visible to the dealers. A dealer can offer a vehicle to a customer from the open segment only.	9	0 = pipeline is closed; 1= week 1 is open; 2 = weeks 1 & 2 are open; etc. up to 8 = all weeks are open

3.1.5 Modeling the Customer

A customer has three attributes. The first is their preferred vehicle specification, i.e. which one of the 7,776 variants they seek. We follow Brabazon & MacCarthy (2012) and assume the demand for variants follows a power law as proposed by Clemons & Gao (2008), which means the shape of demand has a long tail (Anderson 2006) and the likelihood of a variant being sought by a customer is proportional to its popularity rank. This is implemented in the model using a Beta distribution which takes the form of a power function when the second shape parameter, β , is set to 1 (Gupta & Nadarajah, 2004). We ensure there is no correlation between popularity rank and vehicle specification, i.e. it is not the case that vehicles of similar rank have similar specification.

In common with previous studies, (see section 2.3), we assume customers would prefer a vehicle as soon as possible. Furthermore, we assume a customer must be incentivized to wait, incurring a cost to the automaker. This is labeled as their *aversion to waiting* parameter, w , which gauges their dislike of waiting. Again, we follow Brabazon & MacCarthy (2012) and assume the strength of aversion differs within a customer population. We assume $\log(w)$ follows a Normal distribution with 95% of the population having w in a range of four orders of magnitude (e.g. from 0.01 to 100).

As is evidenced in literature, we assume a customer must be incentivized to wait for their vehicle, which incurs a cost to the automaker (Williams, 2014). This is termed the *waiting incentive cost*, C_{wait} , and it is equal to the number of days to wait (n days) multiplied by the customer's aversion (w):

$$C_{wait} = wn \quad \text{Eq.(1)}$$

A similar approach is used to represent each customer's *aversion to compromise*, s , which is the third attribute. As with aversion to waiting, we assume $\log(s)$ is Normally distributed with 95% of the population in a range of four orders of magnitude. In a similar way to Matzke et al (2016) who assume customers need a price discount in order to buy an option not in their initial specification, we assume customers have to be incentivized to compromise on their specification, again incurring a cost to the automaker, which we term the *compromise incentive cost*, C_{comp} . In equation (2) f is the number of product features that are different from the customer's preferred specification. When no features are different, the cost is zero. The largest value of f is 5 as there are five features modeled in a vehicle.

$$C_{comp} = sf \quad \text{Eq.(2)}$$

In the simulation model the means of the two aversion distributions, \bar{w} and \bar{s} , are used as parameters to create different customer populations representing different market types. For example, the market illustrated schematically in Figure 2 is one in which the average customer is less concerned about specification than they are about waiting. The values of \bar{w} and \bar{s} used in the experiments are based on the results of calibrating the model as described later.

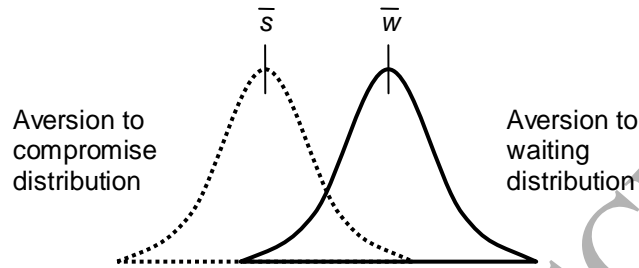

Figure 2 Schematic of customer aversion distributions

3.1.6 Order Fulfilment Cost Index

Although we have insufficient information to estimate the cost of fulfilment in monetary terms, we use the output from the simulation to calculate an *Order Fulfilment Cost index*. This index combines the two customer related costs of compromise and waiting as described above, with the key factor that drives the cost of holding stock – the number of days a vehicle has been in stock when sold to a customer. This is S in equation (3):

$$OFC_{index} = C_{wait} + C_{comp} + S \quad \text{Eq.(3)}$$

Equation (3) is an index of the marginal cost of fulfilment per customer. Should a customer purchase a vehicle that is available straight from assembly with exactly the specification wanted by the customer, the value of their OFC_{index} will be zero. Making a customer wait for a vehicle, or selling a vehicle that has been sitting in stock, and/or requiring the customer to compromise, each incurs cost to the automaker. C_{wait} and C_{comp} are weighted by each customer's individual aversion factors, the means of the distributions of which vary by market (as discussed in section 3.1.5). The number of days a vehicle assigned to a customer has been in stock, S , has no weighting factor, or equivalently a normalized weighting of 1, as it is assumed the cost of holding stock does not vary significantly across markets. Although the literature indicates the significance of these costs, information on their relative magnitudes is scarce. In our experimentation following calibration of the model (see 3.2 below), we observed the cost components to be of similar order of magnitude, as will be shown in the results section (see Table 4). This outcome is consistent with the limited insights about these three costs in the literature (section 2.2). Clearly, an automaker will wish to keep the order fulfilment index small.

Two activities that could be considered to also add marginal costs are amendments and inter-dealer trades. We assume the operational costs per amendment and per trade are insignificant compared to the three costs above. With regard to trades, in the simulation these involve the redirection of vehicles but do not require additional transportation.

3.2. Model validation and calibration of factors

Validation of the simulation model is a methodological aspect that is either not mentioned in the studies reviewed in Tables 1 & 2 or is achieved by having industry executives review a model (Holweg et al. 2005, Lim et al. 2014). As noted, this model was developed in collaboration with a major automaker who provided detailed information on the business processes involved in OTD and its operation in different markets. In this study we have compared the output of the model to real historical data, which is a stronger approach to validating assumptions than used in any of the studies listed in Tables 1 & 2. This has enabled us also to calibrate three of the factors.

For most of the factors it is straightforward to define the levels and range of values with which to experiment, but this is not so for the *flexibility* factor nor for the customer aversion parameters, \bar{w} and \bar{s} . By comparing the model output to historical data we have determined the base settings for these factors: *flexibility* set to 20%, the *average waiting aversion*, \bar{w} , set at 3 and *average compromise aversion*, \bar{s} , set at 30.

In this calibration process the eight other factors are configured to resemble the OTD process of a vehicle model for which we have one year's sales data from a major automaker and the model is run at different values of the two aversions and *flexibility*. The calibration metric is the histogram of vehicles sold at a particular age (in days), shown in Figure 3. The age at sale is a function of several metrics including the mechanism of sale (from stock, from the pipeline, and by BTO) and age of stock, which makes it a succinct indicator for calibration purposes. A negative age occurs if a vehicle is sold while it is in the pipeline (or as a BTO). A positive age occurs if a vehicle is sold from finished stock and reflects the number of days it has been in stock.

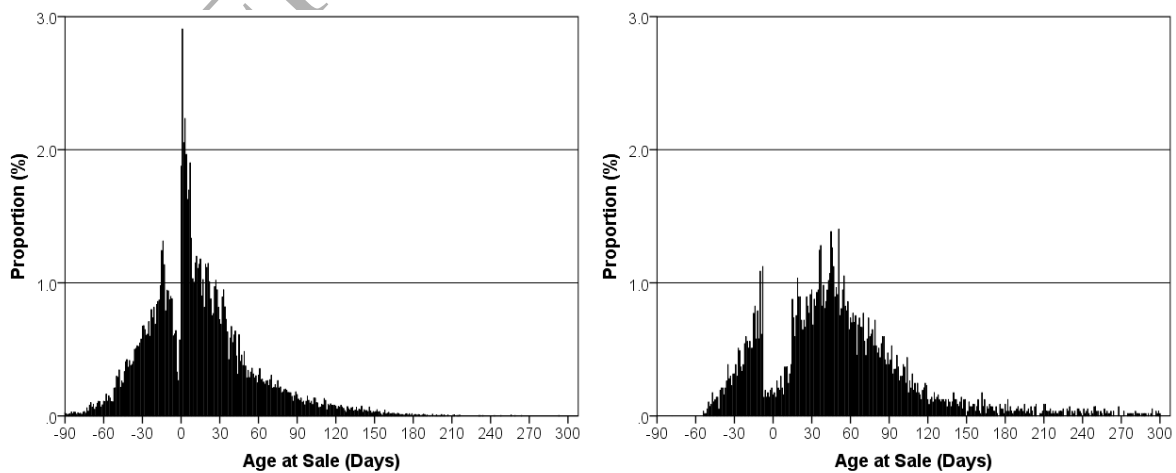

Figure 3 Age of vehicle at sale. Actual data (left) and simulation output (right)

The two plots are not identical but do resemble each other in key respects. As in the real data set, the simulation output has a low level of sales at the most negative age, and sales rise as age approaches zero. Both data sets show a drop in sales before age reaches zero. This is explained by the simulation model and the real world system not being able to amend pipeline orders in the final days before assembly (i.e. the *week one* factor is set to off).

In both data sets, from the age of zero the sales grow quickly to a peak and then decline. The real data has a high peak close to zero, which does not occur in the simulation output, and fewer vehicles are sold beyond 150 days old than in the simulation. Two points can be made about these differences. Firstly, in the simulation model the process of searching for a vehicle on behalf of a customer gives preference to older vehicles. Therefore, the simulation assumes customers are insensitive to age. The higher peak in the actual data for the days just greater than zero may be an indication that at least some customers prefer vehicles straight from assembly. Secondly, vehicle obsolescence is not a factor considered in the simulation and it has no mechanism for offering an age-related discount, which could be an explanation for why the real data records fewer very old vehicle sales.

The base, or calibration, values for *flexibility*, *average waiting aversion*, \bar{w} , and *average compromise aversion*, \bar{s} inform the experimental range. In regard to the *flexibility* factor, had the calibration exercise pointed to a suitable value of, say, 0.2% we would have set an experimental range from 0 to perhaps 1%. With the result being 20%, the chosen range is 0 to 100%.

The two aversion parameters, \bar{w} and \bar{s} , are used to specify a particular market. We have assigned the label ‘Calibration Market’ to a customer population with waiting and compromise aversions set to their base values (3 and 30 respectively). In order to investigate the sensitivity of OTD performance to these two parameters, we have specified two additional markets, one labelled the ‘Specification-Focused Market’ and the other the ‘Demanding Market’. The choice of values for the two aversion factors in these markets are speculative but are motivated by previous work and the experience gained in the calibration exercise. The ‘Specification-Focused Market’, which is inspired by the findings of Brabazon & MacCarthy (2012), is a market in which customers are much more averse to compromise than to waiting time. The aversion to waiting is adjusted to be significantly weaker than in the calibration market ($\bar{w}=0.1$) and the aversion to compromise is adjusted to be somewhat stronger than in the calibration market ($\bar{s}=100$), creating a difference of three orders of magnitude between the parameters. In the ‘Demanding Market’ customers are averse to both waiting and compromise and the two average aversions have equal value ($\bar{w}=30, \bar{s}=30$). The motivation for considering this market is to see how the OTD process copes in a tough operating environment.

3.3. Experimental design

The use of experimental design is one of the aspects that distinguishes this study from the studies reviewed in Tables 1 and 2. Selecting an experimental design to conduct a systematic simulation study of the OTD process is challenging because of the number of factors and the number of values/levels at

which some of the factors can be set, as summarized in Table 3. Appropriate in these circumstances is a Near Orthogonal Latin Hypercube (NOLH) design, which can accommodate many factors at many levels in relatively few trials compared to other designs (Sanchez 2008). It is a strong design for experiments with a complex simulation model and for identifying key factors influencing system behavior. The sacrifice made for the compactness of the NOLH design is that factor interactions are not assessed systematically, as would occur in a full or fractional factorial design. However, by repeating the design to increase the data set, the results can be analyzed using data mining techniques. In this study we build classification trees using the Chi-Square Automatic Interaction Detector (CHAID) technique, which produces a clear depiction of the relationships between the input data and the target outputs, is robust with regard to how inputs are distributed, and is well suited for high-dimensional applications (Berry and Browne, 2006).

The NOLH selected is a 12 column by 33 trials design (Sanchez 2005). As illustrated in Figure 4, each column holds a factor that can take a unique value in each trial. Hence the design reveals the relationship between a factor and an output metric as it varies over up to 33 levels. The nine OTD factors are each assigned to a column. To increase the results set, the design is stacked 5 times, and in each set of 33 trials the factors are assigned to different columns, which improves orthogonality. This gives a total of 165 unique trials. The customer aversions are not included in the NOLH array. Instead, for each market we run all 165 trials to assess whether the importance of a factor changes with market conditions.

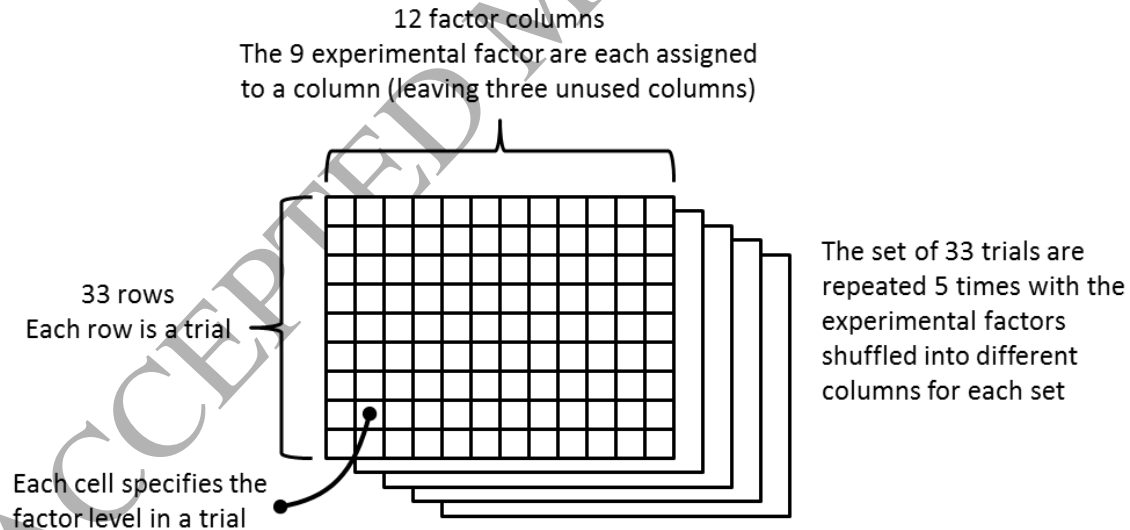

Figure 4 Illustration of how 165 unique trials are specified using the 12x33 NOLH

The model is analyzed as a non-terminating system. At the start of each run, vehicle stock is primed and the pipeline is filled before the first customer arrives. Four system performance aspects are captured and analyzed in the study – the proportion of customers fulfilled by each fulfilment mechanism (from stock, from the pipeline and by BTO); the average lead time experienced by customers (in days); the proportion of customers that compromise on their desired specification and the average number of features on

which they compromise; the order fulfilment cost index and its components (the waiting cost index and the compromise cost index). A warm-up period of 1 year allows the model to reach steady-state and then the method of batch-means is used (Law and Kelton 2000). The statistics from 15 batches of 1 month each are combined to estimate the performance metrics. The variance reduction method of common random numbers (CRN) has been employed for the unique pseudo random sequences, such as the preferred vehicle specification selected by customers. By keeping the same sequence for each random variable in all trials, the CRN approach raises confidence that observed differences in the dependent parameters are due to alterations to the experimental factors rather than to statistical noise (Law and Kelton, 2000). CRN is a widely used and studied technique in the literature (e.g. Glasserman & Yao, 1992; Nakayama 2007; Utterbeeck, Wong, Oudheusden and Cattrysse, 2009).

4. Results

First we use the combined NOLH/CHAID approach to investigate and compare OTD system behavior in each of the three markets. We look at how the OTD factors impact on the critical system performance metrics – the producer’s cost of fulfillment and the customer’s experience in terms of waiting time and the degree of compromise suffered. We then use the approach to identify how the OTD process should be configured for each metric and each market.

4.1. Market conditions and fulfillment

Comparing the results across the three markets shows that the two aversions have substantial impacts on the fulfillment mechanisms used, the degree of specification compromise experienced by customers and on the cost of fulfillment (Table 4). Moving from the specification-focused market (‘A’) to the calibration market (‘B’) and on to the demanding market (‘C’) results in an increase in the average proportion of customers fulfilled from stock with corresponding falls in the use of the other two fulfillment mechanisms. From over 30% in market ‘A’, BTO fulfillment drops to almost zero in market ‘C’. As a consequence, average lead times drop by over 85% in moving from market ‘A’ to ‘C’.

The change in the level of specification compromise experienced by customers is also substantial. In market ‘A’ where customers are willing to wait but are averse to compromise, few of them accept a product with compromise (1.3 %), and for those customers who do, the average number of features compromised is very small (0.016 from a maximum of 5). In the other markets the respective figures are much higher.

The specification-focused market (‘A’) has the lowest incentive costs. These customers need only a small incentive to wait, and because nearly all customers are fulfilled with the variant requested, very little incentive to compromise is required. The calibration market (‘B’) has higher incentive costs, and the demanding market (‘C’), in which the two aversions are equal and strong, has the highest incentive costs.

When stock cost is added, the results across the 165 trials show the Demanding market (‘C’) to have, on average, approximately double the cost of the Calibration market (‘B’), which in turn has

approximately double the cost of the Specification market ('A'). In the next section, we drill down into the experimental results and find that the Specification market costs can be as low as one tenth of the costs of the Calibration market.

Table 4 Fulfillment metrics for the three markets

	Market		
	'A'	'B'	'C'
	Specification- Focused	Calibration	Demanding
Fulfillment mechanisms:			
Stock	19%	62%	92%
Pipeline	50%	32%	3%
BTO proportion	31%	6%	1%
Average Lead Time (days)	36	13	4
Percentage of customers compromising	1.3%	47.5%	79.3%
Average number of features compromised (max 5)	0.016	1.082	2.113
Average waiting incentive cost index (C_{wait})	8	40	120
Average compromise incentive cost index (C_{comp})	1	27	86
Average days in stock (S)	44	42	46
Average order fulfillment cost index (OFC_{index})	53	109	252

4.2. Impact of OTD factors

Using the CHAID method for tree construction, Figure 5 classifies the factors that affect the order fulfillment cost in the specification-focused market ('A'). The top box shows the average cost index across all 165 experimental trials to be 52.9 (rounded to 53 in Table 4). The tree first divides by stock volume, showing this to be the factor that accounts for most of the variation in fulfillment cost across the trials. Ten groups are identified. The stock volume values, average cost index and size of each group are noted in each box in the tree. The branch with the lowest order fulfillment cost index is on the left of the

chart, grouping 15 trials in which stock volume is less than or equal to 96 and with an average cost index of 11.4. Looking across the other boxes at this level shows the cost index rising as stock increases.

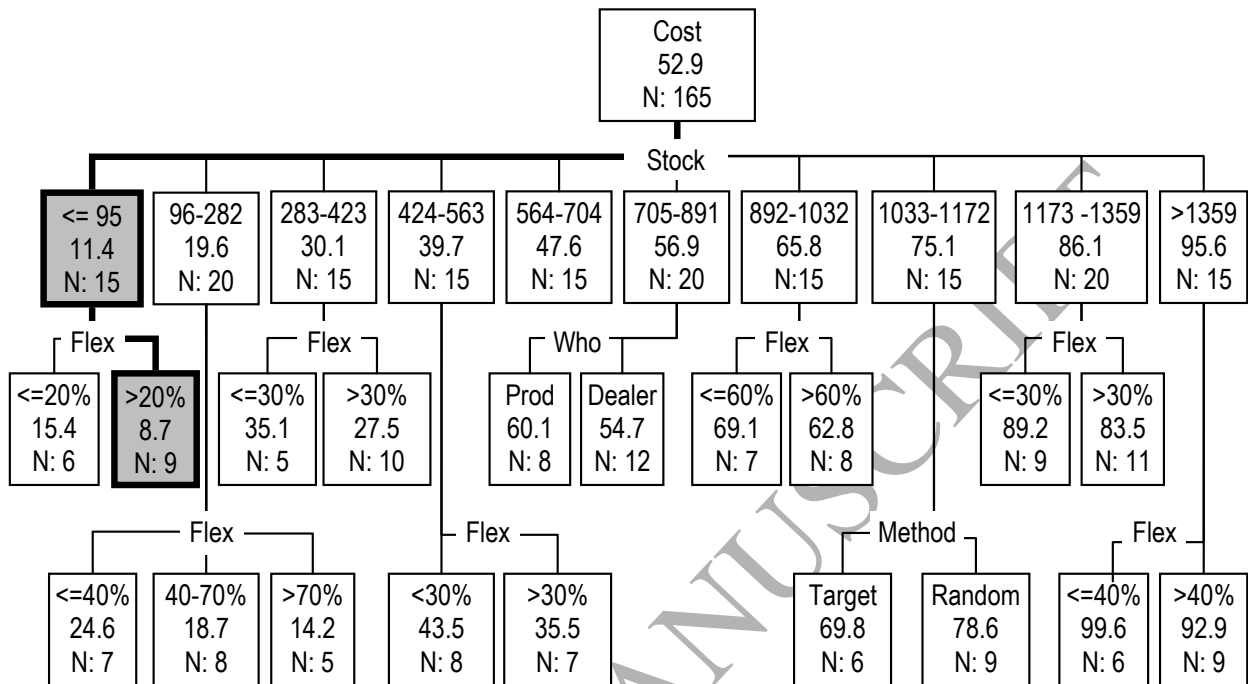

Figure 5 Specification-Focused Market ('A') Fulfillment Incentive Cost Tree

Nine of the ten branches divide at the second level. Seven are split by the *flexibility* factor, one by the *method* factor and one by *who* selects replenishment orders. The leftmost branch at the first level is one of those split by *flexibility*, with its 15 trials divided into a group of 6 in which flexibility is less than or equal to 20%, and a group of 9 in which flexibility is greater than 20%. The average cost index for the group of 9 is 8.7, and it is this leaf that has the lowest cost in the whole tree. Therefore, to achieve the lowest marginal order fulfillment cost in the specification market it is necessary to have more than 20% flexibility and to have 96 or fewer vehicles in total stock. This branch is emboldened in the diagram.

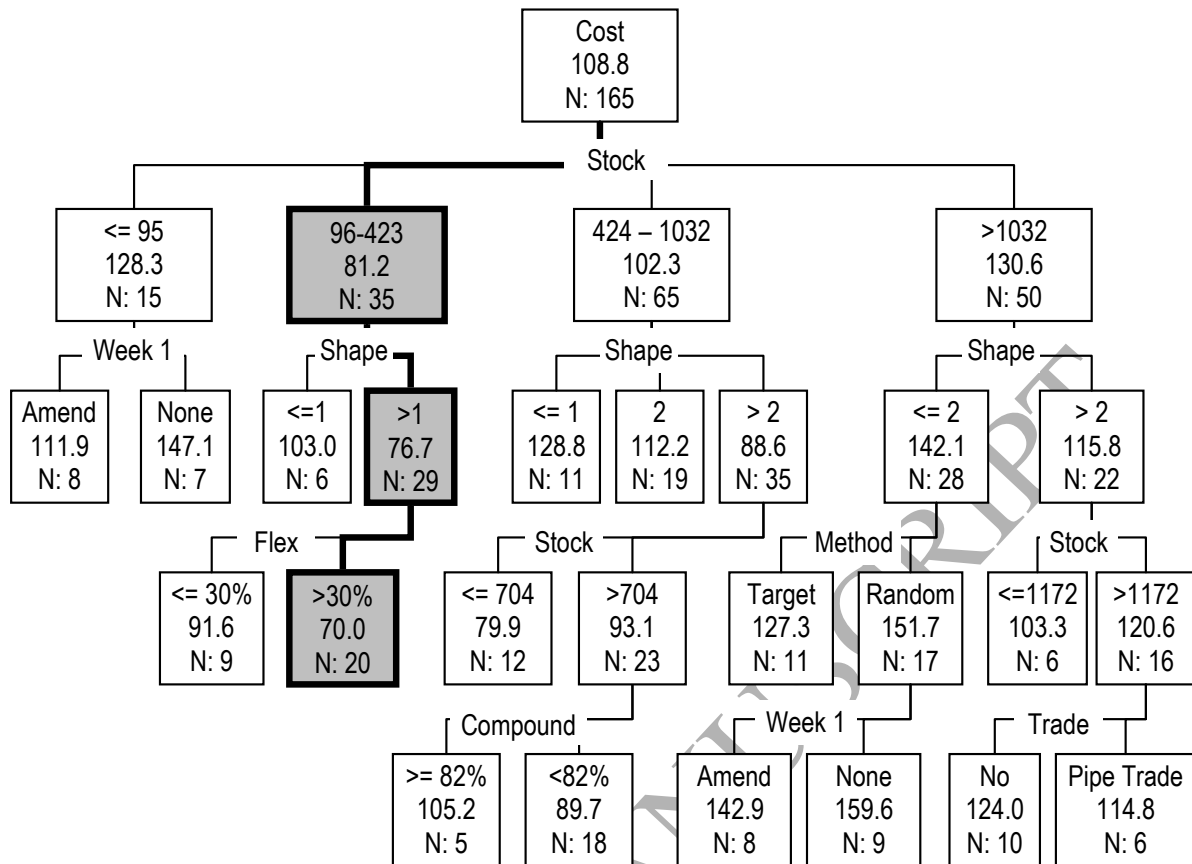

Figure 6 Calibration Market ('B') Fulfillment Incentive Cost Tree

The equivalent classification trees for the other two market conditions are presented in Figures 6 and 7. Comparing the lowest cost leaf in each tree shows the Demanding Market (lowest index of 124.4) to be almost twice as costly as the Calibration market (70). However, the ratio between the lowest of the Calibration and Specification (8.7) markets is approaching ten.

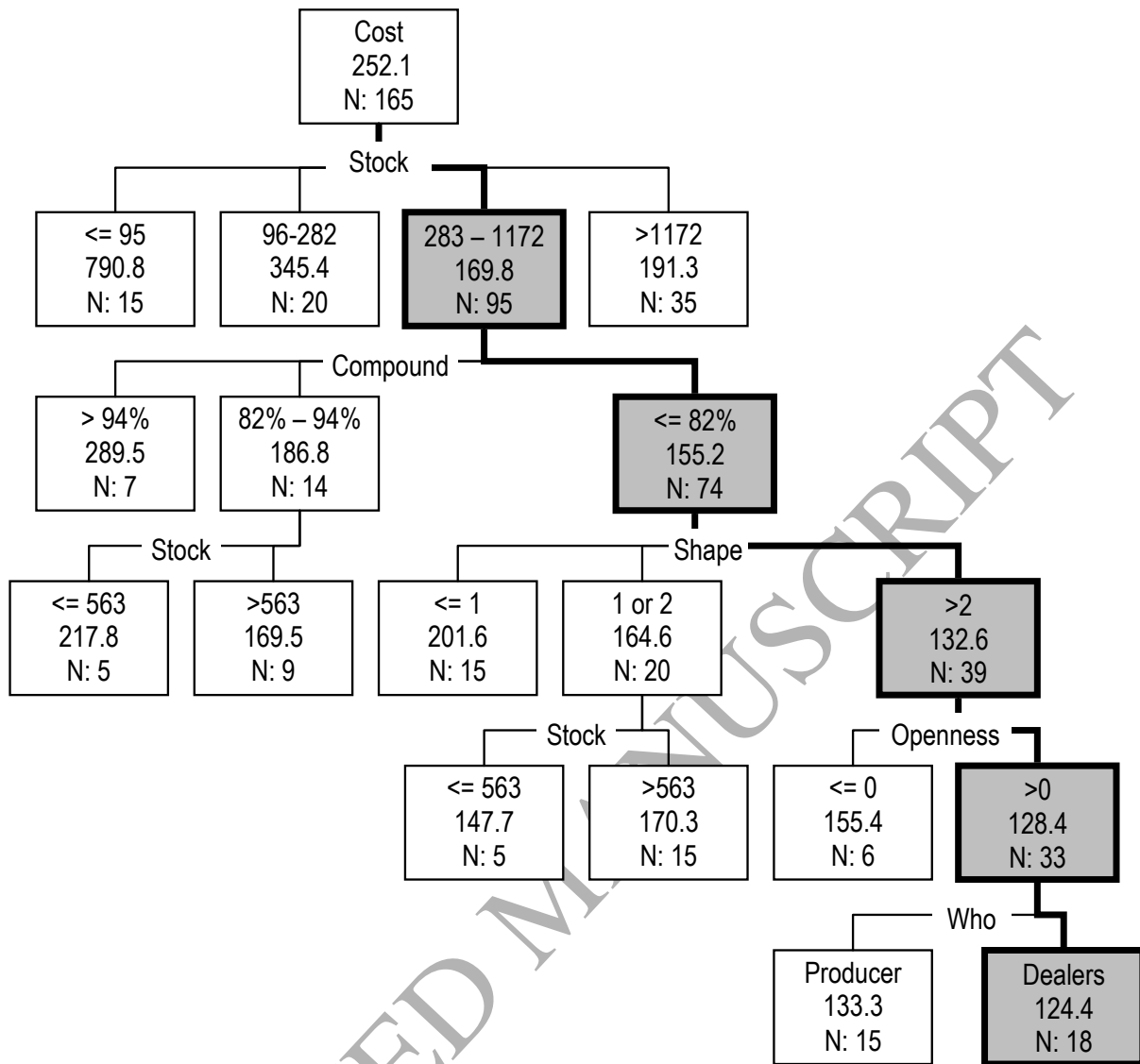

Figure 7 Demanding Market (C) Fulfillment Incentive Cost Tree

Trees for customer waiting time and degree of compromise experienced (in terms of the average number of product features different to a customer's preferred specification) have also been created but are not reproduced here for brevity. For each tree the branch leading to the best leaf is summarized in Table 5. Importantly, the table reveals both consistency and conflicts between the metrics in the different markets.

Although a stacked design has been used, the compactness of the NOLH matrix means that only a limited number of possible combinations of factor settings are tested and that interactions are unquantified. For example, in the case of the Calibration market, the best combination of settings of the three factors occurred in 12% of the trials (20 from 165), hence this combination was not exposed to all settings of other factors. To increase confidence in the findings, one set of 33 trials is re-run in which the other factors keep their original settings and hence vary over their entire experimental ranges, but the three factors are restricted to their best ranges, i.e. *stock* varies only between 96 and 423, *shape* varies from

2 to 4, and *flexibility* is greater than 30%. The box plots in Figure 8 compare the results of the original and re-run sets of 33 trials, and give confidence that no interaction has a significant effect. Re-runs for other markets and metrics indicate similar confidence in the CHAID results.

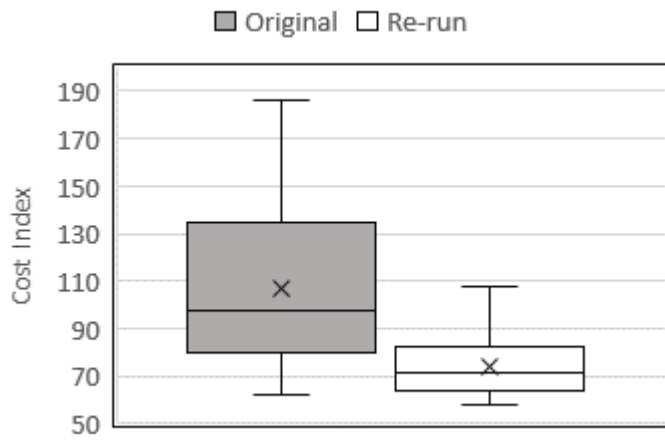

Figure 8 Box plots of cost index for two sets of 33 trials, for the Calibration market

Table 5 Best branch for three metrics in each market

	Market					
	'A' – Specification-Focused		'B' - Calibration		'C' - Demanding	
Order	Stock volume	≤ 95	Stock volume	96-423	Stock volume	283-1172
Fulfillment cost index	Flexibility	$> 20\%$	Shape	> 1	Compound	$\leq 82\%$
			Recon Flex	$> 30\%$	Shape	> 2
					Openness	> 0
				Who	<i>Dealer</i>	
	^a Cost 8.68, n=9		Cost 70.04, n=20		Cost 124.36, n=18	
Customer lead time	Flexibility	$> 70\%$	Stock volume	> 704	Stock volume	> 891
	Openness	> 1	Shape	> 2	Compound	$\leq 64\%$
	Week One	<i>Amend</i>	Week One	<i>Amend</i>	Shape	> 2
	Pipeline Trading	<i>True</i>	Method	<i>Targeted</i>		
	Stock volume	> 704				
	Lead time 13.76, n=9		Lead time 7.39, n=10		Lead time 1.91, n=19	
Customer specification compromise	Flexibility	$> 60\%$	Shape	> 2	Shape	> 2
	Openness	> 5	Stock volume	> 891	Stock volume	> 704
	Shape	≤ 2			Compound	$> 94\%$
	Method	<i>Targeted</i>				
	Features different 0.005, n=7		Features different 0.658, n=31		Features different 1.095, n=5	

^a At the bottom of each cell is the average value for the metric and the number of observations in the final leaf of the branch

The first observation is that stock volume is a key factor in all three markets and impacts all metrics. Only for the compromise metric in the specification-focused market ('A') does it not appear in the best branch, but otherwise it is the first factor dividing a tree in more than half the cases. Stock volume should be different for each market condition to minimize the incentive cost. In market 'A' the lowest incentive cost is achieved with stock less than or equal to 95, but in the calibration market ('B') it is with stock between 96 and 423 and in the demanding market ('C') it should be in the range 283 to 1172.

Also evident from the results in Table 5 is that the three metrics can be in conflict in terms of the stock level that achieves the lowest costs. This is the case in the specification market 'A' in which a stock of *more than 704* gives the shortest lead time, while a stock of *96 or less* gives the lowest cost. Maintaining the volume of stock to minimize lead time would result in the fulfilment cost index being 56.9 or higher (from Figure 5), which is almost an 800% increase over the lowest achievable cost. There is conflict also for the metrics in the calibration market ('B'), with higher stock levels needed to shorten lead time and

reduce compromise, but lower levels needed to reduce cost. Only in the demanding market ('C') is there harmony, with all three metrics benefitting from high stock levels.

Aside from stock volume, the factors that have most influence on the performance metrics in the specification-focused market ('A') are pipeline related factors, specifically *flexibility*, *openness* of the pipeline, amendments in *week one*, and *pipeline trading*. For this market, it is best to have the pipeline visible to the dealers and to have a high level of ability to amend orders in the plan so as to simultaneously give customers the specification they seek, whilst reducing fulfilment costs and lead times.

In contrast, in the demanding market ('C') it is stock related factors that alter performance metrics the most. In this market, as well as stock volume, it is the *shape* factor and the *compound* factor (which controls the proportion of stock held in the VHC) that are important. In the demanding market, it is best for dealers to avoid having a narrow mix. They should target the same or a slightly broader distribution compared to the customer demand. Having a shared VHC is beneficial, and to reduce compromise it is best to store nearly all stock there. However, the time to transfer from the compound is unattractive to demanding customers, and the lowest fulfilment cost index is achieved by holding nearly a third of stock locally. It is also the case that dealers benefit from being responsible for selecting their replenishment orders, rather than the automaker doing this (which is controlled by the *who* factor). Although having the automaker select orders should give a better overall mix in the compound, the results indicate that dealer self-selection creates a better local mix. The improved local mix, in tandem with trading of compound vehicles, is a superior combination of factors.

It is notable that all nine experimental factors have influence over fulfillment performance in at least one of the markets. This finding, together with the fact the best OTD configuration is different in each market and for each metric, is evidence of the challenges in designing an OTD process with appropriate operating policies to match market characteristics.

5. Discussion and managerial implications

To study the OTD process it is recommended to use a holistic approach (Holweg et al. 2005, Aoki et al. 2014). This study demonstrates both the necessity for, and the benefits of doing so to understand how a large-scale OTD process should be configured for different markets. The contributions from the study stem from the detail captured in the discrete event simulation model including the modeling of customers, the choice and design of the experimental approach, and the extent of the experimental study. The model has greater coverage of the OTD process, incorporating a greater range of factors, a number of which have never been studied before. It assesses more performance metrics than previously considered and uses designed experiments to understand system behavior and performance. It is the first to examine how a large scale OTD process performs in different markets with heterogeneity in customer attitudes to waiting and compromise.

The validity of the simulation model is underpinned by it being developed and refined within a stream of research that involved a major automaker. Its relevance to the sector is evident from the fact that it

incorporates all the main processes described in the contemporary literature on OTD practices of the major automakers, as confirmed by Lim et al (2014). The modeling of customers is an integral part of the holistic analysis. The study models customers as having an aversion to waiting and an independent aversion to compromise. It captures customer heterogeneity within a customer population, and examines performance in different types of markets. The validity of the combined OTD and customer models is demonstrated by the level of agreement achieved in calibration against actual historical data.

The challenge of studying and analyzing a large number of factors has been met by using the NOLH design (Sanchez 2008) and the CHAID technique (Berry & Browne, 2006). The former has been developed specifically for simulation based multi-factor experiments while the latter originates and has gained significant prominence in the field of data mining. Both are proven approaches and can be expected to be adopted more widely in large-scale simulation studies.

5.1. Contributions and Managerial Implications

The first insight from the study is that market attributes in terms of customer aversions to waiting and to specification compromise have a substantial bearing on the modes of fulfilment and on system performance metrics. Knowing the dominant modes of fulfilment in any market provides important information for the automaker in considering the design and management of the fulfilment system. This is revealed clearly in a comparison of the two most different markets, 'A' and 'C'. For a *demanding* market ('C') in which customers are strongly averse to both waiting and compromise, the dominant mode of fulfilment is from stock. In contrast, for a *specification-focused* market ('A'), where customers are much more strongly averse to compromise than waiting, stock fulfilment plays a minor role and it is pipeline fulfilment that is the dominant fulfilment mode. In terms of marginal cost, lead-time and customer compromise, these two markets perform quite differently. Within the experiments, the lowest fulfilment cost index for the *demanding* market ('C') is over 14 times larger than the lowest cost for the *specification-focused* market ('A'). However, its shortest lead time is 7 times less than for market 'A'. The minimum average compromise in market 'C' was just over 1 feature (1.095), whereas it was almost zero (0.005 features) in 'A'. The implications are that even when the OTD process is configured appropriately for each type of market, the performance metrics will vary substantially from market to market. The relative cost of serving markets with different characteristics will be very different and the customer-centric metrics of expected lead times and level of compromise experienced will also vary depending on the market.

The question for automakers is how should the OTD process be configured for different markets? Previous literature has been relatively weak in providing much if any guidance to automakers on how to configure their OTD processes. A clear insight from this study is that automakers face a number of dilemmas. The OTD configuration that achieves the lowest fulfilment cost in a market does not necessarily achieve the best customer-centric metrics with regard to lead-time and the level of compromise experienced by customers. This is the case in the *specification-focused* ('A') and *calibration* ('B')

markets in which the best customer metrics would be achieved by larger volumes of stock but with negative consequences for the cost metric. If a customer's loyalty and future repurchase decision is sensitive to their experience of either compromise and/or waiting time in their current purchase, then the automaker and dealers have a dilemma – do they keep stock low to reduce the cost of the current transaction, but in so doing put future revenues at risk, or hold more stock and incur higher costs now for the sake of further sales at a later time?

A less dramatic conflict in OTD configuration is observed in the *demanding* market ('C'). All performance metrics benefit from holding stock, but there is a balance to be struck in where the stock is held – locally at each dealer or remotely in the shared vehicle holding compound. Lead time is reduced by increasing the proportion held locally, but compromise and cost are reduced by decreasing local stock.

These dilemmas illustrate the complexity of the OTD process and the challenges in configuring it appropriately, which are also evident from the fact that every one of the nine OTD factors studied impacted performance in some way, as shown by the CHAID analysis. Each factor affected one or more metrics in one or more of the three markets. The interplay between the heterogeneity in customer attributes in any market and the different potential modes of fulfillment makes OTD process configuration very challenging to get right. The findings from the study with regard to different markets can be formulated as guidance for automakers, as follows:

- When serving a *specification-focused* market ('A') or *calibration* market ('B') the agenda for automakers should be to focus on upstream, pre-assembly, OTD factors. Increasing flexibility in the production plan and responsiveness of supply should be priorities. This includes being able to amend orders in the production plan into any specification, and being able to do so right up until the last moment before assembly. Dealers should have visibility of the production plan and be given the tools to amend and trade orders. For market 'A' the stock of finished vehicles should be restricted to the most frequently demanded vehicle configurations, but a wider selection is beneficial in market 'B'. To reduce cost, a small holding of stock is recommended, but a larger volume will reduce fulfillment lead time in both markets 'A' and 'B' and reduce compromise in market 'B'.
- When serving a *demanding* market ('C') the automaker's agenda should be to focus on the downstream, post-assembly, factors of the OTD process. It is recommended to hold a large volume of stock that is representative of the full range of vehicle specifications being demanded, rather than just the top sellers. The majority should be held at a VHC so that dealers can trade them.

Most of the previous literature has not provided any specific guidance on OTD systems design or how OTD systems should be configured. With the insights provided by this large-scale experimental analysis of a detailed model with a realistic level of variety, we can re-evaluate the relatively limited guidance provided in some previous studies. It is clear that previous studies lacked the appreciation of how important market characteristics can be. It is now evident that the recommendation from Lim et al (2014) to increase flexibility in upstream component supply is relevant to markets types 'A' and 'B'. The use of vehicle compounds and trading of finished vehicles between dealers (Brabazon et al, 2010; Turner &

Williams, 2005) is appropriate for market 'C'. The other recommendation of Brabazon et al (2010) of enabling amendments in the pipeline is applicable to market types 'A' and 'B'. It is important to note that it is not a simple case of our results contradicting or confirming existing guidance. It is that the very limited understanding provided from a small number previous studies is superseded by the much more exhaustive and detailed study presented here. The extent of our new contributions to the understanding of the automotive OTD process shows both the need for, and the benefits of, a holistic approach to studying operational processes of similar complexity. Combining NOLH and CHAID provides new opportunities to use simulation to study such systems in a scientific and innovative way.

5.2. *Limitations and future work*

The guidance for markets 'A' and 'B' prioritizes upstream OTD factors, while it is downstream factors that are targeted for market 'C'. On the surface, it appears that market 'C' cannot benefit from upstream capabilities, but this may not always be the case. In this study, the ability to amend a vehicle in the production plan was used only when selling an order to a customer. What if this functionality was used to amend unsold orders which are about to go into assembly and then stock? In other words, just before entering assembly, a replenishment order would be amended to be the specification most needed to maintain the desired stock mix. For market 'C' the range of vehicle specifications in stock affects cost, lead time and compromise and hence this upstream ability to amend orders could be used to advantage. The magnitude of the benefit is a matter for further study.

The calibration of the model against actual data, which is a further strength of this study, has enabled the aversion factors to be quantified for the calibration market. The aversion values used for the two other markets were speculative to some degree. Hence, the quantification of aversions is an area for future study but we note that the approach can be applied to investigate a market of any type once aversion factors are quantified. It is also possible that the modeling of aversions could be further developed. In this study it is assumed a customer has the same strength of aversion for all features, i.e. they are as unhappy with a change in body shape as with a change in engine type. It is also assumed a customer has a uniform aversion to any change in a feature (e.g. if they prefer a 4dr body, they are as unhappy to change to a 3dr as they are to change to a 5dr). Further work could also refine these assumptions.

In common with the previous literature, this study has not differentiated products with respect to price. This has been for model tractability reasons and the lack of data for calibration purposes. To include product price would increase the complexity of the customer decision making model. However, it is speculated the impact of introducing price differentiation on the performance of the OTD process may be consistent with increasing customer aversion to specification compromise. If the product range is differentiated by price, it is possible that customers who have selected a preferred vehicle configuration may perceive lower priced options as offering less value for money. Hence, a consequence of increasing the price difference between options is that customers become more reluctant to shift from their

preferred selections. In other words, greater price differentiation leads to a general raising of aversion to compromise within the customer market. The investigation of price differentiation, customer behavior and the above hypothesis are recommended as areas for further work.

A simplification in the model is that demand has been assumed to be constant, whereas markets often exhibit some form of seasonal pattern. The study results suggest the implications of seasonality for OTD performance depend on the strategy applied by the automaker. If production rate is near constant, finished stock volume will fluctuate over the seasonal period. By establishing that OTD metrics are strongly sensitive to stock volume, the insight from this study is that metrics will also fluctuate over the season. It is anticipated that metrics will alter to a lesser extent if the automaker pursues the alternative strategy of adjusting production rate so as to keep stock volume near constant. The implications for OTD performance of how automakers cope with seasonality is a topic for further work.

This study has not sought to derive an optimal configuration but instead has focused on a comprehensive analysis of the dominant factors influencing performance in different markets types. There is scope to undertake a study in the future that seeks to determine an optimum configuration across multiple criteria for a specific market. The study here indicates the key factors that need to be modelled.

6. Conclusions

An extensive and representative simulation model of a large-scale automotive OTD system has been used to examine the impact of nine system factors on fulfillment performance. The study has identified the dominant factors affecting fulfillment under different market conditions. The ideal capabilities of the OTD process depend on the market characteristics and on which performance metric is prioritized. The implications of the study have been debated from the perspective of the automaker seeking to satisfy heterogeneous customer populations in markets with different characteristics. The use of the NOLH/CAID experimental simulation approach has potential applications in analyzing OTD processes in other sectors that have complex products, diversity and heterogeneity in markets, and significant planning pipelines.

Appendix A

Customer demand and the replenishment distributions are Beta distributions with the following parameters:

1. Very narrow. $\alpha = 0.047, \beta = 1$
2. Narrow. $\alpha = 0.131, \beta = 1$
3. Balanced (same as customer demand). $\alpha = 0.296, \beta = 1$
4. Broad. $\alpha = 0.557, \beta = 1$

Appendix B

When using the *targeted* replenishment method, a dealer generates its monthly list of replenishment orders by using an approach based on the *forward sales coverage* concept. If the total number of a specific variant i held by a dealer in stock and pipeline replenishment orders is a_i and the probability of a customer requesting this variant is p_i then the forward sales coverage of this variant fsc_i is the expected number of customers which need to be served for the variant's holding to be sold (Eq. B.1).

$$fsc_i = \frac{a_i}{p_i} \quad \text{Eq. (B.1)}$$

The *forward sales coverage* concept is adapted into *target coverage*. Instead of p_i the calculation uses the variant's target probability t_i which is defined by the shape of the target distribution described in section 3, and fsc_i is replaced by target coverage tc_i .

Once a month the automaker tells the dealer how many replenishment orders it is to have and requests from the dealer the list of variants it wants. The list, l , is compiled as follows:

Step 1: Receive from the automaker the number of replenishment orders required this month.

Step 2: Start with an empty replenishment list. Initialise l_i to zero for all i .

Step 3: For all variants, sum its holding a_i and number of requests so far on the list l_i .

Step 4: For each variant calculate tc_i by incrementing its combined holding and requested number by 1, using equation (5).

Step 5: Identify the variant i that gives the lowest target coverage tc_i .

Step 6: Increment the request for this variant l_i .

Step 7: Decrement the number of replenishment orders remaining to be requested.

Step 8: If the number of replenishment orders remaining is greater than zero, go to step 3, otherwise send the list to the automaker.

$$tc_i = \frac{(a_i + l_i + 1)}{t_i} \quad (5)$$

References

- Anderson, C. (2006). *The long tail : how endless choice is creating unlimited demand*. London : Random House Business.
- Aoki, K., Staebelin, T., & Tomino, T. (2014). Monozukuri capability to address product variety: A comparison between Japanese and German automotive makers. *International Journal of Production Economics*, 147(Part B), 373–384. <http://doi.org/10.1016/j.ijpe.2013.02.026>
- Bardakci, A., & Whitelock, J. (2004). How “ready” are customers for mass customisation? An exploratory investigation. *European Journal of Marketing*, 38(11/12), 1396-1416. doi:10.1108/03090560410560164
- Bennett J., C. R. (2014, February 11). Car makers snip pricing now to avoid haircuts later. *The Wall Street Journal*. Retrieved from www.wsj.com/articles/SB10001424052702304558804579377293202213988

- Berry, M. W., & Browne, M. (2006). *Lecture notes in data mining*. [electronic resource]. Hackensack, NJ : World Scientific.
- Brabazon, P. G., MacCarthy, B., Woodcock, A., & Hawkins, R. W. (2010). Mass Customization in the Automotive Industry: Comparing Interdealer Trading and Reconfiguration Flexibilities in Order Fulfillment. *Production and Operations Management*, 19(5), 489–502. <http://doi.org/10.1111/j.1937-5956.2010.01132.x>
- Brabazon, P. G., & MacCarthy, B. (2004). Virtual-Build-to-Order as a Mass Customization Order Fulfilment Model. *Concurrent Engineering*, 12(2), 155–165. <http://doi.org/10.1177/1063293X04044379>
- Brabazon, P. G., & MacCarthy, B. (2012). Investigating a long tail in retail vehicle sales. *Omega*, 40(3), 302–313. <http://doi.org/10.1016/j.omega.2011.07.005>
- Clemons, E. K., & Gao, G. (2008). Consumer informedness and diverse consumer purchasing behaviors: Traditional mass-market, trading down, and trading out into the long tail. *Electronic Commerce Research And Applications*, 7(Market transformation in a networked global economy), 3-17. doi:10.1016/j.elerap.2007.10.001
- Elias, S. (2002). *New Car Buyer Behaviour*. Retrieved from www.3daycar.com
- European vehicle inventory returns to bad old days. (2012). Retrieved from <http://automotivelogistics.media/data/european-vehicle-inventory-returns-to-bad-old-days>
- Franke, N., Schreier, M., & Kaiser, U. (2010). The “I Designed It Myself” Effect in Mass Customization. *Management Science*, 56(1), 125–140. <http://doi.org/10.1287/mnsc.1090.1077>
- Fredriksson, P., & Gadde, L. (2005). Flexibility and rigidity in customization and build-to-order production. *Industrial Marketing Management*, 34(IMP Conference, Rotterdam, 2004), 695-705. doi:10.1016/j.indmarman.2005.05.010
- Glasserman, P., & Yao, D. D. (1992). Some Guidelines and Guarantees for Common Random Numbers. *Management Science*, 38(6), 884–908. <http://doi.org/10.1287/mnsc.38.6.884>
- González-Benito, J., Lannelongue, G., & Alfaro-Tanco, J. A. (2013). Study of supply-chain management in the automotive industry: a bibliometric analysis. *International Journal Of Production Research*, 51(13), 3849-3863. doi:10.1080/00207543.2012.752586
- Gupta, A. K., & Nadarajah, S. (Eds.). (2004). *Handbook of Beta Distribution and Its Applications (Statistics: A Series of Textbooks and Monographs)*. CRC Press.
- Holweg, M. (2003). The three-day car challenge: Investigating the inhibitors of responsive order fulfilment in new vehicle supply systems. *International Journal of Logistics Research and Applications*, 6(3), 165–183. <http://doi.org/10.1080/1367556031000123106>
- Holweg, M., & Pil, F. K. (2004). *The second century : reconnecting customer and value chain through build-to-order : moving beyond mass and lean production in the auto industry*. Cambridge, Mass.; London : MIT.
- Holweg, M., Disney, S., Hines, P., & Naim, M. (2005). Towards responsive vehicle supply: a simulation-based investigation into automotive scheduling systems. *Journal of Operations Management*, 23(5), 507–530. <http://doi.org/10.1016/j.jom.2004.10.009>

- Jayaram, J., Vickery, S., & Droge, C. (2008). Relationship building, lean strategy and firm performance: an exploratory study in the automotive supplier industry. *International Journal Of Production Research*, 46(20), 5633-5649. doi:10.1080/00207540701429942
- Kessler, A. M. (2015). With car dealership's ranks thinned, the survivors thrive. *The New York Times*. <http://nyti.ms/1GuRBKH>
- Law, A. M., & Kelton, W. D. (2000). *Simulation modeling and analysis*. Boston: McGraw-Hill.
- Laurent Lim, L., Alpan, G., & Penz, B. (2014). Reconciling sales and operations management with distant suppliers in the automotive industry: A simulation approach. *International Journal Of Production Economics*, 15120-36. doi:10.1016/j.ijpe.2014.01.011
- Lockström, M., Schadel, J., Harrison, N., Moser, R., & Malhotra, M. K. (2010). Antecedents to supplier integration in the automotive industry: A multiple-case study of foreign subsidiaries in China. *Journal Of Operations Management*, 28(Culture, Development, and Operations Management Viewpoints in Asia), 240-256. doi:10.1016/j.jom.2009.11.004
- Matzke, A., Volling, T., & Spengler, T. S. (2016). Upgrade auctions in build-to-order manufacturing with loss-averse customers. *European Journal of Operational Research*, 250(2), 470-479. <http://doi.org/10.1016/j.ejor.2015.11.003>
- Meyr, H. (2004). Supply chain planning in the German automotive industry. *OR Spectrum*, 26(4), 447-470. doi:10.1007/s00291-004-0168-4
- Nakayama, M. K. (2007). Fixed-width multiple-comparison procedures using common random numbers for steady-state simulations. *European Journal of Operational Research*, 182(3), 1330-1349. <http://doi.org/10.1016/j.ejor.2006.09.045>
- New Car Delivery Times. (2016). Retrieved from <https://www.carwow.co.uk/new-car-delivery-times>
- Sanchez, S. M. (2008). Better than a Petaflop: the power of efficient experimental design. In S. J. Mason, R. R. Hill, L. Monch, O. Rose, T. Jefferson, & J. W. Fowler (Eds.), *Proceedings of the 2008 Winter Simulation Conference* (pp. 73-84). Retrieved from <http://www.informs-sim.org/wsc08papers/263.pdf>
- Sanchez, S. M. (2005). *NOLH designs spreadsheet*. <http://diana.cs.nps.navy.mil/SeedLab/>
- Stäblein, T., Holweg, M., & Miemczyk, J. (2011). Theoretical versus actual product variety: how much customisation do customers really demand? *International Journal of Operations & Production Management*, 31(3), 350-370. <http://doi.org/10.1108/01443571111111955>
- Staeblein, T., & Aoki, K. (2015). Planning and scheduling in the automotive industry: A comparison of industrial practice at German and Japanese makers. *International Journal of Production Economics*, 162, 258-272. <http://doi.org/10.1016/j.ijpe.2014.07.005>
- Tobin, D. (2014). Waiting times grow for most popular new cars. *The Sunday Times*. www.driving.co.uk/news/news-waiting-times-grow-for-most-popular-new-cars/
- Tomino, T., Park, Y., Hong, P., & Roh, J. J. (2009). Market flexible customizing system (MFCS) of Japanese vehicle manufacturers: An analysis of Toyota, Nissan and Mitsubishi. *International Journal of Production Economics*, 118(2), 375-386. <http://doi.org/10.1016/j.ijpe.2008.12.002>

- Turner, K., & Williams, G. (2005). Modelling complexity in the automotive industry supply chain. *Journal of Manufacturing Technology Management*, 16(4), 447–458. <http://doi.org/10.1108/17410380510594525>
- Van Utterbeeck, F., Wong, H., Van Oudheusden, D., & Cattrysse, D. (2009). The effects of resupply flexibility on the design of service parts supply systems. *Transportation Research Part E: Logistics and Transportation Review*, 45(1), 72–85. <http://doi.org/10.1016/j.tre.2008.04.002>
- Volling, T., Matzke, A., Grunewald, M., & Spengler, T. S. (2013). Planning of capacities and orders in build-to-order automobile production: A review. *European Journal of Operational Research*, 224(2), 240–260. <http://doi.org/10.1016/j.ejor.2012.07.034>
- Volling, T., & Spengler, T. S. (2011). Modeling and simulation of order-driven planning policies in build-to-order automobile production. *International Journal of Production Economics*, 131(1), 183–193. <http://doi.org/10.1016/j.ijpe.2011.01.008>
- Wernle, B. (2014). *Higher incentives lift Ford cars, trucks*. Retrieved from <http://www.autonews.com/article/20140801/RETAIL01/140809983/higher-incentives-lift-ford-cars-trucks>
- Williams, G., & Bozon, L. (2006). *Are we moving to customer pull?* International Car Distribution Programme Ltd, Solihull, UK.
- Williams, M. (2014). *Excess Inventory Costing Europe Millions*, Retrieved from <http://www.automotivelogisticsmagazine.com/news/excess-inventory-costing-europe-millions>
- WTO (2014). *World Trade Organization International Trade Statistics 2014*, available at www.wto.org/statistics Accessed 22/6/2015
- Wynstra, F., von Corswant, F., & Wetzels, M. (2010). In Chains? An Empirical Study of Antecedents of Supplier Product Development Activity in the Automotive Industry. *Journal Of Product Innovation Management*, 27(5), 625-639. doi:10.1111/j.1540-5885.2010.00741.x
- Young, A. (2014). *US New Auto Inventories Highest Since '09; GM, Volkswagen Top List; Kia, Hyundai Up Most; Toyota Stock At 'Healthiest' Level*. Retrieved from <http://www.ibtimes.com/us-new-auto-inventories-highest-09-gm-volkswagen-top-list-kia-hyundai-most-toyota-stock-healthiest>
- Zhang, X., Chen, R., & Ma, Y. (2007). An empirical examination of response time, product variety and firm performance. *International Journal of Production Research*, 45(14), 3135–3150. <http://doi.org/10.1080/00207540600786707>