

The Open University's repository of research publications and other research outputs

Negative ions formed in $N_2/CH_4/Ar$ discharge – a simulation of Titan's atmosphere chemistry

Journal Item

How to cite:

Horvath, G.; Aranda-Gonzalvo, Y.; Mason, N. J.; Zahoran, M. and Matejcik, S. (2010). Negative ions formed in $N_2/CH_4/Ar$ discharge – a simulation of Titan's atmosphere chemistry. *The European Physical Journal - Applied Physics*, 49(1) p. 13105.

For guidance on citations see [FAQs](#).

© 2009 EDP Sciences

Version: Version of Record

Link(s) to article on publisher's website:

<http://dx.doi.org/doi:10.1051/epjap/2009192>

Copyright and Moral Rights for the articles on this site are retained by the individual authors and/or other copyright owners. For more information on Open Research Online's data [policy](#) on reuse of materials please consult the policies page.

Negative ions formed in N₂/CH₄/Ar discharge – A simulation of Titan’s atmosphere chemistry

G. Horvath^{1,2,a}, Y. Aranda-Gonzalvo³, N.J. Mason², M. Zahoran¹, and S. Matejcek¹

¹ Department of Experimental Physics, Comenius University, Mlynska dolina F-2, 842 48 Bratislava, Slovakia

² Department of Physics and Astronomy, The Open University, Walton Hall, Milton Keynes MK7 6AA, UK

³ Plasma & Surface Analysis Division, Hiden Analytical Ltd., 420 Europa Boulevard, Warrington WA5 7UN, UK

Received: 30 June 2009 / Received in final form: 1st September 2009 / Accepted: 12 October 2009
Published online: 26 November 2009 – © EDP Sciences

Abstract. The formation of negative ions produced in a negative point-to-plane corona discharge fed by a Ar/N₂/CH₄ gas mixture has been studied using mass spectrometry. The measurements were carried out in flowing regime at ambient temperature and a reduced pressure of 460 mbar. The CN[−] anion has been found to be the most dominant negative ion in the discharge and is believed to be the precursor of heavier negative ions such as C₃N[−] and C₅N[−]. The most likely pathway for the formation of such molecular anions is H-loss dissociative electron attachment to HCN, H₃CN and H₅CN formed in the discharge. These same anions have been detected in Titan’s atmosphere and the present experiments may provide some novel insights into the chemical and physical mechanisms prevalent in Titan’s atmosphere and hence assist in the interpretation of results from the Cassini Huygens space mission.

PACS. 52.50.Dg Plasma sources – 52.80.Hc Glow; corona – 96.50.Dj Interplanetary dust and gas

1 Introduction

The recent Cassini space mission to Saturn and the release of its Huygens probe onto its largest moon, Titan, has led to a wealth of data on the atmospheric and surface composition of Titan, presenting us with a set of unexpected (and fascinating) results including the observation of hydrocarbon lakes – the first liquid “seas” on a solar system body outside the Earth; and the observation of anions in the upper atmosphere (ionosphere) [1]. Such results require laboratory simulations if we are to understand the physical and chemical processes that lead to such observed phenomena.

The dense atmosphere of Titan is mostly composed of N₂ with a few percent of CH₄. The most important minor compounds detected by Cassini Huygens are nitriles (HCN, HC₃N, HC₅N, C₂N₂) believed to be formed by as a result of dissociation of nitrogen and methane either by solar induced photolysis or by *electron impact* [2] and hydrocarbons (C₂H₂, C₂H₄, C₂H₆, C₃H₈, C₃H₄) [2]. The presence of clouds and strong convective motions are a particular feature of Titan’s lower atmosphere. Charged particles, originating from the Saturnian magnetosphere, can accumulate on droplets within the clouds of the troposphere. Neutralization of these charged particles leads

to corona discharges within the clouds which can induce chemical reactions in the troposphere [2].

There have been several theoretical models of Titan’s atmosphere which only considered three-body electron attachment to radicals or collisional charging of aerosols as a source of negatively charged species [3,4]. Probably because the first process is negligible at high altitude (densities lower than 10¹⁵ cm^{−3}) and because aerosols were not expected to be present above ~500 km, the presence of negative ions in Titan’s upper atmosphere had not postulated before the Cassini-Huygens mission. Therefore it came as a surprise when Cassini detected numerous negative ions in Titan’s upper atmosphere [5,6], observations that Vuitton et al. have sought to explain in a new model of the chemistry in Titan’s upper atmosphere [1,7]. However such models need to be tested against laboratory mimics.

In this paper we report the results of a new investigation of the formation of negatively charged products formed in a corona discharge fed by mixtures of methane, argon and nitrogen at 460 mbar.

2 Experimental set-up

The apparatus used in these experiments is shown schematically in Figure 1. A simple negative point-to-plane

^a e-mail: horeszka@gmail.com

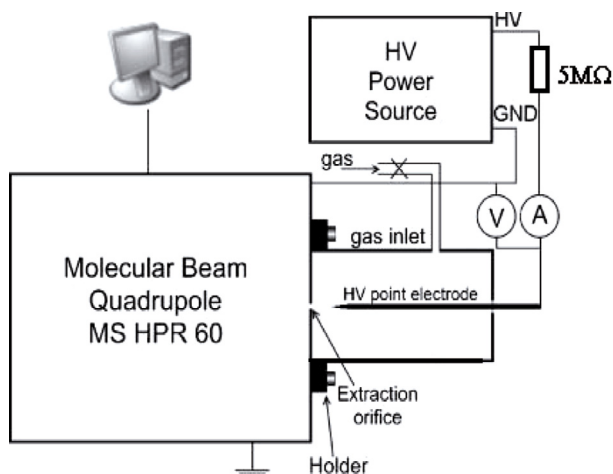

Fig. 1. A schematic diagram of the experimental apparatus used in the present experiments.

corona discharge was formed by using a stainless steel needle aligned opposite the sampling entrance of a HPR60 (Hiden Analytical Ltd.) molecular beam mass spectrometer (MBMS), [13]. The distance between the needle and the planar electrode was 8 mm. A voltage was applied between the needle (high voltage) and the entrance of the MBMS (ground electrode) creating a discharge with a constant volume of 80 cm³. Charged particles created in the discharge were sampled through the small sampling orifice (0.2 mm diameter) of the MBMS. The present experiments were performed using a N₂(88%)/Ar(8)/CH₄(4%) mixture at a reactor pressure of 460 mbar and ambient temperature, 20 °C. The presence of Ar in the mixture was for two reasons: it has also been detected in Titan's atmosphere and its plasma-cleaning properties increase the lifetime of the discharge which depends on the dust formed in the reactor. A mixing ratio was prepared and introduced into the reactor using MKS flow controllers. Measurements were carried out at flow rates of 100 and 200 ml/min. The point electrode was powered by a Spellman HV source whose output was measured using a HV probe combined with a digital multi-meter. The discharge current was measured using a Fluke milliamp-meter. A 5 MΩ resistor was connected in serial to the discharge in order to stabilize the corona discharge.

3 Experimental results and discussion

All the experiments were performed in a “quasi-flowing” regime with the gas mixture being introduced into the discharge chamber through a needle valve whilst the orifice into the mass spectrometer acted as the gas outlet. Mass spectra were recorded after allowing a suitable time for the discharge to stabilize. Stable conditions in the discharge were assumed when the relative yield of detected anions reached a constant value. The relative yield Y_r of ions having a mass per charge smaller than 100 amu was calculated from the measured absolute yield of ions i -type

in spectra Y_i by the formula

$$Y_r = \frac{Y_i}{\sum_i Y_i} \times 100 (\%).$$

Typical mass spectra of negative ions obtained at 0.8 mA for different flow rates (reactor pressure) are shown in Figure 2. The abundances of ions having mass more than 100 amu was negligible. Anion mass spectra have been measured for six selected discharge currents in range of 0.2 up to 0.8 mA. Seven dominant anions (masses 26, 40, 41, 41, 46, 50, 65) were observed in the spectra. In addition several unidentified (masses 64, 66 and 74) and unidentified negative ions (masses 79, 80, 82, 83, 91 and 92) were measured albeit with typical abundances 0.2–1.5%.

Identification of such unidentified negative ions will require some additional experiments so will not be discussed further. Most of the dominant ion peaks could be ascribed to monomers but one species has been found in cluster form as (CH₄).CH₄N⁻ (Fig. 3).

According to [1] negative ions are expected to be mostly deprotonated neutrals. For this reason we do not consider closed-shell molecules such as CH₃CN⁻, C₂H₂⁻ or HCN⁻ to be possible negative ion candidates. Another relevant thermodynamic constant is the gas phase acidity of the molecule AH, which characterizes the ability of the molecule to lose H⁺ by reactions



Species containing the cyano (CN, C₃N) or the ethynyl (C₂H, C₄H, C₆H, C₈H) group have a very high electron affinity (≥ 3 eV) [1]. As it can be seen in Figure 2, the detection of CN⁻, CH₂CN⁻, C₃N⁻, CH₂CN⁻ and C₅N⁻ anions provides good evidence of the presence of HCN, CH₃CN, HC₃N, CH₃CN and HC₅N neutrals that have already been detected by several authors and the Cassini flyby [1,8,9]. An important disagreement with Cassini's data and experimental measurements is that no hydrocarbon chain ions have been identified in our experiment. The absence of C_{2n}H⁻ in the spectra can be explained by relatively fast proton transfer reactions, leading to an increase in the yield of N-bearing ions and fast recombination of reactive C_{2n}H⁻ anions in the drift region of corona discharge:

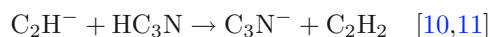

Thus the C₂H₂ neutral – detected in our earlier measurements made in coaxial corona discharge [12]- leads to the formation of CN⁻, C₃N⁻ and C₅N⁻ anions rather than C₂H⁻ production.

The formation of cluster anions in low-power discharges has been reported by several authors. The rapid decrease in abundance of anion at mass 46 with increasing power is a typical phenomenon of clustering where the higher electric field breaks up the weak Van der Waals bonds. The negative ion at mass 46 has therefore been identified as (CH₄).CH₄N⁻ anion.

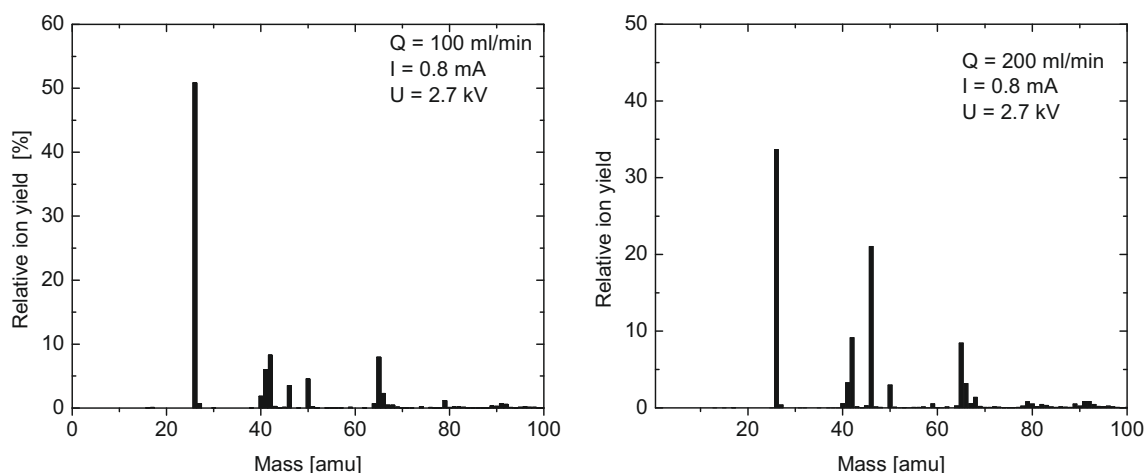

Fig. 2. Mass spectra of negative ions extracted from the discharges.

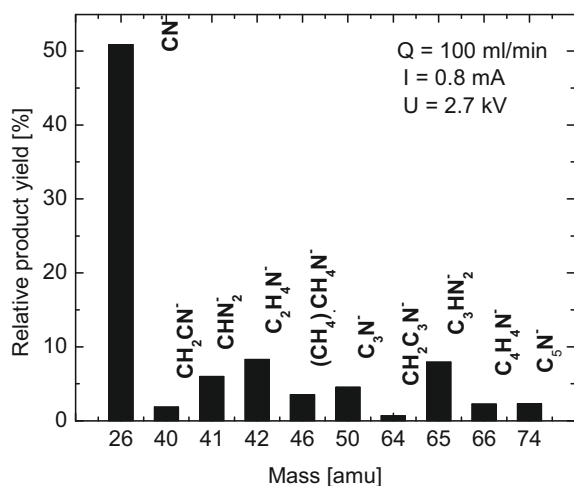

Fig. 3. Relative abundances of the most dominant anions formed in negative corona discharge.

Masses 41, 42, 65 and 66 have been tentatively identified as CHN_2^- , $\text{C}_2\text{H}_4\text{N}^-$, C_3HN_2^- and $\text{C}_4\text{H}_4\text{N}^-$ anions respectively but their origin needs further investigation.

4 Conclusion

The mass spectra of negative ions formed in a negative Ar/N₂/CH₄ corona discharge, operating at a pressure 460 mbar and room temperature, are very complex and have revealed many ionic species that have not been observed in previous studies. Detection of CN^- , CH_2CN^- , C_3N^- , CH_2CN^- and C_5N^- anions and the surprising absence of hydrocarbon radical anions have raised new questions about the dependence of negative ion chemistry on the discharge type.

This research project was supported by: The Slovak Grant Agency, Grant UK/381/2009, VEGA 1/0051/08, project SK-CN-0029-07, ESF COST Action CM0601, CM0805 and EIPAM.

References

1. V. Vuitton, P. Lavvas, R.V. Yelle, M. Galand, A. Wellbrock, G.R. Lewis, A.J. Coates, J.-E. Wahlund, *Planet. Space Sci.* (2009), doi:10.1016/j.pss.2009.07.014
2. S. Vinatier, 10 colleagues, *Icarus* **188**, 120 (2007)
3. G.J. Molina-Cuberos, J.J. López-Moreno, R. Rodrigo, *Geophys. Res. Lett.* **27**, 1351 (2000)
4. E.L.O. Bakes, C.P. McKay, C.W. Bauschlicher, *Icarus* **157**, 464 (2002)
5. A.J. Coates, F.J. Crary, G.R. Lewis, D.T. Young, J.H. Waite, E.C. Sittler, *Geophys. Res. Lett.* **34**, L22103 (2007)
6. J.H. Waite, D.T. Young, T.E. Cravens, A.J. Coates, F.J. Crary, B. Magee, J. Westlake, *Science* **316**, 870 (2007)
7. V. Vuitton, R.V. Yelle, P. Lavvas, *Phil. Trans. R. Soc. A* **367**, 729 (2009)
8. A. Ricard, G. Cernogora, M. Fitaire, L. Hochard, N. Kouassi, C. Speller, J.R. Vacher, *Planet. Space Sci.* **43**, 41 (1995)
9. R. Navarro-Gonzalez, S.I. Ramirez, *Adv. Space Res.* **19**, 1121 (1997)
10. G.I. Mackay, L.D. Betowski, J.D. Payzant, H.I. Schiff, D.K. Bohme, *J. Phys. Chem.* **80**, 2919 (1976)
11. C. Barckholtz, T.P. Snow, V.M. Bierbaum, *Astrophys. J.* **547**, L171 (2001)
12. G. Horvath, J.D. Skalny, N.J. Mason, M. Zahoran, *Plasma Sources Sci. Technol.* **18** (2009)
13. Y.A. Gonzalvo, T.D. Whitemore, C.L. Greenwood, J.A. Rees, L.V. Ratcliffe, D.A. Barrett, F.J.M. Rutten, M.R.S. McCoustra, *J. Vac. Sci. Technol. A* **23**, 550 (2006)