



Open Research Online

The Open University's repository of research publications and other research outputs

The development of automatic control in France

Journal Item

How to cite:

Remaud, P. and Bissell, C. (2009). The development of automatic control in France. IEEE Control Systems Magazine, 29(2) pp. 108–114.

For guidance on citations see [FAQs](#).

© 2009 Unknown

Version: [\[not recorded\]](#)

Link(s) to article on publisher's website:

<http://dx.doi.org/doi:10.1109/MCS.2008.931721>

Copyright and Moral Rights for the articles on this site are retained by the individual authors and/or other copyright owners. For more information on Open Research Online's data [policy](#) on reuse of materials please consult the policies page.

oro.open.ac.uk

The Development of Automatic Control in France

PATRICE REMAUD and CHRIS BISSELL

Nineteenth-century French scientists, mathematicians, and engineers made enormous contributions to the study of dynamics, including analyses of governors and regulators, which we now view as important precursors of the modern discipline of automatic control. By the late 1930s at least some French engineers were aware of the advances in the analysis of feedback that had been made by Black and Nyquist in the United States in the preceding decade. Yet, during the Second World War, France found itself isolated, and neither the occupied zone nor Vichy offered a conducive environment for the sort of R&D that was taking place not only in the United States and the United Kingdom, but also in Germany and the USSR, and that led to the discipline of classical control. Immediately after the war, though, a great deal of French activity took place in promulgating the new ideas. By 1956, a year that saw several major international conferences, as well as the proposal to form the International Federation of Automatic Control (IFAC), France had become a major player.

A detailed survey of the history of automatic control in France appears as [1], which provides extensive bibliographic information. This article aims to introduce this aspect of the development of automatic control to a wide readership.

CONTROL ENGINEERING IN FRANCE BEFORE 1945

During the course of the 19th century, the problem of governing the motion of prime movers was addressed in many countries. A major problem was the design of a stable isochronous governor, that is, one without steady-state error, and thus with some type of integral action. Among major contributors in France to this problem were Jean Bernard Léon Foucault, Jean Victor Poncelet, Henri Léauté, Léon Lecornu, and the father and son collaborators Marie Joseph and Jean Joseph Léon Farcot. Jean Joseph Farcot went on to design and patent a ship-steering engine and published probably the first book on servomotors in 1873, which was also the first account of the general principles of position control [2]. Figure 1 shows one of the Farcot devices.

In France, with its tradition of prestigious engineering schools, regulation soon became part of the mechanical

engineering curriculum. Poncelet, professor at both the University of Paris and the School of Engineering and Artillery, published his *Treatise of Mechanics Applied to Machines* in 1856, in which he considered explicitly, as he put it, “the principal means of regulating the action of forces on machines, and of ensuring uniform motion.”

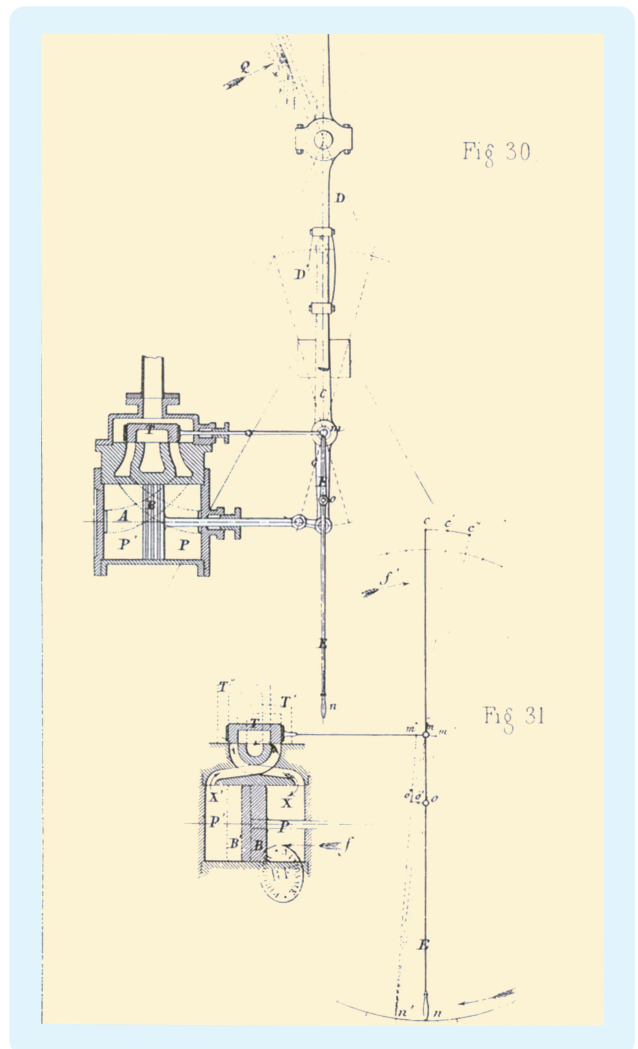

FIGURE 1 Farcot's servomotor. The Farcot father-and-son team was a major contributor to the development of ship steering engines and servomotors in the 19th century. The term “servomotor” (literally, “slave motor”) appears to have resulted from this work.

Other notable publications were Résal's *Treatise on General Mechanics* in 1875 and, most important of all, Lecornu's *The Regulation of Steam Engines*, published in 1904. This latter book not only covered the construction and performance of governors but also discussed various theoretical analyses, including Vyshnegradskii's stability analysis of a third-order system and Léauté's study of long-period oscillations.

From the 1880s onward, the development of industrial electrical applications led to the need for advanced training of engineers, and in 1894 the *École Supérieure de l'Electricité* was founded in Paris. The topic of regulation soon became extremely important. Not only, for example, did hydraulic turbines have to maintain a carefully controlled speed, but also voltage and current needed to be regulated. In 1896 Marcel Deprez at the Conservatoire National des Arts et Metiers (CNAM) published his *Theoretical and Practical Treatise of Industrial Electricity*, in which he addressed these topics. Similarly, Louis Barbillion of the Grenoble Electrical Engineering Institute published a textbook in 1911 in which he reviewed the previous half century of work on regulation, including direct and indirect governors, compensation, Farcot's servomotor, and the simultaneous control of speed and voltage [3]. He exploited the graphical techniques of the late 19th century, including those of Léauté, which he improved to some extent. Additional courses in higher engineering education were offered, resulting in modest improvements in technique but not in any significant theory, for example, on modeling or stability criteria.

As described in [2] and [4], the 1920s and 1930s saw fundamental advances in communications engineering and servo design. This work, developed initially for transcontinental telephony and differential analyzers, respectively, would later be generalized to all types of control. Carried out predominantly in the United States, but with significant development in the United Kingdom, Germany, and the USSR, this work appears not to have been widely known in France. With the outbreak of the Second World War, most French researchers moved to the nonoccupied zone (Vichy) or left the country to contribute to the allied war effort.

The first French publications mentioning the work of Black and Nyquist appeared toward the end of the 1930s [5], [6]. These publications, however, did not generalize the Nyquist criterion to areas outside feedback amplifiers; neither do these early articles seem to be cited later. Immediately after the war, however, France saw a veritable explosion of information about new approaches to control engineering, when French engineers and academics were exposed to the enormous developments that had taken place during the hostilities.

CNAM LECTURES MAY 1945

Given the isolation of France during the war, it seems surprising at first that as early as April 1945 a set of lectures was delivered at the Conservatoire National des Arts et

TABLE 1 The lectures at the Conservatoire, 1945, the first on control delivered in post-war France, although they did not include the most recent war-time developments [7].

Date	Author	Title
5 April	M. Véron V. Broïda	"Introduction" "Regulation and the Inertia Problem"
12 April	V. Broïda	"General Mechanism of Automatic Control"
19 April	L. Orengo	"Electrical Controllers and Their Application to Domestic Heating"
26 April	A. Liébaud	"Automatic Control of Steam Boilers"
3 May	M. Desmaroux	"Hydraulic and Pneumatic Controllers and Their Industrial Applications"
17 May	J. Clain	"Pyrometry and Electrical Furnace Control"
24 May	M. Le Blanc	"High Precision Automatic Control: Some Current Work"

Metiers on automatic thermal regulation, as listed in Table 1. Given the shortage of both labor and fuel at the time, it made a great deal of sense to look at technological ways of improving productivity and efficiency. There was also a need to educate the public. Marcel Véron, the organizer of these lectures, wrote that it was necessary to engage the public and the users and to raise awareness of the dangers of not properly matching the control to the system. According to Véron, technical terminology was also a problem, as he pointed out in his introductory speech. The French vocabulary of control, derived to some degree by literal translation of foreign expressions, led to confusion, obscurity, and misunderstanding and did not assist in the uptake of the new techniques. The technical terminology of control engineering in France, as in other countries, was to remain problematic for a number of years.

None of these lectures, with the possible exception of that by Le Blanc on high-precision control (see Table 1), who included the Nyquist criterion, presented any of the new techniques that had emerged from the war. But it is remarkable that the series was presented at all. Several of the lectures were published in the journal *Mesures. Essais. Régulation. Contrôle Industriel* from May 1945 onward. It is worth looking in a little more detail at the talks given by Broïda and Le Blanc.

Victor Broïda (Figure 2) was born in 1907 in Moscow. He was educated in France, held several senior academic posts, and was influential in establishing both the French Association of Control and Automation (AFRA) and IFAC. His two lectures in 1945 were wide ranging, covering social aspects as well as technical. He noted that automation of manufacturing processes, and the

ways of achieving it, had all too often been considered only as a means of reducing or eliminating workers, and hence reducing the price of manufactured goods. But like many others of the time, he also claimed benefits for the new technologies, given appropriate management. The technical parts of his presentations did not add much new, relying on standard differential equation models.

Le Blanc's lecture is particularly interesting since it includes a discussion of Nyquist's work. He was perhaps the first to speak on this topic in France to an audience other than telecommunications engineers. He remarks that "this [frequency response] analysis is encapsulated in the *Nyquist criterion*, well known to radio engineers. Nyquist's work, relatively recent, was needed in particular for the use of high-gain, wide bandwidth amplifiers for multiplexed cable telephony. These amplifiers have their gain held constant by means of negative feedback. So, it was indeed the general problem of automatic control that Nyquist was studying ..."

August 1945 was also marked by another interesting publication in *Mesures. Essais. Régulation. Contrôle Industriel*. A 15-page bibliography on automatic control covers work from the 19th and early 20th centuries in France and other countries, yet it is practically silent on the groundbreaking work of the previous decade [8]. Another two years were needed for the work of the late 1930s and 1940s to become widely known in France.

1947: THE LONDON CONFERENCE

In May 1947 the British Institution of Electrical Engineers and the Ministry of Supply jointly organized the Conference on Automatic Regulators and Servomechanisms. The conference, attended mainly by British participants but with a French delegation and American and Soviet observers, was aimed at promulgating the new classical control (frequency-domain) techniques beyond the application areas, particularly gun fire control, for which these techniques had been developed during the war.

The French delegation consisted of Gérard Lehmann, Julien Loeb, Pierre Naslin, and de Moreau, who were all active in either research, development, or teaching in French institutions. As a result of their visit to London, Lehmann, Loeb, and Naslin wrote influential articles in *L'Onde Electrique* in 1948 [9]–[11].

Lehmann noted that the term "servomechanism" was not widely understood in France at the time. He stressed the importance of servos for both military and industrial applications and noted the power of harmonic

analysis: "In addition to the standard methods of system dynamics, such as differential equations, we are increasingly using analytical tools familiar to radio engineers: Fourier transformation; sinusoidal response; use of complex variables; symbolic calculus and graphical representations in the complex plane. In this way Nyquist's approach for negative feedback amplifiers has been extended to servo systems [...]. The most significant difference between radio and servomechanism applications is that the latter concern 'hyper-low' frequencies. [...] It is difficult to rid ourselves of mental conceptions that lead us to limit radio engineering methods to high-frequency applications. [...] We are not accustomed to envisaging sinusoidal phenomena with periods of the order of minutes or even hours."

Loeb gave a summary of the work of the conference as a whole, including civil and military applications; gun control and automatic radar detection; voltage regulation; speed, temperature, and pH control; and machine tool profiling.

According to Lehmann, the conference was just a first step: "One of the most notable features of this conference has been an attempt by engineers familiar with radio engineering to persuade their colleagues of the elegance and effectiveness of methods based on harmonic analysis [but] it would be an exaggeration to say that this initiative has been a complete success. One can hardly expect engineers, who have perfected their own research instruments and who have obtained tangible results, to discard them from one day to the next in favor of new methods. From this point of view the conference has been a matter of initiating contact rather than unifying."

The French attendance at the 1947 London conference, and the resulting publications in *L'Onde Electrique*, were an important stage in the dissemination of classical control ideas in France. But the acceptance of the novel approach in industrial process control occurred slowly, and with some difficulty and controversy, needing until the 1960s to become firmly established.

CNAM LECTURES OCTOBER/NOVEMBER 1947

Another important series of lectures, this time on the state of the art of servomechanisms, was held at the *Conservatoire* in late 1947, organized in collaboration with several other institutions. The lectures, of the greatest significance for the development of automatic control in France, were published in two volumes in 1949 [12], as outlined in Table 2.



FIGURE 2 Victor Broïda. Of Russian origin, Victor Broïda was one of the most significant figures in French post-war control engineering, and went on to be one of two first vice-presidents of IFAC. (From *Automatisme*, p. 166, May 1956.)

By this time the French were beginning to feel more self-confident after their wartime experiences. In the preface to these lectures, Albert Métral notes the need to contest “the opinion that French science and technology in these times must bow to foreign science and technology.” Despite the recent difficulties, Métral claimed that French brainpower was as good as ever and that French science and engineering would again be the envy of the world. Nevertheless, it is worth noting how much ground had to be made up by the French. As mentioned above, Lehmann and Loeb had attended the London conference and were well aware of the gap; Raymond had made a study trip to the United States in 1946, with similar results.

The 1947 lectures and the ensuing publication [12] gave a good indication of the state of the art in the immediate aftermath of the war, covering the properties of closed-loop systems, block diagrams, servos in analog computers, the work of Nyquist and Bode, fire control, radar, and naval and aeronautical applications.

TEACHING THE NEW DISCIPLINE

Widespread teaching of the new discipline was slow to take root in French universities and engineering schools. However, as early as 1945 Pierre Nicolau introduced a course on servosystems at the National School of Armaments, of which he was the director. In 1948 he was tasked with establishing a Higher Institute of Materials and Mechanical Engineering, with the aim of ensuring advanced level education for engineers in the civilian sector, as had already been done for the military. The course in the latter institute, delivered by Naslin (Figure 3) and two colleagues, comprised a total of 25 90-minute lectures/seminars along with 15 three-hour laboratory classes. The structure of Naslin’s contribution, including theory and mathematics, was described in 1956 as follows:

- » “Notion of a Servosystem: Simple Examples”
- » “Fundamental Properties of Linear Electromechanical Systems: Transfer Functions, Examples, dc Motor, Ward-Leonard”
- » “Fundamental Equations of Linear Servosystems”
- » “Graphical Representation of Transfer Functions: Gain/Phase Curves, Black [Nichols] Diagram”
- » “Stability of Linear Servosystems”
- » “Accuracy of Linear Servosystems”
- » “Electrical and Mechanical Compensators, Forward and Feedback Paths”



FIGURE 3 Pierre Naslin. Naslin wrote some of the most influential papers and texts on servomechanisms in post-war France, and was one of the country’s most gifted university teachers in the field. He was one of four French delegates at the London servo conference in 1947. (From *Automatisme*, p. 207, June 1956.)

- » “Theory of Filtered Nonlinear Systems: Application to Nonlinear Servosystems”
- » “Application of Servosystems to Experimental Mathematics: Analog Computers, Simulators”
- » “Multivariable Systems: Differential Analysers, Machine Tools.”

Naslin, in fact, became one of the most significant figures in French postwar control engineering, authoring a series of influential articles and books throughout the 1950s [13], [14].

Another center of excellence was the Centre de Perfectionnement Technique, which offered courses in advanced technologies to qualified engineers. The center sponsored two series of lectures in 1955 and 1956 on control and instrumentation, covering electronics, hydraulics, heat engineering, chemical engineering, and their associated regulation techniques. Similarly, in 1956 the Conservatoire National des Arts et Metiers offered a two-year professional development program including a wide range of lectures and 15 practical sessions. This program was another significant contribution from Victor Broïda, who was the course director.

Broïda also introduced control engineering to the University of Charleroi in the French-speaking part of Belgium, a course that was based on his 1957 text *Automation, Automatic Control, Servomechanisms* [15]. It was particularly significant that Broïda came from the process engineering sector, since this background enabled him to understand the particular difficulties encountered by engineers without an electronics or telecommunications background when engaging with the novel ideas of classical control. In his 1955 article [16] he noted the need to introduce

sometimes fairly complex ideas, such as harmonic analysis or symbolic calculus, branches of mathematics of which the majority of control engineers have only a superficial understanding [...]

Furthermore,

this science of automation has long been accessible—and continues to be so—predominantly to physicists and mathematicians, amongst whom are rarely to be found those who could profit the most from the practical point of view (namely, the technicians involved in automatic control). Within the automatic control community only the specialists in servomechanisms, by virtue of the very nature of their area of interest, are

TABLE 2 The contents of *Analysis, Synthesis, and Current State of the Servomechanism Question* [12]. These two volumes were the result of the 1947 lecture series at the Conservatoire.

Volume 1	Author	Title
Preface	A. Métral	
Chapter I	F.-H. Raymond	“Overview of the Principles of Servomechanisms”
Chapter II	G. Lehmann	“Theory, Accuracy and Stability of Servomechanisms”
Chapter III	F.-H. Raymond	“Servomechanisms in Experimental Mathematics”
Chapter IV	F.-H. Raymond	“Servomechanisms in Firing Problems”
Volume 2		
Chapter I	G. Lehmann	“Servomechanisms in Radar Equipment”
Chapter II	J. Loeb	“Servomechanisms Incorporating a Radio Link”
Chapter III	P. Colombani	“Servomechanisms at the Heart of Modern Aeronautics”
Chapter IV	A. Pommelet	“Servomechanisms In Naval Technology”

relatively familiar with the theoretical basis of automatic control. [...]

The daily increase in applications of automation in industry requires urgently that the teaching of the topic must not be done in a fragmentary manner. Integrated teaching of automation and automatic control seems therefore vital for the steady development of the sector.

Broïda also conducted a survey of the teaching of control in France and abroad, receiving about a dozen French responses and about the same number from foreign institutes. He found that the discipline was still generally dispersed over the traditional branches of engineering; few institutes of higher education offered an all-encompassing, generic approach. He concluded that the United States, Germany, and Belgium were the most advanced in this respect, with one or two centers of excellence in France and the United Kingdom. One of the problems for France was that, apart from a few exceptions, the necessary mathematics for classical control was not taught in engineering schools, and thus many of the courses in control that did exist could not exploit the full power of the new discipline. By the mid-1950s, however, the French Ministry of Education was beginning to wake up to the potential of control engineering, and several chairs were created in French universities.

1956: A TURNING POINT

The year 1956 saw a remarkable sequence of events that established the discipline much more strongly in France. In January of that year the journal *Automatisme* was founded as the first specialist publication in the field. Earlier articles on automatic control had appeared in *Mesures. Essais. Régulation. Contrôle Industriel, L'Onde Electrique, La Revue Générale de Electricité*, and *Les Annales des PTT*. All of these journals, however, had a much wider remit and could hardly satisfy the need for scientific publication in the new field. The title of the journal is interesting, namely, *Automatisme* rather than *Automatique* as might have been expected. The distinction between the two terms is rather difficult to render precisely in English; together they cover most aspects of English “automation” and “automatic control,” but the choice of title, and the discussion of terminology in the first issue, illustrates the terminological confusion at the time in France. It is worth noting in this context that in the English-speaking world similar terminological difficulties had been addressed in the late 1940s and were more or less resolved by the mid-1950s.

The editorial committee included many of the most prestigious names in automatic control in France at that time, namely, Maurice Lachin (editor in chief), supported by Victor Broïda, Léon Chevillotte, Félix Esclangon, Pierre Naslin, Pierre Nicolau, Auguste Pommier, François-Henri Raymond, Roger Robert, Pierre Schnerb, Maurice Surdin, and Uri Zelbstein. Of those already mentioned in this article so far can be counted Broïda, Naslin, Raymond, and Nicolau. The educational background of the committee is interesting. Six had studied at highly prestigious and academic engineering schools, three at more applied engineering schools, and three included university study. Seven of the committee were academics and four were from industry. Sectors represented included transport, production, electricity generation and distribution, the nuclear industry, aviation, and the military.

The founding of *Automatisme* was closely followed by the establishment of the Association Française de Régulation et Automatisme (AFRA) in May 1956. Again, many of the same individuals were involved, with Pierre Nicolau as honorary president, Marcel Véron as president (also editor in chief of *Automatisme* until succeeded by Naslin in 1958), and Broïda as vice president. The association had ambitious plans, including

- » lectures, conferences, meetings, and exhibitions
- » reports, standardization, publications, films
- » infrastructure support, if possible the creation of laboratories and documentation centers
- » a regional structure bringing together technicians, engineers, and industrialists
- » maintaining close links with other relevant bodies at home and abroad.

Specialized conferences in the new discipline came thick and fast in the mid 1950s; for example, Margate, England in

1955 was followed by Milan, Italy, in April 1956 and then Paris in June of the same year.

The Paris International Conference on Automatic Control (Figure 4) assembled about a thousand participants from Monday to Sunday, June 18–24 [17]. The conference chair was François-Henri Raymond; remarkably, the two vice-chairs of the organizing committee were J.F. Coales, professor at Cambridge University, and D.P. Campbell from MIT, which illustrates the international nature of the event. The conference was oriented toward practical applications. According to Raymond,

It is thus essential that an international conference should make a preliminary evaluation of the scientific methods available to researchers in the field of automation, and draw up an inventory of possible techniques [...] The mission of the conference, amongst others, will be to evaluate the fun-

damental theories of this new science of theoretical and applied automatic control – which should not be confused with cybernetics [...] The conference will provide a forum for reviewing application areas in industrial production, office automation, and planning techniques. Finally, by appealing to operations research (OR) specialists, the conference will also demonstrate the complementary nature of OR and automation in scientific management.

The conference was organized into three sections: general automatic control, applied automatic control, and automatic control and production. One way that interdisciplinarity was encouraged was for a one-hour general presentation to be followed by three 30-minute papers from mechanical, electrical, and chemical engineers and then general discussion. Extensive extracts from conference papers appeared in the July and August issues of *Automatisme*. Participants came from the United Kingdom, United States, Italy, Sweden, and Yugoslavia, as well as France, ensuring an international character. But the renewed self-confidence of the French is reflected in phrases such as “a French approach to automation” or a distinctively “French automatic control” that could be heard at

the time (and which were echoed in other disciplines during the postwar reconstruction of the country).

Another example of the increasing internationalization of the French control community was the appearance in 1956 of *Théorie et Technique des Asservissements*, by J-C Gille, M.J. Pelegrin, and P. Decaulne [18]. Born in Trier, Germany, and a polymath who later embraced medicine, psychiatry, and graphology (the study of handwriting) as

well as engineering, Gille was a gifted linguist who studied at the École Polytechnique, the École Nationale Supérieure de l’Aéronautique, and Harvard, later becoming a professor at Laval University in Canada. The book includes dynamics, linear servos, nonlinear servos, components, and design. The book also contains a five-language glossary of automatic-control terms in English, Spanish, French, German, and Russian, notes on the differences of block diagrams and stability analysis in the



FIGURE 4 The Paris conference. It can be argued that this event, above all, left no doubt that France was now a major player in the control engineering field. Attracting delegates from many countries, its organizing committee included Donald Campbell from MIT and John Coales from Cambridge University. (From *Automatisme*, pp. 252–253, July 1956.)

German and Russian literature (which were so different from the standard British and American conventions at the time that they were a real barrier to understanding), as well as a discussion of the important literature in English, French, German, and Russian. The book was highly influential in France, and also appeared in English, German, Russian, Spanish, and Polish.

But perhaps the greatest turning point of 1956 was the Heidelberg conference in September of that year, which arguably enjoyed the most varied and distinguished participation of all the control conferences of the mid 1950s. At this meeting, a group of delegates agreed to form an international association. The resulting IFAC was officially established in Paris, in September 1957. It is indicative of Cold War reality, and the enormous strides made by the French over the previous decade, that the first IFAC president was the distinguished American control engineer Harold Chestnut and that the two vice presidents were not only the Russian A.M. Letov, but also our old friend Victor Broïda! In just over ten years following the end of the Second World War, French control engineering had transformed itself from an essentially prewar approach into a discipline well informed about

international developments, and a leading player in international professional activities.

AUTHOR INFORMATION

Patrice Remaud (patrice.remaud@univ-poitiers.fr) is an associate professor at the University of Poitiers, France, where he teaches control engineering and signal processing. His research is on the history of automatic control in France as well as the history of science and technology, and he recently gave a series of lectures in Eastern Europe on historical topics. He can be contacted at Laboratoire d'Automatique et d'Informatique Industrielle, École Supérieure d'Ingénieurs de Poitiers, 40 avenue du Recteur Pineau, 86022 POITIERS France.

Chris Bissell (c.c.bissell@open.ac.uk) is professor of telematics at the U.K. Open University. He has written distance teaching materials on control engineering, telecommunications, information technology, signal processing, and media studies. His research interests are in the history of technology and engineering education. He can be contacted at the Faculty of Mathematics, Computing & Technology, Open University, Milton Keynes, MK7 6AA, U.K.

REFERENCES

- [1] P. Remaud, *Histoire de l'Automatique en France 1850–1950* (Transl.: History of Automatic Control in France 1850–1950). Paris: Hermes Lavoisier, 2007.
- [2] S. Bennett, *A History of Control Engineering 1930–1955*. Stevenage, U.K.: Peter Peregrinus, 1993.
- [3] L. Barbillion, *Cours Municipal d'Electricité Industrielle* (Transl.: Course in Industrial Electricity). Paris: Geisler, 1911.
- [4] D. Mindell, *Between Human and Machine*. Baltimore: Johns Hopkins Univ. Press, 2002.
- [5] L. Chrétien, "Amplificateurs à contre-réaction (Transl.: Feedback amplifiers)," *L'Onde Electrique*, vol. 193, pp. 5–21; vol. 194, pp. 81–99, Jan./Feb. 1938.
- [6] F. Bedeau and J. de Mare, "Etude des principes de la rétroaction (Transl.: A study of the principles of feedback)," *L'Onde Electrique*, vol. 196, pp. 153–173; vol. 197, pp. 247–270, Apr./May 1938.
- [7] M. Véron, "La régulation thermique automatique. Introduction (Transl.: Automatic thermal regulation. Introduction)," *Mesures. Essais. Régulation Contrôle Industriel*, vol. 96, pp. 353–354, May 1945.
- [8] Anon, "Répertoire bibliographique relatif à la régulation automatique (Transl.: Bibliography of automatic control)," *Mesures. Essais. Régulation Contrôle Industriel*, vol. 99, pp. 465–471, Aug. 1945.
- [9] G. Lehmann, "Les servomécanismes en liaison avec les problèmes de radioélectricité (Transl.: Servomechanisms in connection with radio engineering problems)," *L'Onde Electrique*, vol. 255, pp. 213–217, June 1948.
- [10] J. Loeb, "Le congrès des servomécanismes (Transl.: The servomechanisms conference)," *L'Onde Electrique*, vol. 256, pp. 275–277, July 1948.
- [11] P. Naslin, "Quelques points particulièrement intéressants développés au congrès sur les servomécanismes (Transl.: Some particularly interesting topics from the servomechanisms conference)," *L'Onde Electrique*, vol. 260, pp. 445–454, Nov. 1948.
- [12] P. Colombani, et al., *Analyse, Synthèse et Position Actuelle de la Question des Servomécanismes* (Transl.: Analysis, Synthesis and Current State of the Servomechanism Question). Paris: Société d'Édition d'Enseignement Supérieur, 1949.
- [13] P. Naslin, *Les Systèmes Asservis* (Transl.: Servosystems). Paris: Dunod, 1951.
- [14] The series of tutorial articles. *Automatisme*, Mar., Apr., June, July, Nov., Dec., 1956 and Feb. 1957.
- [15] V. Broïda, *Automatisme. Régulation Automatique. Servomécanismes*. Paris: Dunod, 1957.
- [16] V. Broïda, "La situation actuelle de l'enseignement de l'automatisme et de la régulation automatique en France et à l'étranger (Transl.: The current situation in the teaching of automation and automatic control in France and abroad)," *Mesures. Essais. Régulation. Contrôle Industriel*, vol. 214, pp. 171–178, 1955.
- [17] Anon, "Le congrès international de l'automatisme de Paris (June 18–24, 1956)," *Automatisme*, vol. 7, pp. 252–257, 1956.
- [18] J.-C. Gille, M. J. Pelegrin, and P. Decaulne, *Théorie et Technique des Asservissements*. Paris: Dunod, 1956 (Published in English as: *Feedback Control Systems: Analysis, Synthesis, and Design*. New York: McGraw-Hill, 1959).



Fully Productive

For the next few months, work, his oldest friend, once again became his steady companion. Frank Marble wrote to Kármán to tell him that Tsien was resigned to the fact that his case would not be resolved soon, and that while he was not really happy, he now had more peace of mind. Tsien tackled a wide variety of topics: linear systems with time lag, transfer functions of rocket nozzles, automatic guidance of long-range rocket vehicles, properties of pure liquid, take-off from satellite orbit, a similarity law for stressing rapidly heated thin-walled cylinders. He turned out a scientific paper once a month for four consecutive months—an outstanding achievement in his field.

—*Thread of the Silkworm*, by Iris Chang,
BasicBooks, New York, 1994, p. 173.