



# Open Research Online

---

The Open University's repository of research publications and other research outputs

## Historical perspectives - The Moniac A Hydromechanical Analog Computer of the 1950s

### Journal Item

How to cite:

Bissell, C. C. (2007). Historical perspectives - The Moniac A Hydromechanical Analog Computer of the 1950s. IEEE Control Systems Magazine, 27(1) pp. 59–64.

For guidance on citations see [FAQs](#).

© [not recorded]

Version: [not recorded]

Link(s) to article on publisher's website:

<http://dx.doi.org/doi:10.1109/MCS.2007.284511>

---

Copyright and Moral Rights for the articles on this site are retained by the individual authors and/or other copyright owners. For more information on Open Research Online's data [policy](#) on reuse of materials please consult the policies page.

---

[oro.open.ac.uk](http://oro.open.ac.uk)

## The Moniac

### A Hydromechanical Analog Computer of the 1950s

CHRIS BISSELL

Once upon a time there was a student at the London School of Economics [...] who got into difficulties [...] with such questions as whether Savings are necessarily equal to Investment [...] but he realised that monetary flows and stocks of money could be thought of as tankfuls of water ... Prof. James Meade (later Nobel Laureate for Economics), 1951 [1]

The odd-looking machine is an ingenious hydraulic device that teaches economical principles in a few easy and graphic operations. It was invented by a New Zealand electrical engineer named A. W. Phillips, and dubbed the 'Moniac' by its initial US enthusiast, economist A. P. Lerner [...] to suggest "money, the ENIAC and something maniacal. *Fortune Magazine*, 1952 [2]

Most analog computers, as *IEEE Control Systems Magazine* readers are reminded by the June 2005 special section, were firmly based on mechanical or electrical principles. The 'Moniac,' or Phillips Machine as it is more commonly known (figures 1 and 2), was different. An analog simulator of a national economy, the Moniac used the flow of colored water to represent the dynamics of the flow of money. Its creation was a result of the inspired collaboration between the electrical-engineer-turned-economist A.W.H. (Bill) Phillips and his economist colleague Walter Newlyn.

Phillips was born in New Zealand in 1914 and as a young man traveled through Australia, China, and Russia,

reaching England just before the outbreak of World War II. He spent three and a half years in Japanese POW camps, where, under an ever-present threat of execution, he managed to construct, hide, and maintain a radio receiver. After the war he returned to London to study sociology as a mature undergraduate at the London School of Economics (LSE). Becoming disillusioned by sociology but fascinated by economics, he stayed on to do graduate work in the latter area. As an undergraduate, he managed only a pass degree in sociology, attributed to his chain-smoking habit, which detracted from his perfor-

mance in three-hour examinations. Nevertheless, Phillips subsequently rose to full professor in economics in less than a decade. He died in 1975, and his work was celebrated a quarter of a century later in a collected edition [3], which includes all of his published papers, together with several unpublished ones. The volume also includes commentaries by contemporaries and others, as well as a detailed historical assessment.

This article aims to bring wider attention to his "ingenious computational device [and] inspired piece of pedagogy" [4], while emphasizing the relationship between his work and control engineering.

#### THE ORIGINS OF THE MACHINE

The hydraulic simulator became a reality as a result of a conversation between Bill Phillips and fellow economist Walter Newlyn in 1949. Newlyn, born in 1915, had left school without qualifications, but, after part-time self-study and army service in France and India, was admitted to the LSE a year before Phillips, where they became close friends. In 1949 Newlyn had just taken up a junior academic post at Leeds University. He later became a distinguished monetary theorist, held a number of important posts in Africa, and was chair of development economics at Leeds University from 1967 to 1978.

While the notion of representing the flow of money in an economy by the flow of water was not new, Phillips wrote a draft paper outlining how a physical device could actually be built. At the heart of such a device would be the hydraulic system shown in Figure 3, where the upper pipe represents the flow to the market, while

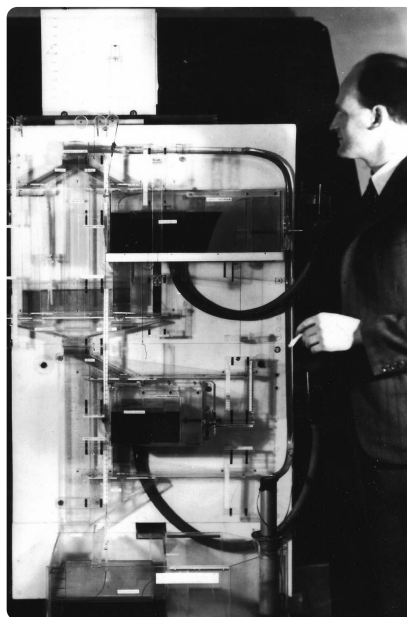

**FIGURE 1** Bill Phillips and the prototype machine. Phillips demonstrated the machine at a 1949 London School of Economics Seminar, during which he gave an exposition of Keynesian and Robertsonian economics, followed by a practical simulation of key features of these theories using the hydraulic simulator.



**FIGURE 2** The restored Mark II Phillips machine in the Cambridge University Department of Economics, 2003. A team from the Engineering Department refurbished the machine in preparation for a conference celebrating the 100th birthday of the Cambridge Economics Department, held in September 2003.

the lower pipe represents the flow from the market, thus altering the level of the stocks tank. The openings of the two valves are determined by the supply and demand curves.

Newlyn was enthusiastic and persuaded his head of department at Leeds to advance £100 for construction of a prototype. This prototype, in the grand tradition of such projects, was built over the summer of 1949 in a garage in Croydon [5], [6]. In unpublished notes held by his widow, Newlyn recalls:

Work started in the Easter vacation of 1949, which I was spending in London. We spent some time on discussing the precise specification for the full model, and Bill solved some hydraulic problems such as having constant base outflows from the tanks, and the final drawings were made. The actual construction was carried out in the garage of Bill's friends in Croydon during the summer vacation of 1949. My main role was that of the craftsman's mate—sanding and glueing pieces of

perspex together, while intermittently supplementing some areas of Bill's subsidiary course [that is, rather limited] knowledge of economics.

In the same notes Newlyn testifies to Phillips's ingenuity

in combining electrical and hydraulic features in the articulation, and in manually fashioning, with outstanding skill, critical shapes such as the exponential [note—the true shape is described below] slit of the outflow from the main tank; but perhaps above all his ability to improvise—surely a legacy from his days as a Japanese prisoner of war. An electric motor was required to drive the graph, so he bought a second-hand clock that served the purpose. Pumps were obtained from RAF disposals; windscreen wipers from a Lancaster bomber were adapted for another function; and some of the smaller parts were made by a friend who owned a factory for making dolls' eyes ...

A demonstration that took place at the LSE in November 1949 before a distinguished audience of economists was a great success. Development was subsequently funded by LSE, and the resulting "Type II" machine was ready by autumn 1950. In the same year Phillips published a paper on the machine [7], as a result of which he was appointed to a lectureship—in spite of his poor degree result (his pass degree was the lowest grade) and while still a postgraduate student. He was examined for his Ph.D. in late 1953, was promoted to reader the following year, and became a full professor in 1958.

### THE "TYPE II" MACHINE

Figure 4 is a detailed drawing of the "Type II" Phillips machine from the archives of the LSE. The water flow representing total national income enters at the top of the machine. Taxation revenue is diverted to one side and savings to the other; the remainder

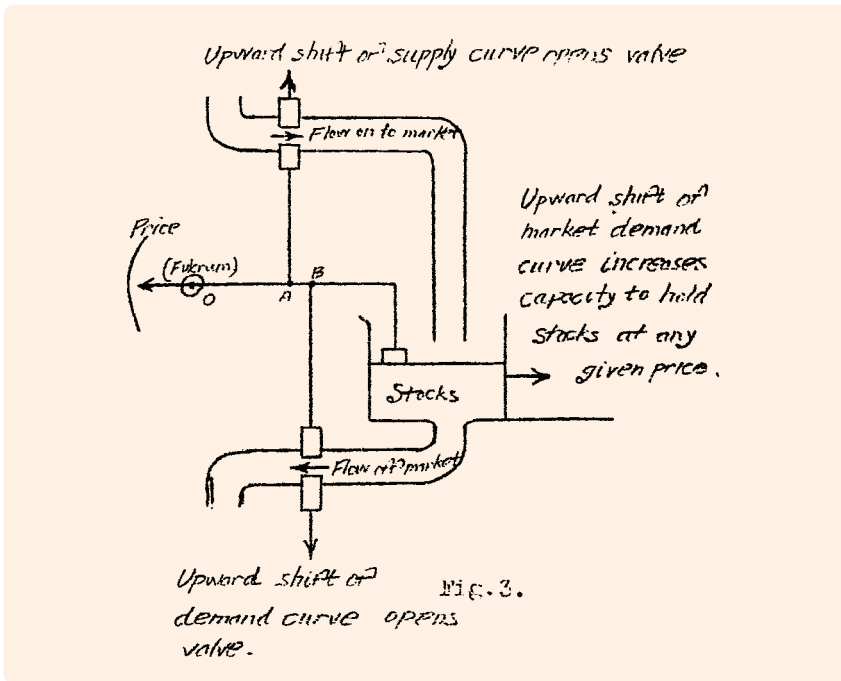

**FIGURE 3** Phillips's sketch of the fundamental component of a hydraulic simulator of an economy, from an unpublished paper now in the possession of Martin Slater, Fellow of St. Edmund Hall, Oxford. This paper was the stimulus for building the prototype machine.

**HYDRAULIC ANALOGUE OF U. S. MONEY FLOW**  
By  
*Phillips & Newlyn*

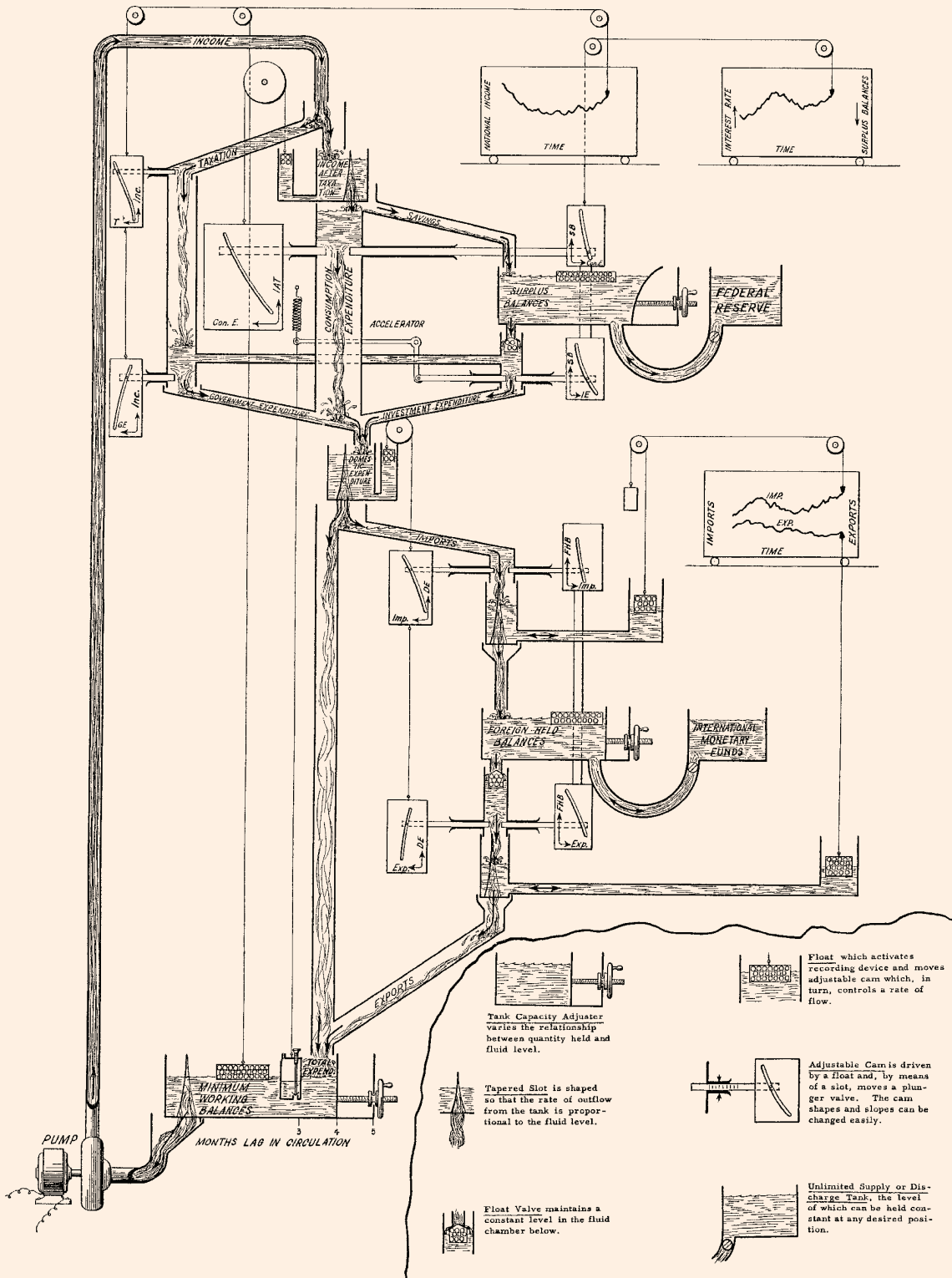

**FIGURE 4** The machine explained in the context of the US economy. The water flowing in the perspex pipes represents the flow of money as income, savings, taxation, imports, and exports, while the levels in the transparent tanks represent stocks of money held as domestic or foreign reserves. (Source: LSE James Meade Archive, File 16/3)

## The Basic Monetary Model

At the heart of the Phillips machine lay a simple, first-order model of the dynamics of an economy, although the machine allowed various higher-order elaborations. In Phillips's own words:

Let  $u$  be the production flow,  $v$  the consumption flow,  $w$  the stocks and  $p$  the price, all measured, for simplicity, from a base at which the system is in equilibrium. We have then, by definition, the identity

$$u - v = \frac{dw}{dt}$$

and three hypotheses,

$$\begin{aligned} u &= lp \\ v &= mp \end{aligned}$$

and

$$w = np$$

where  $l$ ,  $m$ , and  $n$  are parameters.

If at time  $t = 0$ , from equilibrium, there is a spontaneous change,  $\Delta v$ , in consumption, then

$$\frac{dw}{dt} = u - (v + \Delta v) = (l - m)p - \Delta v$$

Also

$$\frac{dp}{dq} = \frac{1}{n}$$

Therefore [after some manipulation]

[...]

$$n \frac{dp}{dt} - (l - m)p + \Delta v = 0$$

The solution of this equation,

$$p = \frac{\Delta v}{l - m} (1 - e^{-\frac{l-m}{n}t})$$

gives the path of the induced price change.

[...]

This simple model could be further developed, in particular by making a distinction between working and liquid stocks, introducing lags into the production and consumption functions, and linking the demand curve for liquid stocks to the rate of change of price [...]. Each of these developments would result in an oscillatory system [...]. [7]

is consumption expenditure. Similarly, flows in other pipes represent imports and exports, while tanks (acting as integrators, from a control engineering point of view) represent financial balances of various kinds. Inflows and outflows between the various components are controlled by valves actuated by floats, pulleys, and servos. In this way, various mechanisms in the economy are simulated, including feedback

introduced by government fiscal control action. Adjustable cams allow the input of arbitrary functions, while tapered slots with a profile inversely proportional to the square root of the height ensure that the outflow from a tank is proportional to the head of water. Pens driven by the water levels representing variables such as interest rates, imports, and exports are used to generate plots against time. An impor-

tant aspect of the machine, as with many other analog simulators, is that the model can run much faster than real time, enabling economic cycles that may take several years to be observed in a few minutes.

In essence, then, the machine solves differential equations; see the sidebar "The Basic Monetary Model." But as Phillips pointed out in his 1950 paper, "The hydraulic model will give solutions for nonlinear systems as easily as for linear ones. It is not even necessary for the relationships to be in analytical form: so long as the curves can be drawn the machine will record the correct solutions, within the limits of its accuracy." Readers interested in a more detailed description of the machine's design and function are referred to the relevant chapters of [3].

The machine was claimed to have an accuracy of  $\pm 4\%$ , and thus was never viewed as a highly accurate computational device. Its real significance seems to lie in the way it aided understanding of complex ideas of economics, particularly dynamics. The pedagogical value of the machine was recognized by its inventors. Writing in 1950, Newlyn remarked

The outstanding feature of the model is that it permits a visual demonstration of the process of change in a multivariable system, in which the variables are functionally related. It can be used at different levels according to the sophistication of the student, and is best used in tutorial work with one or two students who can actually participate in the experiments [...] [The machine is particularly useful] at that stage of perplexity and confusion which occurs when the student has encountered a considerable number of apparently conflicting ideas and is trying to reconcile them. It was with this state of confusion in mind that the model was originally conceived and it is at this stage that it has been found to be of most value. [8]



Those who used the machine or observed it in action made comments similar to remarks made by the users of other analog simulators of the period. For example, users were enthusiastic about the way the device gave a “feel” for economic behavior, presented visual (rather than numerical) results, and was accessible without explicit advanced mathematics.

But the Phillips machine was different from other analog simulators of the time in one highly significant respect: the flow of water through transparent pipes and tanks rendered the time variation and steady-state values of all of the variables immediately apparent. There was something direct about the money/water analogy that an electronic analog computer, say, would have been unable to reproduce, even though the computational accuracy of the latter might have been higher. As Morgan and Boumans remark:

All the records show that the demonstrative power of the Phillips machine made a deep impression. Seeing the machine working is different from pictures of it, as those who have seen the Phillips machine working readily attest. Spectators could not only see the red water streaming through the pipes, but also hear the bubbling and splashing as it ran through the machine. They were able to see not a 2-D picture or system of equations, or even a static 3-D representation, but the kind of interrelated and dynamic cause-effect changes over time that economists suppose to happen in the circular flow of the aggregate economy. The working machine was a 4-D representation. [9]

In all, about a dozen machines were built, ultimately ending up not only in British universities but also as far afield as Melbourne, Australia; Roosevelt College, Harvard; the Ford Motor Company; and the Central Bank of Guatemala! One machine was built as a mirror image of Figure 4, so that two national economies

could be interconnected to simulate their interaction, something that appears to have led to important new insights into the dynamics of international economies [6, p. 108].

Apart from the continuing use of the prototype at Leeds by Newlyn until his retirement in the late 1970s, the machines fell into disuse as other computation and simulation methods became available. In the late 1980s a machine was renovated by the Suntory-Toyota International Centre for Economics and Related Disciplines and used for demonstrations. This machine is now on permanent display at the British Science Museum. The most recent full renovation is the Cambridge machine shown in Figure 2, which is being used again for demonstration purposes in the economics first-year lectures! The Leeds prototype is also being restored.

#### PHILLIPS'S LATER WORK

Phillips is probably remembered in economics circles primarily for the Phillips curve, which aroused some controversy and even hostility. The curve, published in 1958, expressed a relationship between unemployment and wage changes [10]. It was based on fitting a curve to empirical data, but at its root is a dynamic economic model (albeit highly simplified) informed by Phillips's experience with the machine and his understanding of control theory; see the sidebar “Three-Term Control of an Economy.”

Phillips had already exploited classical control theory in economic models in two earlier papers in the *Economic Journal* in 1954 and 1957, in which he addressed the problem of stabilizing an economy, including a description and analysis of the use of integral and derivative action as well as proportional control [11], [12]. It seems highly likely that Phillips's work on the machine greatly assisted his general insights into the dynamics of economic systems. Clearly, with a background in electrical engineering, Phillips was in a good position to apply the comparatively new

discipline of classical control to problems of economics and related areas. Indeed, he was not the only engineer to do this. Arnold Tustin wrote a book on the topic [13], [14], which Phillips reviewed for *Economic Journal* in 1954. Jay Forrester, one of the major contributors to the development of computer technology, also applied engineering ideas, particularly control engineering ideas, to the study of industrial production and society in general from the late 1950s onwards [15].

Phillips's last published papers owed much to contemporary developments in control and system dynamics, covering such matters as optimization, parameter estimation, and moving-average errors.

#### CONCLUSIONS

The Phillips machine is unusual, perhaps unique, in the world of analog computers and simulators in employing hydraulic components to simulate dynamic systems, rather than electrical or mechanical devices. Indeed, it seems likely that Phillips knew little about contemporary electronic simulators until some time after the construction of his machine, when he collaborated with Richard Tizard of the National Physical Laboratory on links between economics and control theory [4].

While the machine may seem quaint to us now, it is difficult to imagine that any other contemporary simulator would have been quite so successful in directly demonstrating the dynamic behavior of an economic system both to students and professional economists.

#### ACKNOWLEDGMENTS

Figures 1 and 4 are reproduced courtesy of the LSE, although it has not been possible to trace the copyright holder of Figure 4. Figure 2 is copyright of the Marshall Society, Cambridge University, and Figure 5 is reproduced by permission of Blackwell Publishing. Allan McRobie, of the Cambridge University Engineering Department, demonstrated the

## Three-Term Control of an Economy

In 1954 Phillips published [11], based on his Ph.D. thesis, in which he applied classical control theory explicitly to the stabilization of an economy:

[...] if any stabilisation policy is to be successful it must be made up of a suitable combination of proportional, integral and derivative elements. A strong proportional element is needed as the basis of the policy, sufficient integral correction should be added to obtain complete correction of an error within a reasonable amount of time and an element of derivative correction is required to overcome the oscillatory tendencies which may be introduced by the other two elements of the policy. If the system itself has a considerable tendency to oscillate [...], the integral element in the policy should be made very weak or avoided entirely, unless it can be accompanied by sufficient derivative correction to offset the destabilising effects [...].

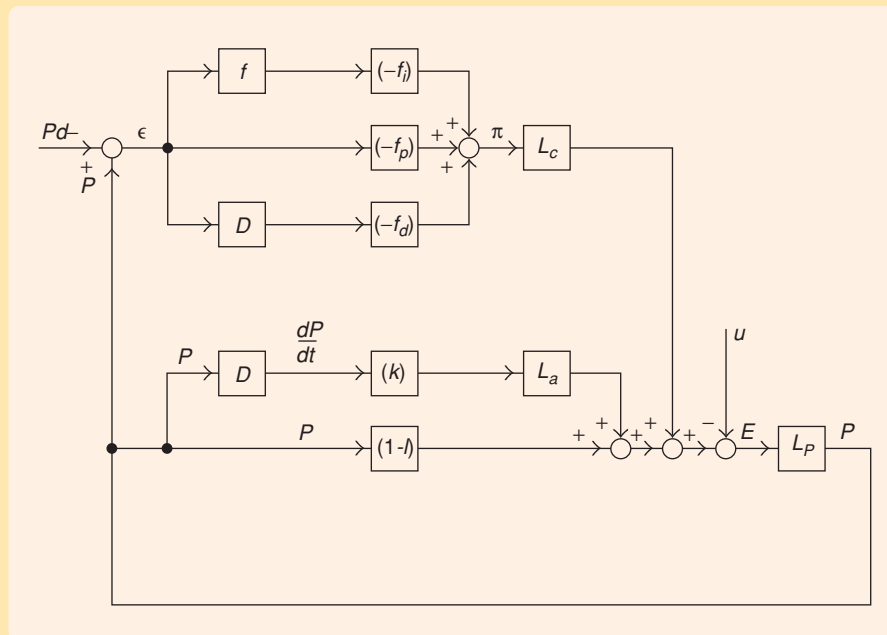

**FIGURE S1** Phillips's illustration of three-term stabilization of an economy from [11]. The lower part of the diagram represents the model of the economy relating production  $P$  to demand  $E$ . Stabilization using integral, proportional, and derivative terms is shown in the upper part of the diagram. Notice that various pure time lags  $L_x$  are included in the model. A detailed explanation is given in the original paper and related articles in [3].

Phillips machine in action, and Bjoern Hassler supplied a short video sequence that can be viewed at [www.culive.org/AllanMcRobie](http://www.culive.org/AllanMcRobie). Robert Leeson very kindly read a draft of this article and made helpful comments. Doreen Newlyn talked to me at length and supplied a copy of Phillips's original, unpublished paper (from which Figure 3 is taken) and her late husband's notes.

### AUTHOR INFORMATION

**Chris Bissell** is professor of telematics at the UK Open University, where he recently celebrated 25 years of service. He has written distance-teaching materials on control engineering, telecommunications, information technology, signal processing, and media studies. His major research interests are in the history of technology and engineering education.

### REFERENCES

- [1] J. Meade, "That's the way the money goes," *LSE Society Mag.*, pp. 10–11, Jan. 1951.
- [2] "The Moniac," *Fortune Mag.*, pp. 100–101, Mar. 1952.
- [3] R. Leeson, Ed., *A.W.H. Phillips: Collected Works in Contemporary Perspective*. Cambridge, UK: Cambridge Univ. Press, 2000.
- [4] D. Swade, "The Phillips machine and the history of computing," in *A.W.H. Phillips: Collected Works in Contemporary Perspective*, R. Leeson, Ed. Cambridge, UK: Cambridge Univ. Press, 2000, pp. 120–126.
- [5] W. Newlyn, "The origins of the machine in a personal context," in *A.W.H. Phillips: Collected Works in Contemporary Perspective*, R. Leeson, Ed. Cambridge, UK: Cambridge Univ. Press, 2000, pp. 31–38.
- [6] N. Barr, "The history of the Phillips machine," in *A.W.H. Phillips: Collected Works in Contemporary Perspective*, R. Leeson, Ed. Cambridge, UK: Cambridge Univ. Press, 2000, pp. 89–114.
- [7] A.W. Phillips, "Mechanical models in economic dynamics," *Economica*, vol. 17, no. 67, pp. 283–305, 1950. (Reprinted as Chapter 10, pp. 68–88, of Leeson.)
- [8] W. Newlyn, "The Phillips/Newlyn hydraulic model," *Yorkshire Bull.*, vol. 2, no. 2, pp. 110–127, Nov. 1950.
- [9] M.S. Morgan and M. Boumans, "Secrets hidden by two-dimensionality: the economy as a hydraulic machine," in *Models: The Third Dimension of Science*, S. De Chadarevian and N. Hopwood, Eds. Stanford, CA: Stanford Univ. Press, 2004, chap. 13, pp. 369–401, .
- [10] A.W. Phillips, "The relation between unemployment and the rate of change of money wage rates in the United Kingdom, 1861–1957," *Economica*, vol. 25, no. 100, pp. 283–99, 1958. (Reprinted as Chapter 28, pp. 269–281, of Leeson.)
- [11] A.W. Phillips, "Stabilisation policy in a closed economy," *Economic J.*, vol. 64, no. 254, pp. 290–323, 1954. (Reprinted as Chapter 16, pp. 134–168, of Leeson.)
- [12] A.W. Phillips, "Stabilisation policy and the time-forms of lagged responses," *Economic J.*, vol. 67, pp. 265–77, 1957. (Reprinted as Chapter 17, pp. 169–183, of Leeson.)
- [13] A. Tustin, *The Mechanisms of Economic Systems—An Approach to the Problems of Economic Stabilisation from the Point of View of Control-System Engineering*, Heinemann, 1954.
- [14] C.C. Bissell, "Pioneers of control: an interview with Arnold Tustin," *IEE Rev.*, pp. 223–226, June 1992.
- [15] J.W. Forrester, "Industrial dynamics: a major breakthrough for decision makers," *Harvard Bus. Rev.*, vol. 36, no. 4, pp. 37–66, Jul–Aug, 1958.

