



1981

A WATFIV Implementation and Evaluation of a Rubric for the Reduction of Extraneous Variability in the Observed Frequency of Infant State Transitions

James A. Swartz
Loyola University Chicago

Follow this and additional works at: https://ecommons.luc.edu/luc_theses



Part of the [Psychology Commons](#)

Recommended Citation

Swartz, James A., "A WATFIV Implementation and Evaluation of a Rubric for the Reduction of Extraneous Variability in the Observed Frequency of Infant State Transitions" (1981). *Master's Theses*. 3227.
https://ecommons.luc.edu/luc_theses/3227

This Thesis is brought to you for free and open access by the Theses and Dissertations at Loyola eCommons. It has been accepted for inclusion in Master's Theses by an authorized administrator of Loyola eCommons. For more information, please contact ecommons@luc.edu.



This work is licensed under a [Creative Commons Attribution-Noncommercial-No Derivative Works 3.0 License](#).
Copyright © 1981 James A. Swartz

A WATFIV IMPLEMENTATION AND EVALUATION OF A RUBRIC
FOR THE REDUCTION OF EXTRANEEOUS VARIABILITY IN THE
OBSERVED FREQUENCY OF INFANT STATE TRANSITIONS

by

James A. Swartz

A Thesis Submitted to the Faculty of the Graduate School
of Loyola University of Chicago in Partial Fulfillment
of the Requirements for the Degree of

Master of Arts

September

1981

ACKNOWLEDGEMENTS

Gratitude is extended to Dr. Jill Nagy and Dr. Deborah Holmes for their helpful advice and comments regarding the background literature and for affording me access to their clinical data. Without the benefit of their ongoing research at Evanston Hospital and their interest in the study of infant state behavior, this project would not have been possible.

Special thanks are due Dr. Frank Slaymaker, thesis director. His knowledge of computer programming and statistical analyses was invaluable during the writing of the program and the subsequent modifications that were necessary. He also gave generously of his time and energy in correcting and proofing the body of the paper. It was at his suggestion that this study was undertaken.

Finally, I would like to dedicate this paper to the memory of my grandfather, the late Anthony Chiurazzi, for his friendship and love at a time when it was most needed.

VITA

The author, James Anthony Swartz, is the son of James Clarence Swartz and Gloria (Chiurazzi) Bennett. He was born December 26, 1955, in Valley Forge, Pennsylvania.

His elementary education was obtained in the public schools of New Castle, Pennsylvania, and Howland, Ohio. His secondary education was gained at Kennedy Christian High School, Hermitage, Pennsylvania, where he graduated in 1973.

In September of 1973, he entered the University of Notre Dame in South Bend, Indiana, and in May of 1977, received the Bachelor of Arts degree with a concentration in pre-professional studies and a minor in psychology. While attending Notre Dame he served as a writer on the staff of the school magazine and won an English Department award for his original short story, "Thesis, Antithesis, Synthesis." He was also actively involved with the campus jazz festival, and during his senior year he was selected chairman in charge of publicity.

In September of 1977, he was accepted into the Master of Arts program in behavioral research at Loyola University of Chicago. In April of 1979, he began working as a clinical therapist at Northwestern Memorial Hospital on a closed psychiatric unit. During the Spring two years later he was accepted into the Ph.D. program in clinical psychology offered through the Department of Psychiatry and

Behavioral Sciences at the Chicago Campus of Northwestern University. He began his studies in that program in September of 1981. In January of 1982, he was awarded the Master of Arts degree from Loyola.

TABLE OF CONTENTS

	Page
ACKNOWLEDGEMENTS	ii
LIFE	iii
LIST OF TABLES	vi
LIST OF FIGURES	vii
INTRODUCTION	1
The Problem of Definition	4
The Problem of Assessment	10
METHODS	20
Subjects	20
Procedure	20
Analysis	23
RESULTS	42
DISCUSSION	61
Taxonomic Refinement	61
Reduction of Extraneous Variability	64
Epoch Length	70
REFERENCE NOTES	72
REFERENCES	73
APPENDIX A	75
APPENDIX B	84
APPROVAL SHEET	94

LIST OF TABLES

Table	Page
1. Summary of References to Observed Transition Periods in Infant State Behavior	15
2. Analyses of Variance	22
3. Group Means for Raw and Smoothed Data	55
4. Definitions of Flow Chart Symbols	86

LIST OF FIGURES

Figure	Page
1. A Sample Printout for One Subject	43
2. A Comparison Between A Raw and a Smoothed Data Stream	49

INTRODUCTION

In the context of developmental research, the term state is an abstraction that refers to observed clusters of behavior that occur with regularity and specificity. These groups of behaviors, or states, are thought to represent neurological functioning and organization, although the nature of the relationship is undetermined as yet. The state of quiet sleep is exemplary. An infant is said to be in the state of quiet sleep when he or she is lying with eyes closed, breathing regularly, and there is an absence of both rapid eye movement (REM) and marked motoric behavior (movement of limbs). Similarly, a number of other states in infants have been identified, although the exact definitions used as well as the nosology and defining criteria vary from researcher to researcher. The difficulty of arriving at a precise taxonomy of state is discussed below in more detail.

An extensive body of literature indicates that an infant's state behavior is a frequently used measure in developmental research (cf. Ashton, 1973; Berg & Berg, 1979; Dunn, 1977; Holmes, Nagy, Slaymaker, McNeal, Gardner, & Pasternak, Note 1). Even for the researcher not directly interested in studying infant states per se, unless the independent variable is known to have large effects, states must be taken into account whenever infant behavior is being investigated (Escalona, 1962; Korner, 1972).

Various studies have demonstrated that an infant's response to identical stimuli varies in type and magnitude dependent upon what state he is in at the time the stimulus is presented. Berg and Berg's (1979) review of the studies in this area noted that with the exception of tactile stimulation, responsivity to various stimuli (e.g., olfactory, auditory) differed between sleep states. Research using physiological measures as the dependent variable (e.g., heart rate, respiration rate) failed to produce a consistent response pattern in the subjects studied or significant findings until the initial state had been taken into account by use of statistical techniques (Escalona, 1962). Korner (1972) noted from her own work with neonates that the response elicited by auditory stimulation is greater when the infant is in the states of irregular sleep, drowsiness, or alert inactivity at the time of stimulation. By comparison, it is very difficult to elicit a response from the infant who is in the states of regular sleep or crying.

In the same paper, Korner elaborated two types of errors that can occur in infant research when the experimenter does not take into account those effects that are attributable to state behavior. Both types of error are caused by the uncontrolled variability that is added to the data and, dependent upon what effects the experimenter is looking for, can cause either false positive or false negative results. For the experimenter who is studying individual differences in infants, false positive results may be obtained as the differences in the data between two conditions may simply reflect differences in state at the

time of stimulus presentation. Conversely, when the experimenter is looking for treatment effects, false negative results may occur due to inflated subject variability. Matters are complicated further by evidence from early research which indicates that the effects of state on elicited behavior may be different for responses that tap some aspect of the sensorium (e.g., vision, pain threshold) versus responses involving motoric behavior such as reflexes and motility (Escalona, 1962).

As a variable in its own right, infant state has been researched along at least three axes: (1) psychophysiological studies arising from "studies of the function and physiology of sleep" (Thoman, 1975a). These studies measure developmental and pathological changes in central nervous system (CNS) functioning and how these changes are manifested behaviorally as changes in state (cf. Parmelee, Schulz, & Disbrow, 1961; Parmelee, Wanner, Akiyama, Schultz, & Stern, 1967; Prechtl, Theorell, & Blair, 1973; Roffwarg, Muzio, & Dement, 1966; Spitz, Emde, & Metcalf, 1970); (2) psychosocial research directed at discovering how infant state behavior mediates and elicits various caretaker responses and conversely how various caretaker behaviors influence infant states (cf. Dunn, 1977; Korner, 1972; Korner & Grobstein, 1966; Korner & Thoman, 1970; Lewis, 1972; Moss, 1967; Osofsky & Danziger, 1974); and (3) research on the state variable requiring more refinement as well as consistency with regard to the different categories used for classifying states (cf. Ashton, 1973; Brown, 1964; Korner, 1969, 1970, 1972; Thoman, 1975a, 1975b; Wolff, 1959).

These three areas of research on the state variable are neither exhaustive nor exclusive; other authors have used different taxonomies for organizing the literature (cf. Ashton, 1973) and some of the studies reviewed do not fall neatly into any one category. For example, recent research by Holmes et al. (Note 1) studied the effects of psychophysiological organization on psychosocial functioning. The purpose of using the above three categories is to illustrate the importance of the concept of state in infant research by highlighting the diverse areas in which state is utilized as a variable. Thoman (1975a) has described an infant's behavioral state as "his most continuous characteristic," and even Ashton's pessimistic review of the literature concludes with a call for further research in the area.

Despite the wide usage of the state variable, however, there have been problems encountered in implementing the concept in research strategies; all of the above three areas have reported some amount of difficulty in assessing an infant's state. Basically, these difficulties can be traced to two sources: (1) the problem of defining the state variable and arriving at an agreed upon taxonomy and nosology, and (2) the problem of correctly "reading" or assessing an infant's state, especially during transitions between states.

The Problem of Definition

Defining the state variable has been more difficult than actually conducting research that purports to study state behavior. Yet it is easy to see that without a clear or consistent definition

of state, different researchers will obtain varying results dependent upon the definition used. Ashton (1973) has noted that there are two trends in defining state, neither of which has been completely satisfactory. Wolff's (1959) early research which represented one of the first systematic studies aimed at classifying infant behavior, is illustrative of the first of these two trends.

Wolff defined state in terms of "stable and distinguishable patterns of behavior." He assumed that certain behaviors occurred with regularity, in clusters, and that "state" was a way of referring to the internal organization of the infant as it was manifested by these predictable groupings. For example, regular and irregular sleep were two of the categories used by Wolff. Regular sleep was indicated when the infant's respirations were smooth and even and there was a relatively low rate of startles or other movements. In contrast, the state of irregular sleep was marked by rapid, shallow and irregular respirations, as well as frequent startles and movements. Infants were also found to be more likely to startle in response to jarring when in the state of regular sleep.

The second trend in defining the state variable has been to refer to each state as being reflective of a level of arousal or level of consciousness (cf. Brown, 1964). Defining state in this way stems from the belief that state behavior lies on a continuum. At one end of the continuum are low levels of arousal or awareness (e.g., quiet sleep) while at the opposite end are high levels (cognitive alert, crying). The assumption that the state variable is representative of

a level of arousal or consciousness has been called into question by numerous writers (cf. Ashton, 1973; Dunn, 1977; Korner, 1972; Lewis, 1972). The crux of the argument against using level of arousal as a defining point is that there is no single measure that is entirely indicative of arousal level, thus, "many parameters must be considered before a particular state rating can be assigned to a baby" (Ashton, 1973). Using several measures of arousal is also not feasible. As Dunn (1977) argues, arousal is an ill-defined term and the different states do not correlate well with the traditional measures of arousal such as heart rate, breathing rate, and blood pressure.

In addition, arousal level or level of consciousness is sometimes contradictory with regards to an infant's responsiveness to stimulation. As has been mentioned earlier, whether or not an infant will respond to a given stimulus depends as much on the kind of stimulus employed as it does on the state that an infant is in at the time of stimulation. Given a particular type of stimulus, it is conceivably possible to elicit a large response in terms of frequency or magnitude from an infant deemed to be in a low state of arousal (e.g., quiet sleep). In short, level of arousal or consciousness is too crude and too poorly understood in their own right to serve as reliable criterion for a definition of state.

The first trend in defining state—a conceptual entity representative of an underlying neurophysiological organization, manifested by regularly occurring clusters of behavior—is the more promising of the two but requires greater precision in nomenclature and taxonomy

than has been used previously. Ashton (1973) has discussed the discrepancies between various systems of classification and errors due to imprecise criteria and measurements in past research. He notes that the confusion of terms used by different researchers can lead to misinterpretations. One researcher might distinguish the categories of active sleep with REM and active sleep without REM, while a different researcher might utilize only a single category of active sleep.

Some progress has been achieved in this area, however. Korner (1972) has pointed out that with respect to state categories, "the overlap of criteria far exceeds the differences." In a study which looked at the frequency of occurrence of spontaneous behaviors (e.g., reflex smiles, erections, startles) in the context of the state in which they occurred, Korner (1969) found "a highly significant relationship between state and the type and frequency of spontaneous behaviors." These results support the concept of regularly occurring clusters of behavior and also the meaningfulness of the state variable as a measure of infant behavior. Thoman (1975a) has also discussed the advances being made with regard to refinement of criteria for assessing a particular state as well as agreement on a taxonomic system. She cites a conference at which behavioral and physiological criteria (EEG, EMG, EOG, heart rate, and respirations) as well as nomenclature were agreed upon for scoring of states of sleep and wakefulness in newborn infants. For both the researcher of psychophysiological phenomena and the researcher primarily interested in studying behavior, the principle of valid assessment is identical:

concordance of several measures. Achieving precise taxonomy of the state variable is dependent upon several measures whether these are behavioral or physiological. In the case of the researcher interested in studying behavior, for whom "physiological measures are irrelevant if not intrusive" (Thoman, 1975a), this translates into defining and assessing a state by the presence of several behavioral criteria. (In the present study, the state of active sleep without REM is defined by the presence of motor activity and by the absence of eye movements.) Accordingly, Thoman's research (1975a, 1975b) used this strategy with the goal of refining the state concept.

Her taxonomic scheme subdivides the categories of quiet sleep into quiet sleep A and quiet sleep B (based on criteria that are explained in her paper), and the state or category of active sleep into active sleep with and without REM and active sleep with dense REM. Studying full-term, normal infants (i.e., no prenatal, perinatal, or postnatal complications) and utilizing 10-second periods for recording an infant's state (because of the observation that state durations are extremely short in highly volatile infants), Thoman found that individual infants are very consistent with respect to the amount of time spent in each subcategory of active sleep. There was no significant correlation for amount of time spent in the overall category of active sleep, however, providing justification for the subcategories chosen. Additional evidence for the validity of her classificatory scheme came from the recording of state related behaviors during the observations. Thoman found that the rate of occurrence of different behaviors varied

as a function of the state of the infant. Mouthing or sucking occurred much more frequently when the babies were in the states of active sleep versus the quiet sleep states. Other behaviors such as frowns, startles, or jerks varied in frequency according to the subcategories used for dividing up active and quiet sleep. These results agree with the findings of Korner (1969) mentioned above and of other authors (e.g., Wolff, 1959) who have shown the relatedness of infant state and the spontaneous occurrence of various behaviors normally observed in infants.

The findings of the Thoman study aid in the effort to refine state categorization and nomenclature. Her state categories represent a groundwork substantiated on precise defining criteria and observational techniques. Problems were encountered though, in the analysis of some of the subcategories used. While discussing a table of the transition frequencies between states, she remarks that "the subcategories of quiet and active sleep are not separated because there were a great many seemingly unpatterned transition periods" (i.e., the interval of time during which the infant is changing from one state to another). Thoman also observed that an infant gives mixed signals of sleeping and wakefulness simultaneously. Brown (1964) is another researcher who has also remarked on the sometimes capricious nature of changes between states.

Brown's purpose was similar to Thoman's: establishing a classificatory scheme for states in terms of categories and criteria for the assessment of an infant's state. Like Thoman, she also found

that state was a meaningful and consistent measure of infant behavior. She noted, however, that during observation periods, there were often brief fluctuations in state that were not scored as true changes. No explanation is offered as to what decision procedure was used for determining when a fluctuation in state was a "true change." One likely possibility is that a brief transition from one state to another followed by a return to the original state was not scored as a true change until the second state was assumed for a longer period of time. Whatever the procedure used, these remarks by Brown and Thoman indicate that at times, state behavior is difficult to evaluate within the framework of the classificatory scheme used.

The Problem of Assessment

The difficulty in finding an agreed upon taxonomy of state behavior and the problems of using any taxonomy when overt behavior is used as the defining criteria (as opposed to covert behavior; e.g., psychophysiological measures) is directly related to the lack of organization and stability of infant behavior (Berg & Berg, 1979). Holmes, Nagy, Pasternak, Slaymaker, and Hall (Note 2) note that the lack of organization of infant behavior is reflected in "the poor correlations among the various indices of state, such as EEG patterns, respiration rates, and body and eye movements." The difficulties encountered by Brown and by Thoman then, are general with respect to infant state research, particularly when attempts are made to subcategorize the sleep states where infant behavior is particularly unstable. The problems of definition and taxonomy can thus be viewed as interrelated to

the difficulty of assessing behavior that correlates only poorly into discrete clusters.

Holmes et al. (Note 2) also remark that despite the paucity of organization in infant behavior, most researchers assume that infant states, like adult states, have some measure of temporality and stability. That is, an infant remains in a state for a certain period of time once he has entered that state. Thus, infant state behavior is seen as having a periodicity or pattern that preshadows the periodicity of adult states, as opposed to being randomly organized. Because the infant state data is "noisy" with rapid and seemingly unpatterned transitions, however, researchers have had to adopt various strategies to sift out the unwanted variability. Two ways of doing this which are not mutually exclusive in practice, but which will be discussed separately here are (1) creating a category for undefined or transitional state behavior which does not satisfy the criteria for assignment to one of the taxonomic categories used (Berg & Berg, 1979); or (2) using a sampling technique whereby state behavior is "averaged" over intervals of time so that the predominant state is the one recorded for each interval (Holmes et al. Note 2). Examples of the first method of handling state data—the inclusion of a category of undefined behavior—are numerous and typical of much of the research done in this area. Korner (1972) has written about "indistinctness" of state, but in a specific context.

In a paper that reviewed the roles of the state variable in infant research, Korner (1972) called for the inclusion of the separate

category of indistinctness of state when the observed behaviors did not clearly match any of the criteria used for assigning a particular state. She reasoned that indistinctness of state is an important variable in its own right and may have implications for the quality of maternal care (i.e., mothers of infants who show a great amount of indistinct behavior may have problems in reading the infant's behavior and consequently in knowing how to respond to the infant's needs). Thus, indistinctness of state is seen as being applicable to a subpopulation of infants whose behavior does not fit precisely with the accepted state categories. Similarly, other authors have researched specific subpopulations with the results that some of the observed behavior was difficult to categorize.

For example, Parmelee et al. (1976) found that premature infants spend a greater amount of their sleep time in an "ill-defined" active sleep state as opposed to full-term infants who spend a higher percentage of their sleep time in the state of quiet sleep. Using both behavioral criteria and EEG recordings, Parmelee et al. noted that preterms were most frequently in a period that they labeled transitional sleep. They used this category because they found it difficult to classify preterms as being in either active sleep or quiet sleep according to the criteria that the researcher used for assignment to either of those categories. The "ill-defined" active sleep or transitional sleep gradually decreased with maturity, and the infants' sleep fit into the categories of active or quiet sleep. The authors concluded that these results represented the effects of neurophysiological maturation in the preterm infant.

The findings of an ill-defined sleep state in the 1967 study by Parmelee et al. supports the findings of an earlier study by Parmelee and his associates (Parmelee, Schulz, & Disbrow, 1961). (In this study no information is given as to the age of the subjects or if there were any special characteristics of the sample.) Looking at the time spent by infants either asleep or awake, the authors noted a periodicity in the sleep-wake cycle and postulated that "primitive sleep" predominates in newborn infants, marked by an automatic internal periodicity attributable to some as yet unknown CNS mechanism. The authors also cited another study which concluded that "the premature infant delivered after only 6 or 7 months gestation does not show any differences in the EEG patterns (between states) and the clinical differences are slight." This is in contrast to the preterm infant of 8 months gestation who showed a markedly more differentiated pattern of sleep-wakefulness in his EEG tracings.

These studies indicate that preterm infants manifest their state behavior less clearly than do full terms. This suggests that immaturity of the CNS is involved directly with the distinctness of state behavior. Spitz et al. (1970) reported finding that in early infancy REM accompanied by a low amplitude EEG pattern with fast and irregular rhythms occurs indiscriminately during the states of sleep, drowsiness, fussing, and crying up until the third month of age when a more distinctive pattern emerged. Given this evidence, it is reasonable to hypothesize that the amount of time an infant spends in a transitional period (that is ambiguous with respect to the state categories

used for observation) is inversely proportional to the degree of integrity and maturity of the CNS. The older the infant, the clearer cut and shorter the transitions, and the more well-defined the state manifestations. Thus, the attribute "indistinctness of state" noted by Korner may be indicative of an immature and/or damaged CNS in some infants.

In general, however, all infants, including those that are full term and normally developed for their gestational age, manifest through their EEG patterns and state behavior what has been most frequently described as being transitional periods. The subjects of both the Brown and the Thoman studies, discussed previously, were full term. Research by Roffwarg et al. (1962), which studied the maturational changes that occur in the EEG patterns and sleep states in the neonate during the first weeks of life, encountered similar ambiguities. Roffwarg and his associates found that between the well-defined stages of REM and non-REM (nREM) sleep, there occurred an EEG pattern composed of an admixture of the EEG patterns characteristic of each of the well-defined periods. They termed this pattern a "transitional phase EEG." The subjects studied in this case were also full-term infants. These references to observed transition periods by the various authors cited in this paper are summarized in Table 1.

While the behavior of preterms is less well organized than that of full-term infants, the above studies indicate that the behavior of full terms is also difficult to assess. Berg and Berg (1979) have dis-

Table 1

Summary of References to Observed
Transition Periods in Infant State Behavior

Author(s)	Reference	Measure	Subjects
Thoman	unpatterned transitions in states	behavioral observations	full term
Brown	brief fluctuations in state	behavioral observations	full term
Korner	indistinct states	not mentioned	not mentioned
Parmelee et al. (1961)	(no) differentiation between sleep and wakefulness	EEG & behavioral observation	preterm
Parmelee et al. (1967)	ill-defined active sleep	EEG & behavioral observation	preterm
Roffwarg et al.	transitional phase EEG	EEG & behavioral observation	full term
Spitz et al.	indiscriminate REM & EEG pattern occurring during several states	EEG & behavioral observation	full term

cussed this point: "Definition of states is considerably less difficult in full-term infants than in prematures, but state components still show varying degrees of immaturity at term." They also discuss the results of the Parmelee et al. study (1967) that was reviewed above, whereby the choice of criteria for defining the occurrence of a state directly effected the results. The implications of these findings for the present paper warrant a second look at that study.

It will be recalled that Parmelee and his associates used the three categories of active sleep, quiet sleep, and transitional sleep. Behavior that was not assignable to the first two categories was placed in the latter. The data collected was scored using two different sets of criteria. The first set specified six different criteria, of which four had to be met before an infant's behavior was classified as representing either active sleep or quiet sleep. Behavior that did not satisfy these specifications was classified as transitional sleep. Included in the six criteria were both behavioral (e.g., eye movements, motoric activity) and psychophysiological (e.g., heart rate, EEG) measures. The second set of criteria consisted of three behavioral measures (motoric activity, eye movements, and respirations), of which all three had to be present before a state was scored. In the data analysis, it was found that when behavioral measures alone were used, the amount of active sleep observed greatly decreased compared to the amount found using the combined physiological and behavioral criteria (this initial variance decreased over gestational age). The state of quiet sleep remained stable across sets of criteria, while the amount

of transitional sleep increased when the behavioral criteria were used, apparently at the expense of active sleep. The authors used these results to support their contention that the state of active sleep is "ontogenetically primitive." With respect to the present study, which is concerned with the assessment of infant state using strictly overt behavioral criteria, these results have a second implication: in contrast to physiological measures, the assessment of infant states by behavioral observation is confronted with more variability and behavior that is more poorly organized (i.e., the larger amounts of transitional sleep found by using the strictly behavioral measures).

The second method that researchers use for handling these data, to mitigate observed variability and reduce flux in state patterns, is to employ an averaging procedure. In this type of approach, intervals of varying length are chosen, ranging from the 10-second intervals used by Thoman (1975a) to 3 minutes used by Theorell, Prechtl, Blair and Lind (1973), and the data are averaged over the time interval so that the predominant state is the one recorded. Recently, however, Holmes et al. (Note 2) have shown that the size of the interval chosen directly effects the proportions of state behaviors obtained. When behavioral state data were averaged over 10-second, 20-second, and 100-second periods, it was found that the ratio of REM sleep to quiet sleep varied directly in accordance to the size of the interval used. That is, as interval size increased, the percentage of quiet sleep decreased, while the percentage of active sleep increased. This result suggests that discrepant reports in the literature concerning infant state behavior

may be attributable to the variation in interval length used. It also suggests, again, that the subcategories of the sleep states are the most difficult to classify (the interval length had no effect on the non-sleep states and the overall time in the sleep states).

These findings present a conundrum to the researcher interested in assessing state behavior without the aid of psychophysiological measures. On the one hand, state is assumed to be a meaningful measure of infant behavior that reflects patterns of activity and development. In fact, the overall categories of REM sleep, nREM sleep, and wakefulness do seem to be stable and distinguishable (Berg & Berg, 1979). On the other hand, infant behavior is disorganized enough that assessment by purely behavioral criteria may differ in results from assessments that tap physiological measures. In particular, periods yielding mixed signals that have been formerly classified as transition periods present the greatest difficulty.

The present study proposes a method of controlling for the variability arising in infant state data due to the instability of infant behavior. The method consists of a hierarchical set of rules (a rubric) which, taken a priori, forms a basis for establishing whether or not a "true" change in state has occurred. When implemented by a computer program, the rubric transforms the raw data by redefining the random changes in state, effectively absorbing them into the data stream. The result is a data vector free of ambiguous transition patterns and longer within state epochs. Such a procedure may be con-

strued as being a smoothing process and the resultant data vector as being a smoothed data vector.

A byproduct of the rubric is that it also can be used as an instrument for aiding in taxonomic refinement. Given a particular set of categories with each category representing a distinct state (e.g., quiet sleep, active sleep, alert inactivity), a researcher might find that what he originally labeled a state was only a transition period between states. This would become clear when, after implementing the rubric, the majority of the previously recorded instances of the spurious state were absorbed into other states. To take an example from Thoman's study (1975a), the state of active sleep with dense REM might not be a separate category of state behavior. If, after being evaluated by the program, it was found that most of the occurrences of active sleep with dense REM are absorbed into the state of active sleep with REM, a researcher could conclude that these two states describe behaviors that are essentially indistinguishable. Thus the program serves as both a statistical adjunct for the reduction of extraneous variability and possibly as an aid to taxonomic refinement. The final result of analyzing state data with the program is that the patterning of state behavior (periodicity) is made more apparent.

METHODS

Subjects

Subject data was obtained from data collected on infants in an ongoing study at Evanston Hospital (The National Foundation March of Dimes, Grant Number 12-34). Thirty-six subjects were used with all subjects selected according to three criteria: (1) no evidence of congenital or suspected nervous system damage; (2) five-minute Apgar scores of seven or higher; (3) birthweight appropriate for gestational age. Each subject fell into one of four groups: (1) eleven subjects were preterms (PT) of gestational age ranging from 32 to 38 weeks (mean age 35 weeks); (2) eight subjects were full-term infants requiring Intensive Care Unit treatment (FT/ ICU) with an age range of 39 to 44 weeks (mean age 41 weeks); (3) seven of the subjects were full-term infants who were separated from their mothers after delivery because of the mother's illness (FT/ SM) with an age range of 39 to 42 weeks (mean age 40 weeks); (4) ten subjects were normal full-term infants (FT/ C) with an age range of 39 to 41 weeks (mean age 40 weeks).

Procedure

All infants were studied for the duration of their hospital stay for reasons of accessibility and uniformity of environmental conditions. Although the observation periods were originally scheduled to be 9 hours for one day per week, difficulties in accessibility

(e.g., feeding, visits, exams, etc.) reduced the mean length of observation per day to 7.5 hours (range: 4.0 to 8.7 hours).

During each observation period, observers (trained to at least 90% agreement) continuously recorded the infant's predominant state every 10 seconds. Interruptions (e.g., a hospital staff member or parent interacted with the infant) or time outs (e.g., the observer was temporarily unable to continue data collection) were also coded for and scored on the data sheet in sequence with the state data collected. During an interruption, observation was discontinued until 10 minutes after the interaction had terminated.

The state categories used in the study were measured by direct observation of the infant and are similar to those described by Thoman (1975a, 1975b). They include:

Quiet sleep. The infant's eyes are closed and still. There is little or no motor activity (i.e., no more than a startle or a slight movement of one limb).

Crying in sleep. The infant's eyes are closed and still. There is little or no motor activity but a cry burst occurs during the 10-second epoch.

Active sleep without REM. The infant's eyes are closed and still but motor activity is present.

REM sleep. The infant's eyes are closed (although they may be open briefly) and rapid eye movements occur during the 10-

second epoch. Motor activity may or may not be present.

Drowsy REM. The infant's eyes are partially open for a major part of the epoch; however, rapid eye movements are also present. Motor activity may or may not be present.

Drowsy. The infant's eyes may be partially open or fully open but dazed in appearance. Motor activity may or may not be present.

Alert inactivity. The infant's eyes are wide open, focused, bright, and shining (Wolff, 1967). Motor activity is usually absent, but may be present if it is involved with the infant's looking behavior (e.g., infant slowly moves hand across field of view while following with eyes).

Alert activity. The infant's eyes are open but not focused or "bright and shining." Motor activity is present.

Fussing. The infant's eyes may be open or closed, and motor activity is usually present. Mild, agitated vocalization (with up to one cry burst) is present.

Crying. The infant's eyes may be open or closed, and intense motor activity is present. Two or more cry bursts occur during the epoch.

The data were scored by assigning each of the ten states a number from zero to nine. Interrupts and time outs were recorded as eleven or twelve, respectively. So, for example, if the subject was

in the state of quiet sleep for the first ten seconds, a one was recorded in the first column. If the infant remained in the state of quiet sleep for the next ten seconds, a one was recorded in the second column. Should he have changed to another state in the third ten seconds (e.g., active sleep without REM), the numeral corresponding to the new state would be recorded in the third column, and so forth for the entire period of observation. This procedure resulted in a digit string (a data vector) which indicated what state the infant was in at a given time, how long he remained in that state, and in what sequence he changed states. This method of recording allowed for easy transference to computer cards for the subsequent data analysis by the program.

Analysis

Preliminary to writing the program, it was necessary to arrive at a set of rules and criteria for (a) defining a true instance of a state manifestation and (b) identifying a method of handling observations which are inconsistent with that definition of a state. Subsequently, the occurrence of a state was defined as being three consecutive ten-second periods that produce the same behavioral observation. Therefore, the minimum length of any state epoch was determined to be 30 seconds. Conversely, a single ten-second period producing one behavioral observation, or two consecutive ten-second periods with the same behavioral observation followed by a period with a different behavioral observation, were both construed as representing spurious fluctuations in state.

A set of five criteria were adopted as decision rules which, taken together, constitute a hierarchically structured rubric with which a data stream can be evaluated and random fluctuations in state eliminated. These five criteria consist of the following:

1. Perseveration - a drop out of state for one to three trials followed by a return to state for the same number of trials.

e.g., 33333453321 = 3333333321

2. Anticipation - a faltering entry into state; a run of one or two trials in the next state followed by one or two trials respectively of out-of-state trials before the state is entered.

e.g., 1233423333 = 123333333

3. 2/3 state with perseveration - the first incidence of two consecutive state observations in the transition field are found and then the field is checked for perseveration up to two trials long.

e.g., 33322324444 = 33322224444

4. 2/3 state with anticipation - the first incidence of two consecutive state observations is found and then the transition field is checked for one trial anticipation.

e.g., 333323224444 = 333322224444

5. Transition probabilities - absorption from either end of the transition field is accomplished based upon maximum transition probabilities.

e.g., 333122222 = 333322222

The decision rules are hierarchically implemented by the functioning program. Once a transition field has been identified (see below) the program attempts to close it by first evaluating the field to see if the leading state perseverates. If the perseveration rule is not applicable, and the transition field cannot be closed by anticipation into the following state, the program next attempts to redefine the field through 2/3 state with perseveration and then 2/3 state with anticipation. Finally, if after evaluating the transition field using the first four rules it is still not possible to form a clear cut transition between states, transition probabilities are used to evaluate the remaining out-of-state characters.

The program consists of two parts. The first part reads the raw data into the computer and calculates the summary characteristics of these data: state frequencies, percent observations in state, transition probabilities, and consecutive observations in state. The second part of the program (the smoothing routine) re-evaluates the raw data in terms of the five decision rules defined above and modifies any out-of-state characters in the process. Once the entire data vector has been redefined, the analysis is switched back to the first part of the program where the summary characteristics of the data vector are recomputed. This half of the program may itself be broken down into five separate segments: state interrupt, state continuation, anticipation, 2/3 state, and transition probabilities. Appendix A gives a complete deck listing of this half of the program along with comment statements to denote the five segments and explain important points in the program.

State Interrupt. The state interrupt segment is designed to perform two functions: (1) locate the first occurrence of a state on the data vector and (2) find the next occurrence of a state once a break in state is identified in the state continuation segment. To perform the first task, the data vector is checked one digit at a time until the first instance of three consecutive digits yielding the same observation is found. Such an instance is recognized as indicating a state. Once this initial state has been found, the state interrupt segment shifts the analysis over to the anticipation segment for evaluation of the field of out-of-state characters preceding the initial state. If no such field exists (i.e., the first three characters on the data vector form a state), the program branches immediately to the state continuation segment.

The second function—locating the next occurrence of a state once a break in state is identified—is handled in a similar fashion. A break in state occurs whenever a group of out-of-state characters succeed a group of in-state characters (a state) and they cannot be re-defined according to the perseveration rule. Starting at the last in-state character on the vector, the data is checked for the next instance of three consecutive digits that are the same. The program identifies these as representing the next state and the series of characters that exists between this state and the previous state are discerned as constituting a transition field. A transition field between states is handled in a like manner to a field of out-of-state characters that occurs prior to the first state. In both cases, the program

branches from the state interrupt segment to the anticipation segment for further evaluation. Two examples help clarify these points. The first example represents a series of characters at the beginning of a data vector:

2322321111...

The infant was assessed as being in state 2 (active sleep without REM) for the initial 10-second period, followed by 50 seconds during which he fluctuated between states 2 and 3 (REM sleep). The next four observations show a series of "1's" indicating that the infant switched states and remained in the new state for at least 40 seconds. As the program begins assessing this particular pattern, it would recognize that the first six observations do not constitute a state, as no three consecutive characters yield the same behavioral observation. Stepping further along the vector, a series of "1's" would be encountered and since there are three consecutive "1's," they would be recognized as comprising the first state. Because in this example there is also a field of out-of-state characters prior to the first state, the program branches to the anticipation segment.

The second example depicts two states separated by a series of out-of-state characters that comprise a transition field:

...11123121222...

Between state 1 (three consecutive "1's") and state 2 (three consecutive "2's") are a series of five characters that do not form a state. Once this transition field is encountered in the state continuation segment (to be discussed below) the program branches back to state in-

terrupt. Beginning with the first out-of-state character (the "2" that immediately follows the series of "1's"), the vector is checked for the next state. The program recognizes the series of "2's" as representative of the next state, and also that there is a transition field between this state and the last. Once again, the analysis is switched to the anticipation segment for redefining the out-of-state characters.

One special case is also handled in the state interrupt segment: an interrupt or a time out in the data vector. Interrupts or time outs represent pauses in the data collection. As such, they are treated as end points and the program essentially rewinds to the beginning as if the character immediately following an interrupt or a time out were the first character on a new data vector. Thus, after encountering an interrupt or a time out, the program branches back to the state interrupt segment and begins looking for the next state.

There are two possible places in relation to the data that time outs or interrupts can occur: prior to the first state, or between two states as part of a transition field. In both cases the program attempts to smooth any out-of-state characters surrounding the interrupt or time out by branching to the 2/3 state routine for analysis. If it is not possible to redefine the field using one of the 2/3 state rules, it is blanked out, replacing all of the out-of-state characters with "12's." Thus, these numbers are recorded as time outs by the program and do not enter into the final analysis of the smoothed data vector. (The 2/3 state rules are the only ones applicable under these circum-

stances. Normally, transition probabilities are used to close a field, but in this case they are not applicable. It makes no sense to talk of a transition from, for example, quiet sleep to an interrupt.) In practice these circumstances occurred infrequently and the loss of information was minimal.

State Continuation. Once the first state is found in the state interrupt segment and the field of out-of-state characters prior to the first state redefined by using either the anticipation rule or one of the 2/3 state rules (if such a field exists), the program shifts the analysis to the state continuation segment. In this portion of the program the data is checked for a break in state. As stated earlier, a break in state occurs whenever a group of out-of-state characters is encountered antecedent to a group of in-state characters and they cannot be redefined according to the perseveration rule. In the state continuation, the data vector is checked one character at a time until the first out-of-state character is encountered. Having found such an instance, the program attempts to redefine the out-of-state character using the perseveration rule. This rule is applicable when there is a break in state of one to three characters followed by a return to state for the same number of characters. An example of such an occurrence is:

...11112321111...

Here, the infant was recorded as being in state 1 for at least 40 seconds when in the next 30 seconds, 3 out-of-state characters were found. These out-of-state characters were then followed by a return to state 1 for the next 40 seconds. Accordingly, the program would first recog-

nize that the infant was in a state (three "1's" or 30 seconds) and that there had been a momentary fluctuation from that state (three out-of-state characters) followed by a return to the original state. Invoking the rule on perseveration, the program would redefine the out-of state characters so that this segment of the data vector would become:

...111111111111...

The program would then continue reading along the vector until the next out-of-state characters were found. One or two out-of-state characters would be handled in exactly the same way as in the example above, provided there is a return to state for the same number of characters. A break in state of more than three out-of-state characters or a failure to return to state for at least the same number of characters would cause the program to switch back to the state interrupt segment to locate the next state. The example below illustrates a case where the perseverative rule does not apply.

...444564335

In this example, the program would recognize a break in state of two characters (the "5" and the "6"). However, since these two characters are followed by only one in-state character (the "4") before another out-of-state character is encountered, the perseverative rule is not applicable. Therefore a transition field has been found and the next state is looked for in the state interrupt segment.

Besides checking for the applicability of the perseverative rule, the state continuation segment also handles one special case as

shown by the next example.

...111113333...

In this case, one state immediately follows another without any out-of-state characters intervening. Should such an instance occur, the program is able to ascertain that a new state has been immediately entered and simply continues reading along the vector at the beginning of the new state while affecting no alteration.

Anticipation. The anticipation segment of the program performs the functions of (a) smoothing a field of out-of-state characters occurring prior to the first instance of a state and (b) smoothing transition fields of out-of-state characters that occur between two states. The program operates similarly in both cases so that for the purpose of explaining the functioning of the anticipation segment, only the latter case will be examined.

As stated previously, once a transition field has been found, the program locates the next state by returning to the state interrupt segment. When this task is accomplished, the program attempts to re-define the out-of-state characters in the transition field by using the anticipation rule. In order to use anticipation as a way of re-defining a transition field, the field must consist of at least two characters. If there is only a one character transition field between two states:

...111132222...

the program skips over the anticipation segment and goes immediately

to transition probabilities for smoothing. When there are at least two characters comprising the transition field, the program attempts to re-define them by first using the anticipation rule.

Anticipation is simply the reverse of perseveration. Hence, the anticipation rule is implemented by the program as the reverse of the way the perseveration rule was implemented. Instead of stepping through the transition field looking for out-of-state characters followed by a return to in-state characters (as in the case in perseveration), the program steps backwards through the transition field looking for out-of-state characters preceded by in-state characters. This procedure is demonstrated by considering two examples:

...2223133333...

In this case there is a transition field of two characters between state 2 and state 3. Through the application of the anticipation rule, the program would recognize that the subject began to enter state 3 but faltered for a single 10-second period before finally entering state 3. The "1" would then be transformed to become a "3" and the smoothed data vector would become:

...2223333333...

The second example illustrates a two-character entry into state where the anticipation rule also applies:

...222211331111...

when smoothed, becomes:

...222211111111...

The possibility exists that the transition field cannot be smoothed according to the anticipation rule. This happens when there are no "anticipatory" in-state characters in the transition field:

...222231234444...

or there are not the same number of in-state characters preceding the out-of-state.

...22223423444...

In this example, a "4" exists in the transition field but there are two out-of-state characters between it and the first character of state 4, instead of one character. Therefore, this transition field and the one in the example immediately preceding it must be smoothed by using either one of the 2/3 state rules or transition probabilities. This type of transition field is evaluated for the number of out-of-state characters in it by the anticipation segment. If the transition field is at least four characters long, the program switches to the 2/3 state segment. If the transition field consists of three or fewer out-of-state characters, the program switches to the transition probabilities segment.

2/3 State. The 2/3 state segment of the program redefines the term state. Instead of meaning three consecutive observations that are the same, state is temporarily redefined to mean only two consecutive observations that are the same. With this new definition of state, the 2/3 state segment attempts to smooth the transition field by applying either perseveration or anticipation. This is accomplished as follows: Starting with the first out-of-state character in the transi-

tion field, the program looks for two consecutive digits that are the same. Once such an occurrence is found, it is treated as an instance of a state. The perseveration rule is then utilized in exactly the same way as it was in the state continuation segment except that instead of applying to a drop out of state for one to three trials, perseveration applied to a drop out of state for only one to two trials. The example below illustrates a case where the modified definitions of state and perseveration are applicable.

...2223313444...

The underlined portion of the segment represents a four-character transition field between state 2 and state 4. In the 2/3 state segment, the first two "3's" would be identified as constituting a state. After stepping forward through the transition field an out-of-state "1" would be encountered, followed immediately by an in-state "3." Since this satisfies the conditions for 2/3 state and perseveration, the "1" would become a "3" and the smoothed data vector would look like:

...2223333444...

The smoothed data vector now shows that after being in state 2 (active sleep without REM), the infant had a brief period in REM sleep (state 3) before finally changing to the state of drowsy REM; the effect of the smoothing procedure being the emergence of a clear transition pattern. In a straightforward fashion, the 2/3 state with anticipation rule is also implemented in this segment of the program. The first step is, again, finding two consecutive characters that are the same, and then checking for the applicability of the anticipation rule. The

anticipation rule is also modified to apply to one trial anticipation instead of two as it did in the anticipation segment. If, in the above example, the transition field had been:

...2223133444...

the program would have found the two "3's" and stepped backward through the transition field, finding that the conditions for one trial anticipation were met (one in-state character followed by one out-of-state character). The out-of-state "1" would then be smoothed so that the resultant data vector is exactly the same as the one modified by the implementation of the 2/3 state with perseveration rule.

...2223333444...

Transition Probabilities. If, after stepping through the transition field the program finds (a) an instance of two in-state characters but cannot apply perseveration or anticipation, or (b) no instances of two in-state characters, it goes to the transition probabilities segment. Transition probabilities, or, the likelihood of going from one state to another, is calculated for each subject in the initial part of the program. These probabilities are based on the raw data obtained during the observation period. As utilized in the smoothing portion of the program, the transition probabilities determine which characters will be absorbed and which will remain a part of the data vector. The segment of a data vector below presents an instance where the transition probabilities segment would be utilized.

...3333452222...

After being evaluated by the first four segments of the program, this

data vector still has a transition field of two characters. In the transition probabilities segment the program would compare whether it was more likely to go from state 3 to state 4, or from state 5 to state 2. Taking the former event to be more likely, the program would alter the transition field accordingly:

...33333422222...

retaining the more probable transition (from state 3 to state 4) and absorbing the less likely transition (from state 5 to state 2). Since the out-of-state character remains ("4") the process would be repeated and again, depending on the transition probabilities between states, the "4" would become either a "3" or a "2." The smoothed data vector would now be:

...3333322222...

Should the unlikely possibility arise that the transition probabilities for both of the compared transitions are exactly the same, the program has a perseverative bias. This bias is tantamount to considering an infant as remaining in a given state until making a clear transition to another state.

...1111234444...

To illustrate, assuming it was as likely for an infant to go from state 1 to state 2 as it was to go from state 3 to state 4, the "2" would be absorbed to become a "1." The above data vector would become:

...1111134444...

and the "3" would be evaluated according to the appropriate transition

probabilities. This process preserved the time spent in state 1 for at least one more observational period as there was no clear indication that a transition to another state was made.

Once a transition field has been completely smoothed, the program has run full cycle and goes back to the beginning segment (state interrupt). It then starts at the first character of the smoothed transition field and looks for the next state. The five segments of the smoothing portion of the program operate interdependently, switching from one segment to another contingent upon the conditions encountered in the analysis of a given data vector. The organization of the program can be shown pictorially and discursively. Appendix B is a flow chart of the logic used (series of decision procedures) by the functioning program to evaluate the infant state data. This flow chart depicts schematically, the organization of the program and the specific steps used for assessing and redefining the raw data. Also made explicit are the interconnections between segments of the program and the conditions under which one portion of the program switches to another. Second, a discussion of a transition field that requires evaluation by all five segments of the program in order to be completely smoothed will be presented and analyzed step by step as it would be by the program. The following portion of a data vector contains just such a transition field:

...333232232432332322...

It appears that the infant is going from state 3 to state 2, but in a "noisy" fashion. Thus there exists a transition field of thirteen out-

of-state characters between state 3 and state 2. As a first step, the program would (in the state interrupt segment) identify that there was an instance of a state (three "3's" on the data vector). After finding this state the program would switch to the state continuation segment and begin evaluating the vector for out-of-state characters and the applicability of the perseverative rule. Since the next character on the vector is an out-of-state "2" followed by an in-state "3," the perseverative rule does apply and the "2" would be smoothed over to become a "3."

...333322324323323222...

Remaining in the state continuation segment after applying the perseverative rule, the program continues moving along the data vector until the next out-of-state character is encountered. In the example, this occurs where there are two "2's" following the string of in-state "3's." This time the perseveration rule is not applicable (i.e., when there is a two- or a three-character break in state there must be a return to state for the same number of characters). Since a break in state has been identified that cannot be smoothed over using perseveration, the program returns to the state interrupt segment and begins looking for the next instance of a state. The three "2's" at the end of the data vector mark the next state. After this state has been identified, the size of the transition field is evaluated for the possibility of applying the anticipation rule. (As stated before, the transition field must be at least four characters long to make use of the 2/3 state or a minimum of two characters to make use of anticipa-

tion.) In this example the transition field is long enough to be evaluated for anticipation and the program shifts to the anticipation segment. Stepping backwards through the transition field from the first of the three in-state "2's," a case where anticipation applies is found. One out-of-state "3" is preceded by one in-state "2." Subsequently, the "3" is smoothed to become a "2."

...333322324323322222....

Again the transition field is evaluated for the applicability of anticipation since its size is appropriate. The anticipation rule does not apply, however, because the two out-of-state "3's" that are next encountered are preceded by only one in-state "2." The program then goes to the 2/3 state segment.

The 2/3 state segment begins with the first character of the transition field and looks for the first instance of two consecutive digits that are the same. These two characters are then treated as comprising a state. In the example, the two "2's" immediately following the string of five "3's" comprises such an instance. The transition field is then evaluated for the possibility of perseveration. Because the two "2's" (2/3 state) are followed by a "3" and another "2" in that order, the 2/3 state with perseveration rule applies (one out-of-state character followed by one in-state character). The out-of-state "3" is smoothed.

...333322222432332222...

The program is written so that once this change is made in the transition field, it returns to the anticipation segment and checks for

the possibility of anticipation into the newly formed state. Anticipation does not apply in this case because the four "2's" immediately follow five "3's." Starting with the first in-state "2," the program goes to the state continuation segment and begins looking for the next out-of-state character. The "4" in the center of the data vector marks a break in state that cannot be smoothed by perseveration, so the analysis is switched to the state interrupt segment to find the next state. The four "2's" at the end of the data vector are again found as the next occurrence of a state and, following the pattern already noted, the transition field is evaluated for the applicability of anticipation, 2/3 state with perseveration, 2/3 state with anticipation, in that order. Only the latter rule is applicable this time by the following logic. The transition field now consists of five characters:

...43233...

The first manifestation of 2/3 state is the two "3's" at the end of the transition field. Because they occur at the end of the transition field, perseveration cannot be applied. But, 2/3 state with anticipation does apply as the two "3's" are immediately preceded by a "3" and a "2." The "2" can now be smoothed to become a "3" and the transition field has been narrowed to one character, the "4."

...333332222433332222...

As when the 2/3 state with perseveration rule was applied to the data, the program returns to the anticipation segment and evaluates the transition field for the possibility of anticipation into the newly formed state. This time there is only a one character transition field

and closure by anticipation is not a possibility. As this field is not flanked by an interrupt or a time out (an "11" or "12," respectively), the program switches to the transition probabilities segment. In this segment the "4" is evaluated against the pertinent transition probabilities and becomes either a "2" or a "3," depending on which case is the more likely transition. This segment of the data vector has now been completely smoothed and evaluated, and in its final form looks like this:

...333332222333332222...

which, when compared to the original data vector:

...333232232432332322...

exhibits a clearly ascertainable pattern in the infant's behavior. The entire data vector is evaluated in this manner. Brief, random transitions between states are largely eliminated according to the implementation of the five decision rules, resulting in a less variable transition pattern.

RESULTS

The effects of using the program described above on infant state data is demonstrated with a printout for one of the subjects used in the study (Figure 1). The first page of the figure lists the summary characteristics of the raw data. The second and third pages of Figure 1 give the same set of summary characteristics for the smoothed data. In addition, a table of the "consecutive observations in state" and a listing of the subsequent "smoothed data stream" are included in the description of the smoothed data. These latter two segments of the printout are discussed in more detail below.

The summary characteristics of the raw data included in the printout for all subjects, as illustrated in Figure 1, were included to allow comparison with the smoothed data and to present the experimenter with an easily accessible summary of the raw data. For each set of observations, a set of identifying criteria are printed. These criteria include a subject number, time of day during which the observations were made, and the gestational age in weeks of the subject. In Figure 1, the data set is identified as representing subject number 3, at a gestational age of 37 weeks, during observation period number 3 (evening). These labels are printed above the corresponding set of smoothed data.

Immediately following the identification information, the four

Figure 1. A sample printout for one subject.

SUBJECT NO. 3											TIME OF DAY 3		GEST. AGE (WK) 37	
STATE FREQUENCIES														
STATE	0	1	2	3	4	5	6	7	8	9	INTERVENTIONS	TIMPOUTS		
	2	444	106	182	30	102	78	63	33	12	1	0		
PERCENT OBSERVATIONS IN STATE														
STATE	0	1	2	3	4	5	6	7	8	9				
	0.19	42.37	10.11	17.37	2.86	9.73	7.06	6.01	3.15	1.15				
TRANSITION FREQUENCIES														
02/01	0	1	2	3	4	5	6	7	8	9	INTERVENTIONS	TIMPOUTS		
0	0	0	0	0	2	5	0	0	0	0	0	0		
1	0	0	23	59	6	0	1	0	0	1	0	0		
2	0	34	64	19	0	0	0	0	0	1	0	0		
3	0	21	13	103	0	5	1	0	1	1	0	0		
4	0	65	3	1	0	8	5	0	2	1	0	0		
5	0	1	0	0	3	16	14	0	0	0	0	0		
6	0	0	0	0	0	0	40	1	0	0	0	0		
7	0	0	0	0	0	0	1	12	2	0	0	0		
8	0	0	0	0	0	0	0	14	10	0	0	0		
9	0	0	0	0	0	0	0	15	1	0	0	0		
INTERVENTIONS	0	0	0	0	0	0	0	0	0	0	0	0		
TIMPOUTS	0	0	0	0	0	0	0	0	0	0	0	0		
TRANSITION PROBABILITIES														
02/01	0	1	2	3	4	5	6	7	8	9				
0	0.00	0.00	0.00	0.00	6.67	0.00	0.00	0.00	0.00	0.00	0.00	0.00		
1	0.00	0.00	78.73	21.70	12.42	20.00	0.00	1.37	0.00	0.00	0.00	8.33		
2	0.00	0.00	0.00	69.38	19.44	0.00	0.00	0.00	0.00	3.03	0.00	8.33		
3	0.00	0.00	14.64	12.26	16.54	0.00	0.00	0.00	0.00	0.00	0.00	8.33		
4	0.00	5.00	0.00	2.83	0.00	10.00	0.00	6.85	0.00	1.59	0.00	8.33		
5	0.00	0.23	0.00	0.00	0.00	10.00	0.00	79.41	19.18	1.24	0.00	8.00		
6	0.00	0.00	0.00	0.00	0.00	13.33	0.00	15.64	54.79	19.05	0.00	8.00		
7	0.00	0.00	0.00	0.00	0.00	20.00	0.00	17.81	17.81	53.97	0.00	8.00		
8	0.00	0.00	0.00	0.00	0.00	0.00	0.00	0.00	23.81	37.39	0.00	8.00		
9	0.00	0.00	0.23	2.83	0.00	0.00	0.00	0.00	0.00	0.00	0.00	6.67		

Figure 1. Continued.

7	0	2	0	0	1	0	0	0	1	0
8	0	0	1	1	0	0	0	1	1	0
9	0	1	2	0	0	1	0	0	0	0
10	0	0	0	0	0	0	1	0	0	0
11	0	0	0	0	0	0	1	0	0	0
12	0	0	1	0	0	0	0	1	0	0
13	0	0	0	1	0	1	0	0	0	0
14	0	2	0	0	0	0	0	0	0	0
15	0	2	0	0	0	0	0	0	0	1
16	0	0	0	0	0	0	0	1	0	0
17	0	0	1	1	0	0	1	0	0	0
18	0	0	0	1	0	0	0	0	0	0

24	0	0	0	2	0	0	0	0	0	0

29	0	0	0	0	0	0	1	0	0	0
30	0	0	0	1	0	0	0	0	0	0

33	0	2	0	0	0	1	0	1	0	0

37	0	0	0	0	0	1	0	0	0	0

40	0	0	1	0	0	0	0	0	0	0

151	0	1	0	0	0	0	0	0	0	0

168	0	1	0	0	0	0	0	0	0	0
MEAN	0.00	30.21	11.10	16.00	5.25	19.40	14.40	12.83	5.20	10.50
STD DEV	0.0	52.0	10.5	8.5	1.1	13.0	8.2	10.0	2.0	4.5
SAMPLE N	0.00	10.00	10.00	9.00	4.00	5.00	5.00	6.00	5.00	2.00

SMOOTHED DATA STRIP

151* 1---	17* 3---	14* 1---	5* 3---	5* 2---	19* 3---	3* 2---	5* 1---	17* 2---	24* 3---
40* 2---	5* 1---	12* 2---	11* 6---	1* 10---	37* 5---	4* 4---	9* 5---	5* 6---	4* 4---
17* 6---	5* 5---	29* 6---	11* 7---	3* 8---	16* 7---	33* 5---	10* 6---	12* 7---	5* 8---
5* 7---	7* 4---	7* 4---	8* 8---	8* 7---	33* 1---	9* 2---	3* 8---	6* 4---	13* 5---
7* 1---	4* 2---	6* 0---	3* 7---	18* 1---	15* 4---	9* 1---	8* 2---	15* 1---	9* 2---
4* 1---	8* 3---	33* 1---	11* 3---	15* 1---	24* 3---	7* 1---	30* 3---	4* 1---	8* 2---
168* 1---	0* 0---								

Figure 1. Continued.

SUBJECT NO. 3 TIME OF DAY 3 GPST. AGE (WK) 37

STATE FREQUENCIES

STATE	0	1	2	3	4	5	6	7	8	9	INTERVENTIONS	TIMEPOINTS
	0	478	111	144	21	97	72	77	26	21	1	0

PERCENT OBSERVATIONS IN STATE

STATE	0	1	2	3	4	5	6	7	8	9
	0.00	45.65	10.60	13.75	2.01	9.26	6.88	7.35	2.48	2.01

TRANSITION FREQUENCIES

02/01	0	1	2	3	4	5	6	7	8	9	INTERVENTIONS	TIMEPOINTS
0	0	0	0	0	0	0	0	0	0	0	0	0
1	0	465	4	5	0	1	0	2	0	0	0	1
2	0	6	101	4	0	0	0	0	0	0	0	0
3	0	0	3	135	0	0	0	0	0	0	0	0
4	0	0	0	0	17	1	1	0	2	0	0	0
5	0	0	0	0	2	92	1	1	0	0	0	1
6	0	0	1	0	1	3	67	0	0	0	0	0
7	0	0	0	0	0	0	0	71	3	1	0	0
8	0	0	1	0	1	0	0	3	21	0	0	0
9	0	1	1	0	0	0	0	0	0	19	0	0
INTERVENTIONS	0	0	0	0	0	0	1	0	0	0	0	0
TIMEPOINTS	0	0	0	0	0	0	0	0	0	0	0	0

TRANSITION PROBABILITIES

02/01	0	1	2	3	4	5	6	7	8	9
0	0	0.00	0.00	0.00	0.00	0.00	0.00	0.00	0.00	0.00
1	99.99	97.28	3.60	3.47	0.00	1.03	0.00	2.60	0.00	4.76
2	99.99	1.26	90.99	2.78	0.00	0.00	0.00	0.00	0.00	0.00
3	99.99	1.26	2.70	93.75	0.00	0.00	0.00	0.00	0.00	0.00
4	99.99	0.00	0.00	0.00	90.95	1.03	1.41	0.00	7.69	0.00
5	99.99	0.00	0.00	0.00	9.52	94.85	1.41	1.30	0.00	0.00
6	99.99	0.00	0.00	0.00	4.76	3.09	94.37	0.00	0.00	0.00
7	99.99	0.00	0.00	0.00	0.00	0.00	2.82	92.21	11.54	4.76
8	99.99	0.00	0.00	0.00	4.76	0.00	0.00	3.90	80.77	0.00
9	99.99	0.21	0.90	0.00	0.00	0.00	0.00	0.00	0.00	90.48

CONSECUTIVE OBSERVATIONS IN STATE

STATE	0	1	2	3	4	5	6	7	8	9

3	0	0	1	0	0	0	0	1	2	0
4	0	2	2	0	2	0	0	0	0	0
5	0	1	1	2	0	1	1	1	1	0
6	0	0	0	0	1	0	0	0	0	1

summary characteristics computed by the program are presented for both the raw and the smoothed data: state frequencies, percent observations in state, transition frequencies, and transition probabilities. State frequencies shows the absolute number of observations for each state in a given recording session. From the data in Figure 1, it is evident that subject 3, during this particular observation period, spent the most time in state 1 and, to a lesser extent, state 3. Percent observations in state also demonstrates this point. Comparing these data with the results printed in the smoothed data portion of the figure, it becomes clear that the net result of the program was to increase the frequency for state 1, largely at the expense of state 3. The other eight states were affected only marginally with minor differences between the two data sets. These results have the following interpretation: while the subject was in the state of quiet sleep (state 1), he would momentarily change to REM sleep for, at most, 20-second bursts, before returning to the state of quiet sleep. Because these transitions were brief and erratic, they were assessed by the program as spurious and were redefined as indicating the infant remained in quiet sleep. The short bursts of REM activity present throughout the state of quiet sleep were not long enough or consistent enough to constitute a state of REM sleep.

Of particular interest for an analysis of the program's effects are the left-to-right diagonals in the transition frequencies and transition probabilities matrices. The numbers comprising these diagonals indicate the tendency of an infant to remain in a given state once he

has entered that state. In the transition frequencies matrix these numbers show the absolute number of times a state to same-state transition occurred between consecutive 10-second periods. In the transition probabilities matrix these numbers are converted into percentages indicating the probability that an infant would remain in a given state during the next period.

The expected outcome after analyzing the data with the program would be an increase in the probability of remaining in the same state as opposed to switching to another state. Thus, the numbers on the diagonals of both the transition frequencies and transition probabilities matrices for the smoothed data should be larger than the corresponding numbers on the raw data matrices. Inspection of the two sets of diagonals presented in Figure 1 yields the expected results. For each state, the probability of a state to same-state transition increased after the data were analyzed by the program. This result illustrates the essentially conservative nature of the rubric used to determine the program: once an infant is in a given state, he must clearly change to another state before a transition is scored.

The final two portions of the printout, "consecutive observations in state" and "smoothed data stream," allow for description and reproduction of the smoothed data vector. The "consecutive observations in state" table lists the epoch lengths recorded for each state during the entire observation period. The size of the epoch (number of consecutive observation periods yielding the same state observation)

is given in the first column. Each row of numbers gives a breakdown of how many epochs of size n occurred for each state. Where there are no epochs of size n recorded (e.g., there was no observed epoch of 4 characters in length but there were epochs of 3 and 5 characters in length for some of the states), a set of asterisks is placed by the program in the appropriate spot in the first column.

The table in Figure 1 shows that subject number 3 had epochs ranging from 3 characters in length (the minimum epoch length allowable by the program) to 168 characters in length (in state 1). Immediately below the table the mean, standard deviation, and number of epochs are given for each state. In the example, the mean epoch length for state 1 was 34.21 characters (approximately 6 minutes). The variable of epoch length described in this table is a product of the analysis by the program. In the raw data there would have been too many epoch lengths of 1 or 2 characters (10 to 20 seconds) to allow for a meaningful interpretation of the epoch variable. With the program as a statistical aid it becomes possible to look at the state variable in this additional way.

The "smoothed data stream" table allows for a complete character-by-character reproduction of the smoothed data. The researcher, in order to assess the effects of the program in detail, may compare the smoothed data stream with the raw data input. A portion of such a comparison is reproduced in Figure 2 for the subject whose data is presented in Figure 1. The first eleven character columns in each row are identification data giving the subject number, gestational age in

ID

DATA

032134737 33311113111113333333331133333131121322111113133333222113333333311313333 (raw)
032134737 31111111111133333333333333331111111111111333332222333333333333333333 (smoothed)

CARD 3

032134737 211133111111113131 (raw)
032134737 211 (smoothed)

CARD 2

032134737 11111111111311111111111111111111111111111111223111111111111111111111 (raw)
032134737 111 (smoothed)

CARD 1

Figure 2. A comparison between a raw and a smoothed data stream.

weeks, time of day, and card number. The remaining characters comprise the data stream. The raw data stream shows that for the first two rows of data the subject was mainly in state 1 (quiet sleep), with some very short transitions into state 2 (active sleep without REM) and state 3 (REM sleep). These short transitions were absorbed by the program through the application of the perseveration rule to reveal that the subject was in a sustained epoch in state 1. Not until the third row of characters is there a clear transition from state 1 to state 3. The third row also illustrates the gradual transition from state 3 to state 2 to an extended epoch in state 3. Again, the patterning of the transitions emerges more clearly in the smoothed data than in the raw.

A two-way repeated measures analysis of variance was done on the data to determine whether there were any reliable differences in proportions of time spent in a given state produced by the rubric. It was also of interest to discern whether any such differences might occur differentially as a function of group membership. Because the length of an observation period varied between infants, percent observations in state were used as opposed to absolute frequency of observations. This procedure was followed to correct for the possibility that the frequency of observations reflected the length of the observation period as well as the tendency of the infant to manifest a particular state behavior. The comparison between the raw and the smoothed data represented the within-subject variable and groups made up the between-subject variable. Though only 36 babies provided data for the analysis, most were observed on several occasions, yielding a total of 113 cases.

Each case was treated as an independent observation in the analysis. Separate analyses were done for each state. The results of these analyses are presented in Table 2. Group means for both raw and smoothed data are presented in Table 3. The results of the analysis can be conveniently discussed by considering the separate results obtained for each state:

Quiet sleep. This state produced the greatest proportion of observations for all groups in both the raw and the smoothed data. A highly significant effect from the program's analysis was obtained ($F(1,109) = 60.65, p < .01$). The total proportion of observations in quiet sleep was increased for all groups after analysis by the program. These added observations may be accounted for by the decrease in observations in crying sleep and in active sleep without REM.

Crying in sleep. The infants who were separated from their mothers because of their mother's illness (FT/ SM) spent a strikingly longer time crying in sleep than the infants in the other three groups ($F(3,109) = 6.15, p < .01$). The program unilaterally decreased the scores for all groups but because the numbers were so low, a basement effect occurred and this effect did not quite reach significance ($F(1,109) = 3.80, p = .05$).

Active sleep without REM. Both of the independent variables and their interaction had statistically significant effects

Table 2
Analyses of Variance

State	Source	<u>df</u>	<u>MS</u>	<u>F</u>
Quiet Sleep	Group (G)	3	0.05182	1.17
	Error _b	109	0.04436	
	Prepost (P)	1	0.03179	50.65**
	P x G	3	0.00042	0.67
	Error _w	109	0.00063	
Crying in Sleep	Group (G)	3	0.00967	6.15**
	Error _b	109	0.00157	
	Prepost (P)	1	0.00008	3.80
	P x G	3	0.00001	0.32
	Error _w	109	0.00002	
Active Sleep without REM	Group (G)	3	0.03336	7.30**
	Error _b	109	0.00457	
	Prepost (P)	1	0.03223	166.52**
	P x G	3	0.00144	7.45**
	Error _w	109	0.00019	
REM Sleep	Group (G)	3	0.03091	1.11
	Error _b	109	0.02772	
	Prepost (P)	1	0.00126	1.72
	P x G	3	0.00080	1.08
	Error _w	109	0.00074	

Table 2
(Continued)

State	Source	<u>df</u>	<u>MS</u>	<u>F</u>
Drowsy REM	Group (G)	3	0.00036	1.15
	Error _b	109	0.00031	
	Prepost (P)	1	0.00085	24.87**
	P x G	3	0.00006	1.73
	Error _w	109	0.00003	
Drowsy	Group (G)	3	0.00927	0.93
	Error _b	109	0.00994	
	Prepost (P)	1	0.00032	2.60
	P x G	3	0.00016	1.32
	Error _w	109	0.00012	
Alert Inactivity	Group (G)	3	0.00197	0.29
	Error _b	109	0.00683	
	Prepost (P)	1	0.00003	1.04
	P x G	3	0.00003	0.94
	Error _w	109	0.00003	
Alert Activity	Group (G)	3	0.00108	1.05
	Error _b	109	0.00103	
	Prepost (P)	1	0.00055	24.07**
	P x G	3	0.00001	0.51
	Error _w	109	0.00002	

Table 2
(Continued)

State	Source	<u>df</u>	<u>MS</u>	<u>F</u>
Fussing	Group (G)	3	0.00245	0.69
	Error _b	109	0.00355	
	Prepost (P)	1	0.00009	1.45
	P x G	3	0.00025	4.10**
	Error _w	109	0.00006	
Crying	Group (G)	3	0.03885	5.37**
	Error _b	109	0.00723	
	Prepost (P)	1	0.00060	13.25**
	P x G	3	0.00024	5.29**
	Error	109	0.00005	

**p < .01.

Table 3
Group Means for Raw
and Smoothed Data^a

State	Data	Group ^b			
		1	2	3	4
Quiet Sleep	Raw	0.5153	0.5354	0.4364	0.4913
	Smoothed	0.5397	0.5569	0.4649	0.5255
Crying in Sleep	Raw	0.0046	0.0038	0.0415	0.0180
	Smoothed	0.0031	0.0033	0.0389	0.0172
Active Sleep without REM	Raw	0.1096	0.0632	0.0993	0.0845
	Smoothed	0.0948	0.0395	0.0623	0.0505
REM Sleep	Raw	0.2267	0.2110	0.1944	0.2593
	Smoothed	0.2227	0.2222	0.2019	0.2663
Drowsy REM	Raw	0.0127	0.0131	0.0633	0.0107
	Smoothed	0.0063	0.0070	0.0320	0.0056
Drowsy	Raw	0.0584	0.0634	0.0659	0.0379
	Smoothed	0.0605	0.0637	0.0756	0.0368
Alert Inactivity	Raw	0.0402	0.0476	0.0296	0.0397
	Smoothed	0.0408	0.0467	0.0261	0.0401

Table 3
(Continued)

State	Data	Group ^b			
		1	2	3	4
Alert Activity	Raw	0.0126	0.0186	0.0202	0.0087
	Smoothed	0.0102	0.0143	0.0159	0.0053
Fussing	Raw	0.0135	0.0270	0.0303	0.0186
	Smoothed	0.0168	0.0278	0.0255	0.0135
Crying	Raw	0.0059	0.0166	0.0758	0.0351
	Smoothed	0.0045	0.0182	0.0853	0.0403

^aGroup Means = proportion of total observations in state

^bGroup 1 = Preterms

Group 2 = Full Term/ ICU

Group 3 = Full Term/ Sick Mother

Group 4 = Full Term/ Control

on this dependent variable. The effect of "groups" ($F(1,109) = 7.30, p < .01$) is attributable to the relatively large proportion of time the preterms (group 1) spent in this state and the relatively small amount of time the full-term/ ICU infants (group 2) were in this state. The program analysis was also significant ($F(1,109) = 166.52, p < .01$) because of the large reduction in proportions for all of the groups. Combining this result with the overall increase in total number of observations in quiet sleep, it can be surmised that active sleep without REM was manifested sporadically within the quiet sleep epochs. Consequently, these observations were absorbed into the state of quiet sleep along with the drowsy REM observations that were also reduced by the program. Finally, a highly significant interaction effect was found ($F(3,109) = 7.45, p < .01$). Although the program analysis altered the data in the same direction for all groups, the reduction was comparatively smaller for the preterms than for the other three groups.

REM sleep. No significant effects were recorded for this state as the number of observations was stable across groups and data records. The preterms and the FT /C infants in group 4 tended to spend greater amounts of time in this state, but the variability was large enough to prevent this difference from being a significant one. No trend is discernible from the data analysis; scores neither increased nor decreased in any sort of pattern.

Drowsy REM. Overall, few observations were recorded for this state, as borne out by the mean proportion of total observations across all groups ($\bar{x} = .008$). Highly significant results were obtained due to the program analysis ($F(1,109) = 24.87$, $p < .01$). The mean scores for this state in Table 3 identify this effect as a general decrease in the number of observations for all groups. As discussed earlier, this reduction of number of observations in a particular state means that the lost occurrences were sporadic and thus not indicative of stable behavioral patterns.

Drowsy. No significant effects were obtained for this state. The cell means across groups and program analysis were stable, with the FT/ C infants showing a tendency towards spending less time in this state than the other infants.

Alert inactivity. This state was also stable as a measure of infant behavior across groups and program analysis; no significant effects were recorded. Examination of the cell means show that the infants in group 3 (FT/ SM) tended to spend less time in this state than the other infants.

Alert activity. The program analysis had a statistically large effect on the data for this state ($F(1,109) = 24.07$, $p < .01$), although numerically this translated into a small reduction in proportion of observations in this state ($\bar{x} = .003$). The reason that this effect reached significance was that there were

few observations recorded in this state across all of the groups with the net mean proportion of observations being .012. These findings indicate that newborn infants do not spend a great deal of time in alert motor activity. The effect of the program is to underline this finding by further removing those occurrences of the alert active state which did not last for at least 30 seconds.

Fussing. A significant interaction effect occurred between the independent variables in this state ($F(1,109) = p < .01$). Inspection of the mean scores shows that for the PTs (group 1) and the FT/ ICU infants (group 2), the program increased the average proportion of observations while the opposite effect, a decrease, resulted for the FT/ SM and the FT/ ICU. Thus, the fact that there was virtually no change across groups in the proportion of observations per session, is explained by the two sets of opposite effects balancing each other out.

Crying. Both of the independent variables and their interaction produced significant results. The group effect was caused by the relatively large amount of time infants in groups 3 and 4 (FT/ SM and FT/ C) spent crying, compared to the other two groups of infants ($F(3,109) = 5.37, p < .01$). The preterms in particular manifested very little crying behavior (mean proportion of observations = .004). Analysis by the program resulted in an increase in the number of observations of crying for all

of the groups, with the exception of the preterms where there was a slight decrease ($F(1,109) = 13.25, p < .01$). The decrease for the preterms and a small increase for the FT/ ICU infants (group 2) caused an interaction effect. The interaction served to sharpen the intergroup distinctions that were already present in the raw data.

DISCUSSION

The purpose of the rubric that was used to determine the program presented in this paper was primarily the reduction of spurious transitions between states, thereby decreasing extraneous variability in the data. It was also hypothesized that by removing erratic occurrences of state behavior, the program could also perform the secondary task of refining state taxonomy by sharpening the categories of state behavior. During the course of the study, a third possibility presented itself, that being the creation of a new variable for measuring infant behavior based on the pattern of state transitions—epoch length. These three functions serve as a framework for a discussion of the results of the present study, as there is evidence that the implementation of the rubric through the program accomplished these tasks.

Taxonomic Refinement

In the argument presented in the introduction, the two approaches of defining state were discussed and it was concluded that the soundest of the two was to define a state operationally as representative of discrete clusters of behavior. The tactic of defining state as lying on a continuum of lesser to greater levels of arousal was seen as confounding the concept of state with another concept (arousal) whose definition was ambiguous, especially with regards to responsiveness to stimulation. Given these considerations, the challenge of refining state taxonomy lies in finding categories that are identifiably dis-

crete. In this instance, "discrete" refers to the attributes of distinguishability, stability, and temporality.

In order to satisfy the criteria for being termed a state, a group of behaviors should first be distinguishable as a separate entity from other groupings of behaviors in an infant's repertoire. One state, then, should be identifiably distinct from another in that it is manifested without an admixture of other behaviors from different states. Second, the group of behaviors, or state, should turn up repetitively over a period of time so that the grouping has a stability to it. This second attribute may be thought of in terms of the reliability criterion. Finally, a state should be manifested for some duration of time so that it is not merely a random event or an event without significance to the organization of the infant's behavior. This is the attribute of temporality that should exist despite the "volatile nature" of infants. Thus, a group of behaviors that comprise a separate state represent a qualitatively distinct entity manifested over time that is significant with respect to the organization of an infant's behavior, and hence significant also in terms of infant development.

The taxonomic classification of infant states is therefore concerned with finding groupings of behavior that satisfy these criteria. In the sleep states, where classification has been particularly difficult, it has been usually attributable to the poor distinguishability and stability of the groupings. In the present study, the results from the data analyses suggest how the program might be useful in this re-

spect as exemplified by the results obtained for the state of drowsy REM.

The state of drowsy REM was observed very infrequently overall as indicated by the raw data so that, to begin with, there was infrequency of occurrence. The results from the analyses of variance showed that the program consistently reduced the already small number of observations, indicating that the manifestations of this state were both brief and erratic. Therefore, the indications of these results is that the grouping or behaviors identified as comprising the state of drowsy REM were not manifested for an appreciable duration, nor did the manifestations that did occur have much stability; thus, they were absorbed into other states. It is dubious, given these considerations, that drowsy REM is an important way of categorizing infant behavior. The raw data suggested this conclusion, the program results underlined it.

This finding alone is not sufficient for completely eliminating drowsy REM from taxonomic schemes. Further research is warranted. One could visualize the situation whereby a particular state category increased in stability and frequency as the infants matured (cf. Spitz et al. 1970; Berg & Berg, 1979). It is also possible that a group of infants not studied in the present research manifests the state of drowsy REM quite regularly, in which case it may prove to be a diagnostically reliable way of classifying these infants. Nevertheless, the present results demonstrate how the smoothing program might be useful as a tool for taxonomic refinement.

It would be especially informative to analyze data gathered using different systems of classification. For example, Thoman's (1975a, 1975b) proposed subdivisions of the state of quiet sleep and active sleep would be given additional weight once evaluated by the program. While her research provided some justification for the proposed subdivisions, an analysis by the smoothing program would show whether or not these states were appreciably distinguishable from one another and hence whether or not they described separate infant states. This would be apparent if the occurrences of one subdivision were not absorbed into another subdivision upon analysis. One could then conclude whether active sleep with dense REM was qualitatively different from active sleep with REM.

Reduction of Extraneous Variability

The variability arising from brief, erratic transitions between states has been assumed here to be attributable to behavioral instability that results in spurious changes in states that do not reflect real transitions. Where behavioral observation is employed, some of these instances might also be caused by fluctuations in observer attentiveness. In past research that used the state variable, these momentary passages from one state to another were scored as transitions and included in the data analysis (cf. Thoman, 1975a). It follows that if these transitions are really not transitions at all, but merely momentary fluctuations that add noise to the data, the transition probabilities computed on these data are inaccurate; specifically, they are too high.

The present study demonstrates how the transition probabilities in the raw data are reduced by the program. It has been shown that the diagonals in the transition probabilities matrices are altered to maximize the probabilities of state to same-state transitions. Thus, the probability of remaining in state is enhanced by the program. The maximization of these probabilities, which forces a clean transition between states before it is scored as such, directly effects the other transition probabilities in the matrices; they are reduced because of the eradication of spurious transitions. An example from the data will clarify this point.

In the analyses of variance the number of observations of quiet sleep were significantly increased for all groups. This result was accompanied by corresponding reductions in the states of drowsy REM and active sleep without REM. It was then suggested that the observations that were lost by the latter two states were absorbed into the state of quiet sleep, accounting for the resultant increase. The transition probabilities matrix in the sample reproduction of one subject's print-out (Figure 1) reflect these changes. In the transition probabilities matrix shown in Figure 1 for the raw data, the active sleep without REM to quiet sleep transition probability was 21.70% (meaning that approximately one-fifth of the transitions scored for active sleep without REM were to quiet sleep). After the data were analyzed by the program this same transition probability was reduced to only 3.60%. A similar but smaller reduction in the probabilities for the reverse transition from quiet sleep to active sleep without REM indicates a reciprocal effect (4.73% to 1.26%).

It is a corollary of the main thesis of this study (that momentary fluctuations in state do not represent true transitions or transition patterns) that the transition probabilities based on the smoothed data stream more accurately represent the likelihood of an infant switching from one state to another, rather than the probabilities based on the raw data. In the present study the maximization of the diagonal elements of the transition probabilities matrices effected reductions in the other transition probabilities lying off the diagonal. The indication from the present research is that infants do not switch states as frequently as they have been assessed as doing in previous research. These results again point to the conservative bias of the rubric which requires a clear break in state for a transition to be scored.

It should be mentioned here that in constructing the rubric and subsequently the program so that brief occurrences of one state are absorbed into another, the existence of these brief fluctuations is not being ignored or denied. Nor is the fact that erratic, unstable behavior in infants might be prognostically valuable (cf. Thoman, 1975b). On the contrary, the program highlights erratic behavior so that even when there is no overall difference quantitatively in the raw data, the smoothed data reflect this attribute; there is a reduction in number of observations into another state. The great advantage of removing the erratic transitions is that the patterning of state behavior is much more obvious. Both the hypothetical example at the conclusion of the methods section and the partial reproduction of a raw and

smoothed data stream (Figure 2) were presented to illustrate this point.

In this respect, the program operates analogously to the programs used as aids to weather forecasting and space exploration. These programs create "computer enhancements" of satellite photos so that weather patterns and trends or photographs taken in space are given greater resolution. In a like fashion, the smoothing program creates an enhancement of infant state data so that transitions between states are highlighted. The enhancement effect of transition patterns occurs because unlike other procedures that employ averaging over intervals (cf. Theorell et al. 1973), the 30-second intervals are analyzed in context with contiguous intervals to account for trends in the data reflective of trends and patterns in behavior.

Evidence that the program was having this type of an effect can also be determined (in addition to the evidence shown in Figure 2) by further examination of the results of the analyses of variance. The specific results already cited above can be used to support the reduction of extraneous variability and pattern enhancement. That the erratic transitions between quiet sleep, active sleep without REM, and crying sleep were reduced means that the remaining transitions are stable and indicative of a meaningful pattern of infant behavior. This same argument applies to the alteration of the transition pattern between alert activity and crying.

Where there were significant interaction effects, the direction of the effect was to enhance the distinction already present in the raw data. In the state of active sleep without REM, the raw data showed that preterms spent a larger amount of time in this state than the other three groups of infants. After the program analysis, this distinction was further highlighted in that while there was a reduction in total number of observations for all groups, this reduction was significantly less for the group 1 preterms than for the other infants.

A similar effect occurred for the state of crying. In the raw data the FT/ SM and the FT/ C infants cried significantly more than the PT or the FT/ ICU infants. The data analysis sharpened this difference as the number of observations increased for the FT/ SM and FT/ C infants, decreased for the PTs, and only slightly increased for the FT/ ICUs.

In line with these results it is interesting to observe that in the literature reviewed for this study, several studies dealt with the differences in state behavior between preterm and full-term infants (cf. Parmelee et al. 1967; Holmes et al. Note 1), pointing out qualitative and quantitative distinctions. These observations are supported by the results of the present study and are consistent with the program analysis of the data.

The only result where an enhancement effect was not obtained and where a significant interaction occurred was in the state of fussing. In this case the increases in the number of observations for the

first two groups (PT; FT/ ICU) balance out the decreases for the third and fourth groups (FT/ SM; FT/ C). This created the situation where there were no significant effects from the program analysis across groups but a statistically significant interaction was obtained. The change in the scores for the FT/ ICU and FT/ SM groups were minimal and did not contribute much to the results. The preterm infants, however, had a large net increase in proportion of observations of fussing behavior while the FT/ C infants had a corresponding proportional decrease. In fact, the two groups virtually changed places with respect to their manifestation of fussing behavior. These results suggest that although the FT/ C infants (group 4) had more recorded observations of fussing behavior than the preterms (group 1), their behavior was less stable and more transitory than the fussing behavior of the preterms. While there was an initial difference quantitatively in the amount of fussing behavior between the two groups, an analysis of the data by the smoothing program showed that there was a qualifying qualitative difference not evident in the raw data. In this case the qualitative difference consisted of more erratic behavior on the part of the FT/ Cs. The program, in a sense, quantified this quality and reduced the total number of observations.

This finding would not have been possible without the program analysis and it might have been concluded that full terms show more fussing behavior than preterms, without noting that this behavior is brief and transitory. This results points towards the third function of the program, the creation of a new variable of infant state behavior.

Epoch Length

The program, of course, does not literally create the variable of epoch length. A list of "consecutive observations in state" could have just as easily been included in the printout for the raw data (cf. Figure 1). In all probability this list would not have had much use as the bulk of the state epochs would have been brief. Many epochs would have consisted of only a few observations. In the smoothed data, however, there is a larger range of epoch lengths present with a different distribution of scores that make this data more meaningful. To see why this is so, it is helpful to reconsider Figure 2 where a comparison of a raw and a smoothed data stream was presented.

In the first two rows of the raw data, there is a predominance of state 1 observations interspersed with a few observations of state 2 and state 3 behavior. Once the program analyzed this data, an extended epoch in state 1 was revealed. By the absorption of out-of-state characters, the program creates epochs that more accurately represent the pattern of an infant's behavior. The effect of converting epoch length into a meaningful variable then, is to make a pattern analysis of infant behavior possible. For example, while two groups of infants may spend the same amount of time in a state overall, the patterns of their state behavior may be vastly different. One group of infants may show several extended epochs in a given state while another group might exhibit more numerous but shorter state epochs (as in the case of the fussing behavior of the FT/ C and the PTs just discussed). The program

can be seen in this light as an additional diagnostic aid for the researcher interested in studying infant states.

In sum, it is hoped that the present study has resulted in the creation of a new research tool. An analysis of infant states that relies on behavioral criteria alone is hampered by the fact that infant behavior (especially in preterms) is poorly organized (Berg & Berg, 1979). Further, Parmelee et al. (1967) have shown that this instability of overt behavior leads to assessments of state manifestation that vary with respect to analyses using psychophysiological measures which tap variables with greater stability. Seen in this light, the program's main purpose is to mitigate the instability of infant behavior by ascertaining underlying patterns of behavior. Stated in another way, the program removes "noise" (spurious transitions) from the data without sacrificing information.

Future research might concentrate on evaluating infants with an eye towards elaborating subtle differences in state behavior that were previously obscured in hopes of discovering subtle but important determinants of infant development and behavior. To a lesser extent, the program might also be used for the evaluation of alternate state taxonomies to help determine which categories of infant behavior are stable and meaningful. Finally, the variable of epoch length made possible by the utilization of the program suggests another direction for measuring state behavior in infants.

REFERENCE NOTES

1. Holmes, D., Nagy, J., Slaymaker, F. L., McNeal, S., Gardner, T., & Pasternak, J. Sleeping, crying, and alertness in preterm and full-term infants. Paper presented at Southwestern Society for Research in Human Development, Lawrence, Kansas, 1980.
2. Holmes, D., Nagy, J., Pasternak, J., Slaymaker, F., Hall, L. The effect of observation period length on newborn state data. Unpublished manuscript, Loyola University, 1981.

REFERENCES

- Ashton, R. The state variable in neonatal research. Merrill-Palmer Quarterly, 1973, 19, 3-20.
- Berg, W., & Berg, K. Psychophysiological development in infant: State, sensory function, and attention. In J. Osofsky (Ed.), Handbook of infant development. New York: Wiley, 1979.
- Brown, J. L. States in newborn infants. Merrill-Palmer Quarterly, 1964, 10, 313-327.
- Dunn, J. Distress and comfort. Cambridge, Mass.: Harvard University Press, 1977.
- Escalona, S. K. The study of individual differences and the problem of state. Journal of Child Psychiatry, 1962, 1, 11-37.
- Korner, A. F. Neonatal startles, smiles, erections, and reflex sucks as related to state, sex, and individuality. Child Development, 1969, 40, 1039-1053.
- Korner, A. F. Visual alertness in neonates: Individual differences and their correlates. Perceptual and Motor Skills, 1970, 31, 499-509.
- Korner, A. F. State as variable, as obstacle, and as mediator of stimulation in infant research. Merrill-Palmer Quarterly, 1972, 18, 77-94.
- Korner, A. F., & Grobstein, R. Visual alertness as related to soothing in neonates: Implications for maternal stimulation and early deprivation. Child Development, 1966, 37, 867-876.
- Korner, A. F., & Thoman, E. B. Visual alertness in neonates as evoked by maternal care. Journal of Experimental Child Psychology, 1970, 10, 67-78.
- Lewis, M. State as an infant environment interaction. An analysis of mother-infant interactions as a function of sex. Merrill-Palmer Quarterly, 1972, 18, 95-122.
- Moss, H. A. Sex, age and state as determinants of mother-infant interaction. Merrill-Palmer Quarterly, 1967, 13, 19-36.
- Osofsky, J. D., & Danziger, B. Relationships between neonatal characteristics and mother-infant interaction. Developmental Psychology, 1974, 10(1), 124-130.

- Parmelee, A. H., Schulz, H. R., & Disbrow, M. A. Sleep patterns of the newborn. Journal of Pediatrics, 1961, 58, 241-250.
- Parmelee, A. H., Wenner, W. H., Akiyama, Y., Schultz, M., & Stern, E. Sleep states in premature infants. Developmental Medicine and Child Neurology, 1967, 9, 70-77.
- Precht1, H. F. R., Theorell, K., & Blair, A. W. Behavioral state cycles in abnormal infants. Developmental Medicine and Child Neurology, 1973, 15, 606-615.
- Roffwarg, H. P., Muzio, J. N., & Dement, W. C. Ontogenetic development of the human sleep-dream cycle. Science, 1966, 152, 604-619.
- Theorell, K., Precht1, H. F. R., Blair, A. W., & Lind, J. Behavioural state cycles of normal newborn infants. Developmental Medicine and Child Neurology, 1973, 15, 597-612.
- Thoman, E. B. Early development of sleeping behaviors in infants. In N. R. Ellis (Ed.), Aberrant development in infancy. Princeton, N.J.: Erlbaum, 1975a.
- Thoman, E. B. Sleep and wake behaviors in neonates: Consistencies and consequences. Merrill-Palmer Quarterly, 1975, 21, 295-314.
- Spitz, R. A., Emde, R. N., & Metcalf, D. R. Further prototypes of ego formation: A working paper from a research project on early development. The Psychoanalytic Study of the Child, 1970, 25, 417-441.
- Wolff, P. H. Observations on newborn infants. Psychosomatic Medicine, 1959, 21, 110-118.

APPENDIX A

APPENDIX A

DECK LISTING OF THE PROGRAM

```

$WATFIV          3084.0013.SWARTZ,TIME=620,PAGES=110
  DIMENSION IH (11),IDBABY(20),ITIME(20),IDATA(1200),ICHANG(12,12),
  1IRUN(12,675),ITOTAL(12),IAGE(20),TOTAL(10),PERCEN(10),TOTRAN(10),
  2CHANGE(10,10),PERTRN(10,10)
  REAL SUM(12),SUM2(12),SIZE(12)
  INTEGER RUNNER(100),FRQRUN(100),GOSTP
  DATA SUM,SUM2,SIZE /36*0./
  DATA ICHANG/144*0/,IRUN/8100*0/,ITOTAL/12*0
  READ 400, (IH(IJ),IJ=1,11)
400 FORMAT(11A1)
  5 I=1
  M=70
  IK=1
  IA=1
  OUT=0
  GOTO 15
 10 I=I+70
  M=I+69
  IK=IK+1
  IF(OUT.EQ.1.)GOTO 25
 15 READ 16, IDBABY(IK),ITIME(IK),IAGE,(IK),IDATA(J),J=I,M)
 16 FORMAT (I2,2X,I1,1X,I2,2X,70A1)
  IF(IDBABY(IK).EQ.0)GOTO 200
 20 DO 50 IN=I,M
  IF(IN.EQ.1)GOTO 41
  IF(IDATA(IN).EQ.12)GOTO 50
 41 DO 42 IO=1,10
  IF(IDATA(IN).EQ.IH(IO))IDATA(IN)=IO
 42 CONTINUE
  IF(IN.EQ.M)GOTO 43
  IF(IDATA(IN).EQ.IH(11).AND.IDATA(IN+1).EQ.IH(11))GOTO 45
 43 IF(IDATA(IN).EQ.IH(11))IDATA(IN)=11
  GOTO 50
 45 IDATA(IN)=12
  IDATA(IN+1)=12
 50 CONTINUE
 25 IF(I.EQ.1)GOTO 30
  L=I-1
  IF(OUT.EQ.1)GOTO 40
  IF(IDBABY(IK).EQ.IDBABY(IK-1).AND.ITIME(IK).EQ.ITIME(IK-1).AND.
  1IAGE(IK).EQ.IAGE(IK-1)) GOTO 40
  GOTO 200

```

C
C ANALYSIS ROUTINE FOR SMOOTHED DATA
C

```

30 L=1
   ISAME=1
40 IX=M-1
   DO 70 IM=L, IX
   IF(IDATA(IM).EQ.99)GOTO 199
   IF(IDATA(IM+1).EQ.99)GOTO 199
   N=IDATA(IM)
   K=IDATA(IM+1)
   ITOTAL(N)=ITOTAL(N)+1
65 ICHANG(N,K)=ICHANG(N,K)+1
   IF(N.EQ.K)GOTO 60
199 IRUN(N, ISAME)=IRUN(N, ISAME)+1
   IF(ISAME.GT.IA) IA=ISAME
   ISAME=1
   IF(IDATA(IM+1).EQ.99)GOTO 200
   IF(IDATA(IM).EQ.99)GOTO 200
   GOTO 70
60 ISAME= ISAME+1
70 CONTINUE
   GOTO 10
200 PRINT 250, IDBABY(IK-1), ITIME(IK-1), IAGE(IK-1), (ITOTAL(IP), IP=1, 12)
250 FORMAT (1H1, 11HSUBJECT NO. I3, 5X, 11HTIME OF DAY, I2, 5X, 14HGEST. AGE
1(WK), I4//30X, 17HSTATE FREQUENCIES//5X, 5HSTATE, 3X, 1H0, 5X, 1H1, 5X,
21H2, 5X, 1H3, 5X, 1H4, 5X, 1H5, 5X, 1H6, 5X, 1H7, 5X, 1H8, 5X, 1H9, 4X, 13HINTER
3VENTIONS , 2X, 8HTIMEOUTS/11X, I3, 9(3X, I3), 10X, I3, 5X, I3)
   DIVIS=0
   DO 100 IZ=1, 10
   DIVIS=DIVIS+ITOTAL(IZ)
100 CONTINUE
   DO 150 IP=1, 10
   TOTAL(IP)=ITOTAL(IP)
   PERCEN(IP)=TOTAL(IP)/DIVIS*100.
150 CONTINUE
   PRINT 420, (PERCEN(IAZ), IAZ=1, 10)
420 FORMAT(//30X, 29HPERCENT OBSERVATIONS IN STATE//5X, 5HSTATE, 3X, 1H0,
17X, 1H1, 7X, 1H2, 7X, 1H3, 7X, 1H4, 7X, 1H5, 7X, 1H6, 7X, 1H7, 7X, 1H8, 7X, 1H9//9X
2, F5.2, 9(3X, F5.2))
600 PRINT 650, ((ICHANG(IB, IC), IB=1, 12), IC=1, 12)
650 FORMAT(//30X, 22HTRANSITION FREQUENCIES//10X, 5H02/01, 3X, 1H0, 6X, 1H1,
16X, 1H2, 6X, 1H3, 6X, 1H4, 6X, 1H5, 6X, 1H6, 6X, 1H7, 6X, 1H8, 6X, 1H9, 3X, 13HINTE
2RVENTIONS, 3X, 8HTIMEOUTS/11X, 1H0, 10(4X, I3), 10X, I3, 6X, I3/11X, 1H1, 10(
34X, I3), 10X, I3, 6X, I3/11X, 1H2, 10(4X, I3), 10X, I3, 6X, I3/11X, 1H3, 10(4X, I
43), 10X, I3, 6X, I3/11X, 1H4, 10(4X, I3), 10X, I3, 6X, I3/11X, 1H5, 10(4X, I3), 1
50X, I3, 6X, I3/11X, 1H6, 10(4X, I3), 10X, I3, 6X, I3/11X, 1H7, 10(4X, I3), 10X, I
63, 6X, I3/11X, 1H8, 10(4X, I3), 10X, I3, 6X, I3/11X, 1H9, 10(4X, I3), 10X, I3, 6X
7, I3/1X, 13HINTERVENTIONS, 2X, I3, 9(4X, I3), 10X, I3, 6X, I3/5X, 9HTIME OUTS
8, 2X, I3, 9(4X, I3), 10X, I3, 6X, I3)
   DO 170 IAE=1, 10
   TOTRAN(IAE)=0
170 CONTINUE
   DO 180 IAF=1, 10
   DO 180 IAG=1, 10

```

```

TOTRAN(IAF)=TOTRAN(IAF)+ICHANG(IAF, IAG)
180 CONTINUE
DO 190 IAA=1,10
DO 190 IAB=1,10
CHANGE(IAA, IAB)=ICHANG(IAA, IAB)
IF(TOTRAN(IAA).EQ.0)GOTO 185
GOTO 187
185 PERTRN(IAA, IAB)=99.99
GOTO 190
187 PERTRN(IAA, IAB)=ICHANG(IAA, IAB)/TOTRAN(IAA)*100.
190 CONTINUE
PRINT 450, ((PERTRN(IAC, IAD), IAC=1, 10), IAD=1, 10)
450 FORMAT(/ /30X, 24HTRANSITION PROBABILITIES//10X, 5H02/01, 3X, 1H0, 9X, 1
1H1, 9X, 1H2, 9X, 1H3, 9X, 1H4, 9X, 1H5, 9X, 1H6, 9X, 1H7, 9X, 1H8, 9X, 1H9/11X, 1H0
2, 10(4X, F6.2)/11X, 1H1, 10(4X, F6.2)/11X, 1H2, 10(4X, F6.2)/11X, 1H3, 10(4X
3, F6.2)/11X, 1H4, 10(4X, F6.2)/11X, 1H5, 10(4X, F6.2)/11X, 1H6, 10(4X, F6.2)
4/11X, 1H7, 10(4X, F6.2)/11X, 1H8, 10(4X, F6.2)/11X, 1H9, 10(4X, F6.2))
IF(OUT.NE.1)GOTO 719
PRINT 500
500 FORMAT(/ /30X, 33HCONSECUTIVE OBSERVATIONS IN STATE//5X, 5HSTATE, 4X, 1
1H0, 5X, 1H1, 5X, 1H2, 5X, 1H3, 5X, 1H4, 5X, 1H5, 5X, 1H6, 5X, 1H7, 5X, 1H8, 5X, 1H9/
2)
ASTER=0
DO 900 IS=1, IA
DO 835 ILK=1, 10
835 IF(IRUN(ILK, IS).NE.0)GOTO 840
IF(ASTER.NE.0)GOTO 900
PRINT 920
920 FORMAT('*****')
ASTER=1.
GOTO 900
840 PRINT 850, IS, ((IRUN(IQ, IR), IQ=1, 10), IR=IS, IS)
DO 843 ILK=1, 10
SUM(ILK)=SUM(ILK)+IS*IRUN(ILK, IS)
SUM2(ILK)=SUM2(ILK)+IS**2*IRUN(ILK, IS)
843 SIZE(ILK)=SIZE(ILK)+IRUN(ILK, IS)
ASTER=0
850 FORMAT(6X, I3, 10(3X, I3)/)
900 CONTINUE
DO 842 ILK=1, 10
IF(SIZE(ILK).EQ.0)GOTO 842
SUM(ILK)=SUM(ILK)/SIZE(ILK)
SUM2(ILK)=SQRT((SUM2(ILK)/SIZE(ILK))-SUM(ILK)**2)
842 CONTINUE
PRINT 847, (SUM(JIJ), JIJ=1, 10)
847 FORMAT(' MEAN ', 10(F5.2, 1X))
PRINT 848, (SUM2(JIJ), JIJ=1, 10)
848 FORMAT(' STD DEV ', 10(F5.1, 1X))
PRINT 849, (SIZE(JIJ), JIJ=1, 10)
849 FORMAT(' SAMPLE N ', 10(F5.2, 1X))
DO 463 INR=1, 100
463 RUNNER(INR)=FRQRUN(INR)=0
GOSTP=NPTR=1

```

```

465 KICK=1
467 IF(IDATA(NPTR).NE.IDATA(NPTR+1))GOTO 469
    NPTR=NPTR+1
    KICK=KICK+1
    GOTO 467
469 RUNNER(GOSTP)=IDATA(NPTR)-1
    FRQRUN(GOSTP)=KICK
    GOSTP=GOSTP+1
    NPTR=NPTR+1
    IF(IDATA(NPTR).NE.99)GOTO 465
    PRINT 473
473 FORMAT(' '/SMOOTHED DATA STREAM'/)
    PRINT 471,(FRQRUN(KICK),RUNNER(KICK),KICK=1,GOSTP)
471 FORMAT(' ',10(I4,'*'I2,'---'))
    OUT=0
    GOTO 377

C
C   BEGINNING OF THE SMOOTHING ROUTINE
C   STATEMENT 433 SETS THE FINAL ELEMENT OF THE RAW DATA VECTOR
C
719 OUT=1
433 IDATA(I-1)=99
    J=0

C
C   ENTRY UPON STATE INTERRUPT: STATE INTERRUPT OCCURS WHEN THERE IS
C   EITHER A BREAK IN STATE BECAUSE OF FOUR CONSECUTIVE OUT OF STATE
C   CHARACTERS OR BECAUSE OF AN INTERRUPT OR TIMEOUT IN THE DATA
C   VECTOR
C   STATE INTERRUPT IS BRANCHED TO FROM STATE CONTINUATION, FROM THE
C   2/3 STATE SEGMENT, AND FROM TRANSITION PROBABILITIES
C   STATE INTERRUPT BRANCHES TO THE 2/3 STATE SEGMENT AND THE
C   ANTICIPATION SEGMENT
C
117 K=J+1

C
C   STATEMENTS 78 TO 357 CHECK FOR AN INTERRUPT OR DATA END
C
78 IF(IDATA(K).EQ.11.OR.IDATA(K).EQ.12)GOTO 64
    IF(IDATA(K).EQ.99)GOTO 364
    IF(IDATA(K+1).EQ.11.OR.IDATA(K+1).EQ.12)GOTO 39
    IF(IDATA(K+1).EQ.99)GOTO 91
    IF(IDATA(K+2).EQ.11.OR.IDATA(K+2).EQ.12)GOTO 26
    IF(IDATA(K+2).EQ.99)GOTO 26
357 IF(IDATA(K).EQ.IDATA(K+1).AND.IDATA(K).EQ.IDATA(K+2))GOTO 130

C
C   IF STATEMENT 357 IS TRUE, A STATE HAS BEEN FOUND
C   A STATE IS DEFINED AS THREE CONSECUTIVE OBSERVATIONS THAT ARE
C   THE SAME
C
    IF(K.GT.1)GOTO 52

```

```

    IDATA(K)=12
    GOTO 64
26 IF(K.LE.(J+2))GOTO 28
    K=K+2
    GOTO 99
28 IDATA(K+1)=12
    IF(K.GT.(J+1))IDATA(K-1)=12
39 IDATA(K)=12
64 J=J+1
52 K=K+1
    GOTO 78
91 IDATA(K)=12
    GOTO 364
C
C ENTRY TO THE ANTICIPATION SEGMENT OF THE ROUTINE
C ANTICIPATION IS DEFINED AS A RUN OF ONE TO THREE TRIALS IN NEXT
C STATE FOLLOWED BY ONE TO THREE TRIALS RESPECTIVELY OF OUT OF STATE
C TRIALS BEFORE THE STATE IS ENTERED
C THE ANTICIPATION SEGMENT IS BRANCHED TO FROM THE STATE INTERRUPT
C SEGMENT AND FROM THE 2/3 STATE SEGMENT WHEN THERE IS A TRANSITION
C FIELD (SERIES OF OUT OF STATE CHARACTERS BETWEEN STATES) OF AT
C LEAST THREE CHARACTERS
C THE ANTICIPATION SEGMENT BRANCHES TO THE 2/3 STATE SEGMENT, THE
C TRANSITION PROBABILITIES SEGMENT, AND TO STATE CONTINUATION
C
130 IF(K.LE.(J+1)) GOTO 143
    IF(IDATA(K-1).NE.IDATA(K))GOTO 987
    K=K-1
    GOTO 130
987 IF(K-1).LE.(J+1)) GOTO 158
    IF(IDATA(K-2).EQ.IDATA(K))GOTO 169
    IF((K-3).GT.(J+1)) GOTO 195
    IF(IDATA(J).LE.10)GOTO 213
    IDATA(K-3)=12
    IDATA(K-2)=12
156 IDATA(K-1)=12
    GOTO 143
158 IF(IDATA(J).GT.10)GOTO 156
C
C IF STATEMENT 158 IS FALSE (I.E.IDATA(J) IS A STATE OBSERVATION)
C THE PROGRAM GOES TO THE TRANSPROB SEGMENT
C
    GOTO 213
195 IF(IDATA(K-4).EQ.IDATA(K-3).AND.IDATA(K-3).EQ.IDATA(K))GOTO 208
    GOTO 99
208 IDATA(K-2)=IDATA(K-1)=IDATA(K)
C
C STATEMENT 208 SMOOTHS ACCORDING TO ANTICIPATION
C
    K=K-2
    GOTO 182
169 IDATA(K-1)=IDATA(K)

```



```

C
C     STATEMENT 169 SMOOTHS ACCORDING TO ANTICIPATION
C
182 K=K-2
    GOTO 130
C
C     ENTRY TO THE STATE CONTINUATION SEGMENT OF THE ROUTINE
C     THE DATA VECTOR IS BEING CHECKED FOR CONTINUATION IN STATE AND
C     PERSEVERATION
C     PERSEVERATION IS DEFINED AS A DROP OUT OF STATE FOR ONE TO THREE
C     TRIALS FOLLOWED BY A RETURN TO STATE FOR THE SAME NUMBER OF TRIALS
C     STATE CONTINUATION IS BRANCHED TO FROM THE ANTICIPATION SEGMENT
C     AND BRANCHES TO THE STATE INTERRUPT SEGMENT
C
143 J=K+2
221 IF(IDATA(J+1).EQ.11.OR.IDATA(J+1).EQ.12)GOTO 117
    IF(IDATA(J+1).EQ.99)GOTO 364
    IF(IDATA(J+1).EQ.IDATA(J))GOTO 247
    IF(IDATA(J+2).EQ.11.OR.IDATA(J+2).EQ.12)GOTO 260
    IF(IDATA(J+2).EQ.99)GOTO 273
    IF(IDATA(J+2).EQ.IDATA(J))GOTO 286
    IF(IDATA(J+3).EQ.11.OR.IDATA(J+3).EQ.12)GOTO 299
    IF(IDATA(J+3).EQ.99)GOTO 312
82 IF(IDATA(J+3).EQ.IDATA(J+2).AND.IDATA(J+3).EQ.IDATA(J+1))GOTO 325
C
C     WHEN STATEMNET 82 IS TRUE A NEW STATE IMMEDIATELY FOLLOWS AN OLD
C     STATE
C
    IF(IDATA(J+4).EQ.IDATA(J+3).AND.IDATA(J).EQ.IDATA(J+4))GOTO 338
    IF(IDATA(J+4).EQ.IDATA(J+5).AND.IDATA(J+4).EQ.IDATA(J+6).AND.
1 IDATA(J+6).EQ.IDATA(J))GOTO 351
    GOTO 117
351 IDATA(J+1)=IDATA(J)
    J=J+1
338 IDATA(J+1)=IDATA(J)
    J=J+1
286 IDATA(J+1)=IDATA(J)
    J=J+1
C
C     STATEMENTS 351,338,286 SMOOTH ACCORDING TO PERSEVERATION
C
247 J=J+1
    GOTO 221
325 K=J+1
    GOTO 143
299 IDATA(J+1)=12
    J=J+1
260 IDATA(J+1)=12
    J=J+2
    GOTO 117
273 IDATA(J+1)=12
    GOTO 364
312 IDATA(J+1)=12

```

```

      IDATA(J+2)=12
364 CONTINUE
C
C   STATEMENTS 377 TO 370 INITIALIZE MATRICES FOR COMPUTATION OF
C   SUMMARY CHARACTERISTICS FOR THE SMOOTHED DATA VECTOR
C
377 I=1
      M=I+69
      IF(OUT.EQ.1.)JAS=IK
      IK=1
      IA=1
      DO 350 IT=1,12
      ITOTAL(IT)=0
      SUM(IT)=0
      SUM2(IT)=0
      SIZE(IT)=0
350 CONTINUE
      DO 360 IU=1,12
      DO 360 IV=1,12
      ICHANG(IU,IV)=0
360 CONTINUE
      DO 370 IW=1,12
      DO 370 IX=1,240
      IRUN (IW,IX)=0
370 CONTINUE
      IF(OUT.EQ.1)GOTO 30
C
C   IF OUT=1 PROGRAM BRANCHES TO ANALYSIS ROUTINE FOR SMOOTHED DATA
C
      ITIME(1)=ITIME(JAS)
      IDBABY(1)=IDBABY(JAS)
      IAGE(1)=IAGE(JAS)
      DO 300 ID=1,70
300 IDATA(ID)=IDATA(IN+ID-71)
      GOTO 30
C
C   ENTRY TO THE 2/3 STATE SEGMENT OF THE ROUTINE
C   2/3 STATE IS DEFINED AS TWO CONSECUTIVE CHARACTERS ALONG THE DATA
C   VECTOR THAT ARE THE SAME
C   THIS SEGMENT IS BRANCHED TO FROM THE ANTICIPATION SEGMENT AND
C   FROM THE STATE INTERRUPT SEGMENT
C   2/3 STATE BRANCHES TO THE ANTICIPATION SEGMENT, THE STATE INTER-
C   RUPT SEGMENT AND THE TRANSITION PROBABILITIES SEGMENT
C
99 N=K-1
      L=J
66 L=L+1
22 IF(L.EQ.N)GOTO 11
      IF(IDATA(L).EQ.IDATA(L+1))GOTO 33
      GOTO 66
33 IF((L.GT.(J+1).AND.IDATA(L-2).EQ.IDATA(L))GOTO 55
      IF(L+2).EQ.N)GOTO 11
      IF(IDATA(L+3).EQ.IDATA(L+1))GOTO 44

```

```

      IF((L+4).GE.N)GOTO 11
      IF(IDATA(L+4).EQ.IDATA(L).AND.IDATA(L+5).EQ.IDATA(L))GOTO 88
      GOTO 66
44  IDATA(L+2)=IDATA(L+1)
      K=L
      GOTO 130
55  IDATA(L-1)=IDATA(L)
C
C    STATEMENT 55 SMOOTHS ACCORDING TO ANTICIPATION
C
      K=L-2
      GOTO 130
11  IF(IDATA(K).GT.10.OR.IDATA(J).GT.10)GOTO 77
C
C    IF STATEMENT 11 IS TRUE, THE TRANSITION FIELD CANNOT BE SMOOTHED
C    BY THE TRANSITION PROBABILITY SEGMENT AS IT BEGINS OR ENDS IN
C    AN INTERRUPT OR A TIMEOUT
C
      GOTO 213
77  L=J+1
      DO 7 IVI=L,N
      7  IDATA(IVI)=12
      J=N
      IF(IDATA(K).EQ.99)GOTO 364
      GOTO 143
88  IDATA(L+2)=IDATA(L+3)=IDATA(L)
      K=L
      GOTO 130
113 J=J+1
C
C    ENTRY TO THE TRANSITION PROBABILITIES SEGMENT OF THE ROUTINE
C    THIS SEGMENT IS BRANCHED TO FROM THE ANTICIPATION SEGMENT OF THE
C    PROGRAM AND FROM THE 2/3 STATE SEGMENT
C    TRANSITION PROBABILITIES BRANCHES TO THE STATE CONTINUATION SEGMENT
C    THE LEAST PROBABLE TRANSITION GETS ABSORBED
C
213 IF(K.EQ.J+1)GOTO 143
      IF(PERTRN(IDATA(J),IDATA(J)).EQ.0)GOTO 313
      IF(PERTRN(IDATA(K-1),IDATA(K-1)).EQ.0)GOTO 219
      IF(((PERTRN(IDATA(J+1),IDATA(J))/PERTRN(IDATA(J),IDATA(J))).GT.
1(PERTRN(IDATA(K),IDATA(K-1))/PERTRN(IDATA(K-1),IDATA(K-1))))
2GOTO 313
219 IDATA(J+1)=IDATA(J)
      GOTO 113
313 IDATA(K-1)=IDATA(K)
      K=K-1
      GOTO 213
      END
$ENTRY
0123456789

```

APPENDIX B

APPENDIX B

FLOW CHART OF THE PROGRAM LOGIC

The flow chart beginning on page 87 is a diagram of the logic (series of decision procedures) used by the functioning program to redefine the infant state data. The direction of flow is from the top of the page to the bottom and from left to right, unless otherwise indicated by arrows. Table 4 identifies and provides definitions for the symbols used in the flow chart.

Table 4

Definitions of Flow Chart Symbols

Symbol	Definition
J,K,L,N	Letters not enclosed in parentheses are pointers used to indicate a given position on the data vector.
(J),(K), (L),(N), (J+1), etc.	Letters enclosed in parentheses stand for the actual character or digit in a given position on the data vector.
R,S,T,U, V,W,X,Y,Z	Used as off-page connectors meaning that a particular line of decision steps continues on another page, as indicated by the same letter on both pages.
OP	Used as an on-page connector meaning a particular line of decision steps continues on the same page.
exit	Marks the point at which the program leaves the smoothing routine as a blank has been encountered.
B	Blank or 99, indicates to the computer the end of a data vector.
11	Interrupt in the data collection, not to be analyzed with the data.
12	Time out by the researcher from data collection, not to be analyzed with the data.

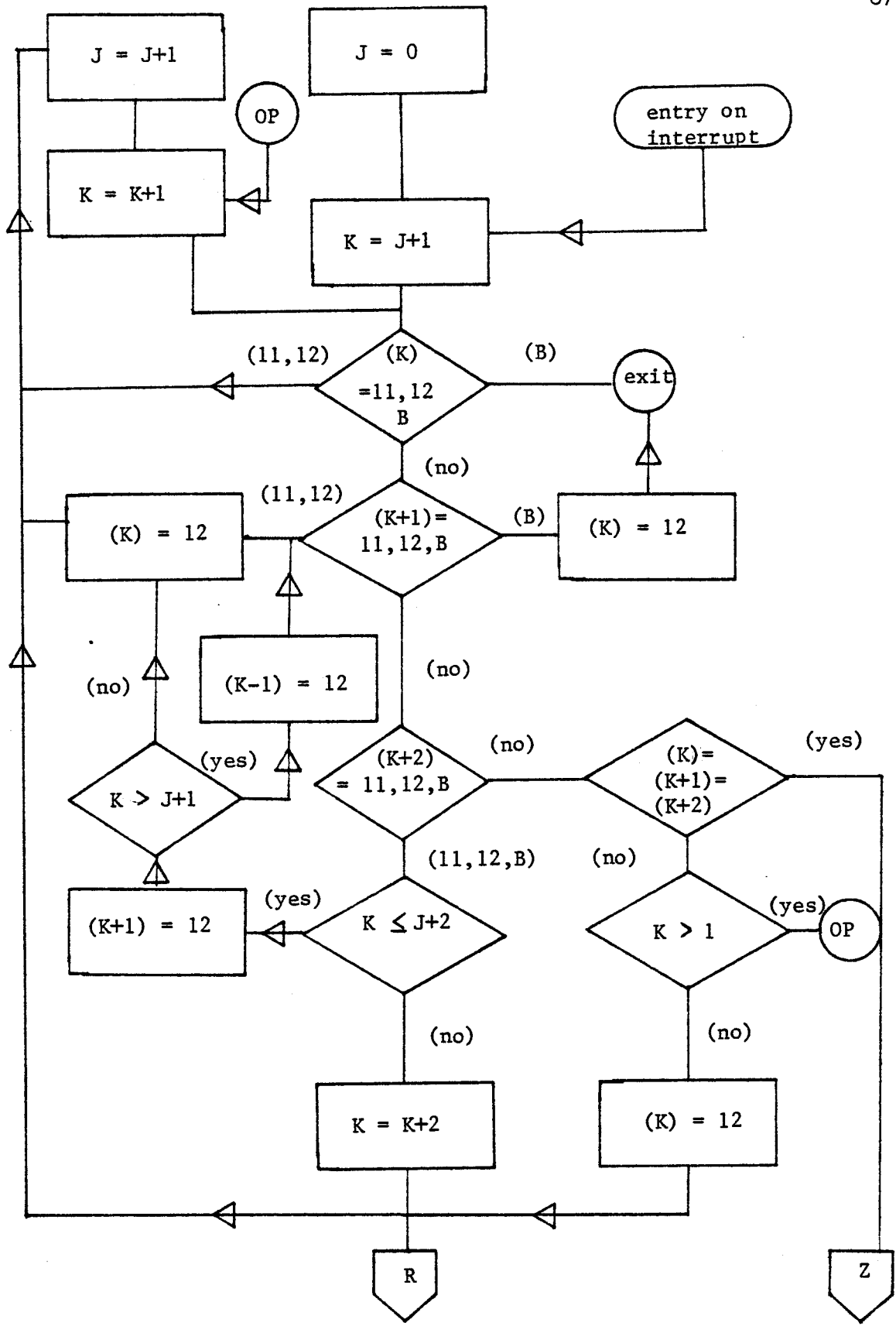

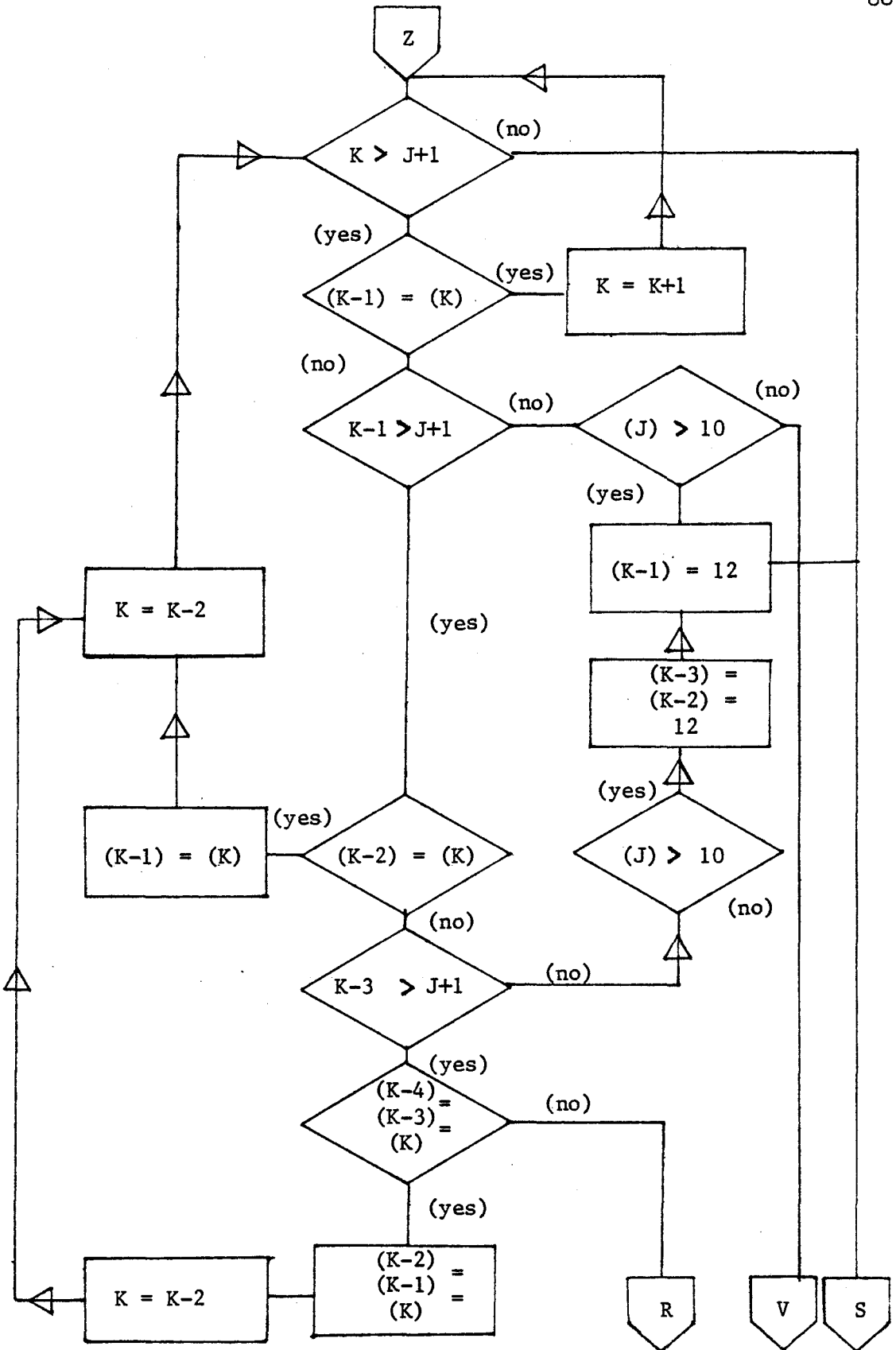

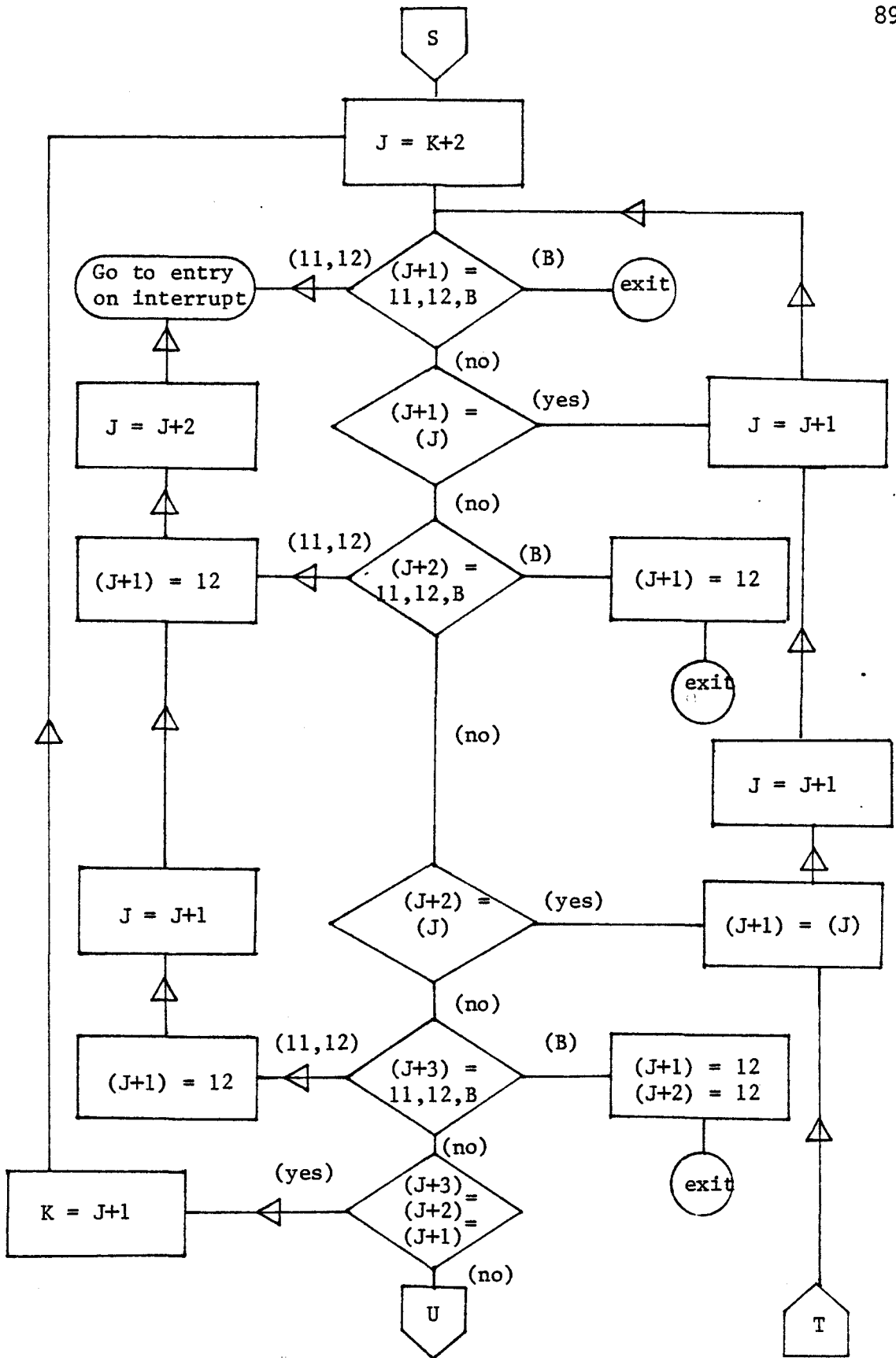

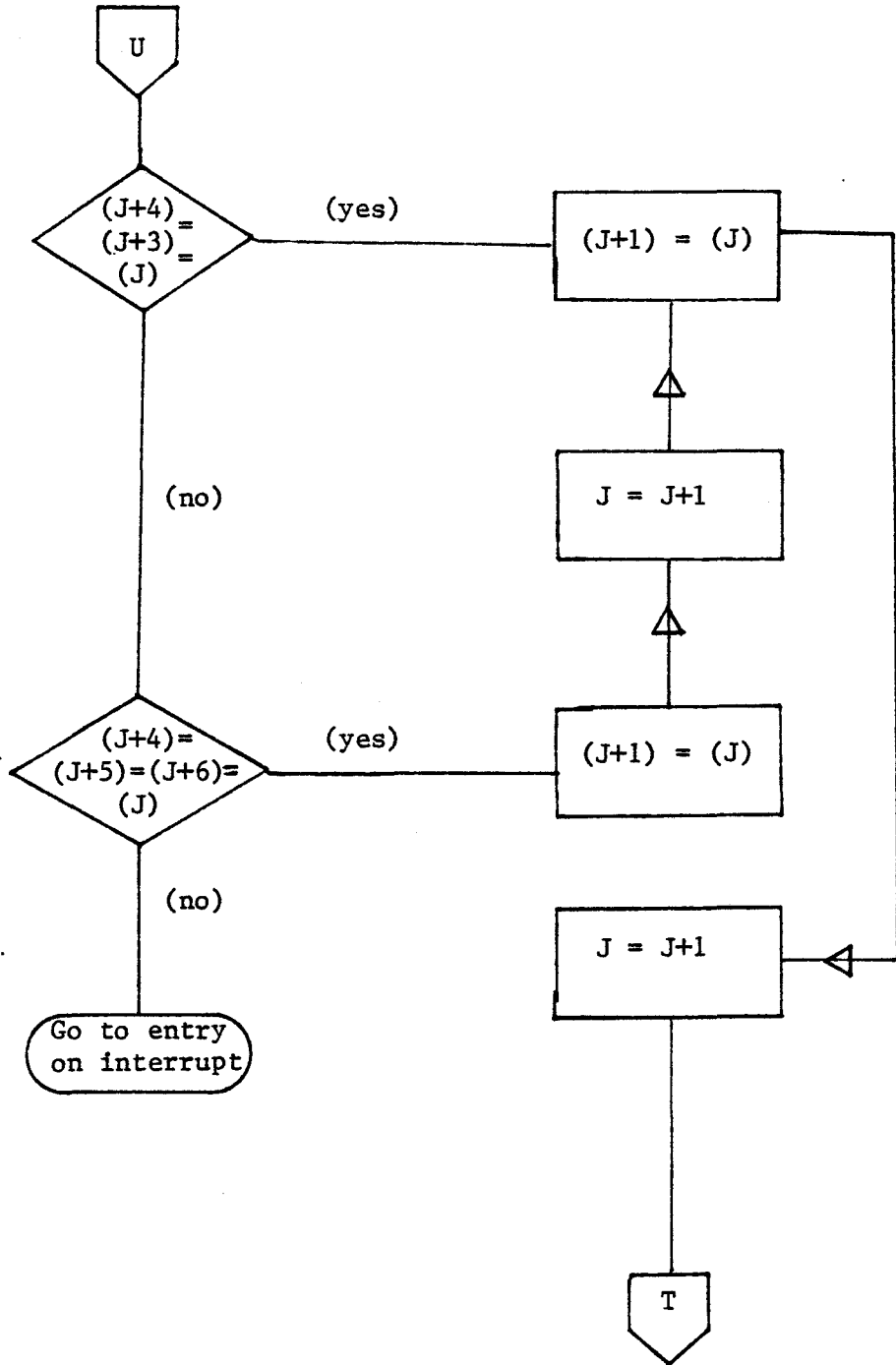

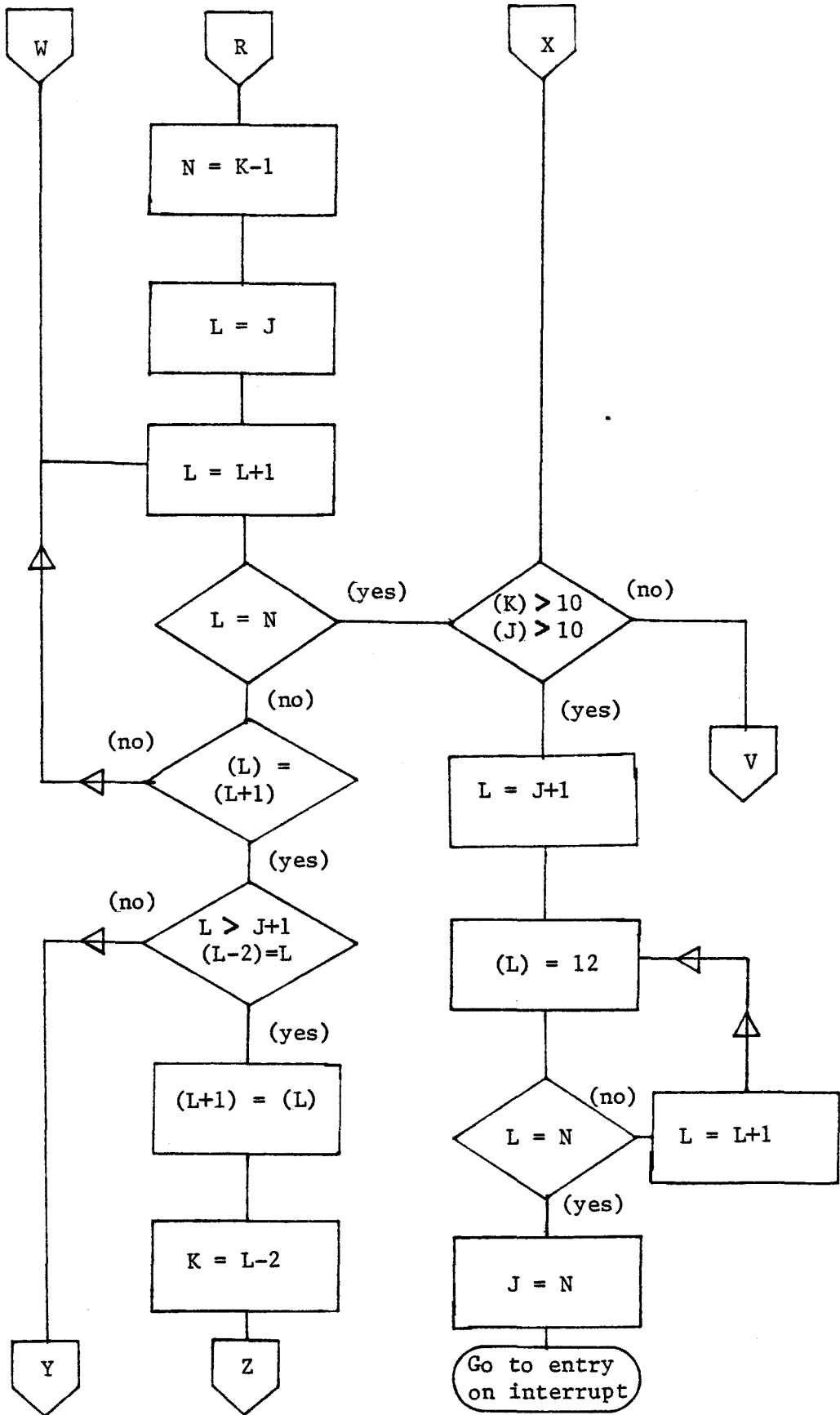

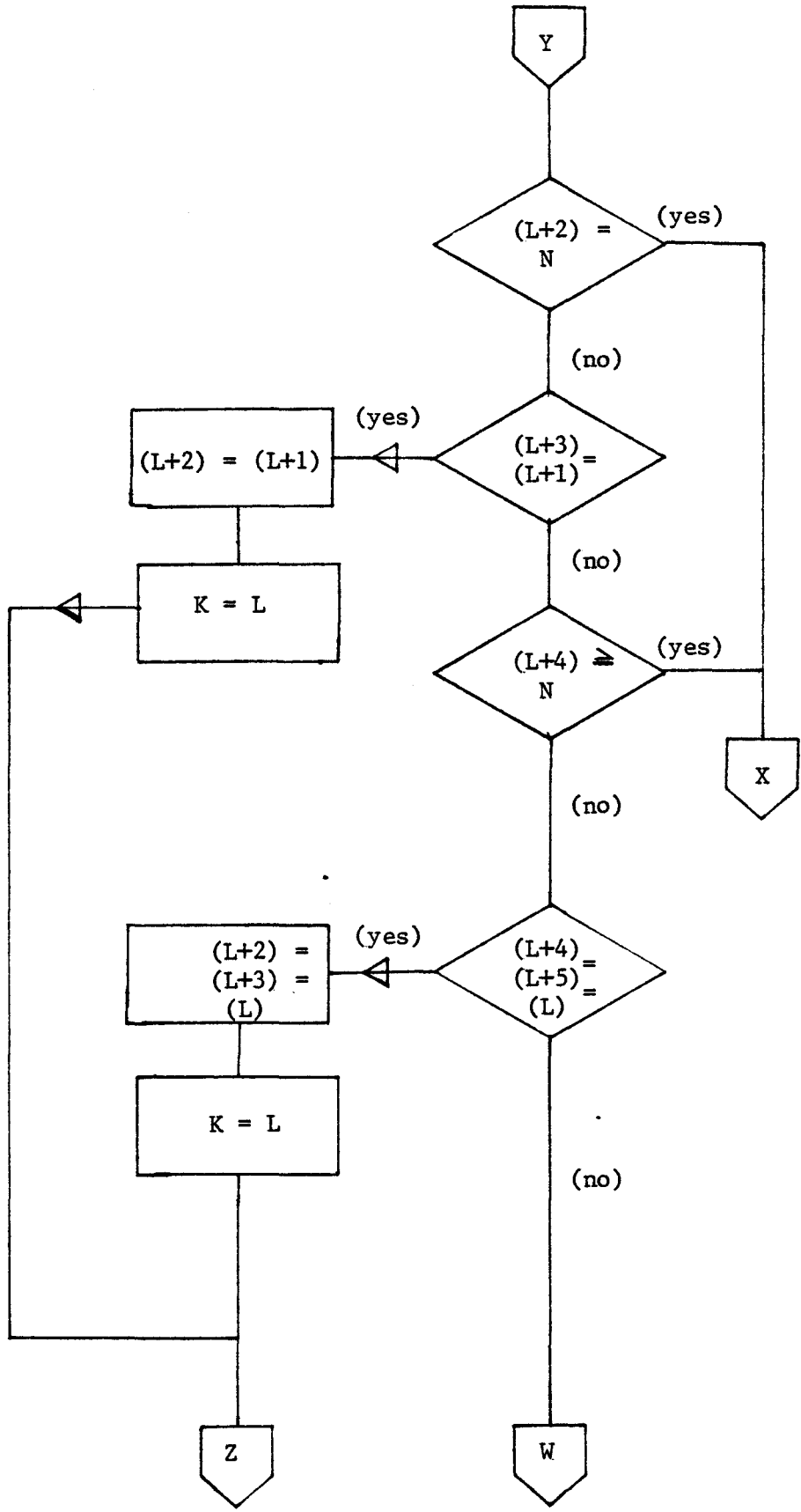

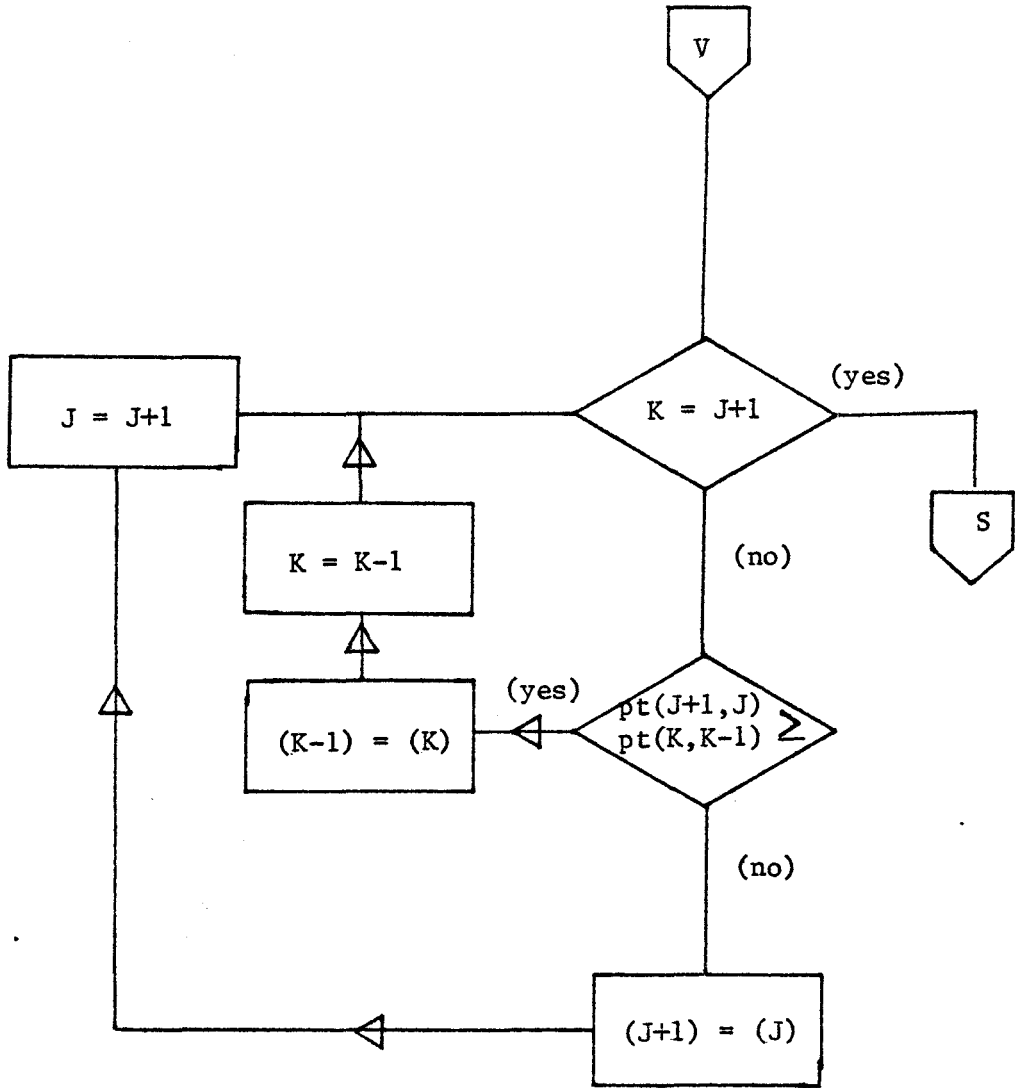

APPROVAL SHEET

The thesis submitted by James A. Swartz has been read and approved by the following committee:

Dr. Frank Slaymaker, Director
Assistant Professor, Psychology, Loyola

Dr. Jill Nagy
Assistant Professor, Psychology, Loyola

Dr. Deborah Holmes
Associate Professor, Psychology, Loyola

The final copies have been examined by the director of the thesis and the signature which appears below verifies the fact that any necessary changes have been incorporated and that the thesis is now given final approval by the committee with reference to content and form.

The thesis is therefore accepted in partial fulfillment of the requirements for the degree of Master of Arts.

November 4, 1981
Date

Frank Slaymaker
Director's Signature