

# Logistic Approach of Building and Development of Production Systems

## *Logistički pristup građenju i razvoju sustava proizvodnje*

Ján Kmec

Department of Mechanical Engineering  
Institute of Technology and Business  
České Budějovice, Czech Republic  
e-mail: kmec@mail.vstecb.cz

Štefan Valenčík

Department of Production Engineering  
Faculty of Mechanical Engineering  
Technical University of Košice, Slovak Republic  
e-mail: stefan.valencik@tuke.sk

Miroslav Gombár

The Department of Mechanical Engineering  
Institute of Technology and Business  
České Budějovice, Czech Republic  
e-mail: gombar@mail.vstecb.cz

Monika Karková

Department of Mechanical Engineering  
Institute of Technology and Business  
České Budějovice, Czech Republic  
e-mail: karkova@mail.vstecb.cz

Alena Vagaská

Department of Mathematics, Informatics and Cybernetics  
Faculty of Manufacturing Technologies Technical  
University of Košice with a seat in Presov, Slovak Republic  
e-mail: alena.vagaska@tuke.sk

DOI 10.17818/NM/2016/SI13

UDK 338.45.01

Preliminary communication / *Prethodno priopćenje*  
Paper accepted / *Rukopis primljen*: 21. 3. 2016.

### Summary

The paper presents a complex of information aimed at automated production systems structures and simulation. For production systems intergrated structures formation it uses logistic principles for making the internal material flow among various logistic nodes more precise and effective, including respective information flow, here e. g. with use of integrable and compatible handling and technological systems, as well.

### KEY WORDS

modular and multifunctional  
production system  
structure formation  
production logistic chain

### Sažetak

*Članak prezentira kompleksnu informaciju koja ima za cilj strukture automatiziranih proizvodnih sustava i simulaciju. Za integrirano oblikovanje proizvodnih sustava koristi logističke principe da bi učinila interni tijek među različitim logističkim čvorovima preciznijim i djelotvornijim uključujući pripadajući protok t.j. korištenje i integrabilnog i kompatibilnog rukovanja tehnoloških sustava*

### KLJUČNE RIJEČI

modularni i višefunkcionalni sustav  
proizvodnje  
formiranje struktura  
lanac logističke proizvodnje

## 1. INTRODUCTION

Recent trends aimed at development and using basic resources lead to looking for new and higher effects solutions. These are mostly connected with an effort to fully and intensively solve functions in the framework of machine ensemble, assembly and system, i.e. with extending mutually interconnected links leading to growth and transformation of construction moduls and machine systems integrated assemblies function. The creation of satisfying solutions is in accordance to industrial practice requirements to innovate strategic change and restructuralization of company systems with respect to market adaptability, manufacturing efficiency, competitiveness and provided services level growth.

## 2. STARTING POINTS OF PRODUCTION SYSTEM CONSTRUCTION AND DEVELOPMENT

Machine-controlled manufacturing systems have undergone considerably development and have been installed at many production places effectively running in various configurations and within a wide spectrum. However, after their evolutionary development, a sufficient and exact description of installed and designed systems defining realtions and boundaries inside systems and among them is missing so that their further development could be defined [1].

Problems with building of machine-controlled manufacturing systems have to answer several questions,

especially a question of technical and working base and its integration, company preparation manufacturing level, competitive manufacturing position, development forecast, company culture, but neither they always answer to aptness of appropriate structure. In future, structures with a certain degree of flexibility, ranking, investment utilizability and reconfigurability. A manufacturing systems new types structures development thus requires answers to other questions supporting integrity, equivalency and synergy of functions and activity. They become determining factors for simple and unambiguous integrating into production-logistic chain Fig 1 [4,5], i.e. ability to create appropriate logistic infrastructure of information and material flow and thus make process-value chains more real also for purposes considerably different from an original intention [4,5].

## 3. SOLUTION LOGISTIC PRINCIPLES IMPORTANCE

To reach market production and all company adaptability and efficiency is not able without logistic principles applying and logistic solutions creating. Thus, particular production activities and its supporting components are more and more bound and dependent.

The importance of logistic is in integration of so far self-governing production functions (and often also production divisions) of technology, handling, transport and storage into

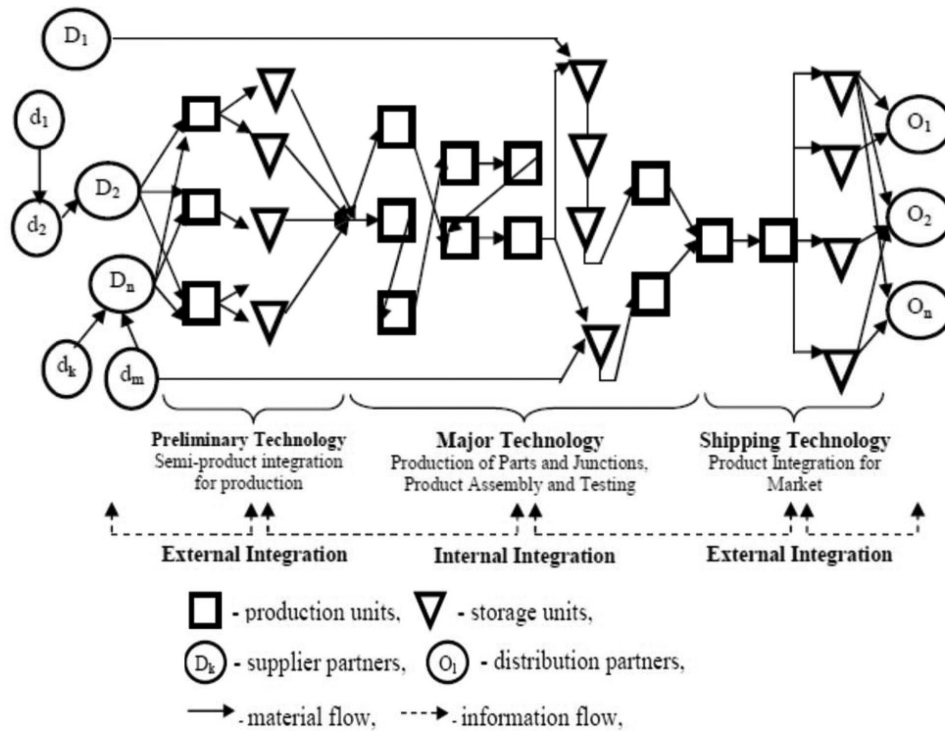

Figure 1 Production and logistic network

one orderly oriented system (internal integration) and then after linking the production company with its suppliers and distributions partners up to final customer into the integrated logistic chain (external integration) according to integrated material flow (Fig 1). Using of logistic, integration and integrated solutions for creating of production systems structures wants to specify and increase efficiency of internal material flow among various logistic junctions, including appropriate information flow in manufacturing centres [4]. Structure logistic production systems vitality and outlook have to be understood within wider interconnection of manufacturing functions by way of integrable and compatible handling and technology systems.

This trend conditions applying of progressive conceptions of manufacturing, transporting and storage systems. The way to these targets is introducing of logistic structures of machine-controlled production systems respecting variety of production objects and basic technology methods, mechanization and flexibility level as well as other indicators.

#### 4. PRODUCTION SYSTEM PROFILING PRINCIPLES

From sources for machine-controlled technology processing, handling, controlling and from their linking elements, the controlled production systems are assembled. The least structural units, which are a base for particular production systems, are elements and units (construction modules). These elements and units are linked by material and information links and can be grouped into more complex units (manufacturing section, department, plant). According to grouping of physical elements and units, their spatial arrangement and ways of material and information linking, the productions systems can be developed onto new and higher integrated level, i.e.:

- into fully valuable technology or manufacturing module and its extending (a production system basic model),
- into complex production system of a higher level (a complex production level).

A determining fact is that decisive activities of material and often of information flow are implemented through integrating devices of operational handling (handler, industrial robot) and transport (pushcart and conveyor systems) and they are differentiated according to a hierarchical level.

In case of the basic model of production system (VS) these things can be expressed as follows:

$$VS = \left[ IM \xleftrightarrow{i,m} [\{T_a\}_{a=1,\dots,o}, \{MU_e\}_{e=1,\dots,p}] \right] \quad (1)$$

where:

- IM – integrating handling device (handel, industrial robot),
- $T_a$  – technological device (NC machine, CNC machine),
- $MU_e$  – handling junction (receiving and delivering device for objects, pallets),
- a – number of technology device,
- e – number of handling junction,
- $\xleftrightarrow{i,m}$  – information and material communication.

#### Basic model

In (Fig 2) standard forms of the production system basic models have been defined [5]. They are formed by level of integrity of information and material links in the process of time, as e. g. technological modul  $TM$ , production modul (VM), production cell (VB).

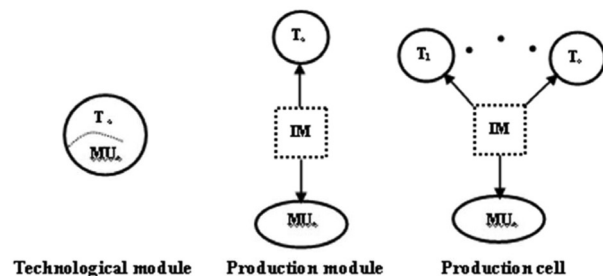

Figure 2 Forms of production system basic model

### Complex model

To describe wider ties of information and material flow it is able only at solution of complex production systems integrated and grouped by means of linking of production systems and storage systems basic models by a central system of interoperational transport and central control system. The structure of the complex production system (KVS) can be expressed as:

$$KVS = \left[ ID \xleftrightarrow{i,m} \left[ \{VS_k\}_{k=1,\dots,t}, \{SU_l\}_{l=1,\dots,s} \right] \right] \quad (2)$$

where:

- ID – integrating transport system (cart, conveyor),
- $VS_k$  – production system basic model (technological modul, production modul, production cell),
- $SU_l$  – storage junction (interoperational, central enter-exit storehouse),
- $k$  – production system number,
- $l$  – storage junction number.

Complex production systems (Fig 3) extend integration among production system basic models (technological and production module, production cell) so that they group them around transport system which links tangible moduls and cells with storage junction. The transport system carries out material flow in dependence of situation between the storage junction and technological and production modules, production cells or between technological and production modules and production cells mutually. Poly-bond combined integration of technology and technological professions in forms of serial, paralel, serial-paralel and reversible processes can be obtained.

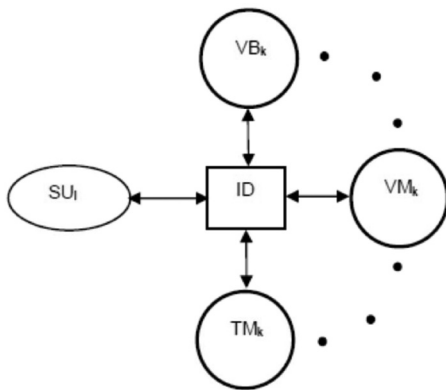

Figure 3 Complex production system

## 5. PRINCIPLES OF DEVELOPMENT

### Compact models

Integrated solutions of production systems on the base of information and material bonds are substantial but not final. Contemporary technical practice requires new solutions representing concentration of functions and activities directly implemented into the integrating device. Thus, at production systems development it is necessary to take into the account also physical bonding of elements and units which is supported by already spread principles of modularity, compatibility and integrity of technical means and means of realization. The results are solutions oriented at compact integrated models developing (fig 4), both on the level of production module or of production cell.

In case of the production module, the starting point is the most often used configuration which is defined by a symbolic model (Fig 4 – case I1). General trend focused at production concentration, combination of several methods and on increase of output parameters leads to the fact that new conceptions of production technique arranged on the base of serial or paralel superstructures enabling to manage integration of technological and handling activities (Fig 4 – case I6) till to the form of production-handling system are used more and more. (Fig 4 – Case I6). The effort to catenate all activities completely not only on the base of production system basic model but also of complex production system leads to application of production-transport systems (Fig 4 – Case I4, I5), whose main task is improvement of compatibility and catenation of individual levels of material flow in production systems with indirect bond or extending of integration at production systems with direct bond [4]. These solutions help create strategy of production company with respect of equivalency and synergy [2] which is generated among individual system functions and parameters and which is invaluable at modification of production system.

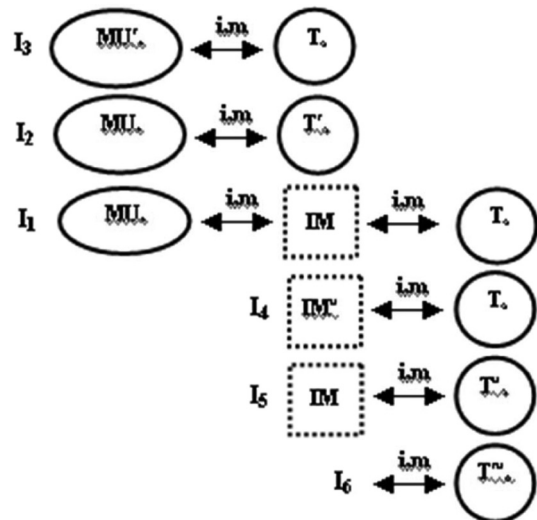

Figure 4 Production module compact integrated models

where:

- $MU_e, IM^u, T_a, T_a^u, T_a^u$  – production module elements and units mutually integrating functions,
- $r, u, ru$  – indicator expressing integration (substitution) of functions ( $r$  – handling device  $u$  – handling junction),
- $a = 1, \dots, o$  – technological device number,
- $e = 1, \dots, p$  – handling junction number.

### Logistic chains

Principles of integration from operational and interoperational level of material flow can be applied also at a central level (Fig 5), but they are also a significant contribution at material flow solutions in framework of complete production-logistic chain. The center of a problem is the fact that integrating device (handling device – IM, transport system – ID) is in one of these forms: as an individual unit, a unit linked to a technological device (T), to a production model (TM, VM, VB), to a storage junction (SU) or as an integral part of these devices. No default configurations of production systems which contribute to

considerable variability of type models structures and which are conditions for new and higher technical-economical effect, from these forms are derived. Actually, these solutions are presented as logictic and they are understood at wider links of information and material flows in pre-production, production and post-production processes.

Production system logistic structure (LVS) integrating material flow within production-logictic chain can be expressed by relations which respond to levels of production system basic model:

- production-handling

$$LVS = \left[ ID_v \xleftrightarrow{i,m,f} \left[ \left\{ T^{ru}_a \right\}_{a=1,\dots,o}, \left\{ SU_l \right\}_{l=1,\dots,s} \right] \right] \quad (3)$$

- production-transfer

$$LVS = \left[ ID^r_v \xleftrightarrow{i,m,f} \left[ \left\{ T^u_a \right\}_{a=1,\dots,o}, \left\{ SU_l \right\}_{l=1,\dots,s} \right] \right]$$

$$LVS = \left[ ID^u_v \xleftrightarrow{i,m,f} \left[ \left\{ T^r_a \right\}_{a=1,\dots,o}, \left\{ SU_l \right\}_{l=1,\dots,s} \right] \right] \quad (4)$$

$$LVS = \left[ ID^{ru}_v \xleftrightarrow{i,m,f} \left[ \left\{ T_a \right\}_{a=1,\dots,o}, \left\{ SU_l \right\}_{l=1,\dots,s} \right] \right]$$

where:

$ID_v$  – compactible transport system,

$ID^r_v, ID^u_v, ID^{ru}_v$  – compact models of compatible shipping-handling system.

$T^r_a, T^u_a, T^{ru}_a$  – compact integrated models of production module mutually integrating functions,

$SU_l$  – storage junction (interoperational, centra, enter-exit storehouse),

$r, u, ru$  – indicator expressing integration of functions ( $r$  – handling device,  $u$  – handling junction),

$a = 1, \dots, o$  – production module number,

$l$  – storage junction number,

$\xleftrightarrow{i,m,f}$  – symbolical expression of information, material and physical communication.

where:

$MU, IM, T, SU, ID, TM, VM, VB$  – building moduls and production system basic models

$*$  – information and material feedback,

$+$  – physical feedback,

$U_1$  – input-output storehouse,

$U_2, \dots, U_n$  – production/assembly cells,

$u_{ij}$  – technological/storage areas.

The defined integration principles (information, material, physical) provide information on ability and extend to integrate

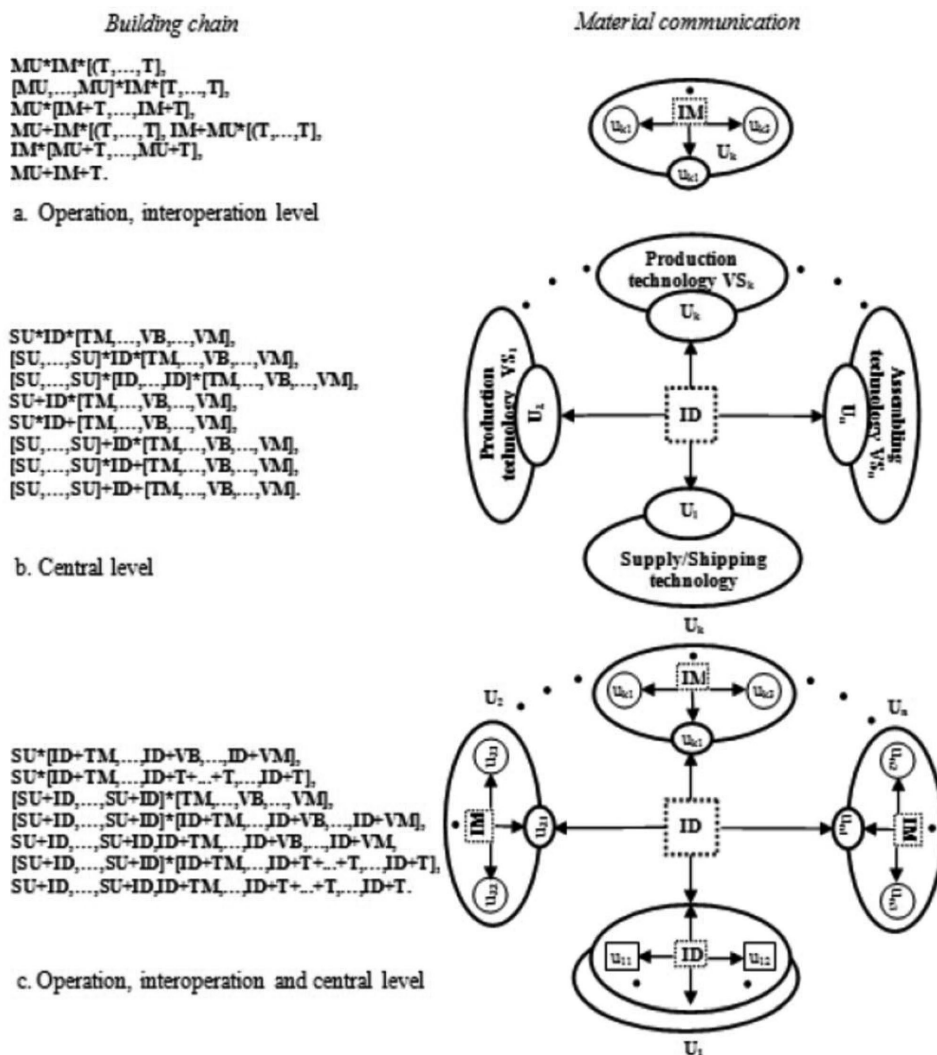

Figure 5 Production system logistic chains



(merge, substitute) technological and handling operations at production system. The integration can also say about reserves in functional (equivalency, system coherence and flexibility), substantial (system elements, modules and sets) and structural (system bonds, composition and stability) component of production system. It can be used not only for optimalization of functional regimes and activities but also for restructulization or design of new production structures and relating problems of controlling, production tasks planning, placement of disposal, and material and information links. [4]

Bringing integrated chains of a production company into reality by logistic structures from now on requires to complete basic levels of knowledge, methods, technique and tools from area of modules of technological and handling technology including its forming into complex production systems.

## 6. CONCLUSION

Machine-controlled production systems logistic structures creating requires a systematical analysis of function and activity of used technical means, trends, their applications in productions and implementing into logistic chain, so that they would be flexible and efficient also at unstable external relations. To fillful this goal means to be able to construct integrated relations within production. The starting point of this is also gradual construction of production structures beginning with the basic model through the complex model and with production system logistic model in the end.

It is important to point out that production systems module configurations are currently considered to be standard already at various kinds of technology (welding, heat processing, inspection, testing and palletization) and they are supported by companies oriented at profits from contemporary logistic technologies as JIT, TQM, group technology, handling groups creating, computerized integrated technolgies at production and circulation.

## REFERENCES

- [1] Huang, H., Chuang, P. Specification, modelling and control of a FMC. JPR, 30, 1992.
- [2] Kováč, M. Tvorba štruktúr RTK (Structure Formation). VUKOV š. p. Prešov, G.R. Mettam, L.B. Adams, How to prepare an electronic version of your article, in: B.S. Jones, R.Z. Smith (Eds.), Introduction to the Electronic Age, E-Publishing Inc., New York, 1999, pp. 281-304.
- [3] Pernica, P. Logistika pro 21. století - Logistics for 21st Century, RADIX, Prague, 2005.
- [4] Valenčík, Š. Integrovaná manipulácia v automatizovanej výrobe - Integrated Handling at Automated Production, Logistika 12/03, Prague, 2003.
- [5] Valenčík, Š. Logistika, technika materiálového toku a integrácia vo výrobných sústavách - Logistics, Material Flow Technology and Integration within Production Systems, AT&P Journal 9/2004, Bratislava, 2004.
- [6] Kučerka, D., Rusnáková, S., Husár, Š., Kučerková, M., Hrmo, R. Research in engineering pedagogy. 16 International Conference on Interactive Collaborative Learning: proceedings. 1. issue. Kazaň: CTI Villach, Kazan. National Research Technological University, 2013, p. 30-35. ISBN 978-1-4799-0152-4.
- [7] Hrmo, R., Kučerka, D., Krištofiaková, L. Developing the Information Competencies via E-learning and Assessing the Qualities of E-learning Text. 15<sup>th</sup> International Conference on Interactive Collaborative Learning and 41<sup>st</sup> International Conference on Engineering Pedagogy. Villach, Austria, pp. 26-28. 2012. ISBN 978-1-4673-2426-7.
- [8] Hrmo, R., Kučerka, D. Information competence and evolution of e-learning text with the fog index. Interactive Collaborative Learning: 14<sup>th</sup> International Conference on Interactive Collaborative Learning (ICL 2011), 2011, p. 390-394. ISBN 978-1-4577-1746-8.
- [9] Pavlenko, S., Halčko, J., Maščenik, J., Nováková, M. Machine Parts Design with PC Support - 1. ed - Prešov: FVT TU, 2008, 347 p. ISBN 978-80-553-0166-2.
- [10] Maščenik, J., Gašpár, Š. Experimental Assessment of Roughness Changes in the Cutting Surface and Microhardness Changes of the Material S 355 J2 G3 after Being Cut by Non-Conventional Technologies In: Advanced Materials Research, 2011, Vol. 314-316, p. 1944-1947. ISSN 1022-6680.
- [11] Gobert, M. The supply of secondary knowledge as a task of the controller in the product creation. Ekonomicko-manazerske spektrum, 2014, Vol. 8, No 2, pp. 69-74. ISSN 1337-0839.
- [12] Vagaská, A., Michal, P., Gombár, M., Kmec, J., Spišák, E., Badida, M. Modelling of the anodizing process of aluminium using neural networks. In Proceedings of the 2014 - 15<sup>th</sup> International Carpathian Control Conference, ICC 2014, 2014. pp. 629-634, ISBN 978-1-4799-3528-4.
- [13] Makarova, I., Khabibullin, R., Belyaev, E., Gabsalikhova, L., Mukhametdinov, E. Improving the logistical processes in corporate service system. Transport Problems, 2016, Vol. 11, Issue 1, pp. 5-108. ISSN 1896-0596. <http://dx.doi.org/10.20858/tp.2016.11.1.1>
- [14] M. Badida, Sobotová, L. The requirements of abrasives and their possibilities in recycling in AWJ Technologies. in: Proc. of 13<sup>th</sup> Int. Multidisciplinary Sci. Geoconference SGEM 2013, 16-22 June, 2013, Albena, Bulgaria. Sofia: STEF92 Technology, pp. 479-486. <http://dx.doi.org/10.5593/sgem2013/bd4/s18.026>
- [15] Fabian, S., Krenický, T. Diagnostic DAQ system developed for prognosis of operational states. in: Proc. of 1<sup>st</sup> Int. Conf. "Vallis Aurea", Pozega 19/09/2008. Polytechnic of Pozega, 2008, pp.183-187.
- [16] Dyczkowska, J. CSR in TSL companies. Transport Problems, 2016, Vol. 10, Issue 1, pp. 97-104. ISSN 1896-0596.