

Title	Continuous-Flow Synthesis of N-Succinimidyl 4-[¹⁸ F]fluorobenzoate Using a Single Microfluidic Chip
Author(s)	Kimura, Hiroyuki; Tomatsu, Kenji; Saiki, Hidekazu; Arimitsu, Kenji; Ono, Masahiro; Kawashima, Hidekazu; Iwata, Ren; Nakanishi, Hiroaki; Ozeki, Eiichi; Kuge, Yuji; Saji, Hideo
Citation	PLOS ONE (2016), 11(7)
Issue Date	2016-07-13
URL	http://hdl.handle.net/2433/218702
Right	© 2016 Kimura et al. This is an open access article distributed under the terms of the Creative Commons Attribution License, which permits unrestricted use, distribution, and reproduction in any medium, provided the original author and source are credited.
Type	Journal Article
Textversion	publisher

RESEARCH ARTICLE

Continuous-Flow Synthesis of *N*-Succinimidyl 4-¹⁸F]fluorobenzoate Using a Single Microfluidic Chip

Hiroyuki Kimura^{1,2*}, Kenji Tomatsu¹, Hidekazu Saiki³, Kenji Arimitsu^{1,4}, Masahiro Ono¹, Hidekazu Kawashima^{1,5}, Ren Iwata⁶, Hiroaki Nakanishi³, Eiichi Ozeki³, Yuji Kuge^{1,7}, Hideo Saji^{1*}

1 Graduate School of Pharmaceutical Sciences, Kyoto University, Kyoto, Kyoto, Japan, **2** Department of Analytical and Bioinorganic Chemistry, Kyoto Pharmaceutical University, Kyoto, Kyoto, Japan, **3** Technology Research Laboratory, Shimadzu Corporation, Souraku-gun, Kyoto, Japan, **4** School of Pharmacy and Pharmaceutical Sciences, Mukogawa Women's University, Nishinomiya, Hyogo, Japan, **5** Radioisotope Research Center, Kyoto Pharmaceutical University, Kyoto, Kyoto, Japan, **6** CYRIC, Tohoku University, Sendai, Miyagi, Japan, **7** Central Institute of Isotope Science, Hokkaido University, Sapporo, Hokkaido, Japan

* hsaji@pharm.kyoto-u.ac.jp (HS); hkimura@mb.kyoto-phu.ac.jp (HK)



OPEN ACCESS

Citation: Kimura H, Tomatsu K, Saiki H, Arimitsu K, Ono M, Kawashima H, et al. (2016) Continuous-Flow Synthesis of *N*-Succinimidyl 4-¹⁸F]fluorobenzoate Using a Single Microfluidic Chip. PLoS ONE 11(7): e0159303. doi:10.1371/journal.pone.0159303

Editor: Juri G. Gelovani, Wayne State University, UNITED STATES

Received: March 11, 2016

Accepted: June 30, 2016

Published: July 13, 2016

Copyright: © 2016 Kimura et al. This is an open access article distributed under the terms of the [Creative Commons Attribution License](https://creativecommons.org/licenses/by/4.0/), which permits unrestricted use, distribution, and reproduction in any medium, provided the original author and source are credited.

Data Availability Statement: All relevant data are within the paper and its Supporting Information files.

Funding: This work was supported by the New Energy and Industrial Technology Development Organization (P08029, H. Saji, http://www.nedo.go.jp/activities/ZZ_00259.html). The funders had no role in study design, data collection and analysis, decision to publish, or preparation of the manuscript. Shimadzu Corporation provided support in the form of the salaries for authors, H. Saiki, H. Nakanishi and E. Ozeki, but did not have any additional role in study design, data collection and analysis, decision to publish, or preparation of the manuscript. The specific

Abstract

In the field of positron emission tomography (PET) radiochemistry, compact microreactors provide reliable and reproducible synthesis methods that reduce the use of expensive precursors for radiolabeling and make effective use of the limited space in a hot cell. To develop more compact microreactors for radiosynthesis of ¹⁸F-labeled compounds required for the multistep procedure, we attempted radiosynthesis of *N*-succinimidyl 4-¹⁸F]fluorobenzoate (¹⁸F]SFB) via a three-step procedure using a microreactor. We examined individual steps for ¹⁸F]SFB using a batch reactor and microreactor and developed a new continuous-flow synthetic method with a single microfluidic chip to achieve rapid and efficient radiosynthesis of ¹⁸F]SFB. In the synthesis of ¹⁸F]SFB using this continuous-flow method, the three-step reaction was successfully completed within 6.5 min and the radiochemical yield was 64 ± 2% (*n* = 5). In addition, it was shown that the quality of ¹⁸F]SFB synthesized on this method was equal to that synthesized by conventional methods using a batch reactor in the radiolabeling of bovine serum albumin with ¹⁸F]SFB.

Introduction

Positron emission tomography (PET) [1] is a powerful non-invasive imaging technology for investigating physiological parameters in living human and animal whole bodies using molecular probes labeled with PET radioisotopes. The development and preparation of such radiolabeled molecules is a major synthetic challenge because of the short half-lives of positron-emitting radionuclides such as ¹⁸F, ¹¹C, ¹³N, and ¹⁵O.

roles of these authors are articulated in the 'author contributions' section.

Competing Interests: The authors have declared that no competing interests exist. Shimadzu Corporation does not alter the authors' adherence to PLOS ONE policies on sharing data and materials.

Microfluidic technologies have many advantages for the rapid synthesis of short-lived radio-pharmaceuticals for PET. A microreactor is a synthesizer that allows reactions to occur inside microchannels at the nanoliter/microliter scale. The large specific surface area enables effective heat conduction, and the short diffusion distances reduce mixing times. The short reaction times and good chemical yields [2] achieved using microreactors have attracted a high level of interest in PET radiochemistry. Microreactors are also suitable for handling and reacting small amounts of reagents and are therefore appropriate for the synthesis of expensive precursors or tracer compounds, which may be in limited supply [3–7]. Furthermore, radiochemical reactions performed on a compact microfluidic chip can be easily shielded. A compact microfluidic chip does not require the space and resources required by conventional synthesizers [8–10].

The use of microreactors in single-step radiolabeling (e.g., ^{18}F and ^{11}C) [11–14] and the production of PET probes [15–24] have been reported. Many recently developed PET probes involve lengthy, multistep, and inefficient synthetic procedures because the parent skeleton of probes has become diversified. Therefore, the development of a microreactor that can perform a multistep synthesis is desirable.

Two types of approaches, continuous-flow and batch-mode microreactors, have been attempted for multistep synthesis of radiopharmaceuticals. In case of continuous-flow systems, several microreactor-included microfluidic chips have been used (Fig 1a) [17–28]. However, these systems have the following disadvantages: 1) multiple microfluidic chips are necessary, 2) there are large dead volumes between the microfluidic chips, and 3) the control systems are complicated. To address these problems, we have attempted to develop a continuous-flow synthetic method in a multistep reaction using a single microfluidic chip (Fig 1b).

Many clinical PET probes incorporate ^{18}F . From a PET synthetic perspective, the half-life of ^{18}F is sufficiently long to enable multistep synthesis. The radiosynthesis of *N*-succinimidyl 4- ^{18}F fluorobenzoate (^{18}F SFB) [29–36] was selected as the model reaction for multistep synthesis evaluation because ^{18}F SFB is a well-known prosthetic group for peptides, proteins, and antibodies in PET radiochemistry. The synthesis of ^{18}F SFB requires the following three steps: 1) ^{18}F fluorination of an aromatic precursor, i.e., 4-(*tert*-butoxycarbonyl)-*N,N,N*-trimethylphenylammonium triflate (**1**) [31], 2) hydrolysis of *tert*-butyl 4- ^{18}F fluorobenzoate (**2**) with tetrapropylammonium hydroxide (TPAH), and 3) succinimidylation of the 4- ^{18}F fluorobenzoic acid (**3**) with *O*-(*N*-succinimidyl)-*N,N,N,N'*-tetramethyluronium tetrafluoroborate (TSTU) [30,31] (Fig 2). To date, attempts have been made to reduce the time required to synthesize ^{18}F SFB and to improve the yields using modified commercial synthesizers and microwave synthetic technology; [34–36] however, further improvements are desired.

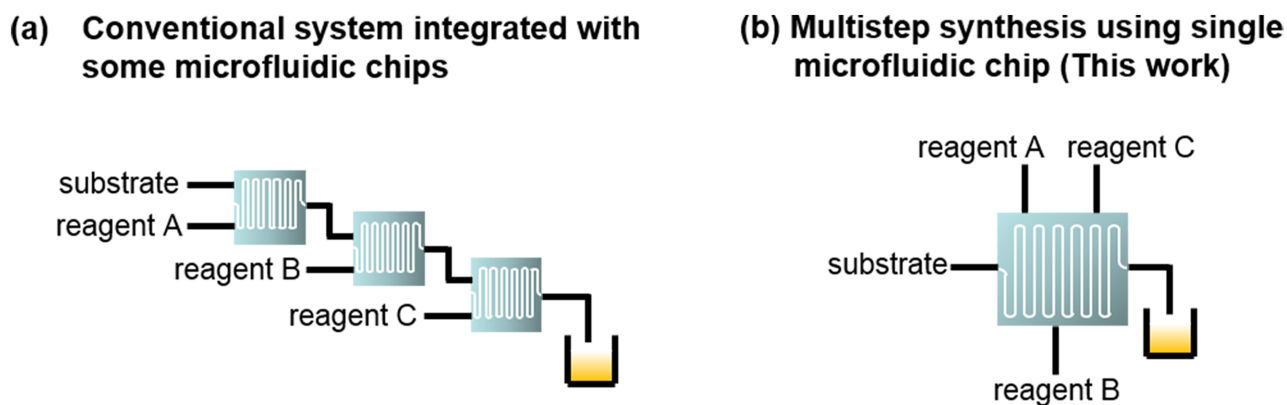

Fig 1. Concepts for microfluidic syntheses that require multistep reactions.

doi:10.1371/journal.pone.0159303.g001

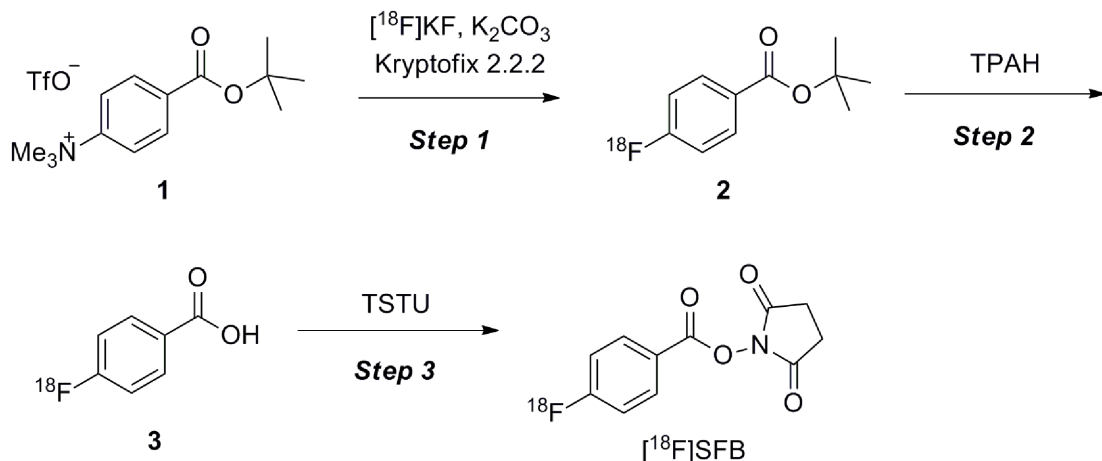

Fig 2. Synthetic method for $[^{18}\text{F}]\text{SFB}$.

doi:10.1371/journal.pone.0159303.g002

Materials and Methods

General Experimental

Analytical and preparative high-performance liquid chromatography (HPLC) was performed using a Shimadzu LC-20AD (Shimadzu Corporation, Kyoto, Japan) solvent delivery system at a flow rate of 1.0 mL/min and with SPD-10AP (Shimadzu Corporation) UV detector (254 nm) and Aloka NDW-351D (Hitachi Aloka Medical, Ltd., Tokyo, Japan) RI detector. A Cosmosil 5C₁₈-PAQ column (4.6 × 150 mm, Nacalai Tesque Inc., Kyoto, Japan) was used for reverse-phase HPLC. Conditions for HPLC are defined as follows: condition 1) MeCN/water = 55/45; condition 2) MeCN:ammonium acetate buffer (50 mM, pH 4.0) = 25:75 (over 7 min), gradually adjusted to 80:20 (over 8 min), and followed by 80:20; condition 3) MeCN:ammonium acetate buffer (50 mM, pH 4.0) = initiated from 25:75, gradually adjusted to 80:20 (over 20 min), and followed by 80:20. A part of the reaction mixture was purified by HPLC to give the solution of ^{18}F -labeled products. From the radioactivity of the resulting solution, the decay-corrected conversion yields were calculated with the following formula: conversion yield (%) = (decay-corrected radioactivity of ^{18}F -labeled products obtained by radio-HPLC purification/radioactivity of ^{18}F loaded into the radio-HPLC) × 100. The radioactivity of ^{18}F was measured using a curie-meter (IGC-3, Aloka) or NaI (Tl) gamma scintillation counter (Cobra Auto-Gamma Counter 5003, Perkin-Elmer (Packard), Waltham, MA, USA). A screw-cap pressure vessel was used as a batch reactor (purchased from Oofuna, Ltd., Osaka, Japan) [37]. Most chemicals were reagent-grade, purchased from Merck (Darmstadt, Germany) and Sigma-Aldrich (St. Louis, MO, USA), and used without further purification. Precursor **1** and *N*-succinimidyl fluorobenzoate (non-radioactive SFB) [31] were synthesized according to a previously published procedure [30,31].

Preparation of $[^{18}\text{F}]\text{fluoride}$ ion

$[^{18}\text{F}]\text{Fluoride}$ ion was produced using a cyclotron (CYPRIS HM-18, Sumitomo Heavy Industries, Tokyo, Japan) via an $^{18}\text{O}(p,n)^{18}\text{F}$ reaction and passed through a Sep-Pak Light QMA cartridge (Waters Corporation, Milford, MA, USA) as an aqueous solution in ^{18}O -enriched water. The cartridge was dried in an air-flow, and the ^{18}F -active material was eluted with an aqueous solution of K_2CO_3 (33 mM, 0.5 mL).

[¹⁸F]Fluorination (step 1) using batch reactor

An aqueous solution of ¹⁸F⁻ (ca. 37 MBq, 100–500 μL, containing 33 mM K₂CO₃) was added to a solution of Kryptofix 2.2.2 (10 mg) in MeCN (500 μL). The solvent was removed under a stream of argon gas at 110°C. Azeotropic drying was repeated three times with 400 μL portions of MeCN to give full dehydration. A solution of **1** (1 mg) in DMSO (1 mL) was added to the mixture, and the reaction was heated at 120°C for 1, 3, 5, 10, or 15 min. The reaction was quenched by the mixture solution of DMSO and water (50/50). The mixture was purified by preparative radio-HPLC (condition 1) to give a solution of pure **2** (R_t = 11.0 min). The radioactivity of ¹⁸F was determined using an NaI (TI) gamma scintillation counter. Data are the mean ± S.D. (*n* = 5) decay corrected.

Hydrolysis of **3** (step 2) using batch reactor

An aqueous solution of TPAH (1 M, 4 μL) was diluted with DMSO (96 μL), and the solution was added to a solution of **2** (prepared by step 1) in DMSO (100 μL). The mixture was heated at 120°C for 5, 30, and 60 s. The reaction was quenched by an aqueous solution of 0.5% acetic acid, and the mixture was purified by preparative radio-HPLC (condition 2) to give a solution of pure **3** (R_t = 10.7 min). The radioactivity of ¹⁸F was determined using an NaI (TI) gamma scintillation counter. Data are the mean ± S.D. (*n* = 4) decay corrected.

Microreactor system

The microreactor system developed in this study, including the pump system, chip stage, heat controller, and operating soft, was manufactured by Shimadzu Corporation. The jig used to secure the microfluidic chip was placed onto a heating plate for the reaction, and the temperature was controlled using feedback from a laminated sensor on the chip (Fig 3).

Microfluidic chip designed for single-step reaction (chip 1)

Chip 1 was formed by bonding two glass substrates. Reaction channel **E**, reagent injection ports (inlet **A**, **B**), a liquid discharge port (outlet **D**), and a reaction-stop reagent injection port (inlet **C**) to channel **E** were formed. The channels and through holes were formed by sandblasting, and the glass substrates were bonded using hydrofluoric acid. The width of reaction channel **E** and the connection channels was 150 μm, and the depth was 150 μm. The length of reaction channel **E** was 250 mm, and the volumetric capacity was 5.625 μL (Fig 4). In addition, the surface temperature of chip 1 placed on heating plate was monitored at several points using a data logger (NR-1000, Keyence, Osaka, Japan) and thermograph (Thermo-Tracer 6T61, NEC San-ei, Tokyo, Japan).

Diffusional efficiency in microfluidic chip (for chip 1). To evaluate the diffusional efficiency in our microfluidic chip, both DMSO and black-colored DMSO were introduced into chip 1 (designed for single-step reaction) through inlet **A** and **B**, respectively. The total flow rate was 33.76 μL/min (residence time: 10 s). When the chip was heated to 120°C on a heating plate, the solution state at three points of the flow-channel was observed by a stereomicroscope (STZ-168-TL, Shimadzu Corporation, Kyoto, Japan).

[¹⁸F]Fluorination (step 1) using microreactor

A solution of **1** (1 mg) in DMSO (500 μL) was introduced into the chip 1 through inlet **A**. An aqueous solution of ¹⁸F⁻ (ca. 37 MBq, 100–500 μL, containing 33 mM K₂CO₃) and a solution of Kryptofix 2.2.2 (10 mg) in MeCN (500 μL) were azeotropically dehydrated in the same manner as the above dehydration. Following this, the mixture was dissolved in DMSO (500 μL) and

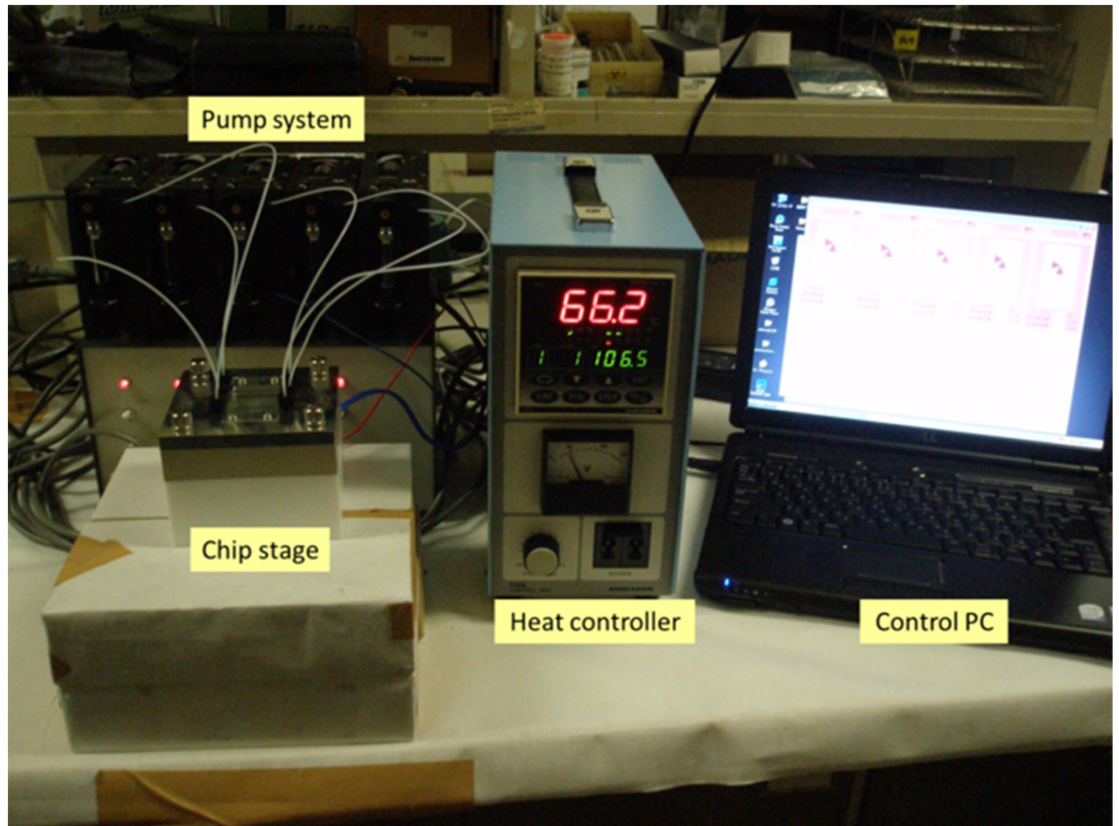
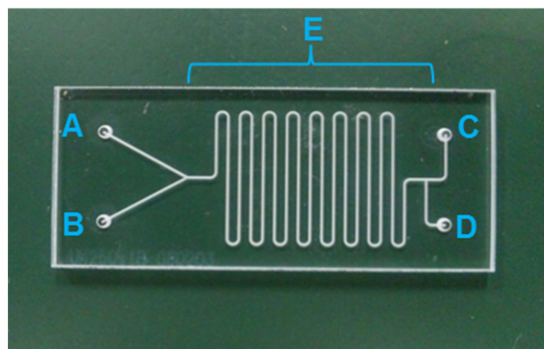

Fig 3. Microreactor system developed in this study.

doi:10.1371/journal.pone.0159303.g003

introduced through inlet **B**. The reaction was performed on chip 1 heated at 120°C. A mixture solution of DMSO and water (80/20) was introduced through inlet **C** as a quenching reagent. The reaction mixture collected from outlet **D** was purified in the same manner as that for the batch reactor. The radioactivity of ^{18}F was determined using a NaI (Tl) gamma scintillation counter. Data are the mean \pm S.D. ($n = 5$) decay corrected.



chip size : 45 x 20 mm
 volume : 5.625 μL
 cross-section of channel

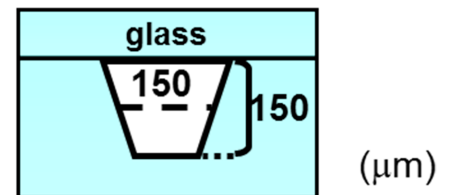

Fig 4. Design of chip 1 for a single reaction.

doi:10.1371/journal.pone.0159303.g004

Hydrolysis of 3 (step 2) using microreactor

A solution of **2** (prepared by step 1) in DMSO (100 μL) was introduced into chip 1 through inlet **A**. An aqueous solution of TPAH (1 M, 4 μL) was diluted with DMSO (96 μL), and the solution was introduced through inlet **B**. An aqueous solution of 0.5% acetic acid was injected through inlet **C** to quench the reaction.

The reaction mixture collected from outlet **D** was purified in the same manner as that for the batch reactor to give a solution of pure **3** ($R_t = 10.7$ min). The radioactivity of ^{18}F was determined using a NaI (Tl) gamma scintillation counter. Data are the mean \pm S.D. ($n = 4$) decay corrected.

Evaluation of effect of water content for succinimidylation (step 3) (using batch reactor)

The mixture of $^{18}\text{F}^-$ (ca. 37 MBq, 100–500 μL , containing 33 mM K_2CO_3) and Kryptofix 2.2.2 (10 mg) in MeCN (500 μL) was azeotropically dehydrated in the same manner as the above dehydration. A solution of precursor **1** (5 mg) in MeCN (1 mL) was added to the mixture, and the reaction was performed at 90°C for 10 min. An aqueous solution of TPAH (1 M, 20 μL) was added, and the reaction was performed at 120°C for 5 min to give intermediate **3**. After the reaction mixture was azeotropically dehydrated with MeCN, the mixture was dissolved in MeCN and reacted with TSTU to synthesize $[^{18}\text{F}]\text{SFB}$. The reaction solutions were also adjusted to 1.6%–51% of water content and reacted with TSTU. The mixture was purified by preparative HPLC (condition 3) to give a solution of pure $[^{18}\text{F}]\text{SFB}$ ($R_t = 11.0$ min). The radioactivity of ^{18}F was determined using a NaI (Tl) gamma scintillation counter. Data are the mean \pm S.D. ($n = 5$) decay corrected.

Microfluidic chip designed for three-step reaction (chip 2)

Chip 2 was formed by bonding two glass substrates. Reaction channels (**H**, **J**, and **L**) and channels for connecting the raw material injection port, a liquid discharge port (outlet **M**), a quenching reagent injection port (inlet **N**), and injection ports (inlet **F**, **G**, **I**, and **K**) to inject various reagents into the reaction channel were formed. The channels and through holes were formed by sandblasting, and the glass substrates were bonded using hydrofluoric acid. The width of the reaction channels **H**, **J**, and **L**, and the connection channels was 150 μm , and the depth was 150 μm . The length of the first-step reaction channel **H** was 250 mm and its volumetric capacity was 5.625 μL . The length of the second-step reaction channel **J** was 50 mm and its volumetric capacity was 1.125 μL . The length of the third-step reaction channel **L** was 200 mm, and its volumetric capacity was 4.5 μL (Fig 5). As is the case in chip 1, the surface temperature of chip 2 placed on heating plate was monitored at several points using a data logger and thermograph.

Continuous-flow synthesis of $[^{18}\text{F}]\text{SFB}$ using a microreactor

Kryptofix 2.2.2 (10 mg) and $^{18}\text{F}^-$ (ca. 37 MBq) were azeotropically dehydrated, dissolved in DMSO (500 μL), and introduced into chip 2 through inlet **A** at flow rate of 0.56 $\mu\text{L}/\text{min}$. A solution of **1** (1 mg) in DMSO (500 μL) was set on inlet **B** and introduced at flow rate of 0.56 $\mu\text{L}/\text{min}$. A diluted solution of TPAH (1 M aqueous solution, 40 μL) with DMSO (500 μL) and a solution of TSTU (15 mg) in DMSO (500 μL) were set on inlet **I** and **K** and then introduced at flow rates of 1.12 and 2.24 $\mu\text{L}/\text{min}$, respectively. The reaction was performed on chip 2 heated at 120°C, and reaction times of step 1, 2, and 3 were 5 min, 30 s, and 1 min, respectively. DMSO/water (90/10) was introduced through inlet **N** as a quenching reagent.

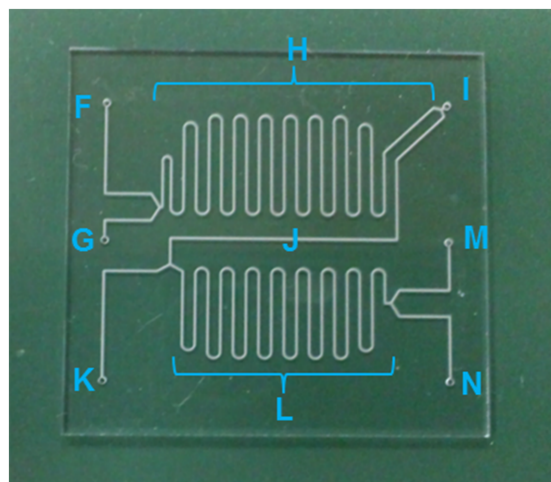

J : channel from inlet **I** to the junction

Fig 5. Design of chip 2 for a three-step reaction.

doi:10.1371/journal.pone.0159303.g005

material : silica glass
fabrication : sandblast
chip size : 50 x 50 mm
volume : 5.6, 1.1, 4.5 μL

cross-section of channel

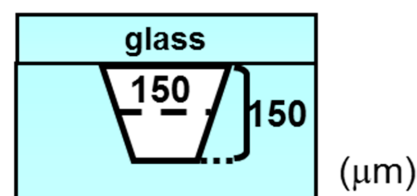

The mixture was purified by preparative HPLC (condition 3) to give a solution of pure [^{18}F]SFB (Rt = 11.0 min). The radioactivity of ^{18}F was determined using a NaI (Tl) gamma scintillation counter. Data are the mean \pm S.D. ($n = 5$) decay corrected.

Radiolabeling of BSA with [^{18}F]SFB

After the synthesis of [^{18}F]SFB using chip 2, the overall mixture collected from outlet **M** was diluted with 5% acetic acid and applied to a Sep-Pak Accell Plus CM Cartridge (Waters Corporation). A Sep-Pak PS-2 Plus Cartridge (Waters Corporation) was attached to the Sep-Pak Accell Plus CM Cartridge, and the cartridges were washed with 20 mL of MeCN/water (20/80). After flowing N_2 gas for 10 s, the Sep-Pak Accell Plus CM Cartridge was removed. [^{18}F]SFB was eluted from the Sep-Pak Plus PS-2 Cartridge with 2.0 mL of MeCN. The isolated radiochemical yield was measured using a curiemeter. MeCN was removed under a stream of argon at 50°C. After drying, [^{18}F]SFB was dissolved in sodium borate buffer solution (0.05 M, pH 8.5: solution I). BSA was dissolved in sodium borate buffer solution (0.05 M, pH 8.5, 20 mg/mL: solution II). For the microreactor reaction, solution I and II were run into inlets **A** and **B** on chip 1 at a flow rate of 0.56 $\mu\text{L}/\text{min}$ at 37°C. The reaction was stopped by adding 0.01 M HCl solution. The reaction mixture was analyzed using the electrophoresis (0.8 mA/cm, 45 min). The position of radiolabeled BSA was previously confirmed by Ponceau staining. The filter paper was then cut equally. The radioactivity was measured by an NaI (Tl) gamma scintillation counter, and the conversion yield was calculated from the radioactivity of [^{18}F]SFB. Data are the mean \pm S.D. ($n = 4$) decay corrected.

Results and Discussion

To apply the three-step reaction of [^{18}F]SFB to a continuous-flow synthetic method using a single microfluidic chip, we initially examined ^{18}F -fluorination, which is the first step of radiosynthesis of [^{18}F]SFB (Fig 2). A solution of **1** in dimethyl sulfoxide (DMSO) was run into inlet **A**, and a mixture of [^{18}F]KF and Kryptofix 2.2.2 in DMSO was run into inlet **B** on the designed microfluidic chip (chip 1) pre-heated at 120°C (Fig 6a). After passing channel **E**, which is regarded as a reaction field, the mixture was quenched by the solvent injected through inlet **C**.

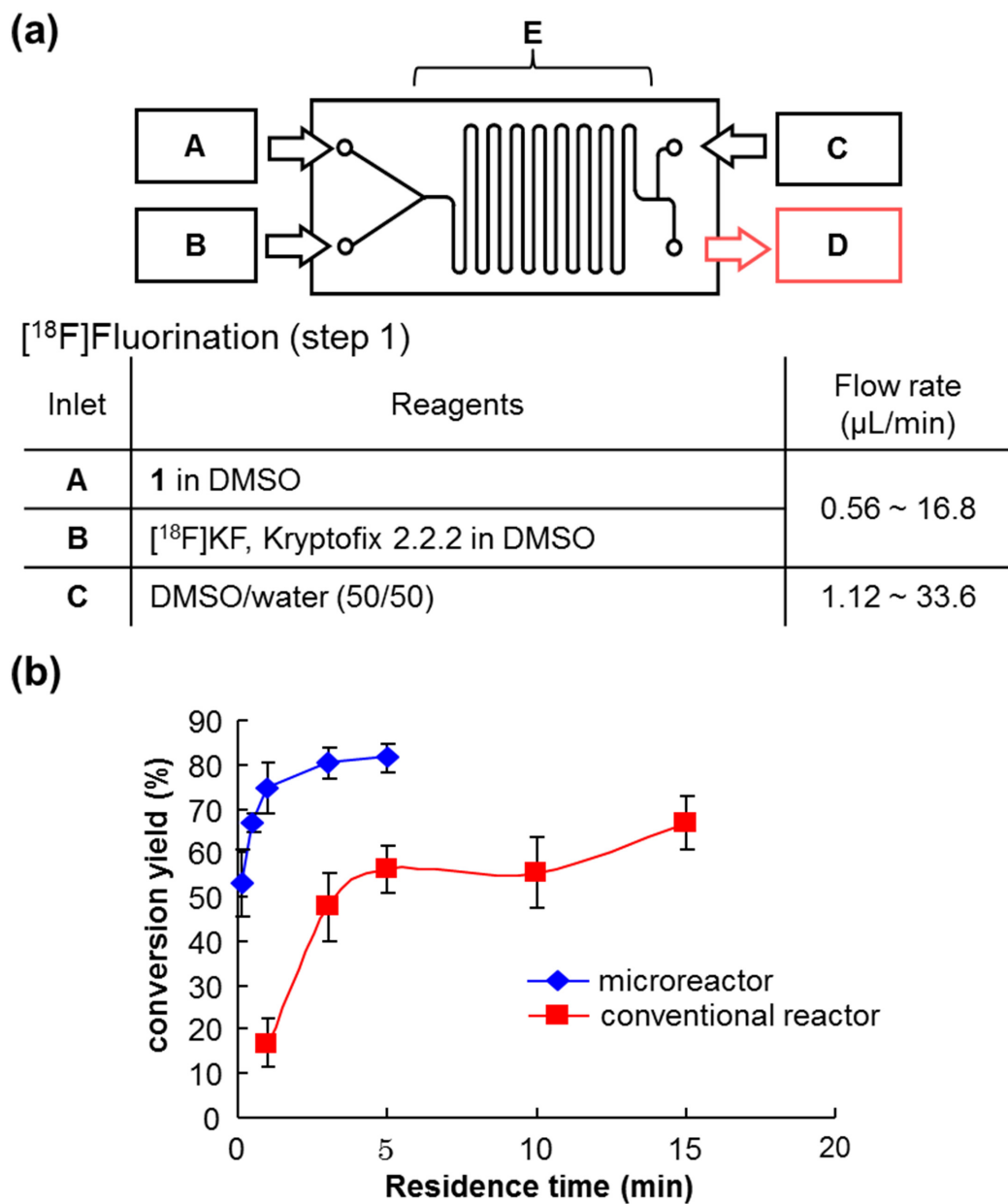

Fig 6. (a) Procedure for [¹⁸F]fluorination (step 1) using microreactor with chip 1. (b) Comparison with microreactor (data are the mean ± S.D., *n* = 5) and batch reactor (data are the mean ± S.D., *n* = 4).

doi:10.1371/journal.pone.0159303.g006

The optimal reaction time (residence time) was established by the change in the flow rate. The conversion yield of **2** reached $75 \pm 6\%$ (*n* = 5) in less than 1 min and $81 \pm 3\%$ (*n* = 5) at 5 min. The use of a batch reactor under oil bath heating condition gave a conversion of $56 \pm 5\%$ (*n* = 4) at 5 min and $67 \pm 6\%$ (*n* = 4) at 15 min (Fig 6b). The conversion yield was higher with the microreactor at 5 min than with the batch reactor at 15 min.

Following this, the effectiveness of the microreactor for hydrolysis of ester **2**, which was prepared using a batch reactor, was examined (Fig 7a). Treatment of **2** with an aqueous solution of TPAH in DMSO on chip 1 gave **3** rapidly and quantitatively. Fig 7b shows that there was little

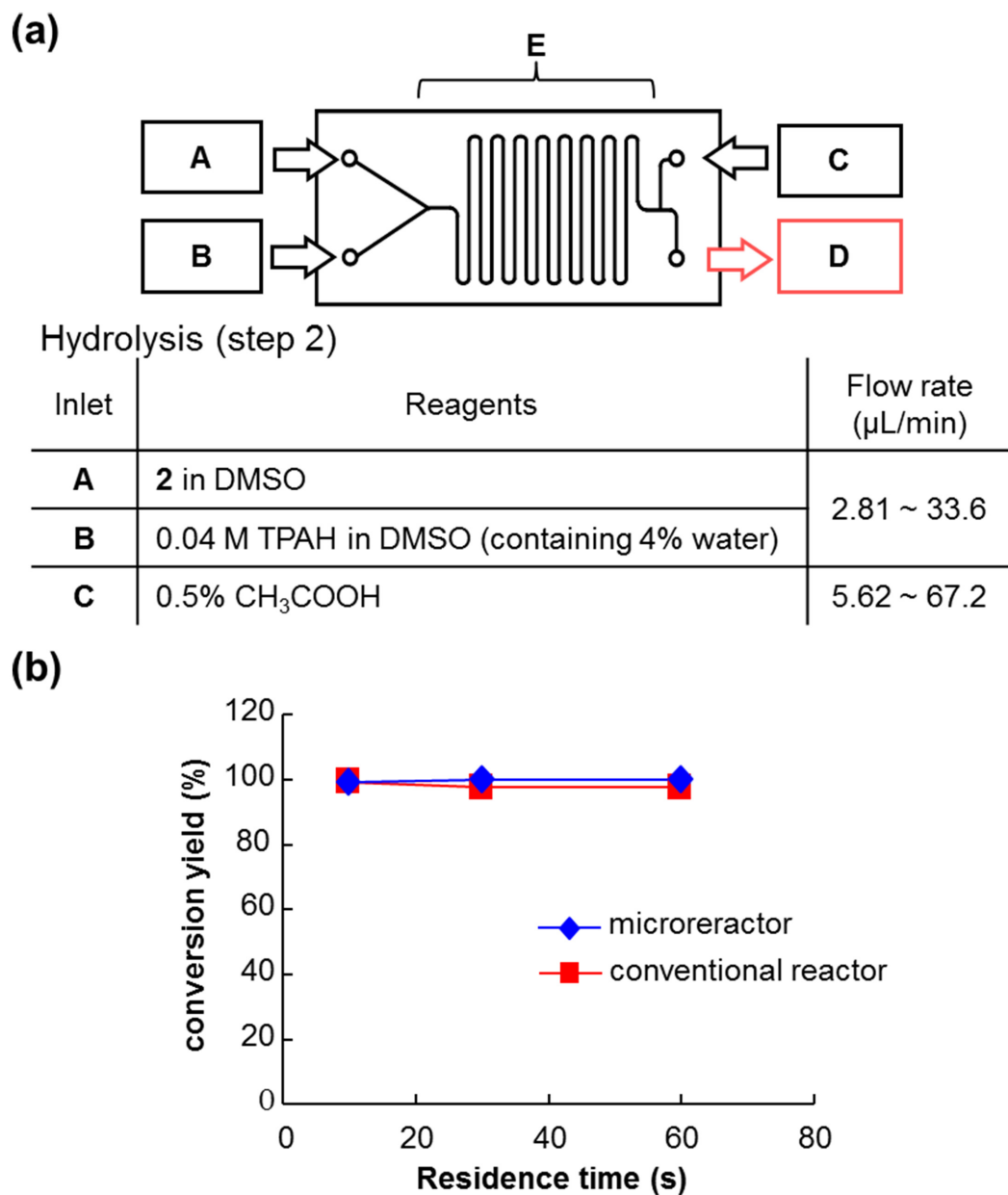

Fig 7. (a) Procedure for hydrolysis (step 2) using microreactor with chip 1. (b) Comparison with microreactor (data are the mean \pm S.D., $n = 4$) and batch reactor (data are the mean \pm S.D., $n = 4$).

doi:10.1371/journal.pone.0159303.g007

difference between the reaction using the microreactor and the batch reactor. This result suggests that the hydrolysis of **2** progresses easily.

We then attempted to examine succinimidylation (step 3) using the microreactor. However, [¹⁸F]**2** was difficult to isolate because of its high volatility. Hence, we investigated the succinimidylation of **3** without any treatment after hydrolysis. In one-pot radiosynthesis of [¹⁸F]SFB using a batch reactor, the mixture obtained after hydrolysis is azeotropically dehydrated and then allowed to react with TSTU to give [¹⁸F]SFB [34]. Bannwarth et al. have reported that succinimidylation with only a slight excess of TSTU is rapid and clean, even in the presence of water [38]. To apply continuous-flow synthesis using a microreactor, we investigated

simplification of the procedure by omitting the dehydration process. In our synthetic strategy, a solution of TPAH in DMSO involving 4% water was used in the above hydrolysis process using a microreactor. Therefore, when the solution of TPAH in DMSO is used without any treatment for succinimidylation, the water content is 2%. To evaluate the effect of the water content on succinimidylation, one-pot radiosynthesis of [^{18}F]SFB was performed using a batch reactor. Acid **3** was prepared using a previously reported method [34] and then reacted with TSTU in MeCN containing 1.6% to 51% water at 90°C. The conversion yield of [^{18}F]SFB did not decrease significantly even when the water content of the reaction solution was as much as 50% (Fig 8). Therefore, the azeotropic dehydration step after hydrolysis could be omitted under our synthetic conditions.

To simplify the system, it is preferable if the reaction temperature in a multistep reaction run with a single microfluidic chip is the same for all steps. Thus, the reaction temperatures for the three-step reaction were standardized using one-pot synthesis of [^{18}F]SFB in a batch reactor with either acetonitrile (MeCN) or DMSO as the solvent. Reaction times of 10, 5, and 2 min were set for [^{18}F]fluorination, hydrolysis, and succinimidylation, respectively, and the corresponding reagents were successively added to a solution of **1** in MeCN at three reaction temperatures, i.e., 70, 80, and 90°C, respectively (Fig 9a). [^{18}F]SFB was obtained with 33% of conversion yield at 90°C using a one-pot procedure; in addition, the residual intermediate ester **2** was observed at 8%. It was confirmed that at temperatures greater than 100°C, MeCN began to leak at the joint with the microfluidic chip in the microreactor. When DMSO was used, four reaction temperatures, i.e., 70, 80, 90, and 120°C, were tested (Fig 9b). [^{18}F]SFB was obtained

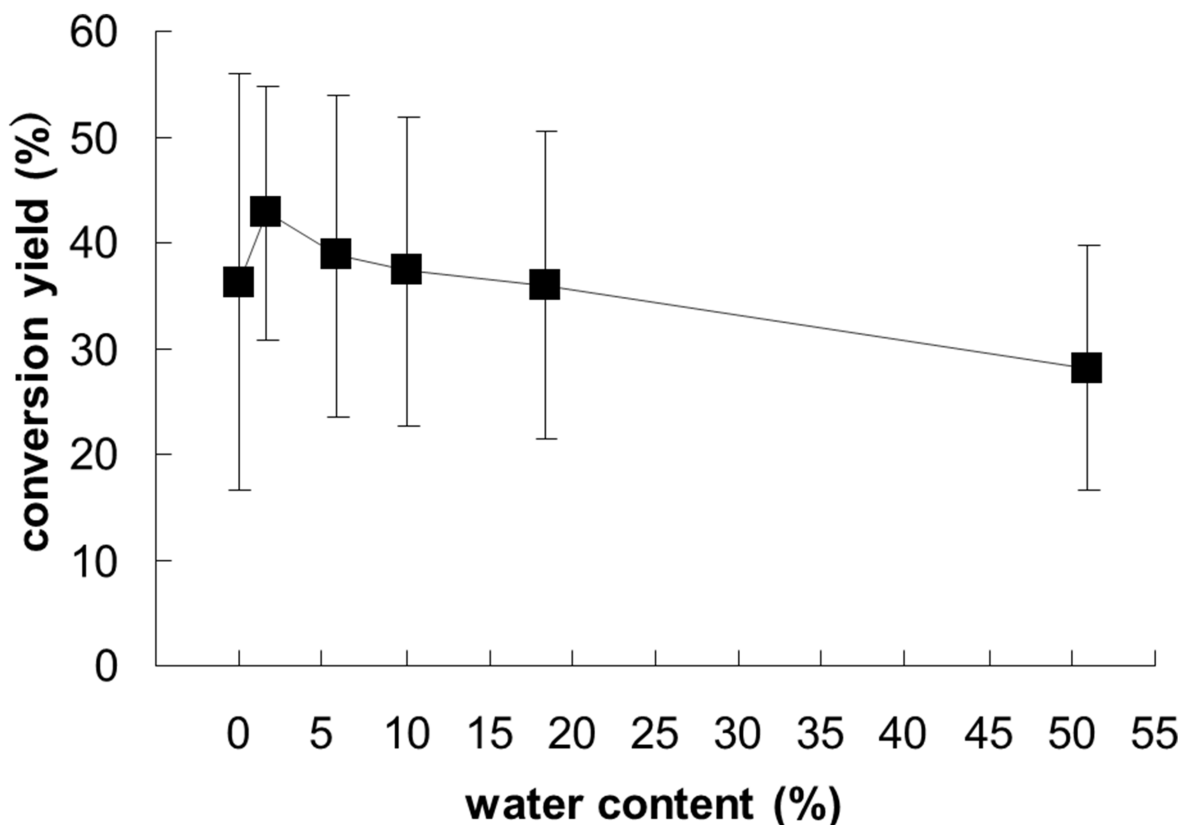

Fig 8. Radiochemical yield of [^{18}F]SFB by one-pot radiosynthesis under different water content conditions (data are the mean \pm S.D., $n = 3$).

doi:10.1371/journal.pone.0159303.g008

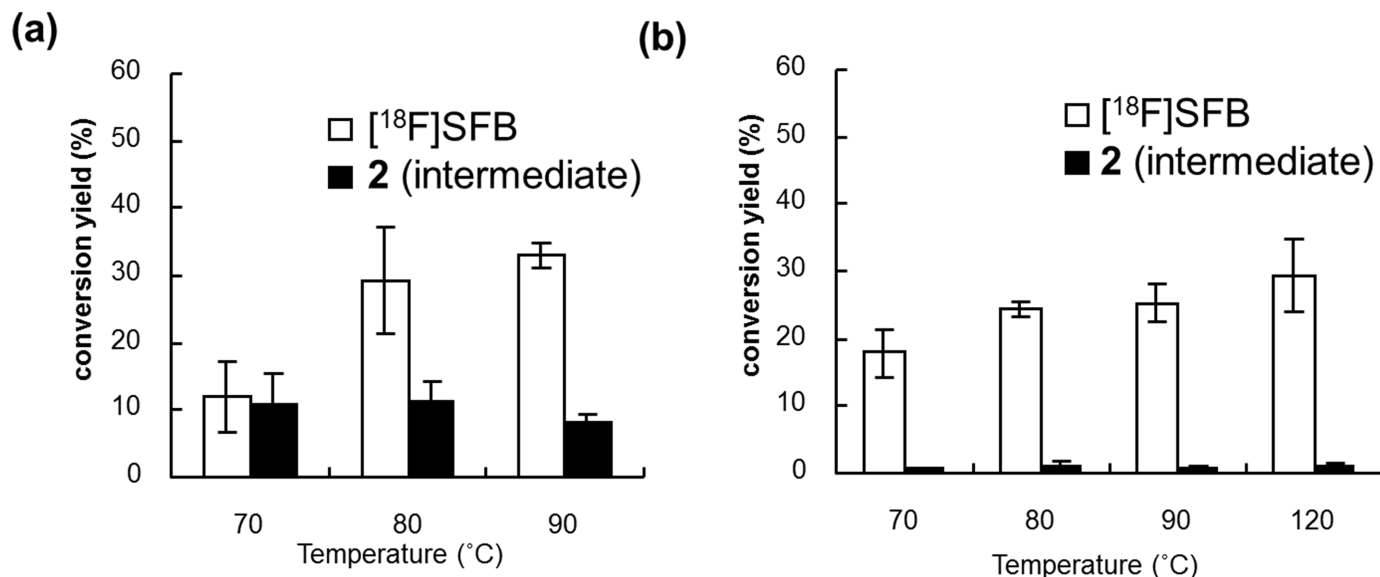

Fig 9. One-pot synthesis of [¹⁸F]SFB in (a) MeCN or (b) DMSO using a batch reactor (data are the mean ± S.D., *n* = 3).

doi:10.1371/journal.pone.0159303.g009

with 29% of conversion yield at 120°C and the amount of residual **2** was less (<1%) at all temperatures, and the production of [¹⁸F]SFB was promoted at higher temperatures. It was confirmed that DMSO began to leak at the joint at temperatures greater than 120°C. Therefore, we chose DMSO as the solvent and 120°C as the set temperature.

Based on the results, we designed a 50-mm × 50-mm microfluidic chip (chip 2) with a total flow channel of length 500 mm (Fig 5) for the three-step reaction. Chip 2 had five inlets along the entire channel and one outlet. The channel lengths were 250 mm for step 1, 50 mm for step 2, and 200 mm for step 3. Based on the reaction times for steps 1 and 2 on chip 1, **1** and the ¹⁸F-labeling reagent in DMSO were run into inlets F and G at a flow rate of 0.56 μL/min for [¹⁸F]fluorination, respectively (Fig 10a). At 5 min after the beginning of the reaction, TPAH was run into inlet I at a flow rate of 1.12 μL/min, and after another 30 s, TSTU was run into inlet K at 2.24 μL/min. DMSO/water (90/10) was introduced into the reaction stop reagent injection port N to stop the reaction. Thus, the reaction times were 5 min for ¹⁸F-fluorination, 30 s for hydrolysis, and 1 min for succinimidylation. Chip 2 was placed on an aluminum chip holder equipped with a built-in ceramic heater to perform reactions at a predetermined temperature. When the microreactor was heated, the surface temperature of chip 2 was measured using a thermocouple and thermography. Chip 2 was heated to a uniform temperature (± 5°C) to set the temperature (see Electronic Supporting Information). The three-step reaction for [¹⁸F]SFB on chip 2 was successfully completed within 6.5 min of residence time. The conversion yield was 64 ± 2% (*n* = 5); the yield rate and reaction efficiency are substantially better than those of the one-pot synthetic method [reaction time 17 min, 48 ± 9% (*n* = 6) conversion yield]. These results show that the use of the developed microreactor gave a higher radiochemical yield of [¹⁸F]SFB with a shorter reaction time than the use of the one-pot synthetic method.

To evaluate the quality of the [¹⁸F]SFB synthesized by using chip 2, the reaction mixture obtained from outlet M was purified by solid phase extraction, as done for the above one-pot synthesis, and applied for radiolabeling with bovine serum albumin (BSA) (Fig 11). 4-[¹⁸F]Fluorobenzoyl ([¹⁸F]FB)-labeled BSA was obtained in good conversion yields (76 ± 9% from [¹⁸F]SFB, *n* = 4), which indicated that the quality of [¹⁸F]SFB synthesized using chip 2 was equal to that synthesized using conventional methods.

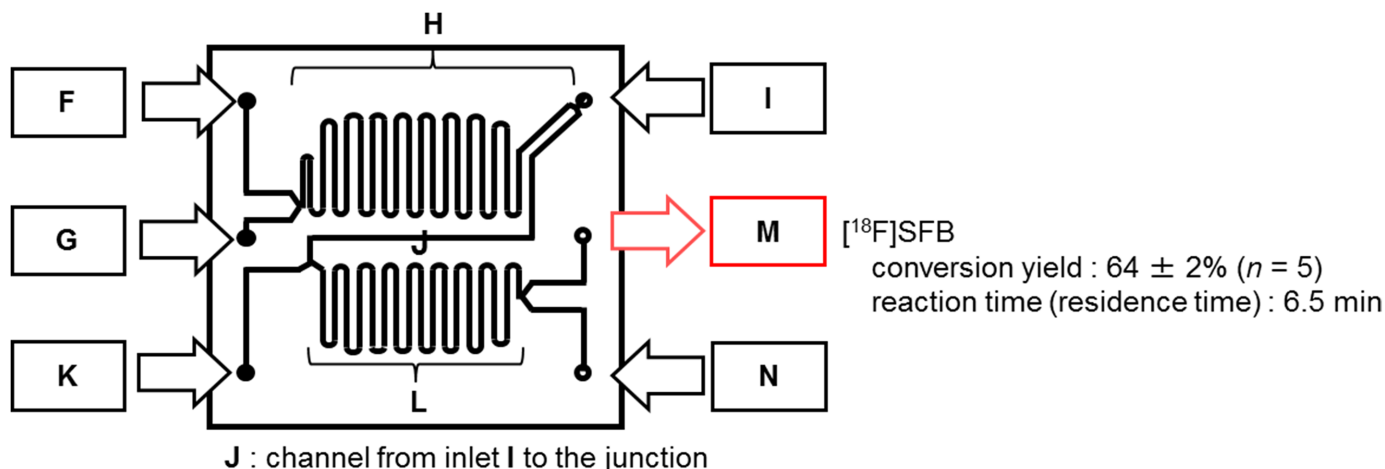

Inlet	Reagents	Flow rate (μL/min)
F	[¹⁸ F]KF, Kryptofix 2.2.2 in DMSO	0.56
G	1 in DMSO	
I	0.04 M TPAH in DMSO (containing 4% water)	1.12
K	TSTU	2.24
N	DMSO/water (90/10)	

Fig 10. (a) Microfluidic chip for three-step reaction (chip 2) and (b) conditions for continuous-flow synthesis of [¹⁸F]SFB.

doi:10.1371/journal.pone.0159303.g010

Conclusions

We have demonstrated the feasibility of a new continuous-flow synthetic method for a multi-step procedure using a single microfluidic chip. Continuous-flow synthesis of [¹⁸F]SFB using chip 2 gave a higher conversion yield and a shorter reaction time than that using a batch reactor. In our microreactor, the reaction efficiency was improved by enabling the reaction to be completed rapidly. After the preparation of reagents injected to the microreactor, the synthesis was automatically performed by supplying the reagents continuously and reproducibly achieved. In addition, this microreactor can be operated easily and does not require advanced skills. Continuous-flow synthetic procedure using this microreactor should therefore be readily

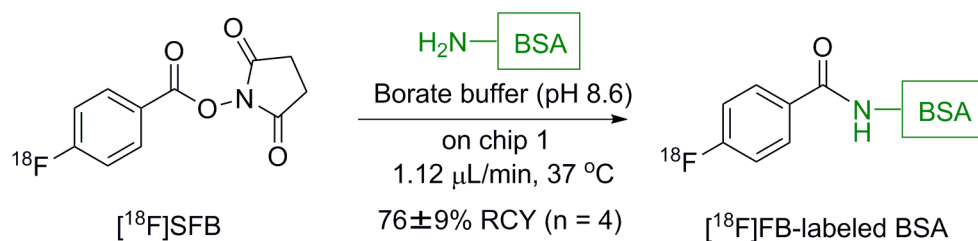

Fig 11. Radiolabeling of BSA with [¹⁸F]SFB synthesized using chip 2 (data are the mean ± S.D., n = 4).

doi:10.1371/journal.pone.0159303.g011

adaptable to the automated production of [^{18}F]SFB. The re-design of the microfluidic chip to enable the treatment of large quantities of reaction solution in a short time is required for commercial application.

Supporting Information

S1 Fig. Temperature distribution on chip 1. (a) Microreactor device, (b) chip design and temperature measurement points, (c) point temperatures recorded using digital thermometer, and (d) thermographic images. The results demonstrated that chip 1 was uniformly heated together within $\pm 5^\circ\text{C}$ of the set temperature.

(TIF)

S2 Fig. Microscopy images of channels (solvent: DMSO, temperature: 120°C , retention time: 10 s). It was observed that the solution has been thoroughly mixed at a point III where is after 5 s from the intersection of the two solutions (point I).

(TIF)

S3 Fig. Temperature distribution on chip 2. (a) Microreactor device, (b) chip design and temperature measurement points, (c) point temperatures recorded using digital thermometer, and (d) thermographic images. The results demonstrated that chip 1 was uniformly heated together within $\pm 5^\circ\text{C}$ of the set temperature.

(TIF)

Author Contributions

Conceived and designed the experiments: H. Kimura RI H. Saji. Performed the experiments: H. Kimura KT KA MO H. Saji. Analyzed the data: H. Kawashima YK. Contributed reagents/materials/analysis tools: H. Saiki RI. Wrote the paper: H. Kimura KT KA MO H. Kawashima H. Saji. Flow simulation: HN EO.

References

1. Phelps ME. Positron emission tomography provides molecular imaging of biological processes. *Proc Natl Acad Sci USA*. 2000; 97: 9226–9233. PMID: [10922074](#)
2. Fletcher PDI, Haswell SJ, Pombo-Villar E, Warrington BH, Watts P, Wong SYF, et al. Micro reactor: principles and applications in organic synthesis. *Tetrahedron* 2002; 58: 4735–4757.
3. Audrain H. Positron Emission Tomography (PET) and Microfluidic Devices: A Breakthrough on the Microscale? *Angew Chem Int Ed*. 2007; 46: 1772–1775.
4. Elizarov M. Microreactors for radiopharmaceutical synthesis. *Lab Chip*. 2009; 9: 1326–1333. doi: [10.1039/b820299k](#) PMID: [19417895](#)
5. Miller PW. Radiolabelling with short-lived PET (positron emission tomography) isotopes using microfluidic reactors. *J Chem Technol Biotechnol*. 2009; 84: 309–315.
6. Lin WY, Wang Y, Wang S, Tseng HR. Integrated microfluidic reactors. *Nano Today* 2009; 4: 470–481. PMID: [20209065](#)
7. Watts P, Pascali G, Salvadori PA. Positron Emission Tomography Radiosynthesis in Microreactors. *J Flow Chem*. 2012; 2: 37–42.
8. Regenfuss P, Clegg RM, Fulwyler MJ, Barrantes FJ, Jovin TM. Mixing liquids in microseconds. *Rev Sci Instrum*. 1985; 56: 283–290.
9. Mitchell P. Microfluidics—downsizing large-scale biology. *Nat Biotechnol*. 1985; 19: 717–721.
10. Ramsey JM. The burgeoning power of the shrinking laboratory. *Nat Biotechnol*. 1999; 17: 1061–1062. PMID: [10545906](#)
11. Lu SY, Watts P, Chin FT, Hong J, Musachio JL, Briard E, et al. Syntheses of ^{11}C - and ^{18}F -labeled carboxylic esters within a hydrodynamically-driven micro-reactor. *Lab Chip*. 2004; 4: 523–525. PMID: [15570360](#)

12. Miller PW, Long NJ, deMello AJ, Vilar R, Audrain H, Bender D, et al. Rapid Multiphase Carbonylation Reactions by Using a Microtube Reactor: Applications in Positron Emission Tomography ^{11}C -Radiolabeling. *Angew Chem Int Ed*. 2007; 46: 2875–2878.
13. Chun JH, Lu S, Lee YS, Pike VW. Fast and High-Yield Microreactor Syntheses of ortho-Substituted ^{18}F Fluoroarenes from Reactions of ^{18}F Fluoride Ion with Diaryliodonium Salts. *J Org Chem*. 2010; 75: 3332–3338. doi: [10.1021/jo100361d](https://doi.org/10.1021/jo100361d) PMID: [20361793](https://pubmed.ncbi.nlm.nih.gov/20361793/)
14. Miller PW, Audrain H, Bender D, deMello AJ, Gee AD, Long NJ, et al. Rapid Carbon-11 Radiolabelling for PET Using Microfluidics. *Chem Eur J*. 2011; 17: 460–463. doi: [10.1002/chem.201002644](https://doi.org/10.1002/chem.201002644) PMID: [21207561](https://pubmed.ncbi.nlm.nih.gov/21207561/)
15. Lee C, Sui G, Elizarov A, Shu CJ, Shin YS, Dooley AN, et al. Multistep Synthesis of a Radiolabeled Imaging Probe Using Integrated Microfluidics. *Science* 2005; 310: 1793–1796. PMID: [16357255](https://pubmed.ncbi.nlm.nih.gov/16357255/)
16. Elizarov M, van Dam RM, Shin YS, Kolb HC, Padgett HC, Stout D, et al. Design and Optimization of Coin-Shaped Microreactor Chips for PET Radiopharmaceutical Synthesis. *J Nucl Med*. 2010; 51: 282–287. doi: [10.2967/jnumed.109.065946](https://doi.org/10.2967/jnumed.109.065946) PMID: [20124050](https://pubmed.ncbi.nlm.nih.gov/20124050/)
17. Haroun S, Sanei Z, Jivan S, Schaffer P, Ruth TJ, Li PCH. Continuous-flow synthesis of ^{11}C raclopride, a positron emission tomography radiotracer, on a microfluidic chip. *Can J Chem*. 2013; 91: 326–332.
18. Gillies JM, Prenant C, Chimon GN, Smethurst GJ, Perrie W, Hamblett I, et al. Microfluidic reactor for the radiosynthesis of PET radiotracers. *Appl Radiat Isot*. 2006; 64: 325–332. PMID: [16290944](https://pubmed.ncbi.nlm.nih.gov/16290944/)
19. Gillies JM, Prenant C, Chimon GN, Smethurst GJ, Dekker BA, Zweit J. Microfluidic technology for PET radiochemistry. *Appl Radiat Isot*. 2006; 64: 333–336. PMID: [16290947](https://pubmed.ncbi.nlm.nih.gov/16290947/)
20. Bouvet VR, Wuest M, Wiebe LI, Wuest F. Synthesis of hypoxia imaging agent 1-(5-deoxy-5-fluoro- α -D-arabinofuranosyl)-2-nitroimidazole using microfluidic technology. *Nucl Med Biol*. 2011; 38: 235–245. doi: [10.1016/j.nucmedbio.2010.09.002](https://doi.org/10.1016/j.nucmedbio.2010.09.002) PMID: [21315279](https://pubmed.ncbi.nlm.nih.gov/21315279/)
21. Kealey S, Plisson C, Collier TL, Long NJ, Husbands SM, Martarello L, et al. Microfluidic reactions using ^{11}C carbon monoxide solutions for the synthesis of a positron emission tomography radiotracer. *Org Biomol Chem*. 2011; 9: 3313–3319. doi: [10.1039/c0ob00631a](https://doi.org/10.1039/c0ob00631a) PMID: [21437342](https://pubmed.ncbi.nlm.nih.gov/21437342/)
22. Bouvet V, Wuest M, Tam PH, Wang M, Wuest F. Microfluidic technology: An economical and versatile approach for the synthesis of *O*-(2- ^{18}F fluoroethyl)-L-tyrosine (^{18}F FET). *Bioorg Med Chem Lett*. 2012; 22: 2291–2295. doi: [10.1016/j.bmcl.2012.01.083](https://doi.org/10.1016/j.bmcl.2012.01.083) PMID: [22342141](https://pubmed.ncbi.nlm.nih.gov/22342141/)
23. Wong R, Iwata R, Saiki H, Furumoto S, Ishikawa Y, Ozeki E. Reactivity of electrochemically concentrated anhydrous ^{18}F fluoride for microfluidic radiosynthesis of ^{18}F -labeled compounds. *Appl Radiat Isot*. 2012; 70: 193–199. doi: [10.1016/j.apradiso.2011.09.022](https://doi.org/10.1016/j.apradiso.2011.09.022) PMID: [22001413](https://pubmed.ncbi.nlm.nih.gov/22001413/)
24. Dahl K, Schou M, Halldin C. Radiofluorination and reductive amination using a microfluidic device. *J Labelled Compd Radiopharm*. 2012; 55: 455–459.
25. Ungersboeck J, Richter S, Collier L, Mitterhauser M, Karanikas G, Lanzemberger R, et al. Radiolabeling of ^{18}F altanserin—a microfluidic approach. *Nucl Med Biol*. 2012; 39: 1087–1092. doi: [10.1016/j.nucmedbio.2012.04.004](https://doi.org/10.1016/j.nucmedbio.2012.04.004) PMID: [22633218](https://pubmed.ncbi.nlm.nih.gov/22633218/)
26. Arima V, Pascali G, Lade O, Kretschmer HR, Bernsdorf I, Hammond V, et al. Radiochemistry on chip: towards dose-on-demand synthesis of PET radiopharmaceuticals. *Lab Chip*. 2013; 13: 2328–2336. doi: [10.1039/c3lc00055a](https://doi.org/10.1039/c3lc00055a) PMID: [23639996](https://pubmed.ncbi.nlm.nih.gov/23639996/)
27. Steel J, O'Brien AT, Luthra SK, Brady F. Automated PET radiosyntheses using microfluidic devices. *J Labelled Compd Radiopharm*. 2007; 50: 308–311.
28. Liang SH, Yokell DL, Jackson RN, Rice PA, Callahan R, Johnson KA, et al. Microfluidic continuous-flow radiosynthesis of ^{18}F FPEB suitable for human PET imaging. *MedChemCommun*. 2014; 5:432–435.
29. Vaidyanathan G, Zalutsky MR. Labeling Proteins with Fluorine-18 Using *N*-Succinimidyl 4- ^{18}F Fluorobenzoate. *Nucl Med Biol*. 1992; 19: 275–281.
30. Wester HJ, Hamacher K, Stöcklin G. A comparative Study of N.C.A Fluorine-18 Labeling of Proteins via Acylation and Photochemical Conjugation. *Nucl Med Biol*. 1996; 23: 365–372. PMID: [8782249](https://pubmed.ncbi.nlm.nih.gov/8782249/)
31. Wüst F, Hultsch C, Bergmann R, Johannsen B, Henle T. Radiolabelling of isopeptide N^{ϵ} -(γ -glutamyl)-L-lysine by conjugation with *N*-succinimidyl-4- ^{18}F fluorobenzoate. *Appl Radiat Isot*. 2003; 59: 43–48. PMID: [12878121](https://pubmed.ncbi.nlm.nih.gov/12878121/)
32. Guenther KJ, Yoganathan S, Garofalo R, Kawabata T, Strack T, Labiris R, et al. Synthesis and in Vitro Evaluation of ^{18}F - and ^{19}F -Labeled Insulin: A New Radiotracer for PET-based Molecular Imaging Studies. *J Med Chem*. 2006; 49: 1466–1474. PMID: [16480283](https://pubmed.ncbi.nlm.nih.gov/16480283/)
33. Vaidyanathan G, Zalutsky MR. Synthesis of *N*-succinimidyl 4- ^{18}F fluorobenzoate, an agent for labeling proteins and peptides with ^{18}F . *Nat Protoc*. 2006; 1: 1655–1661. PMID: [17487148](https://pubmed.ncbi.nlm.nih.gov/17487148/)

34. Tang G, Zeng W, Yu M, Kabalka G. Facile synthesis of *N*-succinimidyl 4-¹⁸F-fluorobenzoate (¹⁸F-SFB) for protein labeling. *J Labelled Compd Radiopharm*. 2008; 51: 68–71.
35. Mäding P, Fuchtnr F, Wüst F. Module-assisted synthesis of the bifunctional labelling agent *N*-succinimidyl 4-¹⁸F-fluorobenzoate (¹⁸F-SFB). *Appl Radiat Isot*. 2005; 63: 329–332. PMID: [15949940](#)
36. Marik J, Sutcliffe JL. Fully automated preparation of n.c.a. 4-¹⁸F-fluorobenzoic acid and *N*-succinimidyl 4-¹⁸F-fluorobenzoate using a Siemens/CTI chemistry process control unit (CPCU). *Appl Radiat Isot*. 2007; 65: 199–203. PMID: [16935516](#)
37. Kimura H, Yagi Y, Ohneda N, Odajima H, Ono M, Saji H. Development of a resonant-type microwave reactor and its application to the synthesis of positron emission tomography radiopharmaceuticals. *J Labelled Compd Radiopharm*. 2014; 57: 680–686.
38. Bannwarth W, Knorr R. Formation of carboxamides with *N,N,N',N'*-tetramethyl(succinimido) uranium tetrafluoroborate in aqueous / organic solvent systems. *Tetrahedron Lett*. 1991; 32: 1157–1160.