



Calhoun: The NPS Institutional Archive

Theses and Dissertations

Thesis and Dissertation Collection

2016-12

Norwegian Armed Forces Personnel Recovery Network

Christiansen, Morten N.

Monterey, California: Naval Postgraduate School

<http://hdl.handle.net/10945/51672>



Calhoun is a project of the Dudley Knox Library at NPS, furthering the precepts and goals of open government and government transparency. All information contained herein has been approved for release by the NPS Public Affairs Officer.

Dudley Knox Library / Naval Postgraduate School
411 Dyer Road / 1 University Circle
Monterey, California USA 93943

<http://www.nps.edu/library>



**NAVAL
POSTGRADUATE
SCHOOL**

MONTEREY, CALIFORNIA

CAPSTONE

**NORWEGIAN ARMED FORCES PERSONNEL
RECOVERY NETWORK**

by

Morten N. Christiansen

December 2016

Thesis Advisor:
Second Reader:

Nancy Roberts
George Lober

Approved for public release. Distribution is unlimited.

THIS PAGE INTENTIONALLY LEFT BLANK

REPORT DOCUMENTATION PAGE			Form Approved OMB No. 0704-0188	
Public reporting burden for this collection of information is estimated to average 1 hour per response, including the time for reviewing instruction, searching existing data sources, gathering and maintaining the data needed, and completing and reviewing the collection of information. Send comments regarding this burden estimate or any other aspect of this collection of information, including suggestions for reducing this burden, to Washington headquarters Services, Directorate for Information Operations and Reports, 1215 Jefferson Davis Highway, Suite 1204, Arlington, VA 22202-4302, and to the Office of Management and Budget, Paperwork Reduction Project (0704-0188) Washington, DC 20503.				
1. AGENCY USE ONLY (Leave blank)	2. REPORT DATE December 2016	3. REPORT TYPE AND DATES COVERED Capstone project report		
4. TITLE AND SUBTITLE NORWEGIAN ARMED FORCES PERSONNEL RECOVERY NETWORK			5. FUNDING NUMBERS	
6. AUTHOR(S) Morten N. Christiansen				
7. PERFORMING ORGANIZATION NAME(S) AND ADDRESS(ES) Naval Postgraduate School Monterey, CA 93943-5000			8. PERFORMING ORGANIZATION REPORT NUMBER	
9. SPONSORING /MONITORING AGENCY NAME(S) AND ADDRESS(ES) N/A			10. SPONSORING / MONITORING AGENCY REPORT NUMBER	
11. SUPPLEMENTARY NOTES The views expressed in this thesis are those of the author and do not reflect the official policy or position of the Department of Defense or the U.S. Government. IRB Protocol number ____N/A____.				
12a. DISTRIBUTION / AVAILABILITY STATEMENT Approved for public release. Distribution is unlimited.			12b. DISTRIBUTION CODE	
13. ABSTRACT (maximum 200 words)				
<p>In 2014, the Royal Norwegian Air Force (RNoAF) became the Executive Agent Office of Primary Responsibility (EA OPR) for Personnel Recovery (PR) for the Norwegian Armed Forces. This capstone project is sponsored by the commander RNoAF PR and SERE School to support the development of a whole-of-department approach to PR by answering this question:</p> <p style="padding-left: 40px;">How can we design a Personnel Recovery (PR) system for the Norwegian Armed Forces that enables Norwegian commanders and staffs, forces and isolated personnel to collaborate and operate in a combined joint PR mission environment?</p> <p>This capstone project explores PR for the Norwegian Armed Forces through an inquiry of design and design thinking. As an initiation of the design process, the capstone begins the discovery phase with an examination of archival records centered on PR from WWII to the present and in-depth discussions with national and international PR subject-matter experts. This capstone describes the results from the design thinking process, its prototypes, and recommendations to the RNoAF.</p> <p>In brief, the capstone project recommends that the Norwegian Armed Forces, with the RNoAF as the EA OPR for PR, develop a network organization that coordinates the main actors in the PR system into well-functioning communities of practice.</p>				
14. SUBJECT TERMS personnel recovery, design, design thinking, network, network design, network governance, network administrative organization, lead organization, shared governance, community of practice, PR			15. NUMBER OF PAGES 229	
			16. PRICE CODE	
17. SECURITY CLASSIFICATION OF REPORT Unclassified	18. SECURITY CLASSIFICATION OF THIS PAGE Unclassified	19. SECURITY CLASSIFICATION OF ABSTRACT Unclassified	20. LIMITATION OF ABSTRACT UU	

THIS PAGE INTENTIONALLY LEFT BLANK

Approved for public release. Distribution is unlimited.

NORWEGIAN ARMED FORCES PERSONNEL RECOVERY NETWORK

Morten N. Christiansen
Major, Royal Norwegian Air Force
BS, Royal Norwegian Air Force Academy, 2006

Submitted in partial fulfillment of the
requirements for the degree of

MASTER OF SCIENCE IN DEFENSE ANALYSIS

from the

**NAVAL POSTGRADUATE SCHOOL
December 2016**

Approved by: Nancy Roberts
Thesis Advisor

George Lober
Second Reader

John Arquilla
Chair, Department of Defense Analysis

THIS PAGE INTENTIONALLY LEFT BLANK

ABSTRACT

In 2014, the Royal Norwegian Air Force (RNoAF) became the Executive Agent Office of Primary Responsibility (EA OPR) for Personnel Recovery (PR) for the Norwegian Armed Forces. This capstone project is sponsored by the commander RNoAF PR and SERE School to support the development of a whole-of-department approach to PR by answering this question:

How can we design a Personnel Recovery (PR) system for the Norwegian Armed Forces that enables Norwegian commanders and staffs, forces and isolated personnel to collaborate and operate in a combined joint PR mission environment?

This capstone project explores PR for the Norwegian Armed Forces through an inquiry of design and design thinking. As an initiation of the design process, the capstone begins the discovery phase with an examination of archival records centered on PR from WWII to the present and in-depth discussions with national and international PR subject-matter experts. This capstone describes the results from the design thinking process, its prototypes, and recommendations to the RNoAF.

In brief, the capstone project recommends that the Norwegian Armed Forces, with the RNoAF as the EA OPR for PR, develop a network organization that coordinates the main actors in the PR system into well-functioning communities of practice.

THIS PAGE INTENTIONALLY LEFT BLANK

TABLE OF CONTENTS

I.	INTRODUCTION.....	1
A.	PERSONNEL RECOVERY FOR VALUE OR VALOR	1
B.	WHY THE NORWEGIAN PR SYSTEM?	5
C.	CAPSTONE APPROACH	6
D.	CAPSTONE PURPOSE AND STRUCTURE.....	7
II.	DESIGN AND DESIGN THINKING	9
A.	INTRODUCTION.....	9
B.	DESIGN	9
C.	DESIGN THINKING	14
1.	The Design Challenge	16
2.	Discovery Phase.....	16
3.	Problem Definition Phase.....	17
4.	Ideation Phase	17
5.	Prototyping Phase	17
6.	Testing Phase.....	18
D.	DESIGN THINKING AND PROBLEM-SOLVING.....	18
E.	THE NORWEGIAN PR CAPSTONE PROJECT	21
1.	Key Personnel.....	21
2.	Design Challenge.....	24
3.	Design Constraints	25
4.	The Norwegian Armed Forces Personal Recovery Network Design Thinking Process	25
III.	DISCOVERY.....	27
A.	INTRODUCTION.....	27
1.	Overview of Sources	27
B.	ARCHIVAL RECORDS	29
1.	Doctrinal Overview of PR: United States and NATO	29
2.	The History of Personnel Recovery	45
3.	The Strategic Impact of Personnel Recovery	53
4.	The Evolution of Personnel Recovery Doctrine	60
5.	The Evolution of Norwegian Personnel Recovery	62
C.	DESCRIBING THE NORWEGIAN PR SYSTEM AS A NETWORK	65
D.	PERSONNEL RECOVERY DISCUSSIONS.....	74
1.	Policy and Doctrine.....	74

2.	Education and Training	75
3.	Equipment	75
4.	Isolated Personnel	75
5.	Forces	76
6.	Commanders and Staffs	76
E.	PARTICIPANT OBSERVATIONS	77
F.	GENERAL THEMES.....	79
1.	Policy and Doctrine.....	80
2.	Organization.....	80
3.	Education and Training	81
4.	Equipment	81
5.	Personnel.....	81
6.	Political.....	82
7.	Economics and Ethics.....	82
IV.	PROBLEM DEFINITION	83
A.	INTRODUCTION.....	83
B.	PROBLEM DEFINITION	83
C.	THE PR NETWORK AS OF 2014.....	84
D.	THE REDESIGN OF THE NORWEGIAN PR SOCIAL NETWORK	86
1.	Doctrine.....	87
2.	Governance.....	88
3.	Network Processes	88
4.	Structure	88
E.	PROBLEM REFRAMED	93
V.	IDEATION	95
A.	INTRODUCTION.....	95
1.	PR Network Governance and Structure.....	95
2.	PR Network Processes	96
3.	PR Doctrine	97
VI.	PROTOTYPE AND TESTING	99
A.	INTRODUCTION.....	99
B.	PROTOTYPE DEVELOPMENT	99
1.	The NPRN Multilevel Governance Model.....	99
2.	The NPRN Community of Practice.....	99
C.	THE NPRN MULTILEVEL GOVERNANCE MODEL.....	100

1.	Network Administrative Organization (Interorganizational).....	101
2.	Lead Organization (Intraorganizational)	104
3.	Self-Governance (Tactical Unit Level).....	105
4.	NPRN Governance and the Network Design Continuum.....	105
5.	Management <i>of</i> and <i>in</i> Networks.....	108
D.	THE NPRN COMMUNITY OF PRACTICE	110
1.	NPRN Community of Practice Real Place.....	111
2.	NPRN Community of Practice Virtual Space	112
3.	NPRN Community of Practice Pace.....	113
E.	PROTOTYPE TESTING	118
VII.	CONCLUSION	121
A.	PERSONNEL RECOVERY FOR VALUE OR VALOR	121
1.	Bigger Ideas	122
B.	CAPSTONE SOLUTION.....	123
C.	DESIGN PROCESS AND CAPSTONE APPLICABILITY	124
1.	Design Process	124
2.	Capstone Applicability	125
3.	Areas for Future Studies	125
APPENDIX A.	PR BIBLIOGRAPHY.....	127
A.	INTRODUCTION.....	127
B.	RELEVANT ABSTRACT THEORY	127
C.	CASE STUDIES AND PR ACTOR–SPECIFIC LITERATURE	128
D.	CURRENT MILITARY POLICY AND DOCTRINE	148
E.	ACADEMIC THESES.....	152
F.	UNPUBLISHED RESEARCH PAPERS.....	152
G.	JOURNAL ARTICLES.....	153

APPENDIX B. DESIGN AND DESIGN THINKING BIBLIOGRAPHY	155
APPENDIX C. NETWORK DESIGN THEORY BIBLIOGRAPHY	159
APPENDIX D. COMMUNITIES OF PRACTICE	161
APPENDIX E. NPRN CORE STRUCTURE.....	163
APPENDIX F. PR DOCTRINAL EVOLUTION	185
APPENDIX G. ROBERTS NETWORK DESIGN FRAMEWORK.....	193
LIST OF REFERENCES.....	195
INITIAL DISTRIBUTION LIST	207

LIST OF FIGURES

Figure 1.	Andree de Jongh	1
Figure 2.	Thomas Rolland Norris.....	2
Figure 3.	Gary Ivan Gordon	3
Figure 4.	Aleksander Hesseberg Vikebø.....	4
Figure 5.	Assessment, Change, and Design	13
Figure 6.	Stanford d.school Human-Centered Design	15
Figure 7.	The Design Thinking Process I.....	16
Figure 8.	The Design Thinking Process II	19
Figure 9.	The Design Thinking Process III	20
Figure 10.	Seeing the Whole of Systems	22
Figure 11.	PR System Model	32
Figure 12.	PR System Preparation Function	33
Figure 13.	PR System Planning Function	35
Figure 14.	PR Options, Capabilities, and Methods	36
Figure 15.	PR System Execution Function	38
Figure 16.	PR System Report Task	39
Figure 17.	PR System Locate Task	40
Figure 18.	PR System Support Task	41
Figure 19.	PR System Recover Task.....	42
Figure 20.	PR System Reintegrate Task.....	43
Figure 21.	PR System Adaptation Function.....	45
Figure 22.	The Strategic Impact of PR.....	54
Figure 23.	PR Propaganda.....	59

Figure 24.	PR Doctrine Hierarchy.....	61
Figure 25.	Timeline of the Evolution of PR Doctrine.....	61
Figure 26.	Norwegian PR System Links as of June 2015.....	66
Figure 27.	Roberts’s Network Design Framework.....	67
Figure 28.	Network Purposes.....	72
Figure 29.	PR System Model.....	83
Figure 30.	Norwegian PR Network at Capstone Initiation in 2014.....	84
Figure 31.	Roberts’s Network Design Framework.....	86
Figure 32.	RNoAF EA of PR and SERE in a Network Governance Perspective.....	90
Figure 33.	Modes of Network Governance.....	91
Figure 34.	Network Governance Structure Options.....	93
Figure 35.	NPRN Network Governance Prototype.....	100
Figure 36.	NPRN and the NAO at the Interorganizational Level.....	102
Figure 37.	NPRN and the NAO and the External PR Network.....	103
Figure 38.	NPRN Example Service OPRs.....	104
Figure 39.	Air Force and Army Unit-Level Self-Governance.....	105
Figure 40.	NPRN Governance from Joint to Individual and Strategic to Tactical ...	106
Figure 41.	Management of and in Networks.....	109
Figure 42.	Physical PR Knowledge Space.....	112
Figure 43.	NPRN CoP PR Event “Wheel”.....	114
Figure 44.	NPRN Example of PR and SERE PACE and CoP.....	115
Figure 45.	Communities of Practice: Creating Ties, Trust and Social Capital I.....	117
Figure 46.	Communities of Practice: Creating Ties, Trust and Social Capital II.....	118
Figure 47.	Notional Personnel Recovery Organization Structure.....	164
Figure 48.	Overview of Norwegian Armed Forces Operational Structure.....	165

Figure 49.	RNoAF PR C2 Architecture	166
Figure 50.	RNoAF PR C2 Architecture Clean	167
Figure 51.	RNoAF PR C2 Architecture with Education and Training	168
Figure 52.	RNoAF PR Forces	169
Figure 53.	RNoAF PR Forces with Education and Training	169
Figure 54.	RNoAF Isolated Personnel with Education and Training.....	170
Figure 55.	RNoAF Aggregate of the NPRN	171
Figure 56.	PR System Levels	171
Figure 57.	Norwegian Army PR C2 Architecture.....	172
Figure 58.	Norwegian Army PR C2 Architecture Clean.....	172
Figure 59.	Norwegian Army PR C2 Architecture with Education and Training.....	173
Figure 60.	Norwegian Army PR Forces.....	173
Figure 61.	Norwegian Army PR Forces with Education and Training	174
Figure 62.	Norwegian Army Isolated Personnel with Education and Training.....	174
Figure 63.	Norwegian Army Aggregate of the NPRN.....	175
Figure 64.	Norwegian Navy PR C2 Architecture.....	175
Figure 65.	Norwegian Navy PR C2 Architecture Clean	176
Figure 66.	Norwegian Navy PR C2 Architecture with Education and Training.....	176
Figure 67.	Norwegian Navy PR Forces.....	177
Figure 68.	Norwegian Navy PR Forces with Education and Training.....	177
Figure 69.	Norwegian Navy Isolated Personnel and Education and Training	178
Figure 70.	Navy Aggregate of the NPRN	178
Figure 71.	NORSOF PR C2 Architecture	179
Figure 72.	NORSOF PR C2 Architecture Clean.....	179
Figure 73.	NORSOF PR C2 Architecture with Education and Training	180

Figure 74.	NORSOF PR Forces	180
Figure 75.	NORSOF PR Forces with Education and Training	181
Figure 76.	NORSOF Isolated Personnel with Education and Training	181
Figure 77.	NORSOF Aggregate of the NPRN	182
Figure 78.	NPRN Aggregate	182

LIST OF ACRONYMS AND ABBREVIATIONS

AARG	Aerospace Rescue and Recovery Group
ARRS	Aerospace Rescue and Recovery Service
ADTIC	Arctic, Desert, Tropic Information Center
AFDD	Air Force Doctrine Document
AFI	Air Force Instruction
AFTTP	Air Force Tactics, Techniques, and Procedures
AJP	Allied Joint Publication
ATP	Allied Tactical Publication
BI-SC	Bi-Strategic Command
CaC	Conduct After Capture
CAR	Care After Recovery
CHOD	Chief of Defense
CIA	Central Intelligence Agency
CJCS	Chairman of the Joint Chiefs of Staff
CJCSI	Chairman, Joint Chiefs of Staff Instruction
CoC	Code of Conduct
CONOP	Concept of Operations
CoP	Communities of Practice
CR	Combat Recovery
CRU	Crisis Response Unit
CSAR	Combat Search and Rescue
CW3	Chief Warrant Officer 3
DOD	Department of Defense
DODD	Department of Defense Directive
DODI	Department of Defense Instruction
DOJ	Department of Justice
DOS	Department of State
DPMO	Defense Prisoner of War/Missing Personnel Office
DSAR	Deployed Search and Rescue
D.S.O.	Distinguished Service Order
DT	Design Thinking
EAG	European Air Group
EA	Executive Agent
EPA	Evasion Plan of Action
E&E	Escape and Evasion
FAC	Forward Air Controller
FM	Field Manual (Army)

FLOT	Forward Line of Own Troops
FOB	Forward Operating Base
FSK	Forsvarets Spesialkommando [Norwegian Army Special Operations Command]
FVS	Forsvarets Vinterskole [Norwegian School of Winter Warfare]
GC	George Cross
GSG-9	Grenzschutzgruppe 9 [Border Protection Group 9]
HR	Hostage Rescue
HRC	High-Risk-of-Capture
IP	Isolated Personnel
ICRC	International Committee of the Red Cross
ISIL	Islamic State of Iraq and the Levant
ISOPREP	Isolated Personnel Report
JAPCC	Joint Air Power Competence Centre
JOG	Joint Operational Guidelines
JFC	Joint Force Commander
JP	Joint Publication
JPR	Joint Personnel Recovery
JPRA	Joint Personnel Recovery Agency
JPRC	Joint Personnel Recovery Center
JSOC	Joint Special Operations Command
JSSA	Joint Services Survival, Evasion, Resistance, and Escape Agency
JTTP	Joint Tactics, Techniques, and Procedures
JWP	Joint Warfare Publication
LRDG	Long Range Desert Group
MI9	Military Intelligence 9
MIS-X	Military Intelligence Service-X
MJVTS	Marinens Jegervåpen Trenings Senter [Naval Ranger and EOD Training Center]
MOH	Medal of Honor
NAO	Network Administrative Organization
NATO	North Atlantic Treaty Organization
NORASOC	Norwegian Army Special Operations Command [FSK]
NORNAVSOC	Norwegian Naval Special Operations Command [MJK]
NORSOCOM	Norwegian Special Operations Command
NORSOF	Norwegian Special Operations Forces
NPS	Naval Postgraduate School
NPRN	Norwegian Armed Forces Personnel Recovery Network

NSPD	National Security Presidential Directive
OAF	Operation Allied Force
OEF	Operation Enduring Freedom
OGA	Other Government Agency
ONA	Operational Network Analysis
OPR	Office of Primary Responsibility
ORH	Operation Restore Hope
OSS	Office of Strategic Services
OUP	Operation Unified Protector
POV	Point of View
POW	Prisoner of War
PR	Personnel Recovery
PRCC	Personnel Recovery Coordination Cell
PRETC	Personnel Recovery Education and Training Center
PRRC	Personnel Recovery Response Cell
RESCAP	Rescue Combat Air patrol
RNoAF	Royal Norwegian Air Force
SA	Situational Awareness
SACEUR	Supreme Allied Commander, Europe (NATO)
SACT	Supreme Allied Commander, Transformation
SAR	Search and Rescue
SAS	Special Air Service
SB	Stay Behind
SD	Study Draft
SEAL	Sea, Air, and Land
SecDef	Secretary of Defense
SERE	Survival, Evasion, Resistance, and Escape
SFG	Special Forces Group
SHAPE	Supreme Headquarters Allied Powers, Europe
SNA	Social Network Analysis
SOE	Special Operations Executive
SOF	Special Operations Forces
STANAG	Standardization Agreement (NATO)
TRAP	Tactical Recovery of Aircraft and Personnel
TTP	Tactics, Techniques, and Procedures
UAR	Unconventional Assisted Recovery
UK	United Kingdom
UN	United Nations
USG	United States Government

USA	United States Army
USAF	United States Air Force
USMC	United States Marine Corps
USN	United States Navy
USSOCOM	United States Special Operations Command
WWII	World War II

ACKNOWLEDGMENTS

No matter what era, area, or circumstance, rescue has always been one of the great human interest stories. ... There is no saga quite as inspiring, as exhilarating, or as dramatic as that of man risking serious injury or death itself to help his fellow man in trouble. Rescue is a compelling, all-encompassing human instinct. In crisis people pull together as never before, often performing deeds far beyond their normal capacities when a life is in the balance. So it has always been and will always be. Such is the nature of man.

—L. B. Taylor, Jr.,
That Others May Live, 1967

This capstone project on designing a Norwegian Personnel Recovery Network has been a journey that has involved a large number of inspiring people. Crucial in pulling it all together, Dr. Nancy Roberts, my advisor, mentor, and champion of design and design thinking, has been of the utmost support and has provided a wealth of knowledge and experience to this project. I would also like to thank the faculty and staff of the Defense Analysis Department for a great program, diverse in nature, with student practitioners from many services and nations. For bringing special value to this capstone, I am very grateful for the teachings of John Arquilla, Kalev Sepp, George Lober, Siamak Naficy, Bradley J. Strawser, Harold Nelson, the Graduate Writing Center, and my editor, Rebecca Jackson.

This capstone would not be possible were it not for the support and sponsorship of Lt Col Christian “Spirit” Waldermo and the collaboration with his team at the RNoAF PR and SERE School. The development of Norwegian PR and SERE is largely due to the personal dedication and vested interest in the field by people like “Kid,” “Banzai,” “Darth,” “Bilbo,” and Frode Sjaastad from the RNoAF; “Blue” and his CaC instructors; the innovative “Dinosaur” Ingar Lund; NORSOFT training wings, as well as colleagues from the Army PR and SERE School. I would also like to thank Brigadier General (Ret.) Øyvind “Beachman” Strandman for the opportunity to attend NPS. In addition, I would like to give special recognition to the late Lene Gretland Graham for the support the

RNoAF and the PR community have always received. Finally, and most importantly, I thank my family, my wife, Tone, and my children, Håkon and Henrik, for their support and the joy they bring to my life.

I. INTRODUCTION

A. PERSONNEL RECOVERY FOR VALUE OR VALOR

Learning about Personnel Recovery (PR) has been a truly humbling experience. Incredible effort and self-sacrifice are needed to organize people and organizations to deal with the challenges of rescuing one's fellow brother-in-arms, isolated and on the run from the enemy, or suffering in captivity. From World War II to the present day, there are many instances of PR. The four preceding examples illustrate the courage and heroism of people who came to the aid of others (see Figures 1–4).

The first example of Personnel Recovery centers on the story of Andree de Jongh, who was a Belgian Resistance fighter during World War II. The following is an excerpt from *The Compleat Anglo in the Pays Basque* blog.



Figure 1. Andree de Jongh¹

Among the prisoners who emerged from the concentration camps of Germany at the liberation of France in 1945 was Andree de Jongh, the Belgian girl who had created an escape route for Allied servicemen from Brussels to Bilbao. Known as the Comet Line, it was the greatest escape route in the Resistance Movement and its three years of life saved over 800 Allied airmen and soldiers from captivity and returned them to England. “Little Cyclone” was a suitable pseudonym for the girl whose enterprise and energy inspired all who met her, for though she had many brave and forceful personalities to help her, she was always the leader. After her arrest, she suffered dreadfully in Ravensbruck and Mauthausen concentration camps, but her example inspired her successors in the line.

¹ Piperade, “72. Villa Voisin,” *The Compleat Anglo in the Pays Basque* (blog), July 21, 2010, <http://piperade-thecompleatanglo.blogspot.com/2010/07/72-villa-voisin.html>.

In 1945, she was freed, and in 1946, she came to England to receive the George Medal from the King.²

The second example of Personnel Recovery involves retired U.S. Navy SEAL Thomas Rolland Norris, who served in two tours of duty in Vietnam. The following excerpt illustrates Norris' fierce determination and perseverance.



Figure 2. Thomas Rolland Norris³

During the period 10 to 13 April 1972, Lt. Norris completed an unprecedented ground rescue of 2 downed pilots deep within heavily controlled enemy territory in Quang Tri Province. Lt. Norris, on the night of 10 April led a 5-man patrol through 2,000 meters of heavily controlled enemy territory, located 1 of the downed pilots at daybreak, and returned to the Forward Operating Base (FOB). On 11 April, after a devastating mortar and rocket attack on the small FOB, Lt. Norris led a 3-man team on 2 unsuccessful rescue attempts for the second pilot. On the afternoon of the 12th, a forward air controller located the pilot and notified Lt. Norris. Dressed in fishermen disguises and using a sampan, Lt. Norris and one Vietnamese traveled throughout that night and found the injured pilot at dawn. Covering the pilot with bamboo and vegetation, they began the return journey, successfully evading a North Vietnamese patrol. Approaching the FOB, they came under heavy machine gun fire. Lieutenant Norris called in an air strike which provided suppression fire and a smoke screen, allowing the rescue party to reach the FOB. By his outstanding display of decisive leadership, undaunted courage, and selfless

² Airey Neave, *Little Cyclone* (London: Hodder and Stoughton, 1954), front and back cover.

³ "Thomas R. Norris," NavySeals.com, accessed April 14, 2016, <http://navyseals.com/ns-overview/notable-seals/thomas-r-norris/>.

dedication in the face of extreme danger, Lt. Norris enhanced the finest traditions of the United States Naval Service.⁴

The story of Master Sergeant Gordon provides the third example of personnel recovery and a display of an altruistic act in an effort to rescue a fellow soldier.



Figure 3. Gary Ivan Gordon⁵

Master Sergeant Gordon, United States Army, distinguished himself by actions above and beyond the call of duty on October 3, 1993, while serving as Sniper Team Leader, United States Army Special Operations Command with Task Force Ranger in Mogadishu, Somalia. He and another sniper unhesitatingly volunteered to be inserted to protect the four critically wounded personnel ... then went back to the wreckage, recovering some of the crew's weapons and ammunition. Despite the fact, that he was critically low on ammunition, he provided some of it to the dazed pilot and then radioed for help. ... After his team member was fatally wounded and his own rifle ammunition exhausted, Master Sergeant Gordon returned to the wreckage, recovering a rifle with the last five rounds of ammunition and gave it to the pilot with the words, "good luck." Then, armed only with his pistol, Master Sergeant Gordon continued to fight until he was fatally wounded. His actions saved the pilot's life. Master Sergeant Gordon's extraordinary heroism and devotion to duty

⁴ For the Medal of Honor information, see "Congressional Medal of Honor Society," last modified April 14, 2016, <http://www.cmohs.org/recipient-detail/3374/norris-thomas-r.php>, and for a detailed account of the rescue, see Darrel D. Whitcomb, *The Rescue of Bat 21* (Annapolis, MD: Naval Institute Press, 1998).

⁵ "MSG Gary Ivan Gordon," Battle of Mogadishu, accessed April 14, 2016, <http://battleofmogadishu.com/in-memoriam/died-in-somalia/gary-gordon>.

were in keeping with the highest standards of military service and reflect great credit upon his unit and the United States Army.⁶

The last example of Personnel Recovery takes place in a Norwegian military context and brings PR closer to home, as these brave acts of the courageous Alexander Hesseberg Vikebø illustrate.



Figure 4. Aleksander Hesseberg Vikebø⁷

In 2014, the then 28-year-old Aleksander Hesseberg Vikebø, a member of the counter-terrorism unit Forsvarets Spesialkommando (FSK) received the Norwegian military's highest recognition of valor for his conduct and performance during a 2012 hostage rescue operation in Afghanistan while mentoring the Afghan Crisis Response Unit (CRU) during a spectacular attack in Kabul. As he was awarded the medal "*Krigskorset med sverd*" [War cross with sword] and also the second highest medal the "*St. Olavsmedaljen med ekegren*" [St. Olav's medal with oak leaf], he became the highest decorated soldier in the Norwegian Armed Forces since WWII. His medals were awarded for his display of professional skills, courage,

⁶ For the Medal of Honor citations, see "Congressional Medal of Honor Society"; for a detailed account of the event, see Mark Bowden, *Black Hawk Down: A Story of Modern War* (New York: Atlantic Monthly Press, 1999).

⁷ "I dag blir han Norges nye 'Kjakan'" [Today he becomes the new "jaw"], *Dagbladet* [Daily Magazine], May 8, 2014, <http://www.dagbladet.no/2014/05/08/nyheter/innenriks/forsvaret/afghanistan/krig/33184656/>.

and bravery during two missions where one was a nine-hour fight against the Taliban, which saved numerous hostages.⁸

These acts of personal courage, heroism, and self-sacrifice in coming to the rescue of fellow human beings were awarded with the highest military honors. They set the stage for this capstone project on Personnel Recovery in Norway: what PR has been in the past and how it could be redesigned to meet Norway's future needs.

B. WHY THE NORWEGIAN PR SYSTEM?

From WWII until the end of the Cold War, the focus of Norwegian PR was along the lines of the work started by the WWII Escape and Evasion (E&E) organization Military Intelligence 9 (MI9), and survival training of aircrew and Special Operations Forces (SOF). The survival training focused on surviving and evading in Norway among a friendly population. The Norwegian Intelligence service established, along with other North Atlantic Treaty Organization (NATO) nations, a secret stay-behind (SB) escape and evasion network designed to return aircrew shot down over NATO "overrun" territory. This secret stay-behind network was established as a continuation of the lessons learned from WWII.⁹

The end of the Cold War created a change in the dominant policy of defending the homeland and transitioned in the 1990s to engagement and participation in international coalition operations. The fighting in the Balkans in the 1990s and the decade-long involvement in Afghanistan have highlighted the need for proper Survival, Evasion, Resistance and Escape (SERE) training and the education of SERE instructors according to NATO standards. Initially, most nations relied on the United States military for all Combat Search and Rescue (CSAR) efforts, but early in 2000, a focus emerged on the role of PR-capable forces and their support for PR operations. In the 1990s, there was a shift from homeland operations to international operations, which included expanded

⁸ For a public reference to the event, see Sveinung Berg Bentzrød, "I dag ble Alexander (28) Norges høyest dekorerte etter andre verdenskrig" [Today Alexander (28) became the highest decorated soldier since WWII], *Aftenposten* [Evening Post], May 8, 2014, <http://www.aftenposten.no/nyheter/iriks/I-dag-ble-Alexander-28-Norges-hoyest-dekorerte-etter-andre-verdenskrig-7559385.html>.

⁹ Olav Riste, "With an Eye to History: The Origins and Development of 'Stay-Behind' in Norway," *Journal of Strategic Studies* 30, no. 6 (November 2007): 997–1024.

roles and capabilities for Norway's SOF. Today, citizens of Norway, no matter where they are, can rest assured SOF provide the capability and will to rescue them from any worldwide hostage situation.¹⁰ At the present, a well-structured program for individual PR and SERE training has been established for Norwegian aircrews and SOF. An increased capability for educating select army units is evolving.

I have been involved in PR as the Royal Norwegian Air Force (RNoAF) Office of Primary Responsibility (OPR) for PR from 2007 until 2014, when I joined the Defense Analysis program at the Naval Postgraduate School (NPS). Given my last assignment and the Norwegian Armed Forces move toward a whole of Department of Defense (DOD) approach to PR, I chose to use my time as an NPS student to gain in-depth knowledge of PR. I continued my work as the OPR for PR, which offered me an opportunity to support the ongoing PR developments in Norway.

C. CAPSTONE APPROACH

Personnel Recovery was the obvious subject for me to study, and I was fortunate to come across an interesting way to study it. Early on in the NPS Defense Analysis (DA) program, I participated in a practical seminar on design thinking (DT) championed by Dr. Nancy Roberts. The experience of the seminar triggered my interest in design as a culture of inquiry for change, and shortly thereafter, I also participated in a three-quarter-long strategic design challenge sponsored by the Norwegian Special Operations Command (NORSOCOM) that explored how Norwegian Special Operations Forces (NORSOF) could be designed to meet the challenges of 2025.¹¹ Design thinking is a process of problem-solving that is human centered, and with the experience of the NORSOF design challenge, I found design well suited for a capstone approach to my study of PR.

¹⁰ Nils Johan Holte, "Norske spesialstyrker i støpesjeen—hva innebærer reformene?" [Norwegian Special Forces in Development—What are the Implications of Reform?] (speech, Oslo Militære Samfund [Oslo Military Society], Oslo, March 31, 2014), http://www.oslomilsamfund.no/files/speech_files/457-2014-03-31-Holte.pdf.

¹¹ Espen Berg-Knutson and Nancy Roberts, *Strategic Design for NORSOF 2025*, Naval Postgraduate School Technical Report no. NPS-DA-15-001 (Monterey, CA: Naval Postgraduate School, September 2014).

D. CAPSTONE PURPOSE AND STRUCTURE

This capstone project uses design and design thinking as a process of inquiry to model a Norwegian PR system. The 2014 initiative by the Norwegian Chief of Defense (CHOD) designates the RNoAF as the Executive Agent Office of Primary Responsibility (EA OPR) for PR. The goal of this capstone project is to assist the RNoAF in creating a new whole of government approach for the Norwegian PR system.

The remainder of this project is organized as follows. Chapter II describes design as a culture of inquiry for change, and design thinking as a five-step process and method of generating creative ideas and prototyping them to produce innovation. The sponsor's design challenge and the key personnel and stakeholders involved in the project are also introduced.

Chapter III details the first step of design thinking, the discovery phase. Archival records provide the history and context of PR and the foundation for an assessment of the current Norwegian PR system. Discussions with PR actors and participant observations also provide a rich understanding of the many viewpoints on PR and the context of the design challenge. The general themes drawn from the discovery phase conclude the chapter and set the stage for the problem definition phase.

Chapter IV describes the existing challenges of the PR system. It offers a refined problem definition that guides the subsequent chapters on ideation, prototyping, and testing. Chapter V describes the ideation phase and the ideas to be developed into prototypes. Chapter VI offers prototypes of the Norwegian PR system judged to be the most important elements in the redesign of the existing PR system. Finally, Chapter VII summarizes the findings of the capstone project.

THIS PAGE INTENTIONALLY LEFT BLANK

II. DESIGN AND DESIGN THINKING

A. INTRODUCTION

Personnel recovery in the Norwegian Armed Forces is an activity that must be conducted during peacetime, crisis, and war. The establishment of the RNoAF as the EA OPR for PR by the Norwegian CHOD in 2014 has triggered changes in PR.¹² It led to the question that launched this project: How could the Personnel Recovery (PR) system for the Norwegian Armed Forces be designed to enable Norwegian commanders and staffs, forces, and isolated personnel to operate in a Combined Joint Personnel Recovery mission environment?

Design as a culture of inquiry is best suited for this capstone, as it provides for an assessment of the current Personnel Recovery (PR) system, “that-which-is,” by systems analysis and synthesis, and through systems critique, reveals “that-which-ought-to-be,” and by taking prudent action provides the change to “that-which-needs-to-be” or “that-which-is-desired-to-be.”¹³

This chapter provides an introduction to design as a third culture of inquiry and design thinking (DT) as a specific design process.

B. DESIGN

According to Harold Nelson and Eric Stolterman, “design is a natural and ancient human ability, the first tradition among many traditions of human inquiry and action.”¹⁴ In their book *The Design Way: Intentional Change in an Unpredictable World*, Nelson, and Stolterman define design as “the ability to imagine that-which-does-not-yet-exist,

¹² Forsvaret [Norwegian Armed Forces], *Direktiv for luftmilitær virksomhet* [Directive for air operations] (Oslo: Forsvarssjefen [Chief of defense], 2014).

¹³ Harold G. Nelson and Erik Stolterman, *The Design Way: Intentional Change in an Unpredictable World* (London: The MIT Press, 2014), 77.

¹⁴ *Ibid.*, 1.

and to make it appear in concrete form as a new, purposeful addition to the real world.”¹⁵

They expand on design as a core human activity:

When we create new things—technologies, organizations, processes, environments, ways of thinking, or systems—we engage in design. To come up with an idea of what we think would be an ideal addition to the world, and to give real existence—form, structure, and shape—to that idea, is at the core of design as a human activity.¹⁶

Design is a third way, distinct from the arts and sciences.¹⁷ According to Herbert Simon, the difference between science and design is straightforward: “The natural sciences are concerned with how things are; design, on the other hand, is concerned with how things ought to be.”¹⁸

Klaus Krippendorff identifies four points that distinguish scientists:

- Scientific research is essentially re-search, a repeated search for patterns within available data.
- Data always are of past happenings, whether they are found or generated for a purpose, for example, by counting a population or designing a controlled experiment. The patterns that data analysis is presumed to “find” have always existed prior to their analysis.
- Theories generalize what permeates the data—common properties, stable patterns, and underlying causalities. By definition, generalizations omit details that are irrelevant to intended theory. The law of falling bodies, for example, concerns theoretical bodies. Truly unique events, being not generalizable, are of little interest to natural scientists who would rather believe they do not exist. Predictions from past to future always presume that the theorized properties are stable and unchanging within theoretical limits.
- To preserve the idea of nature as an undisturbed object of study, scientific observers are not allowed to enter their domain of observation, are required to remain detached, spectators of happenings, and certainly must not affect the data they intend to analyze. This is to assure that scientific

¹⁵ Ibid., 12.

¹⁶ Ibid., 1.

¹⁷ Ibid., 1.

¹⁸ Klaus Krippendorff, *The Semantic Turn: A New Foundation for Design* (Boca Raton, FL: CRC Press, 2006), 26.

findings, theories, and laws are about an observer-uncontaminated nature.¹⁹

Designers, on the other hand, pursue other motivations, Krippendorff describe these as follows:

- Designers are motivated not by a quest for knowledge for its own sake but by challenges, troublesome conditions, problems, or conflicts that have escaped (re)olution; opportunities to change something for the better—not recognized by others—to contribute to their own or other communities' lives; possibilities to introduce variations into the world that others may not dare to consider, creating something new and exciting—just as poets, painters, and composers do—aimlessly and for fun.
- Designers consider possible futures, worlds that can be imagined and could be created in real time. They are concerned less with what has happened, what already exists, or what can be predicted by extrapolation from the past than with what can be done. Designers' most outstanding ability is not being afraid to explore new ideas, to challenge theories that claim that something cannot be done, or to question what is commonly taken for granted. Thus conceived, the futures that designers envision are inherently unpredictable from laws of nature, though not necessarily contradicting them.
- To choose among them, designers evaluate the desirability of these futures. Desirable worlds must make sense and be of benefit to those who could realize these worlds and might come to live in them. Developing a consensus on the desirability of a possible future calls for deliberations among its stakeholders, using a language that is capable of going beyond data or facts.
- Designers search the present for variables, things they are able to vary, move, influence, alter, combine, take apart, reassemble, or change. These variables define a space of possible actions, a design space, as Phil Agre (2000) calls it. Designers need to know the efforts required to alter these variables and how likely they are in bringing forth desirable futures (and avoiding undesirable futures).
- Designers create and work out realistic paths from the present toward desirable futures and propose them to those who can bring a design to fruition. Successful designs depend on designers' ability to enroll stakeholders into their projects, even if these stakeholders pursue their own interest as well. The paths that designers invite stakeholders to take must be presented as realistic, affordable, of benefit to those whose effort

¹⁹ Ibid., 27.

is required, and above all, open valuable opportunities to those affected by a design.²⁰

Nelson and Stolterman advance “the case for design as its own tradition, one that reintegrates *sophia* rather than following the historical Western split between science and craft or, more recently between science and the humanities.”²¹ The word *philosophy* means “love of wisdom” from its two roots *philo* (love) and *sophia* (wisdom). The original definition of *sophia* is the *knowing hand*. The knowing hand is an integration of thinking and action, as well as reflection and production.²² *Sophia* signifies the skill of a craftsman. This integrated meaning of *sophia* would later split into theory and practice, where thinking gained a higher value or status than practice, and this split is evident and present today.²³

The philosopher Charles Sanders Peirce argues that “no new idea could be proved deductively or inductively using past data.”²⁴ There has to be a third kind of logic. Peirce named the third type of reasoning, abductive logic, that does not have a goal of declaring a conclusion true or false, but to infer what could possibly be true. Relating this to design means “the ability to imagine that-which-does-not-yet-exist.”²⁵

Thus, Nelson and Stolterman view design as an integration of reason and observation, reflection, imagination, action, and production. It includes not only creative thinking but also innovative, productive, and compositional activities.²⁶ They further state that “design is realized through the manifestation and integration of ideal, if not always creative, concepts into the real world,” that design is, “a compound of rational, ideal, and pragmatic inquiry,” and as such “is constituted of reflective and critical thinking, productive action, and responsible follow-through.”²⁷

²⁰ Ibid., 28.

²¹ Nelson and Stolterman, *Design Way*, 1.

²² Ibid., 14.

²³ Ibid., 14–15.

²⁴ Roger Martin, *The Design of Business* (Boston: Harvard Business Press, 2009), 64.

²⁵ Nelson and Stolterman, *Design Way*, 12.

²⁶ Ibid., 4.

²⁷ Ibid., 5.

Nelson and Stolterman also claim that “the process of design is always the most effective and efficient means of getting organizations and individuals to new places. Design is therefore about leadership—and leadership is therefore an essential element of any design culture.”²⁸ Today’s complex world demands that leaders possess the ability to act, despite an overload of incomplete “information within restrictive limits of resources and time,”²⁹ and calls for the use of sound judgment, not necessarily just traditional problem-solving. Nelson and Stolterman argue that leaders and designers are often one and the same. Leaders’ challenges are to determine the direction and destination of the organization via the design tradition.³⁰

As seen in Figure 5, design drives change by an assessment that describes and explains that-which-is through systems analysis and synthesis, followed by a systems critique that identifies that-which-ought-to-be, as well as that-which-should-be.

<i>assessment</i>		<i>change and design</i>		
systems apposition	systems analysis/ synthesis	systems critique	systems restoration	systems redesign design
that-which-is		that-which- ought-to-be	that-which- needs-to-be	that-which-is- desired-to-be
• describe • explain		• critique	• repair	• reform • transform • form

Figure 5. Assessment, Change, and Design³¹

²⁸ Ibid., 5.

²⁹ Ibid., 5.

³⁰ Ibid., 5.

³¹ Ibid., 77.

The assessment sets the stage for change and design that can be a systems restoration, a repair to that-which-needs-to-be; or a systems redesign, a design that reforms, transforms, or forms that-which-is-desired-to-be.³² That-which-is-desired-to-be is, therefore, the specific end outcome of design. If the recommendations of this capstone are accepted by the PR community and survive additional follow-on testing and implementation, the result will be a new, innovative PR system for Norway.³³

C. DESIGN THINKING

No common definition of design thinking (DT) exists, but the definition that informs this capstone is one offered by Professor Nancy Roberts of the Naval Postgraduate School in Monterey, CA: DT is “a cross-disciplinary, human-centered, collaborative process for the purpose of creating designs—new products, processes, services, strategies, organizations, and systems.”³⁴ As the Stanford d.school elaborates, DT is a “methodology for innovation that combines creative and analytical approaches, and requires collaboration across disciplines,” and that DT “draws on methods from engineering and design, and combines them with ideas from the arts, tools from social sciences, and insights from the business world.”³⁵

DT was selected to guide this capstone project due to its focus on human-centered design that searches for solutions that are desirable, feasible, and viable. By starting with humans and their hopes, fears, and needs, one can discover what is most desirable. Then the question becomes what is technically feasible to implement and what is financially viable in the long term.³⁶ These three lenses of human desirability, technological feasibility, and

³² Ibid., 6.

³³ Innovation is the adoption of a new practice in a community as defined in Peter J. Denning and Robert Dunham, *The Innovator's Way: Essential Practices for Successful Innovation* (London: The MIT Press, 2010), 6.

³⁴ Nancy Roberts, “Strategic Design” (lecture, Naval Postgraduate School, Monterey, CA, February 25, 2016).

³⁵ d.school, “Our Point of View: Our Way of Working,” last modified April 25, 2016, <http://dschool.stanford.edu/our-point-of-view/>.

³⁶ Ideo.org, *The Field Guide to Human-Centered Design* (San Francisco: Ideo.org., 2015), 14.

financial viability, as seen in Figure 6, represent the initial constraints that are visualized as three overlapping criteria for turning successful ideas into design solutions.³⁷

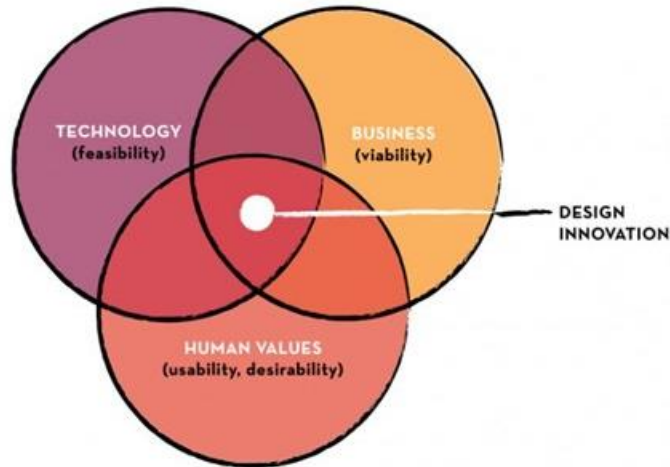

Figure 6. Stanford d.school Human-Centered Design³⁸

All of these elements must be carefully balanced to develop design solutions that are successful and sustainable.³⁹

The five-phase model of DT, as seen in Figure 7, was developed and continues to evolve at Stanford’s Hasso Plattner Institute of Design (d.school), which was founded in 2005 by David Kelley.⁴⁰

³⁷ Ibid.; Tim Brown, *Change by Design: How Design Thinking Transforms Organizations and Inspires Innovation* (New York: Harper Collins, 2009), 18.

³⁸ d.school, “Our Point of View.”

³⁹ Ideo.org, *The Field Guide to Human-Centered Design*, 14; Brown, *Change by Design*, 18.

⁴⁰ Literature on Design as a culture of inquiry and design thinking is evolving and an overview of this literature can be found in Appendix B.

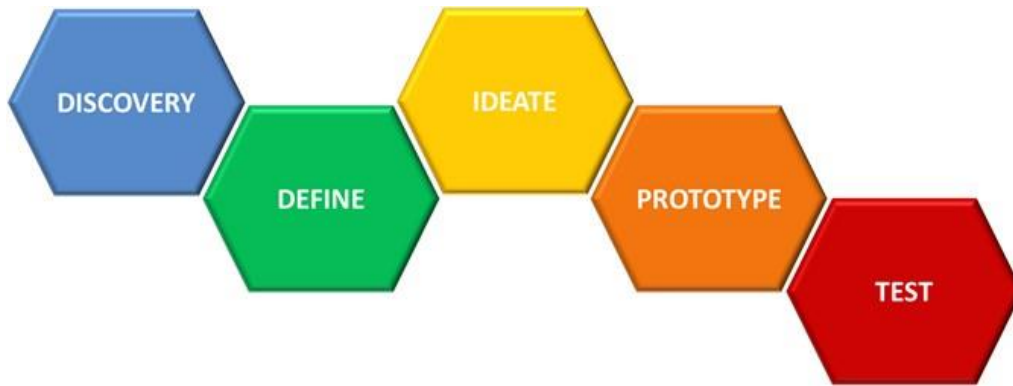

Figure 7. The Design Thinking Process I⁴¹

1. The Design Challenge

A design challenge launches the DT process. The designer, working with a sponsor or client, decides on an issue, question, or problem of interest. In this instance, the design challenge is how the PR system could be designed or redesigned to enable Norwegian commanders, staff, forces, and isolated personnel to operate in a Combined Joint PR mission environment.

2. Discovery Phase

The *discovery* phase initiates the design thinking process. The intent of discovery explores the military, economic, political, and social context in which the design challenge resides, with an emphasis on the stakeholders who are part of the PR system. This phase constitutes the cornerstone of the human-centered design process.⁴² The objective is to “understand the way they [people] do things and why, their physical and emotional needs, how they think about their world, and what is meaningful to them.”⁴³

There are numerous ways to make sense of and learn about the context and the specific design challenge: examination of archival records, observations of people in their

⁴¹ Stanford d.school’s design thinking process, as modified by Nancy Roberts. Nancy Roberts, “The Design Thinking Process” (PowerPoint presentation, Design Thinking course, Naval Postgraduate School, Monterey, California, 2014).

⁴² See section on Empathy in d.school, “The Design Process Mini-Guide,” d.school, August 2, 2012, https://dschool.stanford.edu/groups/designresources/wiki/36873/Design_Process_MiniGuide.html.

⁴³ See section on Empathy in d.school, “Design Process Mini-Guide.”

design environment, and discussions with the key stakeholders. The goal of the discovery phase is to observe, listen to, and learn from the people involved in the PR system to understand their perspectives and to gain a deep understanding of their experiences.

3. Problem Definition Phase

The *define* phase of the design process reframes the design challenge based on the synthesis of the various findings from the empathy work in the discovery phase. Based on the insights gained, the define phase brings focus and clarity to the collected data, observations, and discussions, and identifies a key issue or problem the design team will leverage in ideation.⁴⁴

4. Ideation Phase

The *ideate* phase of the design process generates new ideas. By launching brainstorming sessions with “how might we” questions, the objective is to encourage new and different ideas to address the problem or issue identified in the define phase. The underlying premise is that participants defer judgment by separating idea generation from the evaluation of ideas. From brainstorming, one moves to assessment where the design team selects some of the best ideas to go forward into the prototyping phase.⁴⁵

5. Prototyping Phase

The design team launches this phase by selecting one idea they believe merits *prototyping*. The prototyping phase can range from making simple physical models of a new product to a storyboard for a process or an operation or a simple “rock drill” or a simulation. The idea is to make it quick, cheap, and rough, so that if it fails, one can fail early and fail often to learn faster.⁴⁶ The prototypes for this capstone have been developed in the form of a storyboard that visualizes a possible future PR journey for the main stakeholders within the Norwegian PR system and how these stakeholders will act

⁴⁴ See section on Define in d.school, “Design Process Mini-Guide.”

⁴⁵ See section on Ideation in d.school, “Design Process Mini-Guide.”

⁴⁶ The concept of cheap and rough prototypes lowers the cost of failure and provides an opportunity to learn from mistakes early in the process and to change direction before the consequences and commitments become too big and costly.

and function within that framework for the preparation, planning, execution and adaptation phase.

6. Testing Phase

The last step in the DT process is *testing*. The goal is to get stakeholder feedback quickly to find any flaws in the prototype and then, just as quickly, come up with new ideas to correct or further develop the prototype. Based on user feedback, the design team will be able to find out what works, what can be improved, what additional questions users have, even some new ideas they may generate. Testing is one more chance to understand the user's need and often offer new unexpected insights.⁴⁷

The Norwegian design team will “test” the future Norwegian PR system prototype with identified key stakeholders in the different service branches to gain insights and feedback on the desirability, feasibility, and viability of the suggested prototype. This will be an iterative process that seeks to improve the prototype. The idea will be further developed to design a new prototype that will be sustainable with the restraint and constraints of a small nation's armed forces.

D. DESIGN THINKING AND PROBLEM-SOLVING

The DT process, from discovery to testing, is, for simplicity, articulated as a linear progression. In reality, the process continually goes back and forth between and among the phases as new understanding and insights appear from a continuous synthesis of the design challenge and potential future solutions. Figure 8 provides another illustration of the DT process that visualizes its non-linear attributes and also includes an implementation process.

⁴⁷ See section on Testing in d.school, “Design Process Mini-Guide.”

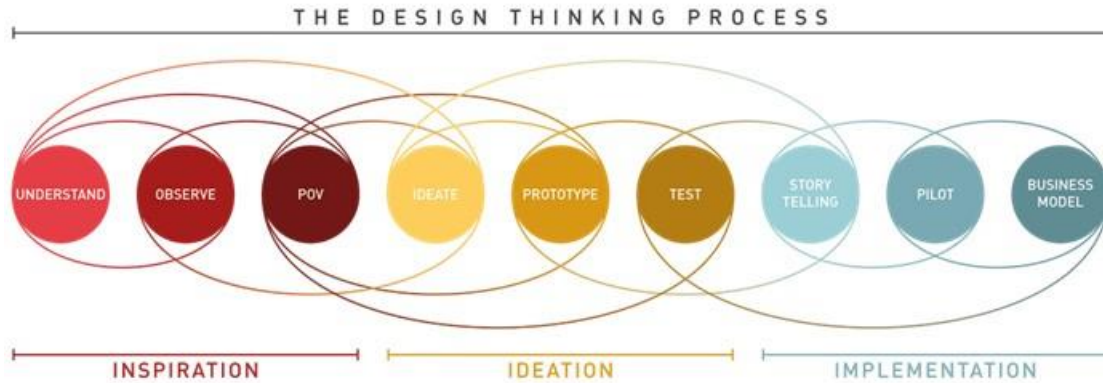

Figure 8. The Design Thinking Process II⁴⁸

DT also captures the way individuals tend to think. Western thought and problem-solving tend to prioritize logic and deduction, where people are prone to take a series of inputs, analyze them, and converge on a single answer. “Convergent thinking is a practical way of deciding among existing alternatives,” but not so effective for exploring new possibilities.⁴⁹ By contrast, “the objective of *divergent* thinking is to multiply options to create more choices.”⁵⁰ The idea then is to create many ideas, ultimately settling on a *good idea*.⁵¹

As shown in Figure 9, both processes are necessary and are captured in DT.

⁴⁸ d.school.fr, accessed April 25, 2016, <http://www.dschool.fr/wp-content/uploads/2014/08/DesignThinkingProcess.png>.

⁴⁹ Brown, *Change by Design*, 66.

⁵⁰ Ibid.

⁵¹ Ibid., 7.

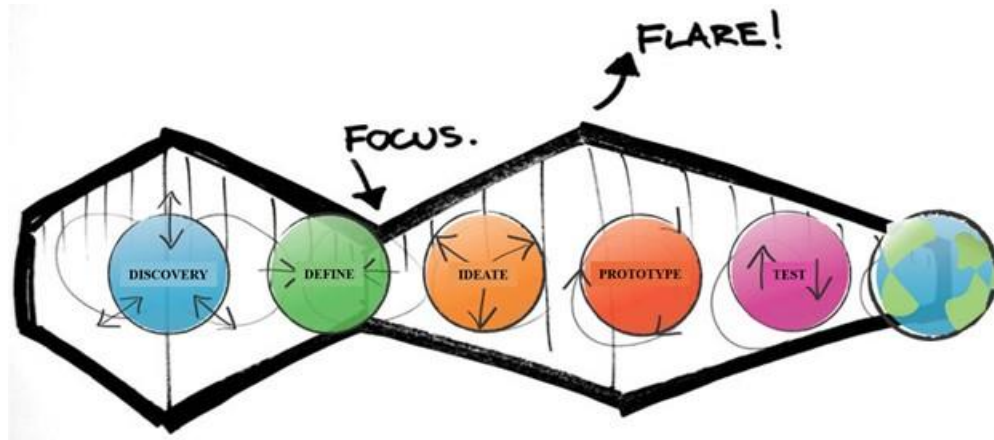

Figure 9. The Design Thinking Process III⁵²

There is a constant exchange between divergent and convergent thinking, where divergence begins with discovery, converges with the define phase, diverges again with Ideation, and converges with Prototyping and Testing. If the prototypes are not viable or accepted, the process repeats itself.⁵³

Thus divergent thinking complements convergent thinking just as analysis complements synthesis. Analysis uses inductive and deductive logic to derive an efficient solution from past data, while synthesis is the creative process. The team’s collective action is to make sense of the data and draw inferences to that-which-does-not-yet-exist and could be.⁵⁴ Synthesis is, according to Tim Brown, the creative “act of extracting meaningful patterns from masses of raw information.”⁵⁵ Like divergent and convergent thinking, synthesis and analysis are equally important to DT in the process of creating options and making choices.

⁵² “How Does the d.school’s Framework for Design Thinking Map into IDEO’s?” Ux.stackexchange, accessed April 25, 2016, <http://ux.stackexchange.com/questions/73630/how-does-the-d-schools-framework-for-design-thinking-map-onto-ideos>.

⁵³ Brown, *Change by Design*, 68.

⁵⁴ Nelson and Stolterman, *Design Way*, 132.

⁵⁵ Brown, *Change by Design*, 70.

E. THE NORWEGIAN PR CAPSTONE PROJECT

1. Key Personnel

There are several people with different roles and responsibilities who are involved in this capstone project and whose contributions and perspectives have shaped the outcome of the design project. The main contributors and actors are as follows.

a. Design Team

The design team was initially planned to be a core team of representatives from the PR community of the Norwegian Armed Forces. Due to the difficulties of gathering everyone at one physical location, and thus adhering to a pure design thinking process of physical collaboration, a hybrid model of a design team has been used. The core members have been the RNoAF PR and SERE school instructors and staff that were available to meet when I traveled to Norway. Most often, the team meetings have been with one or two of them at a time, and as the designer, I have assumed the responsibility for the overall synthesis of our meetings. The RNoAF instructors and staff have provided input from the many other actors and stakeholders in Norway and made the essence of their discussions available for me to gather as a whole. Communication has been conducted through Skype and similar means to clarify important issues.

b. Sponsor

The commander of the RNoAF PR and SERE School, Lieutenant Colonel Christian “Spirit” Waldermo, has been the formal sponsor of the project, as he is tasked by the inspector general of the Air Force to develop the RNoAF as the EA OPR of PR for the Norwegian Armed Forces.

c. Designer

As a novice student of design myself, I have had the full support of Dr. Nancy Roberts who, as an expert in strategic design, has provided invaluable direction and insight to this capstone project.

d. Stakeholders

The perspectives of the various actors and stakeholders in the PR system depend very much on their location in the PR system. The difficulty of seeing the whole of a situation has been recognized for thousands of years as the famous tale of the blind wise men and the elephant warns of the limits of a single point-of-view.⁵⁶ As each of the wise men touches the elephant for the first time, and from different positions, they all come up with a different answer as to what an elephant is, as seen in Figure 10.

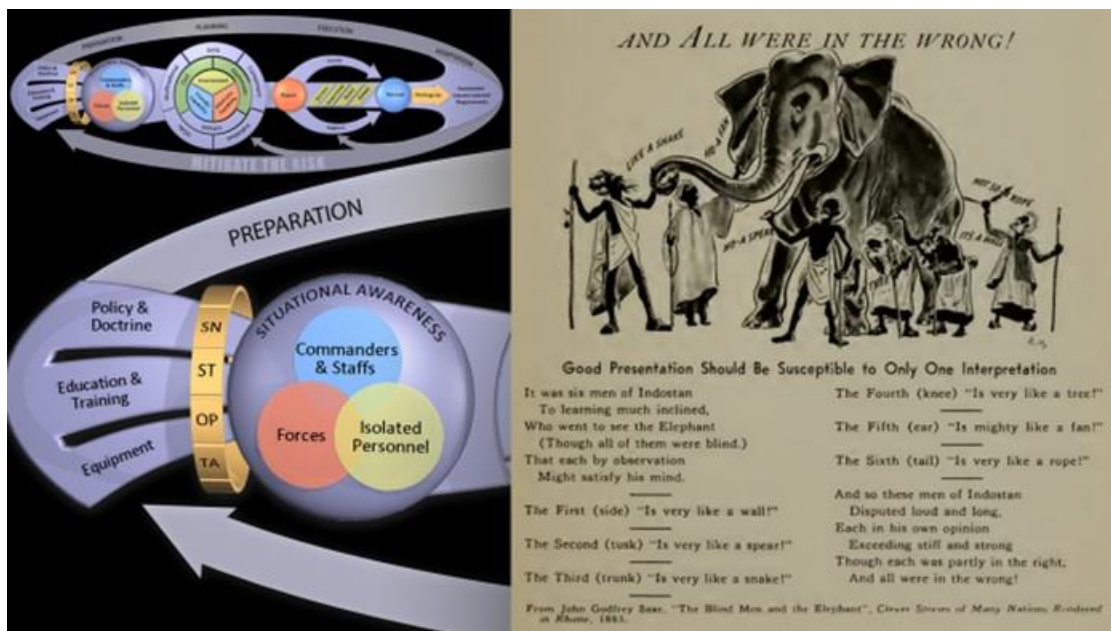

Figure 10. Seeing the Whole of Systems

The famous tale of the blind wise men and the elephant demonstrates the limits of the positional, or a singular point-of-view perspective to explain the whole.⁵⁷ The same challenge of seeing the whole has been the case for PR as it has evolved from WWII to the present. As an example, there are many actors from all services who talk about PR with similar but still different terms, and the various services differ in how they label and

⁵⁶ Ibid., 66.

⁵⁷ Ibid., 65; Willard Cope Brinton, *Graphic Presentation* (New York: Brinton Associates, 1939), 13; "Graphic Presentation by Willard Cope Brinton," Archive.org, accessed April 25, 2016, <https://archive.org/details/graphicpresentat00brinrich>.

conceptualize the PR system. The Air Force and Navy use the term CSAR; the United States Marine Corps (USMC) calls it tactical recovery of aircraft and personnel (TRAP), and SOF does hostage rescue.⁵⁸

There are also several actors and stakeholders in the PR system, and the most obvious ones are found in the roles of isolated personnel, rescue forces, and commanders and staffs. There are two types of rescue forces, those that have PR as a primary mission as a *dedicated* force and those who provide support and rescue efforts as a *capable* force.⁵⁹

Commanders and staffs can also be said to belong to two categories: those in the PR C2 architecture with dedicated PR roles and training, or those in the command chain as unit and higher headquarters leaders and staffers who set the stage or PR from the preparation phase through the planning, execution, and adaptation phases of the model.

The preparation phase of the PR model also indicates that there are numerous supporting actors involved who “own” policy and doctrine, and education and training institutions, and those who provide the essential PR and SERE equipment.

A very important stakeholder in the system is the family of the involved actors, especially the isolated personnel in distress, as the model also emphasizes the support task where both isolated personnel and their families are addressed in the doctrine.

At one end of the spectrum, the isolated personnel is the primary reason for PR. At the other end are the national leaders. They have responsibility for sending people into harm’s way and are concerned for the political consequences of “failed” rescues,⁶⁰ and the media attention to “tactical” PR incidents. They also bear the moral responsibility to the society for doing their best to recover those who serve on behalf of others.

⁵⁸ Chairman, Joint Chiefs of Staff (CJCS), *Personnel Recovery*, JP 3-50 (Washington, DC: CJCS, 2011), I-4.

⁵⁹ Examples of Norwegian *dedicated* forces are Norwegian Special Forces (Hostage Rescue) and the 330 Search and Rescue (SAR) Squadron (SAR). Examples of *capable* forces are F-16 fighters providing Close Air Support to isolated personnel and C-130 transport aircraft providing resupply to isolated personnel.

⁶⁰ Examples of “failed” rescues are the Son Tay Raid in the Vietnam War, the Mayaguez incident, and Operation Eagle Claw, the rescue attempt in Iran.

As one can see when adopting multiple perspectives, the “sponsor” of the capstone is just a proxy client for a more varied group of stakeholders. If one assumes a broader perspective, one can also argue that the PR system not only serves the present but is also designed for future clients and past clients who learned their PR lessons at the cost of both blood and treasure.

2. Design Challenge

Every nation that engages in armed conflict has a moral responsibility and commitment to leave no man behind. “PR is the sum of military, diplomatic, and civil efforts to prepare for and execute the recovery and reintegration of isolated personnel.”⁶¹ As a small nation, Norway must be able to prepare its soldiers for PR and be able to participate in PR operations during national operations or as part of a multinational coalition.

a. PR Executive Agent Office of Primary Responsibility

In 2014, the CHOD of the Norwegian Armed Forces delegated the equivalent of an Executive Agent Office of Primary Responsibility (EA OPR)⁶² for PR to the Inspector General of the Royal Norwegian Air Force (RNoAF).⁶³ Within the RNoAF, the service OPR for PR is the RNoAF PR and Survival, Escape and Evasion, Resistance and Extraction (SERE) School, which is organizationally placed as an entity under the commander of the RNoAF Tactical Flying School. Good sponsorship and support are essential factors in establishing a design challenge. This capstone project has been fortunate to have the commander of the RNoAF Tactical Flying School, Lieutenant Colonel Christian “Spirit” Waldermo, as the sponsor. The support from the RNoAF

⁶¹ CJCS, *Personnel Recovery*, ix.

⁶² A term used to indicate a delegation of authority by the secretary of defense or deputy secretary of defense to a subordinate to act on behalf of the secretary of defense. Also called EA. EA OPR is the closest translation to the Norwegian term *fagmyndighet*.

⁶³ The definition of *fagmyndighet* translates to “the responsibility and authority to establish requirements and specify disciplinary frames within a given area of activity for the entire military, including developing the area of activity, be the subject matter professional consultants in this area of activity, as well as carrying out checks and issue orders to resolve any discrepancies. Parts of authority may be further delegated as *professional responsibility*.” Forsvaret [Norwegian Armed Forces], *Direktiv for luftmilitær virksomhet* [Directive for air operations], 4.

SERE School Commander Major Frode “Bilbo” Martinsen, the chief SERE instructor Captain Frode Sjaastad, and his instructor staff has been most valuable and appreciated.

b. Sponsor Guidelines

The sponsor provided support to the Capstone Project to assist in the development of a comprehensive Department of Defense approach to PR in Norway, with the RNoAF as the EA OPR for PR. They also requested that the capstone be aligned with current organizational and economic constraints broadly experienced by the Norwegian Armed Forces and address the needs of the personnel involved in PR.

After consultations, sponsors agreed to the following design challenge:

How can we design a PR system for the Norwegian Armed Forces to enable Norwegian *commanders and staffs, forces, and isolated personnel* to collaborate and to operate in a PR mission environment during peace, crisis, and war?

3. Design Constraints

The biggest constraints to the design project have been the physical distance and the nine-hour time zone difference, both of which have challenged the traditional design team face-to-face configuration and caused me to act for the most part as the lead designer, responsible for coordinating input from the other design team members.

4. The Norwegian Armed Forces Personal Recovery Network Design Thinking Process

a. Discovery

The discovery phase began with archival research on the PR system as the model is described today by the United States and NATO. The vast history of PR was examined from the perspectives of the individuals rescued, the rescue forces, and their organizations to demonstrate the strategic impact of PR. Research on PR policy and doctrine also provided valuable insights about PR’s evolution. The discussions and participant observations with the PR actors supplemented the archival research to provide a comprehensive overview of the Norwegian PR system.

b. Problem Definition

This phase opens with a critique of the current PR system. It concludes with the reframed design challenge and offers questions to initiate ideation.

c. Ideation

Based on the results of the systems critique and problem definition, ideation generates new ideas on how we might go about restoring or redesigning the future Norwegian PR system. The ideas judged to have the most potential for stakeholders were selected.

d. Prototyping

The prototyping phase expanded on the initial ideas that were found the most prudent and developed them into viable options to consider for the stakeholders and PR change agents, with focus on specific options that would directly support the ongoing efforts of the RNoAF PR and SERE school in their efforts to develop a DOD-wide approach to PR

e. Testing

The low-resolution prototypes were “tested” with the design team and a limited number of Norwegian key PR actors; they were tested as to their viability, feasibility, and desirability in supporting the RNoAF OPR for PR’s continuing development of the Norwegian Armed Forces PR system. The prototype-testing phase is expected to continue from August to December 2016 as a sponsored project of the RNoAF EA PR.

The next chapters guide the reader through a linear illustration of what has been a challenging and most non-linear real life process of design.

III. DISCOVERY

A. INTRODUCTION

The discovery phase of the design thinking (DT) process utilized a mixture of archival research, discussions, and participant observations with the principal actors and stakeholders currently involved in PR. It involved what Neustadt and May call “thinking in time.”⁶⁴ Neustadt and May argue that by looking back to the past, one can better understand the present and make better decisions today about the future.⁶⁵ Thinking in time offers ways to use experience—both one’s own and that of hundreds of others from the historical past—to determine how best to make decisions *now*, in a real and imperfect world. By looking back to look forward, thinking in time enables insights about what can be accomplished in the future. Thinking in time is therefore “about how to *use* experience, whether remote or recent, in the process of deciding what to do today about the prospect for tomorrow.”⁶⁶ In this manner, the discovery phase sought to identify and understand the experiences of people involved in PR from WWII to the present. Taken together, their experiences provide a thorough understanding of the human needs and desires that guide this DT project.⁶⁷

1. Overview of Sources

Design thinking, especially in the initial discovery phase, calls for a human-centered approach to design that explores the needs of the people involved in PR. In particular, I focused on isolated personnel who have had to survive, escape and evade the enemy, and in many cases endure captivity and resist interrogation when the rescue forces were not able to get them out of harm’s way. I also have sought insights from the

⁶⁴ Richard E. Neustadt and Ernest R. May, *Thinking in Time: The Uses of History for Decision-Makers* (New York: The Free Press, 1986), xxii.

⁶⁵ *Ibid.*

⁶⁶ *Ibid.*

⁶⁷ Appendix A lists all the literature used in the initial discovery phase in chronological order from WWII until the present day. By grouping the literature according to wars and operations with as many perspectives as possible, it was possible to recognize patterns and evolutions within the development of PR that serve as a solid foundation of knowledge and lessons from the past, thereby enabling progress toward building the future Norwegian PR system through the rest of the design thinking process.

wide variety of rescue forces involved in PR and when their perspectives were available, relied on the commentary of commanders and staffs of rescue operations. In addition to the education and training effort of PR forces, I explored their technology, organizational, and doctrinal descriptions as they evolved over time.⁶⁸

My exploration of the western PR archival records tapped into many sources.

- I explored the current doctrinal view of PR from the perspective of the United States, NATO, and non-NATO nations to understand how the various nations describe and define PR and identify the key actors and stakeholders.
- After identifying the key people and actors involved in PR, I read background material about their experiences from WWII to the present.
- Additional explorations of key stakeholders in PR led me to understand the link between the development of the Joint Special Operations Command (JSOC) and the United States Special Operations Command (USSOCOM), which highlighted PR's strategic importance.
- I then reviewed the historical record of PR doctrine and its evolution from WWII to the present.
- Against the backdrop of western PR development, I then turned my focus to Norway's PR history.
- Based on the insights gained during these first five steps, I began to explore the connections between the current Norwegian PR actors. Ultimately, I came to understand their connections from a network perspective.

After exploring PR archival records in depth, I turned to discussions and participant observations:

- I held discussions with current participants engaged in PR from the RNoAF PR and SERE School, the Army SERE School, and the Norwegian Conduct after Capture training unit, and from the SOF community.
- As a long time participant at various levels in the PR system, I also summarized my own experiences in PR.

⁶⁸ An exhaustive chronological list of this literature is found in Appendix A. In addition to the education and training effort of these groups of people, technology, organizational, and doctrinal description and development are also examined as PR has evolved over time.

B. ARCHIVAL RECORDS

1. Doctrinal Overview of PR: United States and NATO

The core tasking of the capstone project is to design a PR system for the Norwegian Armed Forces that enables Norwegian isolated personnel, forces, and commanders and staffs to function in a PR mission not only within Norwegian territory but also as a part of a multinational coalition. Interoperability with coalition forces to solve a PR mission is critical to a successful outcome since Norway, as a small nation, has limited resources. Therefore, Norway must look to the larger nations and allies and adapt closely to a standard concept and model of PR. Most Norwegian military international operations will be under a NATO or a U.S.-led coalition of nations, as has been the case for the last two decades. When it comes to PR, the United States has been the leading nation, and NATO has carefully adopted its doctrine and aligned with the U.S. model. From WWII to the present day, the origins of PR that grew out of the British MI9, Military Intelligence Service–X (MIS–X), and Special Operations Executive (SOE) have been further developed by the United States through lessons learned in Korea, Vietnam, Cambodia, Iran, Somalia, Iraq, the Balkans, and the last decade of fighting in Afghanistan, Iraq, Libya, and Syria. The literature indicates that there has been a continuous innovation of PR, which seems to have shifted in cycle with the ongoing conflicts and the post-conflict force reductions and build-ups.

As a baseline for the discussion on PR, this capstone looks at the development of the U.S. and NATO PR that could influence and drive the development of the Norwegian system. It recognizes the challenges, disadvantages, and advantages a small nation like Norway will face in building a sustainable PR system. The review of the current and historical literature on PR shows that the most mature PR system, not surprisingly, is the U.S. Department of Defense (DOD) PR system model. The latest DOD and NATO doctrine on PR are used as references to frame the evolution of PR.

The U.S. Joint Publication (JP) 3-50 *Personnel Recovery* of December 20, 2011, defines PR as a system:

Personnel Recovery is the sum of military, diplomatic, and civil efforts to prepare for and execute the recovery and reintegration of isolated personnel.⁶⁹

Isolated Personnel are those U.S. military, Department of Defense (DOD) civilians, and DOD contracted employees and others designated by the President or SecDef who are separated from their unit, as an individual or group, while participating in a U.S. sponsored military activity or mission and who are, or may be, in a situation where they must survive, evade, resist, or escape.⁷⁰

Survival, Evasion, Resistance, and Escape consists of actions performed by isolated personnel designed to ensure their health, mobility, safety, and honor in anticipation of or preparation for their return to friendly control. Also called SERE.⁷¹

In 2007, U.S. joint doctrine was updated for consistency with DOD policy on the joint PR system.⁷² The new JP 3-50 *Personnel Recovery*, January 5, 2007, consolidated relevant guidance: JP 3-50.2 *Doctrine for Joint Combat Search and Rescue*, January 26, 1996; JP 3-50.21 *Joint Tactics, Techniques, and Procedures for Combat Search and Rescue*, March 23, 1998; and JP 3-50.3 *Joint Doctrine for Evasion and Recovery*,

⁶⁹ UK definition: “The aggregation of military, civil, and political efforts to obtain the release or recovery of personnel from uncertain or hostile environments and denied areas whether they are captured, missing, or isolated. JPR includes SAR, DSAR, CR, CSAR, Unconventional Assisted Recovery (i.e., hostage rescue) and associated Survival, Evasion, Resistance, and Extraction (SERE) training, and Care After Recovery (CAR).” Ministry of Defence, *Joint Personnel Recovery*, JWP 3-66 (London: Ministry of Defence, 2003).

⁷⁰ The U.S. definition differs slightly from the NATO definition: “Military or civilian personnel who are separated from their unit or organization in a situation that may require them to survive, evade, resist exploitation, or escape while awaiting recovery.”

⁷¹ The NATO definition is slightly different with an emphasis on extraction. “Survival, Evasion, Resistance and **Extraction**: Defines the set of tactics, techniques, and procedures that will give isolated personnel the tools to survive in any environment and to evade capture where such a threat exists. Failing that, to resist exploitation by captors and, if the situation permits, escape captivity to finally support their own or assisted recovery and return with dignity.” North Atlantic Treaty Organization (NATO), *The NATO Survival, Evasion, Resistance and Extraction (SERE) Training Standard* (STANAG 7196 SD 05) (Brussels: NATO Standardization Office, 2014).

⁷² CJCS, *Personnel Recovery*, iii.

September 6, 1996.⁷³ The concept of addressing PR as a system is introduced in joint doctrine and further expanded on in *JP 3-50 Personnel Recovery*, December 20, 2011.⁷⁴

The 2002 National Security Presidential Directive (NSPD) -12, *U.S. Citizens Taken Hostage Abroad* and its Annex 1, *U.S. Policy on Personnel Recovery and the Prevention of Hostage Taking and Other Isolating Events*, provided presidential level guidance that expanded the PR responsibilities. It included all United States government (USG) department and agencies and created a whole of government approach to PR.⁷⁵ The NSPD-12 was replaced and revoked by the 2015 Presidential Policy Directive (PPD)-30, *U.S. Nationals Taken Hostage Abroad and Personnel Recovery Efforts*.⁷⁶

The Joint Personnel Recovery Agency (JPRA) introduced the visual of the DOD Personnel Recovery System adopted by NATO.⁷⁷ The JPRA PR system model serves as a framework for this capstone and is seen in Figure 11.⁷⁸

⁷³ Ibid. See also CJCS, *Doctrine for Joint Combat Search and Rescue*, JP 3-50.2 (Washington, DC: CJCS, 1996); CJCS, *Joint Doctrine for Evasion and Recovery*, JP 3-50.3 (Washington, DC: CJCS, 1996); and CJCS, *Joint Tactics, Techniques, and Procedures for Combat Search and Rescue* (JP 3-50.21) (Washington, DC: CJCS, 1998).

⁷⁴ CJCS, *Personnel Recovery*.

⁷⁵ George W. Bush, *United States Citizens Taken Hostage Abroad*, NSPD-12 (Washington, DC: The White House, 2002); William J. Rowell, "Whole of Government Approach to Personnel Recovery" (master's thesis, United States Army War College, 2012).

⁷⁶ Barack Obama, *U.S. Nationals Taken Hostage Abroad and Personnel Recovery Efforts*, PPD-30 (Washington, DC: The White House, 2015); White House, Office of the Press Secretary, "Presidential Memorandum: Presidential Policy Directive—Hostage Recovery Activities," The White House, June 24, 2015, <https://www.whitehouse.gov/the-press-office/2015/06/24/presidential-policy-directive-hostage-recovery-activities>.

⁷⁷ NATO, *Allied Joint Doctrine for Recovery of Personnel in a Hostile Environment*, AJP-3.7, Edition A, Version 1 (Brussels: NATO Standardization Office, 2016), 2-2.

⁷⁸ The DOD PR system model is explained in CJCS, *Personnel Recovery*, I-3. NATO has introduced the same JPRA PR System Model with a slight modification to the SERE acronym where the last E for evasion is replaced by *extraction*.



“PR is a system in which the objectives are to return isolated personnel to duty, sustain morale, increase operational performance, and deny adversaries the opportunity to influence our military strategy and national will by exploiting the intelligence and propaganda value of isolated personnel. It is a system comprised of four functions: preparation, planning, execution, and adaptation.”⁷⁹

Figure 11. PR System Model⁸⁰

Preparation Function. PR history illustrates that success in PR is far more likely if the people involved have received proper training on equipment, techniques, and procedures, and are organized and employed in a manner that enables a common operational picture and situational awareness. The key force elements involved in a PR mission are isolated personnel, rescue forces, and commanders and staffs. Each of these force elements must be equipped, trained, organized, and provided with sound doctrinal guidance to be able to execute the five PR execution tasks of report, locate, support, recover, and reintegrate.⁸¹ Depending on where an individual actor is located in the PR system, perspectives range from the strategic national, strategic theater, and operational levels to the tactical levels. Figure 12 illustrates the preparation function of the PR system model.

⁷⁹ To maintain clarity in description, the exact description of PR found in CJCS, *Personnel Recovery*, I-2, is used to describe the model and each of its functions.

⁸⁰ NATO, *Allied Joint Doctrine for Recovery of Personnel*.

⁸¹ CJCS, *Personnel Recovery*, I-3–I-4.

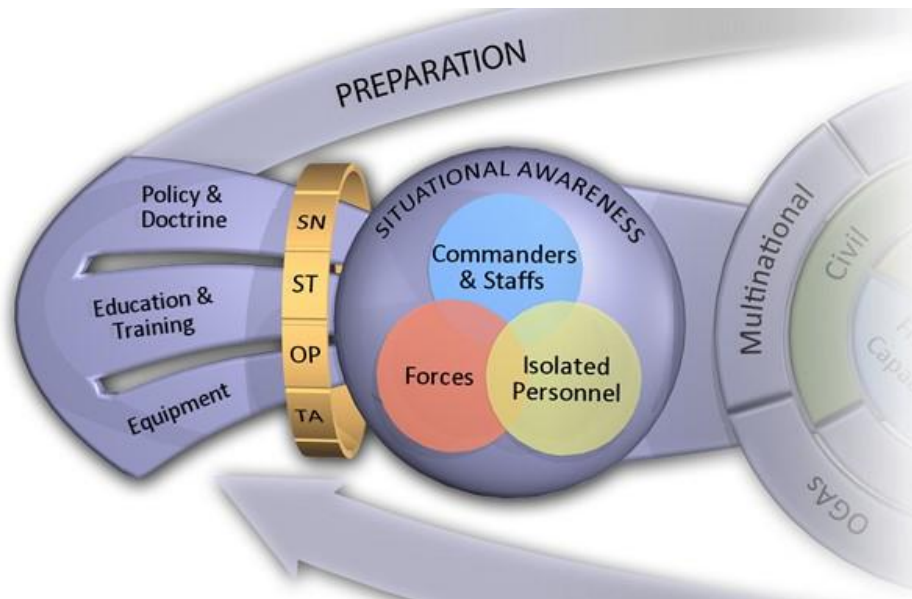

“The system prepares three elements: commanders and staff, recovery forces, and isolated personnel, through education, training, and equipping to plan and execute PR.”⁸²

Figure 12. PR System Preparation Function⁸³

Sound policy and doctrine are critical for PR as they provide guidance, direction, requirements and best practices, from the strategic national to the tactical levels. The evolution of PR policy and doctrine is further addressed in Chapter III.

PR education and training supports the knowledge found in policy and doctrine and is aimed at providing isolated personnel, forces and commanders and staff with the “ability to take appropriate action in a given [PR] situation based on one’s knowledge, skills, physical capability, confidence, will, and courage.”⁸⁴

PR essential equipment enhances the isolated personnel’s SERE capacity and facilitates the five PR execution tasks of report, locate, support, recover, and reintegration.⁸⁵

⁸² Ibid., I-2.

⁸³ NATO, *Allied Joint Doctrine for Recovery of Personnel*.

⁸⁴ CJCS, *Personnel Recovery*, I-3.

⁸⁵ Ibid., I-4.

Policy and doctrine, education and training, and proper equipment are aimed at providing isolated personnel, forces, and commanders and staff with the ability to perform their responsibilities and interface effectively to accomplish the five PR execution tasks of report, locate, support, recover, and reintegrate.⁸⁶

Planning Function. Joint Force Commanders (JFC) and their planners are expected to consider all available PR options when making their concept of operation (CONOP) for PR as part of their war planning.⁸⁷ Based on an analysis of how the environment influences PR operations, and how the adversary can counter any friendly PR capability, a sound military PR plan can be laid out and coordinated with any diplomatic and civilian options available.⁸⁸ Figure 13 illustrates the planning function of the PR system model.

⁸⁶ Ibid., I-4.

⁸⁷ Ibid.

⁸⁸ Ibid.

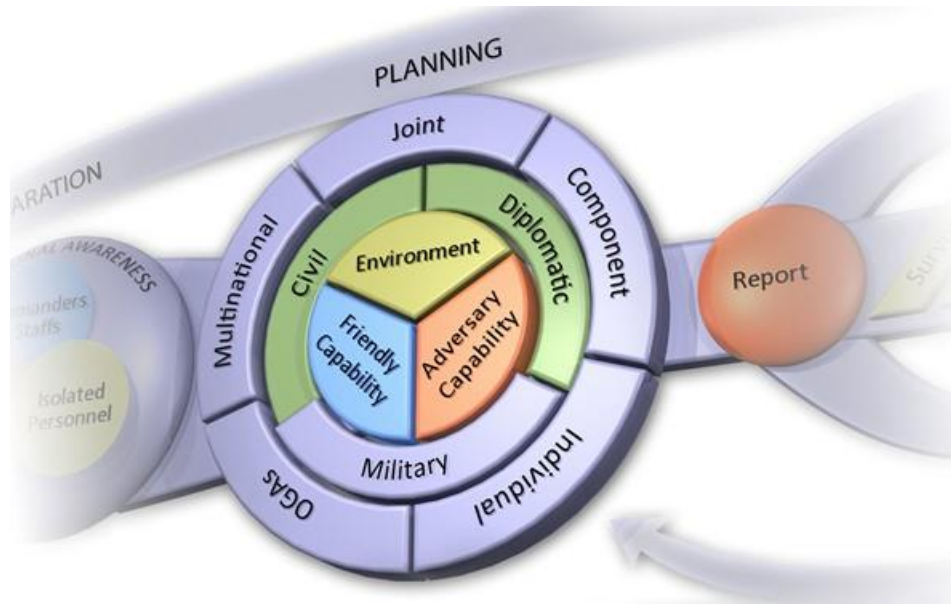

“Planning and execution consider three recovery options: diplomatic, military, and civil across all phases of operation, and then it examines the capabilities within each of those options. Within the military option, there are five categories of capabilities that can be drawn upon: the isolated individual, component, joint, multinational forces, and other government departments and agencies.”⁸⁹

Figure 13. PR System Planning Function⁹⁰

An example of a successful civil option can be found in the recovery of Black Hawk pilot CW3 Michael Durant during Operation Restore Hope (ORH) in Somalia 1993. Michael Durant was captured after he was shot down on a U.S. Special Operations mission to arrest key members of warlord Mohammed Farrah Aideed’s command structure. The International Committee of the Red Cross (ICRC) negotiated his release after the U.S. military rescue effort failed, costing 18 soldiers their lives and leaving 83 wounded in total for the whole arrest and rescue operation.⁹¹

An example of the diplomatic option can be seen in the solution to a detainee situation caused by a mid-air collision between an EP-3E maritime patrol aircraft and a Chinese fighter. The patrol aircraft was forced to make an emergency landing on China’s

⁸⁹ Ibid., I-2.

⁹⁰ NATO, *Allied Joint Doctrine for Recovery of Personnel*.

⁹¹ For the Michael Durant recovery efforts, see Bowden, *Black Hawk Down*, and Michael J. Durant, *In the Company of Heroes* (New York: G. P. Putnam’s Sons, 2003).

Hainan Island. All 24 crewmembers were detained and later released after diplomatic negotiations.⁹²

An example of the military option ranges from the capabilities of the individual to self-recover,⁹³ through the use of component, joint, multinational, or other government agencies (OGA) methods, as seen in Figure 14.

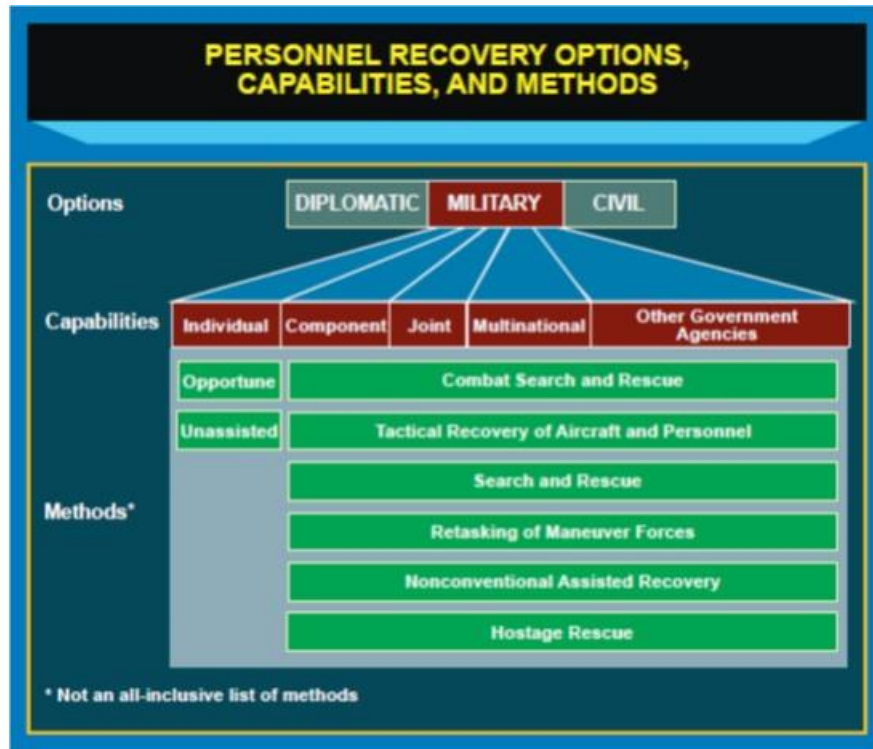

The military options available for PR range from the individual to other government agencies and encompass all service methods into one concept of PR.⁹⁴

Figure 14. PR Options, Capabilities, and Methods⁹⁵

⁹² CJCS, *Personnel Recovery*, I-4.

⁹³ For two extraordinary accounts of individual self-recovery, see Chris Ryan, *The One That Got Away* (London: Century, 1955); and Astrid Karlsen Scott and Tore Haug, *Defiant Courage: A WWII Epic of Escape and Endurance* (New York: Skyhorse, 2010).

⁹⁴ CJCS, *Personnel Recovery*, I-4.

⁹⁵ Ibid.

CSAR,⁹⁶ Tactical Recovery of Aircraft and Personnel (TRAP),⁹⁷ Search and Rescue (SAR),⁹⁸ Nonconventional Assisted Recovery (NAR),⁹⁹ Retasking of Maneuver Forces,¹⁰⁰ and Hostage Rescue (HR)¹⁰¹ all represent various methods available for PR by the different services and are encompassed by the PR system.

Execution Function. When an isolating incident takes place, isolated personnel will have to execute applicable SERE tasks and attempt to evade the enemy, facilitate rescue by properly *reporting* the incident, providing an accurate *location*, receiving and utilizing *support* given, and finally accomplishing the tasks in the *recovery* phase before being *reintegrated* to the unit and family.¹⁰²

Figures 15–20 define the five execution tasks: report, locate, support, recover, and reintegrate.

⁹⁶ For classic accounts of CSAR, see Whitcomb, *Rescue of Bat 21*; Ross W. Simpson, *Stealth Down: The Loss of the First F-117 Stealth Fighter in Combat and the Dramatic Rescue of the Pilot* (Charleston, SC: Narwhal Press, 2003); and CJCS, *Personnel Recovery*, E-1–F-6.

⁹⁷ For two successful TRAP missions conducted by the USMC, see Scott O’Grady and Michael French, *Basher Five-Two: The True Story of F-16 Fighter Pilot Captain Scott O’Grady* (New York: Bantam Doubleday Dell, 1997); and Lee Pera, Paul D. Miller, and Darrel Whitcomb, “Personnel Recovery: Strategic Importance and Impact,” *Air & Space Power Journal* (November-December 2012): 83–112. For doctrine on TRAP, see CJCS, *Personnel Recovery*, D-1–D-7.

⁹⁸ To appreciate the early development of Search and Rescue, see WWII tales of the RAF Air Sea Rescue Service in Jon Sutherland and Diane Canwell, *The RAF Air Sea Rescue Service 1918–1986* (Barnsley, England: Pen & Sword Aviation, 2005). For accounts of the United States Aerospace Rescue and Recovery Service in Vietnam, see L. B. Taylor, *That Others May Live: The Aerospace Rescue and Recovery Service* (New York: E.P. Dutton & Co, 1967).

⁹⁹ For DOD NAR, see Under Secretary of Defense for Policy, *Non-Conventional Assisted Recovery in the Department of Defense*, DoD Instruction 2310.6 (Washington, DC: Under Secretary of Defense for Policy, October 13, 2000), 20.

¹⁰⁰ See United States Army Personnel Recovery in CJCS, *Personnel Recovery*, C-1–C-9.

¹⁰¹ For examples of Hostage Rescue by JSOC, see Dilip Joseph and James Lund, *Kidnapped by the Taliban: A Story of Terror, Hope, and Rescue by Seal Team Six* (Nashville: W Publishing Group, 2014); and Richard Phillips and Stephan Talty, *A Captain’s Duty: Somali Pirates, Navy SEALs, and Dangerous Days at Sea* (New York: Hyperion, 2010). For their British counterpart, the SAS, see Will Fowler, *Certain Death in Sierra Leone: The SAS and Operation Barras 2000* (Oxford: Osprey, 2000).

¹⁰² CJCS, *Personnel Recovery*, I-8–I-9.

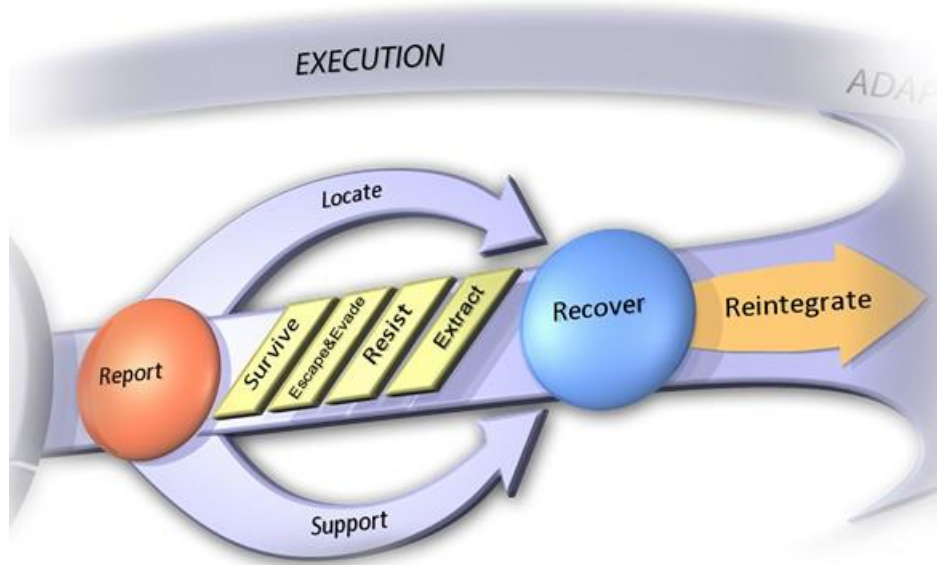

“Commanders should know the PR capabilities available to maximize unified action, achieve economy of force, and enhance situational awareness (SA) to enable those most capable of executing the five PR execution tasks: report, locate, support, recover, and reintegrate. To perform these tasks requires an organization fully networked to respond to an isolating event. The system addresses the debriefing and care of recovered personnel through the reintegration process.”¹⁰³

Figure 15. PR System Execution Function¹⁰⁴

¹⁰³ Ibid., I-2.

¹⁰⁴ NATO, *Allied Joint Doctrine for Recovery of Personnel*.

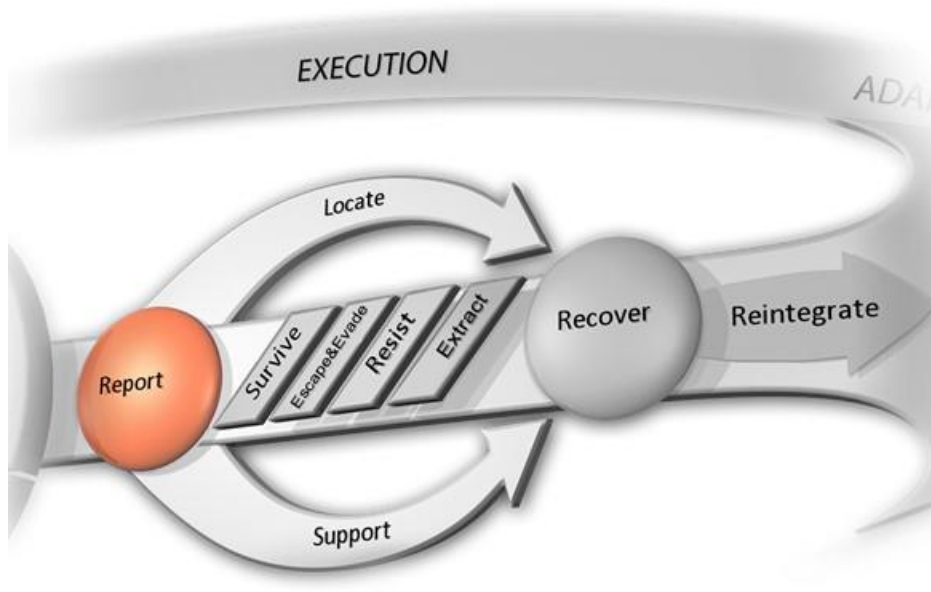

“The report task begins with the recognition of an isolation event and ends when appropriate C2 authorities are informed.”¹⁰⁵

Figure 16. PR System Report Task¹⁰⁶

¹⁰⁵ Ibid., VI-I.

¹⁰⁶ NATO, *Allied Joint Doctrine for Recovery of Personnel*.

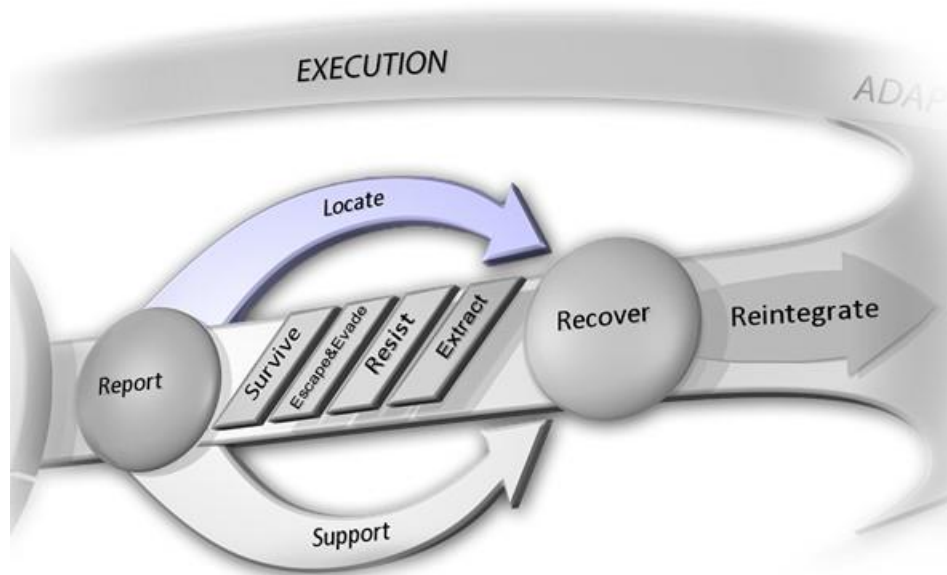

“The locate task involves the effort taken to precisely find and authenticate isolated personnel. It starts upon recognition of an isolation event and continues until the isolated person is recovered. An accurate location and positive authentication are normally required prior to committing recovery forces.”¹⁰⁷

Figure 17. PR System Locate Task¹⁰⁸

¹⁰⁷ CJCS, *Personnel Recovery*, VI-5.

¹⁰⁸ NATO, *Allied Joint Doctrine for Recovery of Personnel*.

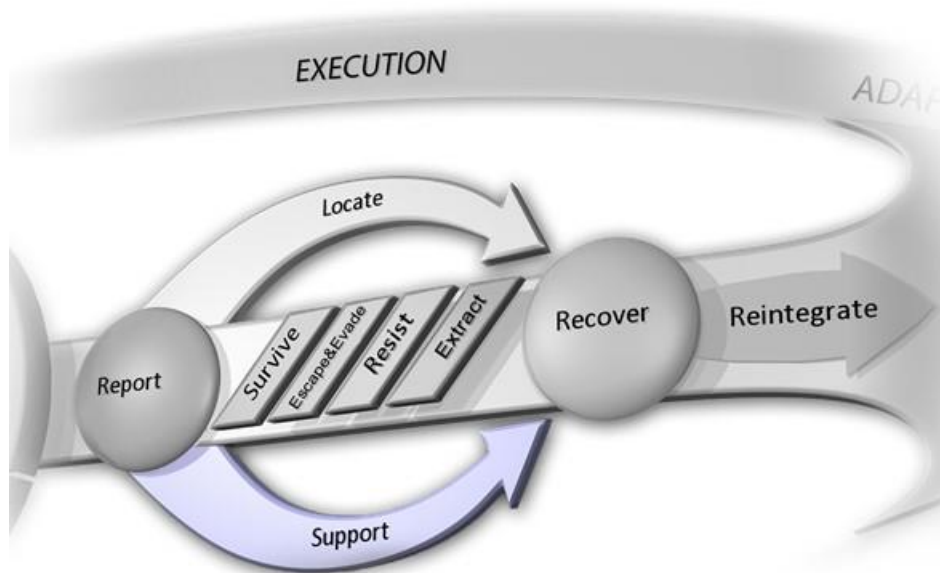

“The support task involves providing support to both the isolated person and to the isolated person’s family, with specific objectives for each. The forces used to support the isolated personnel should know the objectives and be capable of executing the TTP to achieve them. Decision makers should properly assess and mitigate risks in order to successfully execute the support task.”¹⁰⁹

Figure 18. PR System Support Task¹¹⁰

¹⁰⁹ CJCS, *Personnel Recovery*, VI-14.

¹¹⁰ NATO, *Allied Joint Doctrine for Recovery of Personnel*.

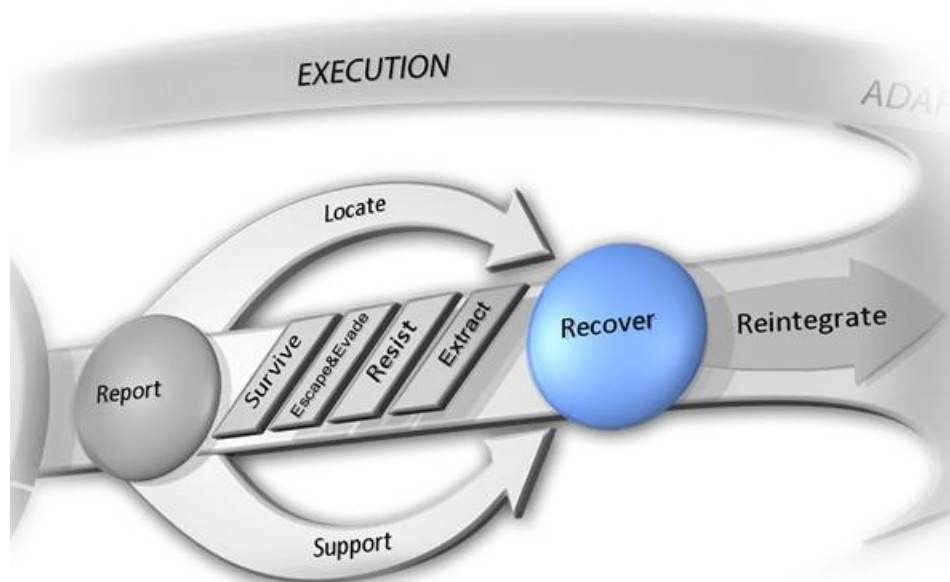

“The recover task involves the coordinated actions and efforts of commanders and staffs, forces, and isolated personnel to bring isolated personnel under the physical custody of a friendly organization. The recover task begins with the launch or redirection of forces or the engagement of diplomatic or civil processes, and ends when the recovery element hands off the formerly isolated person to the reintegration team. The recover task is accomplished through PR operation and mission planning, and individual and synergistic actions of commanders and staffs, forces, and isolated personnel. Operational flexibility and multisystem redundancy are the primary factors in successful recovery. No single recovery system, force, or organization is suitable to all situations or can meet all requirements in any given situation. To cover all contingencies, a mix of conventional and nonconventional recovery capabilities should be available for employment. Failure to establish and test multiple recovery capabilities or to adapt standardized recovery capabilities to local conditions invites failure. The decision-making process, established early during planning and preparation, will greatly assist decision makers and PR mission coordinators to launch and execute a timely and successful recovery effort.”¹¹¹

Figure 19. PR System Recover Task¹¹²

¹¹¹ CJCS, *Personnel Recovery*, VI-16–VI-17.

¹¹² NATO, *Allied Joint Doctrine for Recovery of Personnel*.

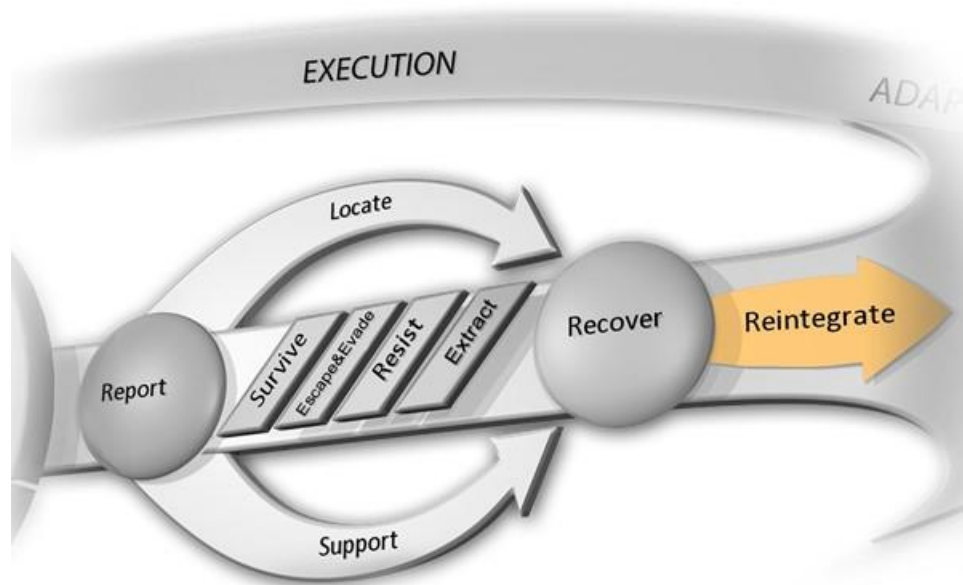

“Reintegrate is a critical task that allows DOD to gather necessary intelligence and SERE information while coordinating multiple activities and protecting the health and well-being of returned isolated personnel. In their planning, CCDRs establish a reintegration process, to include locations, teams, and responsibilities. The reintegration process should also be included in combatant command PR directives. Two key components of this process are qualified SERE and intelligence debriefers who gather information from recovered isolated personnel and SERE psychologists and others who assist the recovered isolated personnel to decompress and reintegrate to their unit, family, and society.”¹¹³

Figure 20. PR System Reintegrate Task¹¹⁴

¹¹³ CJCS, *Personnel Recovery*, VI-29

¹¹⁴ NATO, *Allied Joint Doctrine for Recovery of Personnel*.

a. Isolated Personnel SERE Skills

An isolated person's ability to perform SERE skills is essential in the execution phase as it complements the five execution tasks. The isolated personnel must be able to survive the environment, the threat, and the theater.¹¹⁵

Surviving the *environment* includes basic land and maritime survival and the use of survival equipment. To survive the *threat* means that the isolated personnel must be able to evade a hostile force, survive in captivity as a POW or as a hostage if captured, resist exploitation, including interrogation, escape captivity if possible and prepare for extraction by recovery forces.¹¹⁶ To survive the *theater* includes specific theater training based on the area of operation that includes understanding of the geography, cultural aspects, topography and climate, and the motives and modus operandi of hostile elements that may force captivity on individuals.¹¹⁷

The level of SERE training the isolated personnel receive depends on their risk of capture and ranges from only theoretical training, labeled SERE level-A; a combination of theoretical and practical training, labeled SERE level-B; to the advanced level-C that includes the SERE-A and B-level training in a realistic field exercise simulating the combat environment in which personnel are likely to find themselves. These SERE training levels also require constant updating to include theater specific, pre-deployment training.

The Adaptation Function and Risk Mitigation. The last element of the PR system is the mitigation of risk. It speaks to future PR preparation, planning, and execution functions and the need to make the necessary changes as seen in Figure 21.¹¹⁸

¹¹⁵ SERE “defines the set of tactics, techniques, and procedures that will give Isolated Personnel the tools to survive in any environment and to evade capture where such a threat exists. Failing that, to resist exploitation by captors and, if the situation permits, escape captivity to finally support their own or assisted recovery and return with dignity.” NATO, *NATO Survival, Evasion, Resistance and Extraction (SERE) Training*, 2.

¹¹⁶ NATO, *NATO Survival, Evasion, Resistance and Extraction (SERE) Training*, 4.

¹¹⁷ *Ibid.*, 4.

¹¹⁸ CJCS, *Personnel Recovery*, I-10.



“The entire system continually improves and learns from its mistakes and successes through adaptation.”¹¹⁹

Figure 21. PR System Adaptation Function¹²⁰

The PR system is visualized as a linear model, but as JP 3-50 states, the four functions can all happen at once or in any sequence.

Although the functions are presented in the apparent sequential order of preparation, planning, execution, and adaptation, it is important to understand that these functions can occur simultaneously or in any sequence. The PR system is iterative and the individual activities are interdependent; a change occurring in one function can affect what is happening in the other three. The functions are not discrete steps, but rather activities that continuously interact with one another and adjust or adapt to maintain a relevant and effective system.¹²¹

2. The History of Personnel Recovery

This section on the historical perspective and development of PR from early ideas and efforts is limited to the span from the beginning of WWII and until the present day, including the Global War on Terrorism (GWOT). The historical review revealed insights on how PR as an idea has developed, been retained, or forgotten, and how military innovations in technology have influenced PR doctrine and organizations.

¹¹⁹ Ibid., I-2.

¹²⁰ NATO, *Allied Joint Doctrine for Recovery of Personnel*.

¹²¹ CJCS, *Personnel Recovery*, I-2.

a. WWII

Escape and Evasion (E&E) did not originate in WWII, but the technological innovation of the airplane used by the Allies during WWII resulted in high numbers of aircrews downed behind enemy lines. SOF and agents of the SOE¹²² and the Office of Strategic Services (OSS)¹²³ were also inserted behind enemy lines and shared a common interest in being able to escape and evade if needed. As a result of their missions behind enemy lines, both SOF and aircrews since have had the incentive to develop a PR capability and both have been the predominant users of it.

Even if isolated personnel have been forced to escape and evade through all military history, WWII generated a formidable rise in numbers of isolated personnel behind enemy lines. The consequence of this rise in numbers was unprecedented innovation regarding PR covering doctrine,¹²⁴ organization,¹²⁵ and technology.¹²⁶ Two secret organizations were created to prepare personnel for escape and evasion and to organize escape networks: the British MI9 and the American MIS-X.¹²⁷ Additional Air Sea Rescue units¹²⁸ performed critical over-water rescues of Allied pilots in the English Channel, the Mediterranean Ocean, and the American areas of operation in the Pacific

¹²² M. R. D. Foot, *SOE in France: An Account of the Work of the British Special Operations Executive in France 1940–1944* (London: HSMO, 1966).

¹²³ Gregory A. Freeman, *The Forgotten 500: The Untold Story of the Men Who Risked All for the Greatest Rescue Mission of World War II* (New York: NAL Calibel, 2007)

¹²⁴ For examples of doctrines, see Department of the Air Force, *Survival*, AFM 64-5 (Washington, DC: Air Training Command, 1945); War and Navy Departments, *A Pocket Guide to Netherlands East Indies* (Washington, DC: Government Printing Office, 1944); War Department, *Norwegian: A Guide to the Spoken Language*, TM 30-310 (Washington, DC: U.S. Government Printing Office, 1943); and War Department, *Norwegian Phrase Book*, TM 30-610 (Washington, DC: U.S. Government Printing Office, 1943).

¹²⁵ For the organization and development of MI9, see War Office, *Attachment "A": Historical Record of MI9* (London: General Staff, 1945). For MIS-X, see Lloyd R. Shoemaker, *The Escape Factory: The Story of MIS-X, The Super-Secret U.S. Agency Behind World War II's Greatest Escapes* (New York: St. Martin's Press, 1990).

¹²⁶ For an in-depth account of the innovation of Escape and Evasion tools, see Clayton Hutton, *Official Secret: The Remarkable Story of Escape Aids—Their Invention, Production—and the Sequel* (New York: Crown, 1961); and Clayton Hutton, *Per Ardua Libertas* (London: War Office, 1942).

¹²⁷ Airey Neave, *Saturday at MI9: The Classic Account of the World War Two Allied Escape Organisation* (Barnsley, England: Leo Cooper, 2004); Shoemaker, *Escape Factory*.

¹²⁸ See L. Douglas Keeney, *Air-Sea Rescue 1941–1952* (Campbell: Premiere, 2013); and Norman Franks, *Another Kind of Courage: Stories of the UK-Based Walrus Air-Sea Rescue Squadrons* (London: Patrick Stephens, 1994).

Ocean. The aim of MI9 and MIS-X was to “educate and train” high risk personnel in the art of survival, escape, and evasion and “conduct after capture.”¹²⁹ The head of MI9 also believed that the pain and suffering of POWs and evaders would be lessened by the knowledge that there were a distant staff that cared intensely about them and worked hard for their cause.¹³⁰

Thanks to feedback from returning survivors, innovations in equipment to survive a shoot down included the use of parachutes,¹³¹ flotation devices to prevent drowning, and survival tools for all climates and situations. Aircrew survivors of isolating events created official and unofficial clubs to recognize the success of their struggles and boost morale for the rest of the flying force.¹³² Early efforts of “reintegration” were conducted through the medical treatment of pilots with severe burns, called “Guinea pigs.”¹³³ MI9 also conducted extensive E&E debriefing of returning aircrew who had escaped from behind enemy lines and integrated their knowledge in future aircrew “SERE” briefings.¹³⁴

At the end of the war, the official account of MI9 estimates the total numbers of people returning to friendly lines by the effort of the networks to be a total of 35,190.¹³⁵ The importance of having a competent PR organization led by highly qualified commanders and the staff is emphasized, and a PR organization to back them up is highlighted by the authors of *MI9 Escape and Evasion 1939–1945*.

¹²⁹ For the MI9 training course, see War Office, *Enclosure II, Historical Record of RAF Intelligence Course “B”* (London: General Staff, 1945). For MI9 debriefs of escapers and evaders that provided the lessons learned for the “B” course, see War Office, *MI9 Evasion Reports* (London: General Staff, 1945).

¹³⁰ Neave, *Saturday at MI9*, 28.

¹³¹ For the development of the parachute, see John A. Neal, *Bless You, Brother Irvin: The Caterpillar Club Story* (Ontario: General Store, 2005).

¹³² Colin Pateman, *Goldfish, Caterpillar & Guinea Pigs: Accounts of Pilots and Air Crews from the Second World War* (Oxford: Fonthill Media, 2012).

¹³³ See Edward Bishop, *The Guinea Pig Club* (London: Macmillan & Co, 1963); Edward Bishop, *McIndoe’s Army: The Story of the Guinea Pig Club and Its Indomitable Members* (London: Grub Street, 2001); and E. R. Mayhew, *The Reconstruction of Warriors* (London: Greenhill Books, 2004).

¹³⁴ For the primary doctrine on escape and evasion, see War Office, *MI9 Bulletin*, Copy 703 (London: General Staff, 1945). For lessons learned that were turned into Escape and Evasion briefings, see War Office, *Enclosure II*. For the background evasion debriefing reports, see War Office, *MI9 Evasion Reports*.

¹³⁵ Neave, *Saturday at MI9*, 315.

Anyone who has to embark on such an adventure will be lucky if he has a staff to back him in secret that is in hands a tenth as capable as Norman Crockatt's.¹³⁶

Our greatest debt, which we owe jointly with the rest of the free world, is almost too large to fit into print. It is owed not only to those who attempted escapes and evasion, and thus made the Axis powers' attempt to control the world more troublesome to the Axis; but also to those uncounted thousands of people, ordinary in appearance, extraordinary in courage and devotion, who made the work of the escape networks feasible. They were of many nationalities, of all ages; of both sexes, of all classes; rich and poor, learned and plain, Christian and Jew, Marxist and mystic. Without the work they did, for which a large proportion of them paid with their lives, the world today would be a meaner place, and we write this book lest they be quite forgotten.¹³⁷

The high number of people in need of PR during WWII led to a rapid advance in technology, organization, and PR doctrine to assist the reintegration to friendly forces and to mitigate the risk of PR operations. To prepare the allied forces for PR, policy was put in place to direct the establishment of MI9 and MIS-X to secretly educate and train high-risk personnel in the art of Escape and Evasion. Both UK and US Air Sea Rescue units were increased in numbers, and improved doctrine for their use was developed. MI9 initially educated and trained most aircrew, commandos, and SOE agents on E&E topics, but the increased need for briefings and numbers of people that required their training led to the development of the MI9 "B-Course" to expand local instructor capability.¹³⁸ Both equipment needed for pure survival in the different climates of the world and escape and evasion aids were continuously developed. The planning for recovery of own personnel increased and led to pre-staging of rescue units and development of escape networks in France. The execution of recovery options was primarily done by the Air Sea Rescue units and the different escape and evasion networks. A few evaders were also evacuated by the same airplanes that inserted SOE agents into France, by the SOE "Shetlands Bus" operating in and out of Norway, and by rescue operations conducted by OSS nits like the Long Range Desert Group (LRDG). Numerous people also managed to survive, escape,

¹³⁶ Ibid., 308.

¹³⁷ Ibid., 11–12.

¹³⁸ See War Office, *Enclosure II*.

and evade back to friendly lines on their own. MI9 and MIS-X debriefings of thousands of rescued personnel made it possible for planners to adapt continuously and improve the PR efforts of preparation, planning, and execution of PR operations.¹³⁹ To sum it up, the United States began WWII with hardly any PR capability and ended the war with a robust and dedicated capability in the Navy rescue squadrons and the Army Air Force emergency rescue squadrons. After the war, the same capabilities disappeared under massive cutbacks, and the combat part of rescue was deleted from the ERS portfolio as the nuclear scenarios that quickly developed did not leave any room for combat rescue.¹⁴⁰

¹³⁹ The total literature from WWII covering Personnel Recovery efforts is enormous, due to the experience of so many people involved and their written accounts describing different perspectives. The following literature has been chosen to illustrate the main efforts covering all aspects of the PR from preparation to adaptation.

For the best accounts of the responsible organizations of PR, see the following books: M. R. D. Foot, and J. M. Langley, *MI9 Escape and Evasion 1939–1945* (London: The Bodley Head, 1979); Shoemaker, *Escape Factory*; Keeney, *Air-Sea Rescue 1941–1952*; Sutherland and Canwell, *RAF Air Sea Rescue Service 1918–1986*.

For an overview of Escape and Evasion networks, see Vincent Brome, *The Way Back: The Story of Lieut.-Commander Pat O’Leary G.C., D.S.O., R.N.* (London: Casel and Company Ltd., 1957); Reanne Hemingway-Douglas and Don Douglas, *The Shelbourne Escape Line: Secret Rescues of Allied Aviators by the French Underground, the British Royal Navy and London’s MI9* (Anacortes, WA: Cave Art Press, 2014); Neave, *Little Cyclone*; Lucien Dumais, *The Man Who Went Back* (London: Leo Cooper, 1975); and David Howarth, *The Shetland Bus: A WWII Epic of Escape, Survival, and Adventure* (Guilford: The Lyon Press, 2001).

To appreciate the individual escape and evaders’ perspectives, see Graham Pitchfork, *Shot Down and in the Drink: True Stories of RAF and Commonwealth Aircrews Saved From the Sea in WWII* (Richmond: The National Archives, 2005); Philip D. Caine, *Aircraft Down!: Evading Capture in WWII Europe* (Washington: Brassey’s, 1997); and Scott and Haug, *Defiant Courage*.

For rescue by Commandos, SOE, and OSS, see Cate Lineberry, *The Secret Rescue: An Untold Story of American Nurses and Medics behind Nazi Lines* (New York: Little, Brown and Company, 2013); Freeman, *Forgotten 500*; Hugh Verity, *We Landed by Moonlight: Secret RAF Landings in France, 1940–1944* (Wimslow, England: AirData, 1995); and Gordon L. Rottman, *The Los Banos Prison Camp Raid: The Phillipines 1945* (Oxford: Osprey, 2010).

For the experience of captivity and interrogation, the following books are recommended: Raymond F. Toliver, *The Interrogator: The Story of Hanns Scharff, Luftwaffe’s Master Interrogator* (Fallbrook, CA: Aero Publishers, Inc., 1978); and Jon Couch, *Caged Heroes: American POW Experiences from the Revolutionary War to the Present* (Bloomington, IN: AuthorHouse, 2011).

For escape and evasion aid development, see Hutton, *Official Secret*; and R. E. Baldwin and Thomas McGarry, *Last Hope: The Blood Chit Story* (Atglen, PA: Schiffer, 1997). For examples of debriefing reports and their resulting new recommendations to future escapers, see War Office, *MI9 Evasion Reports*; and War Office, *MI9 Bulletin*.

¹⁴⁰ Georg Galdorisi and Tom Phillips, *Leave No Man Behind: The Saga of Combat Search and Rescue* (Minneapolis: Zenith Press, 2008), 524

b. End of WWII to Korea and Vietnam

After the war, MI9 was succeeded by an interservice that had both an intelligence capacity and a rescue capability in the Intelligence Corps and the Special Air Service (SAS).¹⁴¹ The United States MIS-X was disbanded, and the OSS developed into the current Central Intelligence Agency (CIA) and led to the initial Special Forces Groups (SFG).¹⁴²

In addition to the Air Sea Rescue capability already developed by the Allies in WWII, the need for an overland capability became apparent. The introduction of the new technology of the helicopter became the option to rescue personnel behind enemy lines. When the Korean War broke out, the helicopter became a crucial tool in the PR game. Still limited to daytime rescues, all services deployed and improved their tactics, techniques, and procedures through hard lessons learned during the Korean War. Despite the heavy losses, the USMC, USN, and the USAF conducted a total of 737 rescues, 203 which were behind enemy lines, 282 from disputed waters, and 252 “benign” rescues.¹⁴³

Lessons learned from these events stressed the importance of proper reporting of an incident, accurately locating the survivors, and the need for fixed-wing aircraft Rescue Combat Air Patrol (RESCAP) to support and protect the vulnerable helicopters. The need for appropriate authenticating of downed aircrew led to the development of individual authentication procedures. The lessons learned in Korea would unfortunately be relearned in the next major conflict in Southeast Asia. The Korean War did, however, result in more robust and dedicated rescue capability and CSAR development during the U.S. engagement from 1961–1975.¹⁴⁴

The Vietnam War resulted in vastly improved joint command and control over the rescue efforts and standardization of tactics, techniques, and procedures (TTPs) and

¹⁴¹ Neave, *Saturday at MI9*, 307

¹⁴² Thomas K. Adams, *U.S. Special Operations Forces in Action: The Challenge of Unconventional Warfare* (London: Frank Cass, 1998), 57–77

¹⁴³ *Ibid.*, 206.

¹⁴⁴ For well researched Search and Rescue history of the Korean war and the war in Southeast Asia, consult Earl H. Tilford, *The United States Air Force: Search and Rescue in Southeast Asia* (Washington, DC: Center for Air Force History, 1992); and Galdorisi and Phillips, *Leave No Man Behind*.

communications between survivors and rescue forces. In January 1966, the Air Rescue Service became the Aerospace Rescue and Recovery Group (ARRG)¹⁴⁵ and was a significant organizational change to improve joint rescue efforts. In the summer of 1967, several fundamental changes would shape combat rescue: improved protection of helicopters by outfitting them with machine guns; in-flight refueling capability; and the arrival of the HH-53 helicopter.¹⁴⁶ For a thorough understanding of the PR capability evolution, the rescues of “Bat 21” and “Streetcar 304” can serve as two examples. “Bat 21” was shot down during a massive North Vietnamese offensive, and the following 12 days of rescue efforts and sacrifice by the involved forces paint a vivid picture of the efforts of all actors. “Streetcar 304” was a 40 hour long rescue where the Air Force flew 189 sorties to rescue a Navy A-7 pilot.¹⁴⁷ At the end of the Vietnam War, as the Joint Search and Rescue Center (JSRC) closed in 1975, more than two-thirds of the 4,120 isolated personnel had been rescued.¹⁴⁸

c. Desert Storm 1991

During Operation Desert Storm, the majority of rescue missions were performed by SOF since the Aerospace Rescue and Recovery Service (ARRS) was not yet ready for the wartime mission of CSAR.¹⁴⁹ SOF forces had better training equipment and readiness as a result of the lessons learned from Operation Eagle Claw. SOF did not have the CSAR mission as a primary mission, but they were the ones providing the best capability and the best option for the Joint Force Commander (JFC). During the 43-day short war, the USAF Central Command (USCENTAF) Joint Rescue Coordination Center (JRCC)

¹⁴⁵ Galdorisi and Phillips, *Leave No Man Behind*, 234.

¹⁴⁶ *Ibid.*, 328.

¹⁴⁷ See William C. Anderson, *Bat-21* (Englewood Cliffs, NJ: Prentice-Hall, 1980); Kenny Wayne Fields, *The Rescue of Streetcar 304: A Navy Pilot's Forty Hours on the Run in Laos* (Annapolis, MD: Naval Institute Press, 2007); George J. Marrett, *Cheating Death: Combat Air Rescues in Vietnam and Laos* (New York: Smithsonian Books, 2006); Mike Jackson, and Tara Dixon-Engel, *Naked in Da Nang: A Forward Air Controller in Vietnam* (St. Paul, MN: Zenith Press, 2004); Dave Richardson, *Vietnam Air Rescues* (San Bernadino, CA: Dave Richardson, 2010); George J. Veith, *Code Name Bright Light: The Untold Story of U.S. POW Rescue Efforts during the Vietnam War* (New York: The Free Press, 1998); and Whitcomb, *Rescue of BAT 21*.

¹⁴⁸ Thomas R. Dorl, “Personnel Recovery and the DOTMLPF Changes Needed for the Twenty-First Century” (master’s thesis, Joint Advanced Warfighting School, 2005), 14.

¹⁴⁹ *Ibid.*, 16.

log shows 20 missions attempted. Overall, the coalition lost 43 aircraft and 87 crewmembers (49 were killed, 38 survived the shootdown, eight were rescued, and 38 became POWs).¹⁵⁰ Of those who became POWs, an analysis shows that eight of those were rescuable and did not face immediate capture by Saddam Hussein's ground forces.¹⁵¹ In his book *Combat Search and Rescue in Desert Storm*, Darrel D. Whitcomb provides an in-depth analysis of the conflict and provides the following concluding highlights.¹⁵² First, the area of operations was challenging for CSAR as it was barren with no place to hide, isolated personnel faced a hostile population, and enemy air defenses were lethal. Second, the best CSAR strategy is still not to be shot down. Third, the Air Force CSAR capability was low; its CSAR helicopters, the HH-53, were transferred to SOF, and the remaining HH-3 were not suitable for the high threat area. Fourth, CSAR expectations were high among aircrews based on the history from Vietnam. Fifth, the failed rescue of an F-15E crew early on took a toll on morale within the F-15 E community. Sixth, the capability for accurately locating and discreetly talking to downed aircrew was lacking. Despite the difficulties, SOF conducted numerous joint CSAR missions, as well as SAR. SOF aircraft were never "not available." Leaving CENTAF responsible for CSAR without control over necessary rescue assets violated unity of command.¹⁵³

Overall, Operation Desert Storm highlighted the fact that PR is a joint mission and that, in a denied area, the importance of a precise location of isolated personnel is crucial. GPS systems were just becoming available but not all had access, and the Air Force still had the old handheld PRC-90 radios with two fixed international known frequencies.¹⁵⁴ In their chronicle of nearly 100 years of rescues, Galdorisi and Phillips highlight the status of CSAR in Desert Storm. "Doctrine was theoretically solid, and technology was blooming, but the rescue structure just was not there to properly support

¹⁵⁰ Darrel D. Whitcomb, *Combat Search and Rescue in Desert Storm* (Montgomery, AL: Air University Press, 2006), 258.

¹⁵¹ *Ibid.*, 261.

¹⁵² *Ibid.*, xvi–xviii.

¹⁵³ *Ibid.*

¹⁵⁴ Galdorisi and Phillips, *Leave No Man Behind*, 500.

the commanders in executing the doctrine with aggressive but practical audacity. More rescues could have happened within acceptable risk to rescue personnel.”¹⁵⁵

In 2008, Galdorisi and Phillips summed up their chronicle of CSAR history with the following statement and questions:

The United States now seems to be confronted with an entirely new situation where the importance of one prisoner as a propaganda pawn outweighs the sum of prisoners from previous wars. ... Now, any one prisoner, military or civilian, can be that dreaded publicity nightmare, beheaded by hooded fanatics bereft of humanity. ... In the GWOT, can America any more suffer the loss of even one potential rescuable, isolated person killed and hung from a bridge or dragged through the streets, or captured because rescuers can't get them in time? ... From the traditional and honored justification for CSAR because of the worth of men, the argument has transitioned to the increasing importance of a single man, military or civilian, in the unnatural barbarity the world now faces. Dare we leave even one man behind?¹⁵⁶

3. The Strategic Impact of Personnel Recovery

PR is not only important to the most obvious stakeholder, the isolated personnel with friends and family, but tactical PR events can quickly become a matter of strategic importance and national interest. One historical example is the importance of rescuing enough fighter pilots from the English Channel that they could continue the Battle of Britain during a critical phase of WWII. Another examples is the potential political and social effects of the current fight against ISIS who, by burning a Jordanian pilot to death and by spreading their well-rehearsed propaganda video of this gruesome act on global social networks, can create fear among participating coalition nations, while at the same time boosting their own recruitment of foreign fighters to their cause.

Archival records illustrates the strategic importance of PR. This section highlights two themes that support this notion. First, failed United States strategic PR events have led to the development of highly capable military units like the Joint Special Operations Command, USSOCOM, and similar international units as tools for a nation's strategic

¹⁵⁵ Ibid., 500–1.

¹⁵⁶ Ibid., 527.

leadership. Such units have been proven to have valuable response capabilities for recovering isolated personnel in peacetime, crisis, and war. Second, the enemy often has tried to influence the will of an opponent by exploiting captured personnel as propaganda, using human shields on important targets, exploiting hostages in negotiations, and threatening severe harm or death to anyone captured.

The Son Tay raid, the Mayaguez incident, and Operation Eagle Claw, pictured in Figure 22, highlight the strategic impact of PR and the stakes involved for national leadership.



Figure 22. The Strategic Impact of PR¹⁵⁷

a. The Son Tay Raid

Approved by President Nixon, and executed on November 20–21, 1970, by U.S. special operators from the Army Green Berets and Air Force Special Operations, the operation aimed to rescue about 70 POWs inside Son Tay prison close to Hanoi, Vietnam.¹⁵⁸ The camp was located in the most heavily defended area of the country and required meticulous planning and precise execution. The operators had prepared and

¹⁵⁷ Figure composed of covers from John Gargus, *The Son Tay Raid: American POWs in Vietnam Were Not Forgotten* (College Station, TX: Texas A&M University Press, 2007); and *Time* magazine covers from May 26, 1975; November 10, 1980; and May 5, 1980.

¹⁵⁸ John T. Carney and Benjamin F. Schemmer, *U.S. Special Operations Forces* (Tampa, FL: Hugh Lauter Levin Associates, 2003), 124–27. For a detailed account of the mission, see Gargus, *Son Tay Raid*; and Benjamin F. Schemmer, *The Raid: The Son Tay Prison Rescue Mission* (New York: Ballantine, 1976).

rehearsed the mission more than 170 times. Although flawlessly executed, the mission was too late. The POWs had been moved, although when they learned about the attempt, they found great strength and support in the effort, as they understood their government had not forgotten them. Because of the raid, North Vietnamese shifted from keeping POWs in camps scattered all over the country to keeping most of the POWs in the Hanoi Hoa Lo Prison, which did have an advantage:

Occupants for the first time consequently could converse, care for each other, hold church services, and occupy endless hours with educational classes that included math, foreign languages, even culinary arts. Those improvements immeasurably boosted morale and, in some cases, preserved sanity until freedom finally arrived two years later.¹⁵⁹

The Son Tay raid had a strategic effect even though it failed in its immediate goal of rescuing the POWs, as the efforts and capability displayed in the attempt sent a strategic message:

The raid received well-deserved publicity. The world learned that American soldiers were not pushovers—they continued to resist their captors in spite of inhumane treatment and torture. It also served notice to those who would hold U.S. soldiers in captivity in future conflicts that they could not dismiss the likelihood of a daring rescue of American prisoner by their dedicated comrades.¹⁶⁰

b. The Mayaguez Incident

The Mayaguez incident at the very end of the Vietnam War further illustrates the challenges of command and control and the need to act on a short notice. It started with the seizure of an American merchant vessel, the *Mayaguez*, off the Cambodian coast by the Khmer Rouge. President Gerald Ford ordered military intervention, and within three days the crew were recovered, but not without loss of life to the rescue forces.¹⁶¹ The quick response to the incident was most likely influenced by the 1969 North Korean capture of the Navy Intelligence ship *USS Pueblo*, which was a humiliating experience

¹⁵⁹ Carney and Schemmer, *U.S. Special Operations Forces*, 127.

¹⁶⁰ Gargus, *Son Tay Raid*, 264–65.

¹⁶¹ John F. Guilmartin, *A Very Short War: The Mayaguez and the Battle of Koh Tang* (College Station, TX: Texas A&M University Press, 1995), 3.

for the United States.¹⁶² It took 11 months of negotiation, a U.S. expression of “regret” for the *Pueblo*’s activities, and the ship’s seizure when the crew was released.¹⁶³ To prevent a new Pueblo incident, both the administration and President Ford felt a great need to act in the Mayaguez incident.¹⁶⁴

A short time after the *Mayaguez* was captured, the U.S. Air Force sank Khmer Rouge patrol boats in the Gulf of Siam, and U.S. Marines invaded Cambodian territory with a beachhead on the island of Koh-Tang. The Marines engaged in a 14-hour-long battle before disengaging. Other Marines boarded and recaptured the *Mayaguez*, while the Navy bombed targets on the mainland of Cambodia.¹⁶⁵ What made this operation different from previous operations was the new technology of worldwide communication that enabled national leaders to have immediate control of military forces globally.¹⁶⁶ “This capability, coupled with sophisticated methods of technical intelligence gathering and analysis (made) possible the precise management of military forces under tight control from the top.”¹⁶⁷ As Guilmartin highlights, however, this capability is a double-edged sword as “no amount of communication can replace a competent and responsible commander on scene.”¹⁶⁸ The tactical fiasco reduced the strategic merits of the operation.¹⁶⁹ The recovery of the ship’s crew “obscured the fact that eighteen Americans died landing at the wrong location to rescue prisoners the Cambodians had already decided to free.”¹⁷⁰ Guilmartin makes a point of the inability to learn from the event and states:

In fact, serious errors were made within the military command structure, but no service had a monopoly on them, and there was plenty of embarrassment to go around. The net result was silence, which is

¹⁶² Lucien S. Vandenbroucke, *Perilous Option: Special Operations as an Instrument of U.S. Foreign Policy* (New York: Oxford University Press, 1993), 75.

¹⁶³ *Ibid.*

¹⁶⁴ *Ibid.*

¹⁶⁵ Guilmartin, *A Very Short War*, 27.

¹⁶⁶ *Ibid.*, 29.

¹⁶⁷ *Ibid.*

¹⁶⁸ *Ibid.*, 157.

¹⁶⁹ Vandenbroucke, *Perilous Option*, 113.

¹⁷⁰ *Ibid.*, 152.

unfortunate because there was a great deal to be learned from these operations.¹⁷¹

To sum it up, the national leadership was in a hurry to resolve the incident. Lured by the technology that enabled detailed command and control of the involved forces, they rushed to solve the problem without a joint force that could keep up with the speed of the operation, which resulted in loss of life. Vice Admiral Steele commented on the price of such haste: “I just feel those men died in vain. ... It was just a terrible rush to get it done.”¹⁷²

c. Operation Eagle Claw

The command and control challenges that interservice units experienced in the Mayaguez incident surfaced in the next strategic PR event in April 1980. The Iranian hostage taking of the U.S. embassy personnel in Iran and the following rescue attempt ended in a desert debacle with a smoking wreckage and an aborted mission. Even with the highly trained Delta Force as the ground assault force, the operation demanded a true interservice trained force. The interservice training had been superficial and as the operation launched, they quickly ran short of assets, as several helicopters had to abort en route. When eight men died in a crash between a hovering helicopter and a C-130 at the first staging area, Desert One, the failure was complete.¹⁷³

Lucien S. Vandenbroucke summarizes the Son Tay raid, the Mayaguez incident, and Operation Eagle Claw and concludes that:

Recurrent problems have plagued U.S. strategic special operations. Faulty intelligence, poor interagency and interservice cooperation and coordination, provisions of inadequate advice to decision makers, wishful thinking, and overcontrol of mission execution by officials far removed

¹⁷¹ Guilmartin, *A Very Short War*, 5..

¹⁷² Vandenbroucke, *Perilous Option*, 113.

¹⁷³ Carney and Schemmer, *U.S. Special Operations Forces*, 134–35. For the ground commander’s perspective, see James H. Kyle and John Robert Eidson, *The Guts to Try: The Untold Story of the Iran Hostage Rescue Mission By the On-Scene Desert Commander* (New York: Orion Books, 1990). For a detailed analysis of the mission, see Vandenbroucke, *Perilous Option*, 114–52.

from the theatre of operations have repeatedly jeopardized the ability of the United States to conduct such missions successfully.¹⁷⁴

For President Carter, the failure was a military, diplomatic, and political fiasco, and his national approval ratings dropped from 75 percent to 20 percent during the hostage ordeal.¹⁷⁵

The series of events and their failures were two major reasons why JSOC and USSOCOM would rise out of the ashes of Desert One.¹⁷⁶ The debacle in the desert would be a “defining moment for the American people and Special Operations.”¹⁷⁷ As General Sam Wilson states, “That crushing failure at Desert One and its consequences told everyone, despite the enormous talent we had, we hadn’t put it together right and something had to be done.”¹⁷⁸

In addition to Desert One, the invasion of Grenada highlighted the need for SOF service components to talk to each other as a joint force. As a result of a long and hard process and the work done by senators William Cohen and Sam Nunn as the driving forces in the legislature, the “U.S. Special Operations Command was formed April 16, 1987, with special responsibility to organize, train, and equip U.S. SOF from the Army, Navy, and Air Force.”¹⁷⁹

NATO nations have also developed similar hostage rescue units to respond rapidly to PR incidents, with units like the German Grenzschutzgruppe 9 (GSG-9),¹⁸⁰ British SAS,¹⁸¹ and the Norwegian FSK for the most difficult or political sensitive missions.

¹⁷⁴ Vandenbroucke, *Perilous Option*, 152.

¹⁷⁵ Pera, Miller, and Whitcomb, “Personnel Recovery,” 96.

¹⁷⁶ Mike Bottoms, “USSOCOM Celebrates Its 20th Anniversary,” *Tip of the Spear* (April 2007): 4.

¹⁷⁷ *Ibid.*, 4.

¹⁷⁸ Lt Gen Sam Wilson, in Bottoms, “USSOCOM Celebrates Its 20th Anniversary,” 4.

¹⁷⁹ *Ibid.*, 5.

¹⁸⁰ Chris McNab, *Storming Flight 181: GSG-9 and the Mogadishu Hijack 1977* (Oxford: Osprey, 2011).

¹⁸¹ Gregory Fremont-Barnes, *Who Dares Wins: The SAS and the Iranian Embassy Siege 1980* (Oxford: Osprey, 2009)

A country's capability to rescue its own personnel and prevent exploitation by the enemy have been important in every major operation. Successful recoveries have boosted morale as successful rescues like "Basher-52,"¹⁸² "Hammer-34," and "Vega-31"¹⁸³ in the Balkans during the 1990s. If they had failed, one could have experienced strategic political effects like the ones created by the Black Hawk Down incident in Somalia 1993.¹⁸⁴ Figure 23 depicts news accounts of several of these personnel recovery attempts.



From left to right, British Tornado pilot POW displayed on television by Saddam Hussein during Desert Storm 1991; Mike Durant, the captured pilot of the Black Hawk Down incident in 1993; Scott O'Grady after his rescue by the USMC; Jessica Lynch after the JSOC rescue; and the ISIS magazine *Dabiq* that featured the graphic display of the burning of the captured Jordanian pilot in Syria.

Figure 23. PR Propaganda¹⁸⁵

In sum, the stakeholders in PR are diverse and range from the tactical, the IP and his family colleagues and friends, to the strategic national leadership and society. PR events have the potential to influence a nation's will to pursue its national interest as well as its will to fight. The benefit of PR then is not just about recovering "tactical and valuable assets" but also to prevent or mitigate the costs to national interest, the will to fight, and the society's support of the government.

¹⁸² O'Grady and French, *Basher Five-Two*.

¹⁸³ Simpson, *Stealth Down*.

¹⁸⁴ For the strategic importance and impact of PR, see Pera, Miller, and Whitcomb, "Personnel Recovery."

¹⁸⁵ Figure composed of images from *Daily Mail* (Nichols); *Time* magazine (Durant, June 14, 2013; O'Grady, June 19, 1995; *People* magazine (Lynch, April 21, 2003); and *Dabiq* magazine (Jordanian pilot, issue no. 7).

4. The Evolution of Personnel Recovery Doctrine

This very brief section illustrates the PR system through a doctrinal lens that provides PR guidance to isolated personnel, forces, and commanders and staffs. To put doctrine in context, the following definitions are needed:

National policy is defined as “a broad course of action or statements of guidance adopted by the government at the national level in pursuit of national objectives.”¹⁸⁶

Doctrine is “fundamental principles by which the military forces or elements thereof guide their actions in support of national objectives. It is authoritative but requires judgment in application.”¹⁸⁷

Joint doctrine consists of “fundamental principles that guide the employment of the United States military forces in coordinated action toward a common objective and may include terms, tactics, techniques, and procedures.”¹⁸⁸

Figure 24 illustrates doctrinal hierarchy from the individual to the strategic level, while Figure 25 illustrates the actual timeline, beginning in WWII, and visualizes the development of PR doctrine from the individual level through service component, joint doctrine, DOD directives and instructions, and all the way up to the presidential level and a whole of government approach to PR.

¹⁸⁶ CJCS, *DOD Dictionary of Military and Associated Terms*, JP 1-02 (Washington, DC: CJCS, 2016).

¹⁸⁷ Ibid.

¹⁸⁸ Ibid.

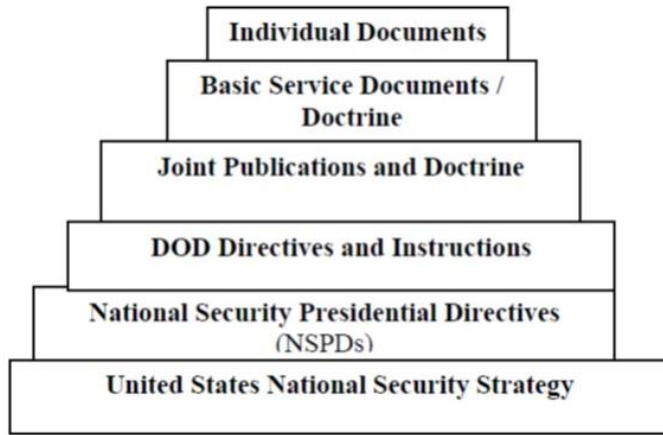

Figure 24. PR Doctrine Hierarchy¹⁸⁹

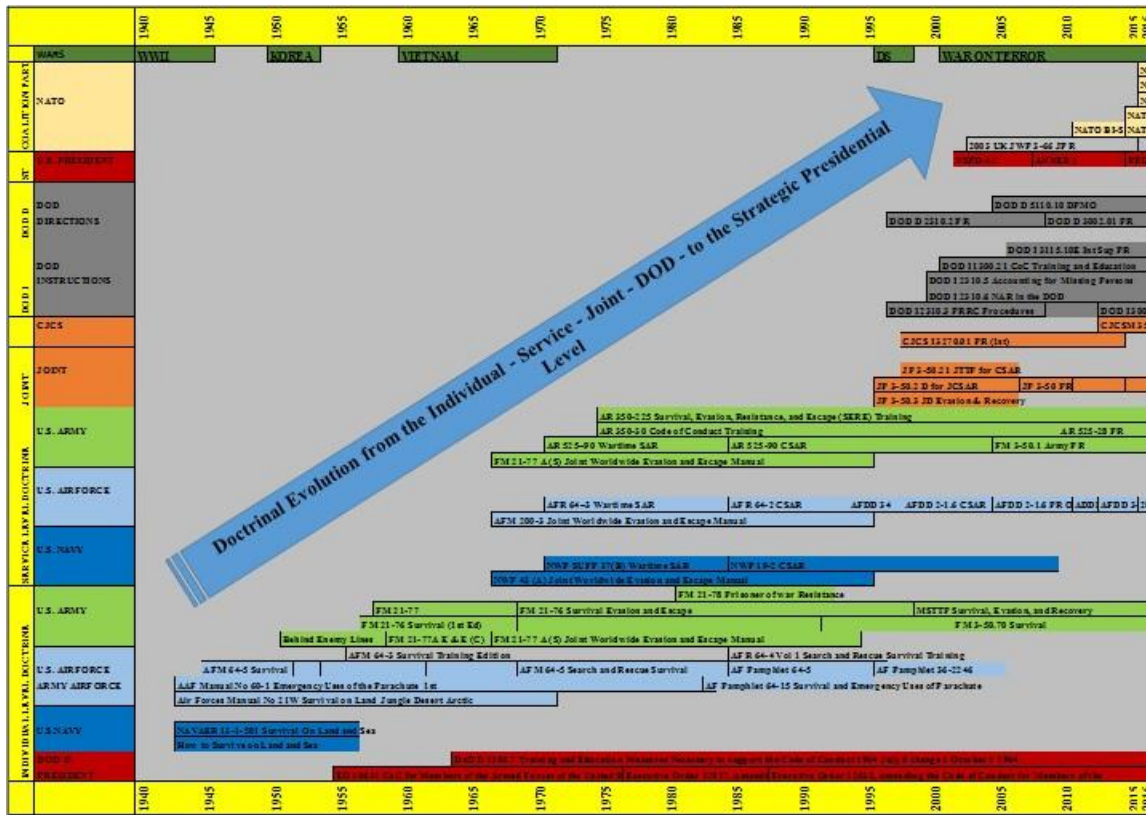

Figure 25. Timeline of the Evolution of PR Doctrine¹⁹⁰

¹⁸⁹ Dorl, "Personnel Recovery and the DOTMLPF Changes Needed," 27.

¹⁹⁰ Figure created by the author.

In sum to understand policy and doctrine in greater depth, the reader should consult Appendix F, which traces the doctrinal evolution from WWII, from the individual to the strategic level, from the IP to the president of the United States. It also includes a brief overview of the evolution of NATO's PR doctrine.

5. The Evolution of Norwegian Personnel Recovery

a. WWII–1989

The evolution of the Norwegian PR system had its origins in WWII when Norwegian pilots and SOF, operating from bases in Britain, were at risk of capture by the enemy. Therefore, pilots and SOF had a need for training that would prepare them for survival, escape, and evasion, to resist interrogation and survive captivity. Training and equipment were provided by the British Escape and Evasion organization, MI9, and their instructor organization. Inspiring tales of Norwegians' exposure to difficult survival situations, escape, and evasion and rescue efforts can be found in well-known books like *The Heavy Water Raid*, *We Die Alone*, and *The Shetland Bus*.¹⁹¹

After WWII and through the Cold War, the MI9 concept of organizing secret Escape and Evasion networks were adopted by Norway. The WWII practice continued as a secret Stay Behind (SB) organization was run by the Norwegian intelligence service as part of a greater NATO effort to prepare for a potential evacuation of government officials and the return of downed Allied pilots in Norway and Europe.¹⁹² The SB organization was secret and not known to most of the Norwegian pilots who would be the users of the network. The education and training in Personnel Recovery for pilots and SOF were limited to and focused on individual survival skills and the ability to escape and evade in Norway among a friendly population.¹⁹³

The evolution of Personnel Recovery in Norway would not change much until the fall of the Berlin Wall and the end of the Cold War. In general, NATO member nations

¹⁹¹ For the Norwegian stories, see Howarth, *Shetland Bus*; David Howarth, *We Die Alone: A WWII Epic of Escape and Endurance* (Guilford, CT: The Lyon Press, 1999), and Jens-Anton Poulsson, *The Heavy Water Raid: The Raid for the Atom Bomb 1942-1944* (Oslo: Orion Forlag, 2009).

¹⁹² Riste, "With an Eye to History."

¹⁹³ Author's discussions with former Norwegian military pilots on their PR education and training.

would be increasingly involved in expeditionary operations. Instead of fighting on a home turf with a friendly population, the focus shifted to conflicts abroad where one could expect a more hostile population. During Desert Storm, the images of badly treated pilots and SOF displayed on television by Saddam Hussein triggered a shift in training from individual *survival* in a well-known homeland environment to one of *combat survival* in a foreign theater where the ability to quickly communicate your position to rescue forces and facilitate a quick rescue became necessary.¹⁹⁴

b. 1991–2001

The RNoAF's participation in numerous operations in the Balkans highlighted the need for a change in training for its aircrews. Norwegian Bell-412 helicopters deployed to Bosnia from 1993–1996, and Norwegian F-16s participated in Operation Allied Force (OAF) in 1999. Norwegian Special Forces also deployed to the Balkans, as well as conventional forces. The nature of the conflict changed the traditional view on who was at risk and who would need combat survival training, as there was no longer a traditional forward line of own troops (FLOT). The scenario changed from one where only aircrew and SOF operated far beyond own lines in enemy territory and, therefore, were the ones who risked capture if shot down or compromised by the enemy. The new scenario exposed an increased number the conventional forces as well, since there the battlespace was less linear and more intermingled.

c. 2001–2011

The next distinct shift in operations and focus on CSAR came as a result of the 9/11 attacks and the following decade of operations in Afghanistan. Norwegian SOF became a part of Operation Enduring Freedom from the beginning in late 2001 and since then have had an almost continuous presence in Afghanistan. The RNoAF deployed F-16s in 2002–2003, and again in 2006. Norwegian C-130 transport aircraft participated in

¹⁹⁴ For an account of aircrew and special operations forces who experienced capture and becoming prisoners of Saddam Hussein's forces in 1991, see Andy McNab, *Bravo Two Zero* (London: Bantam Press, 1993); and John Peters and John Nichol, *Tornado Down* (London: Signet, 1993). These stories coincided with Norwegian instructors participating in a combat survival instructor course held by the 22 SAS in the UK, which contributed to a momentum in changing the training from survival to combat survival starting in 1995.

2002 and later deployed to Mazar-e-Sharif in 2012–2013. Bell-412 helicopters deployed to Maymaneh in 2008 and remained there until 2012. Conventional forces from the Norwegian Armed Forces also deployed several times throughout the Afghanistan campaign. The continuous, intermittent operations in Afghanistan have increased the awareness of the requirement for PR-educated and -trained personnel. The Afghanistan campaign also has increased the notion that PR education and training should extend not only to the individual, but must include commanders and staff, as well as the various forces' capabilities to support PR.

d. 2011–2016

Coinciding with the war in Libya in 2011, U.S. and NATO PR organizations highlighted the need for education of commanders and staff on PR. After the initial campaign Odyssey Dawn led by the United States, the NATO alliance and its member nations became responsible for PR, as NATO continued the campaign as Unified Protector. Norwegian and NATO education on PR started to perceive PR as a system in which no single organization or unit, on its own, would have all the required PR assets. It became clear that the various forces in the operations area would have to take more responsibility for PR, depending on their inherent capabilities, not as a dedicated force, but as one that was capable of supporting PR.

The emphasis on the role of commanders and staff in PR has started to change, probably coinciding with the fact that the bottom up–driven education of individuals, who now have reached squadron-level and unit-level command, has introduced greater knowledge and experience on PR into more of the leadership levels in the Norwegian Armed Forces. In 2014, the chief of defense also moved the responsibility for PR from the individual services to one where the RNoAF is now the Executive Agent Office of Primary Responsibility for PR in the Norwegian Armed Forces and has the authority to develop the overarching policy and doctrine for PR.

In sum, Personnel Recovery has evolved from WWII until the present by a slow bottom up–driven education of the individual pilot or SOF operator to one where the rest of the military also recognizes the need for some level of PR training. Commanders and

staff have become more involved as they have been exposed to PR requirements, especially since the Afghanistan campaign started. Various forces that have the capability to support PR have begun to recognize this reality, as there are fewer dedicated PR forces available, and the burden must be shared. The establishment of the RNoAF as the EA OPR and the development of Norwegian PR policy documents and regulations will further establish and bring forward commanders and staffs' responsibilities for more than just survival training of the individual.

The trigger for change on Norwegian PR has been the establishment of the RNoAF as the EA OPR. The purpose of this Capstone is to support the development of PR as a whole of the Norwegian DOD approach.

C. DESCRIBING THE NORWEGIAN PR SYSTEM AS A NETWORK

The archival data has provided an overview of current U.S. and NATO PR doctrine, the history of PR, the evolution of PR doctrine, and an overview of Norwegian PR.

As a result of synthesizing all this data, an important theme has emerged. Although PR is viewed in systems terms, there are no visuals that capture the system as a network. As JP 3-50 *Personnel Recovery* explained:

The ability to complete all these tasks cannot be found in one single entity but requires an organization fully *networked* to respond to an isolating event as commanders and staff are involved at various levels of command and the forces required might be drawn from different units, services, joint assets or multinational coalition partners.¹⁹⁵

Therefore, I decided to view Norwegian PR using a network lens.

The language and concepts I use to describe and analyze what I am calling the Norwegian PR Network (NPRN) are drawn from the writings of Patti Anklam¹⁹⁶ and Dr.

¹⁹⁵ CJCS, *Personnel Recovery*, I-2.

¹⁹⁶ Patti Anklam, *Net Work: A Practical Guide to Creating and Sustaining Networks at Work and in the World* (New York: Butterworth-Heinemann, 2007).

Nancy Roberts’s Network Design course at the Naval Postgraduate School (NPS). I also employ Roberts’s Network Design Framework to describe and analyze the network.¹⁹⁷

The data used in creating the “Norwegian Armed Forces Personnel Recovery Network” was drawn from the author’s study of the current working relationships among organizations currently engaged in PR as of June 2015.¹⁹⁸ A rough sketch of the relationships is found in Figure 26.

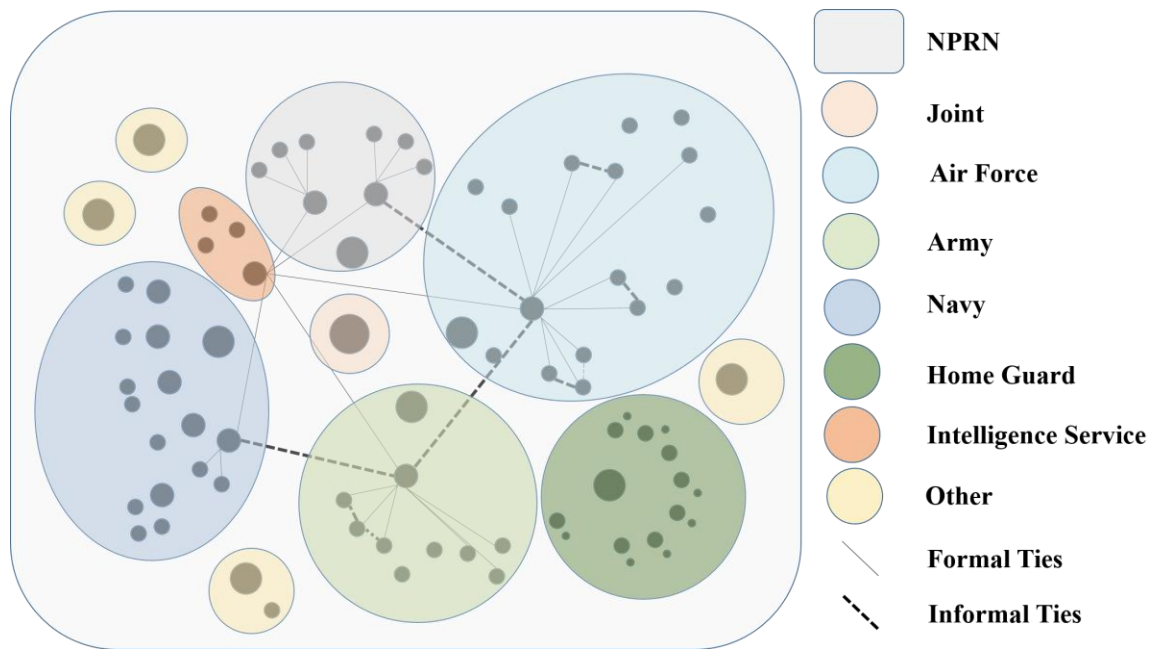

Figure 26. Norwegian PR System Links as of June 2015¹⁹⁹

To help synthesize all of the data collected from the archival records and reframing it as a network, I am using Roberts’s Network Design Framework, which is shown in Figure 27.

¹⁹⁷ Nancy Roberts, “Robert’s Network Design Framework” (PowerPoint presentation, Network Design course, Naval Postgraduate School, Monterey, California, 2015).

¹⁹⁸ For any social network analyst, the data used represent all the actors that have ties, without necessarily answering the organizational analyst’s question of whether the actors *recognize* that they are participating in the network, or if they are committed to operating as a network and building an institutional basis for the network. See John Arquilla and David Ronfeldt, *Networks and Netwars* (Santa Monica, CA: RAND Corporation, 2001), 319; and Anne Holohan, *Networks of Democracy: Lessons from Kosovo for Afghanistan, Iraq, and Beyond* (Stanford, CA: Stanford University Press, 2005), 33.

¹⁹⁹ Figure created by the author.

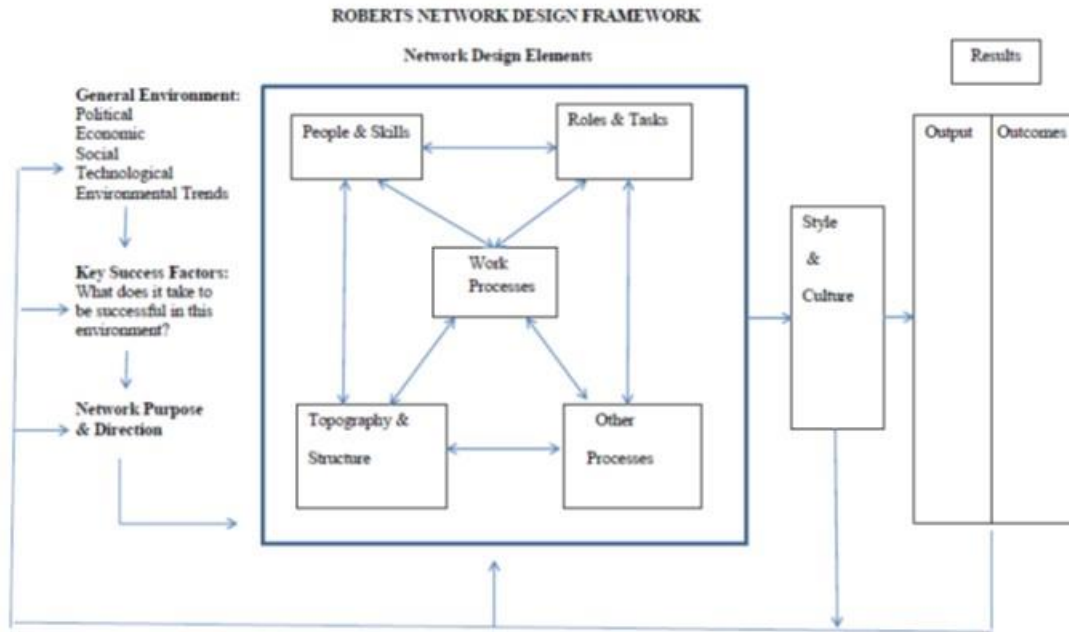

Figure 27. Roberts’s Network Design Framework²⁰⁰

a. The NPRN General Environment

The external environment in which the NPRN network organization is embedded can be thought of as two distinctly different environments. Most of the time, the NPRN operates in a peacetime environment in Norway, where education and training of the various actors in the NPRN are the main efforts. The second environment, where lives are at risk, is the crisis or wartime environment where the NPRN actors must be able to perform in multinational coalitions, executing PR missions. The current Norwegian political trend indicates continuous Norwegian participation in the operations of various alliances that will require Norwegian Armed Forces to deploy outside of Norwegian territorial borders.

In the first Norwegian environmental scenario, the NPRN will primarily face battles over resources and priorities within the Armed Forces to provide the education and training necessary to prepare and lay the foundation for a successful outcome of a PR

²⁰⁰ Nancy Roberts, “Robert’s Network Design Framework” (PowerPoint presentation, Network Design course, Naval Postgraduate School, Monterey, California, 2015).

event during crisis or war. The second scenario will be in an international environment where the Norwegian Armed Forces are deployed as part of a coalition. There have been social and political trends that place increasingly high value on each soldier, and one could argue that some loss aversion exists in Western society in general. Such loss aversion and its consequences are linked to Western nations' reactions to situations like the Black Hawk Down incident in Somalia, which some scholars say contributed to the slow response in providing ground forces in the Balkans and the late UN intervention in Rwanda.²⁰¹ The technological advances in social media and its widespread use by opponents to support their narrative could also influence the enemy's ability to exploit captured Western forces as part of their propaganda. The ISIS's burning of the Jordanian F-16 pilot captured in Syria illustrates how the enemy might use captured personnel as propaganda and as a weapon to destroy the coalition's morale.²⁰²

In contrast to the NPRN's general environment, the IP on the ground faces a more challenging physical environment. While waiting for the commanders and staffs in the network to organize the recovery efforts, the IP must be prepared to activate his/her SERE skills and knowledge to survive in three environments.²⁰³ First, he or she must survive the physical environment itself in a permissive or worse, in a non-permissive, environment by employing land, sea, and desert survival skills, as well as be able to employ the safety and survival equipment. Second, the IP must be able to survive the threat environment by evading a hostile force and, if captured, resist exploitation and interrogation, escape if possible, and prepare for extraction by PR forces. Finally, the IP must also survive the theater environment which implies that he must understand its geography, including cultural aspects, topography, and climate, and have an

²⁰¹ Paul Alexander, "Fallout from Somalia Still Haunts U.S. Policy 20 Years Later," *Stars and Stripes*, October 3, 2013, <http://www.stripes.com/news/fallout-from-somalia-still-haunts-us-policy-20-years-later-1.244957>.

²⁰² Gopal Ratnam, "The Islamic State Captures Jordanian Pilot after F-16 Crash," *Foreign Policy*, December 24, 2014, <http://foreignpolicy.com/2014/12/24/the-islamic-state-may-have-just-shot-down-an-f-16-jet/>.

²⁰³ NATO, *BI-SC Joint Personnel Recovery Joint Operational Guidelines*, BI-SC JPR JOG (Norfolk, VA: Supreme Allied Commander, Transformation, 2011), 294.

understanding of how military, governmental, and criminal elements may enforce captivity upon the individual.

b. Key Success Factors

Ultimately, the success of the NPRN network lies in its ability to execute the PR mission in three scenarios: peacetime, during a crisis, and in wartime. The foundation for success is built on the continuous efforts to educate and train the NPRN actors during the preparation²⁰⁴ phase in peacetime, on a day-to-day basis. Key success factors for the network derive from both theory and practice. From a theoretical perspective, as described by John Arquilla and David Ronfeldt, the design and performance of any efficient network span five elements:

- Organizational level: its organizational design.
- Narrative level: the story being told
- Doctrinal level: the collaboration strategies and methods
- Technological level: the information system
- Social level: the personal ties that ensure loyalty and trust²⁰⁵

As a cost-effective network, the NPRN's ability to continuously tell the story, the narrative, about its reason for being, would be a key success factor for the first scenario, the peacetime environment.²⁰⁶ A shared common understanding of how to execute the networks' primary task, to recover personnel on a doctrinal level including how the NPRN information system supports this effort, would be crucial. Arguably the most important factor for a successful execution resides in the trust and loyalty developed between and among the different actors in the network, on a continuous basis, which allows or motivates them to accept the extra risks inherent in such a mission.

²⁰⁴ The preparation phase consists of having proper policy and doctrine that drives the training and education including equipment to create PR situational awareness for isolated personnel, commanders and staffs and forces, according to the PR System Model.

²⁰⁵ Arquilla and Ronfeldt, *Networks and Netwars*, 324.

²⁰⁶ The literature review on Personnel Recovery, covering the period from WWII to the present day, supports the importance of a constant need for the PR narrative to be told to maintain the awareness of why PR is critical.

The theoretical perspective resonates quite well with the practical experience of General (Ret.) Stanley McChrystal, who highlights four areas of importance in which adaptive entities must excel, based on his personal experience of leading the U.S. Joint Special Operations Command in its fight against Al Qaeda.²⁰⁷ McChrystal describes these four areas as

- Common Purpose: The way a group of free agents is transformed into a cohesive, orderly, and aligned team around a common set of objectives
- Shared Consciousness: An emergent intelligence that is created by a holistic understanding of the operating environment and a high level of internal connectivity
- Trust: Faith in the intent and competence of one's colleagues
- Empowered Execution: The decentralization of decision-making to the lowest appropriate level.²⁰⁸

In his book *Team of Teams*, McChrystal argues that the outcome of implementing these principles is scaled excellence, in which an organization is capable of being the right thing at the right time, constantly.²⁰⁹

For the actors in the NPRN, a key success factor will be the well-educated personnel who have a such a shared mental picture of how to operate as part of this network and the ability to communicate with a language that is understood by those involved.

The PR challenges faced by isolated personnel, forces, and commanders and staffs are, not surprisingly, a complex matter involving many actors and stakeholders. The current PR system model is both influenced by and the aggregation of a long history of PR events, from WWII until the present. Comprised of lessons learned from both successful and unsuccessful rescues, the model illustrates the wide variety of involved

²⁰⁷ JSOC is in many ways the resulting joint force created as a result of a long history of failed PR events dating back to the Son Tay raid in Vietnam and ultimately the failed Iranian hostage rescue mission in Operation Eagle Claw.

²⁰⁸ Stanley McChrystal, "What Is Crosslead?" *The McChrystal Group*, accessed June 14, 2015, <http://mcchrystalgroup.com/what-is-crosslead/>.

²⁰⁹ Stanley McChrystal, Tatum Collins, David Silverman, and Chris Fussell, *Team of Teams: New Rules of Engagement for a Complex World* (New York: Portfolio Penguin, 2015), 6–7.

players who need to coordinate, cooperate, and collaborate to accomplish their common purpose of recovering an isolated person.

c. The NPRN Purpose and General Direction

The overarching purpose of the NPRN is broadly described in the following statement.

Joint PR is a system in which the objectives are to return isolated personnel to duty; sustain morale; increase operational performance; and deny adversaries the opportunity to influence our military strategy and national will by exploiting the intelligence and propaganda value of isolated personnel.²¹⁰

From a network theory perspective, *purpose* stands out as one of the key fundamental principles of networks. As network theorist Anklam states in her second principle of networks, “every network has an underlying purpose, and every network creates value.”²¹¹ She further states that “the purpose of a network is what animates it and causes its members to care about it.”²¹²

Depending on whose perspective one assumes, there are numerous ways to describe the purpose, as shown in Figure 28. Using Anklam’s description of purpose types, one can say that the NPRN most closely approximates a mission network.

²¹⁰ CJCS, *Personnel Recovery*, I-2.

²¹¹ Anklam, *Net Work*, 4.

²¹² *Ibid.*, 30.

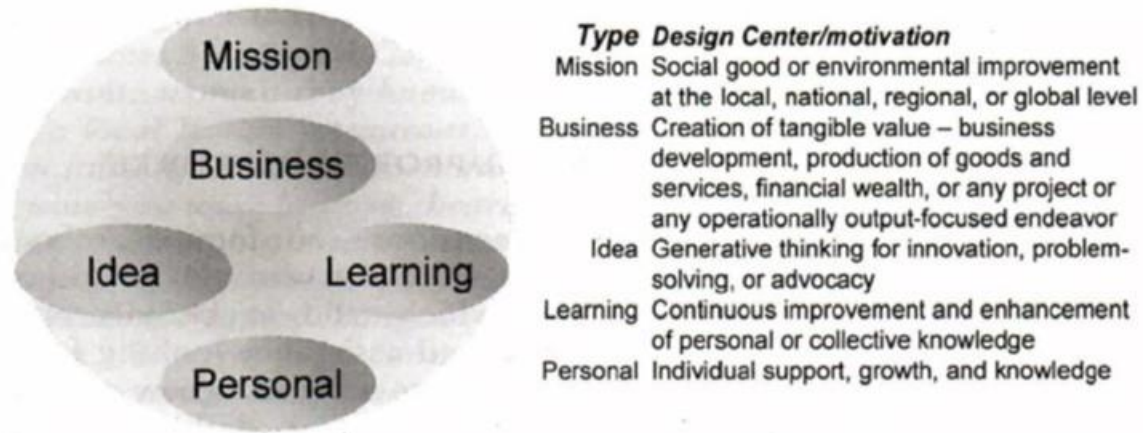

Figure 28. Network Purposes²¹³

d. NPRN Governance

The NPRN consists of numerous organizations and actors with different capabilities to support the recovery of isolated personnel. The NPRN also relies on many individuals who have PR skills and competence. As such, the NPRN consists of a blend of units with a hierarchical structure and individuals within various locations in the same hierarchical system which creates a PR knowledge or competence network. The NPRN then is similar to what Arquilla labels a hybrid-combination of a hierarchy and a self-organizing network of people and organizations.²¹⁴ These actors are parts of the Air Force, Navy, Army, and SOF, and receive support from the Intelligence and Logistical services of the Norwegian Armed Forces. No overarching governance structure exists at the moment that spans all these services, but the Air Force and the Army have what could be labeled a lead organization, as well as the SOF community that has a significant dedicated PR force with a standing hostage rescue mission.²¹⁵

The new Norwegian PR mandate of 2014 designates the Air Force as the Executive Agent Office of Primary Responsibility (EA OPR) for PR and tasked with the

²¹³ Ibid., 31.

²¹⁴ Arquilla and Ronfeldt, *Networks and Netwars*, 327–28.

²¹⁵ For the details of a lead organization, see H. Brinton Milward and Keith G. Provan, *A Manager's Guide to Choosing and Using Collaborative Networks* (Washington, DC: IBM Center for the Business of Government, 2006), <http://www.businessofgovernment.org/sites/default/files/CollaborativeNetworks.pdf>.

responsibility of PR as a whole.²¹⁶ No further doctrine describes how and what this should look like regarding the collaboration and authorities needed for cross-services cooperation. The development of such doctrine is part of the ongoing work to which this report and its recommendations contribute.

The argument can be made that, at the moment, the NPRN is more of a network of PR organizations, with ad hoc ties, without any governance or coordination that brings them together with a common purpose as a whole network.²¹⁷ If one uses social network analysis to look for ties and relationships among and between the different PR organizations and people, one finds numerous ties among the network members that are sustained over time—the definition of a social network. But at this junction, the NPRN organization and individuals cannot answer the following questions affirmatively:

- Do the actors recognize that they are participating in a particular network?
- Are they committed to operating as a network?
- Are they doing anything to build the institutional basis of the network?²¹⁸

For example, there is a network of SERE instructors from all services with ties to the Army SERE School. They are not, however, aware of one another and do not see themselves as a network. The SOF community has an organic network of actors who need to collaborate for the hostage rescue mission, but they are not necessarily known to the other services' PR organizations. There are PR ties between the services, but no overarching network governance exists across the network. Both the Army and the Air Force have network ties to the European SERE schools, as well as SERE schools in the United States and Canada, but again, there is no overarching mechanism of coordination or governance.

²¹⁶ Forsvaret [Norwegian Armed Forces], *Direktiv for luftmilitær virksomhet* [Directive for air operations], 4.

²¹⁷ Anklam, *Net Work*.

²¹⁸ Paraphrased from Arquilla and Ronfeldt, *Networks and Netwars*, 319; Holohan, *Networks of Democracy*, 33.

D. PERSONNEL RECOVERY DISCUSSIONS

Discussions with personnel also have informed the discovery phase of this capstone. They provide insights and themes on what is important to the various stakeholders involved, primarily those in Norway. To add to the Norwegian perspective, discussions also been conducted with international PR partners. For example, discussions have been held with people who represent isolated personnel, forces and commanders and staffs, including those who educate and train personnel and those who provide PR equipment.

They come from different organizations such as the RNoAF PR and SERE School, the Norwegian Army SERE School, and Norwegian SOF trainers who are responsible for PR and SERE training. Numerous participants in the RNoAF SERE C courses also have provided debriefs about their courses. Norwegian unit commanders and staffs that have deployed to Afghanistan in both ground and air scenarios, as well, participants in the 2011 air campaign as part of the U.S. Operation Odyssey Dawn and the NATO-led Unified Protector, have provided input on PR and SERE. Discussions also have been held with representatives from PR and SERE training institutions in Canada, Sweden, the UK, Netherlands, and the United States. In addition, discussions on PR have been held with students at NPS representing various units and nationalities.

The insights and themes gained from these discussions will be framed and grouped by using the PR system model as a reference. Unless specifically stated, the insights and themes are related to a Norwegian actor's perspectives.

1. Policy and Doctrine

The lack of an overarching NATO PR policy and doctrine, as well as an overarching national policy, creates an uncertain environment and leaves room for internal discussion on PR requirements and who is responsible for what. For the training institutions, this lack of clarity has created a situation that requires a constant education of especially higher levels of commanders and staffs on why PR is important and how much of it is necessary. Without a clear policy and doctrine that is available to all commanders and staffs, the education of higher command leadership has been a constant

struggle for PR and SERE trainers and service OPRs, as new people rotate through important leadership and budgeting positions in the military system that interacts with the PR system. In discussions with international PR partners, there seems to be a common concern for and a need to educate the higher leadership and to create an understanding of what the PR system demands of everyone to make it work. Higher leadership must set the doctrine and priorities needed to guide the network.

2. Education and Training

The PR and SERE education and training institutions are the main bearers of PR and SERE knowledge and competence. Due to their small community, these institutions find PR and SERE knowledge and competence to be very vulnerable, as most of the knowledge resides with the individual instructors, as well as the history of how to educate and train the larger and larger numbers of people that require it.

3. Equipment

The development of a PR and SERE survival kit adapted to the area of operation can include winter mountains and desert landscapes in the same sortie. It has been a challenge for pilots with limited space available to store gear. There is also a lack of PR policy and directives that designate responsibility for PR equipment to the various services and institutions, making coordination in the production and use of equipment frustrating and difficult.

4. Isolated Personnel

Potential isolated personnel represent the largest group of concern in the Norwegian PR system. Their interest in PR and SERE training seems to be directly linked to how likely they are to be exposed to a PR event. Those who find themselves likely to be in a position that could result in a PR situation are, for the most part, very motivated to undergo what is considered arduous training. Those who do not see themselves in the same scenario find less motivation for the same training. Moreover, the lack of clear overarching directives and instructions make it easier to avoid such training to keep them current. On the other hand, many of those who have deployed and seen the

potential for an isolating event have requested more than what continuation training requires of them, viewing training as their life insurance. This need for additional training is reflected in both the individuals and their commanders and staffs who have the responsibility of leading and sending their people into harm's way.

5. Forces

Norwegian aircrew who have been through SERE level-C training and experienced the ground perspective as isolated personnel, and who have enjoyed the support that capable air assets can provide, later find it very meaningful to support such training and exercises. Their experiences have provided them with a new perspective, on not only what their airframes can provide as a capable PR platform to isolated personnel, but also how much empathy and willingness exist to effectively support and return isolated personnel.

6. Commanders and Staffs

PR education has primarily been focused on the isolated personnel, especially for the RNoAF. The commander and staffs have benefited from training they have received as isolated personnel. But as Norway has deployed more and more forces to international operations, several discussions have highlighted the need for a more specific education in command and staff roles in planning and executing PR. In those operations that have involved people with some form of previous experience with PR, important questions were raised and addressed early in the planning phase. In other situations where none of the planners had previous experience in PR, the same type of PR questions were not addressed, and important PR issues were not raised until much later in the planning process, leading to a much shorter time for proper PR preparation by operational forces. Some commanders and staffs have felt the need for prior education and training, but the lack of national policy and doctrine and specific responsibilities have hampered the budgeting and prioritizing of staff PR planning education and training.

E. PARTICIPANT OBSERVATIONS

Participant observations are valuable in the discovery phase of design thinking to gain an understanding of people within the context of the design challenge. Observing people and how they interact with the environment reveals clues about what they think and feel, which also helps one learn about what is important to them and what they need and desire. To understand and share the feelings of another is a centerpiece of a human-centered design process as the stories people tell and things that they say and do are strong indicators of their deeply held beliefs and values.²¹⁹

For this capstone project, my background has served me well and provided me with multiple engagements with various people in different roles, forces, and command levels in the PR system. I also have gained personal experiences in many roles and in engagements with a large number of actors and stakeholders in the PR system through education and training, exercises and operations, and in the role of the RNoAF OPR for PR for a number of years.

First, I started as a long-range reconnaissance patrol (LRRP) member in the Norwegian Army Special Forces. The training and education provided me with individual-level SERE training that primarily focused on being self-sustaining and, if isolated, the ability to ensure my own recovery with minimal assistance, if any. This training left me with an appreciation for the value of the SERE skills.

Second, I had the opportunity to experience the complete opposite side of the spectrum as a member of Forsvarets Spesialkommando (FSK) that trained for hostage rescue missions as a dedicated PR recovery force. During the years at the FSK, I also received the opportunity to participate in a Combat Survival Instructor Course in the UK in 1994. The course provided lectures by a series of UK special forces members who had endured capture and captivity by Saddam Hussein's forces in Desert Storm 1991. The stories they told, combined with the level of realistic training, left their mark; I had no desire to experience this for "real" in the future, but hoped to be well prepared for the worst.

²¹⁹ See section on Empathy in d.school, "Design Process Mini-Guide."

Third, I became a pilot and participated in Operation Enduring Freedom flying an F-16. The experience of flying over a terrain that could vary from steep, snow-covered mountains to the dry, flat desert in one sortie highlighted the perspectives and challenges of SERE equipment and attempting to fit it into the very limited space of an F-16, while at the same time packing to deal with a range of environmental realities. Flying an F-16 supporting ground forces also offered me a good idea of how to support a PR situation as a capable force.

Fourth, after years of operational flying combined with my SOF and combat survival instructor background, I was assigned to the RNoAF SERE School and supported the development of the SERE level-C training and education within the RNoAF according to NATO standards. Eventually I was placed in charge of PR and, as the OPR for PR in the Air Force, gained valuable perspective in addressing PR and SERE in a broader sense, not as single training events but as a whole that included all training and continuation training for all aircrew as long as they were operational. This gave me an understanding of the challenges of keeping aircrew up to date on PR and SERE skills, as well as working with various deployments of Norwegian forces to provide appropriate SERE equipment for different airframes and environments.

Fifth, being in charge of PR and SERE education and training gave me many opportunities to get a feel for the different attitudes towards the training. People's attitudes toward education and training vary. Since the training is arduous and especially challenging for aircrews in an unfamiliar environment, people are often anxious about how they will perform before the courses. Some emerge confident in their SERE abilities and quite satisfied with their achievements. Others avoid the training if they can as long as they can, but change their attitudes after the training. They come to view it as a valuable lesson about themselves and good preparation for worst-case scenarios. At some point in the future, they could be the ones rescued.

Sixth, the costs and resources needed for training produce tensions in the PR system. Balancing the demands between cost-conscious stakeholders who want cost reductions and PR personnel who want to maintain standards produces friction in the PR

system. There is a constant question about what standards should be and as costs rise, what training is needed to meet them.

To sum up, I have had the opportunity to be a participant in many roles and functions of the PR system in addition to being an observer of others. These experiences have shaped my understanding of people's needs and desires related to PR and SERE. I am, of course, influenced and biased by my own experiences as they shape my thinking and perceptions. As such, I need to be careful during the design process that I stay true to the process and not jump to conclusions based on my own biases and preferences. In an action-oriented community, the urge is to skip the *listen and understand* aspects of design and jump into problem-solving based on one's expertise. My challenge is to keep an open mind when I am designing for others.

F. GENERAL THEMES

The goal of the discovery phase is to observe, listen to, and learn from the people involved in the PR system in order to understand their perspectives and to gain a deep understanding of their experiences. The PR system is complex, and no single perspective provides the whole picture. To understand the complexities of such a system, more perspectives must be combined to provide a rich and holistic view of the whole. Nelson and Stolterman compare the challenge as trying to see the whole of a building from the front door. It is just not possible. A building can “only be fully appreciated by moving around it, up and over it, below and through it—in other words, by moving between different station points.”²²⁰ Harold A. Linstone, in his book *Multiple Perspectives for Decision Making*,²²¹ developed a model of multiple perspectives that, when combined, “provide a richer and more holistic picture of existing complexities.”²²² Nelson and Stolterman expand on Linstone's original three perspectives of technical, organizational, and personal to allow for design, political, economic, ethical, and spiritual perspectives to

²²⁰ Nelson and Stolterman, *Design Way*, 68.

²²¹ Harold A. Linstone, *Multiple Perspectives for Decision Making: Bridging the Gap between Analysis and Action* (New York: Elsevier Science, 1984).

²²² Nelson and Stolterman, *Design Way*, 67.

enable seeing the whole, not only its parts.²²³ A similar concept of perspectives is used by the military abbreviated to DOTMLPF-P that addresses doctrine, organization, training, materiel, leadership and education, personnel, facilities, and policy.²²⁴ To extract and group the central themes that have emerged through the discovery phase, I use all of these perspectives in combination with the PR system model actors, functions, and tasks.

1. Policy and Doctrine

U.S. PR doctrine has evolved from the individual level to one of strategic policy level over almost seven decades. Beginning with WWII, PR lessons learned have been turned into written knowledge, in the form of doctrine, available to the isolated personnel, forces, and commanders and staffs all based on costly wartime experiences. With PR recognized as a whole of government approach, detailed responsibilities for the education, training, and equipment needed to support the five PR tasks (report, locate, support, recover, and reintegrate) have been clearly given to the key PR actors in the form of authoritative DOD directives and instructions clearly anchored in a strategic Presidential Policy Directive. As the United States has learned its PR lessons over many decades of war and conflict, these same lessons and their resulting doctrine are available for smaller nations like Norway to draw from in developing a PR system of their own.

2. Organization

PR created relatively large organizations as seen in WWII, Korea, and the Vietnam War with entities like the MI9 and MIS-X. Subsequently, both the UK and the U.S. Air-Sea rescue have evolved into much smaller entities dependent on other PR capable forces to support their mission. In today's PR environment, no single organization holds all the assets required, and much more inter organization collaboration is needed to make the whole PR system perform its functions and tasks. The number of

²²³ Ibid., 67–69.

²²⁴ CJCS, *DOD Dictionary*, A-52.

actors involved in PR is expanding, and fewer standing PR forces are available. More diverse forces are expected to support PR events.

3. Education and Training

The education and training of personnel to enable survival in a hostile environment have been constant, while the forces, commanders, and staff responsible for organizing and executing the rescues often have been the focus of organizational and budgetary cutbacks between wars. Consequently, the same mistakes have been made and the same lessons rediscovered as previous PR knowledge and skills have been lost between conflicts.

PR knowledge as a whole is vulnerable when the community experiences a loss of continuity of education and training, and often organizations have been forced to start all over again in building the necessary PR skillsets. There has been an enormous amount of PR knowledge learned throughout history at great cost of blood and treasure, but it seems hard to keep the knowledge alive over time as organizations experience budget cuts and reorganizations between wars.

4. Equipment

Despite the seven decades of PR evolution, survival equipment, for the most part, remains the same. Basic knowledge and equipment are still required for first aid, fire, shelter, signals, water, and food. The greatest development in equipment has been GPS technology that has enabled IP to communicate with rescue forces through handheld survival radios. For the rescue forces, technology has increased dramatically with the development of helicopters and their defensive suites, as well as sensor capabilities to fly in any weather, day or night. Commanders and staffs are able to execute real-time command and control of PR events, thanks to technology developments, although education and training in PR functions and tasks seems to be lacking for the general population of commanders and staffs involved with PR.

5. Personnel

The number of people in need for some kind of PR training has expanded rapidly since the late 1990s as operational areas have put more than just pilots and SOF in harm's

way. Commanders and staffs in general seem to have too little understanding of PR unless they have “grown up” with being potential isolated personnel and received SERE training. In Norway, the level of leadership that has received more than a survival, escape and evasion experience in a national homeland defense scenario is just reaching the level of LTC and Col in the Air Force and even less in the other services. This highlights the need to spread PR knowledge to a wider audience.

Isolated personnel have shown extraordinary will to survive and demonstrated an ability to go through hardship of survival, escape and evasion, even captivity. Rescue forces have demonstrated exceptional displays of altruism and acceptance of risk and cost to themselves in the efforts to save others, often towards a fellow soldier or pilot, but also towards total strangers. There are expectations for most individuals involved in PR, especially those who face the biggest consequences of isolation and rescues, that someone will do their best to bring them back and leave no one behind.

6. Political

PR events are tactical in nature but have the potential to become a matter of national interest very quickly. The ability of a nation or coalition to respond to a PR event before it becomes an event of enemy exploitation is important to preserve the will to fight and protect national security interests.

7. Economics and Ethics

The benefit and cost of conducting PR are very much dependent on what perspective is assumed. In a narrow economic perspective, it is very costly in monetary terms to conduct PR. But in the longer perspective and broader sense, the value of having a PR capacity is immeasurable, as it influences the will to fight and the morale of our forces, as well as the greater society’s support. In evolutionary terms, the groups that have had strong levels of altruism and will to accept risk for another group member have, at times, been critical for the group and society’s overall survival.

IV. PROBLEM DEFINITION

A. INTRODUCTION

This chapter builds on the discovery phase of design thinking in Chapter 3 to address the next phase of design thinking: problem definition. Drawing from the synthesis of the archival data, observations, discussions, and insights, problem definition creates a more refined statement of the design challenge.

B. PROBLEM DEFINITION

The initial design challenge was this:

How can we design a Personnel Recovery (PR) system for the Norwegian Armed Forces that enables Norwegian commanders and staffs, forces and isolated personnel to collaborate and operate in a Combined Joint PR mission environment?

The discovery phase provided an extensive overview of PR: what is involved in PR, its evolution from WWII until the present, its governing documents and the PR system model in Figure 29, and the lessons learned by individuals and organizations over six decades of warfighting with both successful and failed recovery missions.



Figure 29. PR System Model²²⁵

²²⁵ NATO, *Allied Joint Doctrine for Recovery of Personnel*.

A key insight from the discovery phase was that the broad range of PR actors, individuals, and units come from multiple organizations and see themselves as a collection of independent entities. They do not view themselves as part of a whole system or a network of actors and organizations that needs to work together and integrate their efforts. They are not, as JP 3-50 *Personnel Recovery* states they should be, “an organization fully networked to respond to an isolating event.”²²⁶

C. THE PR NETWORK AS OF 2014

A network is defined as two or more nodes that have a sustained connection over time.²²⁷ Social networks are the focus in this study—in particular, the networks of people and organizational units that make up the PR system. The Norwegian PR network as of 2014 is illustrated in Figure 30.

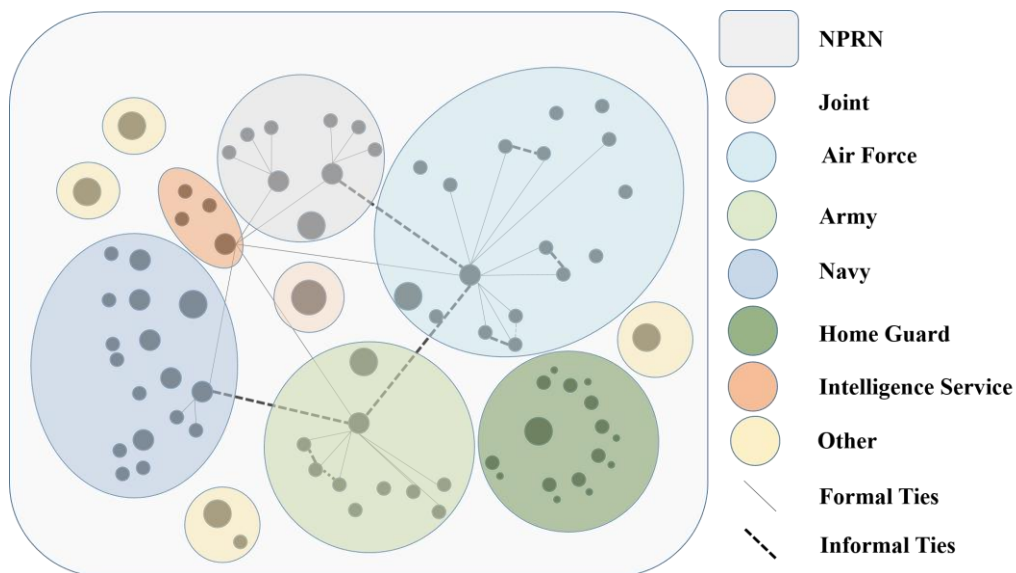

Figure 30 depicts the overall PR network as of 2014 representing the services and their interorganizational ties or lack thereof, as well as the intraorganizational (within services) ties.

Figure 30. Norwegian PR Network at Capstone Initiation in 2014²²⁸

²²⁶ CJCS, *Personnel Recovery*, I-2.

²²⁷ Professor Nancy Roberts, “Network Design” (PowerPoint presentation, Network Design course, Naval Postgraduate School, Monterey, California, 2015); and Sean F. Everton, *Disrupting Dark Networks* (New York: Cambridge University Press, 2012), 9.

²²⁸ Figure created by the author.

By June 10, 2014, the formal authorities over the Norwegian PR system were as follows. In the Air Force, Luftforsvarets Flytaktiske Skole (LFTS) [The RNoAF Tactical Flying School] was designated by service regulation as the OPR for all SERE education and training in the Air Force. In the Army, Forsvarets Vinterskole (FVS) [The Norwegian School of Winter Warfare] was designated by service regulation as the OPR for their SERE education and training. The Intelligence service and Forsvarets skole i etterretnings- og sikkerhetstjeneste (FSES) [Norwegian Armed Forces School of Intelligence and Security Service] were designated as the OPR for conduct after capture education and training for all services. The Norwegian Special Forces were responsible for their SERE education and training.

As Figure 30 illustrates, in both the Army and in the Air Force, there were formal ties from the service organization designated as the OPR for SERE to each service organization/unit that required SERE education and training. Figure 30 also illustrates that there were formal ties from FSES, the Intelligence service OPR for conduct after capture training, to both the Army OPR and the Air Force OPR, as well as to SOF. In addition to the formal ties, there were also some informal relations between the service organizations.

The problem with this configuration is that each service OPR was designed to be a separate SERE education and training organization for isolated personnel and not for the overall PR and SERE structure. As such, no overarching governance structure existed for PR and SERE in the Norwegian Armed Forces that connected the services' efforts. Currently, as show in Figure 30, the Air Force, Army, and SOF PR and SERE training organizations are separate components with some informal ties to each other. In each service, there are numerous isolates, organizations that are important to the PR system but not connected. Examples of isolates are the important PR command and control (C2) architecture, the Joint Personnel Recovery Center (JPRC), Personnel Recovery Coordination Cell (PRCC), and the services' higher headquarters.

D. THE REDESIGN OF THE NORWEGIAN PR SOCIAL NETWORK

To assist participants in understanding how the PR network functions as a whole and to consider alternatives for reconfiguring the network, I use the model in Figure 31 as a general guide.

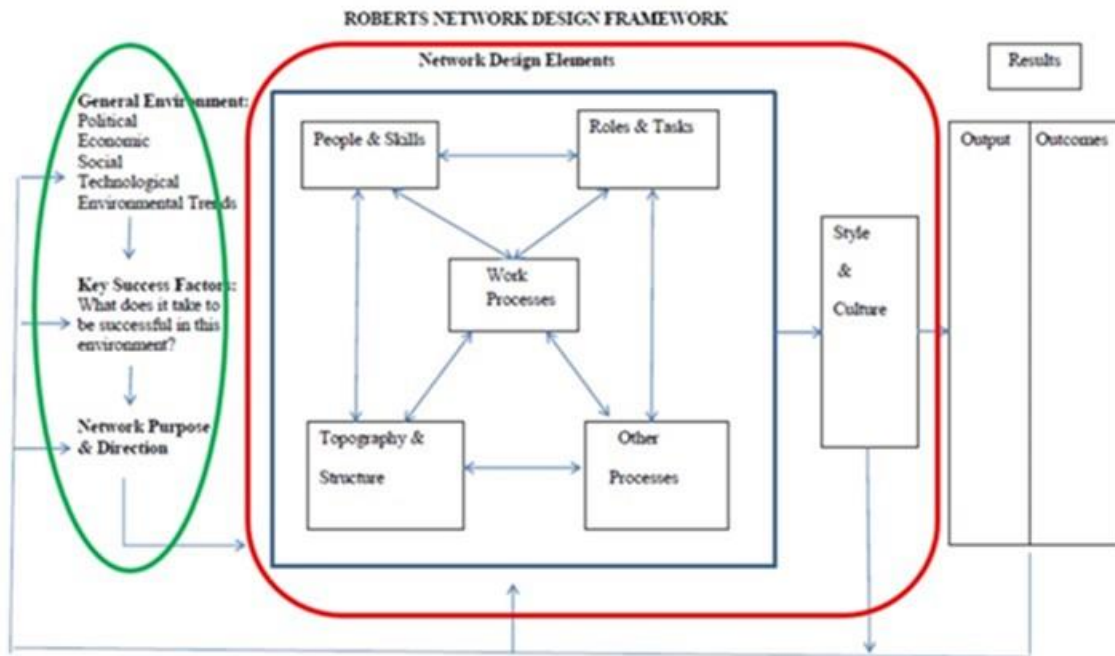

Figure 31. Roberts's Network Design Framework²²⁹

It describes the major elements that need to be considered in building or redesigning a network. Starting on the left-hand side, we find general political, economic, social, and environmental trends in a network's external environment and the key success factors—what it takes to be successful in this environment. For the NPRN, both the general environment and key success factors were summarized in the Discovery chapter. The network's purpose and direction follow. As recapped in the Discovery chapter, the NPRN's purpose and mission are described below.

²²⁹ Nancy Roberts, "Roberts' Network Design Framework" (PowerPoint presentation, Network Design course, Naval Postgraduate School, Monterey, California, 2015).

Joint PR is a system in which the objectives are to return isolated personnel to duty; sustain morale; increase operational performance; and deny adversaries the opportunity to influence our military strategy and national will by exploiting the intelligence and propaganda value of isolated personnel.²³⁰

The specific design elements in the center of the network model describe how the network's purpose and direction are executed. People (the network members) and their skill sets are an important part of any social network. In addition, people are assigned particular roles and specific tasks to do their jobs, as described in the Discovery chapter. Work processes describe how the network as a whole gets its work done. In the case of the NPRN network, work processes involve the reporting, locating, supporting, recovering, and reintegrating isolated personnel. The network's structure describes how people are connected to other people and units. And the network processes keep the network integrated (e.g., communication; training and education of isolated personnel, commanders, staffs, and forces; planning and decision making). The network's culture is the manifestation of the network's values and beliefs that describe how people actually behave and treat one another. The network's performance is measured in terms of its results measured in terms of its outputs and its longer-term outcomes. Both should be tied directly to the network's purpose and direction in order to determine how well the network is executing its mission.

All of the elements of the network's design need to be congruent, meaning they need to "fit" together and be mutually compatible. However, through the Discovery process, there were some major incongruencies in the network:

1. Doctrine

No overarching joint PR doctrine existed in the Norwegian Armed Forces, or in NATO, until 2016 when the *Allied Joint Doctrine for Recovery of Personnel in a Hostile Environment*, was published.²³¹ Prior to that document, the only Norwegian PR doctrine in place concerned service regulations for SERE education and training of isolated

²³⁰ CJCS, *Personnel Recovery*, I-2.

²³¹ NATO, *Allied Joint Doctrine for Recovery of Personnel*.

personnel, which is only one of the three core actors in PR. No Norwegian PR doctrine existed that included all actors and major stakeholders and addressed the PR system as a whole.

2. Governance

The 2014 CHOD *Directive for Air Operations* [Direktiv for luftmilitær virksomhet] established the RNoAF as the EA OPR for PR.²³² The CHOD directive for the first time established the governance of PR at a joint level and embraced the PR system as a whole, and not limited to only the SERE education of isolated personnel. Actions are ongoing related to governance of the Norwegian PR system, but there exist incongruencies at three levels. First, there is no governance at the interorganizational level. Only the EA OPR for PR has been established for the RNoAF. Second, at the intraorganizational level within the services, there is governance of SERE education training at the SERE C level, but not for the whole service PR network that includes all actors like commanders and staffs, forces, and other supporting agencies. Third, there is a lack of a formal PR C2 architecture that is designated in each service and manned by fully educated and trained PR planners and operations officers.

3. Network Processes

There are incongruities in three network processes: there is no training of additional PR actors like commanders and staffs, capable forces, and isolated personnel at the SERE A and B levels; there is a lack of PR planning capability; and there is no PR communications system that enables the network to collaborate and coordinate its activities.

4. Structure

Most importantly, as shown in Figure 30, the network's structure is not congruent or compatible with the network's mission—to be integrated into a whole system with which the members can identify. Instead the members are grouped into separate

²³² Forsvaret [Norwegian Armed Forces], *Direktiv for luftmilitær virksomhet* [Directive for air operations].

components with only weak ties among the components. According to congruence theory, the lack of congruence among a system's elements will degrade the system's performance parts.²³³ All efforts need some alignment into an integrated whole.

In the summer of 2014, the CHOD established numerous new executive agent (EA) [*fagmyndighet*] responsibilities throughout the Norwegian Armed Forces to clarify which service was responsible for what. PR and SERE was one such area that needed a dedicated overall responsible service, and the Air Force was designated the EA for PR and SERE, formalized by CHOD directive on June 11, 2014.²³⁴ The designation as an EA implies the following authorities on behalf of the CHOD:

- Authority to initiate, approve, decide, publish regulations, certify, authorize and control professional relationships within an assigned area of responsibility [PR and SERE]
- EA activity [PR and SERE] must be coordinated with other relevant EA activities involved and their commanders.²³⁵

Figure 32 illustrates the RNoAF as the EA for PR and SERE for the Norwegian Armed Forces as seen in a network perspective.

²³³ For a brief overview of congruence theory, see Mercer Delta Consulting, *The Congruence Model: A Roadmap for Understanding Organizational Performance* (New York: Mercer Delta Consulting, 2004), 1–12, http://ldt.stanford.edu/~gwarman/Files/Congruence_Model.pdf.

²³⁴ Forsvaret [Norwegian Armed Forces], *Direktiv for luftmilitær virksomhet* [Directive for air operations].

²³⁵ Forsvarssjef [Chief of defense], *Direktiv for delegering av myndighet* [Directive for delegation of executive agent responsibilities] (Oslo: CHOD, December 10, 2009), 3.

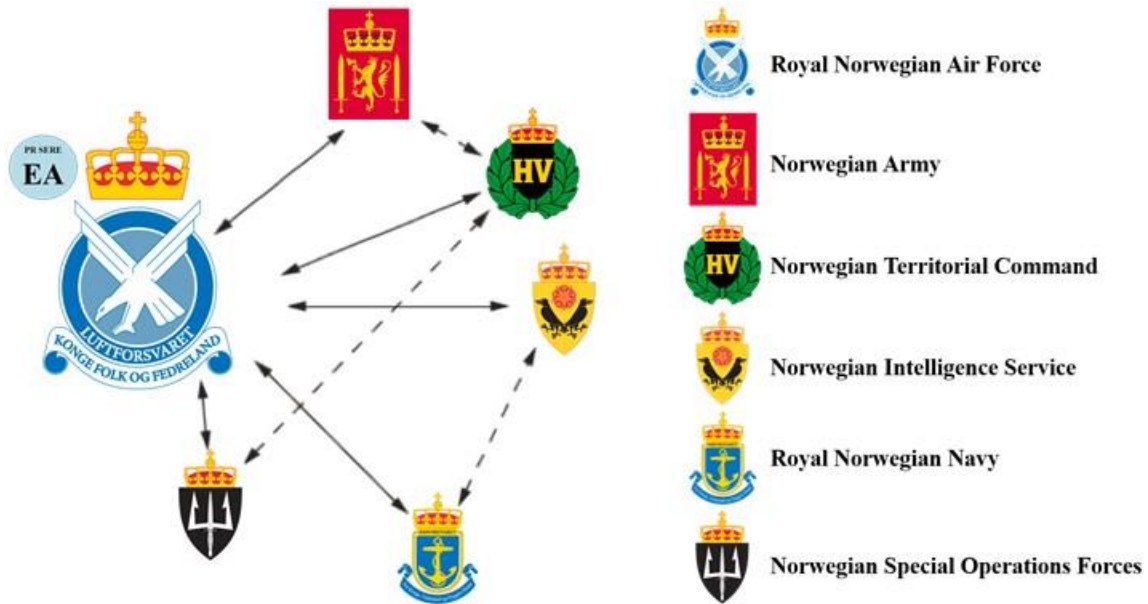

This figure depicts the RNoAF as the EA for PR and SERE for the services as depicted clockwise from the top center: the Norwegian Army, the Territorial Command, the Intelligence Service, the Royal Norwegian Navy, and NORsOF.

Figure 32. RNoAF EA of PR and SERE in a Network Governance Perspective²³⁶

As the newly designated EA for PR and SERE, the RNoAF now became the lead service responsible for PR and SERE for the whole of the Norwegian Armed Forces. This new EA role follows the pattern outlined by Kenis and Provan when networks of a certain size grow so large that they require one node in the network to assume greater authority for network coordination and integration. Kenis and Provan outline three structural options: self-governed network, lead organization network, and network administrative organization, as seen in Figure 33.

²³⁶ Model made by the author, adapted from Milward and Provan, *Manager's Guide*, 23.

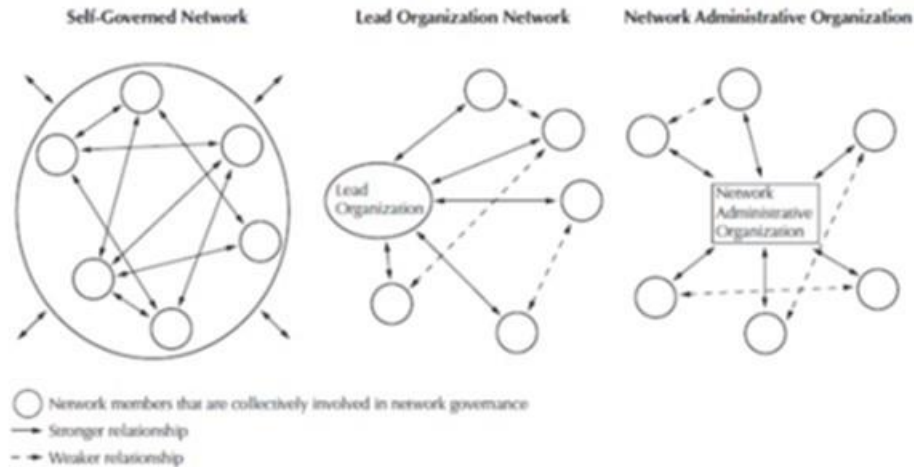

Figure 33. Modes of Network Governance²³⁷

These three forms of governance differ in what they can do well.²³⁸ The self-governed network structure, also sometimes called shared governance network because its governance is shared by its participants, is the simplest one.²³⁹ This model has no central governance, as its members all share the responsibility for the network’s decisions and activities. Its strength resides with the inclusion and involvement of all its members and its flexibility and responsiveness to their needs.²⁴⁰ Kenis and Provan posit that this model is best suited “to small, geographically concentrated networks where full and active face-to-face participation by network participants is possible.”²⁴¹

The lead organization governance model is most often seen when one organization is the core provider of resources or services and central in the flow between resources and clients.²⁴² In this network governance structure, members all share some common purpose and can maintain individual goals, but the key activities and decisions

²³⁷ Milward and Provan, *Manager’s Guide*, 23.

²³⁸ Patrick Kenis and Keith G. Provan, “Towards an Exogenous Theory of Public Network Performance,” *Public Administration* 87, no. 3 (July 2009): 446, doi: 10.1111/j.1467-9299.2009.01775.x.

²³⁹ *Ibid.*, 446.

²⁴⁰ *Ibid.*

²⁴¹ *Ibid.*

²⁴² *Ibid.*, 447.

are coordinated through one of the members acting as a lead organization.²⁴³ The strength of the structure is its efficiency and legitimacy, and as Kenis and Provan state, “because of its capacity to take on most of the responsibilities of running and coordinating network activities, most of the complexity and messiness inherent in the self-governed model can be avoided.”²⁴⁴

The network administrative organization (NAO) is a network governance structure that is set up to manage the network activities when coordination and integration become overwhelming for the lead organization. In this case, a separate organization is established, independent of the other organizations of the network, to take on the network’s coordination and integration activities.²⁴⁵ The strengths of the NAO are its efficient day-to-day management of a large number of actors—that is, the network as a whole—its engagement with strategic PR actors, and that it is sustainable.²⁴⁶

Milward and Provan provide an overview of the three network governance design options in Figure 34. They describe their three structures, and their optimal number of members, their locus of decision-making, and their advantages and disadvantages.

²⁴³ Ibid.

²⁴⁴ Ibid., 448.

²⁴⁵ Ibid.

²⁴⁶ Ibid.

Design Characteristics	Self-Governance	Lead Organization	Network Administrative Organization
Structure	No administrative entity, participation in network management by all members	Administrative entity (and network manager) is a major network member/service provider	Distinct administrative entity set up to manage the network (not a "service provider")—manager is hired
Optimal number of members	Few	Many	Many
Decision making	Decentralized	Centralized	Mixed
Advantages	Participation, commitment by members, ease of forming	Efficiency, clear network direction	Efficiency of day-to-day management, strategic involvement by key members, sustainable
Problems	Inefficient—frequent meetings, difficulty reaching consensus, no network "face"	Domination by lead organization, lack of commitment by members	Perception of hierarchy, cost of operation, complex administration

Figure 34. Network Governance Structure Options²⁴⁷

When the CHOD designated the RNoAF as the EA of PR and SERE, it created new challenges for the RNoAF. The RNoAF Tactical Flying School [LFTS], as the previous OPR for SERE in the RNoAF, now became responsible for the Norwegian Armed Forces PR system as a whole. In essence, it became a lead organization. Besides doing the education and training of RNoAF aircrew as isolated personnel, it now took on responsibilities for the coordination and integration of the NPRN.

One year into the capstone project, feedback from those working on the development of the Norwegian PR system indicated that the lead organization model was quite demanding for the RNoAF. Discussion with the principal actors revealed that although the work was moving forward, the lead the organization model of governance needed fuller consideration.

E. PROBLEM REFRAMED

The initial design challenge was how to design a Norwegian PR system that would enable isolated personnel, forces, and commanders and staffs, to operate in a coalition environment.

²⁴⁷ Milward and Provan, *Manager's Guide*, 22.

However, the design challenge had to be reframed in the light of the information collected in the discovery phase. The first problem was how to help the PR system view itself as a social network. As it was operating, network members identified with their organizations and were not aware of their connections as a network of organizations. Furthermore, members had little understanding of how a network could be designed to ensure network performance. Most importantly, there was little understanding of how the network's design elements needed to be congruent with one another. Major mismatches were found in the network's lack of overarching PR doctrine; educated PR planners and operations officers at the JPRC, PRCC, and higher headquarters levels; and in general, PR system knowledge outside the core training institutions. These mismatches required a redesign of the network.

A second problem emerged when the Air Force became the lead organization (EA) for the PR network. It quickly became apparent that taking on this responsibility in addition to its mission of education and training of isolated personnel was overtaxing its resources and capabilities. Thus, a second problem arose: How could the PR network be redesigned to correct some additional design tensions introduced with the new lead organization governance model? Both of these problems become the focus of Ideation in the next chapter—how to redesign the PR network to correct its misalignments and ensure better network performance.

V. IDEATION

A. INTRODUCTION

The ideation phase of the design process generates new ideas. By launching brainstorming sessions with “how might we” questions, the objective is to come up with solutions to the problem or issue identified in the problem definition phase. This section briefly highlights the ideation question asked, the ideas generated, and the criteria used to prioritize which ideas should be turned into prototypes.

The ideation question was this: How might we redesign the PR network to correct the misalignments and to improve performance?

Brainstorming centered around three major areas where incongruities surfaced: network governance, including the network structure; network processes; and doctrine.

1. PR Network Governance and Structure

Four options on how to address governance of the PR network were discussed: shared governance; lead organization governance; a network administrative organization; and a combination of all of the above, tailored to different levels of the PR system.

Recognizing the span of the PR network from the strategic to the tactical, interorganizational to intraorganizational, from the joint level to an individual level, the following criteria were used: the ability to coordinate; the reach to all members; the expertise and leadership available at all levels; and the ability to build relationships in the network.

Coordination is defined as bringing “different elements of (a complex activity or organization) into a relationship that will ensure efficiency or harmony.”²⁴⁸ *Reach* is the network leadership’s ability to connect with the greatest number of PR network members to provide input and to receive feedback. Expertise is expert skill or knowledge in a particular field, in this case, PR. Leadership at all levels is the ability to act and make

²⁴⁸ Google, “Coordinate,” accessed June 8, 2016, <https://www.google.com/webhp?sourceid=chrome-instant&ion=1&espv=2&ie=UTF-8#q=coordinate%20definition>.

prudent PR judgments, based on PR expertise, to facilitate the best outcome to a PR event, be it training, exercises, crisis, or war. Building relationships is the ability to enhance member interactions to gain trust, build social capital, and develop PR knowledge and skills.

Based on this set of criteria, the fourth option, the combination of shared, lead, and administrative organization governance was found most promising and merited further prototyping. The idea was to provide not just one type of governance to fit the whole PR system but to leverage each form of governance, and its advantages, at different levels of the PR network, at both the interorganizational and the intraorganizational, and from there, build out all the subnetwork structures. The authority network that derives from the governance structure is illustrated in Appendix E.

2. PR Network Processes

To improve network processes, two main ideas surfaced. The first was to build a robust informal PR community of practice (CoP). The second was to establish a formal communications system and build a repository of PR knowledge gained through seven decades of PR history.

a. PR Community of Practice

The successful outcome of PR is dependent on practitioners who can make wise decisions and take actions. These practitioners can be thought of as a PR community of practice defined as

a group of people who share a common concern, a set of problems, or interest in a topic and who come together to fulfill both individual and group goals. CoPs often focus on sharing best practices and creating new knowledge to advance a domain of professional practice. Interaction on an ongoing basis is an important part of this.²⁴⁹

²⁴⁹ Darren Cambridge, Soren Kaplan, and Vicky Suter, *Communities of Practice Design Guide: A Step-by-Step Guide for Design & Cultivating Communities of Practice in Higher Education* (Washington, DC: EDUCAUSE Learning Initiative, 2005), <http://www.educause.edu/library/resources/community-practice-design-guide-step-step-guide-designing-cultivating-communities-practice-higher-education>.

A CoP is beneficial to the NPRN because it can accumulate the actions, thinking, and conversations among the members that form an important part of their ongoing experience. Knowledge of PR resides in the members' skills and their relationships, as well as their artifacts—the documents, technologies and tools, and their formal processes that are the embodiments of their knowledge.²⁵⁰

b. *Formal Communications System and Repository of PR Knowledge*

The second idea was to develop a formal information and communication system and a repository of PR knowledge. The criteria used to choose from among the alternatives included the ability to develop a cohesive PR team around common PR objectives; the ability to build trust between isolated personnel, commanders and staffs, and forces; the ability to build PR situational awareness and an understanding of PR as a system for all actors; the ability to develop PR knowledge among PR actors; accessibility to stored PR knowledge; and the ability to execute decentralized decision making.

After numerous iterations, the decision was made to combine the two ideas and to develop a prototype that created a CoP in combination with a formal information communication system that contained both a classified and an unclassified version to reach as many PR actors as possible, and at the same time provide required information security.

3. PR Doctrine

Regarding PR doctrine, two options were identified: write new PR doctrine for Norway because none existed, or modify and adapt existing U.S. and NATO PR doctrine to fit the Norwegian Armed Forces structure.

Criteria used were the ability to create a shared understanding of PR within the Norwegian Armed Forces and coalition partners; interoperability between services and coalition nations; standardization of education and training, procedures, functions, and tasks.

²⁵⁰ Richard McDermott, "Why Information Technology Inspired, but Cannot Deliver Knowledge Management," *California Management Review* 41, no. 3 (1999): 103–17.

During the capstone process, NATO published new PR doctrine built on the U.S. JP 3-50 *Personnel Recovery*,²⁵¹ and the United Kingdom archived their JWP 3-66 *Joint Personnel Recovery*²⁵² and replaced it with the *Allied Joint Doctrine for the Recovery of Personnel in a Hostile Environment* (AJP-3.7). These events revealed a clear priority for how to proceed with the Norwegian PR doctrine, and as the newly adapted British version of the AJP-3.7 states: “The need to achieve maximum coherence and interoperability within, and between, our closest allies and partners is vital. ... We should use NATO doctrine wherever we can, and ensure coherence of UK doctrine with NATO wherever we cannot.”²⁵³ For Norwegian PR doctrine, the prototype therefore addresses the option to adapt U.S. and NATO doctrine and address approaches to operations particular to Norway as needed in national supplements and regulations, and it especially highlights the NPRN network approach to PR. Based on these developments, the design team decided not to write the doctrine itself, but provide guidelines and criteria for its development. The guidelines can be found in Appendix F.

In sum, the ideation phase resulted in the pursuit of two prototypes: a network governance model that also includes an authority network based on the relationships among commanders and staffs, forces, and isolated personnel and the services’ training institutions; and a multiservice PR community of practice that encourages participation among all PR members, including international actors, supported by a formal information communication system.

²⁵¹ CJCS, *Personnel Recovery*.

²⁵² Ministry of Defence, *Joint Personnel Recovery*.

²⁵³ Ministry of Defence, *Allied Joint Doctrine for Recovery of Personnel in a Hostile Environment*, Edition A, Version 1 with UK National Elements, AJP-3.7 (London: Ministry of Defence, February 2016), i.

VI. PROTOTYPE AND TESTING

A. INTRODUCTION

The prototyping phase can range from making simple physical models of a new product to a storyboard for a process or an operation, or a simple simulation. Having gone through the ideation phase, the design team selected the two ideas they believed merited prototyping: a multilayered PR network governance model, and a Personnel Recovery CoP. Prototyping on PR doctrine is currently underway in Norway and is not complete enough to be presented in this capstone.²⁵⁴ The development of the two prototypes and their testing and implementation are addressed in this chapter.

B. PROTOTYPE DEVELOPMENT

1. The NPRN Multilevel Governance Model

The first idea is to provide not just one type of governance to fit the whole PR system but to leverage the advantages of each form of governance at different levels of the PR network, from the strategic to the tactical level. The first prototype, therefore, is the creation of such a governance structure that spans the whole PR system and addresses the collaboration and coordination among the services and other key organizations as well as the intraorganizational level within each service. The intent of the new governance model is to increase the ability to coordinate, expand the reach to all members, provide expertise and leadership at all levels, and increase the ability to build relationships in the network.

2. The NPRN Community of Practice

The second idea is to combine the idea of a PR CoP with a formal information communication system, with classified and unclassified versions, to reach as many PR actors as possible, and at the same time, provide required information security. The intent is to create a PR community of practice that serves as a repository of PR knowledge and

²⁵⁴ The development of PR doctrine from WWII until the present and recommendations on the development of Norwegian PR doctrine and regulations are available in Appendix F.

competence. As such, the CoP is responsible for keeping PR competence alive and making sure the NPRN learns from previous PR mistakes, draws benefits from best practices, and enables adaptations as conditions change. In other words, the prototype calls for a CoP that retains the learning that the PR network has paid in blood and treasure to acquire.

C. THE NPRN MULTILEVEL GOVERNANCE MODEL

The NPRN governance prototype is designed to address the whole network from the strategic to the tactical, from the joint to the individual levels and adopt a governance model that includes all actors. The prototype exploits the advantages of each of the three types of governance introduced in Chapter 4, by designating each to its own level of the PR system model and network structure, as seen in Figure 35.

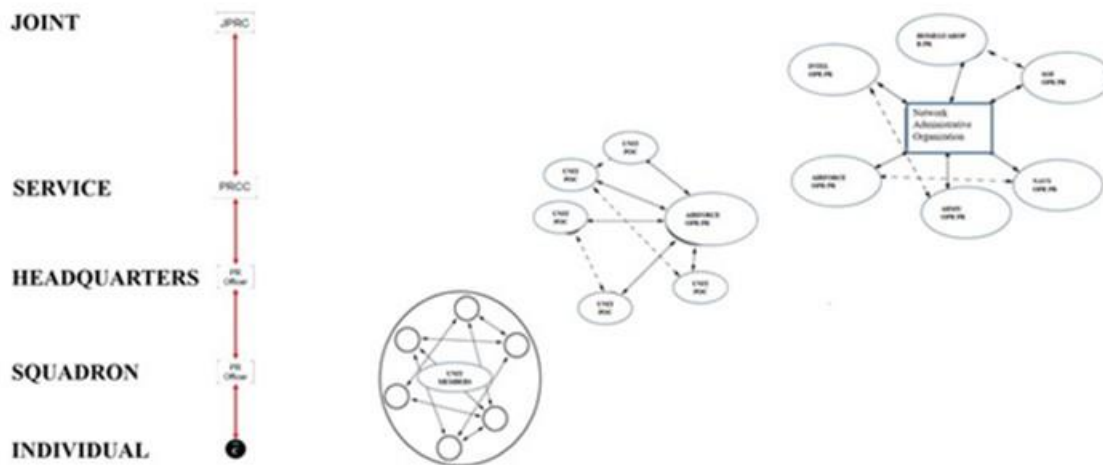

Figure 35. NPRN Network Governance Prototype²⁵⁵

The three governance forms slightly overlap each other. The NAO governance mode emphasizes the management of the overall network structure and the interorganizational PR network, with specific focus on the joint- and service-level actors. The lead organizations from each service primarily govern their own service network, the

²⁵⁵ Prototype model built by the author. Governance models adapted from Kenis and Provan found in Milward and Provan, *Manager's Guide*, 22.

intraorganizational PR network. At the squadron and unit level, the self-governance mode is used, and the PR officer or SERE instructor is the link to the upper echelons of the governance structure. This governance prototype is assessed to provide the most efficient governance structure for the NPRN and cover all actors in the PR system.²⁵⁶ Each governance mode is placed at a level, the interorganizational, the intraorganizational, and the unit or squadron level, which seeks to exploit the governance models' strengths and avoid their weaknesses. The NPRN governance prototype recommends a two-stage process: stage one builds the interorganizational NAO governance structure; stage two builds the intraorganizational lead organization governance structure in each service.

1. Network Administrative Organization (Interorganizational)

In stage one, the idea behind the NAO model is to set up a separate administrative entity to manage the governance of the network as a whole with a specific focus on the interorganizational level.²⁵⁷ Kenis and Provan depict the varying size of the NAO as “modest in scale, consisting of only a single individual, often referred to as the network facilitator or broker, or it may be a formal organization.”²⁵⁸ The design team recommends that the NAO, as a network hub, be set up by a CHOD mandate. In addition, since the RNoAF is, as of 2014, the executive agent (EA) in charge of PR for the whole of the Norwegian Armed Forces, the design team recommends that the RNoAF set up the NAO to serve the overall management of the NPRN, coordinate with the interorganizational stakeholders in each service, and identify their PR network actors and their responsibilities. The NAO would be linked to the PR lead organizations in each service, as seen in Figure 36.

²⁵⁶ For additional information on network efficiency and key predictors, see Patrick Kenis and Keith G. Provan, “Modes of Network Governance: Structure, Management, and Effectiveness,” *Journal of Public Administration Research and Theory* 18, no. 2 (2008): 236. doi:10.1093/jopart/mum015.

²⁵⁷ Ibid.

²⁵⁸ Ibid.

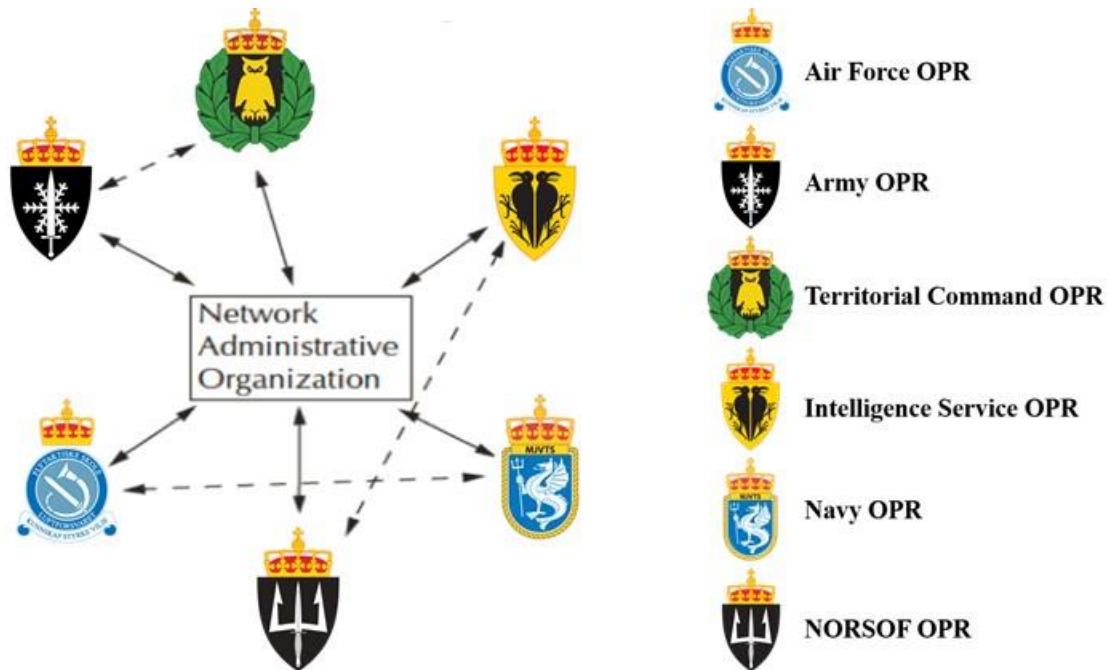

Figure 36. NPRN and the NAO at the Interorganizational Level²⁵⁹

The NPRN PR OPRs in this prototype are those organizations that hold the current de facto lead position on PR competence in each service. As of 2016, the RNoAF has an established service OPR in LFTS, also known as the Royal Norwegian PR and SERE School, which is also the acting EA for PR in the Norwegian Armed Forces. The Army and the School of Winter Warfare hold the OPR for SERE for the Army. The Intelligence services' OPR is FSES and their Conduct after Capture unit, which is also the EA for all conduct after capture training in the Norwegian Armed Forces. The design team recommends that NORSOF designate the OPR PR where they see fit in their organizational structure and identify the actors assigned to the NAO and the NPRN. The Navy has a strong OPR in their education and training institution MJVTS, and it is recommended that MJVTS be designated as an official OPR PR. For the Territorial Army (the Home Guard), one option is to place the responsibility on one of their educational institutions or potentially combine the OPR PR with the regular Army OPR PR.

²⁵⁹ Prototype model built by the author. Governance models adapted from Kenis and Provan found in Milward and Provan, *Manager's Guide*, 22.

Given its mission, the NPRN needs to build ties with coalition partners. Figure 37 shows that the NAO at the interorganizational level of the network could also build connections with relevant PR actors outside of Norway.



Figure 37 illustrates the external links to PR actors outside of Norway here represented by some of the key actors: The European Union, NATO, JPRC as the U.S. EA for PR, and the newly established EPRC.

Figure 37. NPRN and the NAO and the External PR Network²⁶⁰

There exist some current connections with external PR actors, and it is recommended that the NAO and the services' lead organizations continue to build on these connections and work to formalize the most important ones, like with the newly established European Personnel Recovery Centre (EPRC)²⁶¹ and the long standing EA of PR in the United States, the Joint Personnel Recovery Agency (JPRC).²⁶²

²⁶⁰ Prototype model built by the author. Governance models adapted from Kenis and Provan found in Milward and Provan, *Manager's Guide*, 22.

²⁶¹ The European Personnel Recovery Centre was inaugurated on July 8, 2015. For information on the establishment of the EPRC, see "The European Personnel Recovery Centre," accessed June 8, 2016, <http://www.euroairgroup.org/project/european-personnel-recovery-centre-eprc/> and "European Personnel Recovery Centre," accessed June 8, 2016, <http://eprc.it/>

²⁶² "Joint Personnel Recovery Agency," accessed June 8, 2016, <http://www.jprra.mil/>

2. Lead Organization (Intraorganizational)

In stage two, the NPRN governance prototype calls for each service to designate a lead organization to manage the internal service PR network. Figure 38 illustrates the RNoAF PR and SERE School, and the Army Winter Warfare School, as examples of lead organizations.

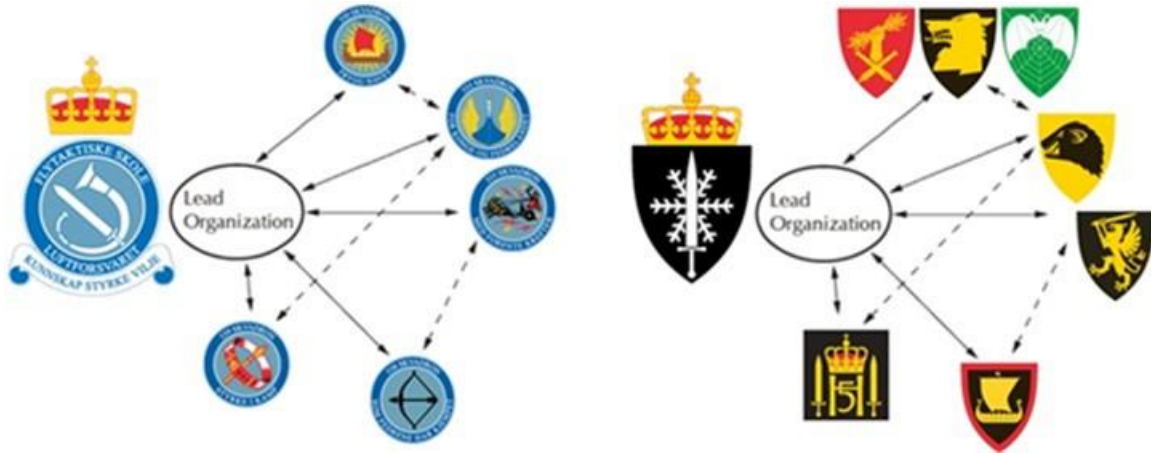

The left side of the figure shows the RNoAF PR and SERE OPR, the Royal Norwegian Tactical Flying Squadron, as a lead organization where the members are squadrons. On the right side, the Army Winter Warfare School is the OPR and the lead organization where members are Army battalions.

Figure 38. NPRN Example Service OPRs²⁶³

The lead organizations are major PR and SERE resource providers. Their primary focus is on service tactical squadrons and battalion-size units. The lead organizations also have the primary responsibility for PR and SERE education and training and as such are central to the NPRN in maintaining PR and SERE knowledge and competence. The primary governance responsibility of the service's lead organizations is the management *in* networks, in contrast to the NAO's management *of* networks.²⁶⁴ Though the focus of governance is *in* the NPRN network, each service's lead organization must also address the management *of* their internal service network.

²⁶³ Prototype model built by the author. Governance models adapted from Kenis and Provan found in Milward and Provan, *Manager's Guide*, 22.

²⁶⁴ Milward and Provan, *Manager's Guide*, 19.

3. Self-Governance (Tactical Unit Level)

The PR officer or the senior SERE instructor is the NPRN network node that is the link to the self-governed network at the unit or squadron level and all unit PR-trained individuals. The self-governance option is also called shared governance or participant governance and illustrated in Figure 39.

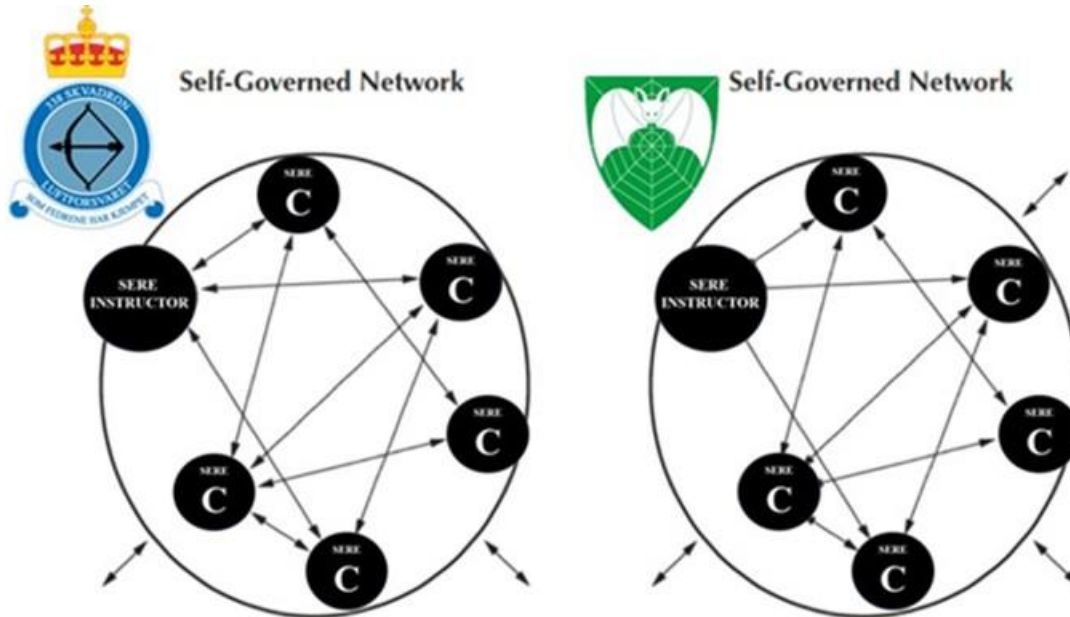

On the left side, the figure shows the RNoAF 338 squadron and its members at the tactical level. On the right is the Army Intelligence battalion.

Figure 39. Air Force and Army Unit-Level Self-Governance²⁶⁵

The NPRN participants at the tactical level have the best possibility to see pop-up PR and SERE education and training events at their local unit, as well as finding the best way to integrate the annual PR and SERE training requirement into daily training.

4. NPRN Governance and the Network Design Continuum

To conceptualize how the prototype governance model fits in the network design continuum, I have merged the two models. In Figure 40, I have placed the NPRN

²⁶⁵ Prototype model built by the author. Governance models adapted from Kenis and Provan found in Milward and Provan, *Manager's Guide*, 22.

prototype onto Roberts’ design continuum to show how each governance type relates to four dimensions of network design.

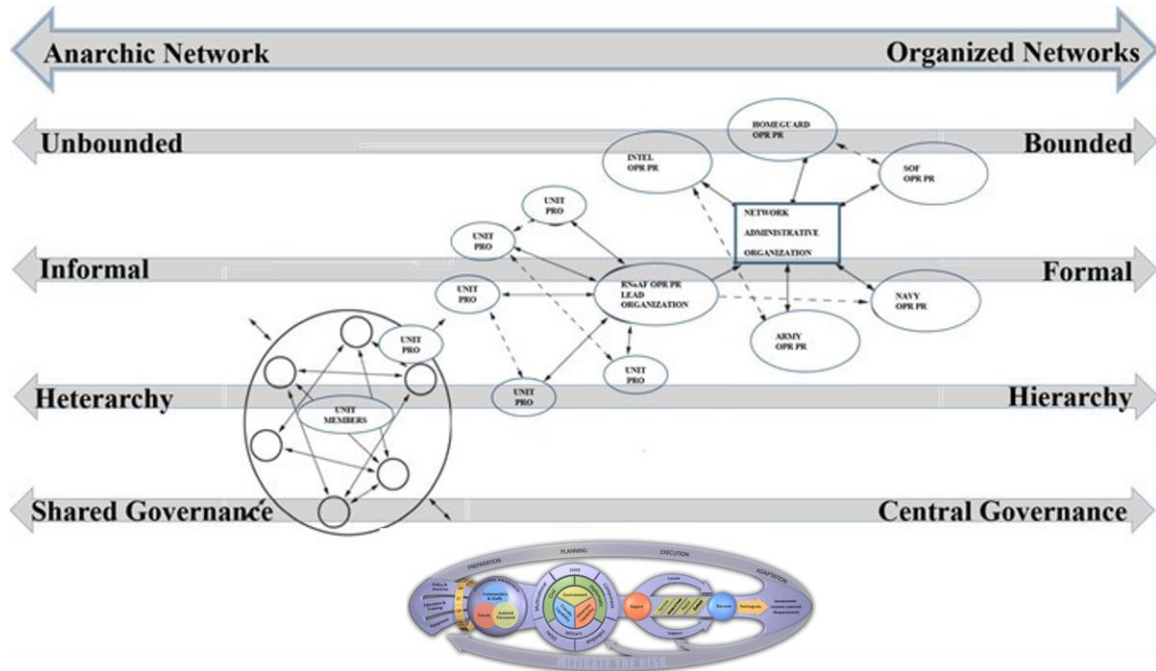

Figure 40. NPRN Governance from Joint to Individual and Strategic to Tactical²⁶⁶

Figure 40 illustrates the merging of Roberts’s concept of the network design continuum with Kenis and Provan’s work on alternative forms of network governance. The NAO is placed to the right on the continuum where membership is more formal and bounded to the key PR network actors at the strategic and service levels plus key network nodes. Interactions are more formal, and coordination is through a hierarchical network structure of nodes. The centralized decision-making form resonates with what Kenis and

²⁶⁶ Prototype model built by the author. (Governance models adapted from Kenis and Provan found in Milward and Provan, *Manager’s Guide*, 22; and network design continuum found in Nancy Roberts, “Design Continuum Analysis Tool” [PowerPoint presentation, Network Design course, Naval Postgraduate School, Monterey, California, 2015].)

Provan state as the advantages of the NAO form, which is the efficiency of day-to-day management, the strategic involvement by key members, and its sustainability.²⁶⁷

To mitigate what Kenis and Provan state as the disadvantages of the NAO, the “perception of hierarchy, cost of operation, complex administration,”²⁶⁸ the NPRN governance prototype delegates the responsibility for network management at the service level to each of the service OPR PR, as illustrated by the RNoAF OPR PR in Figure 40. The services’ lead organizations also have a core membership, but they are better positioned to decide on network membership than the NAO because they have a better visibility and flexibility to identify and collaborate with a more diverse group of network members who serve the network purpose. The services’ OPRs also make centralized decisions, and their advantage is, according to Kenis and Provan, “efficiency [and] clear network direction.”²⁶⁹

The shared governance form might mitigate what Kenis and Provan state as the lead organization’s problems of “domination by lead organization, lack of commitment by members.”²⁷⁰ By opting for a shared governance structure at the tactical level, it is up to all members to include and pursue both ideas and members whom they see fit for their own network at the local level. The link to the hierarchy of the service OPR and the NAO is maintained by the PRO or SERE instructor as a trusted network agent who represents the NPRN.

In sum, the NPRN governance model’s intent is to exploit the advantages of each form of network governance while mitigating the disadvantages. As Kenis and Provan state, “None of these structures turns out to be universally superior. Rather, we argue here that each form has its own particular functionality or, in other words, each differs in what it can do well.”²⁷¹

²⁶⁷ Milward and Provan, *Manager’ Guide*, 22.

²⁶⁸ Ibid.

²⁶⁹ Ibid.

²⁷⁰ Ibid.

²⁷¹ Kenis and Provan, “Towards an Exogenous Theory,” 446.

5. Management *of* and *in* Networks

For the NPRN to operate efficiently, it will be essential for the prototype that the work process of managing the network is addressed by the NAO and the services' OPRs. For the governance model to succeed, the nuance of management *of* network and *in* networks must be addressed properly. In Figure 41, Milward and Provan provide five essential management tasks that differ depending on whether one focuses on management *of* networks or *in* networks.

Essential Network Management Tasks	Management of Networks	Management in Networks
Management of Accountability	<ul style="list-style-type: none"> • Determining who is responsible for which outcomes. • Rewarding and reinforcing compliance with network goals. • Monitoring and responding to network “free riders.” 	<ul style="list-style-type: none"> • Monitoring your organization’s involvement in the network. • Ensuring that dedicated resources are actually used for network activities. • Ensuring that your organization gets credit for network contributions. • Resisting efforts to “free ride.”
Management of Legitimacy	<ul style="list-style-type: none"> • Building and maintaining legitimacy of the network concept, network structures, and network involvement. • Attracting positive publicity, resources, new members, tangible successes, etc. 	<ul style="list-style-type: none"> • Demonstrating to others (members, stakeholders) the value of network participation. • Legitimizing the role of the organization among other network members.
Management of Conflict	<ul style="list-style-type: none"> • Setting up mechanisms for conflict and dispute resolution. • Acting as a “good faith” broker. • Making decisions that reflect network-level goals and not the specific interests of members. 	<ul style="list-style-type: none"> • Working at the dyad level to avoid and resolve problems with individual network members. • Working inside your organization to act as a “linking pin” to balance organization versus network demands and needs.
Management of Design (Governance Structure)	<ul style="list-style-type: none"> • Determining which structural governance forms would be most appropriate for network success. • Implementing and managing the structure. • Recognizing when structure should change based on network and participant needs. 	<ul style="list-style-type: none"> • Working effectively with other network participants and with network-level management, based on the governance structure in place. • Accepting some loss of control over network-level decisions.
Management of Commitment	<ul style="list-style-type: none"> • Getting the “buy-in” of participants. • Working with participants to ensure they understand how network success can contribute to the organization’s effectiveness. • Ensuring that network resources are distributed equitably to network participants based on network needs. • Ensuring that participants are well informed about network activities. 	<ul style="list-style-type: none"> • Building commitment within the organization to network-level goals. • Institutionalizing network involvement so that support of network goals and participation goes beyond a single person in the organization.

Figure 41. Management of and in Networks²⁷²

Each of the five essential tasks, management of accountability, management of legitimacy, management of conflict, management of design, and finally management of commitment, are important aspects to the NPRN. For the NAO, the task is management of networks as it is the reason for its being. That said, the NAO also could be connected to the larger global PR network and be concerned about its participation in a network.

²⁷² Milward and Provan, *Managers’s Guide*, 19.

The service OPRs need not only to provide management *of* their service PR network as a lead organization, but also as an actor *in* network as they collaborate across the service network boundaries.

Built upon the governance structure, the capstone provides a detailed description of the core membership network structure based on the key actors: commanders and staffs, forces, and isolated personnel. This structure is provided in Appendix E.

D. THE NPRN COMMUNITY OF PRACTICE

The NPRN CoP prototype links network members so they can tell their story and create the “personal ties that assure loyalty and trust.”²⁷³ The CoP and its work processes also contribute to create what McChrystal describes as “*Shared Consciousness*—an emergent intelligence that is created by a holistic understanding of the operating environment and a high level of internal connectivity,” and “*trust*—faith in the intent and competence of one’s colleagues.”²⁷⁴ The CoP prototype also operates as a knowledge network to keep the members current on the latest developments in PR.

Theorists of knowledge management highlight the CoPs as essential for the development of a domain of knowledge through member interaction that merges theory with practice and drives the innovation and development of knowledge.²⁷⁵ Three fundamental elements of a CoP are a domain of knowledge (what they know), a community of people who care about this domain (who they are), and a shared practice of this knowledge which for the NPRN is PR (what they do).²⁷⁶ To facilitate the education and training necessary to perform the network roles and tasks, the NPRN prototype calls for a CoP that creates what Anklam labels network “locus.” She further states that “a network must both ‘live’ somewhere and have a repository for its history.”²⁷⁷ The locus

²⁷³ Arquilla and Ronfeldt, *Networks and Netwars*, 324.

²⁷⁴ McChrystal, “What Is Crosslead?”

²⁷⁵ See Etienne Wenger’s work on communities of practice: Etienne Wenger, Richard McDermott, and William M. Snyder, *Cultivating Communities of Practice: A Guide to Managing Knowledge* (Boston: Harvard Business School Press, 2002); and Etienne Wenger-Trayner et al., *Learning in Landscapes of Practice* (New York: Routledge, 2015).

²⁷⁶ Wenger, McDermott, and Snyder, *Cultivating Communities of Practice*, 27.

²⁷⁷ Anklam, *Net Work*, 81.

dimensions are “place, space, and pace—a real place, information space, and interaction pace, or rhythm.”²⁷⁸

1. NPRN Community of Practice Real Place

The physical real place should represent the history of PR in general and the NPRN in particular and support the narrative level, the story being told, which is an important part of an efficient network organization.²⁷⁹ The primary place is where the educational institutions are located, but is also at the unit level where the actors are situated in the day-to-day activity. These places are arenas for a continuous development of knowledge through the interaction of the members of the PR and SERE community of practice.²⁸⁰ In addition, one should both be aware of and utilize the learning arena of the outdoor physical exercise space where the education and training are conducted on a regular basis as an important arena for the development of the PR knowledge in the field. It is recommended that the responsible agency be the services’ PR and SERE training institutions.

a. Create a Physical Place for PR Knowledge and History

To enable the CoP to learn and develop its knowledge and PR skillset and bring forward the PR narrative, a collection of knowledge and history should be made available in both a real and virtual space with which the PR actors can interact while developing their PR situational awareness. Through its discovery phase, this capstone has built an extensive bibliography of PR historic literature as well as official doctrine and academic PR knowledge. A physical place where this knowledge is stored in the form of a PR library that provides PR subject matter experts with a single point of access to PR literature which is not available online. The capstone bibliography can serve as a starting point to build the PR library illustrated by Figure 42 and is listed in Appendix A.

²⁷⁸ Ibid.

²⁷⁹ Arquilla and Ronfeldt, *Networks and Netwars*, 324.

²⁸⁰ Wenger, McDermott, and Snyder, *Cultivating Communities of Practice*.

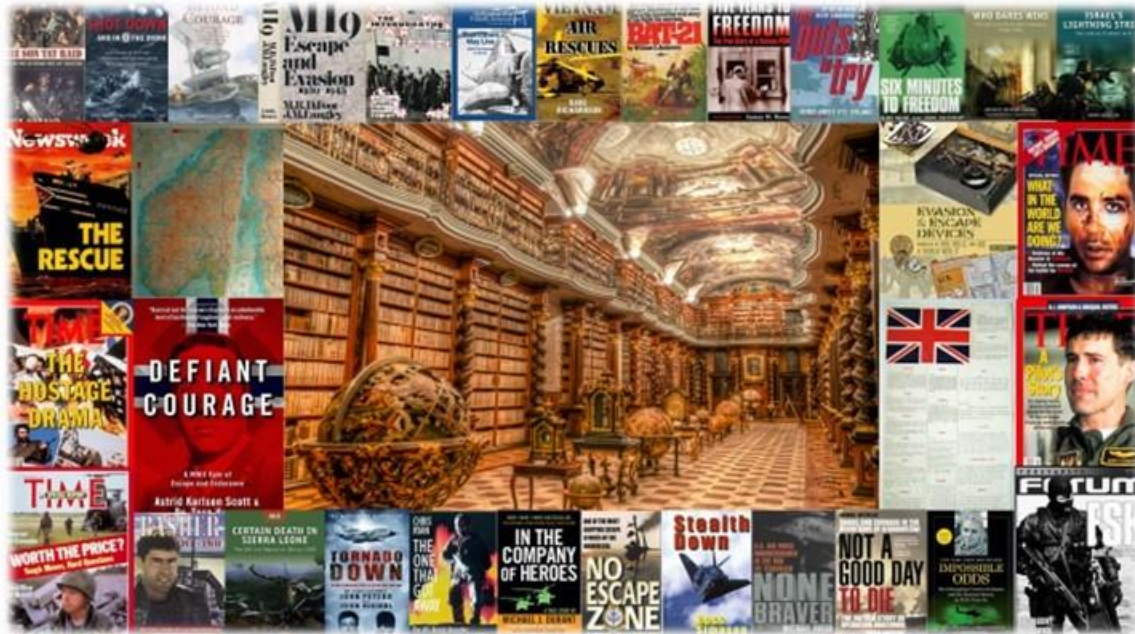

Figure 42. Physical PR Knowledge Space²⁸¹

2. NPRN Community of Practice Virtual Space

To enable an active CoP, the design team highly recommends a virtual space to provide an overview of the network’s activities and various exercises. All NPRN actors should be able to post planned and upcoming opportunities for joint training on the NPRN virtual space webpages, to coordinate and collaborate with all members of the community.

A network as large and as geographically separated as the NPRN needs to have a well-developed “virtual space” with proper Information and Communication Technology (ICT) to support the PR narrative, knowledge creation, and information sharing. The NAO, in collaboration with the services, should be responsible for establishing lead organizations and both an unclassified web page and a classified web page. It should build an online library of relevant PR literature to facilitate the access to PR knowledge and NPRN activities. The virtual space should be made available to as many actors as

²⁸¹ Prototype model built by the author. “Atlases of the Clementinum,” 500px, December 18, 2012: https://500px.com/photo/35988964/atlas-of-the-clementinum-by-sean-yan?ctx_page=1&from=user&user_id=2329539, book covers from Amazon.com and *Time* magazine.

possible in the unclassified space, while at the same time, the distribution of classified material to those with granted access privileges must be managed.

3. NPRN Community of Practice Pace

According to Anklam, the interaction pace of a network balances “connections in both place and space.”²⁸² The intensity and frequency of the network members’ interactions, its pace, and its rhythm, are what enables the membership to synchronize their activities.²⁸³ Since the members consist of several sub-networks, attention to their integration is essential. The most frequent interaction between NPRN members occurs at various PR events. The core NPRN events in peacetime that have the most potential for the integration of core PR actors, commanders and staffs, forces, and isolated personnel and practice in the execution phase, are the services’ SERE level-C certification exercises. Figure 43 illustrates how the NPRN actors and the NAO can provide an overview of the network interaction pace, namely its events, to all participants in the form of a NPRN PR event “wheel.”

²⁸² Anklam, *Net Work*, 88.

²⁸³ *Ibid.*

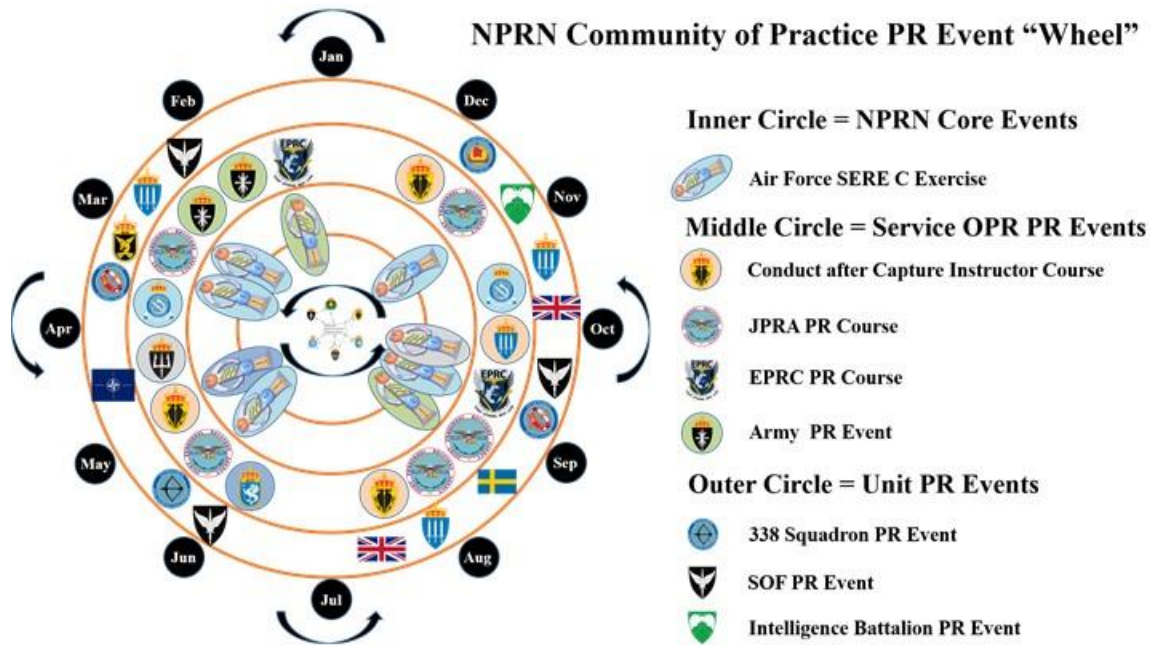

The PR event wheel should be built to display the opportunities that exist to interact between network members, where and when they occur, and how to gain access and participation. The example above illustrates, counterclockwise, events available from January to December and a quick symbol explanation on the right.

Figure 43. NPRN CoP PR Event “Wheel”²⁸⁴

The purpose of the event wheel is to display to all NPRN members PR events where and when there is an opportunity for the CoP to physically interact. The PR wheel should display the aggregate of PR events as they unfold throughout the year and the availability for members to join and to benefit. To maximize PR resources and achieve the most interaction and collaboration, the NAO and the lead organizations should emphasize and maximally make use of planned events to increase the NPRN interaction frequency. Core events are the full-scale PR and SERE exercises, visualized in Figure 43, with the PR model of the execution phase. PR and SERE OPR symbols are smaller scale events, and unit symbols display local events as they are scheduled. The interaction pace, as displayed by the PR event wheel, becomes an important arena for the CoP to meet and develop their knowledge and keep the PR conversation going. Each event becomes an important place to build network ties. The network governance structure should seek to include a diverse CoP at each event.

²⁸⁴ Prototype model built by the author.

Figures 44, 45, and 46 illustrate how the network interaction pace is an important arena for the development of network actors' PR knowledge as they join one of the core PR events, here represented by participating in an RNoAF SERE level-C course.

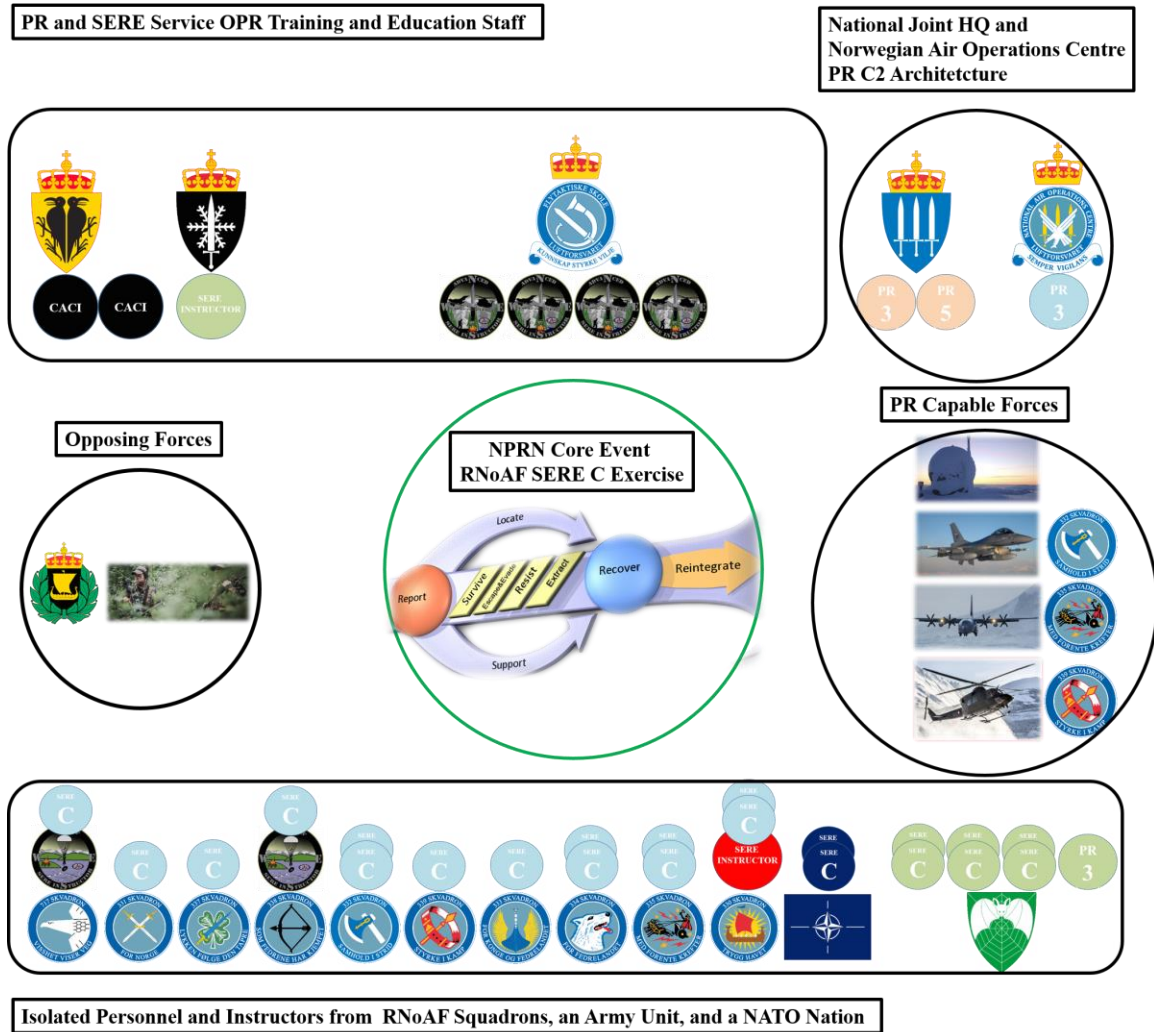
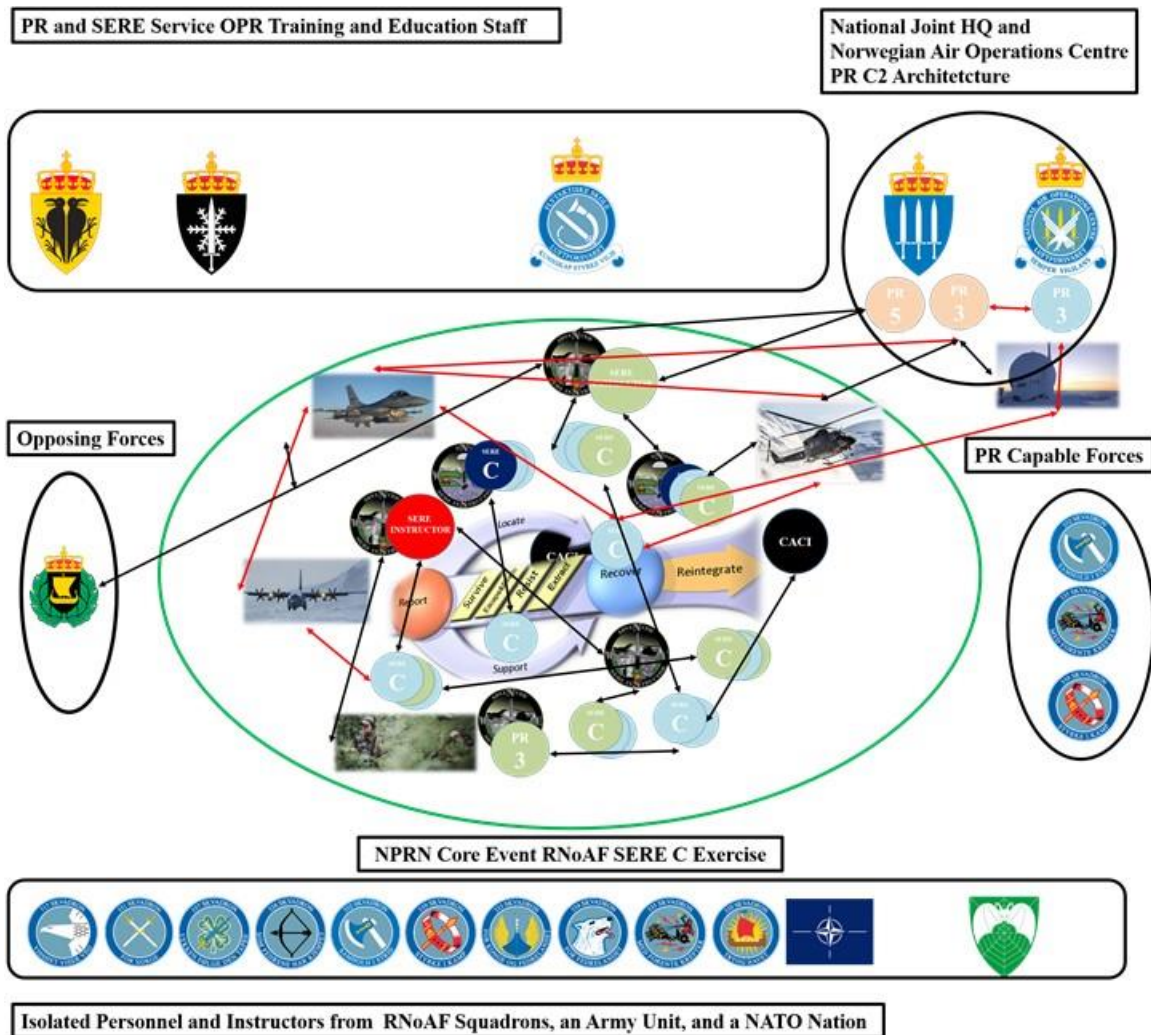

Figure 44 illustrates an example of participants at a NPRN event, represented by a RNoAF SERE level-C course and certification exercise. From top left and clockwise, participants include Conduct after Capture instructors (CACIs), from the Intelligence Service OPR for CAC, SERE instructor from the Army PR and SERE OPR, the RNoAF OPR with its instructor cadre, planners representing the NJHQ and the NAOC, forces from several RNoAF squadrons, isolated personnel from the Army and RNoAF, as well as international participants and squadron SERE instructors. The Home Guard participates and represents enemy forces.

Figure 44. NPRN Example of PR and SERE PACE and CoP²⁸⁵

²⁸⁵ Prototype model built by the author.

Figure 44 illustrates the diversity of PR actors at the beginning of a PR event. Network members are participating from all services and all levels of the PR organization including isolated personnel, forces, and commanders and staffs, as well as the education and training institutions of more than one service. Network governance awareness of the importance of the network pace represented by its interaction events is critical for the CoP's ability to keep PR development going, as these events are their primary meeting place. Figure 45 illustrates the potential to build and expand NPRN connections as the SERE C course unfolds and participants collaborate, in this case, towards a common purpose of producing SERE level-C certified isolated personnel and educating and training commanders and staff, as well as forces.



The NPRN event serves as a key event for many of the various actors in the NPRN to come together, collaborate, hone, and develop PR skills and situational awareness and most important, to build trust and social capital that cross service and hierarchical boundaries.

Figure 45. Communities of Practice: Creating Ties, Trust and Social Capital I²⁸⁶

Figure 46 illustrates new ties created by the interaction and collaboration of the NPRN event.

²⁸⁶ Prototype model built by the author.

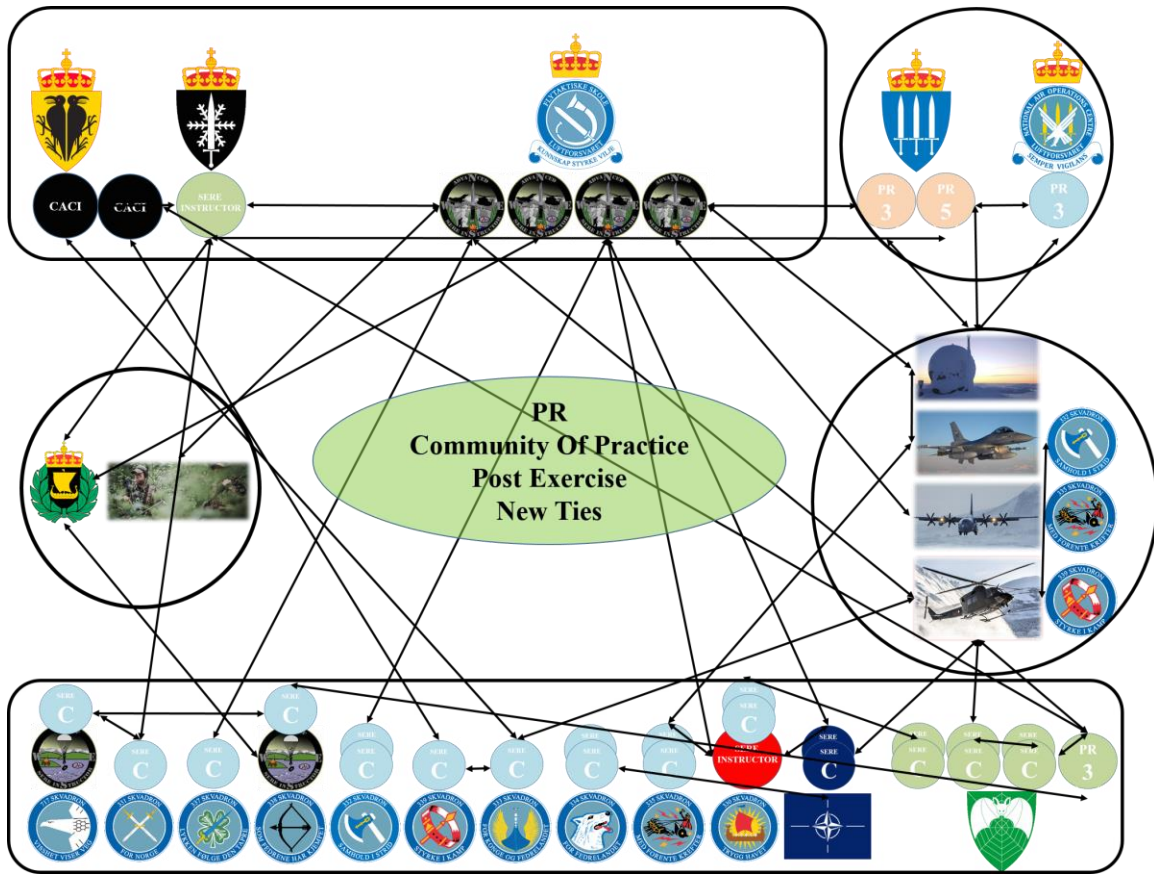

The NPRN event creates new ties between the various PR actors.²⁸⁷

Figure 46. Communities of Practice: Creating Ties, Trust and Social Capital II

There are only limited opportunities available for the NPRN to physically meet and collaborate. Therefore, it is important that the NPRN leadership uses these occasions to their fullest advantage to broaden the interactions with all the network members. Virtual interactions, in addition to the physical interactions in space, also are needed. They can provide PR information and knowledge and through a formal web-based communication system, support the CoP activities and interactions.

E. PROTOTYPE TESTING

Thus far, the iterative process of prototype development and prototype testing has been conducted with the design team and a limited number of Norwegian key PR actors.

²⁸⁷ Prototype model built by the author.

The full and detailed prototyping-testing phase will continue with a larger group when the author returns to Norway. The prototype-testing phase is expected to continue from August to December 2016 as a sponsored project of the RNoAF EA PR.

THIS PAGE INTENTIONALLY LEFT BLANK

VII. CONCLUSION

When we create new things—technologies, organizations, processes, environments, ways of thinking, or systems—we engage in design. To come up with an idea of what we think would be an ideal addition to the world, and give real existence—form, structure, and shape—to that idea, is at the core of design as a human activity.

Harold G. Nelson and Erik Stolterman²⁸⁸

Four brave men who do not know each other will not dare attack a lion. Four less brave, but knowing each other well, sure of their reliability and consequently mutual aid, will attack resolutely.

Ardant du Picq²⁸⁹

A. PERSONNEL RECOVERY FOR VALUE OR VALOR

I began the capstone introduction with four stories that, for me, serve as a telling narrative of what humans are willing to do in order to come to the rescue of a fellow human being. From WWII, the Vietnam War, a crash site in Somalia, and a hostage rescue mission in Kabul, these stories represent numerous other tales of valor. The value our society places on such valor is demonstrated through the awards of the highest honors to those who display acts of altruism in the face of danger to themselves. On February 26, 2016, I quite accidentally got to watch another historic PR event. President Obama presented the Medal of Honor to Navy SEAL Edward C. Byers for his actions in a 2012 hostage rescue in a remote part of Afghanistan that led to the successful recovery of Dr. Dilip Joseph, reuniting him with his family. The successful recovery did not come without a cost, because Nicolas Checque, another SEAL, died in the same operation, at a great loss for his family, colleagues, and friends. As such, the ceremony became both a celebration and recognition of valor and a life saved, but also the remembrance of a life

²⁸⁸ Nelson and Stolterman, *Design Way*, 1.

²⁸⁹ Charles Jean Jacques Ardant du Picq, *Battle Studies: Ancient and Modern* (Harrisburg, PA: Military Service Publishing, 1947), 110.

lost. What made the ceremony even more connected to PR was the fact that two other Medal of Honor recipients were also present. Navy SEAL Tom Norris, who saved Bat-21, the Air Force navigator Icelal “Gene” Hambleton, in Vietnam 1972—the story told in the introduction—was also present. Also present was another SEAL, Mike Thornton, who received his Medal of Honor for the rescue of Tom Norris and became the only Medal of Honor recipient to have rescued another Medal of Honor recipient. In essence, in one room, the history of PR and its value were represented by three living SEALs and three successful recoveries, as well as the cost involved, by the absence of Checque, whose life was lost in a rescue operation.

1. Bigger Ideas

I began the capstone introduction with “Personnel Recovery for Valor or Value,” but after watching the ceremony, it occurred to me there must be something bigger and deeper that motivates people to display such acts of altruism. My studies at NPS have provided many perspectives on warfare, but one class on “Psychological and Anthropological Perspectives on Fairness, Identity, and Terrorism,” taught by Professor Siamak Naficy, suggested that there is more to PR than value or valor that is relevant to this capstone. The anthropology perspective provided a hint at the bigger ideas on why people display such altruistic acts at great risk to themselves. The answer may reside in an evolutionary perspective, as stated by evolutionary biologist David Sloan Wilson, that is an important aspect of the PR narrative: “Selfishness beats altruism within groups. Altruistic groups beat selfish groups. Everything else is commentary.”²⁹⁰

If altruistic group behavior and survival are linked to our existence today and prompt such acts as those seen in PR, then our narrative has to change. Currently there is a growing distance between society and the groups doing the fighting. The division is such that warfighting is outsourced to the professional military as society’s insurance policy. In such a situation, it becomes harder to see the direct link between group altruism and the survival of a society that pays for such altruism as insurance. PR within the

²⁹⁰ David Sloan Wilson and Edward O. Wilson, “Rethinking the Theoretical Foundations of Sociobiology,” *Quarterly Review of Biology* 82, no. 4 (2008): 345.

military can be understood as an extension of that insurance policy as it serves as the military's own insurance policy. But as the direct link between group survival and the forces doing the fighting becomes more tenuous, it becomes harder to understand why we should fund such a force in the first place. This could be one reason why the PR force throughout history has seen so many ups and downs and why its lessons learned are subsequently forgotten between wars.

Today, the PR system is fragmented and consists of many independent groups that need to coordinate to achieve their missions. The PR actors and entities must, like Ardant du Picq's four less brave men, come together, know each other well, and be sure of their reliability and mutual aid in order to act as one.

B. CAPSTONE SOLUTION

At its core, the capstone prototypes and their recommendations are devoted to the design of the NPRN's governance structure with its ability to coordinate and expand its reach to all members, provide expertise and leadership at all levels, and to build relationships that improve network performance.

The NPRN CoP is expected to serve as a repository of PR knowledge and competence. It would be responsible for keeping PR competence alive and making sure the NPRN learns from previous PR mistakes, draws benefits from best practices, and enables adaptations as conditions change. In other words, the CoP retains the learning that people have paid in blood and treasure to acquire.

At the technological level, the information system's design is expected to afford access to all critical actors so they can share PR knowledge and participate in all PR community of practice activities. In addition, the PR CoP's narrative is expected to evolve via the information system to signal PR's important function for its warfighters, the impact it has on the will to fight, and the moral imperative we have to rescue those who become isolated and potentially captured.

Written policy and doctrine, when developed, should provide the NPRN community with clear guidance to commanders and staffs of their responsibilities to

ensure that all critical actors are aware of their role in the PR system and provide necessary support during peacetime, crisis, and war.

C. DESIGN PROCESS AND CAPSTONE APPLICABILITY

A design philosophy approaches the love of wisdom as a devotion to the *reconstitution of sophia*—in other words, the reunification of *inquiry* and *action*, or more specifically, *inquiry for action*. Actions creating the right thing, for the right people, at the right time, in the right place, in the right way, for the right reasons is design wisdom.

—Harold G. Nelson and Erik Stolterman²⁹¹

1. Design Process

It was difficult to adhere strictly to the Design Thinking model which calls for a close collaboration among a core design team of diverse members who meet in person for each phase of the process. Despite several travels to Norway to meet the other members of the team, the geographical distance and a nine-hour time difference between Norway and NPS did hamper communication. Therefore, as the lead for the project, I had to synthesize inputs and make many of the design decisions.

The challenges of communication experienced during this capstone are likely to be similar to other projects that find it difficult to gather team members in the same place at the same time, especially for those projects that have a diverse cross-disciplinary team located in different organizations. Despite this limitation and the less than perfect conditions, I nonetheless would recommend design as an inquiry for action to be taught to a broader audience of future leaders at NPS and elsewhere. It was possible to develop work-arounds to adjust for the time delays and distance, which did not substantively affect the development of the prototypes and hamper movement through at least four of the five phases of the design process.

²⁹¹ Nelson and Stolterman, *Design Way*, 217.

2. Capstone Applicability

This capstone has proposed the creation of a cross-boundary network, the design of its governance structure, and the development of a community of practice to support the NPRN activities. These prototypes, if successfully tested and implemented, will have the ability to cross traditional service boundaries and link hierarchical silos. They also have the advantage of being empowered by the traditional hierarchy while at the same time taking advantage of the flexibility that a network affords.

For the NPRN specifically, the prototypes offer advantages, not the least which is the preparation of network members to participate in any PR activity either as Norwegians or as members of any NATO or a U.S.-led coalition. By creating a shared understanding of the PR network, its functions and tasks, PR actors will be better prepared to coordinate and work together when they deploy.

3. Areas for Future Studies

I believe these prototypes are applicable to other professional organizations, although follow-on research would need to establish their applicability in other areas besides PR and in other military organizations. The study of how to build communities of practice in the military and how to manage the development of knowledge, skill, and competence also are important for many knowledge areas in the military, such as forward air controllers, medics, operators, and subject matter experts in other fields.

The NPRN participants in the NAO and lead organizations will benefit from further study of the management *in* networks and the management *of* networks. As our world becomes more networked, we need to understand how to lead, design, and manage these connections. This capstone is one step in that direction.

THIS PAGE INTENTIONALLY LEFT BLANK

APPENDIX A. PR BIBLIOGRAPHY

A. INTRODUCTION

The following chronological bibliography of PR-related literature is the result of a human-centered approach to the topic of PR over the time frame from WWII to the present day. The method of using the Design Thinking approach to this capstone and the initial Discovery phase calls for a human-centered approach in the effort to understand the needs of the people involved. I have had this in mind, and the result is the following list of PR-related literature, chronologically grouped. The list covers the abstract theoretical perspective as a baseline with empirical cases studies on PR and includes the individual actor-specific literature of the people involved. The chosen literature, in each time period, is a result of the author's effort to understand and gain insight from various groups to include (or, "with special emphasis on") the isolated personnel who have had to survive, escape, and evade the enemy, and who in many cases, endured captivity and resisted interrogation and enemy POW treatment when the rescue forces were not able to get them out of harm's way. To gain insight into the challenges faced by rescue forces, I have sought insights from the wide variety and types of rescue forces involved. To understand the commanders and staffs of rescue operations, their perspective was also sought where available. In addition to the education and training effort of these groups of people, both technological and organizational doctrinal descriptions and development are also listed as they evolved through time.

B. RELEVANT ABSTRACT THEORY

Arquilla, John. *Worst Enemy: The Reluctant Transformation of the American Military*. Chicago: Ivan R. Dee, 2008.

Krepinevich, Andrew, and Barry Watts. *The Last Warrior: Andrew Marshall and the Shaping of Modern American Defense Strategy*. New York: Basic Books, 2015.

Posen, Barry R. *The Sources of Military Doctrine: France, Britain, and Germany between the World Wars*. London: Cornell University Press, 1984.

Rosen, Stephen Peter. *Winning the Next War: Innovation and the Modern Military*. London: Cornell University Press, 1991.

Van Creveld, Martin. *Technology and War: From 2000 B.C. to the Present*. New York: The Free Press, 1991.

Van Creveld, Martin. *The Transformation of War*. New York: The Free Press, 1991.

Williamson, Murray, and Allan R. Millett. *Military Innovation in the Interwar Period*. Cambridge: Cambridge University Press, 1996.

C. CASE STUDIES AND PR ACTOR–SPECIFIC LITERATURE

a. 1939–1945, World War II

Military Doctrine

Air Ministry. *Health Hints for Warm Climates*. A.M. Pam 160. London: Air Ministry, 1943.

Department of the Air Force. *Survival*. AFM 64-5. Washington, DC: Air Training Command, 1945.

Headquarters Army Air Forces. *Emergency Uses of the Parachute*. AAF Manual No. 60-1. Washington, DC: Headquarters Army Air Forces, 1945.

Headquarters Army Air Forces. *Survival: On Land Jungle-Desert-Arctic*. AAF Manual No. 21W. New York: Army Air Forces Tactical Center, 1944.

Headquarters Army Air Forces. *Survival: On Land Jungle-Desert-Arctic*. AAF Manual 64-0-1. New York: Headquarters Army Air Forces, 1945.

Office of the Chief of Naval Operations. *How to Survive on Land and Sea*. Annapolis, United States Naval Institute, 1943.

Office of Naval Intelligence. *Survival on Land and Sea*. Washington, DC: Government Printing Office, 1943.

Office of Naval Intelligence. *Survival on Land and Sea*. NAVAER 13-1-501. Washington, DC: Government Printing Office, 1944.

War Department. *If You Should be Captured, These Are Your Rights*. Pamphlet 20-10. Washington, DC: Government Printing Office, 1944.

War Department. *Norwegian: A Guide to the Spoken Language*. TM 30-310. Washington, DC: Government Printing Office, 1943.

War Department. *Norwegian Phrase Book*. TM 30-610. Washington, DC: Government Printing Office, 1943.

War and Navy Departments. *A Pocket Guide to Netherlands East Indies*. Washington, DC: Government Printing Office, 1944.

Royal Air Force (RAF) & Army Air Force (AAF) Air Sea Rescue

Bungay, Stephen. *The Most Dangerous Enemy: A History of the Battle of Britain*. London: Aurum Press, 2000.

Franks, Norman. *Another Kind of Courage: Stories of the UK-Based Walrus Air-Sea Rescue Squadrons*. London: Patrick Stephens, 1994.

Franks, Norman. *Beyond Courage: Air Sea Rescue by Walrus Squadrons in the Adriatic, Mediterranean, and Tyrrhenian Seas 1942–1945*. London: Grub Street, 2003.

Galdorisi, George, and Tom Phillips. *Leave No Man Behind: The Saga of Combat Search and Rescue*. Minneapolis: Zenith Press, 2008.

Keeney, L. Douglas. *Air-Sea Rescue 1941–1952*. Campbell: Premiere, 2013.

Pitchfork, Graham. *Shot Down and in the Drink: True Stories of RAF and Commonwealth Aircrews Saved from the Sea in WWII*. Richmond: The National Archives, 2005.

Sutherland, Jon, and Diane Canwell. *The RAF Air Sea Rescue Service 1918–1986*. Barnsley: Pen & Sword Aviation, 2005.

UK Military Intelligence 9 (MI9)

Baldwin, R. E. *Behind Enemy Lines: Evasion and Escape Aids of World War II*. San Antonio: Elm Grove, 2012.

Baldwin, R. E., and Thomas McGarry. *Last Hope: The Blood Chit Story*. Atglen, PA: Schiffer, 1997.

Doll, John G. *Cloth Maps, Charts and Blood Chits of World War II*. Bennington, VT: Merriam Press, 1988.

Foot, M. R. D., and J. M. Langley. *MI9 Escape and Evasion 1939–1945*. London: The Bodley Head, 1979.

From, Phil. *Evasion & Escape Devices: Produced by MI9, MIS-X, and SOE in World War II*. Atglen, PA: Schiffer, 2015.

Hutton, Clayton. *Official Secret: The Remarkable Story of Escape Aids—Their Invention, Production—and the Sequel*. New York: Crown, 1961.

Hutton, Clayton. *Per Ardua Libertas*. London: War Office, 1942.

Langley, J. M. *Fight Another Day*. London: Collins, 1974.

Neave, Airey. *Saturday at MI-9: The Classic Account of the World War Two Allied Escape Organisation*. Barnsley: Pen and Sword Books, 2004.

War Office. *Attachment "A": Historical Record of MI9*. London: General Staff, 1945.

War Office. *Attachment "G", History of I.S.9 W.E.A.* London: General Staff, 1945.

War Office. *Enclosure I: Historical Record of IS9*. London: General Staff, 1945.

War Office. *Enclosure II: Historical Record of RAF Intelligence Course "B."* London: General Staff, 1945.

War Office. *MI9 Bulletin*. Copy 703. London: General Staff, 1945.

War Office. *MI9 Evasion Reports*. London: General Staff, 1945.

U.S. Military Intelligence Service-X (MIS-X)

Shoemaker, Lloyd R. *The Escape Factory: The Story of MIS-X, The Super-Secret U.S. Agency behind World War II's Greatest Escapes*. New York: St. Martin's Press, 1990.

War Department. *MIS-X Manual on Evasion, Escape, and Survival*. Washington, DC: War Department, 1944.

Special Duties Squadrons

Jackson, Robert. *The Secret Squadrons: Special Duty Units of the RAF and USAAF in the Second World War*. London: Robson Books, 1983.

Verity, Hugh. *We Landed by Moonlight: Secret RAF Landings in France, 1940–1944*. Wilmslow, England: AirData, 1995.

Escape and Evasion (E&E) Networks

Brome, Vincent. *The Way Back: The Story of Lieut.-Commander Pat O'Leary G.C., D.S.O., R.N.* London: Casel and Company, 1957.

Dumais, Lucien. *The Man Who Went Back*. London: Leo Cooper, 1975.

Hæstrup, Jørgen. *Europe Ablaze: An Analysis of the History of the European Resistance Movements 1939–45*. Odense, Denmark: Odense University Press, 1978.

Hemingway-Douglas, Reanne, and Don Douglas. *The Shelbourne Escape Line: Secret Rescues of Allied Aviators by the French Underground, the British Royal Navy, and London's MI9*. Anacortes, WA: Cave Art Press, 2014.

Neave, Airey. *Little Cyclone*. London: Hodder and Stoughton, 1954.

Richards, Brooks. *Secret Flotillas, Volume I: Clandestine Sea Operations to Brittany 1940–1944*. Barnsley, England: Pen & Sword, 2012.

Richards, Brooks. *Secret Flotillas, Volume II: Clandestine Sea Operations in the Western Mediterranean, North African & the Adriatic 1940–1944*. Barnsley, England: Pen & Sword, 2013.

Escape and Evasion (E&E) Europe

Caine, Philip D. *Aircraft Down!: Evading Capture in WWII Europe*. Washington, DC: Brassey's, 1997.

Crawley, Aidan. *Escape from Germany*. New York: Dorset Press, 1985.

Evans, A. J. *The Escaping Club*. Harmondsworth, England: Penguin Books, 1939.

Freeman, Gregory A. *The Forgotten 500: The Untold Story of the Men Who Risked All for the Greatest Rescue Mission of World War II*. New York: NAL Calibel, 2007.

Neave, Airey. *They Have Their Exits*. Barnsley, England: Leo Cooper, 2002.

Nichol, John, and Tony Rennell. *Home Run: Escape from Nazi Europe*. London: Penguin Books, 2007.

Pitchfork, Graham. *Shot Down and on the Run: True Stories of RAF and Commonwealth Aircrews of WWII*. Richmond, VA: The National Archives, 2003.

Escape and Evasion (E&E) Asia

Heimann, Judith M. *The Airmen and the Headhunters: A True Story of Lost Soldiers, Heroic Tribesmen, and the Unlikeliest Rescue of World War II*. Orlando, FL: Harcourt, 2007.

Hill, Richard Vernon. *My War with Imperial Japan: Escape and Evasion*. New York: Vantage Press, 1989.

Keeney, L. Douglas. *Lost in the Pacific: Epic Firsthand Accounts of WWII Survival against Impossible Odds*. Campbell, CA: Premiere, 2014.

Lukacs, John D. *Escape from Davao: The Forgotten Story of the Most Daring Prison Break of the Pacific War*. New York: NAL Caliber, 2010.

Van der Post, Laurens. *The Night of the New Moon*. London: The Hogarth Press, 1970.

Escape and Evasion (E&E) “Moral” Clubs

- Bishop, Edward. *The Guinea Pig Club*. London: Macmillan & Co, 1963.
- Bishop, Edward. *McIndoe’s Army: The Story of the Guinea Pig Club and its Indomitable Members*. London: Grub Street, 2001.
- Bowman, Gerald. *Jump For It!: Stories of the Caterpillar Club*. London: Evans Brothers, 1955.
- Mayhew, E. R. *The Reconstruction of Warriors*. London: Greenhill Books, 2004.
- Neal, John A. *Bless You, Brother Irvin: The Caterpillar Club Story*. Ontario: General Store, 2005.
- Pateman, Colin. *Goldfish, Caterpillar & Guinea Pigs: Accounts of Pilots and Air Crews from the Second World War*. Oxford: Fonthill Media, 2012.

Conduct after Capture (CAC)

- Couch, Jon. *Caged Heroes: American POW Experiences from the Revolutionary War to the Present*. Bloomington, IN: AuthorHouse, 2011.
- Davies, S. J. *In Spite of Dungeons*. London: Hodder and Stoughton, 1954.
- Toliver, Raymond F. *The Interrogator: The Story of Hanns Scharff, Luftwaffe’s Master Interrogator*. Fallbrook, CA: Aero, 1978.

Special Operations Forces (SOF) Escapes and Rescues

- Forczyk, Robert. *Rescuing Mussolini: Gran Sasso 1943*. Oxford: Osprey, 2010.
- Ford, Ken. *The Cockleshell Raid Bordeaux 1942*. Oxford: Osprey, 2010.
- McRaven, William H. *Spec Ops, Case Studies in Special Operations Warfare: Theory and Practice*. Novato, CA: Presidio Press, 1995.
- Rees, Quentin. *Cockleshell Heroes: The Final Witness*. Gloucestershire, England: Amberley, 2010.
- Rottman, Gordon L. *The Cabanatuan Prison Raid: The Philippines 1945*. Oxford: Osprey, 2009.
- Rottman, Gordon L. *The Los Banos Prison Camp Raid: The Phillipines 1945*. Oxford: Osprey, 2010.

Special Operations Executive (SOE)

Foot, M. R. D. *SOE in France: An Account of the Work of the British Special Operations Executive in France 1940–1944*. London: HSMO, 1966.

Howarth, David. *The Shetland Bus: A WWII Epic of Escape, Survival, and Adventure*. Guilford, CT: The Lyon Press, 2001.

Howarth, David. *We Die Alone: A WWII Epic of Escape and Endurance*. Guilford, CT: The Lyon Press, 1999.

Sælen, Frithjof. *Shetlands-Larsen*. Oslo: J.W. Eides Forlag, 1947.

Scott, Astrid Karlsen, and Tore Haug. *Defiant Courage: A WWII Epic of Escape and Endurance*. New York: Skyhorse, 2010.

Poulsen, Jens-Anton. *The Heavy Water Raid: The Raid for the Atom Bomb 1942–1944*. Oslo: Orion Forlag, 2009.

Office of Strategic Services (OSS)

Lineberry, Cate. *The Secret Rescue: An Untold Story of American Nurses and Medics Behind Nazi Lines*. New York: Little, Brown and Company, 2013.

Waller, Douglas C. *Wild Bill Donovan: The Spymaster Who Created the OSS and Modern American Espionage*. New York: Free Press, 2011.

b. 1950–1953, The Korean War

Military Doctrine

Air Ministry. *Arctic Survival*. A.M. Pam 226. London: Air Ministry, 1953.

Air Ministry. *Arctic Survival*. A.M. Pam 226. London: Air Ministry, 1963.

Air Ministry. *Jungle Survival*. A.M. Pam 214. London: Air Ministry, 1950.

Air Ministry. *Sea Survival*. A.M. Pam 224. London: Air Ministry, 1951.

Arctic, Desert, Tropic Information Center. *999 Survived: Survival Experiences in the Southwest Pacific*. ADTIC Publication No. T-100. Montgomery, AL: Air University, 1950.

Arctic, Desert, Tropic Information Center. *Afoot in the Desert: A Contribution to Basic Survival*. ADTIC Publication No. D-100. Montgomery, AL: Air University, 1951.

Arctic, Desert, Tropic Information Center. *It's The Little Things: Evasion and Escape during World War II (S)*. ADTIC Publication No. G-100. Montgomery, AL: Air University, 1950.

Arctic, Desert, Tropic Information Center. *Sun, Sand and Survival: An Analysis of Desert Survival Experiences during WWII*. ADTIC Publication No. D-102. Montgomery, AL: Air University, 1953.

Department of the Army. *Behind Enemy Lines*. DA Pam 21-46. Washington, DC: U.S. Government Printing Office, 1951.

Department of the Air Force. *Survival*. AFM 64-5. Washington, DC: Air Training Command, 1952.

Department of the Air Force. *Survival*. AFM 64-5. Washington, DC: Air Training Command, 1954.

Air-Sea Rescue

Kirkland, Richard C. *MASH Angels: Tales of an Air-Evac Helicopter Pilot in the Korean War*. Short Hills, NJ: Burfors Books, 2009.

Marion, Forrest L. *That Others May Live: USAF Air Rescue in Korea*. San Bernadino, CA: Air Force History and Museums Program, 2004.

Escape and Evasion (E&E)

Blair, Clay. *Beyond Courage: Daring Escapes of Captured Airmen in the Korean War*. New York: David McKay Company, 1955.

Farrar-Hockley, Anthony. *The Edge of the Sword*. London: Frederick Muller, 1954.

Special Operations Forces (SOF)

Jorgenson, Kregg P. J. *MIA Rescue: LRRPs in Cambodia*. New York: Ballantine Books, 1995.

Malcom, Ben S., and Ron Martz. *White Tigers: My Secret War in Korea*. Washington, DC: Brassey's, 1996.

Millar, Ward M. *Airman Down: The Capture and Escape of a U.S. Air Force Pilot*. San Bernadino, CA: CreateSpace, 2015.

Werrell, Kenneth P. *Sabres over Mig Alley: The F-86 and the Battle for Air Superiority in Korea*. Annapolis, MD: Naval Institute Press, 2005.

Conduct after Capture (CAC)

Brown, James A. C. *Techniques of Persuasion: From Propaganda to Brainwashing*. London: Penguin Books, 1963.

Kinkead, Eugene. *Why They Collaborated*. London: Longmans, 1959.

Quinn, Patrick V. *POW Korea: A Memoir*. San Bernadino, CA: CreateSpace, 2012.

Roberts, Lloyd L. *Korea: One Pow's Story*. Huntington Beach, CA: CreateSpace, 2014.

Secretary of Defense Advisory Committee on Prisoners of War. *POW: The Fight Continues After the Battle*. Washington, DC: U.S. Government Printing Office, 1955.

White, William Lindsay. *The Captives of Korea: An Unofficial White Paper of the Treatment of War Prisoners*. New York: Charles Scribner's Sons, 1957.

Worden, William L. *General Dean's Story*. New York: The Viking Press, 1954.

c. 1961–1973, The War in South East Asia: Vietnam and Laos

Military Doctrine

Air Ministry. *Sea Survival*. A.M. Pam 224. 2nd ed. London: Air Ministry, 1957.

Department of the Air Force. *Survival*. AFM 64-5. Washington, DC: Air Training Command, 1962.

Department of the Air Force. *Survival: Search and Rescue*. AFM 64-5. Washington, DC: Air Training Command, 1969.

Department of the Air Force. *Survival Training Edition*. AFM 64-3. Washington, DC: Air Training Command, 1956.

Department of the Air Force. *Survival Training Edition*. AFM 64-3. Washington, DC: Air Training Command, 1962.

Department of the Air Force. *Survival Training Edition*. AFM 64-3. Washington, DC: Air Training Command, 1969.

Department of the Air Force, the Army, and the Navy. *Joint Worldwide Evasion and Escape Manual*. FM 21-77A. Washington, DC: Department of the Air Force, the Army, and the Navy, 1967.

Department of the Army. *Evasion and Escape*. FM 21-77. Washington, DC: U.S. Government Printing Office, 1958.

Department of the Army. *Evasion and Escape*. FM 21-77A. Washington, DC: U.S. Government Printing Office, 1959.

Department of the Army. *Evasion and Escape*. FM 21-77. Washington, DC: U.S. Government Printing Office, 1965.

Department of the Army. *Survival*. FM 21-76. Washington, DC: U.S. Government Printing Office, 1957.

Department of the Army. *Survival, Evasion, and Escape*. FM 21-76. Washington, DC: U.S. Government Printing Office, 1963.

Department of the Army. *Survival, Evasion, and Escape*. FM 21-76. Washington, DC: U.S. Government Printing Office, 1969.

Department of the Army, the Air Force, and the Navy. *Wartime Search and Rescue*. AR 525-90/AFM 64-3/NWP 19-2. Washington, DC: Government Printing Office, 1971.

Department of Defense. *Training and Education Measures Necessary to Support the Code of Conduct (CoC)*. DOD Directive 1300.7. Washington, DC: Department of Defense, 1964.

Royal Canadian Air Force. *Down but Not Out*. Ottawa, Ontario: Survival Training School, 1961.

Combat Search and Rescue (CSAR)

Anderson, William C. *Bat-21*. Englewood Cliffs, NJ: Prentice-Hall, 1980.

Fields, Kenny Wayne. *The Rescue of Streetcar 304: A Navy Pilot's Forty Hours on the Run in Laos*. Annapolis, MD: Naval Institute Press, 2007.

Hukee, Byron E. *USAF and VNAF A-1 Skyraiders Units of the Vietnam War*. Oxford: Osprey, 2013.

Jackson, Mike, and Tara Dixon-Engel. *Naked in Da Nang: A Forward Air Controller in Vietnam*. St. Paul, MN: Zenith Press, 2004.

Marrett, George J. *Cheating Death: Combat Air Rescues in Vietnam and Laos*. New York: Smithsonian Books, 2006.

Taylor, L. B. *That Others May Live: The Aerospace Rescue and Recovery Service*. New York: E.P. Dutton & Co., 1967.

Tilford, Earl H. *The United States Air Force: Search and Rescue in Southeast Asia*. Washington, DC: Center for Air Force History, 1992.

Richardson, Dave. *Vietnam Air Rescues*. San Bernadino, CA: Dave Richardson, 2010.

Whitcomb, Darrel D. *The Rescue of Bat 21*. Annapolis: Naval Institute Press, 1998.

Escape and Evasion (E&E)

Dengler, Dieter. *Escape from Laos*. San Rafael, CA: Presidio Press, 1979.

Henderson, Bruce. *Hero Found: The Greatest POW Escape of the Vietnam War*. New York: Harper, 2010.

Special Operations Forces (SOF) Prisoner of War (POW) Rescues

Dockery, Kevin. *Operation Thunderhead: The True Story of Vietnam's Final POW Rescue Mission and the Last Navy SEAL Killed in Country*. New York: Berkley Caliber, 2008.

Gargus, John. *The Son Tay Raid: American POWs in Vietnam Were Not Forgotten*. College Station, TX: Texas A&M University Press, 2007.

Schemmer, Benjamin F. *The Raid: The Son Tay Prison Rescue Mission*. New York: Ballantine, 1976.

Veith, George J. *Code Name Bright Light: The Untold Story of U.S. POW Rescue Efforts during the Vietnam War*. New York: The Free Press, 1998.

Conduct after Capture (CAC)

Alvarez, Everett, and Anthony S. Pitch. *Chained Eagle: The True Heroic Story of Eight-and-One-Half Years as a POW by the First American Shot Down over North Vietnam*. New York: Donald I. Fine, 1989.

Alvarez, Everett, and Samuel Schreiner. *Code of Conduct*. New York: Donald I. Fine, 1991.

Brandt, Ed. *The Last Voyage of USS Pueblo*. New York: Norton and Co, 1969.

Bucher, Lloyd M., and Mark Rascovich. *Bucher: My Story*. New York: Dell, 1970.

Edwards, John S. *American Ex-Prisoners of War Volume III*. Paducah, KY: Turner, 1988.

Gentry, Curt, and Gary Powers. *Operation Overflight: The U-2 Spy Pilot Tells His Story for the First Time*. New York, Tower, 1970.

Hatch, Gardner. *American Ex-Prisoners of War*. Paduca, KY: Turner, 1988.

Robins, Glenn. *The Longest Rescue: The Life and Legacy of Vietnam POW William A. Robinson*. Lexington: The University Press of Kentucky, 2013.

Rowe, James N. *Five Years to Freedom: The True Story of a Vietnam POW*. New York: Ballantine Books, 1971.

Stockdale, James Bond. *A Vietnam Experience: Ten Years of Reflection*. Stanford: Hoover Institution, 1984.

Stockdale, James Bond. *Courage under Fire: Testing Epictetus's Doctrines in a Laboratory of Human Behavior*. Stanford: Hoover Institution, 1993.

Stockdale, James Bond. *Thoughts of a Philosophical Fighter Pilot*. Stanford: Hoover Institution, 1995.

Stockdale, James Bond, and Sybil Stockdale. *In Love & War: The Story of a Family's Ordeal and Sacrifice during the Vietnam Years*. New York: Harper & Row, 1984.

d. 1975, Cambodia: The Mayaguez Incident

Guilmartin, John F. *A Very Short War: The Mayaguez and the Battle of Koh Tang*. College Station, TX: Texas A&M University Press, 1995.

Vandenbroucke, Lucien S. *Perilous Option: Special Operations as an Instrument of U.S. Foreign Policy*. New York: Oxford University Press, 1993.

e. 1976, Uganda: Operation Thunderbolt

Special Operations Forces (SOF) Rescue

Dunstan, Simon. *Israel's Lightning Strike: The Raid on Entebbe 1976*. Oxford: Osprey, 2009.

Betsler, Muki, and Robert Rosenberg. *Secret Soldier: The Incredible True Story of Israel's Greatest Commando*. London: Simon & Schuster, 1996.

f. 1977, Somalia: GSG-9

McNab, Chris. *Storming Flight 181: GSG-9 and the Mogadishu Hijack 1977*. Oxford: Osprey, 2011.

g. 1979–1981, Iran: Operation Eagle Claw

Special Operations Forces (SOF) Rescue

Beckwith, Charlie A., and Donald Knox. *Delta Force*. New York: Dell, 1983.

Bowden, Mark. *Guests of the Ayatollah: The First Battle in America's War with Militant Islam*. New York: Atlantic Monthly Press, 2006.

Griffiths, John C. *Hostage: The History, Facts, & Reasoning behind Hostage Taking*. London: Andre Deutsch, 2003.

Kyle, James H., and John Robert Eidson. *The Guts to Try: The Untold Story of the Iran Hostage Rescue Mission by the On-Scene Desert Commander*. New York: Orion Books, 1990.

Vandenbroucke, Lucien S. *Perilous Option: Special Operations as an Instrument of U.S. Foreign Policy*. New York: Oxford University Press, 1993.

h. 1980 London SAS: Operation Nimrod

Fremont-Barnes, Gregory. *Who Dares Wins: The SAS and the Iranian Embassy Siege 1980*. Oxford: Osprey, 2009.

i. 1989, Panama: Operation Acid Gambit

Special Operations Forces (SOF) Rescue

Muse, Kurt, and John Gilstrap. *Six Minutes to Freedom*. New York: Citadel Press, 2006.

j. 1990–1991, Iraq: Operation Desert Storm

Military Doctrine

Department of the Air Force. *Aircrew Survival*. AFP 64-5. Washington, DC: U.S. Government Printing Office, 1985.

Department of the Air Force. *Volume I: Search and Rescue Survival Training*. AFR 64-4. Washington, DC: U.S. Government Printing Office, 1985.

Department of the Army. *Code of Conduct, Survival, Evasion, Resistance, and Escape (SERE) Training*. AR 350-30. Washington, DC: Department of the Army, 1985.

Department of the Army. *Prisoner of War Resistance*. FM 21-78. Washington, DC: U.S. Government Printing Office, 1981.

Department of the Army. *Survival*. FM 21-76. Washington, DC: U.S. Government Printing Office, 1986.

Department of the Army, the Air Force, and the Navy. *Combat Search and Rescue Procedures*. AR 525-90/AFR 64-3/NWP 19-2. Washington, DC: U.S. Government Printing Office, 1985.

Deputy Secretary of Defense. *Training and Education to Support the Code of Conduct (CoC)*. DOD Directive 1300.7. Washington, DC: Deputy Secretary of Defense, 1988.

Combat Search and Rescue (CSAR)

Atkinson, Rick. *Crusade: The Untold Story of the Persian Gulf War*. New York: Houghton Mifflin Company, 1993.

Nason, Erick W. *From Desert Storm to Iraqi Freedom: One Soldier's Story*. Bloomington, IN: AuthorHouse, 2006.

Whitcomb, Darrel D. *Combat Search and Rescue in Desert Storm*. Montgomery, AL: Air University Press, 2006.

Escape and Evasion (E&E)

Ryan, Chris. *The One That Got Away*. London: Century, 1995.

Conduct after Capture (CAC)

Coburn, Mike. *Soldier Five: The Real Truth about the Bravo Two Zero Mission*. Edinburgh: Mainstream, 2004.

Copeland, Peter. *She Went to War: The Rhonda Cornum Story*. Novato, CA: Presidio Press, 1992.

McNab, Andy. *Bravo Two Zero*. London: Bantam Press, 1993.

Peters, John, and John Nichol. *Tornado Down*. London: Signet, 1993.

Ratcliffe, Peter, Noel Botham, and Brian Hitchen. *Eye of the Storm: Twenty-Five Years in Action with the SAS*. London: Michael O'Mara Books, 2001.

k. 1993, Somalia: Operation Gothic Serpent

Military Doctrine

Department of the Army. *Survival*. FM 21-76. Washington, DC: Department of the Army, 1992.

Special Operations Forces (SOF) Rescue

Bowden, Mark. *Black Hawk Down: A Story of Modern War*. New York: Atlantic Monthly Press, 1999.

Chun, Clayton K. S. *Gothic Serpent: Black Hawk Down Mogadishu 1993*. Oxford: Osprey, 2012.

Durant, Michael J. *In the Company of Heroes*. New York: G. P. Putnam's Sons, 2003.

l. 1993–1995, Bosnia: Operation Deny Flight

Military Doctrine

Secretary of the Air Force. *Survival and Code of Conduct Training*. Air Force Instruction 36-2209. Washington, DC: Secretary of the Air Force, February 28, 1994.

Combat Search and Rescue (CSAR)

Haun, Phil M., and Christopher E. Haave. *A-10s over Kosovo: The Victory of Airpower over a Fielded Army as Told by Airmen Who Fought in Operation Allied Force*. Montgomery, AL: Air University Press, 2003.

O'Grady, Scott, and Michael French. *Basher Five-Two: The True Story of F-16 Fighter Pilot Captain Scott O'Grady*. New York: Bantam Doubleday Dell, 1997.

Richardson, Nick. *No Escape Zone*. London: Little, Brown and Co., 2000.

m. 1998–1999, Kosovo: Operation Allied Force

Military Doctrine

Chairman, Joint Chiefs of Staff. *Doctrine for Joint Combat Search and Rescue*. JP 3-50.2. Washington, DC: CJCS, 1996.

Chairman, Joint Chiefs of Staff. *Joint Doctrine for Evasion and Recovery*. JP 3-50.3. Washington, DC: CJCS, 1996.

Department of the Air Force. *Aircrew Survival*. AFP 64-5. Washington, DC: U.S. Government Printing Office, 1996.

Under Secretary of Defense for Policy. *Personnel Recovery Response Cell (PRRC) Procedures*. DoD Instruction 2310.3. Washington, DC: Under Secretary of Defense for Policy, June 6, 1997.

Department of the Air Force. *Air Force Basic Doctrine*. AFDD1. Washington, DC: Department of the Air Force, 1997.

Department of the Air Force. *Combat Search and Rescue*. AFDD 2-1.6. Washington, DC: Department of the Air Force, 1998.

Chairman, Joint Chiefs of Staff. *Joint Tactics, Techniques, and Procedures for Combat Search and Rescue*. JP 3-50.21. Washington, DC: CJCS, 1998.

Department of the Army. *Survival, Evasion, and Recovery*. Multi-Service Tactics, Techniques and Procedures, FM 21-76-1/MCRP 3-02H/NWP 3-50.3/AFTTP (I) 3-2.26. Washington, DC: Department of the Army, 1999.

Combat Search and Rescue

Simpson, Ross W. *Stealth Down: The Loss of the First F-117 Stealth Fighter in Combat and the Dramatic Rescue of the Pilot*. Charleston, SC: Narwhal Press, 2003.

n. 2000, Sierra Leone: Operation Barras

Fowler, Will. *Certain Death in Sierra Leone: The SAS and Operation Barras 2000*. Oxford: Osprey, 2000.

Lewis, Damien. *Operation Certain Death: The Inside Story of the SAS's Greatest Battle*. London: Arrow Books, 2005.

o. 2001–2015, Afghanistan: Operation Enduring Freedom

Military Doctrine

Australian Department of Defence. *Joint Personnel Recovery*. ADDP 3.6. Canberra: Department of Defence, 2011.

Bush, George W. *United States Citizens Taken Hostage Abroad*. NSPD-12. Washington, DC: The White House, 2002.

Bush, George W. *U.S. Policy on Personnel Recovery and the Prevention of Hostage-Taking and Other Isolating Events*. NSPD-12 Annex 1. Washington, DC: The White House, 2002.

Chairman of the Joint Chiefs of Staff. *Department of Defense Survival, Evasion, Resistance, and Escape Psychology Program*. CJCS Manual 3500.11. Washington, DC: Chairman of the Joint Chiefs of Staff, November 29, 2013.

Chairman, Joint Chiefs of Staff. *Personnel Recovery*. CJCS Instruction 3270.01B. Washington, DC: CJCS, January 23, 2015.

Chairman, Joint Chiefs of Staff. *Personnel Recovery*. JP 3-50. Washington, DC: CJCS, 2007.

Chairman, Joint Chiefs of Staff. *Personnel Recovery*. JP 3-50. Washington, DC: CJCS, 2011.

Chairman, Joint Chiefs of Staff. *Personnel Recovery*. JP 3-50. Washington, DC: CJCS, 2015.

Chairman of the Joint Chiefs of Staff (CJCS). *Personnel Recovery within the Department of Defense*. CJCS Instruction 3270.01A. Washington, DC: Chairman of the Joint Chiefs of Staff, July 1, 2003.

Chairman of the Joint Chiefs of Staff (CJCS). *Personnel Recovery within the Department of Defense*. CJCS Instruction 3270.01A (Secret). Washington, DC: Chairman of the Joint Chiefs of Staff, January 23, 2015.

Department of the Air Force. *Personnel Recovery Operations*. 2-1.6. Washington, DC: Department of the Air Force, 2005.

Department of the Air Force. *Personnel Recovery Operations*. AFDD 3-50. Washington, DC: Department of the Air Force, 2011.

Department of the Air Force. *Personnel Recovery Operations*. AFDD 3-50. Washington, DC: Department of the Air Force, 2013.

Department of the Air Force. *Personnel Recovery*. Annex 3-50. Washington, DC: Department of the Air Force, 2016.

Department of the Army. *Army Personnel Recovery*. FM 3-50. Washington, DC: Department of the Army, 2014.

Department of the Army. *Army Personnel Recovery*. FM 3-50.1. Washington, DC: Department of the Army, 2005.

Department of the Army. *Army Personnel Recovery*. FM 3-50.1. Washington, DC: Department of the Army, 2011.

Department of the Army. *Fundamentals of Army Personnel Recovery*. GTA 80-01-001. Washington, DC: Department of the Army, 2014.

Department of the Army. *Special Forces Personnel Recovery*. FM 3-05.231. Washington, DC: Department of the Army, 2003.

- Department of the Army. *Survival*. FM 3-05.70. Washington, DC: Department of the Army, 2002.
- Department of the Army. *Survival, Evasion, and Recovery*. Multi-Service Tactics, Techniques and Procedures, FM 3-50.3/NTTP 3-50.3/AFTTP (I) 3-2.26. Washington, DC: Secretary of the Army, 2007.
- Department of the Army. *Survival, Evasion, and Recovery*. Multi-Service Tactics, Techniques and Procedures, ATP 3-50.3/MCRP 3-02H/NTTP 3-50.3/AFTTP 3-2.26. Washington, DC: Department of the Army, 2012.
- Deputy Secretary of Defense. *Defense Prisoner of War/Missing Personnel Office (DPMO)*. DOD Directive 5110.10. Washington, DC: Deputy Secretary of Defense, 2005.
- Deputy Secretary of Defense. *Personnel Recovery*. DOD Directive 2310.2. Washington, DC: Deputy Secretary of Defense, 2000.
- Deputy Secretary of Defense. *Personnel Recovery in the Department of Defense*. DOD Directive 3002.01E. Washington, DC: Deputy Secretary of Defense, 2009.
- Deputy Secretary of Defense. *Personnel Recovery in the Department of Defense*. DOD Directive 3002.01. Washington, DC: Deputy Secretary of Defense, 2013.
- Deputy Secretary of Defense. *Training and Education to Support the Code of Conduct (CoC)*. DOD Directive 1300.7. Washington, DC: Deputy Secretary of Defense, 2000.
- Deputy Secretary of Defense. *Training and Education to Support the Code of Conduct (CoC)*. DOD Directive 1300.7. Washington, DC: Deputy Secretary of Defense, 2003.
- Forsvaret [Norwegian Armed Forces]. *Direktiv for etterretning [Directive for Intelligence]*. Oslo: Forsvarssjefen [Chief of defense], 2013.
- Forsvaret [Norwegian Armed Forces]. *Direktiv for luftmilitær virksomhet [Directive for air operations]*. Oslo: Forsvarssjefen [Chief of defense], 2014.
- Forsvarsmakten [Swedish Armed Forces]. *Handbok Joint Personnel Recovery [Handbook for Joint Personnel Recovery]*. Stockholm: Forsvarsmakten [Swedish Armed Forces], 2014.
- Forsvarssjef [Chief of defense]. *Direktiv for delegering av myndighet [Directive for delegation of executive agent responsibilities]*. Oslo: CHOD, December 10, 2009.
- Forsvarsstaben [Defence Staff]. *Forsvarets fellesoperative doctrine (FFOD) [Norwegian Armed Forces Joint Doctrine]*. Oslo: Forsvarets stabsskole (FSTS) [Norwegian

- Command and Staff College], Forsvarets høgskole (FHS) [Norwegian Defence University College], 2014.
- Luftforsvaret [Royal Norwegian Air Force]. *Flygertrening, Bestemmelser for Combat Survival Trening for Luftpersonell [Pilot Training, Regulations for Combat Survival Training of Aircrew]*. BFL 65-17. Oslo: Luftoperativt Inspektorat [Inspectorate of Air Operations], 2003.
- Luftforsvaret [Royal Norwegian Air Force]. *Personnel Recovery and SERE certification regulation*. BFL 100-50 Study Draft. Oslo: Generalinspektøren for Luftforsvaret, 2014.
- Matlary, Janne Haaland, Tormod Heier, and Ola Bøe-Hansen. *Strategisk Suksess?: Norsk Maktbruk i Libya og Afghanistan [Strategic success?: Norwegian use of force in Libya and Afghanistan]*. Oslo: Universitetsforlaget, 2013.
- Ministry of Defense. *Joint Personnel Recovery*. JWP 3-66. London: Ministry of Defense, 2003.
- North Atlantic Treaty Organization. *Allied Joint Doctrine for Recovery of Personnel in a Hostile Environment*. AJP-3.7, Edition A, Version 1. Brussels: NATO Standardization Office, 2016.
- North Atlantic Treaty Organization. *Allied Joint Doctrine for Recovery of Personnel in a Hostile Environment*. STANAG 6511 Edition 1. Brussels: NATO Standardization Office, 2016.
- North Atlantic Treaty Organization. *BI-SC Joint Personnel Recovery Joint Operational Guidelines*. BI-SC JPR JOG. Norfolk, VA: Supreme Allied Commander, Transformation, 2011.
- North Atlantic Treaty Organization. *The NATO Survival, Evasion, Resistance and Extraction (SERE) Training Standard*. STANAG 7196 SD 06. Brussels: NATO Standardization Office, 2016.
- North Atlantic Treaty Organization. *Personnel Recovery in NATO Operations*. ACO Directive 080-101. Mons, Belgium: Supreme Headquarters Allied Powers Europe, 2015.
- North Atlantic Treaty Organization. *Personnel Recovery in NATO Operations*. ACO Manual 080-071. Mons, Belgium: Supreme Headquarters Allied Powers Europe, 2016.
- Obama, Barack. *U.S. Nationals Taken Hostage Abroad and Personnel Recovery Efforts*. PPD-30. Washington, DC: The White House, 2015.

- Sjøforsvaret [Royal Norwegian Navy]. *Konsept for Personnel Recovery I Sjøforsvaret [Concept for Personnel Recovery in the Royal Norwegian Navy]*. Bergen: Sjøf Kysteskadren [Commander of the Fleet], 2015.
- Under Secretary of Defense for Policy. *Accounting for Missing Persons—Boards of Inquiry*. DoD Instruction 2310.05. Washington, DC: Under Secretary of Defense for Policy, January 31, 2000.
- Under Secretary of Defense for Policy. *Accounting for Missing Persons—Boards of Inquiry*. DoD Instruction 2310.05. Washington, DC: Under Secretary of Defense for Policy, March 14, 2008.
- Under Secretary of Defense for Policy. *Code of Conduct (CoC) Training and Education*. DoD Instruction 1300.21. Washington, DC: Under Secretary of Defense for Policy, January 8, 2001.
- Under Secretary of Defense for Policy. *DoD Personnel Recovery—Non-Conventional Assisted Recovery (NAR)*. DoD Instruction 3002.04. Washington, DC: Under Secretary of Defense for Policy, November 17, 2014.
- Under Secretary of Defense for Policy. *Non-Conventional Assisted Recovery in the Department of Defense*. DoD Instruction 2310.6. Washington, DC: Under Secretary of Defense for Policy, October 13, 2000.
- Under Secretary of Defense for Policy. *DoD Personnel Recovery—Reintegration of Recovered Personnel*. DoD Instruction 3002.03. Washington, DC: Under Secretary of Defense for Policy, July 15, 2013.
- Under Secretary of Defense (Intelligence). *Intelligence Support to Personnel Recovery*. DoD Instruction 3115.10E. Washington, DC: Under Secretary of Defense (Intelligence), March 24, 2006.

Escape and Evasion (E&E)

- Luttrell, Marcus, and Patrick Robinson. *Lone Survivor: The Eyewitness Account of Operation Redwing and the Lost Heroes of SEAL Team 10*. New York: Little, Brown and Co, 2007.

Hostage Rescue by Special Operations Forces (SOF)

- Buchanan, Jessica, Erik Landemalm, and Anthony Flacco. *Impossible Odds: The Kidnapping of Jessica Buchanan and Her Dramatic Rescue by SEAL Team Six*. New York: Atria Paperback, 2014.

Joseph, Dilip, and James Lund. *Kidnapped by the Taliban: A Story of Terror, Hope, and Rescue by Seal Team Six*. Nashville: W Publishing Group, 2014.

Phillips, Richard, and Stephan Talty. *A Captain's Duty: Somali Pirates, Navy SEALs, and Dangerous Days at Sea*. New York: Hyperion, 2010.

PR Events

Briscoe, Charles H., Richard L. Kiper, James A. Schroder, and Kalev I. Sepp. *Weapon of Choice: U.S. Army Special Operations Forces in Afghanistan*. Fort Leavenworth, KS: Combat Studies Institute Press, 2003.

Carney, John T., and Benjamin F. Schemmer. *No Room for Error: The Covert Operations of America's Special Tactics Units from Iran to Afghanistan*. New York: Presidio Press, 2002.

Hirsh, Michael. *None Braver: U.S. Air Force Pararescuemen in the War on Terrorism*. New York: New American Library, 2003.

MacPherson, Malcolm. *Roberts Ridge: A Story of Courage and Sacrifice on Takur Ghar Mountain, Afghanistan*. New York: Delacorte Press, 2005.

Macy, Ed. *Apache*. London: Harper Press, 2008.

Naylor, Sean. *Not a Good Day to Die: The Untold Story of Operation Anaconda*. New York: Berkley Books, 2005.

Neville, Leigh. *Takur Ghar: The SEALs and Rangers on Roberts Ridge, Afghanistan 2002*. Oxford: Osprey, 2013.

p. 2003–2015, Iraq: Operation Iraqi Freedom

Urban, Mark. *Task Force Black: The Explosive True Story of the SAS and the Secret War in Iraq*. London: Little, Brown, 2010.

McChrystal, Stanley, Tatum Collins, David Silverman, and Chris Fussell. *Team of Teams: New Rules of Engagement for a Complex World*. New York: Portfolio Penguin, 2015.

q. 2011–2015, Libya

Zuckoff, Mitchell. *13 Hours: The Inside Account of What Really Happened in Benghazi*. New York: Twelve, 2014.

D. CURRENT MILITARY POLICY AND DOCTRINE

a. United States (U.S.)

Law

Obama, Barack. *U.S. Nationals Taken Hostage Abroad and Personnel Recovery Efforts*. PPD-30. Washington, DC: The White House, 2015.

Department of Defense Directives (DoDD)

Deputy Secretary of Defense. *Defense Prisoner of War/Missing Personnel Office (DPMO)*. DOD Directive 5110.10. Washington, DC: Deputy Secretary of Defense, 2005.

Deputy Secretary of Defense. *Personnel Recovery in the Department of Defense*. DOD Directive 3002.01E. Washington, DC: Deputy Secretary of Defense, 2009.

Deputy Secretary of Defense. *Training and Education to Support the Code of Conduct (CoC)*. DOD Directive 1300.7. Washington, DC: Deputy Secretary of Defense, 2000.

Department of Defense Instructions (DoDI)

Under Secretary of Defense for Policy. *Accounting for Missing Persons—Boards of Inquiry*. DoD Instruction 2310.05. Washington, DC: Under Secretary of Defense for Policy, January 31, 2000.

Under Secretary of Defense for Policy. *Code of Conduct (CoC) Training and Education*. DoD Instruction 1300.21. Washington, DC: Under Secretary of Defense for Policy, January 8, 2001.

Under Secretary of Defense for Policy. *DoD Personnel Recovery—Nonconventional Assisted Recovery (NAR)*. DoD Instruction 3002.04. Washington, DC: Under Secretary of Defense for Policy, November 17, 2014.

Under Secretary of Defense for Policy. *DoD Personnel Recovery—Reintegration of Recovered Personnel*. DoD Instruction 3002.03. Washington, DC: Under Secretary of Defense for Policy, July 15, 2013.

Under Secretary of Defense for Policy. *DoD Support to Civil Search and Rescue (SAR)*. DoD Instruction 3003.01. Washington, DC: Under Secretary of Defense for Policy, September 26, 2011.

Under Secretary of Defense for Policy. *Isolated Personnel Training for DoD Civilian and Contractors*. DoD Instruction 1300.23. Washington, DC: Under Secretary of Defense for Policy, August 20, 2003.

Under Secretary of Defense (Intelligence). *Intelligence Support to Personnel Recovery*. DoD Instruction 3115.10E. Washington, DC: Under Secretary of Defense (Intelligence), March 24, 2006.

Chairman of the Joint Chiefs of Staff (CJCS) Publications

Chairman of the Joint Chiefs of Staff (CJCS). *Personnel Recovery*. CJCS Instruction 3270.01B. Washington, DC: Chairman of the Joint Chiefs of Staff, January 23, 2015.

Chairman, Joint Chiefs of Staff (CJCS). *Personnel Recovery within the Department of Defense (U)*. CJCS Instruction 3270.01A (Secret/NOFORN). Washington, DC: CJCS, January 23, 2015.

Joint Publications (JP)

Chairman, Joint Chiefs of Staff. *Department of Defense Dictionary of Military and Associated Terms (as amended through 15 July 2011)*. JP 1-02. Washington, DC: CJCS, 2010.

Chairman, Joint Chiefs of Staff. *Joint and National Intelligence Support to Military Operations*. JP 2-01. Washington, DC: CJCS, December 20, 2011.

Chairman, Joint Chiefs of Staff. *Personnel Recovery*. JP 3-50. Washington, DC: CJCS, 2011.

Multi-Service Publications

Department of the Army. *Survival, Evasion, and Recovery*. Multi-Service Tactics, Techniques and Procedures, ATP 3-50.3/MCRP 3-02H/NTTP 3-50.3/AFTTP 3-2.26. Washington, DC: Department of the Army, 2012.

United States Army Publications

Department of the Army. *Army Personnel Recovery*. FM 3-50. Washington, DC: Department of the Army, 2014.

Department of the Army. *Army Personnel Recovery*. Handbook 09-25. Washington, DC: Department of the Army, 2009.

Department of the Army. *Evasion and Escape*. FM 21-77. Washington, DC: Department of the Army, 1958.

Department of the Army. *Fundamentals of Army Personnel Recovery*. GTA 80-01-001. Washington, DC: Department of the Army, 2014.

Department of the Army. *Personnel Recovery*. AR 525-28. Washington, DC: Department of the Army, 2010.

Department of the Army. *Special Forces Personnel Recovery*. FM 3-05.231. Washington, DC: Department of the Army, 2003.

Department of the Army. *Survival*. FM 3-05.70. Washington, DC: Department of the Army, 2002.

Department of the Army. *Survival*. FM 21-76. Washington, DC: Department of the Army, 1986.

Department of the Army. *The Warrior Ethos and Soldier Combat Skills*. FM 3-21.75. Washington, DC: Department of the Army, 2008.

United States Air Force Publications

Department of the Air Force. *Personnel Recovery*. Annex 3-50. Washington, DC: Department of the Air Force, 2016.

Department of the Air Force. *Personnel Recovery Coordination Cell Operating Procedures*. AFI 13-208. Washington, DC: Department of the Air Force, 2012.

b. North Atlantic Treaty Organization (NATO)

North Atlantic Treaty Organization. *Allied Joint Doctrine for Recovery of Personnel in a Hostile Environment*. AJP-3.7, Edition A, Version 1. Brussels: NATO Standardization Office, 2016.

North Atlantic Treaty Organization. *Allied Joint Doctrine for Recovery of Personnel in a Hostile Environment*. STANAG 6511 Edition 1. Brussels: NATO Standardization Office, 2016.

North Atlantic Treaty Organization. *The NATO Survival, Evasion, Resistance and Extraction (SERE) Training Standard*. STANAG 7196 SD 06. Brussels: NATO Standardization Office, 2016.

North Atlantic Treaty Organization. *Personnel Recovery in NATO Operations*. ACO Directive 080-101. Mons, Belgium: Supreme Headquarters Allied Powers Europe, 2015.

North Atlantic Treaty Organization. *Personnel Recovery in NATO Operations*. ACO Manual 080-071. Mons, Belgium: Supreme Headquarters Allied Powers Europe, 2016.

United Kingdom

Ministry of Defence. *Joint Personnel Recovery*. JWP 3-66. London: Ministry of Defence, 2003.

Norway

Forsvaret [Norwegian Armed Forces]. *Direktiv for luftmilitær virksomhet* [Directive for air operations]. Oslo: Forsvarssjefen [Chief of defense], 2014.

Luftforsvaret [Royal Norwegian Air Force]. *Flygertrening, Bestemmelser for Combat Survival trening for luftpersonell* [Pilot Training, Regulations for Combat Survival Training of Aircrew]. BFL 65-17. Oslo: Luftoperativt Inspektorat [Inspectorate of Air Operations], 2003.

Luftforsvaret [Royal Norwegian Air Force]. *Personnel Recovery and SERE Certification Regulation*. BFL 100-50 Study Draft. Oslo: Generalinspektøren for Luftforsvaret [Inspector General of the Royal Norwegian Air Force], 2014.

Sjøforsvaret [Royal Norwegian Navy]. *Konsept for Personnel Recovery I Sjøforsvaret* [Concept for Personnel Recovery in the Royal Norwegian Navy]. Bergen: Sjef Kysteskadren [Commander of the Fleet], 2015.

Australia

Department of Defence. *Joint Personnel Recovery*. ADDP 3.6. Canberra: Department of Defence, 2011.

Sweden

Forsvarsmakten [Swedish Armed Forces]. *Handbok Joint Personnel Recovery* [Joint personnel recovery handbook]. Stockholm: Forsvarsmakten [Swedish Armed Forces], 2014.

E. ACADEMIC THESES

Cline, John D. "Under New Management: Will America's Dedicated CSAR Forces Finally Thrive in AFSOC?" Master's thesis, Naval Postgraduate School, 2004.

Dorl, Thomas R. "Personnel Recovery and the DOTMLPF Changes Needed for the Twenty-First Century." Master's thesis, Joint Advanced Warfighting School, 2005.

Dunphy, Christopher C. "Combat Search and Rescue: An American Way of War." Master's thesis, United States Marine Corps Command and Staff College, 2001.

Ecklund, Marshal V., and Michael A. McNerney. "Personnel Recovery Operations for Special Operations Forces in Urban Environments: Modeling Successful Overt and Clandestine Methods of Recovery." Master's thesis, Naval Postgraduate School, 2004.

Gingrich, Jason N. "Combat Search and Rescue: A Joint Endeavour." Master's thesis, United States Marine Corps Command and Staff College, 2010.

Groves, John M. "A Combat Search and Rescue (CSAR) Role for the CV-22: It's Coming, Get Ready." Master's thesis, United States Marine Corps Command and Staff College, 2008.

Meggett, David C. "Evolution of Rescue: Personnel Recovery for a New Environment." Master's thesis, Naval Postgraduate School, 2007.

Moakley, Geoffrey S. "U.S. Army Code of Conduct Training: Let the POWs Tell Their Stories." Master's thesis, United States Army Command and General Staff College, 1976.

Patterson, Eric A. "Unconventional Assisted Recovery (UAR): Historical Case Study Analysis and Quantitative Feasibility Assessment." Master's thesis, Naval Postgraduate School, 2001.

Rowell, William J. "Whole of Government Approach to Personnel Recovery." Master's thesis, United States Army War College, 2012.

Wormly, Michael A. "Combat Search and Rescue: Searching the History; Rescuing the Doctrine." Master's thesis, Air University, 2003.

F. UNPUBLISHED RESEARCH PAPERS

Banik, Neal. "Integrating Unmanned Aerial Vehicles (UAVs) With Current Combat Search and Rescue (CSAR) Doctrine." Unpublished Research Paper, Air Command and Staff College, 2003.

G. JOURNAL ARTICLES

Moentmann, James E., Edward E. Holland, and Gary A. Wolver. "Joint Combat Search and Rescue: Operational Necessity or Afterthought?" *Joint Forces Quarterly* (Spring 1998): 44–51.

Pera, Lee, Paul D. Miller, and Darrel Whitcomb. "Personnel Recovery: Strategic Importance and Impact." *Air & Space Power Journal* (November-December 2012): 83–112.

Sterr, Chad. "Strategic Rescue: Vectoring Airpower Advocates to Embrace the Real Value of Personnel Recovery." *Air & Space Power Journal* (January 2011): 26–35.

Todorov, Kenneth E., and Glenn H. Hecht. "Air Force Personnel Recovery as a Service Core Function: It's Not 'Your Father's Combat Search and Rescue.'" *Air & Space Power Journal* (Fall 2011): 7–11.

THIS PAGE INTENTIONALLY LEFT BLANK

APPENDIX B. DESIGN AND DESIGN THINKING BIBLIOGRAPHY

- Ackoff, Russell L. *Ackoff's Best: His Classic Writings on Management*. New York: John Wiley & Sons, 1999.
- Audi, Robert. *Epistemology: A Contemporary Introduction to the Theory of Knowledge*. 3rd edition. London: Routledge, 2011.
- Brown, Tim. *Change by Design: How Design Thinking Transforms Organizations and Inspires Innovation*. New York: Harper Collins, 2009.
- Buzan, Tony. *The Ultimate Book of Mind Maps*. London: Thorsons, 2005.
- Buzan, Tony, and Chris Griffiths. *Mind Maps for Business: Using the Ultimate Thinking Tool to Revolutionise How You Work*. Boston: Pearson Education, 2014.
- Christensen, Clayton M. *The Innovator's Dilemma: The Revolutionary Book That Will Change the Way You Do Business*. New York: Harvard Business School Press, 1997.
- Christensen, Clayton M., and Michael E. Raynor. *The Innovator's Solution: Creating and Sustaining Successful Growth*. Boston: Harvard Business Review Press, 2003.
- Churchman, C. West. *The Systems Approach*. New York: Dell Publishing, 1968.
- Churchman, C. West. *The Systems Approach and Its Enemies*. New York: Basic Books, 1979.
- Cohen, Don, and Laurence Prusak. *In Good Company: How Social Capital Makes Organizations Work*. Boston: Harvard Business School Press, 2001.
- Cross, Nigel. *Design Thinking*. London: Bloomsbury, 2011.
- Dewey, John. *Art as Experience*. London: Penguin Books, 1934.
- Dewey, John. *How We Think*. Boston, MA: Heath, 1933.
- Dewey, John. *Logic: The Theory of Inquiry*. New York: H. Holt and Co, 1938.
- Dewey, John. *The Quest for Certainty: a Study of the Relation of Knowledge and Action*. New York: Minton Balch, 1929.
- Doorley, Scott, and Scott Witthoft. *Make Space: How to Set the Stage for Creative Collaboration*. Hoboken, NJ: John Wiley & Sons, 2012.

- Dyer, Jeff, Hal Gregersen, and Clayton M. Christensen. *The Innovator's DNA: Mastering The Five Skills of Disruptive Innovators*. Boston: Harvard Business Review Press, 2011.
- Egolf, Donald B.. *Forming Storming Norming Performing: Successful Communication in Groups and Teams*. New York: iUniverse, 2007.
- Gedenryd, Henrik. *How Designers Work: Making Sense of Authentic Cognitive Activity*. Lund: Jabe Offset AB, 1988.
- Heath, Chip, and Dan Heath. *Made to Stick: Why Some Ideas Survive and Others Die*. New York: Random House, 2007.
- Heath, Chip, and Dan Heath. *Switch: How to Change Things When Change Is Hard*. New York: Broadway Books, 2010.
- Henry, Todd. *The Accidental Creative: How To Be Brilliant at a Moment's Notice*. New York: Penguin Group, 2013.
- Kelley, Tom, and David Kelley. *Creative Confidence: Unleashing the Creative Potential within Us All*. New York: Crown Business, 2013.
- Kelley, Tom, and Jonathan Littman. *The Art of Innovation: Lessons in Creativity from IDEO, America's Leading Design Firm*. New York: Doubleday, 2001.
- Kelley, Tom, and Jonathan Littman. *The Ten Faces of Innovation*. New York: Doubleday, 2005.
- Kolko, Jon. *Exposing the Magic of Design: A Practitioner's Guide to the Methods & Theory of Synthesis*. New York: Oxford University Press, 2011.
- Krippendorff, Klaus. *The Semantic Turn: A New Foundation for Design*. Boca Raton, FL: CRC Press, 2006.
- Linstone, Harold A. *Multiple Perspectives for Decision Making: Bridging the Gap between Analysis and Action*. New York: Elsevier Science, 1984.
- Margolin, Victor, and Richard Buchanan. *The Idea of Design*. Cambridge, MA: The MIT Press, 1995.
- Martin, Roger. *The Design of Business*. Boston: Harvard Business Press, 2009.
- Meadows, Donella H. *Thinking in Systems: A Primer*. White River Junction, VT: Chelsea Green, 2008.
- Nelson, Harold G., and Erik Stolterman. *The Design Way: Intentional Change in an Unpredictable World*. London: MIT Press, 2014.

- Neumeier, Marty. *The Designful Company: How to Build a Culture of Nonstop Innovation*. Berkley: New Riders, 2009.
- Patnaik, Dev, and Peter Mortensen. *Wired to Care: How Companies Prosper When They Create Widespread Empathy*. Upper Saddle River, NJ: Pearson Education, 2009.
- Protzen, Jean-Pierre, and David J. Harris. *The Universe of Design: Horst Rittel's Theories of Design and Planning*. London: Routledge, 2010.
- Schon, Donald A. *Educating the Reflective Practitioner*. San Francisco: Jossey-Bass, 1987.
- Schon, Donald A. *The Reflective Practitioner*. Cambridge, MA: MIT Press, 1983.
- Snow, C. P. *The Two Cultures*. New York: Cambridge University Press, 1998.
- Sutton, Robert I. *Weird Ideas That Work: How to Build a Creative Company*. New York: Free Press, 2002.
- Sutton, Robert I., and Huggy Rao. *Scaling Up Excellence: Getting to More Without Settling for Less*. New York: Crown Business, 2014.
- Thornberry, Neal. *Innovation Judo: Disarming Roadblocks and Blockheads on the Path to Creativity*. Ashland, OH: Evolve, 2014.
- Tufte, Edward R. *Beautiful Evidence*. Cheshire, CT: Graphics Press, 2006.
- Tufte, Edward R. *The Visual Display of Quantitative Information*. Cheshire, CT: Graphics Press, 2001.
- Tufte, Edward R. *Visual Explanation: Images and Quantities, Evidence and Narratives*. Cheshire, CT: Graphics Press, 1997.
- Van 't Hof, Sjon, and Bob Williams. *Wicked Solutions: A Systems Approach to Complex Problems*. 2016. <http://www.bobwilliams.co.nz/wicked.pdf>.
- Van Wulfen, Gijs. *The Innovation Expedition: A Visual Toolkit to Start Innovation*. Amsterdam: BIS, 2013.
- Wilson, Chauncey. *Brainstorming and Beyond: A User-Centered Design Method*. Oxford: Elsevier, 2013.

ORGANIZATIONAL THEORY BIBLIOGRAPHY

- Chisholm, Donald. *Coordination without Hierarchy: Informal Structures in Multiorganizational Systems*. Berkeley: University of California Press, 1989.
- Galbraith, Jay R. *Organization Design*. London: Addison, 1977.

THIS PAGE INTENTIONALLY LEFT BLANK

APPENDIX C. NETWORK DESIGN THEORY BIBLIOGRAPHY

- Anklam, Patti. *Net Work: A Practical Guide to Creating and Sustaining Networks at Work and in the World*. New York: Butterworth-Heinemann, 2007.
- Arquilla, John, and David Ronfeldt. *Networks and Netwars*. Santa Monica, CA: RAND, 2001.
- Barabasi, Albert-Laszlo. *Linked: How Everything Is Connected to Everything Else and What It Means for Business, Science, and Everyday Life*. New York: Plume, 2003.
- Christakis, Nicholas A., and James H. Fowler. *Connected: The Surprising Power of Our Social Networks and How They Shape Our Lives*. New York: Little, Brown and Company, 2009.
- d.school. "An Introduction to Design Thinking Process Guide." August 2, 2012.
https://dschool.stanford.edu/groups/designresources/wiki/36873/Design_Process_MiniGuide.html.
- Flick, Deborah L. *From Debate to Dialogue: Using the Understanding Process to Transform Our Conversation*. Boulder, CO: Orchid, 1998.
- Holohan, Anne. *Networks of Democracy: Lessons from Kosovo for Afghanistan, Iraq, and Beyond*. Stanford, CA: Stanford University Press, 2005.
- IDEO. "The Field Guide to Human-Centered Design." 2015.
<https://www.ideo.com/work/human-centered-design-toolkit/#rO8T9ViVxE8QRYAV.99>.
- Kenis, Patrick, and Keith G. Provan. "Modes of Network Governance: Structure, Management, and Effectiveness." *Journal of Public Administration Research and Theory* 18, no. 2 (2008): 229–252. doi:10.1093/jopart/mum015.
- Kenis, Patrick, and Keith G. Provan. "Towards an Exogenous Theory of Public Network Performance." *Public Administration* 87, no. 3 (July 2009): 440–56. doi: 10.1111/j.1467-9299.2009.01775.x.
- Milward, H. Brinton, and Keith G. Provan. *A Manager's Guide to Choosing and Using Collaborative Networks*. Washington, DC: IBM Center for the Business of Government, 2006.
<http://www.businessofgovernment.org/sites/default/files/CollaborativeNetworks.pdf>.
- Watts, Duncan J. *Six Degrees: The Science of a Connected Age*. New York: W. W. Norton & Company, 2003.

THIS PAGE INTENTIONALLY LEFT BLANK

APPENDIX D. COMMUNITIES OF PRACTICE

Alle, Verna. *The Future of Knowledge: Increasing Prosperity through Value Networks*. Burlington, MA: Butterworth-Heinemann, 2003.

Cohen, Don, and Laurence Prusak. *In Good Company: How Social Capital Makes Organizations Work*. Boston: Harvard Business School Press, 2001.

Senge, Peter M. *The Fifth Discipline: The Art & Practice of the Learning Organization*. New York: Doubleday, 2006.

Wenger-Trayner, Etienne, Mark Fenton-O’Creevy, Steven Hutchinson, Chris Kubiak, and Beverly Wenger-Trayner. *Learning in Landscapes of Practice*. New York: Routledge, 2015.

Wenger-Trayner, Etienne, Richard McDermott, and William M. Snyder. *Cultivating Communities of Practice: A Guide to Managing Knowledge*. Boston: Harvard Business School Press, 2002.

THIS PAGE INTENTIONALLY LEFT BLANK

APPENDIX E. NPRN CORE STRUCTURE

The prototype draws the Norwegian Armed Forces PR Network structure, based on the main actors involved in PR: isolated personnel, forces, and commanders and staffs. This prototype first draws each of these actors as a separate subnetwork of the NPRN to illustrate the parts of the whole network, then merges them together as a whole.

This first category of PR commanders and staffs “includes commanders and staffs trained to integrate and synchronize PR planning and operations into all operational activities.”²⁹² The Joint Force Commander (JFC) “prepares for, plans and executes PR within the Joint Operations Area (JOA). The JFC establishes a PR architecture within the JOA, command relationships and procedures for PR operations, and the identification of intelligence requirements for PR, and assures that PR is an integral part of planning and training.”²⁹³

The JFC exercises his PR responsibility through his PR command and control architecture as seen in Figure 47.

²⁹² NATO, *Allied Joint Doctrine for Recovery of Personnel*, 2-1.

²⁹³ *Ibid.*, 4-1.

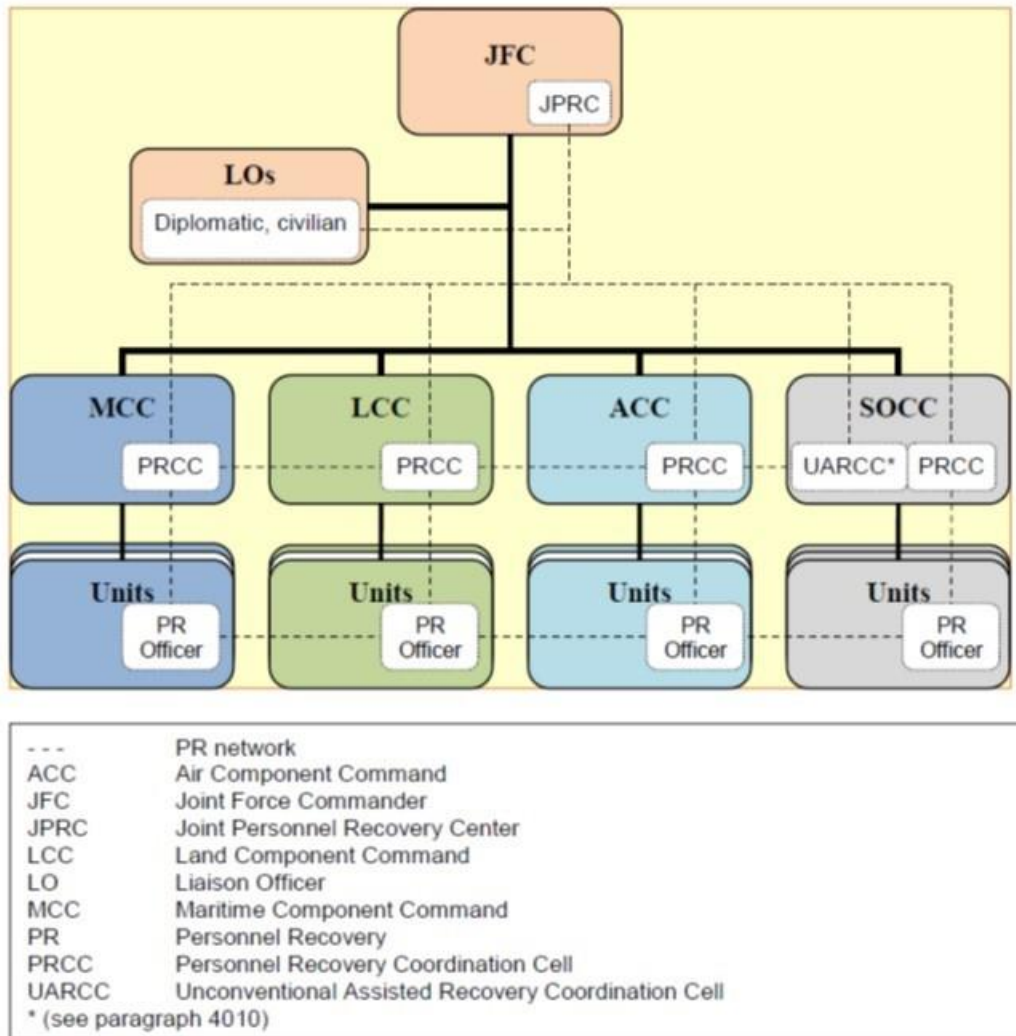

Figure 47. Notional Personnel Recovery Organization Structure²⁹⁴

The PR network, as illustrated in Figure 47, provides a hierarchical chain of PR commanders and staffs to facilitate the reporting of PR events. The PR architecture provides a network of PR-competent planners and operations officers who have the necessary education and training to support the five PR tasks of report, locate, support, recover, and reintegrate.

I have drawn the NPRN prototype based on the 2016 NATO *Allied Joint Doctrine for Recovery of Personnel in a Hostile Environment*'s²⁹⁵ notional personnel recovery

²⁹⁴ Ibid., 4-4.

organization structure, as seen in Figure 47 To depict the network forces, I have used the *Strategic Defence Review 2015's* Overview of Norwegian Armed Forces Operational Structure as recommended by the CHOD, illustrated in Figure 48.²⁹⁶



Figure 48. Overview of Norwegian Armed Forces Operational Structure²⁹⁷

²⁹⁵ NATO, *Allied Joint Doctrine for Recovery of Personnel*.

²⁹⁶ Norwegian Armed Forces, *Norwegian Armed Forces in Transition: Strategic Defence Review by the Norwegian Chief of Defence* (Oslo: CHOD, 2015), 15: https://forsvaret.no/en/ForsvaretDocuments/Strategic_Defence_Review_2015_abridged.pdf.

²⁹⁷ Ibid.

The NPRN spans the whole of the Norwegian Armed Forces operational structure; for the prototype, however, I have used the RNoAF as an example. The RNoAF subnetworks are illustrated one by one and merged in the end to show the RNoAF aggregate network structure as an example for all services. First, I present a prototype of the PR command and control (C2) architecture for commanders and staffs. Second, I develop the forces' network structure. Third, I present the isolated personnel network structure. Finally, I merge all RNoAF subnetwork structures into one to visualize what an NPRN service structure could look like.

a. PR Commanders and Staffs

I begin illustrating the commanders and staffs subnetwork by drawing the RNoAF PR C2 architecture. Figure 49 provides a visualization of the PR C2 network structure as it starts at the top with the JFC and his Joint Personnel Recovery Centre at the Norwegian Joint Headquarters.

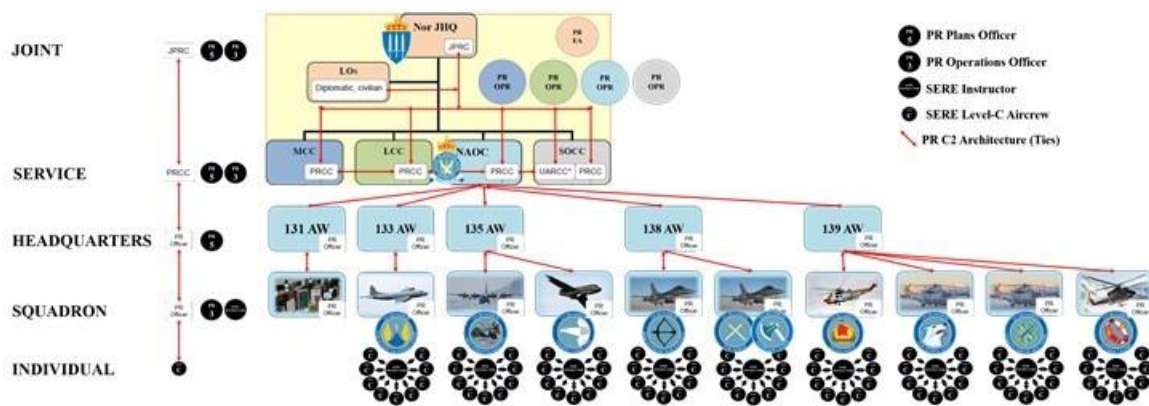

This illustration uses the RNoAF as an example to show the PR commanders and staffs tracing the network from the JFC to the individual SERE level-C trained aircrew at each example squadron as per the NATO notional PR architecture.

Figure 49. RNoAF PR C2 Architecture²⁹⁸

²⁹⁸ Prototype model built by the author, adapted from the Notional PR Organizational Structure found in NATO, *Allied Joint Doctrine for Recovery of Personnel*, 4-4.

From the JFC and his JPRC, the PR C2 structure branches out to the various services' tactical commands. As illustrated on the left side of the figure, the network starts at the joint level with the JFC and the JPRC, connects to the service level and the Personnel Recovery Coordination Cell (PRCC), spreads out to five airwings and their headquarters. Then the network continues down to the various squadrons and finally terminates at the individual PR and SERE trained aircrew. PR planners and operations officers, labeled 5 and 3 according to their staff functions, are the network nodes at the joint and service levels. At the squadron level, the node is labeled PR Officer, which can be represented by a person that is either a PR planner, operations officer, SERE instructor, or a SERE trained aircrew. In Figure 50, the same network is shown in a cleaner configuration where only the human nodes in the network are visualized from the JPRC to the individual aircrew at the squadron level.

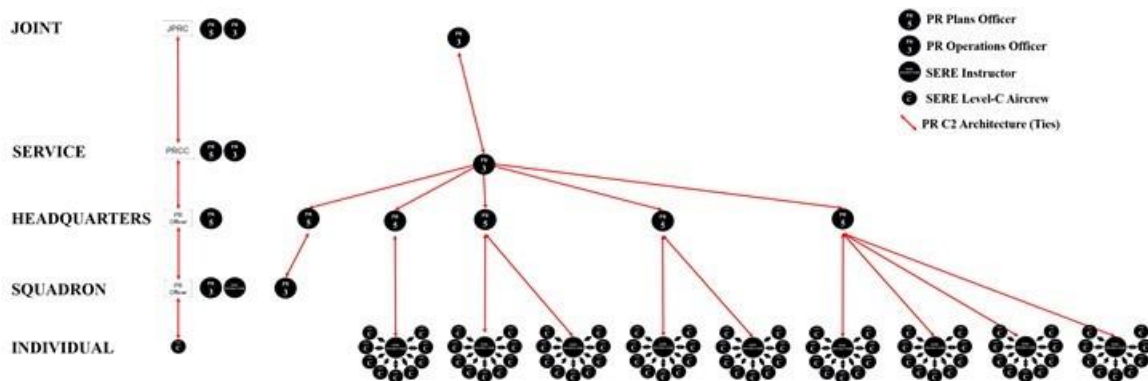

Figure 50. RNoAF PR C2 Architecture Clean²⁹⁹

The membership in the commanders and staffs PR subnetwork as illustrated in Figures 49 and 50 is criteria-based. The network actors hold specific functions as a PR planner or an operations officer in a JPRC, a service PRCC, or in an air wing HQ staff, as a PR officer at the squadron level as well. The RNoAF PR C2 network structure highlights the need for PR-competent planners and operations officers especially at the JPRC and PRCC organizational nodes. PR planners are especially important actors at the

²⁹⁹ Prototype model built by the author.

joint and service levels, as they are responsible for producing important PR plans and annexes to any operations orders, either for peacetime exercises or, most importantly, for real operations. PR operations officers are critical in order to act on any PR event based on PR plans and their own current operation's situational awareness.

Figure 51 illustrates and adds the network, in blue, that is created by the education and training of PR planners and operations officers by the RNoAF office of primary responsibility for PR (OPR PR).

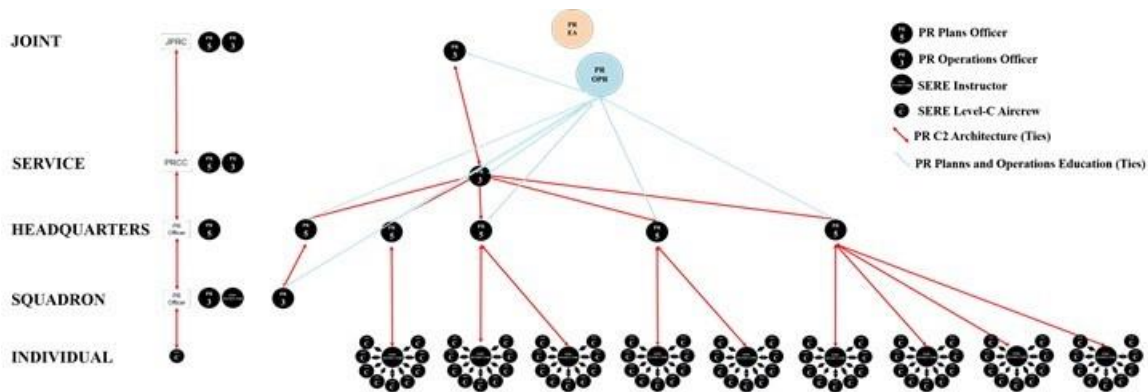

Figure 51. RNoAF PR C2 Architecture with Education and Training³⁰⁰

The education of PR planners and operations officers is most important for their capability to execute their PR preparation, planning, and execution functions in the PR system. The education and training organization and network OPR should support these functions by providing initial training of PR planners and operations officers thereafter to serve as a reachback source of PR knowledge and competence for the PR officers.

b. PR Forces

The second subnetwork prototype is drawn based on the RNoAF PR-dedicated and capable forces. Figure 52 illustrates the network of forces as shown by the chain of command from the JFC, through the National Air Operations Centre (NAOC), to the RNoAF flying squadrons.

³⁰⁰ Prototype model built by the author.

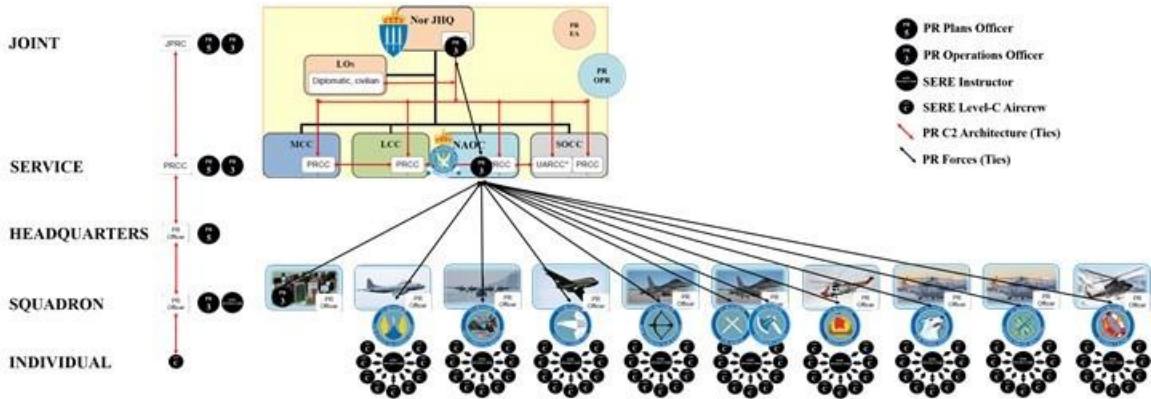

Only the 330 Squadron with its national search and rescue mission is a PR-dedicated force; the other squadrons are considered PR-capable based on how they can contribute and support PR execution tasks like report, locate, support, and recover.

Figure 52. RNoAF PR Forces³⁰¹

Figure 53 adds the education and training network, in blue, to the operational command and control network.

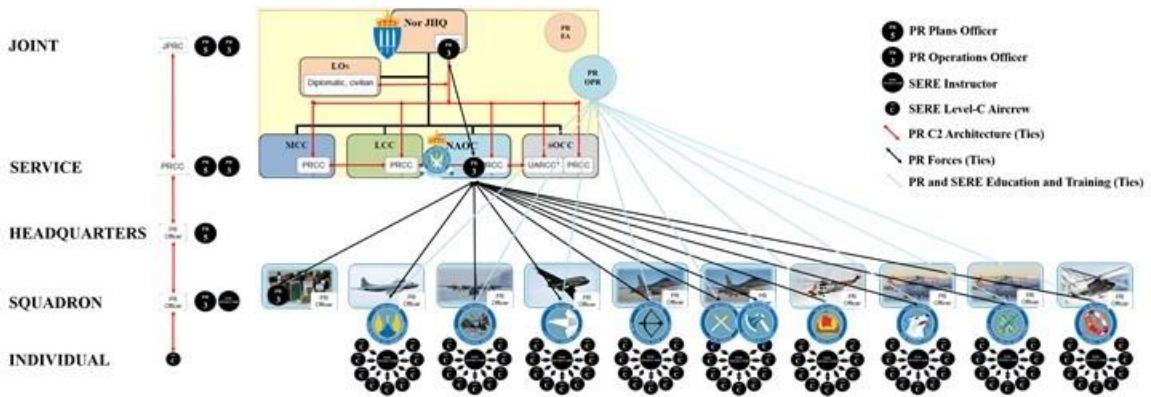

Figure 53. RNoAF PR Forces with Education and Training³⁰²

³⁰¹ Prototype model built by the author adapted from the Notional PR Organizational Structure found in NATO, *Allied Joint Doctrine for Recovery of Personnel*, 4-4.

³⁰² Prototype model built by the author adapted from the Notional PR Organizational Structure found in NATO, *Allied Joint Doctrine for Recovery of Personnel*, 4-4.

In sum, Figure 53 depicts both the operational network from the NAOC and the added network created by the RNoAF OPR PR and the education and training they provide to the forces in their roles as either a PR-dedicated force or a PR-capable force.

c. Isolated Personnel

The final RNoAF PR subnetwork depicts isolated personnel. The network membership criteria is based on the role as isolated personnel, or as a SERE instructor, or as the OPR training institution. The PR education and training network of isolated personnel originates at the RNoAF OPR PR and flows down to the individual aircrew at the squadron level through the local squadron SERE instructors, as seen in Figure 54.

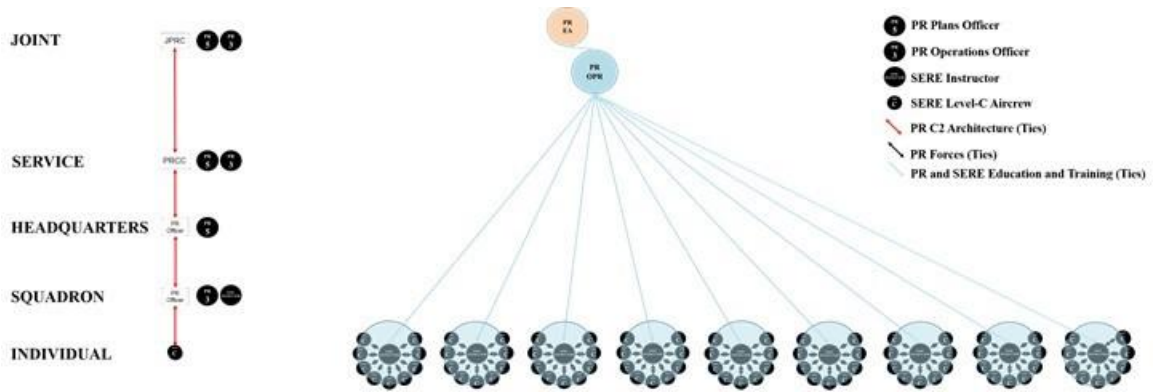

Figure 54. RNoAF Isolated Personnel with Education and Training³⁰³

d. NPRN and the RNoAF PR Network

In sum, the RNoAF PR subnetworks have been created based on three groups of actors. The core nodes that create the foundation of the RNoAF contribution to the NPRN are the RNoAF OPR PR, commanders and staffs, forces, and isolated personnel. The core network prototype is depicted in Figure 55.

³⁰³ Prototype model built by the author adapted from the Notional PR Organizational Structure found in NATO, *Allied Joint Doctrine for Recovery of Personnel*, 4-4.

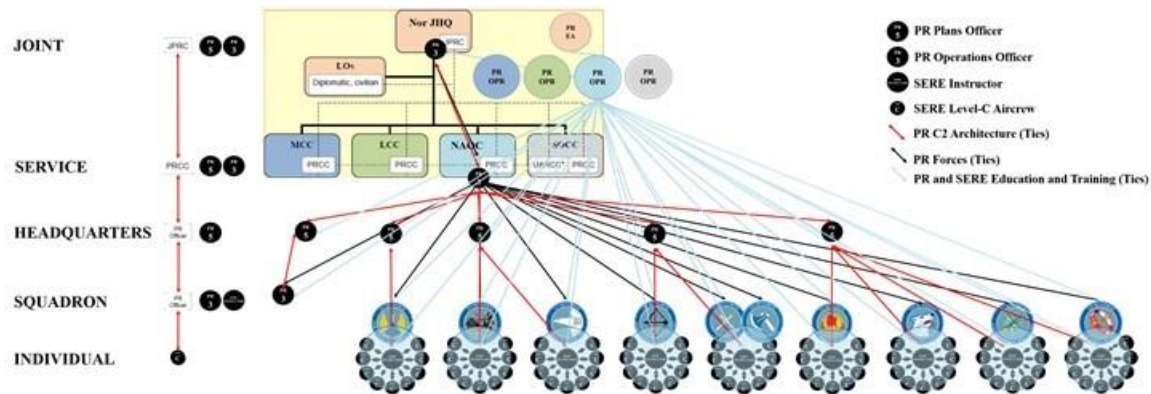

Figure 55. RNoAF Aggregate of the NPRN³⁰⁴

The network, when fully developed, will add additional nodes that originate from each of these core actors as they are identified in the construction of the network and as it continues to develop its connections. The aggregate RNoAF PR network illustrates key nodes that are located at all levels from the JFC all the way down to the individual aircrew. The PR system model also illustrates the importance of addressing all levels of the system and depicts this in the preparation function of the model, as seen in Figure 56.

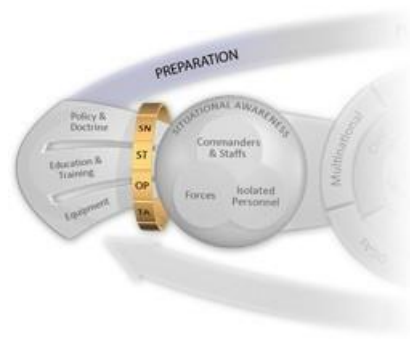

Figure 56. PR System Levels

The PR system model labels the levels: strategic national, strategic theater, operational, and tactical.

³⁰⁴ Prototype model built by the author adapted from the Notional PR Organizational Structure found in NATO, *Allied Joint Doctrine for Recovery of Personnel*, 4-4.

Figures 57–77 provide the same network structure prototypes for the Norwegian Army, Navy, and the Norwegian Special Forces, as previously illustrated by the RNoAF example.

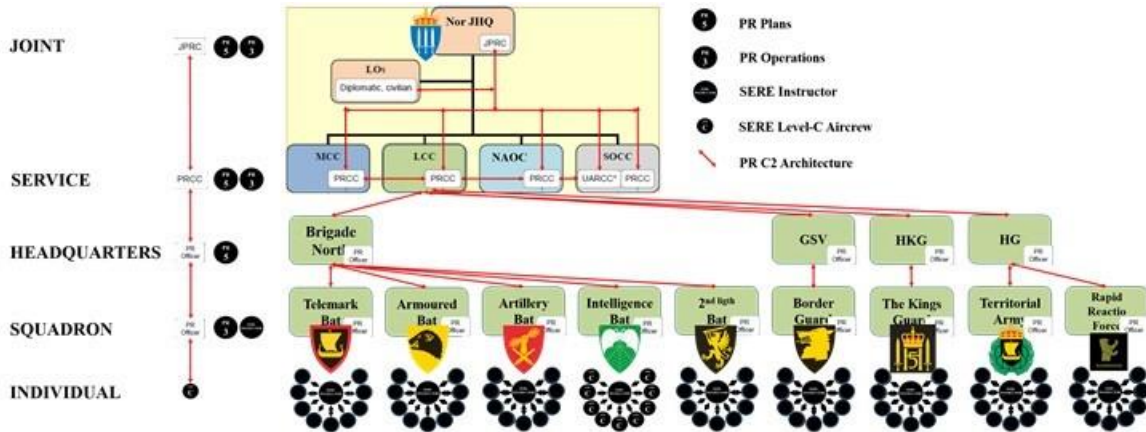

Figure 57. Norwegian Army PR C2 Architecture³⁰⁵

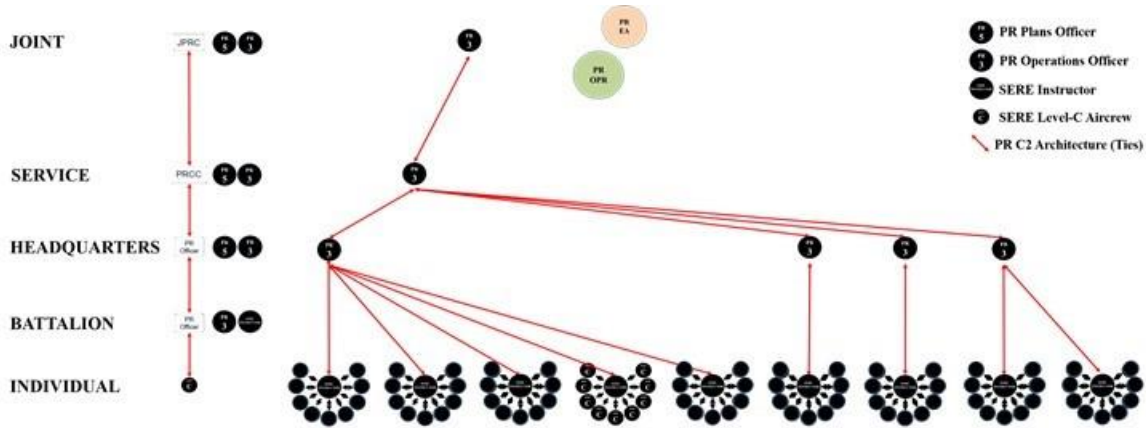

Figure 58. Norwegian Army PR C2 Architecture Clean³⁰⁶

³⁰⁵ Prototype model built by the author adapted from the Notional PR Organizational Structure found in NATO, *Allied Joint Doctrine for Recovery of Personnel*, 4-4.

³⁰⁶ Prototype model built by the author adapted from the Notional PR Organizational Structure found in NATO, *Allied Joint Doctrine for Recovery of Personnel*, 4-4.

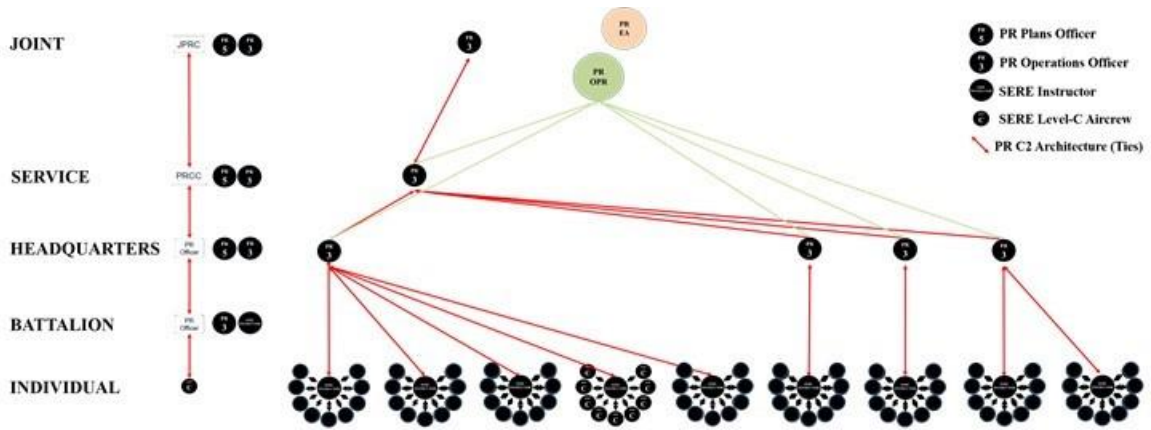

Figure 59. Norwegian Army PR C2 Architecture with Education and Training³⁰⁷

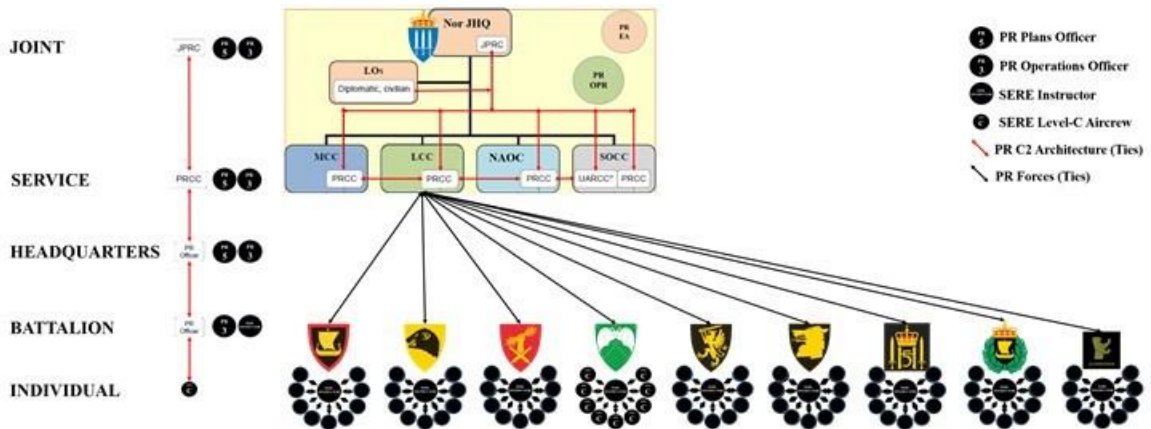

Figure 60. Norwegian Army PR Forces³⁰⁸

³⁰⁷ Prototype model built by the author adapted from the Notional PR Organizational Structure found in NATO, *Allied Joint Doctrine for Recovery of Personnel*, 4-4.

³⁰⁸ Prototype model built by the author adapted from the Notional PR Organizational Structure found in NATO, *Allied Joint Doctrine for Recovery of Personnel*, 4-4.

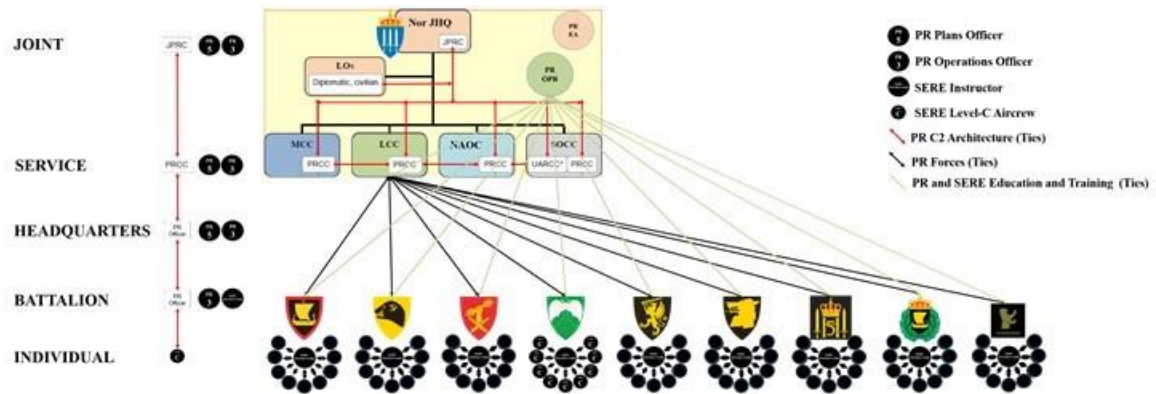

Figure 61. Norwegian Army PR Forces with Education and Training³⁰⁹

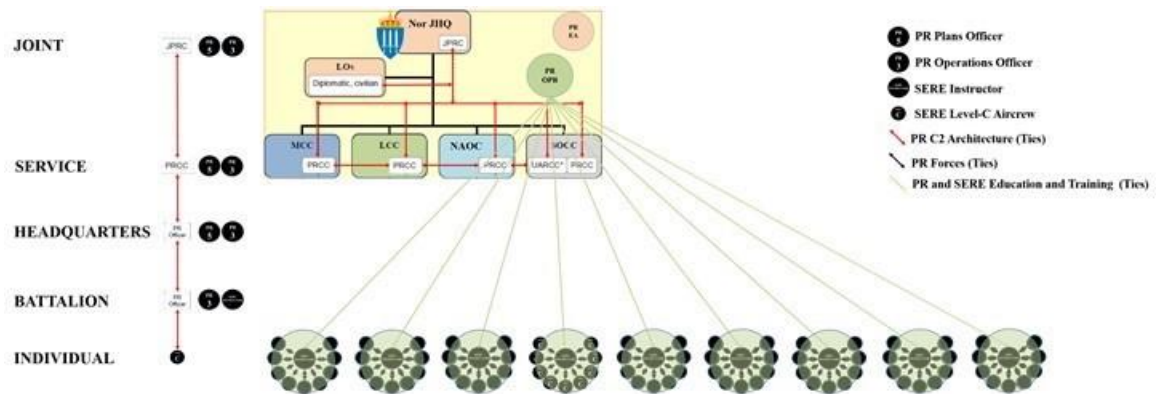

Figure 62. Norwegian Army Isolated Personnel with Education and Training³¹⁰

³⁰⁹ Prototype model built by the author adapted from the Notional PR Organizational Structure found in NATO, *Allied Joint Doctrine for Recovery of Personnel*, 4-4.

³¹⁰ Prototype model built by the author adapted from the Notional PR Organizational Structure found in NATO, *Allied Joint Doctrine for Recovery of Personnel*, 4-4.

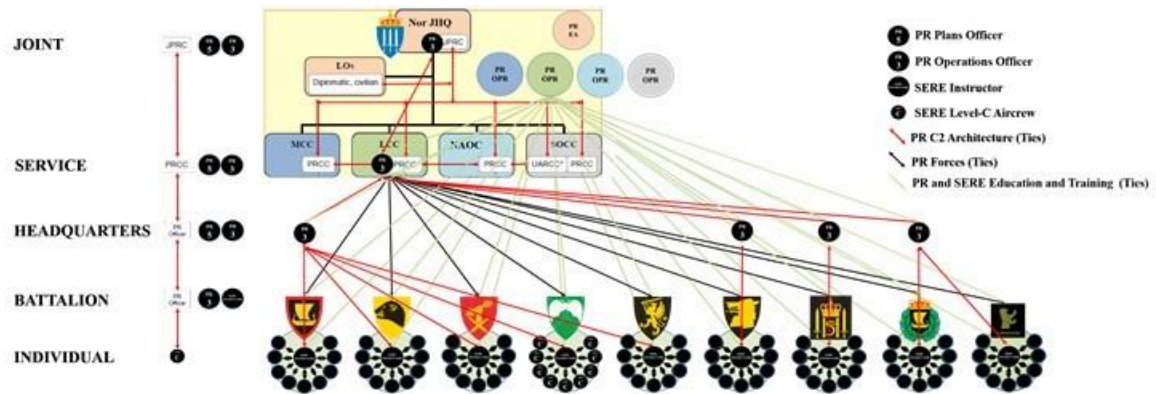

Figure 63. Norwegian Army Aggregate of the NPRN³¹¹

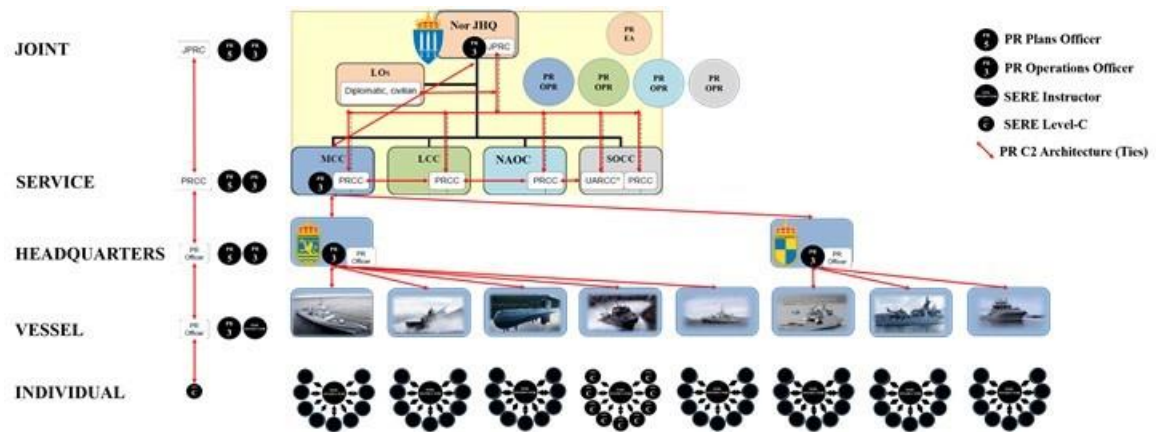

Figure 64. Norwegian Navy PR C2 Architecture³¹²

³¹¹ Prototype model built by the author is adapted from the Notional PR Organizational Structure found in NATO, *Allied Joint Doctrine for Recovery of Personnel*, 4-4.

³¹² Prototype model built by the author is adapted from the Notional PR Organizational Structure found in NATO, *Allied Joint Doctrine for Recovery of Personnel*, 4-4.

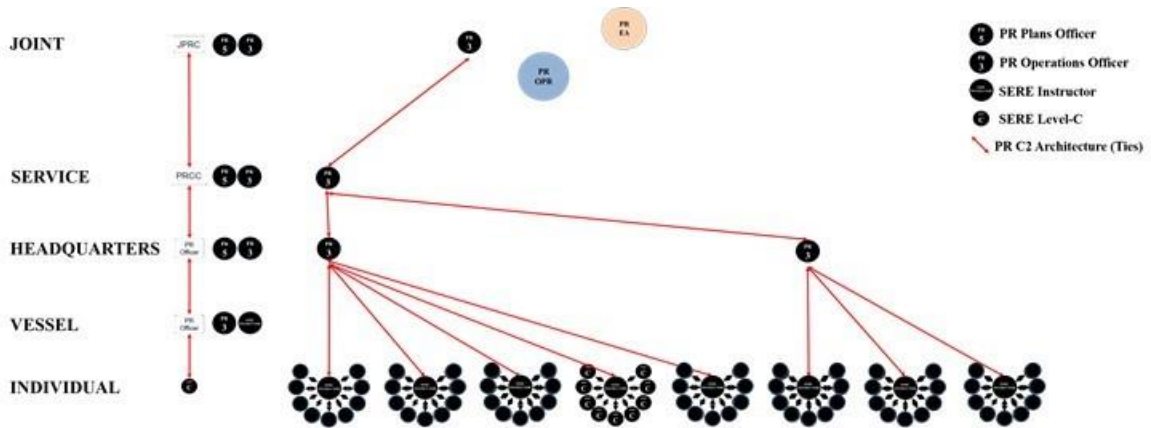

Figure 65. Norwegian Navy PR C2 Architecture Clean³¹³

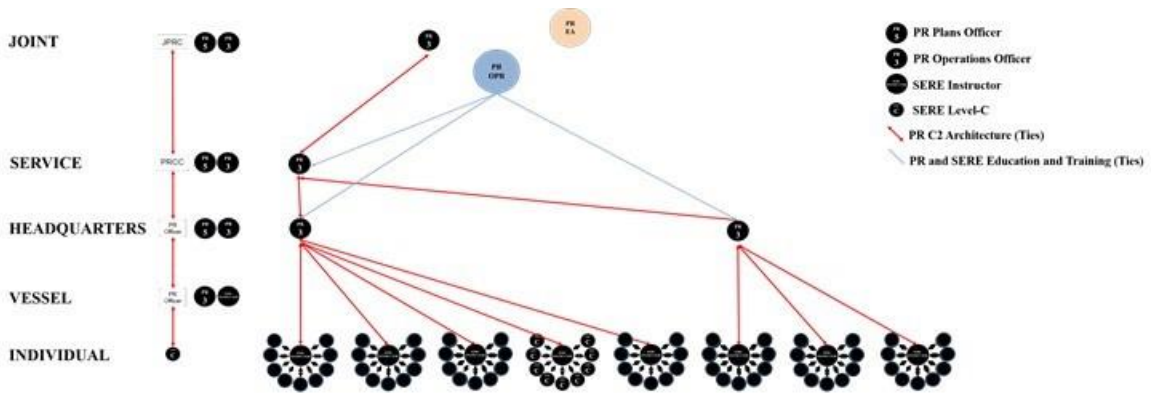

Figure 66. Norwegian Navy PR C2 Architecture with Education and Training³¹⁴

³¹³ Prototype model built by the author is adapted from the Notional PR Organizational Structure found in NATO, *Allied Joint Doctrine for Recovery of Personnel*, 4-4.

³¹⁴ Prototype model built by the author is adapted from the Notional PR Organizational Structure found in NATO, *Allied Joint Doctrine for Recovery of Personnel*, 4-4.

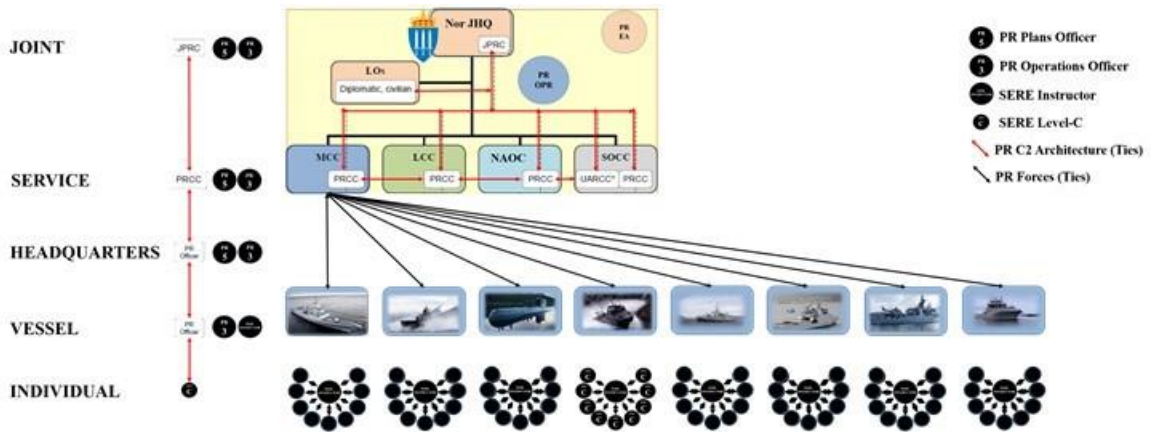

Figure 67. Norwegian Navy PR Forces³¹⁵

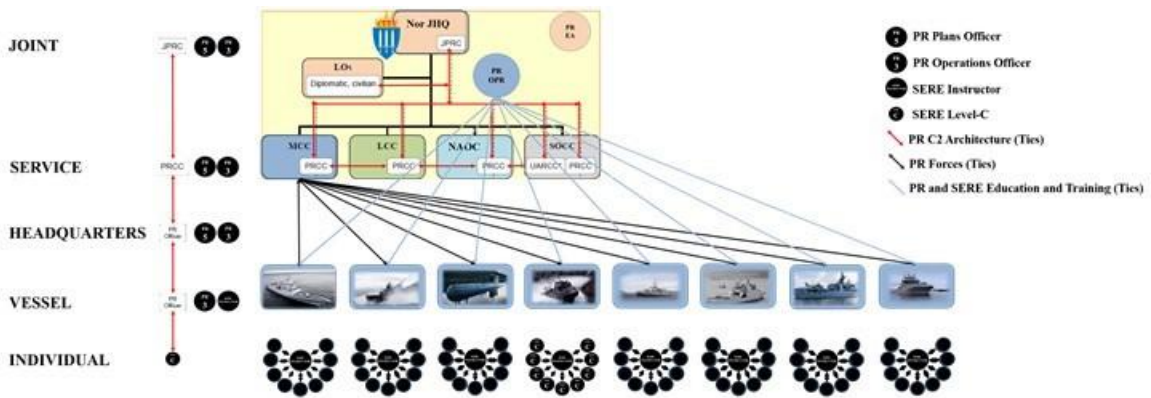

Figure 68. Norwegian Navy PR Forces with Education and Training³¹⁶

³¹⁵ Prototype model built by the author is adapted from the Notional PR Organizational Structure found in NATO, *Allied Joint Doctrine for Recovery of Personnel*, 4-4.

³¹⁶ Prototype model built by the author is adapted from the Notional PR Organizational Structure found in NATO, *Allied Joint Doctrine for Recovery of Personnel*, 4-4.

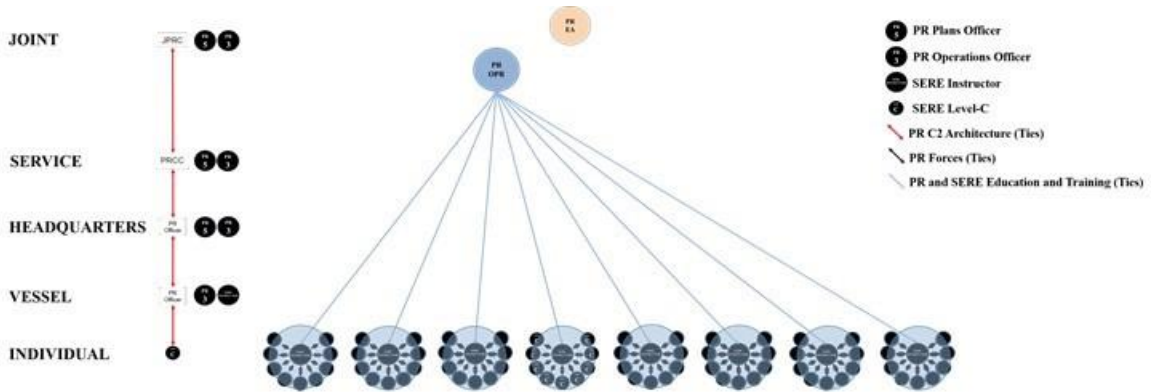

Figure 69. Norwegian Navy Isolated Personnel and Education and Training³¹⁷

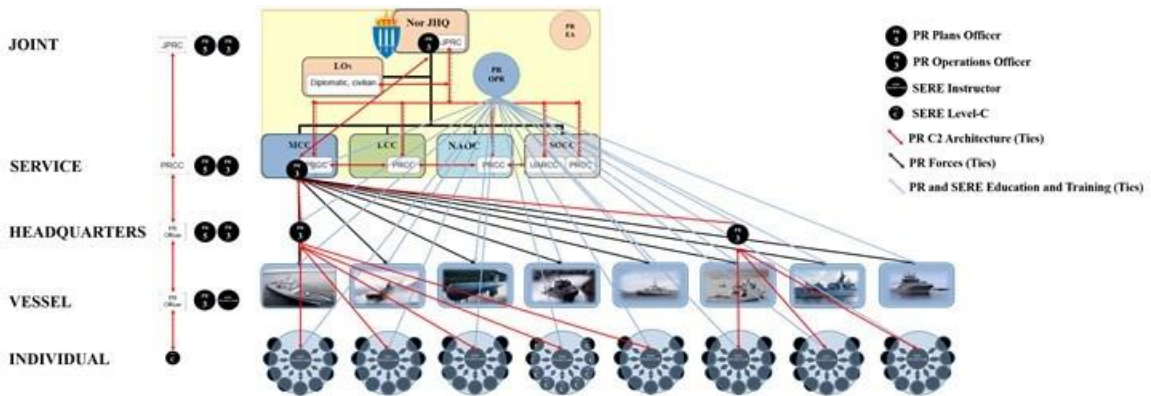
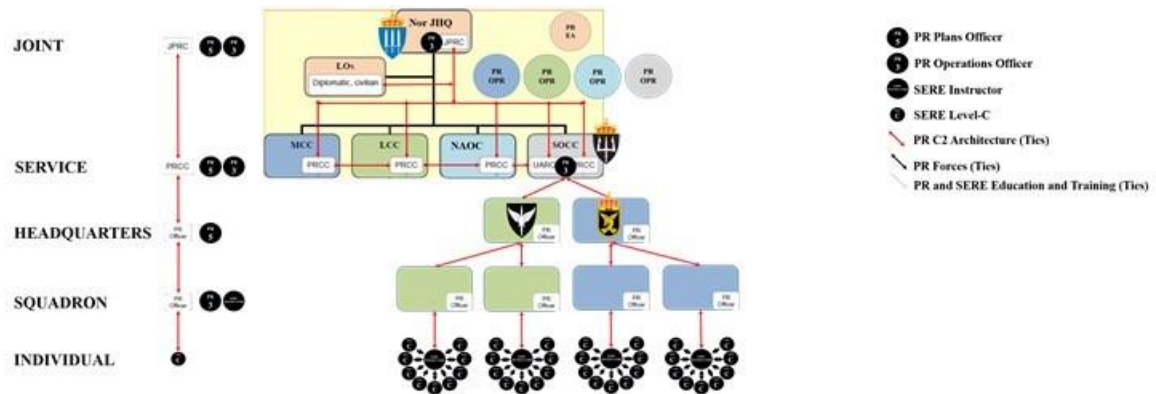

Figure 70. Navy Aggregate of the NPRN³¹⁸

³¹⁷ Prototype model built by the author is adapted from the Notional PR Organizational Structure found in NATO, *Allied Joint Doctrine for Recovery of Personnel*, 4-4.

³¹⁸ Prototype model built by the author is adapted from the Notional PR Organizational Structure found in NATO, *Allied Joint Doctrine for Recovery of Personnel*, 4-4.



Generic NORSOFF PR C2 Architecture. Number of squadrons and individuals for illustration only.

Figure 71. NORSOFF PR C2 Architecture³¹⁹

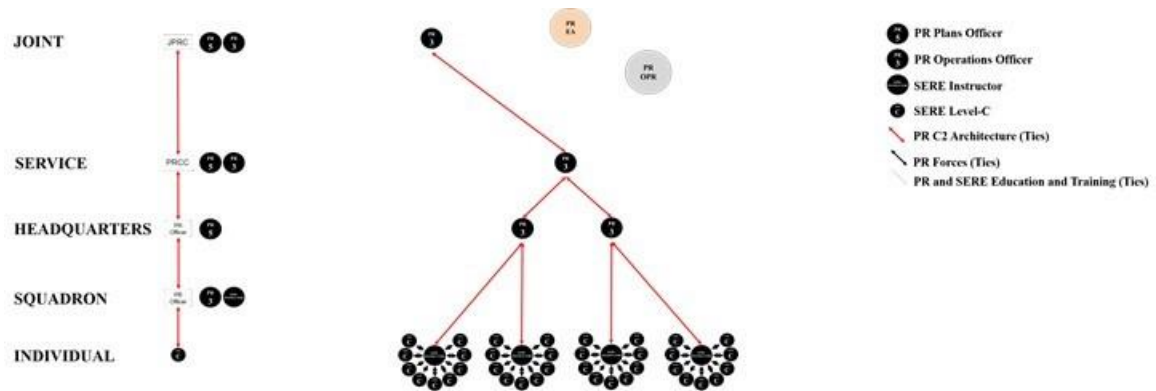

Figure 72. NORSOFF PR C2 Architecture Clean³²⁰

³¹⁹ Prototype model built by the author is adapted from the Notional PR Organizational Structure found in NATO, *Allied Joint Doctrine for Recovery of Personnel*, 4-4.

³²⁰ Prototype model built by the author is adapted from the Notional PR Organizational Structure found in NATO, *Allied Joint Doctrine for Recovery of Personnel*, 4-4.

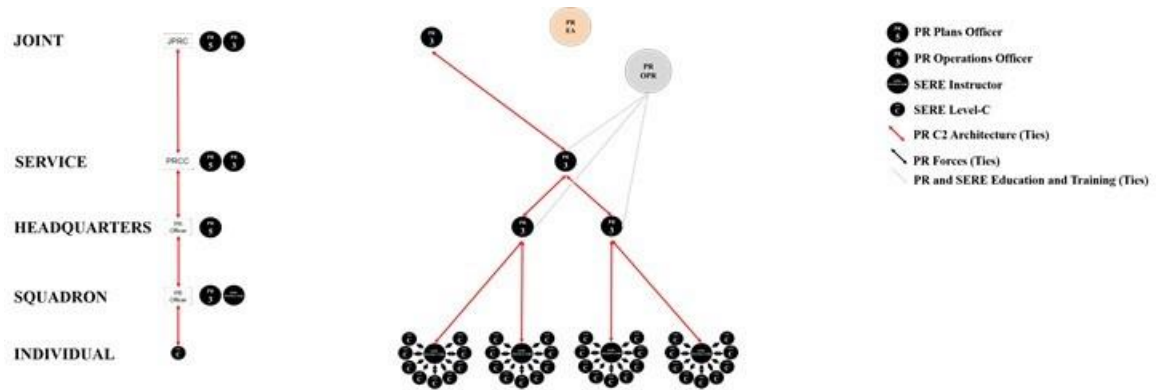

Figure 73. NORSOF PR C2 Architecture with Education and Training³²¹

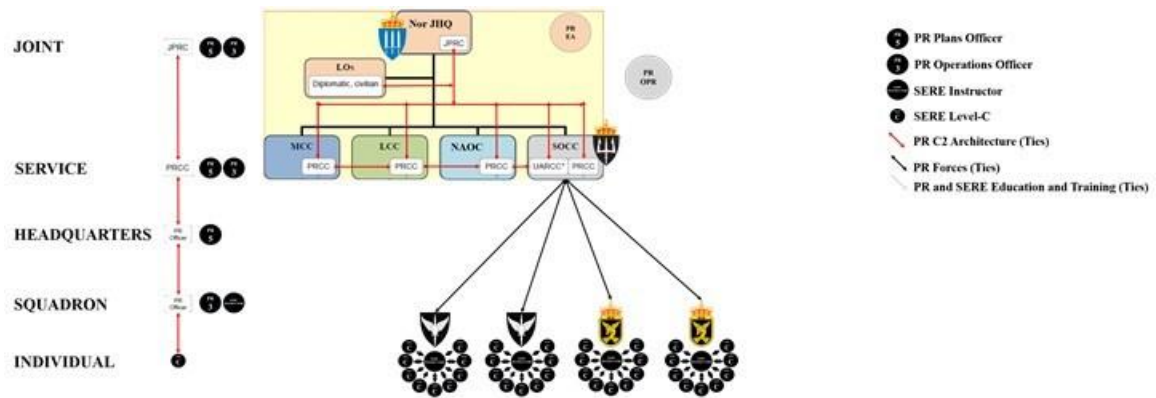

Figure 74. NORSOF PR Forces³²²

³²¹ Prototype model built by the author is adapted from the Notional PR Organizational Structure found in NATO, *Allied Joint Doctrine for Recovery of Personnel*, 4-4.

³²² Prototype model built by the author is adapted from the Notional PR Organizational Structure found in NATO, *Allied Joint Doctrine for Recovery of Personnel*, 4-4.

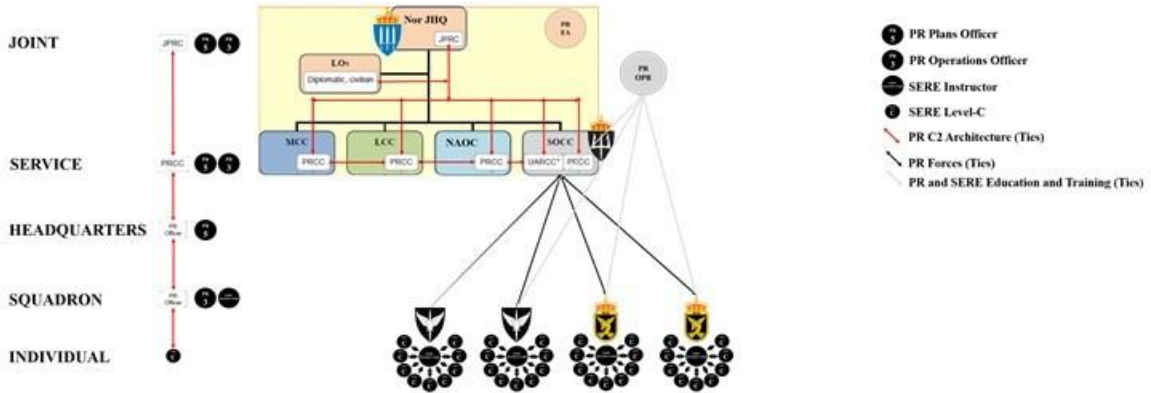

Figure 75. NORSOF PR Forces with Education and Training³²³

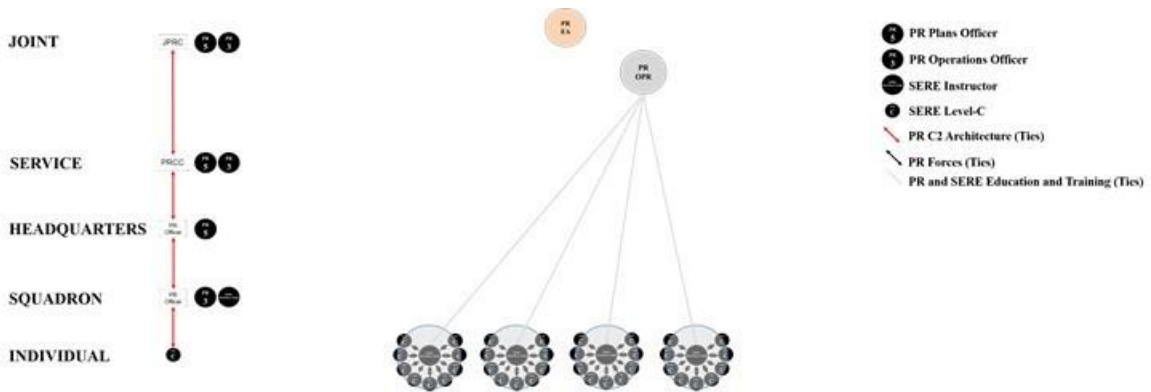

Figure 76. NORSOF Isolated Personnel with Education and Training³²⁴

³²³ Prototype model built by the author is adapted from the Notional PR Organizational Structure found in NATO, *Allied Joint Doctrine for Recovery of Personnel*, 4-4.

³²⁴ Prototype model built by the author is adapted from the Notional PR Organizational Structure found in NATO, *Allied Joint Doctrine for Recovery of Personnel*, 4-4.

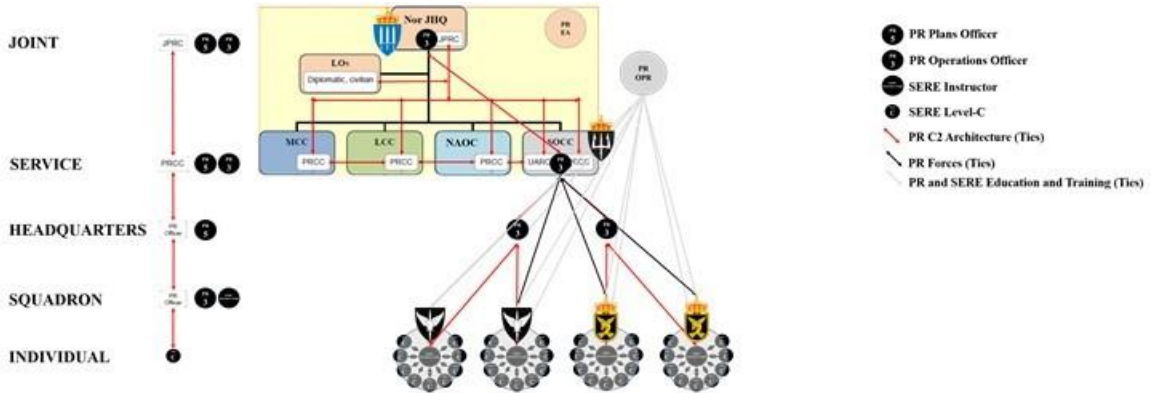

Figure 77. NORSOF Aggregate of the NPRN³²⁵

With all the services' intraorganizational sub networks of the NPRN drawn, Figure 78 merges all subnetworks into the NPRN at the interorganizational level:

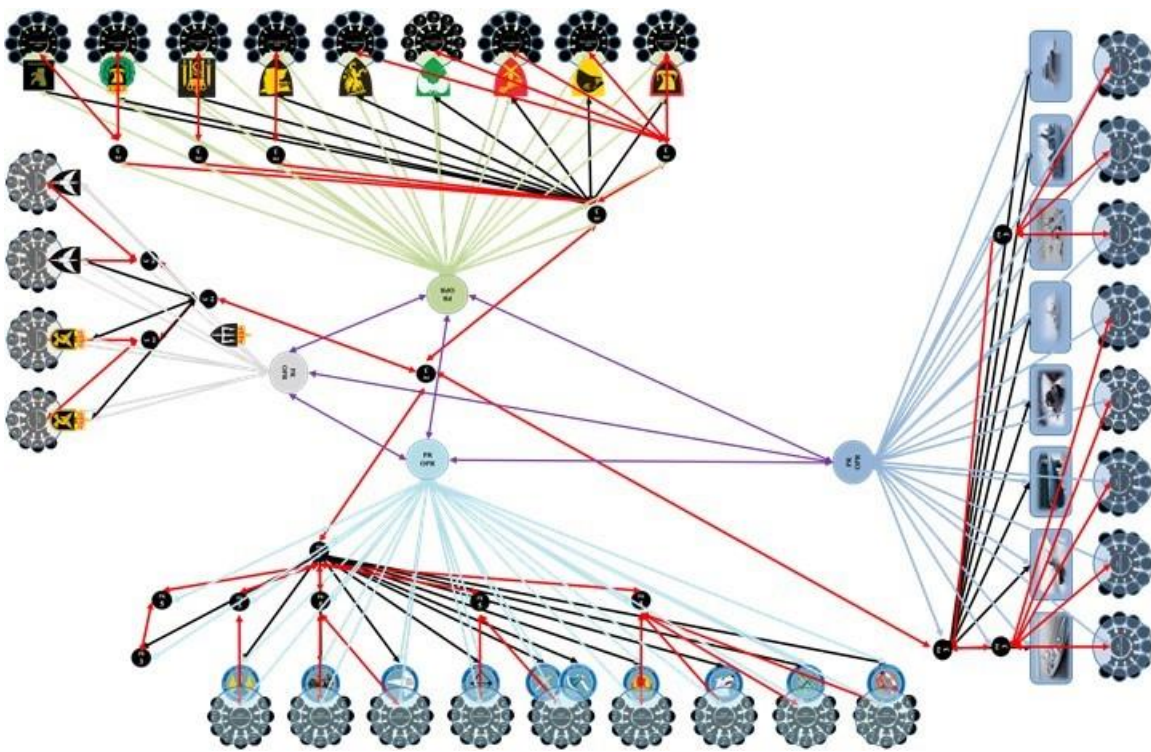

Figure 78. NPRN Aggregate³²⁶

³²⁵ Prototype model built by the author is adapted from the Notional PR Organizational Structure found in NATO, *Allied Joint Doctrine for Recovery of Personnel*, 4-4.

³²⁶ Prototype model built by the author is adapted from the Notional PR Organizational Structure found in NATO, *Allied Joint Doctrine for Recovery of Personnel*, 4-4.

For prototyping purposes, Figure 78 illustrates the NPRN with all its core actors, commanders and staff, forces, isolated personnel, and the services' education and training institutions. From this core NPRN structure, the network can be expanded with additional members as each service and the PR community of practice see fit and as the prototype meets real life in its implementation.

THIS PAGE INTENTIONALLY LEFT BLANK

APPENDIX F. PR DOCTRINAL EVOLUTION

This Appendix on PR Doctrine provides an overview of the evolution of PR doctrine and views the PR system with a doctrinal lens and perspective as it provides guidance for PR to isolated personnel, forces, and commanders and staffs.

To understand policy and doctrine from the perspective of the actors and stakeholders in the PR system, I follow the evolution from WWII and onward and how PR doctrine has evolved from the individual to the strategic level, from the isolated personnel to the president. First, the initial development in WWII from 1940–1945 is covered. Second, the development caused by the Korean War is addressed. Third, the Vietnam War and its influence on doctrine is shown. Fourth, Operation Desert Storm caused further development, and finally the last decade and a half of fighting in Afghanistan and Iraq and the war on terror's impact on PR is summed up.

WWII (1940–1945). The first PR doctrine available for the preparation, education, and training of isolated personnel was provided by the British Military Intelligence 9 (MI9). The objectives of MI9 were, among others, to “facilitate escapes of British prisoners of war,” to “facilitate the return to the United Kingdom to those who succeeded in evading capture in enemy occupied territory,” and to “collect and distribute information.”³²⁷ The principal doctrinal publication, the classified *MI9 Bulletin* which was the “Bible” of Evasion and Escape, contained everything that could assist personnel who found themselves cut off in enemy territory or captured in Europe. The bulletin was updated as new information and experiences from escapers and evaders became available after successful recovery operations and debriefings.³²⁸ The U.S. equivalent to the MI9 was the Military Intelligence Service-X (MIS-X), which produced a similar publication called *The M.I.S.-X Manual on Evasion, Escape, and Survival*.³²⁹ In addition to the main

³²⁷ War Office, *Attachment “A,”* 4.

³²⁸ For the recently declassified WWII MI9 documents, see War Office, *MI9 Bulletin*; and War Office, *Attachment “A.”*

³²⁹ For the U.S. equivalent to the MI9, see War Department, *MIS-X Manual on Evasion, Escape, and Survival* (Washington, DC: War Department, 1944).

doctrinal publications of MI9 and M.I.S.-X, several unclassified survival guides covering land and sea survival in climates like the arctic, desert, and jungle were produced.³³⁰ The focus of WWII doctrine was on briefing the individual on personal survival skills and escape and evasion tactics.³³¹

Korea (June 25, 1950–July 27, 1953). When the Korean War broke out in June 1950, the available doctrine was still focused on the isolated personnel level and survival, and escape and evasion.³³² During the Korean War, several documents based on the experiences and lessons learned from the thousands of WWII escaper and evader debriefing reports were published by the Arctic, Desert, Tropic Information Center at the Air University (ADTIC) .³³³

Of the 1,600,000 U.S. service members that participated in the conflict, 7,190 became POWs, and of those, only 4,428 survived.³³⁴ The POW situation received a great deal of negative publicity in the United States, and the Defense Advisory Committee on Prisoners of War was tasked by the secretary of defense to investigate the situation, identify lessons learned, and initiate any necessary changes. Their recommendations are summarized in the opening remarks of their report.³³⁵

³³⁰ For examples of the various survival guides, see Office of Naval Intelligence, *Survival on Land and Sea* (Washington, DC: Government Printing Office, 1943); Air Ministry, *Health Hints for Warm Climates*, A.M. Pam 160 (London: Air Ministry, 1943); and Headquarters Army Air Forces, *Survival: On Land Jungle-Desert-Arctic*, AAF Manual No. 21W (New York: Army Air Forces Tactical Center, 1944).

³³¹ The individual survival doctrine focused on topics like first aid, fire-making, signaling, and water and food in general and specifically how the various environments influenced the same topics. The escape and evasion doctrine covered how to Escape and Evade in specific countries and how to break out of prison camps.

³³² After WWII, the focus continued to be on survival and Escape and Evasion techniques with updated and new publications based on the WWII experience, like Department of the Army, *Behind Enemy Lines*, DA Pam 21-46 (Washington, DC: U.S. Government Printing Office, 1951).

³³³ The ADTIC at the Air University researched and produced a range of lessons-learned documents based on actual survival stories from WWII to mitigate the risk to future isolated personnel in the same environments. Examples of this effort are found in Arctic, Desert, Tropic Information Center, *It's the Little Things: Evasion and Escape during World War II (S)*, ADTIC Publication No. G-100 (Maxwell, AL: Air University, 1950); Arctic, Desert, Tropic Information Center, *999 Survived: Survival Experiences in the Southwest Pacific*, ADTIC Publication No. T-100 (Maxwell, AL: Air University, 1950); and in Arctic, Desert, Tropic Information Center, *Afoot in the Desert: A Contribution to Basic Survival*, ADTIC Publication No. D-100 (Maxwell, AL: Air University, 1951).

³³⁴ Secretary of Defense Advisory Committee on Prisoners of War, *POW: The Fight Continues after the Battle* (Washington, DC: U.S. Government Printing Office, 1955), 79.

³³⁵ *Ibid.*

In concluding, the Committee unanimously agreed that Americans require a unified and purposeful standard of conduct for our prisoners of war backed up by a first class training program. This position is also wholeheartedly supported by the consensus of opinion of all those who consulted with the Committee. From no one did we receive stronger recommendations on this point than from former American prisoners of war in Korea—officers and enlisted men.³³⁶

The Korean POW experience triggered a major doctrinal change at the strategic level addressing the needs of the individual, when in August 1955, Dwight D. Eisenhower signed into effect Executive Order 10631, Code of Conduct for Members of the Armed Forces of the United States.³³⁷ The executive order stated:

All members of the Armed Forces of the United States are expected to measure up to the standards embodied in this Code of Conduct while in combat or in captivity. To ensure achievement of these standards, members of the armed forces liable to capture shall be provided with specific training and instruction designed to better equip them to counter and withstand all enemy efforts against them, and shall be fully instructed as to the behavior and obligations expected of them during combat or captivity.³³⁸

In sum, the Korean War experience and the immediate aftermath left the following PR policy in place by 1959. The doctrine was aimed at the individual level and the isolated personnel's SERE training and education. In order of publication: Exec. Order No. 10, 631--*Code of Conduct for members of the Armed Forces of the United States*, 3 C.F.R. (1954-1958); Department of the Air Force. *Survival* (AFM 64-5). Washington, DC: Air Training Command, 1954; Department of the Air Force. *Survival Training Edition* (AFM 64-3). Washington, DC: Air Training Command, 1956.; Department of the Army. *Survival* (FM 21-76). Washington, DC: U.S. Government Printing Office, 1957 C1, 1959; Department of the Army. *Evasion and Escape* (FM 21-77). Washington, DC: U.S. Government Printing Office, 1958, and Department of the

³³⁶ Ibid, vii.

³³⁷ For Executive Order 10631, see Executive Order 10631, "Code of Conduct for Members of the Armed Forces of the United States," August 17, 1955, as amended, <http://www.archives.gov/federal-register/codification/executive-order/10631.html>. For an in-depth study of the origins and meaning of the Code of Conduct, see Geoffrey S. Moakley, "U.S. Army Code of Conduct Training: Let the POWs Tell Their Stories" (master's thesis, United States Army Command and General Staff College, 1976).

³³⁸ See Executive Order 10631, "Code of Conduct."

Army. (C) *Evasion and Escape* (U) (FM 21-77A). Washington, DC: U.S. Government Printing Office, 1959.

Vietnam (1961–1975). During the Vietnam War, service-level PR doctrine evolved, and by the end of the war, several PR doctrine publications were updated, and new service-level doctrine for CSAR was established. Individual level doctrine to support the isolated personnel was updated several times in all services, covering topics on survival and escape and evasion skills.³³⁹

The new education and training in support of isolated personnel relied on doctrine that established a new Department of Defense–level directive to Code of Conduct training in the Department of Defense, *Training and Education Measures Necessary to Support the Code of Conduct (CoC)*.³⁴⁰

The development of combat search and rescue in Korea and Vietnam finally also led to a new service-level doctrine aimed at PR forces and commanders and staffs when the Department of the Army, the Air Force, and the Navy, *Wartime Search and Rescue* (AR 525-90, AFM 64-3, NWP 19-2), was established.³⁴¹

Desert Storm (1991–2000). Not until PR lessons learned from Desert Storm in 1991 did PR doctrine develop more than just updates from previous doctrine. The next step up the doctrine ladder came out of the Iraq conflict. By 1996, the first PR Joint Publications were established. In 1996, both the Joint Staff, *Joint Doctrine for Evasion*

³³⁹ The AFM 64-3 was updated twice as seen in Department of the Air Force, *Survival Training Edition*, AFM 64-3 (Washington, DC: Air Training Command, 1962), and in Department of the Air Force, *Survival Training Edition*, AFM 64-3 (Washington, DC: Air Training Command, 1969). The same update was made to AFM 64-5, as seen in Department of the Air Force, *Survival*; and in Department of the Air Force, *Survival: Search and Rescue*, AFM 64-5 (Washington, DC: Air Training Command, 1969). The Army also updated both the unclassified and the classified version of Field Manual 21-76 and FM 21-77, as seen in Department of the Army, *Survival Evasion and Escape*, FM 21-76 (Washington, DC: U.S. Government Printing Office, 1963); Department of the Army, *Survival Evasion and Escape*, FM 21-76 (Washington, DC: U.S. Government Printing Office, 1969); and the classified versions of Department of the Army, *Evasion and Escape*, FM 21-77 (Washington, DC: U.S. Government Printing Office, 1965); and the multiservice, Department of the Air Force, the Army, and the Navy, *(S) Joint Worldwide Evasion and Escape Manual (U)*, FM 21-77A (Washington, DC: Department of the Air Force, the Army, and the Navy, 1967).

³⁴⁰ Department of Defense, *Training and Education Measures Necessary to Support the Code of Conduct (CoC)*, DOD Directive 1300.7 (Washington, DC: Department of Defense, 1964).

³⁴¹ Department of the Army, the Air Force, and the Navy, *Wartime Search and Rescue*, AR 525-90, AFM 64-3, NWP 19-2 (Washington, DC: Government Printing Office, 1971).

and Recovery (JP 3-50.3) and the Joint Staff, *Doctrine for Joint Combat Search and Rescue* (JP 3-50.2) were published. In 1998, they were followed by the Joint Staff, *Joint Tactics, Techniques, and Procedures for Combat Search and Rescue* (JP 3-50.21).³⁴² These joint publications provided a common anchor point and an authoritative doctrinal framework that embraced all the services.

The joint publications were soon followed by a DOD Directive³⁴³ and DOD Instruction,³⁴⁴ as well as a Chairman of the Joint Chiefs of Staff Instruction³⁴⁵ that introduced the term *Personnel Recovery* (PR) for the first time as an umbrella term, defined it, and expanded upon PR as the following:

Personnel Recovery (PR). The sum of military, civil, and political efforts to obtain the release or recovery of personnel from uncertain or hostile environments and denied areas whether they are captured, missing, or isolated. That includes U.S., allied, coalition, friendly military, or paramilitary, and others as designated by the National Command Authorities (NCAs). PR is the umbrella term for operations that are focused on the task of recovering captured, missing, or isolated personnel from danger. PR includes, but is not limited to, theater search and rescue (SAR); Combat Search and Rescue (CSAR); Survival, Escape, Resistance, and Evasion (SERE); Evasion and Recovery (E&R); and the coordination of negotiated as well as forcible recovery options. PR may occur through military action, action by non-governmental organizations, other U.S. Government–approved action, and/or diplomatic initiatives, or through any of those options.³⁴⁶

The responsibilities for PR outlined in these documents were further expanded and updated in 2000, when DOD Directive 2310.2, *Personnel Recovery*, updated policy

³⁴² In order of appearance, see CJCS, *Doctrine for Joint Combat Search and Rescue*; CJCS, *Joint Doctrine for Evasion and Recovery*; and CJCS, *Joint Tactics, Techniques, and Procedures for Combat Search and Rescue*.

³⁴³ Deputy Secretary of Defense, *Personnel Recovery*, DOD Directive 2310.2 (Washington, DC: Deputy Secretary of Defense, 1997).

³⁴⁴ Under Secretary of Defense for Policy, *Personnel Recovery Response Cell (PRRC) Procedures*, DoD Instruction 2310.3 (Washington, DC: Under Secretary of Defense for Policy, June 30, 1997).

³⁴⁵ CJCS, *Personnel Recovery within the Department of Defense*, CJCS Instruction 3270.01 (Washington, DC: CJCS, January 1998).

³⁴⁶ Under Secretary of Defense for Policy, *Personnel Recovery Response Cell (PRRC) Procedures*, 6.

and realigned important responsibilities for PR.³⁴⁷ The DOD Directive for PR designates the commander in chief (CINC), United States Joint Forces Command (USJFCOM), as the DOD executive agent (EA) for PR and the Joint Personnel Recovery Agency (JPRA) as the OPR for DOD-wide personnel recovery.³⁴⁸ The directive provided a detailed account of the responsibilities of a number of important PR actors like the under secretary of defense for Policy, the assistant secretary of defense for Special Operations and Low Intensity Conflict, the secretary of the Air Force, the chairman of the Joint Chiefs of Staff, the commander of the Combatant Commands, and many more.

Personnel recovery policy and doctrine have evolved from the early days of WWII, but it took over six decades before President George W. Bush established a whole-of-government approach to PR. On December 4, 2008, he established Annex 1 to National Security Presidential Directive 12 (NSPD-12), *United States Policy on Personnel Recovery and the Prevention of U.S. Hostage Taking and Other Isolating Events*, and thereby lay the foundation for the development of a holistic government approach to PR.³⁴⁹ According to Lieutenant Colonel William J. Rowell, Annex 1 was a watershed effort in that it “[established] a comprehensive policy concerning personnel recovery with enabling objectives and specific tasks, guiding every department and agency toward three strategic personnel recovery objectives: prevention of, preparation for, and response to isolating events.”³⁵⁰ Rowell further highlighted that the strategic objective of response to an isolating event “is to energize the personnel recovery network and quickly recover isolated personnel and manage their reintegration into normal operations.”³⁵¹ The continuing efforts to improve the whole of government approach to PR was restated and reaffirmed when President Obama, in his press release on PPD-30 and the subject of U.S. nationals taken hostage abroad and personnel recovery efforts, stated,

³⁴⁷ Deputy Secretary of Defense, *Personnel Recovery*, DOD Directive 2310.2 (Washington, DC: Deputy Secretary of Defense, 2000).

³⁴⁸ *Ibid.*, 1.

³⁴⁹ Rowell, “Whole of Government Approach to Personnel Recovery.”

³⁵⁰ *Ibid.*, 9.

³⁵¹ *Ibid.*, 10.

The policy directs a renewed, more agile United States Government response to hostage-takings of U.S. nationals and other specified individuals abroad. It establishes processes to enable consistent implementation of the policies set forth in this directive, to ensure close interagency coordination in order to employ all appropriate means to recover U.S. hostages held abroad, and to significantly enhance engagement with hostages' families. It also reaffirms the United States Government's personnel recovery policy, which seeks to prevent, prepare for, and respond to hostage-takings and other circumstances in which U.S. nationals are isolated from friendly support.³⁵²

In sum, the evolution of U.S. PR doctrine can be traced back to its origins in WWII, and through a continuous evolution, the U.S. military and finally the President has gradually produced doctrine that ranges from the individual level through service, joint, and DOD-level guidance and finally has resulted in a whole of U.S. government approach to PR with strategic policy and guidance.

NATO doctrine on PR has been evolving through numerous study drafts since 2004. The first Allied Joint Doctrine (AJP) that discussed PR as an overarching system was the AJP-3.3.8 Initial Discussion Draft titled *Personnel Recovery Policy/Doctrine*. From 2004 until 2008, NATO PR doctrine evolved and changed names and numbering several times until it was called AJP-3.3.9 (SD-8) *Allied Joint Doctrine for Personnel Recovery*.³⁵³ The development of NATO PR TTPs followed a similar evolution of study drafts from 2005 until 2010 when it was called Allied Tactical Publication (ATP) 3.7.1 (SD-2) *NATO Personnel Recovery TTPs*.³⁵⁴ Because the study drafts were not formally approved NATO doctrine and awaited agreement on policy, a Joint Operational Guideline (JOG) was created that enabled NATO nations to educate and train according to an interim document until a final NATO PR policy emerged.³⁵⁵ Several NATO nations

³⁵² Barack Obama, *U.S. Nationals Taken Hostage Abroad and Personnel Recovery Efforts*, PPD-30 (Washington, DC: The White House, 2015); White House, Office of the Press Secretary, "Presidential Memorandum: Presidential Policy Directive—Hostage Recovery Activities," The White House, June 24, 2015, <https://www.whitehouse.gov/the-press-office/2015/06/24/presidential-policy-directive-hostage-recovery-activities>.

³⁵³ See Joint Air Power Competence Centre, *Personnel Recovery: That Others May Live to Return with Honor, A Primer* (Kalkar, Germany: JPCC, 2011), 14, Figure 2.

³⁵⁴ Joint Air Power Competence Centre, *Personnel Recovery*, 19, Figure 4.

³⁵⁵ NATO, *BI-SC Joint Personnel Recovery Joint Operational Guidelines*.

and other European countries have updated their PR documents, represented by Great Britain³⁵⁶ and Sweden.³⁵⁷ In addition to NATO work on PR, the European Air Group (EAG) has also been working European Union (EU) PR issues to foster PR collaboration among EU nations. The Joint Air Power Competence Centre (JAPCC) has published two major analyses on NATO PR to support the advance of NATO PR doctrine.³⁵⁸ Finally on February 23, 2016, the *Allied Joint Doctrine for Recovery of Personnel in a Hostile Environment* (AJP-3.7) was approved and put into effect.³⁵⁹ In addition to AJP-3.7, Allied Command Operations (ACO) Directive 080-101, *Personnel Recovery in NATO Operations*, established responsibilities for PR for NATO-led operations.³⁶⁰ To prevent an operational void, the ACO Manual 080-071, *Personnel Recovery in NATO Operations*, bridged the gap in NATO TTPs and served as a frame of reference until an ATP for PR could be written, ratified, and promulgated throughout NATO.³⁶¹

To sum up, in 2016, NATO finally has an overarching PR doctrine in place as AJP-3.7. It provides the fundamental principles of PR and aligns itself with the U.S. PR system model with minor modifications. Such an overarching doctrine is necessary for a multinational force to facilitate unity of effort and enhance PR efforts and provides a central NATO PR reference that allows NATO nations to develop their own national PR doctrine in accordance with a NATO-approved doctrine.

³⁵⁶ Ministry of Defense, *Joint Personnel Recovery*.

³⁵⁷ Forsvarsmakten [Swedish Armed Forces], *Handbok Joint Personnel Recovery* [Joint personnel recovery handbook] (Stockholm: Forsvarsmakten [Swedish Armed Forces], 2014).

³⁵⁸ Joint Air Power Competence Centre, *Personnel Recovery*; Joint Air Power Competence Centre, *Enhancing NATO Joint Personnel Recovery Capability: Education and Training* (Kalkar, Germany, May 2014), <https://www.japcc.org/?s=personnel+recovery>.

³⁵⁹ NATO, *Allied Joint Doctrine for Recovery of Personnel*.

³⁶⁰ NATO, *Personnel Recovery in NATO Operations*, ACO Directive 080-101 (Mons, Belgium: Supreme Headquarters Allied Powers Europe, 2015).

³⁶¹ *Ibid.*, 1.

APPENDIX G. ROBERTS NETWORK DESIGN FRAMEWORK

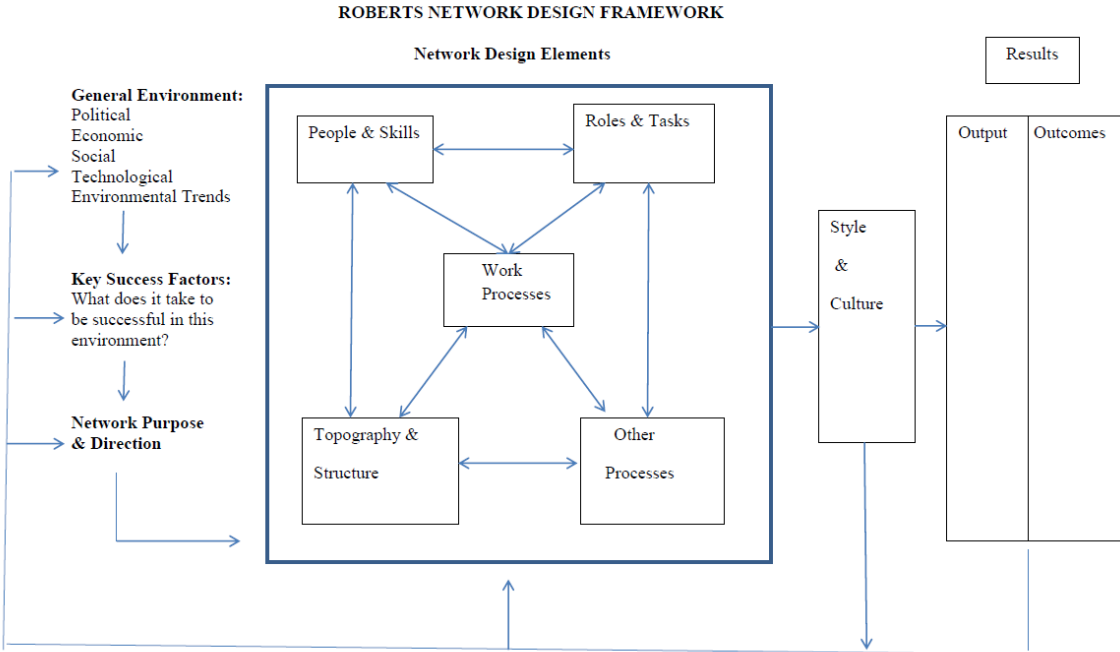

THIS PAGE INTENTIONALLY LEFT BLANK

LIST OF REFERENCES

- Adams, Thomas K. *U.S. Special Operations Forces in Action: The Challenge of Unconventional Warfare*. London: Frank Cass, 1998.
- Air Ministry. *Health Hints for Warm Climates*. A.M. Pam 160. London: Air Ministry, 1943.
- Alexander, Paul. "Fallout from Somalia Still Haunts U.S. Policy 20 Years Later." *Stars and Stripes*, October 3, 2013. <http://www.stripes.com/news/fallout-from-somalia-still-haunts-us-policy-20-years-later-1.244957>.
- Anderson, William C. *Bat-21*. Englewood Cliffs, NJ: Prentice-Hall, 1980.
- Anklam, Patti. *Net Work: A Practical Guide to Creating and Sustaining Networks at Work and in the World*. New York: Butterworth-Heinemann, 2007.
- Arctic, Desert, Tropic Information Center. *999 Survived: Survival Experiences in The Southwest Pacific*. ADTIC Publication No. T-100. Montgomery, AL: Air University, 1950.
- Arctic, Desert, Tropic Information Center. *Afoot in The Desert: A Contribution to Basic Survival*. ADTIC Publication No. D-100. Montgomery, AL: Air University, 1951.
- Arctic, Desert, Tropic Information Center. *It's The Little Things: Evasion and Escape during World War II (S)*. ADTIC Publication No. G-100. Montgomery, AL: Air University, 1950.
- Ardant du Picq, Charles Jean Jacques. *Battle Studies: Ancient and Modern*. Harrisburg, PA: Military Service Publishing, 1947.
- Arquilla, John, and David Ronfeldt. *Networks and Netwars*. Santa Monica: RAND Corporation, 2001.
- Baldwin, R. E., and Thomas McGarry. *Last Hope: The Blood Chit Story*. Atglen, PA: Schiffer, 1997.
- Berg-Knutsen, Espen, and Nancy Roberts. *Strategic Design for NORSOF 2025*. Naval Postgraduate School Technical Report No. NPS-DA-15-001. Monterey, CA: Naval Postgraduate School, September 2014.
- Bishop, Edward. *The Guinea Pig Club*. London: Macmillan & Co, 1963.
- Bishop, Edward. *McIndoe's Army: The Story of the Guinea Pig Club and its Indomitable Members*. London: Grub Street, 2001.

- Bottoms, Mike. "USSOCOM Celebrates Its 20th Anniversary." *Tip of the Spear* (April 2007): 4–10.
- Bowden, Mark. *Black Hawk Down: A Story of Modern War*. New York: Atlantic Monthly Press, 1999.
- Brinton, William Cope. *Graphic Presentation*. New York: Brinton Associates, 1939.
- Brome, Vincent. *The Way Back: The Story of Lieut.-Commander Pat O'Leary G.C., D.S.O., R.N.* London: Casel and Co, 1957.
- Brown, Tim. *Change by Design: How Design Thinking Transforms Organizations and Inspires Innovation*. New York: Harper Collins, 2009.
- Bush, George W. *United States Citizens Taken Hostage Abroad*. NSPD-12. Washington, DC: The White House, 2002.
- Caine, Philip D. *Aircraft Down!: Evading Capture in WWII Europe*. Washington, DC: Brassey's, 1997.
- Cambridge, Darren, Soren Kaplan, and Vicky Suter. *Communities of Practice Design Guide: A Step-by-Step Guide for Design & Cultivating Communities of Practice in Higher Education*. Washington, DC: EDUCAUSE Learning Initiative, 2005. <http://www.educause.edu/library/resources/community-practice-design-guide-step-step-guide-designing-cultivating-communities-practice-higher-education>.
- Carney, John T., and Benjamin F. Schemmer. *U.S. Special Operations Forces*. Tampa, FL: Hugh Lauter Levin Associates, 2003.
- Chairman, Joint Chiefs of Staff. *Doctrine for Joint Combat Search and Rescue*. JP 3-50.2. Washington, DC: CJCS, 1996.
- Chairman, Joint Chiefs of Staff. *DOD Dictionary of Military and Associated Terms*. JP 1-02. Washington, DC: CJCS, 2016.
- Chairman, Joint Chiefs of Staff. *Personnel Recovery*. JP 3-50. Washington, DC: CJCS, 2007.
- Chairman, Joint Chiefs of Staff. *Personnel Recovery*. JP 3-50. Washington, DC: CJCS, 2011.
- Chairman, Joint Chiefs of Staff (CJCS). *Personnel Recovery within the Department of Defense*. CJCS Instruction 3270.01. Washington, DC: Chairman of the Joint Chiefs of Staff, January 1998.
- Chairman, Joint Chiefs of Staff. *Special Operations*. Joint Publication 3–05. Washington, DC: CJCS, July 2014.

- Cohen, Don, and Laurence Prusak. *In Good Company: How Social Capital Makes Organizations Work*. Boston: Harvard Business School Press, 2001.
- Couch, Jon. *Caged Heroes: American POW Experiences from the Revolutionary War to the Present*. Bloomington, IN: AuthorHouse, 2011.
- Denning, Peter J. and Robert Dunham. *The Innovator's Way: Essential Practices for Successful Innovation*. London: The MIT Press, 2010.
- Department of the Air Force. *Survival*. AFM 64-5. Washington, DC: Air Training Command, 1945.
- Department of the Air Force. *Survival: Search and Rescue*. AFM 64-5. Washington, DC: Air Training Command, 1969.
- Department of the Air Force. *Survival Training Edition*. AFM 64-3. Washington, DC: Air Training Command, 1962.
- Department of the Air Force. *Survival Training Edition*. AFM 64-3. Washington, DC: Air Training Command, 1969.
- Department of the Air Force, the Army, and the Navy. *(S) Joint Worldwide Evasion and Escape Manual (U)*. FM 21-77A. Washington, DC: Department of the Air Force, the Army, and the Navy, 1967.
- Department of the Army. *Behind Enemy Lines*. DA Pam 21-46. Washington, DC: U.S. Government Printing Office, 1951.
- Department of the Army. *Evasion and Escape*. FM 21-77. Washington, DC: U.S. Government Printing Office, 1965.
- Department of the Army. *Survival Evasion and Escape*. FM 21-76. Washington, DC: U.S. Government Printing Office, 1963.
- Department of the Army. *Survival Evasion and Escape*. FM 21-76. Washington, DC: U.S. Government Printing Office, 1969.
- Department of the Army, the Air Force, and the Navy. *Wartime Search and Rescue*. AR 525-90, AFM 64-3, NWP 19-2. Washington, DC: Government Printing Office, 1971.
- Department of Defense. *Training and Education Measures Necessary to Support the Code of Conduct (CoC)*. DOD Directive 1300.7. Washington, DC: Department of Defense, 1964.
- Deputy Secretary of Defense. *Personnel Recovery*. DOD Directive 2310.2. Washington, DC: Deputy Secretary of Defense, 2000.

- Doll, John G. *Cloth Maps, Charts, and Blood Chits of World War II*. Bennington, VT: Merriam Press, 1988.
- Dorl, Thomas R. "Personnel Recovery and the DOTMLPF Changes Needed for the Twenty-First Century." Master's thesis, Joint Advanced Warfighting School, 2005.
- d.school. "The Design Process Mini-Guide." d.school. August 2, 2012.
https://dschool.stanford.edu/groups/designresources/wiki/36873/Design_Process_MiniGuide.html
- Dumais, Lucien. *The Man Who Went Back*. London: Leo Cooper, 1975.
- Durant, Michael J. *In the Company of Heroes*. New York: G. P. Putnam's Sons, 2003.
- Everton, Sean F. *Disrupting Dark Networks*. New York: Cambridge University Press, 2012.
- Fields, Kenny Wayne. *The Rescue of Streetcar 304: A Navy Pilot's Forty Hours on the Run in Laos*. Annapolis, MD: Naval Institute Press, 2007.
- Foot, M. R. D. *SOE in France: An Account of the Work of the British Special Operations Executive in France 1940–1944*. London: HSMO, 1966.
- Foot, M. R. D., and J. M. Langley. *MI9 Escape and Evasion 1939–1945*. London: The Bodley Head, 1979.
- Forsvaret [Norwegian Armed Forces]. *Direktiv for luftmilitær virksomhet* [Directive for air operations]. Oslo: Forsvarssjefen [Chief of defense], 2014.
- Forsvarsmakten [Swedish Armed Forces]. *Handbok Joint Personnel Recovery* [Joint personnel recovery handbook]. Stockholm: Forsvarsmakten [Swedish Armed Forces], 2014.
- Fowler, Will. *Certain Death in Sierra Leone: The SAS and Operation Barras 2000*. Oxford: Osprey Publishing Ltd., 2000.
- Franks, Norman. *Another Kind of Courage: Stories of the UK-Based Walrus Air-Sea Rescue Squadrons*. London: Patrick Stephens Limited, 1994.
- Freeman, Gregory A. *The Forgotten 500: The Untold Story of the Men Who Risked All for the Greatest Rescue Mission of World War II*. New York: NAL Calibel, 2007.
- Galdorisi, George, and Tom Phillips. *Leave No Man Behind: The Saga of Combat Search and Rescue*. Minneapolis: Zenith Press, 2008.

- Gargus, John. *The Son Tay Raid: American POWs in Vietnam Were Not Forgotten*. College Station, TX: Texas A&M University Press, 2007.
- Guilmartin, John F. *A Very Short War: The Mayaguez and the Battle of Koh Tang*. College Station, TX: Texas A&M University Press, 1995.
- Headquarters Army Air Forces. *Survival: On Land Jungle-Desert-Arctic*. AAF Manual No. 21W. New York: Army Air Forces Tactical Center, 1944.
- Hemingway-Douglas, Reanne, and Don Douglas. *The Shelbourne Escape Line: Secret Rescues of Allied Aviators by the French Underground, the British Royal Navy, and London's MI9*. Anacortes, WA: Cave Art Press, 2014.
- Holohan, Anne. *Networks of Democracy: Lessons from Kosovo for Afghanistan, Iraq, and Beyond*. Stanford: Stanford University Press, 2005.
- Holte, Nils Johan. "Norske spesialstyrker i støpesjeen—hva innebærer reformene?" [Norwegian Special Forces in development—what are the implications of reform?] Speech, Oslo Militære Samfund [Oslo Military Society], Oslo, March 31, 2014.
- Howarth, David. *The Shetland Bus: A WWII Epic of Escape, Survival, and Adventure*. Guilford, CT: The Lyon Press, 2001.
- Howarth, David. *We Die Alone: A WWII Epic of Escape and Endurance*. Guilford, CT: The Lyon Press, 1999.
- Hutton, Clayton. *Official Secret: The Remarkable Story of Escape Aids—Their Invention, Production—and the Sequel*. New York: Crown, 1961.
- Hutton, Clayton. *Per Ardua Libertas*. London: War Office, 1942.
- Ideo.org. *The Field Guide to Human-Centered Design*. San Francisco: Ideo.org., 2015.
- Ideo.org. *The Field Guide to Human-Centered Design: Design Kit*. Palo Alto, CA: IDEO.org, 2015. <http://www.designkit.org/resources/1>.
- Jackson, Mike, and Tara Dixon-Engel. *Naked in Da Nang: A Forward Air Controller in Vietnam*. St. Paul, MN: Zenith Press, 2004.
- Joint Air Power Competence Centre. *Enhancing NATO Joint Personnel Recovery Capability: Education and Training*. Kolkar, Germany: JPCC, May 2014.
- Joint Air Power Competence Centre. *Personnel Recovery: That Others May Live to Return with Honour, A Primer*. Kalkar, Germany: JPCC, 2011.

- Joseph, Dilip, and James Lund. *Kidnapped by the Taliban: A Story of Terror, Hope, and Rescue by Seal Team Six*. Nashville: W Publishing Group, 2014.
- Keeney, L. Douglas. *Air-Sea Rescue 1941–1952*. Campbell, CA: Premiere, 2013.
- Kenis, Patrick, and Keith G. Provan. “Towards an Exogenous Theory of Public Network Performance.” *Public Administration* 87, no. 3 (July 2009): 440–56. doi: 10.1111/j.1467-9299.2009.01775.x.
- Krippendorff, Klaus. *The Semantic Turn: A New Foundation for Design*. Boca Raton, FL: CRC Press, 2006.
- Kyle, James H., and John Robert Eidson. *The Guts to Try: The Untold Story of the Iran Hostage Rescue Mission by the On-Scene Desert Commander*. New York: Orion Books, 1990.
- Lineberry, Cate. *The Secret Rescue: An Untold Story of American Nurses and Medics behind Nazi Lines*. New York: Little, Brown and Company, 2013.
- Linstone, Harold A. *Multiple Perspectives for Decision Making: Bridging the Gap between Analysis and Action*. New York: Elsevier Science, 1984.
- Marrett, George J. *Cheating Death: Combat Air Rescues in Vietnam and Laos*. New York: Smithsonian Books, 2006.
- Martin, Roger. *The Design of Business*. Boston: Harvard Business Press, 2009.
- Matlary, Janne Haaland, Tormod Heier, and Ola Bøe-Hansen. *Strategisk Suksess?: Norsk Maktbruk i Libya og Afghanistan* [Strategic success?: Norwegian use of force in Libya and Afghanistan]. Oslo: Universitetsforlaget [University Press], 2013.
- Mayhew, E. R. *The Reconstruction of Warriors*. London: Greenhill Books, 2004.
- McChrystal, Stanley A., Tantum Collins, David Silverman, and Chris Fussell. *Team of Teams: New Rules of Engagement for a Complex World*. New York: Portfolio/Penguin, 2015.
- McDermott, Richard. “Why Information Technology Inspired, but Cannot Deliver Knowledge Management.” *California Management Review* 41, no. 3 (1999): 103–17.
- McNab, Andy. *Bravo Two Zero*. London: Bantam Press, 1993.
- McNab, Chris. *Storming Flight 181: GSG-9 and the Mogadishu Hijack 1977*. Oxford: Osprey, 2011.

- Mercer Delta Consulting. *The Congruence Model: A Roadmap for Understanding Organizational Performance*. New York: Mercer Delta Consulting, 2004.
- Milward, H. Brinton, and Keith G. Provan. *A Manager's Guide to Choosing and Using Collaborative Networks*. Washington, DC: IBM Center for the Business of Government, 2006.
<http://www.businessofgovernment.org/sites/default/files/CollaborativeNetworks.pdf>.
- Ministry of Defence. *Allied Joint Doctrine for Recovery of Personnel in a Hostile Environment*. Edition A, Version 1 with UK National Elements, AJP-3.7. London: Ministry of Defence, February 2016.
- Ministry of Defence. *Joint Personnel Recovery*. JWP 3-66. London: Ministry of Defence, 2003.
- Moakley, Geoffrey S. "U.S. Army Code of Conduct Training: Let the POWs Tell Their Stories." Master's thesis, United States Army Command and General Staff College, 1976.
- Neal, John A. *Bless You, Brother Irvin: The Caterpillar Club Story*. Ontario: General Store, 2005.
- Neave, Airey. *Little Cyclone*. London: Hodder and Stoughton, 1954.
- Neave, Airey. *Saturday at MI9: The Classic Account of the World War Two Allied Escape Organisation*. Barnsley, England: Leo Cooper, 2004.
- Nelson, Harold G., and Erik Stolterman. *The Design Way: Intentional Change in an Unpredictable World*. 2nd edition. London: The MIT Press, 2012.
- Neustadt, Richard E., and Ernest R. May. *Thinking in Time: The Uses of History for Decision-Makers*. New York: The Free Press, 1986.
- North Atlantic Treaty Organization. *Allied Joint Doctrine for Recovery of Personnel in a Hostile Environment*. AJP-3.7, Edition A, Version 1. Brussels: NATO Standardization Office, 2016.
- North Atlantic Treaty Organization. *BI-SC Joint Personnel Recovery Joint Operational Guidelines*. BI-SC JPR JOG. Norfolk, VA: Supreme Allied Commander, Transformation, 2011.
- North Atlantic Treaty Organization. *The NATO Survival, Evasion, Resistance and Extraction (SERE) Training Standard*. STANAG 7196 SD 05. Brussels: NATO Standardization Office, 2014.

- North Atlantic Treaty Organization. *The NATO Survival, Evasion, Resistance and Extraction (SERE) Training Standard*. STANAG 7196 SD 06. Brussels: NATO Standardization Office, 2016.
- North Atlantic Treaty Organization. *Personnel Recovery in NATO Operations*. ACO Directive 080-101. Mons, Belgium: Supreme Headquarters Allied Powers Europe, 2015.
- North Atlantic Treaty Organization. *Personnel Recovery in NATO Operations*. ACO Manual 080-071. Mons, Belgium: Supreme Headquarters Allied Powers Europe, 2016.
- Norwegian Armed Forces. *Norwegian Armed Forces in Transition: Strategic Defence Review by the Norwegian Chief of Defence*. Oslo: CHOD, 2015.
https://forsvaret.no/en/ForsvaretDocuments/Strategic_Defence_Review_2015_abbreviated.pdf.
- Obama, Barack. *U.S. Nationals Taken Hostage Abroad and Personnel Recovery Efforts*. PPD-30. Washington, DC: The White House, 2015.
- Office of Naval Intelligence. *Survival on Land and Sea*. Washington, DC: Government Printing Office, 1943.
- O’Grady, Scott, and Michael French. *Basher Five-Two: The True Story of F-16 Fighter Pilot Captain Scott O’Grady*. New York: Bantam Doubleday Dell, 1997.
- Pateman, Colin. *Goldfish, Caterpillars, & Guinea Pigs: Accounts of Pilots and Air Crews from the Second World War*. Oxford: Fonthill Media, 2012.
- Pera, Lee, Paul D. Miller, and Darrel Whitcomb. “Personnel Recovery: Strategic Importance and Impact.” *Air & Space Power Journal* (November-December 2012): 83–112.
- Peters, John, and John Nichol. *Tornado Down*. London: Signet, 1993.
- Phillips, Richard, and Stephan Talty. *A Captain’s Duty: Somali Pirates, Navy SEALs, and Dangerous Days at Sea*. New York: Hyperion, 2010.
- Pitchfork, Graham. *Shot Down and in the Drink: True Stories of RAF and Commonwealth Aircrews Saved from the Sea in WWII*. Richmond: The National Archives, 2005.
- Ratnam, Gopal. “The Islamic State Captures Jordanian Pilot after F-16 Crash.” *Foreign Policy*, December 24, 2014. <http://foreignpolicy.com/2014/12/24/the-islamic-state-may-have-just-shot-down-an-f-16-jet/>.
- Richardson, Dave. *Vietnam Air Rescues*. San Bernardino, CA: Dave Richardson, 2010.

- Riste, Olav. "With an Eye to History: The Origins and Development of 'Stay-Behind' in Norway." *Journal of Strategic Studies* 30, no. 6 (November 2007): 997–1024.
- Roberts, Nancy C. "Organizational Systems Framework." Working paper, Naval Postgraduate School, Monterey, CA, 2004.
- Rottman, Gordon L. *The Los Banos Prison Camp Raid: The Philippines 1945*. Oxford: Osprey, 2010.
- Rowell, William J. "Whole of Government Approach to Personnel Recovery." Master's thesis, United States Army War College, 2012.
- Ryan, Chris. *The One That Got Away*. London: Century, 1995.
- Scott, Astrid Karlsen, and Tore Haug. *Defiant Courage: A WWII Epic of Escape and Endurance*. New York: Skyhorse, 2010.
- Secretary of Defense Advisory Committee on Prisoners of War. *POW: The Fight Continues after the Battle*. Washington, DC: U.S. Government Printing Office, 1955.
- Shoemaker, Lloyd R. *The Escape Factory: The Story of MIS-X, The Super-Secret U.S. Agency behind World War II's Greatest Escapes*. New York: St. Martin's Press, 1990.
- Simpson, Ross W. *Stealth Down: The Loss of the First F-117 Stealth Fighter in Combat and the Dramatic Rescue of the Pilot*. Charleston, SC: Narwhal Press, 2003.
- Sutherland, Jon, and Diane Canwell. *The RAF Air Sea Rescue Service 1918–1986*. Barnsley, England: Pen & Sword Aviation, 2005.
- Taylor, L. B. *That Others May Live: The Aerospace Rescue and Recovery Service*. New York: E.P. Dutton & Co, 1967.
- Tilford, Earl H. *The United States Air Force: Search and Rescue in Southeast Asia*. Washington, DC: Center for Air Force History, 1992.
- Toliver, Raymond F. *The Interrogator: The Story of Hanns Scharff, Luftwaffe's Master Interrogator*. Fallbrook, CA: Aero Publishers, 1978.
- Under Secretary of Defense for Policy. *Non-Conventional Assisted Recovery in the Department of Defense*. DOD Instruction 2310.6. Washington, DC: Under Secretary of Defense for Policy, October 13, 2000.
- Under Secretary of Defense for Policy. *Personnel Recovery Response Cell (PRRC) Procedures*. DoD Instruction 2310.3. Washington, DC: Under Secretary of Defense for Policy, June 6, 1997.

- Vandenbroucke, Lucien S. *Perilous Option: Special Operations as an Instrument of U.S. Foreign Policy*. New York: Oxford University Press, 1993.
- Veith, George J. *Code Name Bright Light: The Untold Story of U.S. POW Rescue Efforts during the Vietnam War*. New York: The Free Press, 1998.
- Verity, Hugh. *We Landed by Moonlight: Secret RAF Landings in France, 1940–1944*. Wilmslow, England: AirData, 1995.
- War and Navy Departments. *A Pocket Guide to Netherlands East Indies*. Washington, DC: Government Printing Office, 1944.
- War Department. *Norwegian: A Guide to the Spoken Language*. TM 30-310. Washington, DC: U.S. Government Printing Office, 1943.
- War Department. *Norwegian Phrase Book*. TM 30-610. Washington, DC: U.S. Government Printing Office, 1943.
- War Office. *Attachment "A": Historical Record of MI9*. London: General Staff, 1945.
- War Office. *Enclosure II: Historical Record of RAF Intelligence Course "B."* London: General Staff, 1945.
- War Office. *MI9 Bulletin*. Copy 703. London: General Staff, 1945.
- War Office. *MI9 Evasion Reports*. London: General Staff, 1945.
- Wenger, Etienne, Richard McDermott, and William M. Snyder. *Cultivating Communities of Practice: A Guide to Managing Knowledge*. Boston: Harvard Business School Press, 2002.
- Wenger-Trayner, Etienne, Mark Fenton-O’Creevy, Steven Hutchinson, Chris Kubiak, and Beverly Wenger-Trayner. *Learning in Landscapes of Practice*. New York: Routledge, 2015.
- Wenger-Trayner, Etienne, Richard McDermott, and William M. Snyder. *Cultivating Communities of Practice: A Guide to Managing Knowledge*. Boston: Harvard Business School Press, 2002.
- Whitcomb, Darrel D. *The Rescue of Bat 21*. Annapolis, MD: Naval Institute Press, 1998.
- Whitcomb, Darrel D. *Combat Search and Rescue in Desert Storm*. Montgomery, AL: Air University Press, 2006.

White House, Office of the Press Secretary. “Presidential Memorandum: Presidential Policy Directive-Hostage Recovery Activities.” The White House, June 24, 2015. <https://www.whitehouse.gov/the-press-office/2015/06/24/presidential-policy-directive-hostage-recovery-activities>.

Wilson, David Sloan, and Edward O. Wilson. “Rethinking the Theoretical Foundations of Sociobiology.” *Quarterly Review of Biology* 82, no. 4 (2008): 327–48.

THIS PAGE INTENTIONALLY LEFT BLANK

INITIAL DISTRIBUTION LIST

1. Defense Technical Information Center
Ft. Belvoir, Virginia
2. Dudley Knox Library
Naval Postgraduate School
Monterey, California