



**Calhoun: The NPS Institutional Archive**

---

Faculty and Researcher Publications

Faculty and Researcher Publications Collection

---

1975-02

## Reliability analysis of phased missions

Esary, J.D.

Monterey, California. Naval Postgraduate School

---

<http://hdl.handle.net/10945/51495>



Calhoun is a project of the Dudley Knox Library at NPS, furthering the precepts and goals of open government and government transparency. All information contained herein has been approved for release by the NPS Public Affairs Officer.

**Dudley Knox Library / Naval Postgraduate School**  
**411 Dyer Road / 1 University Circle**  
**Monterey, California USA 93943**

<http://www.nps.edu/library>

AD-A008 290

RELIABILITY ANALYSIS OF PHASED MISSIONS

J. D. Esary, et al

Naval Postgraduate School  
Monterey, California

February 1975

DISTRIBUTED BY:

**NTIS**

National Technical Information Service  
U. S. DEPARTMENT OF COMMERCE

NAVAL POSTGRADUATE SCHOOL  
Monterey, California

Rear Admiral Isham Linder  
Superintendent

Jack R. Borsting  
Provost

This research was partially supported by the Office of Naval Research (NR 042-300) and the Strategic Systems Project Office (TA 19422).

This paper was prepared for presentation at the Conference on Reliability and Fault Tree Analysis, University of California (Berkeley), 3-7 September 1974.

Reproduction of all or part of this report is authorized.

ACCESSION for	
NTIS	White Section <input checked="" type="checkbox"/>
U. S.	Buff Section <input type="checkbox"/>
UNAN. CONTROL	<input type="checkbox"/>
DISTRIBUTION STATEMENT	
DISTRIBUTION STATEMENT OF THIS REPORT	
Dist. STATEMENT OF SPECIAL	
A	

Prepared by:

James D. Esary  
James D. Esary, Professor  
Department of Operations Research  
and Administrative Sciences

Harold Ziehms  
Harold Ziehms

Reviewed by:

David A. Schrady  
David A. Schrady, Chairman  
Department of Operations Research  
and Administrative Sciences

Released by:

Robert Fossum  
Robert Fossum  
Dean of Research



UNCLASSIFIED

SECURITY CLASSIFICATION OF THIS PAGE(When Data Entered)

Block 20 continued.

of a synthetic single phase case. The transformation has a potential for direct application, or can be used to study various computational algorithms and approximations.

UNCLASSIFIED

SECURITY CLASSIFICATION OF THIS PAGE(When Data Entered)

## Reliability Analysis of Phased Missions

J. D. Esary and H. Ziehms

Abstract. In a phased mission the relevant system configuration (block diagram or fault tree) changes during consecutive time periods (phases). Many systems are required to perform phased missions. A classic example is a space vehicle.

A reliability analysis for a phased mission encounters complexities not present with just one phase, but can be transformed into an analysis of a synthetic single phase case. The transformation has a potential for direct application, or can be used to study various computational algorithms and approximations.

1. Introduction. We consider a system which consists of several components. The components perform independently of each other, and each of them may be in one of two states, *functioning* or *failed*. It is assumed that no component can be repaired or replaced. Thus each component functions continuously in time until failure occurs, after which it remains failed. Esary and Marshall [1964] say that a device which displays this kind of behavior *has a life*.

The system performs a mission which can be divided into consecutive time periods, or *phases*. During each phase it has to accomplish a specified task. Thus the system *configuration* (a subset of the compo-

---

Department of Operations Research and Administrative Sciences, Naval Postgraduate School, Monterey, California 93940. This research was partially supported by the Office of Naval Research (NR 042-300) and the Strategic Systems Project Office (TA 19422).

nents and their functional organization which can be represented, for instance, by a block diagram or fault tree) changes from phase to phase. As is the case with individual components, only two states of the system are recognized, functioning or failed.

A classic example of a phased mission is the voyage of a space vehicle, but many other systems are required to perform phased missions. To illustrate the ideas and methods of this paper we will often consider the following hypothetical situation.

Example 1.1. A fire department has three vehicles;

- a multipurpose fire engine (M),
- a tanker (T),
- a light fire truck (L).

The firefighting equipment of a small chemical factory located nearby consists of;

- a sprinkler system (S),
- a hydrant (H),
- a special apparatus for fighting chemical fires (F).

The plant safety engineer wonders whether the combined hardware resources of the fire department and the factory are sufficient to fight a fire in the factory. He consults the fire chief, and together they conclude:

(1) During the initial stage of a fire either the multipurpose engine, which carries a small water supply, or the light truck, provided the sprinkler system works, suffices to evacuate the building.

(2) To contain the fire the factory's special apparatus is needed,

together with some auxiliary capability from the multipurpose engine or the light truck. Water can be supplied to the special apparatus and the department's units by the hydrant, or if it is out of order, by the tanker through pumps in the multipurpose engine.

(3) After the fire has been contained it can be controlled either by the special apparatus or the multipurpose engine. Again, water can be supplied by the hydrant or by the tanker together with the multipurpose engine.

The system has six components and has to perform a three-phased mission. □

Given the survival characteristics of the components, the relevant system configuration in each phase, and the duration of the phases, the problem is to find the probability that the system will function throughout the mission, i.e. the *mission reliability* for the system.

The reliability analysis of a phased mission encounters some complexities which are not present when only one phase is considered. It is not exact to do a standard analysis of each phase separately, and then multiply the resulting phase reliabilities together; even if the age of the components at the beginning of each phase is taken into account. The implicit assumption involved, that each component is functioning at the beginning of each phase, is not necessarily true. The following example illustrates this point.

Example 1.2. A system with two independent components,  $C_1$  and  $C_2$ , is designed for a two-phased mission. In order for the system to



perform the required tasks at least one component has to function through phase 1 and both components have to function through phase 2. The block diagram for this system is

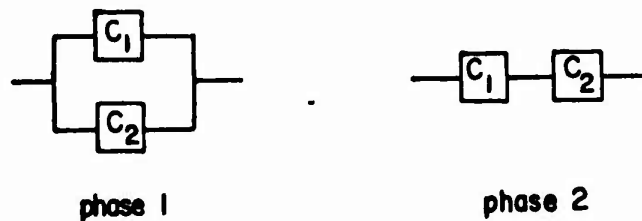

For  $k = 1, 2$ , let  $\pi_{k1}$  denote the probability that component  $C_k$  functions through phase 1, and  $\pi_{k2}$  denote the conditional probability that component  $C_k$  functions through phase 2, given that it has functioned through phase 1. The system reliability for phase 1 is  $\pi_1 = \pi_{11} + \pi_{21} - \pi_{11}\pi_{21}$ , and the system reliability for phase 2, given that both components have functioned through phase 1, is  $\pi_2 = \pi_{12}\pi_{22}$ . Multiplying these together would lead to the mission reliability

$$\pi = \pi_1\pi_2 = (\pi_{11} + \pi_{21} - \pi_{11}\pi_{21})\pi_{12}\pi_{22}$$

This is greater than the correct mission reliability, which is

$$P = \pi_{11}\pi_{12}\pi_{21}\pi_{22}$$

since mission success is achieved if, and only if, both components function through both phases.  $\square$

The multi-phase case is potentially different from the single-phase case in another respect. With just one phase, if each component has a life and the system configuration is *coherent* (representable by a

block diagram or fault tree using AND and OR gates), then the system has a life (Esary and Marshall [1964]). In the multi-phase case this is not necessarily true. Even if all components have lives and all phase configurations are coherent, the system may not have a life. How this can happen is shown in the next example.

Example 1.2. A two-component system is designed for a two-phase mission with the phase configurations represented by the block diagram



If  $\pi_{kj}$ ,  $k = 1, 2$ ,  $j = 1, 2$ , are defined as in Example 1.2, then there is a probability  $(1 - \pi_{11})\pi_{21}\pi_{22}$  that the system fails in phase 1, but functions again in phase 2. In this sense the system does not have a life.  $\square$

The possible resurrection of a system in a later phase does not present a problem in the reliability analysis of phased missions. Since failure of the system in even one phase prevents mission success, it will always be assumed that the life of the system ends at the time of its first failure. By contrast, the possible resurrection of a component would pose a much more serious problem, and is ruled out by the assumption that all components have lives.

The reliability analysis of phased missions has received attention in the basic papers of Rubín [1964] and Weisberg and Schmidt [1966].

These authors introduced a method of "cut cancellation" which can be advantageously used to simplify the sequence of phase configurations prior to beginning reliability calculations. More recently, a similar approach is described in the United States Navy reliability manual NAVORD OF 29304 Revision A [1973], based on the work of C. Persels.

The purpose of this paper is to exhibit a transformation which reduces any multi-phase mission to an equivalent, synthetic, single-phase system. Existing algorithms can then be applied to compute mission reliability. However, a concomitant apparent increase in the number of components may aggravate capacity problems. The transformation can also be used to study refined computational algorithms, and to derive bounds on mission reliability. Simple instances of its application are included.

2. Mathematical formulation of the phased mission problem. The system under consideration is assumed to have  $n$  components, labeled  $C_1, \dots, C_n$ . Each component  $C_k$  has a life and hence its *time to failure*, or *life length*, is a well defined, nonnegative random variable  $T_k$ . The assumption that the components perform independently of each other formally means that  $T_1, \dots, T_n$  are independent.

For each component  $C_k$  and all times  $t \geq 0$ , let  $X_k(t)$  be a Bernoulli random variable defined by

$$X_k(t) = \begin{cases} 1 & \text{if component } C_k \text{ functions at time } t, \text{ i.e.} \\ & \text{if } T_k > t, \\ 0 & \text{otherwise.} \end{cases}$$

The random variable  $X_k(t)$  is called a *performance state indicator variable*, and the stochastic process  $\{X_k(t), t \geq 0\}$  is the *performance process* of the component  $C_k$ . The sample paths of the latter have the properties that:

$$(2.1) \quad \begin{aligned} \text{a) } & X_k(t) = 0 \Leftrightarrow X_k(s) = 0, \quad s > t. \\ \text{b) } & X_k(t) = 1 \Leftrightarrow X_k(s) = 1, \quad 0 \leq s \leq t. \end{aligned}$$

Thus a sample path of a performance process is non-increasing and continuous from the right, as indicated in Figure 2.1.

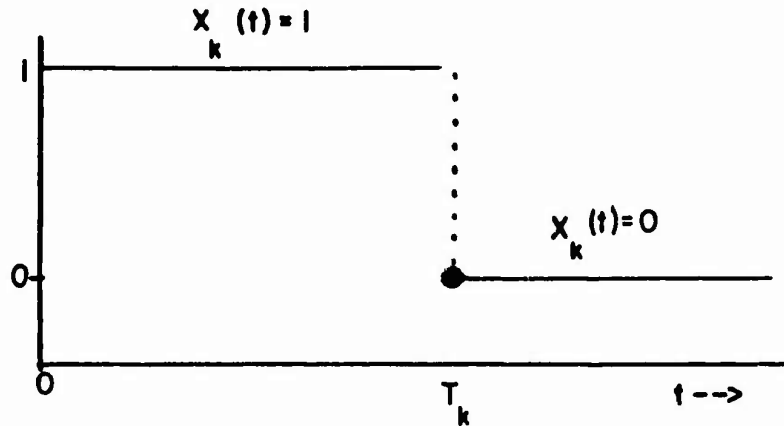

Figure 2.1. Performance process sample path, component  $C_k$ .

For each  $t \geq 0$ , let  $\underline{X}(t) = (X_1(t), \dots, X_n(t))$  be the *performance state indicator vector* of the set of components. Then the stochastic process  $\{\underline{X}(t), t \geq 0\}$  is called the *joint performance process* of the components.

The use of performance processes to represent component failure times is compatible with the use of structure functions to represent system configurations within phases.

The system configuration in each of the phases can be described by a block diagram or a fault tree for conceptual purposes, or by a structure function for mathematical analysis. A structure function is a binary function  $\phi$  of binary variables  $x_1, \dots, x_n$  which relates the performance state of the system to the performance states of its components; with  $\phi(\underline{x}) = \phi(x_1, \dots, x_n) = 1$  if the system functions, and  $\phi(\underline{x}) = 0$  otherwise, where  $x_k = 1$  if component  $C_k$  functions, and  $x_k = 0$  otherwise.

It is assumed that each phase configuration of a system is coherent, i.e. can be represented by a block diagram or fault tree using AND and OR gates. If a configuration is coherent, then its structure function  $\phi$  has the properties:

- (2.2) a)  $\phi(\underline{x}) \geq \phi(\underline{y})$  whenever  $x_k \geq y_k, k = 1, \dots, n.$   
 b)  $\phi(\underline{0}) = \phi(0, \dots, 0) = 0.$   
 c)  $\phi(\underline{1}) = \phi(1, \dots, 1) = 1.$

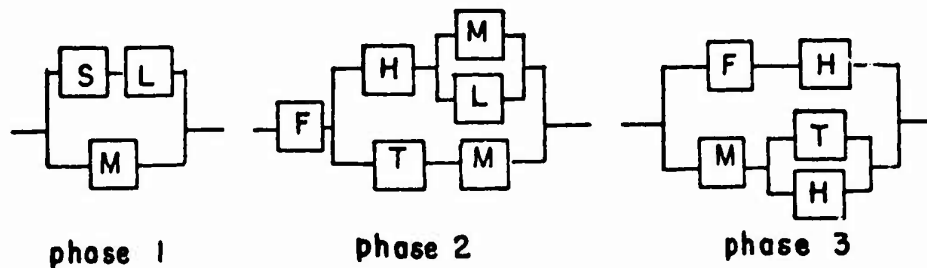

Figure 2.2. Block diagram for the mission of Example 1.1.

To illustrate, a block diagram for the mission described in Example 1.1 is shown in Figure 2.2, and a fault tree in Figure 2.3.

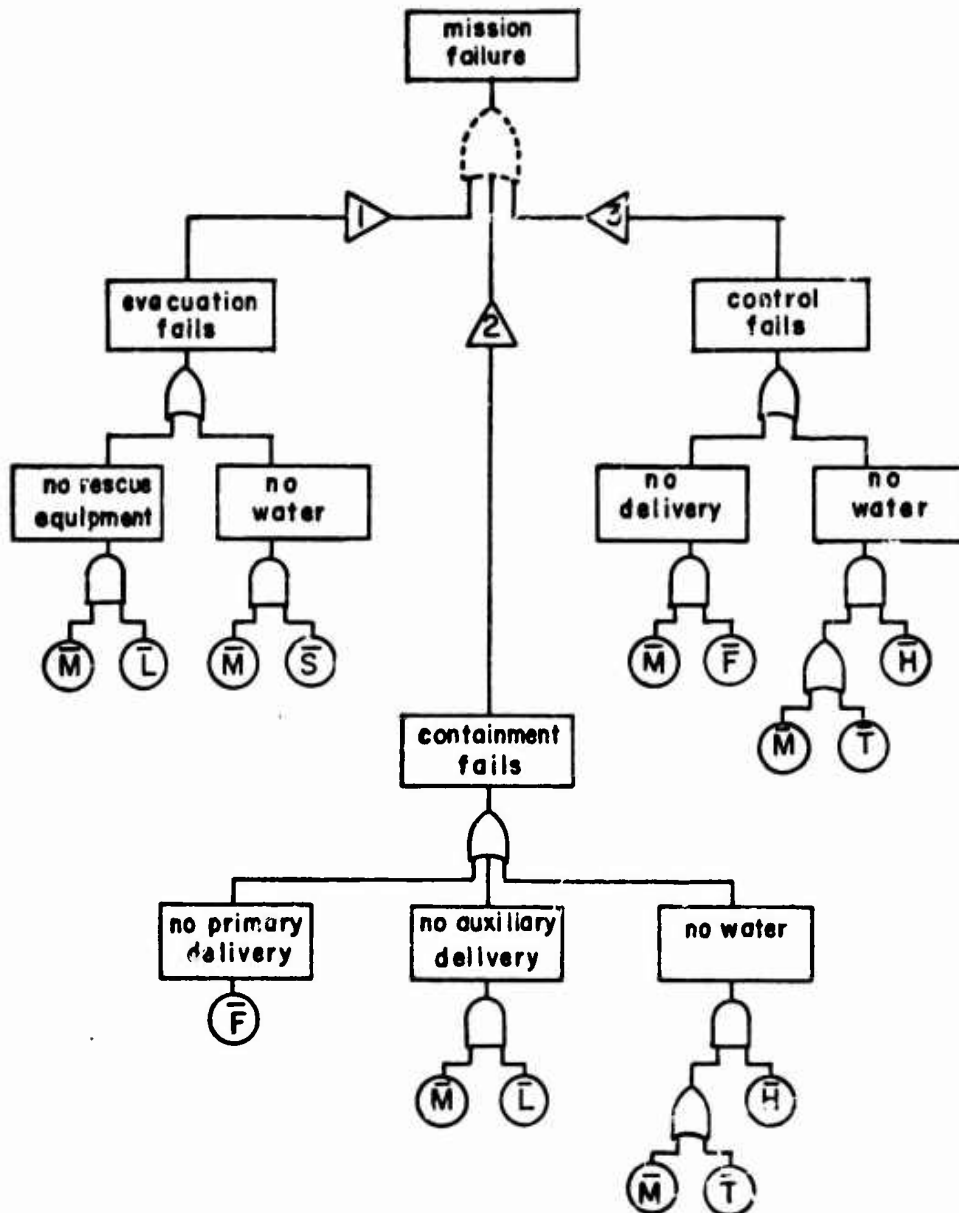

Figure 2.3. Fault tree for the mission of Example 1.1.

The structure functions for the system of Example 1.1 are;

$$\text{for phase 1, } \phi_1 = x_M \vee x_L x_S,$$

$$\text{for phase 2, } \phi_2 = x_F(x_H(x_M \vee x_L) \vee x_M x_T),$$

$$\text{for phase 3, } \phi_3 = x_F x_H \vee x_M(x_T \vee x_H).$$

The symbol  $\vee$  is the arithmetic OR operator, i.e.

$$x_1 \vee x_2 = \begin{cases} 1 & \text{if } x_1 = 1 \text{ or } x_2 = 1, \\ 0 & \text{if } x_1 = 0 \text{ and } x_2 = 0, \end{cases}$$

$$\begin{aligned} \text{or for computational purposes, } x_1 \vee x_2 &= x_1 + x_2 - x_1 x_2 \\ &= 1 - (1 - x_1)(1 - x_2). \end{aligned}$$

The phase structure functions can be combined with the component performance processes to achieve a concise mathematical formulation of the phased mission problem.

The mission is assumed to be divided into  $m$  phases, and to start at time  $t = 0$ . For  $j = 1, \dots, m$ , the time at which phase  $j$  ends, and, except for  $j = m$ , the next phase begins is denoted by  $t_j$ . The structure function appropriate for phase  $j$  is denoted by  $\phi_j$ . The event that the system functions during phase  $j$  can be expressed as  $\{\phi_j(\underline{X}(t_j)) = 1\}$ , and the event that the system functions throughout the mission by  $\{\phi_1(\underline{X}(t_1)) = 1, \dots, \phi_m(\underline{X}(t_m)) = 1\}$ . The mission reliability for the system is the probability that this event occurs. Since  $\phi_j(\underline{X}(t_j))$ ,  $j = 1, \dots, m$ , are Bernoulli random variables, this probability may be expressed compactly as

$$(2.3) \quad p = P\left[\prod_{j=1}^m \phi_j(\underline{X}(t_j)) = 1\right] = E \prod_{j=1}^m \phi_j(\underline{X}(t_j)),$$

where  $E$  denotes expectation.

The fact reflected in (2.3), that the sequential operation of phase configurations resembles to some extent the serial operation of subsystems, is important in transforming the phased mission problem.

3. Transformation of a multi-phase mission into a single-phase mission. Complexities in the reliability analysis of phased missions arise because a component's performance in each phase depends on its performance in previous phases. The dependence, however, is of a special type. A component functions in phase  $j$  if, and only if, it has previously functioned in phase 1, and in phase 2, ..., and in phase  $j-1$ , and then functions in phase  $j$ . This sequence of requirements suggests that the performance of a component in phase  $j$  can be represented by a series-like structure whose elements represent its performance in phases 1, ...,  $j$ .

To be more specific, suppose that component  $C_k$  is replaced by phase  $j$  by a system of components  $C_{k1}, \dots, C_{kj}$ , performing independently and in series. In block diagram format, the block



is replaced in phase  $j$  by

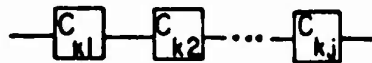

In fault tree format, the input event  $\bar{C}_k$  (failure of component  $C_k$ ) is replaced in phase  $j$  by



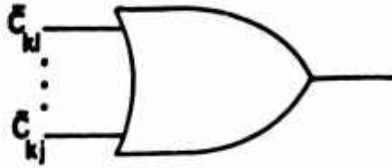

Let  $U_{k1}, \dots, U_{kj}$  be independent performance state indicator variables for the components  $C_{k1}, \dots, C_{kj}$ , with

$$(3.1) \quad \begin{aligned} P[U_{k1} = 1] &= P[X_k(t_1) = 1] \\ P[U_{ki} = 1] &= P[X_k(t_i) = 1 | X_k(t_{i-1}) = 1], \quad i = 2, \dots, j. \end{aligned}$$

Then  $P[X_k(t_j) = 1] = P[U_{k1} U_{k2} \dots U_{kj} = 1]$ , and so

$$X_k(t_j) =^{st} U_{k1} U_{k2} \dots U_{kj},$$

where  $=^{st}$  means "is stochastically equal to" or, less formally, "has the same distribution as." Thus the original component and the substituted system have, as of the end of phase  $j$ , the same reliability.

The preceding observations suggest that a transformation of the phased mission problem can be accomplished by:

- (a) Replacing, in the configuration for phase  $j$ , component  $C_k$  by a series system in which the components  $C_{k1}, \dots, C_{kj}$  perform independently with the probabilities of functioning given in (3.1).
- (b) Considering the transformed phase configurations to be subsystems which operate in series.

The resulting new system, which has (at most)  $n \times m$  independent compo-

nents, is the equivalent system. As will be shown later, the ordinary reliability of the equivalent system is the same as the reliability of the original system for its phased mission.

As an illustration, the block diagram for the equivalent system arising out of Example 1.1 is shown in Figure 3.1 (cf. the block diagram for the phased mission shown in Figure 2.2).

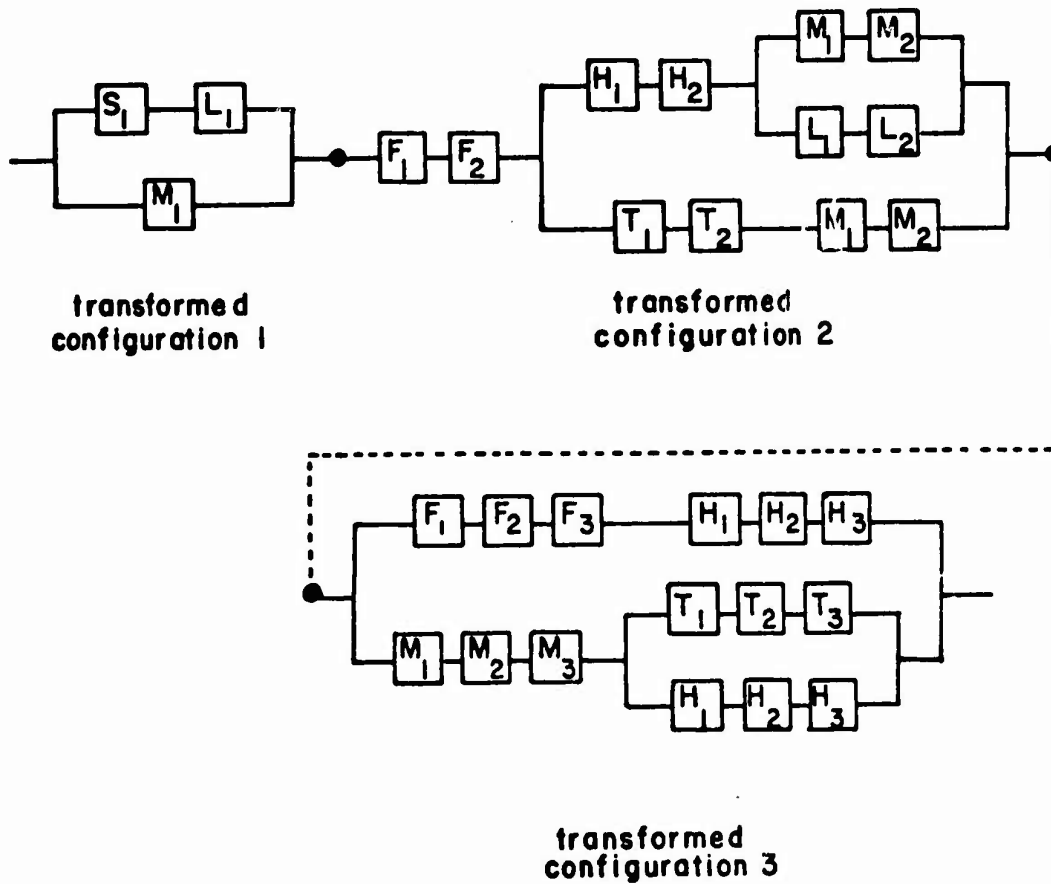
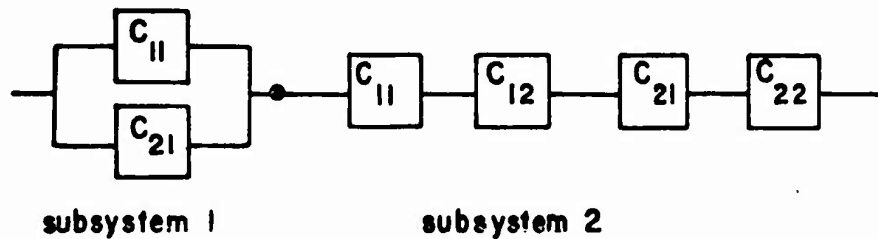

Figure 3.1. Equivalent system for the mission of Example 1.1.

In the equivalent system the  $m$  phase configurations which operated in sequence become  $m$  subsystems which operate in series. However, these subsystems usually have components in common (cf. Figure 3.1), and do not function independently. Thus the product of the subsystem reliabilities is in general not equal to the system reliability, as is illustrated by the following extension of Example 1.2.

Example 3.1. For the mission described in Example 1.2, the equivalent system has the block diagram



Letting  $\pi_{kj}$ ,  $k = 1, 2$ ,  $j = 1, 2$ , be as defined in Example 1.2, and  $\rho_{k1} = \pi_{k1}$ ,  $\rho_{k2} = \pi_{k1}\pi_{k2}$ ,  $k = 1, 2$ , the subsystem reliabilities are

$$\rho_1 = \pi_{11} + \pi_{21} - \pi_{11}\pi_{21} = \rho_{11} + \rho_{21} - \rho_{11}\rho_{21},$$

$$\rho_2 = \pi_{11}\pi_{12}\pi_{21}\pi_{22} = \rho_{12}\rho_{22}.$$

Their product  $\rho = \rho_1\rho_2$  is, except in trivial cases, less than the true system reliability  $p = \pi_{11}\pi_{12}\pi_{21}\pi_{22} = \rho_{12}\rho_{22}$  which can be found by reducing the block diagram to its simplest form



The true reliability for the equivalent system does agree with the reliability for the phased mission given in Example 1.2.  $\square$

The transformed version of the phase  $j$  configuration functions if the event  $\{\phi_j(\underline{u}^{(1)} \underline{u}^{(2)} \dots \underline{u}^{(j)}) = 1\}$  occurs, where  $\underline{u}^{(i)} = (U_{1i}, \dots, U_{ni})$ , and  $\underline{u}^{(i)} \underline{u}^{(l)} = (U_{1i} U_{1l}, \dots, U_{ni} U_{nl})$ . The equivalent system functions if the event  $\{\phi_1(\underline{u}^{(1)}) = 1, \phi_2(\underline{u}^{(1)} \underline{u}^{(2)}) = 1, \dots, \phi_m(\underline{u}^{(1)} \underline{u}^{(2)} \dots \underline{u}^{(m)}) = 1\}$  occurs. The reliability of the equivalent system is

$$\begin{aligned} p &= P\{\prod_{j=1}^m \phi_j(\underline{u}^{(1)} \underline{u}^{(2)} \dots \underline{u}^{(j)}) = 1\} \\ (3.2) \quad &= E\prod_{j=1}^m \phi_j(\underline{u}^{(1)} \underline{u}^{(2)} \dots \underline{u}^{(j)}). \end{aligned}$$

It remains to establish that the reliability of the equivalent system agrees with the mission reliability for the original system, i.e. that  $p$  as given by (3.2) agrees with  $p$  as given by (2.3). This is done by the following theorem and subsequent remarks.

Theorem 3.1. Let  $X_1, \dots, X_m$  be a non-increasing sequence of Bernoulli random variables, i.e.  $X_1 \geq X_2 \geq \dots \geq X_m$ . Let  $U_1, \dots, U_m$  be independent Bernoulli random variables with

$$P\{U_1 = 1\} = P\{X_1 = 1\},$$

$$P\{U_j = 1\} = P\{X_j = 1 | X_{j-1} = 1\}, \quad j = 2, \dots, m.$$

Then  $X_1, \dots, X_m \stackrel{st}{=} U_1, U_1 U_2, \dots, U_1 U_2 \dots U_m$ .

Proof. It is only necessary to show for each non-increasing

binary sequence  $x_1 \geq x_2 \geq \dots \geq x_m$ ,  $x_j = 0$  or  $1$ ,  $j = 1, \dots, m$ , that

$$P[X_1 = x_1, \dots, X_m = x_m] = P[U_1 = x_1, U_1 U_2 = x_2, \dots, U_1 U_2 \dots U_m = x_m].$$

For the sequence  $x_1 = 0, x_2 = 0, \dots, x_m = 0$ ,

$$\begin{aligned} P[X_1 = 0, \dots, X_m = 0] &= P[X_1 = 0] = P[U_1 = 0] \\ &= P[U_1 = 0, U_1 U_2 = 0, \dots, U_1 U_2 \dots U_m = 0]. \end{aligned}$$

For the sequence  $x_1 = 1, x_2 = 1, \dots, x_m = 1$ ,

$$\begin{aligned} P[X_1 = 1, \dots, X_m = 1] &= P[X_m = 1 | X_{m-1} = 1] \dots \\ &\quad \dots P[X_2 = 1 | X_1 = 1] P[X_1 = 1] \\ &= P[U_m = 1] \dots P[U_2 = 1] P[U_1 = 1] \\ &= P[U_1 = 1, U_1 U_2 = 1, \dots, U_1 U_2 \dots U_m = 1]. \end{aligned}$$

For any other sequence  $x_j = 1$ ,  $j = 1, \dots, \ell$ ,  $x_j = 0$ ,  $j = \ell+1, \dots, m$ ,

$$\begin{aligned} P[X_1 = 1, \dots, X_\ell = 1, X_{\ell+1} = 0, \dots, X_m = 0] &= P[X_m = 0, \dots, X_{\ell+1} = 0 | X_\ell = 1, \dots, X_1 = 1] \\ &\quad \times P[X_\ell = 1, \dots, X_1 = 1] \\ &= P[X_{\ell+1} = 0 | X_\ell = 1] P[X_\ell = 1, \dots, X_1 = 1] \\ &= P[U_{\ell+1} = 0] P[U_\ell = 1, \dots, U_1 = 1] \\ &= P[U_1 = 1, \dots, U_\ell = 1, U_{\ell+1} = 0] \\ &= P[U_1 = 1, U_1 U_2 = 1, \dots, U_1 U_2 \dots U_\ell = 1, \dots \\ &\quad \dots, U_1 \dots U_\ell U_{\ell+1} = 0, \dots, U_1 U_2 \dots U_m = 0]. \quad \square \end{aligned}$$

From (2.1) the sequence of variables  $X_k(t_1), \dots, X_k(t_m)$ , which indicate the performance of component  $C_k$  at the end of each phase, is non-increasing. Thus for  $U_{k1}, \dots, U_{km}$  constructed according to (3.1),

$$X_k(t_1), X_k(t_2), \dots, X_k(t_m) \stackrel{st}{=} U_{k1}, U_{k1} U_{k2}, \dots, U_{k1} U_{k2} \dots U_{km}.$$

Then, since component failure times, and consequently component performance processes, are independent,

$$\underline{X}(t_1), \underline{X}(t_2), \dots, \underline{X}(t_m) \stackrel{st}{=} \underline{U}^{(1)}, \underline{U}^{(1)} \underline{U}^{(2)}, \dots, \underline{U}^{(1)} \underline{U}^{(2)} \dots \underline{U}^{(m)}.$$

Since the event "success in the phased mission" occurs if

$\phi_j(\underline{X}(t_j)) = 1$ ,  $j = 1, \dots, m$ , and the event "functioning of the equivalent system" occurs if  $\phi_j(\underline{U}^{(1)} \underline{U}^{(2)} \dots \underline{U}^{(j)}) = 1$ ,  $j = 1, \dots, m$ , then these two events are stochastically equivalent. Thus  $p$  as given by (2.3) agrees with  $p$  as given by (3.2).

4. Sample applications of the transformation. The transformation described in Section 3 provides, in principle, a way to adapt existing programs for computing the reliability of single-phase systems to the computation of mission reliabilities for phased missions. The necessary inputs are the phase configurations and, phase by phase, the conditional probabilities that the components survive the phase, given that they have survived the previous phases, i.e. the component *conditional phase reliabilities*

$$(4.1) \quad \begin{aligned} r_{k1} &= P[X_k(t_1) = 1], \\ r_{kj} &= P[X_k(t_j) = 1 | X_k(t_{j-1}) = 1], \quad j = 2, \dots, m, \end{aligned}$$

$k = 1, \dots, n$ . From (3.1) the conditional phase reliabilities are the reliabilities of the components in the equivalent system. The program could be adapted to accomplish steps (a) and (b) of the transformation internally, and then to find the reliability of the equivalent system.

Direct implementation of the transformation could be frustrated by a large number of components in the equivalent system, and in any case may not be the most efficient approach. However, the transformation may also be used to study refined computational algorithms, and bounds on mission reliability.

For instance, it is possible to study the tempting procedure of estimating mission reliability by computing the reliability of each phase configuration separately, and then multiplying the results together. There are at least two choices of component reliabilities to use in doing this; the conditional phase reliabilities given in (4.1), or the component (unconditional) reliabilities through each phase

$$(4.2) \quad \rho_{k,j} = P\{X_k(t_j) = 1\} = \prod_{i=1}^j \pi_{ki}, \quad j = 1, \dots, m,$$

$k = 1, \dots, n$ . The first choice leads to estimating mission reliability by

$$(4.3) \quad \pi = \prod_{j=1}^m h_j(\pi_{1j}, \dots, \pi_{nj}),$$

and the second choice to estimating mission reliability by

$$(4.4) \quad \rho = \prod_{j=1}^m h_j(\rho_{1j}, \dots, \rho_{nj}),$$

where in both cases  $h_j, j = 1, \dots, m$ , are the reliability functions

for the phase configurations. The reliability function of a system with structure function  $\phi$  is defined by

$$h(p_1, \dots, p_n) = P[\phi(X_1, \dots, X_n) = 1] = E\phi(X_1, \dots, X_n),$$

where  $X_1, \dots, X_n$  are independent Bernoulli random variables with  $P[X_k = 1] = p_k$ ,  $k = 1, \dots, n$ .

The following remark shows that (4.3) gives an optimistic result (cf. Example 1.2) and that (4.4) gives a conservative result (cf. Example 3.1).

Remark 4.1. For  $\pi$  as given by (4.3),  $\rho$  as given by (4.4), and  $p$  as given by (2.3) or (3.2),  $\rho \leq p \leq \pi$ .

Proof. The coherent phase configurations have non-decreasing structure functions from (2.2), and  $\underline{u}^{(1)}, \dots, \underline{u}^{(n)}$  are independent by construction. Thus

$$\begin{aligned} E \prod_{j=1}^m \phi_j(\underline{u}^{(1)} \underline{u}^{(2)} \dots \underline{u}^{(j)}) &\leq E \prod_{j=1}^m \phi_j(\underline{u}^{(j)}) \\ &= \prod_{j=1}^m E \phi_j(\underline{u}^{(j)}), \end{aligned}$$

so that  $p \leq \pi$  from (3.2) and (4.3).

The proof that  $\rho \leq p$  uses standard properties of associated random variables (Barlow and Proschan [1975], Chapter 2, or Esary, Proschan, and Walkup [1967]). Since  $U_{kj}$ ,  $k = 1, \dots, n$ ,  $j = 1, \dots, m$ , are independent, and thus associated, and  $\phi_j$ ,  $j = 1, \dots, m$ , are non-decreasing, then  $\phi_j(\underline{u}^{(1)} \underline{u}^{(2)} \dots \underline{u}^{(j)})$ ,  $j = 1, \dots, m$ , are associated. Therefore the inequality



$$\prod_{j=1}^m E \phi_j(\underline{u}^{(1)} \underline{u}^{(2)} \dots \underline{u}^{(j)}) \leq E \prod_{j=1}^m \phi_j(\underline{u}^{(1)} \underline{u}^{(2)} \dots \underline{u}^{(j)})$$

holds, so that  $\rho \leq p$  from (4.4) and (3.2).  $\square$

The transformation can provide a simple rationale for the cut cancellation technique of Rubin, Weisberg, and Schmidt. Conversely, cut cancellation can result in an advantageous simplification of the earlier configurations of a phased mission, prior to any implementation of the transformation.

For instance, the sequence of phase configurations in Example 1.2 turned out to have the mission reliability  $p = \rho_{12}\rho_{22}$ . The sequence of phase configurations

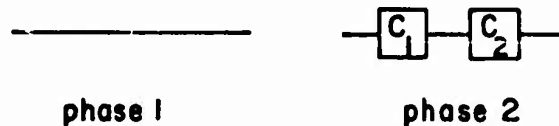

has the same mission reliability. In Example 1.2 the only minimal cut set in phase 1,  $\{C_1, C_2\}$ , contains the phase 2 minimal cut sets,  $\{C_1\}$  and  $\{C_2\}$ . Thus  $\{C_1, C_2\}$  can be "cancelled" in its phase, leaving a configuration which can never fail.

The *minimal cut sets* of a (coherent) phase configuration are the minimal (in the sense of set inclusion) combinations of components which by all failing cause the configuration to fail. The configuration can be viewed as a series combination of subconfigurations, each of which consists of the components in a minimal cut set acting in parallel (Barlow and Proschan [1975], Chapter 1, or Birnbaum, Esary, and



It is easy to verify that both sequences lead to the same mission reliability by comparing their equivalent systems.  $\square$

The use of cut cancellation is justified by the following remark.

Remark 4.2. *Cut cancellation does not affect mission reliability.*

Proof. A formal proof of the remark could be given without invoking the transformation, but its use provides a way to visualize why the remark is true, and further, why cut cancellation is not a symmetric procedure.

Simply note that a minimal cut set of the phase  $j$  configuration, consisting of the components, say  $C_1, \dots, C_\ell$ , corresponds to a parallel and series array

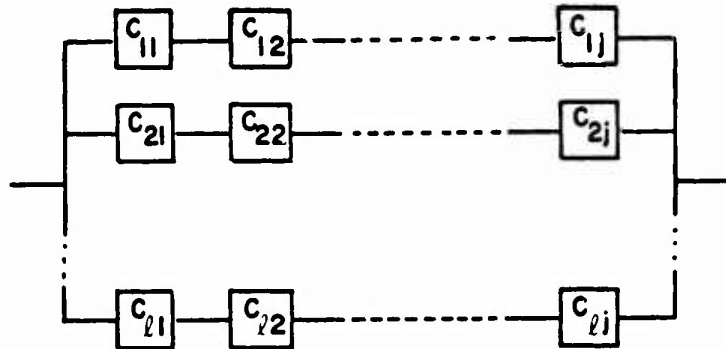

in the equivalent system. This array acts in a series with the similar arrays corresponding to the other minimal cut sets, whatever their phase of origin. Then it is apparent that a minimal cut set, which contains a minimal cut set from a later phase, can be cancelled with no effect.  $\square$

As a final illustration of the cut cancellation technique we can

consider its effect on the mission described in Example 1.1. The minimal cut sets for this mission are, before cancellation:

in phase 1      {M,L}    {M,S}

in phase 2      {F}    {H,M}    {H,T}    {M,L}

in phase 3      {F,M}    {H,M}    {H,T}

The minimal cut sets after cancellation are:

in phase 1      {M,S}

in phase 2      {F}    {M,L}

in phase 3      {F,M}    {H,M}    {H,T}

A block diagram for the simplified sequence of phase configurations is shown in Figure 4.1.

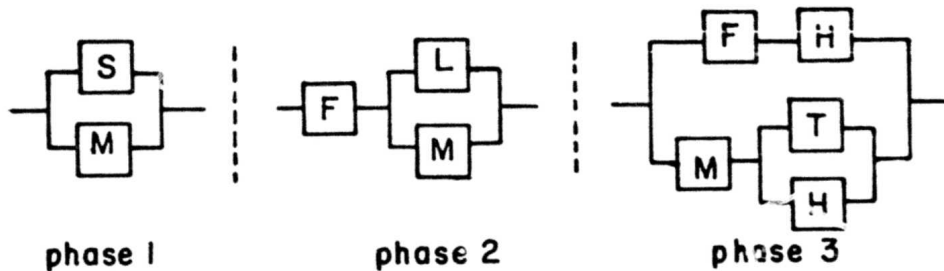

Figure 4.1. Phase configurations for the mission of Example 1.1 after cut cancellation.

After cancellation, the transformation could be applied to obtain an equivalent system simpler than the one shown in Figure 3.1. Reliability computations would be simplified accordingly.

#### REFERENCES

- [1] R. E. BARLOW and F. PROSCHAN, *Statistical Theory of Reliability and Life Testing. Volume I: Probability Models.* (1975). Holt, Rinehart and Winston.
- [2] Z. W. BIRNBAUM, J. D. ESARY and S. C. SAUNDERS, Multicomponent systems and structures and their reliability. *Technometrics* 3 (1961), 55-77.
- [3] J. D. ESARY and A. W. MARSHALL, System structure and the existence of a system life. *Technometrics* 6 (1964), 459-462.
- [4] J. D. ESARY, F. PROSCHAN and D. W. WALKUP, Association of random variables, with applications. *Ann. Math. Statist.* 38 (1967), 1466-1474.
- [5] J. C. RUBIN, The reliability of complex networks. *Proceedings of the Aero-space Reliability and Maintainability Conference* (1964).
- [6] S. A. WEISBERG and J. H. SCHMIDT, Computer technique for estimating system reliability. *Proceedings of the 1966 Annual Symposium on Reliability.* IEEE 7C26 (1966).
- [7] NAVORD OD 29304 Revision A, *Reliability Evaluation Program Manual.* U. S. Navy, Strategic Systems Projects Office (1973).