

# **Polymerase chain reaction-based national surveillance programme to determine the distribution and prevalence of *Taylorella equigenitalis* in South African horses**

C. E. May<sup>1,\*</sup>, A. J. Guthrie<sup>2</sup>, B. Keys<sup>3</sup>, C. Joone<sup>2</sup>, M. Monyai<sup>2</sup>

and M. L. Schulman<sup>1,\*</sup>

<sup>1</sup>Section of Reproduction, Department of Production Animal Studies, Faculty of Veterinary Science, University of Pretoria, Onderstepoort, South Africa

<sup>2</sup>Equine Research Centre, University of Pretoria, Onderstepoort, South Africa

<sup>3</sup>Companion Animal Clinical Studies Department, Faculty of Veterinary Science, University of Pretoria, Onderstepoort, South Africa

\*Correspondence emails: cmay1@sgu.edu; martin.schulman@up.ac.za

## **Summary**

### ***Reasons for performing study:***

The response to the first outbreak of contagious equine metritis in South Africa included pioneering a web-based platform to coordinate key aspects of a national, real-time polymerase chain reaction (qPCR)-based stallion screening programme to determine the distribution and prevalence of *Taylorella equigenitalis* in stallions and exposed mares.

### ***Objectives***

To define the hypothesised pre-existing status of *T. equigenitalis* in the South African equine population and progression of the epidemiological investigation via the implementation of a molecular diagnostic-based surveillance programme.

### ***Study design***

Retrospective case series.

### ***Methods***

Screening for *T. equigenitalis* was via a qPCR assay on genital swabs obtained from predilection sites in stallions and mares with subsequent confirmation using bacterial culture according to prescribed methods.

## Results

The initial outbreak investigation identified 4 horses including the index stallion and mare. Traceback of in-contact horses identified 26 horses, including a subpopulation focus at the South African Lipizzaner Centre where 24/33 resident stallions tested positive for *T. equigenitalis* on qPCR. The national screening programme identified an additional 9 stallions. A total of 39 horses (36 stallions and 3 mares) tested positive for *T. equigenitalis* by qPCR and *T. equigenitalis* was isolated from 23 of these stallions and 2 of these mares. In addition to the index property, an artificial breeding centre where the index case was first identified, an additional 12 properties with infected horses were identified in 3/9 provinces. Horses on 11 of these 12 properties were directly linked to the index property. Two incidents of *T. equigenitalis* transmission associated with artificial insemination were recorded.

## Conclusions

*T. equigenitalis* was present in a subpopulation focus within the South African horse population prior to the outbreak identification in April 2011. Horizontal fomite-associated spread was the most probable route of transmission between stallions. The targeted surveillance of stallions and exposed mares using a qPCR-based screening programme expedited investigation of the distribution and prevalence of *T. equigenitalis* infection in South African horses. The application of qPCR provided a sensitive and practical screening test for identification of *T. equigenitalis*-positive animals as part of an emergency response to the first identified cases of *T. equigenitalis* infection in South African horses.

## Keywords:

horse; fomite transmission; qPCR ; *Taylorella equigenitalis*

## Introduction

*Taylorella equigenitalis* is a nonmotile, microaerophilic Gram-negative, frequently pleiomorphic bacterium [1, 2] that causes contagious equine metritis (CEM), a nonsystemic, venereally transmitted disease of horses. *T. equigenitalis* is spread directly during natural mating or artificial insemination (AI) with semen from a carrier stallion [3] and by indirect fomite transmission [3-5]. Affected stallions are unapparent carriers of the organism and are the principal source of infection. Carrier status may persist for months or years [5, 6] with the organism showing a tropism for the urethra, the urethral sinus and the *lamina interna* [7, 8]. Mares typically show a mucopurulent vaginal discharge and irregular interoestrus periods due to endometritis, cervicitis or vaginitis, or may show no clinical signs [6]. Most mares rid themselves of infection, developing a transient humoral antibody response, however, a small population of asymptotically infected mares may attain carrier status lasting for months or even years [8, 9]. A second, closely related member of the genus, *Taylorella asinigenitalis*, identified from donkey jacks is currently regarded as nonpathogenic in horses [10].

The current test recognised by the World Organisation for Animal Health (OIE) for *T. equigenitalis* for international trade purposes is bacterial culture. Swabs obtained from prescribed sites are transferred in charcoal Amies medium on ice to reach the reference laboratory within 48 h. *T. equigenitalis* is fastidious, slow growing and readily overgrown by other microorganisms present in the reproductive tract of horses thus affecting the sensitivity and utility of bacterial culture [9, 11]. Due to these associated difficulties, various real-time polymerase chain reaction (qPCR) assays have been developed to detect *T. equigenitalis* [11, 12] and to discriminate this species from *T. asinigenitalis* [13].

Since the first reported cases of CEM in Thoroughbred horses in the UK, the disease has been found to have a worldwide distribution [2, 3]. The most recent outbreaks in nonendemic countries include the 2008–2010 outbreak in the USA and the 2012 outbreak in Gloucestershire, UK [14, 15]. South Africa was considered free of CEM until 3 May 2011 when a suspected outbreak was confirmed. This paper describes the subsequent outbreak investigation and shows how molecular tools were utilised during a national surveillance programme and outbreak management.

## **Materials and methods**

### **Epidemiology**

#### *Background and outbreak identification*

The South African Veterinary Authority submitted an immediate notification report of an outbreak of CEM in South Africa to the OIE on 9 May 2011 (OIE reference: Immediate notification; 09/05/2011). The index case, a stallion released from post-arrival quarantine on 22 February 2011, was moved to an equine breeding centre in Gauteng Province where semen collection for AI resulted in initially successful embryo transfer (ET) from several mares. Subsequently, following unsuccessful ET attempts, genital swabs obtained from the stallion and a mare inseminated with his semen were reported as being suspect positive on culture for *T. equigenitalis* on 4 April 2011. Swabs from these cultures were submitted to an OIE reference laboratory (Animal Health and Veterinary Laboratory Agency, Bury St Edmunds, UK) and were confirmed positive for *T. equigenitalis* on 3 May 2011.

All in-contact horses at the breeding centre (index property) were traced, quarantined and sampled for *T. equigenitalis* testing. Two stallions that had indirect contact with the index case on the index property tested positive on a second property (OIE Reference: Follow-up report no. 1; 12/07/2011). A national screening programme was introduced on 31 August 2011 to facilitate investigation of the extent of *T. equigenitalis* infection within South Africa [16].

#### *National screening programme*

The South African Directorate of Animal Health instituted a national screening programme and issued an order effective from the 31 August 2011 that no stallion was allowed to be used for breeding without the issue of an official CEM clearance certificate after 2 negative qPCR tests for *T. equigenitalis* from genital swabs obtained  $\geq 7$  days apart according to

prescribed methods outlined in the legislation [16]. To facilitate compliance only offspring from stallions with a valid CEM clearance certificate were eligible for registration by their relevant breed society. The targeted surveillance of stallions was supported by the known pathogenesis of the organism and its reported persistence on the external genitalia of unapparent carrier stallions [6, 8]. The screening programme utilised qPCR for testing, with positive horses retested using a combination of qPCR and confirmatory bacterial culture.

#### *Traceback of horses in contact with positive stallions identified during the national screening programme*

Following identification in the Western Cape Province of a *T. equigenitalis*-positive Lipizzaner stallion originating from Gauteng Province, traceback screening of all stallions (n = 33) resident at the South African Lipizzaner Centre (SALC), Midrand, Gauteng was instituted and all stallions were swabbed in accordance with the prescribed method [16].

As part of a 1996 investigation of equine arteritis virus, semen samples had been collected from each of 7 seropositive Lipizzaner stallions [17]. Aliquots of the sperm-rich fraction of each collection were stored at -70 °C. These archived samples were accessed in August 2014, thawed and submitted for qPCR and culture as described below.

A traceback of mares commenced approximately 18 months after the index case was reported. Mares (n = 70) were classified as 'in-contact' if their associated data indicated being bred (by natural mating or assisted breeding) to a confirmed *T. equigenitalis*-positive stallion. An additional traceback of offspring (n = 46) resultant from breeding to *T. equigenitalis*-positive sires was conducted, based on the reported potential for vertical transmission [3]. All *T. equigenitalis*-positive animals were quarantined and treated according to the prescribed method [18].

#### *Collection of samples*

Standard dry swabs<sup>1</sup> were taken from each of the prescribed predilection sites. In stallions (after i.v. sedation to facilitate penile extrusion) these were: the distal urethra; urethral fossa; and preputial *lamina interna*. In mares these were: the clitoral fossa (standard dry swabs<sup>1</sup>); the clitoral sinuses (paediatric swabs<sup>2</sup>); and endometrium (double-guarded endometrial swab<sup>3</sup>). In animals identified as *T. equigenitalis*-positive on qPCR, a further set of swabs was collected from each site and transported in Amies charcoal medium stored at 2–8°C during transport to the laboratory for bacterial culture.

#### *Bacterial culture*

All swabs for bacterial culture were transferred to the Agricultural Research Council, Onderstepoort Veterinary Institute, Onderstepoort, Gauteng within 48 h of collection for culture according to the OIE Manual of Diagnostic Tests and Vaccines for Terrestrial Animals [19].

### *Real-time qPCR*

All swabs for qPCR testing were transferred to the Veterinary Genetics Laboratory, University of Pretoria. A Taqman PCR assay was used based on the method described by Wakeley *et al.* [13]. DNA was extracted from the dry swabs as described previously [13]. Minor modifications were made to both the primers and probes used in the assay to adapt the assay to efficient operation on the real-time PCR machine used in the laboratory (forward primer – TCGGGTTGTAAAGCACTTTTGTGTC, reverse primer – GCCGGTGCTTATTCTTCAGGTA, *T. equigenitalis* probe – FAM-TGTGTTAATACCATGGACTGC-MGB, and *T. asinigenitalis* probe –NED-TAGGATAATACCCTAGGATGC-MGB). The 17 µl PCR mix consisted of 2 µl of primer/probe mix, 5 µl of nuclease free water and 10 µl of Kapa Probe Fast ABI Prism 2 × PCR master mix4, which was added to each well of a PCR plate to which 3 µl of the extracted template was added. Positive and negative template controls were included on each plate. The PCR was performed according to the manufacturer's protocol on a StepOnePlus Real-Time PCR System5 and the cycle threshold ( $C_t$ ) was calculated as the point when the normalised fluorescence exceeded a 0.1 threshold within 40 PCR cycles.

### *Web-based platform*

This was developed to coordinate key aspects of the stallion screening programme ([www.cemsa.co.za](http://www.cemsa.co.za); Active: 1 August 2011 to 30 June 2014). The order pertaining to CEM including prescribed sampling protocols, submission instructions and forms and a list of certified *T. equigenitalis*-free stallions were available online for veterinarians, breeders and concerned parties.

### *Treatment protocol*

All *T. equigenitalis*-positive animals were quarantined and subsequently successfully treated according to the updated method prescribed in the legislation [18]. The initial treatment protocol was modified to include in-treatment qPCR assays to monitor treatment efficacy and point of organism elimination as experience gained during the initial outbreak response indicated a longer average treatment duration is required for successful elimination of *T. equigenitalis* [8].

## **Results**

Apart from animals identified on 2 properties in the initial outbreak investigation, *T. equigenitalis*-positive horses were identified on an additional 11 properties. The associated data are shown in Supplementary Item 1. Of the 4 horses identified in the initial outbreak investigation all tested positive on bacterial culture while samples from only 2 of the 4 were subjected to qPCR and tested positive.

During July 2011–July 2013, the national screening programme tested 3703 animals and identified 9 additional *T. equigenitalis*-positive stallions, a prevalence rate of 0.24% (9/3703) in the population tested (OIE Reference: Follow-up report No. 2 Outbreak 1, Outbreak 2, Outbreak 3, Outbreak 4, Outbreak 5; Follow-up report No. 3, Outbreak 1; Follow-up report

No. 4, Outbreak 1, Outbreak 2, Outbreak 4). All 9 horses tested positive on both qPCR and bacterial culture.

The traceback of in-contact horses identified a subpopulation focus at the SALC (n = 33) where 24 resident stallions tested positive for *T. equigenitalis* on qPCR, a prevalence of 72.7%, while 14 tested positive on bacterial culture (OIE Reference: Follow-up report No. 3 Outbreak 2). A total of 11 of the 33 resident stallions were reported to have been used for breeding by natural cover or AI. Ten of these 11 stallions tested positive for *T. equigenitalis* with 4 having visited the index property for semen collection since 2001. The Lipizzaner stallion identified in the Western Cape Province had also visited the index property for semen collection prior to relocation. Following their treatment and repatriation, monthly follow-up qPCR-testing of this subpopulation to monitor long-term status showed no recurrence after 24 months. The archived semen samples obtained in 1996 from the Lipizzaner stallions yielded 5/7 positive for *T. equigenitalis* on both qPCR and bacterial culture.

The traceback of in-contact mares (n = 70) and their offspring (n = 46) identified 2 *T. equigenitalis*-positive females: a prevalence of 1.72% (2/116; OIE Reference: Follow-up report No. 3 Outbreak 1, Follow-up report No.4 Outbreak 3). Both were transferred for treatment under quarantine at locations separate from their home properties. All 26 *T. equigenitalis*-positive horses identified during the traceback of in-contact horses tested positive on qPCR ( $C_t$  value range: 15.4–34.4) while 15 (58%) were positive, and 11 (42%) were negative on bacterial culture.

The countrywide prevalence of *T. equigenitalis* by testing was 0.97% (36/3703) in stallions and 2.56% (3/117 including index mare) in mares. Thirty-nine horses were identified positive for *T. equigenitalis* by qPCR screening with 28 being confirmed positive using bacterial culture.

A temporal schematic representation of *T. equigenitalis*-positive horses identified during the South African outbreak including the hypothesised transmission is shown in Figure 1.

## Discussion

The initial outbreak response identified the index stallion and mare and 2 additional stallions. The national screening programme and traceback of in-contact horses subsequently identified an additional 33 stallions and 2 mares. All positive cases with the exception of 2 horses were located in Gauteng Province. Eight of the 9 stallions identified by the national screening programme had visited the index property on multiple occasions. The ninth stallion was not linked to the index property, but had been previously stabled with Lipizzaner stallions.

The findings of the national screening programme and traceback of in-contact horses demonstrated that the index stallion was not the source of this outbreak. Records showed negative bacterial cultures for *T. equigenitalis* during both pre- and post importation

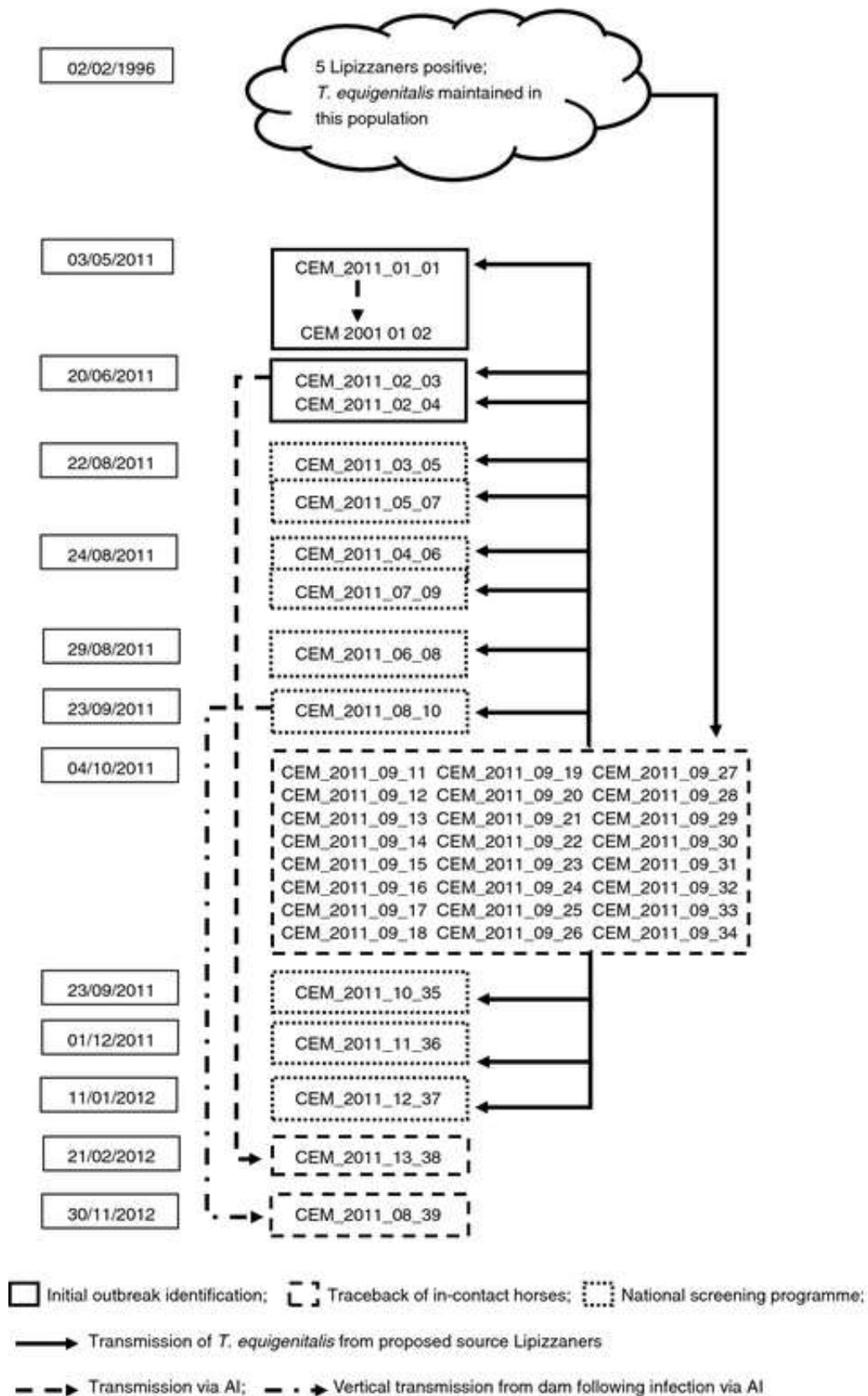

**Figure 1.** Schematic temporal representation of *T. equigenitalis*-positive horses in the South African outbreak with the proposed transmission between animals involved in the outbreak. Dates on the left represent the date of sample collection.

quarantine testing and an initially successful round of AI and ET preceded the observed genital infection later confirmed to be *T. equigenitalis*. More recently, archived semen samples collected in 1996 were shown to be positive for *T. equigenitalis* on bacterial culture and qPCR, indicating the organism's presence in South Africa prior to outbreak identification in April 2011. Several stallions from the SALC visited the index property for semen collection during 2001–2006; however, prior to this, the SALC had maintained a closed herd since the first introduction of Lipizzaners into South Africa in 1948. We propose that the infection persisted at the SALC, probably with ongoing transmission by fomites, since the organism was introduced into South Africa possibly as early as 1948. Thereafter, the index property was repeatedly contaminated during repeated visits by colonised stallions for semen collection with additional stallions becoming colonised by further fomite transmission and the infection becoming established outside of the Lipizzaner population. The candidate fomites included the breeding phantom, equipment or personnel during semen collection and handling, tack and grooming equipment [6, 7, 14]. No evidence of *T. equigenitalis* was detected among Lipizzaner mares and offspring at a satellite property. These factors support fomite transmission as the probable primary route of transmission among stallions resident at the SALC. The only confirmed venereal transmission of *T. equigenitalis* was associated with 2 mares inseminated with contaminated semen from known positive stallions. This finding is similar to that previously reported in the USA [14, 20].

Spontaneous resolution of infection and the organism's susceptibility to many physical and chemical agents has been previously described [3, 5, 8]. The relatively prolonged interval from potential exposure to traceback implementation makes it impossible to determine the total number of mares infected. Despite this, the identification of 2 positive mares linked to the positive stallions only by AI with contaminated semen highlights the importance of inclusion of exposed mares during targeted epidemiological surveillance of stallions [21].

Prior to the introduction of the national screening programme, a review of the laboratory resources available for bacterial culture and the anticipated time for transport of samples to the laboratory from remote areas in South Africa was performed. Due to the impracticality of transporting a large proportion of the samples from the collection points to the laboratory within 48 h and due to the limited laboratory capacity for bacterial culture it was decided to implement a qPCR assay for screening to overcome both the logistical issues associated with transport from remote sites and to provide the required laboratory capacity. Following the identification of 9 positive stallions in the national screening programme, special arrangements were made for the collection of samples for bacterial culture and for the direct transfer of these samples to the bacteriology laboratory within hours of collection (2–6 h). The qPCR and bacterial culture results from these samples were in full concordance.

In the case of the traceback of in-contact horses, all 26 tested positive on qPCR while 15 were positive on bacterial culture of a single set of samples. Based on the history, the risk of exposure of these horses was considered high and to expedite resolution of the outbreak in most cases treatment was initiated shortly after the animals were shown to be positive on qPCR and prior to the completion of the bacterial cultures. Furthermore, initiation of treatment precluded the collection of further samples for bacterial culture. Therefore, while these practical limitations could be partially responsible for the difference in detection rate



between qPCR and bacterial culture it has been reported that the sensitivity of qPCR exceeds that of bacterial culture [22].

The web-based platform coordinating key aspects of stallion screening was indispensable in disseminating information, ensuring compliance of stakeholders and providing a central database for data collation facilitating epidemiological investigation. Successful treatment of all positive horses supported redrafting of pertinent CEM legislation to include a derogation permitting the treatment of any infected equines subject to compliance with the legislation [18].

## **Conclusions**

This study showed that *T. equigenitalis* was present in the South African Lipizzaner population prior to outbreak identification in 2011. During the investigation of outbreaks targeted surveillance of stallions and their in-contact mares is recommended and qPCR provides a sensitive and logistically practical method for large *T. equigenitalis* surveillance programmes. A web-based platform coordinating a national stallion surveillance programme determined both the extent and prevalence of *T. equigenitalis* in a large heterogenous population of breeding stallions and provides an appropriate means for ongoing surveillance. Ongoing bacteriological surveillance of all horses entering assisted reproduction facilities is recommended despite the *T. equigenitalis* status of a country.

## **Authors' declaration of interests**

No competing interests have been declared.

## **Ethical animal research**

Ethical review and approval was granted by the National Department of Agriculture, Forestry and Fisheries.

## **Source of funding**

Funding for this study was provided by Equine Research Centre, University of Pretoria, South Africa and the Department of Agriculture, Forestry and Fisheries, Republic of South Africa.

## **Acknowledgements**

This outbreak investigation and management was made possible by the input, resources and funding of numerous stakeholders, including: Department of Agriculture, Forestry and Fisheries, Republic of South Africa; and the University of Pretoria's Section of Reproduction and Equine Research Centre. The cooperation of private veterinarians, breed societies and horse-owners was also crucial in the successful implementation of the national screening programme.

## Authorship

C.E. May contributed to study design, data collection, data analysis and interpretation, writing of manuscript, and final approval for publication. B. Keys contributed to data collection. C. Joone and M. Monyai contributed to technical laboratory assistance and processing of samples. A.J. Guthrie contributed to study design, data collection, data analysis and interpretation, writing of manuscript, and gave final approval for publication. M.L. Schulman contributed to study design, data collection, data analysis and interpretation, writing of manuscript, and gave final approval for publication.

## Manufacturers' addresses

1. Labchem (Pty) Ltd, Johannesburg, South Africa.
2. Copan Innovation, Brescia, Italy.
3. Easy Guard, Section of Reproduction, Onderstepoort, South Africa.
4. Kapabiosystems, Cape Town, South Africa.
5. Life Technologies, Carlsbad, California, USA.

## References

1. Ricketts, S.W. , Rossdale, P.D. , Wingfield-Digby, N.J. , Falk, M.M. , Hopes, R. , Hunt, M.D.N. and Peace, C.K. (1977) Genital infection in mares. *Vet. Rec.* 101, 65.
2. Timoney, P.J. , Ward, J. and Kelly, P. (1977) A contagious genital infection of mares. *Vet. Rec.* 101, 103.
3. Timoney, P.J. (2011) Horse species symposium: contagious equine metritis: An insidious threat to the horse breeding industry in the United States. *J. Anim. Sci.* 89, 1552-1560.
4. Aalsburg, A.M. and Erdman, M.M. (2011) Pulsed-field gel electrophoresis genotyping of *Taylorella equigenitalis* isolates collected in the United States from 1978 to 2010. *J. Clin. Microbiol.* 49, 829-833.
5. Schulman, M.L. , May, C.E. , Keys, B. and Guthrie, A.J. (2013) Contagious equine metritis: artificial reproduction changes the epidemiologic paradigm. *Vet. Microbiol.* 167, 2-8.
6. Timoney, P.J. and Powell, D.G. (1988) Contagious equine metritis – epidemiology and control. *J. Equine. Vet. Sci.* 8, 42-46.
7. Timoney, P.J. (1996) Contagious equine metritis. *Comp. Immunol. Microbiol. Infect. Dis.* 19, 199-204.
8. Luddy, S. and Kutzler, M.A. (2010) Contagious equine metritis within the United States: a review of the 2008 outbreak. *J. Equine. Vet. Sci.* 30, 393-400.
9. Matsuda, M. and Moore, J.E. (2003) Recent advances in molecular epidemiology and detection of *Taylorella equigenitalis* associated with contagious equine metritis (CEM). *Vet. Microbiol.* 97, 111-122.
10. Katz, J.B. , Evans, L.E. , Hutto, D.L. , Schroeder-Tucker, L.C. , Carew, A.M. , Donahue, J.M. and Hirsh, D.C. (2000) Clinical, bacteriologic, serologic, and pathologic features of infections with atypical *Taylorella equigenitalis* in mares. *J. Am. Vet. Med. Assoc.* 216, 1945-1948.

11. Bleumink-Pluym, N.M.C. , Werdler, M.E.B. , Houwers, D.J. , Parlevliet, J.M. , Colenbrander, B. and van der Zeijst, B.A.M. (1994) Development and evaluation of PCR test for detection of *Taylorella equigenitalis* . *J. Clin. Microbiol.* 32, 893-896.
12. Duquesne, F. , Pronost, S. , Laugier, C. and Petry, S. (2007) Identification of *Taylorella equigenitalis* responsible for contagious equine metritis in equine genital swabs by direct polymerase chain reaction. *Res. Vet. Sci.* 82, 47-49.
13. Wakeley, P.R. , Errington, J. , Hannon, S. , Roest, H.I.J. , Carson, T. , Hunt, B. , Sawyer, J. and Heath, P. (2006) Development of a real time PCR for the detection of *Taylorella equigenitalis* directly from genital swabs and discrimination from *Taylorella asinigenitalis* . *Vet. Microbiol.* 118, 247-254.
14. Erdman, M.M. , Creekmore, L.H. , Fox, P.E. , Pelzel, A.M. , Porter-Spalding, B.A. , Aalsburg, A.M. , Cox, L.K. , Morningstar-Shaw, B.R. and Crom, R.L. (2011) Diagnostic and epidemiologic analysis of the 2008-2010 investigation of a multi-year outbreak of contagious equine metritis in the United States. *Prev. Vet. Med.* 101, 219-228.
15. Ricketts, S. , Crowhurst, J. , Newton, R. and Gibbons, N. (2012) Contagious equine metritis organism confirmed in Gloucestershire. *Vet. Rec.* 170, 398.
16. Department of Agriculture, Forestry and Fisheries. *South African Procedure Manual Screening of Stallions for Contagious Equine Metritis*  
<http://www.nda.agric.za/vetweb/Pamphlets&Information/Policy/CEM%20Screening%20manual-%20signed%2021%20May%202012.pdf>
17. Guthrie, A.J. , Howell, P.G. , Hedges, J.F. , Bosman, A.-M. , Balasuriya, U.B.R. , McCollum, W.H. , Timoney, P.J. and MacClachlan, N.J. (2003) Lateral transmission of equine arteritis virus among Lipizzaner stallions in South Africa. *Equine Vet. J.* 35, 596-600.
18. Directorate Animal Health. *Procedural Manual for the Confirmation of, Diagnosis and Treatment of Positive Cases of Contagious Equine Metritis*, 13 April 2011, updated October 2012
19. OIE. *OIE Manual of Diagnostic Tests and Vaccines for Terrestrial Animals*, Chapter 2.5.2, Contagious Equine Metritis version adopted 20/10/2011  
[http://www.oie.int/fileadmin/Home/eng/Health\\_standards/tahm/2.05.02\\_CEM.pdf](http://www.oie.int/fileadmin/Home/eng/Health_standards/tahm/2.05.02_CEM.pdf).
20. Olivieri, B.T. , Love, B.C. , Rezabek, G.B. , Lamm, C.G. , Varner, D.D. , Payton, M.E. and Holyoak, G.R. (2011) Effect of antibiotic-containing extenders on *Taylorella equigenitalis* contaminated semen. *J. Equine. Vet. Sci.* 31, 655-660.
21. May, C.E. , Schulman, M.L. , Keys, B. and Guthrie, A.G. (2013) The distribution of carrier status of *Taylorella equigenitalis* in stallions and exposed mares in South Africa. *Clin. Theriogenology* 5, 398.
22. Zdovc, I. , Ocepek, M. , Gruntar, I. , Pate, M. , Klobučar, I. and Krt, B. (2005) Prevalence of *T. equigenitalis* infection in stallions in Slovenia: bacteriology compared with PCR examination. *Equine Vet. J.* 37, 217-221.

## Supplementary Material

**Supplementary Item 1:** The identity, import status, breeding history, association with the index property and qPCR and bacterial culture test results of the *T. equigenitalis*-positive horses (n = 39) identified during the initial outbreak identification, the subsequent National screening programme and the traceback of in-contact horses.

Horse						Testing	
Identity	Sex M/F	Breed	Import Y/N	Bred Y/N	Index property Y/N	qPCR test (Ct)	Bacterial culture result +/-
Initial outbreak identification							
CEM_2011_01_01	M	W	Y	Y	Y	21.8	+
CEM_2011_01_02	F	T	N	Y	Y	ND	+
CEM_2011_02_03	M	W	N	Y	Y <sup>s</sup>	27.5	+
CEM_2011_02_04	M	W	N	N	N	ND	+
Total						4/4	4/4
National screening programme							
CEM_2011_03_05	M	W	Y	Y	Y <sup>s</sup>	17.6	+
CEM_2011_04_06	M	C	Y	Y	Y <sup>s</sup>	35.1	+
CEM_2011_05_07	M	W	Y	Y	Y	23.1	+
CEM_2011_06_08	M	L	N	Y	Y	24.2	+
CEM_2011_07_09	M	W	Y	Y	Y	23.8	+
CEM_2011_08_10	M	S	Y	Y	Y <sup>s</sup>	30.9	+
CEM_2011_10_35	M	A	Y	N	N	20.9	+
CEM_2011_11_36	M	W	Y	Y	Y	19.5	+
CEM_2011_12_37	M	W	Y	Y	Y <sup>s</sup>	17.9	+
Total						9/9	9/9
Traceback of in-contact horses							
CEM_2011_09_11	M	L	N	Y	Y	19.5	-
CEM_2011_09_12	M	L	N	N	N	18.5	+
CEM_2011_09_13	M	L	N	N	N	22.4	+
CEM_2011_09_14	M	L	N	N	N	21.9	+
CEM_2011_09_15	M	L	N	N	N	21.1	-
CEM_2011_09_16	M	L	Y	N	N	15.4	+
CEM_2011_09_17	M	L	N	N	N	23.6	-
CEM_2011_09_18	M	L	N	N	N	16.8	+
CEM_2011_09_19	M	L	N	Y	N	17.4	+
CEM_2011_09_20	M	L	N	Y	Y	21.2	-
CEM_2011_09_21	M	L	N	N	N	18.7	+
CEM_2011_09_22	M	L	N	Y	N	19.7	-
CEM_2011_09_23	M	L	N	N	N	21.4	+
CEM_2011_09_24	M	L	N	N	N	20.8	-
CEM_2011_09_25	M	L	N	Y	N	22.8	-
CEM_2011_09_26	M	L	N	Y	Y	25.3	+
CEM_2011_09_27	M	L	N	N	N	18.9	+
CEM_2011_09_28	M	L	N	Y	N	33.2	-
CEM_2011_09_29	M	L	N	Y	N	21.3	-
CEM_2011_09_30	M	L	N	Y	N	28.2	+
CEM_2011_09_31	M	L	N	Y	Y	34.4	+
CEM_2011_09_32	M	L	N	N	N	22.4	+
CEM_2011_09_33	M	L	N	N	N	21.4	+
CEM_2011_09_34	M	L	N	N	N	29.4	-
CEM_2011_13_38	F	T	N	Y	N	28.6	-
CEM_2011_08_39	F	W	N	N	N	24.5	+
Total						26/26	15/26

Ct – Cycle threshold; <sup>s</sup>= stallions present on the index property concurrent with index stallion; A, Andalusian; S, Selle Francais; C, Connemara; L, Lipizzaner; T, Thoroughbred; W, Warmblood; ND – not done; + positive; - negative