

SIMULTANEOUS INCREASING OF THERMAL CONVERSION EFFICIENCY AND BMEP WHILE REDUCING EMISSIONS

Victor GHEORGHIU*
Department of Mechanical Engineering,
Hamburg University of Applied Sciences, Germany,
E-mail: victor.gheorghiu@haw-hamburg.de

ABSTRACT

The Downsizing of internal combustion engines (**ICE**) is already recognized as a very suitable method for the concurrent enhancement of the indicated fuel conversion efficiency (**IFCE**) and the break mean effective pressure (**BMEP**) while also decreasing the CO₂ and NO_x emissions [1], [2].

The Ultra-Downsizing concept was introduced in [3] as a still higher development stage of ICE and implemented by means of real Atkinson cycles, using asymmetrical crank mechanisms, combined with a very intensive multistage high-pressure turbocharging with intensive intercooling. This allows an increase of ICE performance while keeping the thermal and mechanical strain strength of engine components within the current usual limits.

The investigations from [3] were carried out using the simulation tool BOOST (AVL Co). The three-stage turbocharging with intensive intercooling used in this process and the release of heat during combustion are controlled by numerous parameters. As a consequence, it is very difficult to harmonize them in order to optimize concurrently IFCE, BMEP and emissions. For this reason, the ideal **V,p,T**-model presented in [4] has been revised, improved and adapted to better meet the BOOST simulations. With help of this new, ideal **V,p,T**-model, it is possible to evaluate adequately the potential for improving the performance of Ultra-Downsizing.

INTRODUCTION

ICE downsizing is the simultaneous reduction of the displaced volume (usually by reducing the number of cylinders) while increasing the indicated mean pressure (**IMEP**) by means of turbocharging [1], [2]. This allows the preservation of power and torque performance while decreasing engine size. The result is that a) mechanical and thermal losses are reduced, b) the engine becomes lighter, leading to a drop in the overall weight of the vehicle, and c) the engine operates for a longer period of time within its optimum fuel consumption zone. The advantages offered by a) and b) hold true even for ICEs used in hybrid propulsion systems, while the advantage c) is already a feature of the full-hybrid vehicles.

The level of downsizing determines the strength of thermal and mechanical strains of the engine components. In order to avoid exceeding the usual limits, one can reduce either the boost pressure or the volumetric compression ratio (**VCR**) accordingly. However, this prevents one from reaching the full potential of downsizing, while the IFCE and IMEP remain at a low level.

The current ICEs have symmetrical (i.e. classical) crank mechanisms (i.e. with compression and expansion strokes of equal length) and follow the Seiliger (i.e. classical) thermodynamical cycles. Implementing real Atkinson cycles require unequal strokes with a shorter compression stroke, which leads to a higher IFCE [3]. Atkinson cycles have been used so far mostly with symmetrical crank mechanisms, where the intake valves are closed very late in the cycle [4]. Thus, a part of the charge sucked into the cylinder is pushed back into the intake pipes and the effective compression stroke is decreased. This quasi implementation of Atkinson cycles shows no noticeable improvements of the IFCE and, hence, it will not be discussed in the course of this paper (see [4] for details).

Real Atkinson cycles can be implemented only with the help of asymmetrical crank mechanisms. This allows to use concurrent very high boost pressures (to increase the IMEP) and higher VCR (to enhance the IFCE) and to set them much more independently of each other compared to Seiliger cycles [3], [4]. Because an important part of the fresh charge compression takes place beyond the cylinder, the high compressed fresh charge can be cooled intensively before it is sucked into the cylinder. The moderate compression occurring inside the cylinder (i.e. with relative lower VCR) leads to lower temperature peaks during the combustion process and, consequently, to fewer NO_x emissions.

This approach has already been shown to work in several previous theoretical investigations based on the ideal Seiliger and Atkinson cycles [4]. These investigations did not take into consideration the effect of heat exchange and frictional losses on the cycle in order to make it easier to check the solution and to draw a comparison between the Seiliger and Atkinson cycles. The IFCE and IMEP results achieved by using this method

are therefore unrealistically high and serve only as a general indication [4].

The paper [3] extends the previous investigations from [4] to real Atkinson cycles by using the simulation tool BOOST (AVL Co). This tool allows to take into consideration the true geometrical sizes of the engine components (cylinder, valves, channels, pipes, manifolds, turbocharger, intercooler, silencer etc.) and the losses caused by friction and heat transfer along the intake and exhaust gas pipes. In addition, the power balance of turbochargers determines the actual boost pressure level of the engine.

The turbochargers (TC) are modeled for these investigations in a simple manner, which describes the expansion process in the turbines (Tx) by means of their discharge coefficients. The air compaction in the compressors occurs up to a maximum pressure ratio, which depends on the available turbine output. To be able to simulate cycles featuring very high boost pressures, three intercooled TC are placed in line (three-stage turbocharging, see Fig. 1).

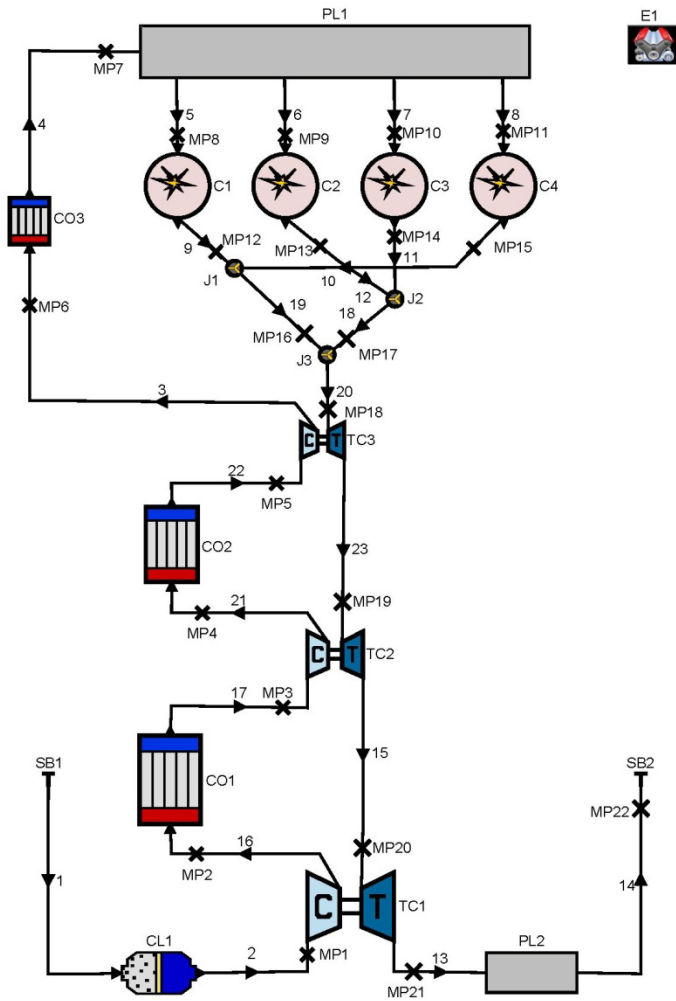

Figure 1 BOOST Model of a four cylinder TC engine

Simple number denote pipes, Cx = cylinder, COx = cooler, TCx = turbochargers, PLx = plenum, Jx = junctions, CLx = cleaner, SBx = system boundaries, Ex = engine and MPx = measuring points

The asymmetrical crank mechanism used here can realize the classical piston displacements for the Seiliger as well as for the Atkinson cycles with various asymmetries between the compression and expansion strokes. It can also enable the variation of VCR (see. Fig. 2).

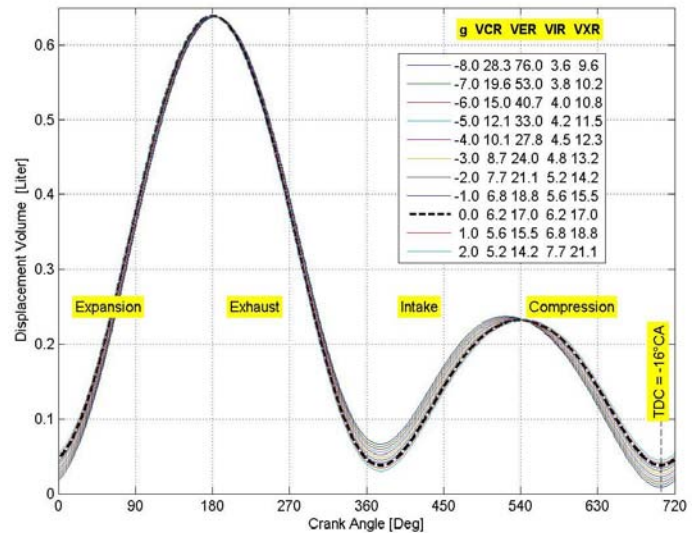

Figure 2 Relative Displacements of the used Asymmetrical Crank Mechanism

The Atkinson (Atk) cycles are implemented here by varying the parameter g of the crank mechanism used. The dashed curve represents the null position where a) the expansion and exhaust and b) the intake and compression strokes are identical. VCR, VER, VIR and VXR mean the volumetric compression, expansion, intake and exhaust ratios.

In the case of supercharged ICE, the number of parameters which influence the IFCE and BMEP is very high. As a consequence, the effort to achieve combinations of parameters which maximize the performances of the **real** (by BOOST) ICE cycle becomes much more difficult. For these reasons, **ideal** models of the **V,p,T-Seiliger** and **-Atkinson** cycles have been developed for this purpose (see [4] and Appendix).

Modeling by means of V,p,T-cycles has the advantage of allowing users to generate ideal ICE cycles which model more closely the real cycles than the classic ideal V- and V,p-cycles by observing their mechanical (pressure) and thermal limits. A simple V-cycle (Otto cycle), where the heat is released only in an isochoric manner (i.e. by constant volume), generates unrealistically high levels of maximum pressure and temperature on the cycle. The attempt to limit the maximum pressure level leads to the classic V,p-cycle [5], [6], where the heat is released in an isochoric and isobaric (constant pressure) manner. The V,p-cycles (i.e. classic Seiliger cycles) leads, for example, to very high temperature levels in the case of fully loaded supercharged engines. These levels are completely unrealistic.

In the ideal V,p,T-cycle the heat is partially released isochorically on the 2 – 3v change of states, isobarically on 3v – 3p and isothermally on 3p – 3 (see yellow states noted in bottom part of Fig. 3). The amounts of heat released isochorically and isobarically depend on the targets for maxi-

imum pressure and temperature on the cycle. The theoretical background of this new V,p,T-cycle is presented in detail in the Appendix.

GOALS OF THESE INVESTIGATIONS

To raise the IFCE, most of the working gas expansion should occur within the cylinder. If, however, the expansion process occurs entirely within the cylinder (ideally, a full expansion occurs up to the ambient pressure), no additional boost pressure can be generated.

In order to increase the expansion part within the cylinder, the crank mechanism must provide a higher VER, which makes a long expansion stroke (and, therefore, an engine with a long piston displacement) necessary. However, that leads to high IFCE, but quite low indicated specific power (kW/L) and IMEP of the engine.

In order to increase both the IFCE and the IMEP, the engine must be turbocharged and the ratio between the expansions within the cylinder and within the turbines (i.e. between internal and external expansion) must be optimized. To be able to optimize this ratio (i.e. between internal and external expansions) regardless of VCR, an asymmetrical crank mechanism is required by the real Atkinson cycles.

The goal of [3] and also of this paper is to look for the optimum ratio between internal and external expansion, which allows us to increase the IFCE and BMEP while lowering the CO₂ and NO_x emissions.

The special goal of this paper is to evaluate the maximum improving potential of the Ultra-Downsizing performances of the cycles simulated in [3] by means of the BOOST.

SIMULATION SETTINGS

The simulations of the piston displacements presented in Fig. 2 are carried out using the BOOST model from Fig. 1 and V,p,T ideal model (see Appendix). The parameters and the performance of seven cycles are shown in following figures. Many parameters from all cycles are kept identical in order to make comparison easier.

Most parameters of the BOOST model are selected for a hypothetical engine and are kept unchanged for all simulations. This includes all geometrical dimensions (with the exception of the crank mechanism), valve timing, wall temperatures (300 K) and heat transfer coefficients (Re-analogy) of the pipes, as well as efficiencies and pressure losses of the intercoolers (target efficiency = 0.75, target pressure drop = 5 kPa) and friction coefficients in the pipes (0.019). Likewise, the efficiency of the turbochargers (compressor efficiency = 0.75, turbocharger overall efficiency = 0.5), as well as the blow by gap size of the cylinder, frictional characteristic curve of the engine and AFR.

A simple Vibe function is selected in all BOOST simulations in order to model the combustion process. The different positions of the TDC in the Atkinson cycles are compensated by choosing a suitable start of combustion (SOC) so that combustion begins in all cycles uniformly at 15°CA before TDC.

The various simulation parameters are selected with the purpose of obtaining roughly the same maximum cylinder pressure in all cycles. In order to reach this state, the discharge coefficients of the three turbines in the BOOST simulations are

varied according to a) the influence of backpressure behind the cylinder (e.g., at the measuring point MP12 for cylinder 1; see Fig. 1) and to b) the boost pressure (e.g., at MP8 for cylinder 1). In order to reach approximately the same expansion rate in all three turbines, their discharge coefficients are set at the same level and compensated with the cross section ratios of the turbine output pipes. The discharge coefficient of the third turbine μ_{T3} is the only parameter which was adapted for each cycle to meet the cylinder peak pressure limit, since this sets the other two discharge coefficients μ_{T2} and μ_{T1} .

In the ideal V,p,T model (see Appendix), the thermal properties of the working fluid (κ_c for unburned and κ_e for burned parts) are kept constant throughout the cycle. The entire fuel mass is added to the cylinder gas mass in the state 3v of the cycle. The mass contribution of the exhaust rest gas part is also taken into consideration. The available heat (from fuel combustion) decreases by the amount of heat transferred to cylinder wall. In this case, compression, combustion and expansion can be treated adiabatically. The backpressure behind the cylinder p_T (equivalent of the MP12 from the BOOST model) is computed by means of energy balance at the turbocharger ($W_{CuC} = W_{TTu}$).

COMPARISON OF V,P,T AND BOOST SIMULATION RESULTS

In order to be able to compare the simulation results following parameter are carry over from the BOOST to V,p,T-model: p_C , T_C , p_{max} , T_{max} , m_1 , m_f , γ , κ_c , κ_e , Q_{wall} (see Appendix for their meaning).

The diagrams of cylinder pressure over displacement volume from Fig. 3 show a relative a good concordance for the high pressure part of the cycles. The heat release and heat transfer to cylinder wall are responsible for most of the differences. The V,p,T model features an optimal heat release, i.e. the maximum achievable isochorically and isobarically parts for reaching the target values for maximum pressure and temperature on the cycle.

The gas exchange and turbocharging processes used in the V,p,T model are also optimal.

The parameter and performances of the BOOST and V,p,T cycle simulations are shown in Fig. 4.

The IFCE values of the V,p,T model follow the upward movement of VCR and VER values (the VCR and VER values of each \mathbf{g} position of the crank shaft are presented in the legend of Fig. 2) principally because of the optimized heat release. The areas of ψ , $1-\psi-\theta$ and θ from the diagram of heat release rates from Fig. 4 explain this tendency.

The residual gas mass (i.e. rest exhaust gas rate per cycle γ) in the V,p,T case is the result of this ideal model. However, when initializing the V,p,T simulations, the model uses the values from BOOST simulations (without iterations).

The differences between the pressure and temperature behind cylinder (i.e. in MP12 of the BOOST model, see Fig. 1) show the maximum potential of turbocharging in these operating points.

The maxima of the cylinder pressure and temperature are kept identical in the BOOST and V,p,T simulations.

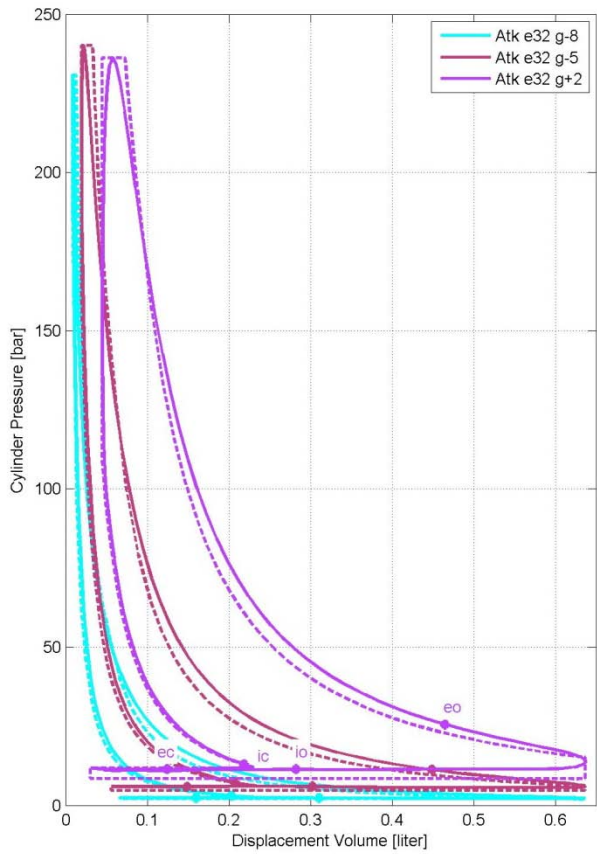

Figure 3 Cylinder pressure (logarithmic bottom) - displacement volume (p,V) diagrams for Boost (with valves timing) and V,p,T (dashed curves) for three chosen Cycles
 Legend: eo = exhaust open; ec = exhaust close; io = intake open; ic = intake close

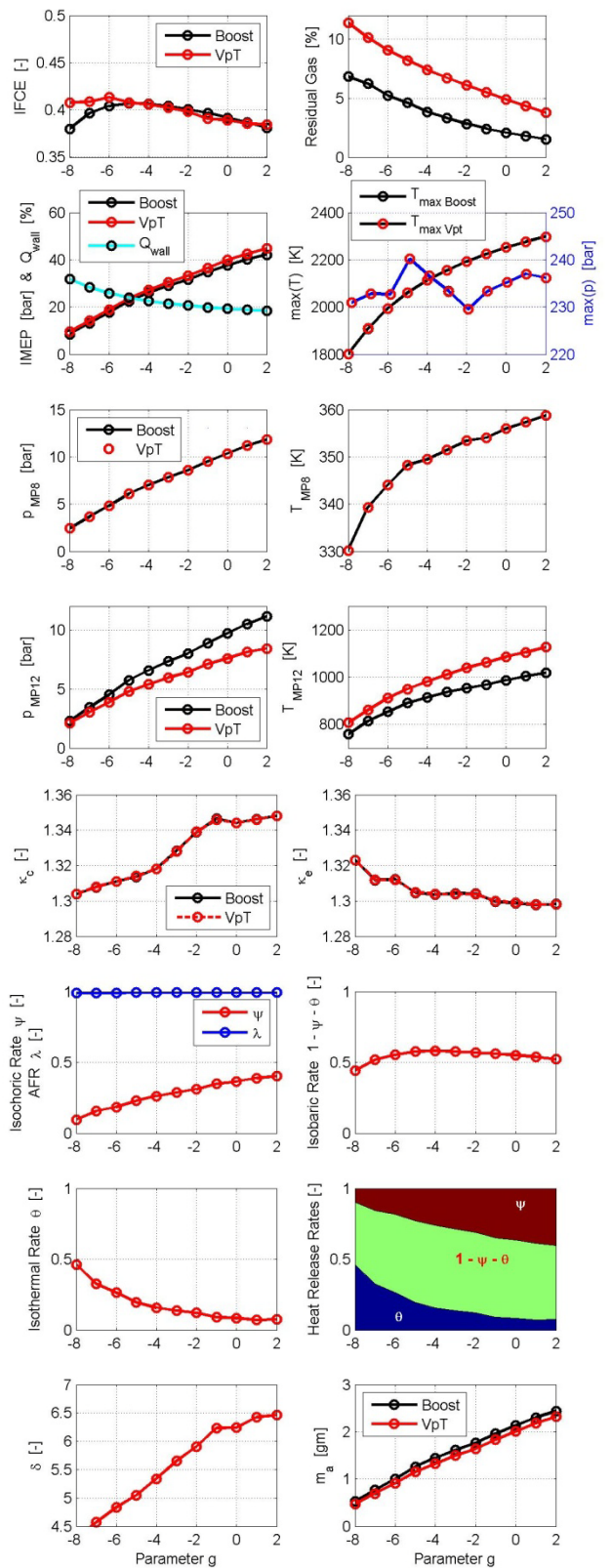

Figure 4 Parameters and performances of BOOST and V,p,T simulations

COMPARISON OF V,p,T WITH CONSTANT MAXIMAL TEMPERATURE AND BOOST SIMULATION RESULTS

Because the maximum temperatures vary considerably in the BOOST simulations (see Fig. 4 and 5), it is important to compare these performances to those from the V,p,T simulations with steady maximal temperature on the cycle. This comparison should be able to show the improved potential of IFCE performance for the BOOST (i.e. real cycle) simulations.

In these V,p,T simulations, the maxima of cylinder pressure and temperature on the cycle are 230 bar and 2100 K (see Fig. 5 and 7). Since the T_{max} value is constant, a) the isentropic exponents on compression and expansion and b) the heat transfer to the cylinder wall Q_{wall} (20% of Q_{rel}) are also kept constant in all simulated cycles (see Fig. 7).

The temperature curves from Fig. 7 show big differences between the BOOST and V,p,T simulations. These differences - in addition to the different T_{max} values - are caused by different values for heat release rates, heat transfers to cylinder wall, thermal capacities etc.

The variation of the gas mass during the cycle is shown in Fig. 6. The correlation between the BOOST and V,p,T simulations are in this case suitable.

The IFCE values in the V,p,T are much higher when both the VCR and VER increase (i.e. to small values of the crank mechanism parameter g , see Fig. 2 and 7) because of the optimized heat release. The areas of ψ , $1-\psi-\theta$ and θ from the heat release rates diagram of Fig. 7 explain this tendency.

CONCLUSION

The implementation of real Atkinson cycles for turbocharged engines using asymmetrical crank mechanisms offers the following advantages: a) relatively high IMEP, b) higher IFCE, leading to fewer CO₂ emissions and c) lower temperatures during the combustion stage, leading to fewer NO_x emissions.

In order to achieve this, the engine requires (in addition to variable valves timing etc.) the use of turbocharger systems with at least two stages, which must be adapted accordingly and controlled with the help of bypasses to maximize their performance. Their optimizing is as a result very time expensive.

The comparisons between V,p,T and BOOST simulations from this paper show that this ideal V,p,T model can simulate a real model (in this case BOOST) relative accurate and predict correctly the upper limit of cycle performances under the given engine operating conditions.

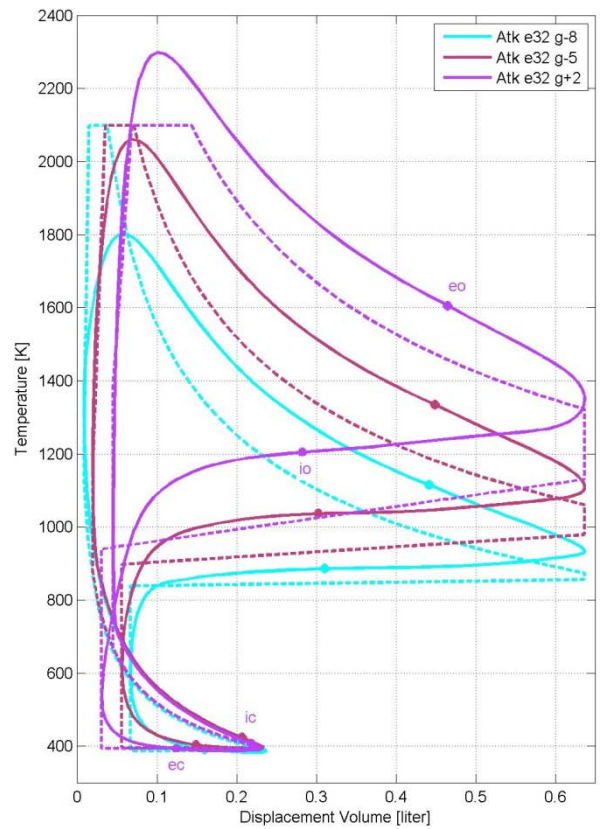

Figure 5 Cylinder temperature - displacement volume (T,V) diagrams with constant T_{max} in V,p,T simulations

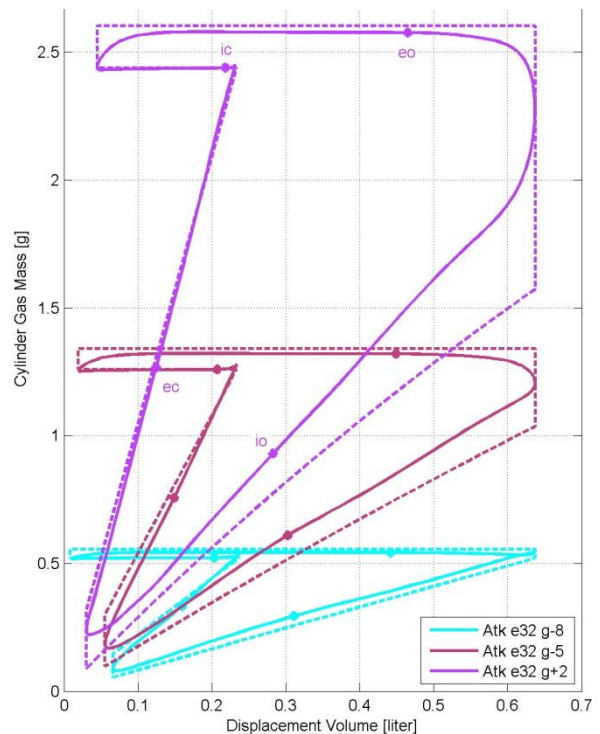

Figure 6 Gas mass - displacement volume (m,V) diagrams with constant T_{max} in V,p,T simulations

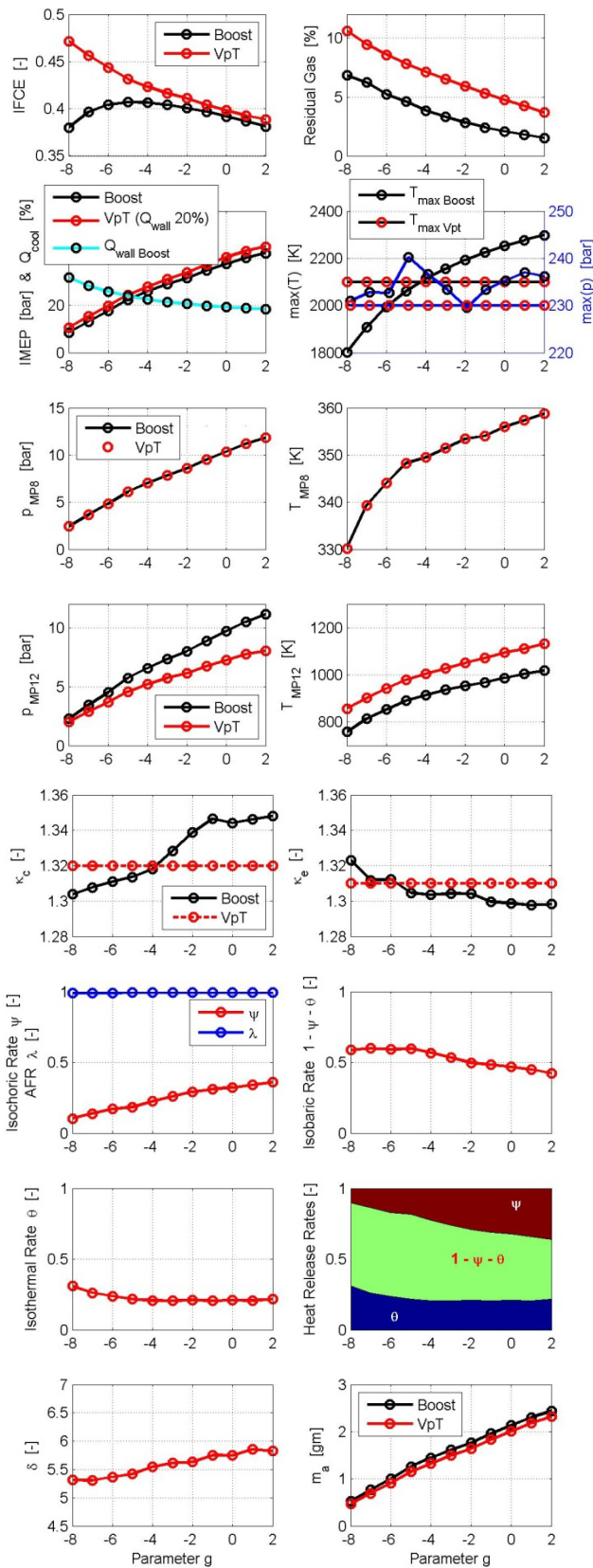

Figure 7 Parameters and performances of BOOST and V,p,T simulations

REFERENCES

- [1] Weinowski, R., Sehr A., Wedowski, S., Heuer, S., Hamm, T., Tiemann, C., *Future downsizing of S.I. engines - potentials and limits of 2- and 3-cylinder concepts*, Vienna Motor Symposium 2009
- [2] Korte, V., Lumsden, G., Fraser, N., Hall, J., *30% higher efficiency at 50% less displacement*, MTZ 2010
- [3] Gheorghiu, V., *Ultra-Downsizing of Internal Combustion Engines: Simultaneous Increasing of Thermal Conversion Efficiency and Power while reducing emissions*, HEFAT 2011, Mauritius
- [4] Gheorghiu, V., *CO₂-Emission Reduction by Means of Enhancing the Thermal Conversion Efficiency of ICE Cycles*, HEFAT 2010, Antalya, Turkey
- [5] Heywood, JB, *Internal Combustion Engine Fundamentals*, MacGraw-Hill Book Company, 1988
- [6] Pischinger, A., Kraßnig, G., Taucar, G., & Sams, Th., *Thermodynamic of Internal Combustion Engines* (German), Springer-Verlag, Wien New York, 1989

APPENDIX / DEFINITIONS

Symbol	Meaning	Units
$\varepsilon_c = \frac{V_1}{V_2} = \frac{V_{in}}{V_c}$	volumetric compression ratio	-
$\varepsilon_e = \frac{V_5}{V_2} = \frac{V_e}{V_c}$	volumetric expansion ratio	-
$\varepsilon_i = \frac{V_1}{V_7} = \frac{V_{in}}{V_{out}}$	volumetric intake ratio	-
$\varepsilon_x = \frac{V_5}{V_6} = \frac{V_e}{V_{out}}$	volumetric exhaust ratio	-
$V_c = V_2 = V_{3v}$	cylinder volume at end of compression	m ³
$V_e = V_4 = V_5 = V_{max}$	cylinder volume at end of expansion	m ³
$V_{out} = V_6 = V_7$	cylinder volume at end of emptying	m ³
$V_{disp} = V_{max} \cdot \left(1 - \min\left(\frac{1}{\varepsilon_e}, \frac{1}{\varepsilon_x}\right)\right)$	cylinder displacement	m ³
$p_{max} = p_{3v} = p_{3p}$	maximal pressure on cycle	Pa
$T_{max} = T_{3p} = T_3$	maximal temperature on cycle	K
$p_1 = p_c$	cylinder pressure in state 1	Pa
m_1	cylinder gas mass in state 1	kg
$T_1 = \frac{p_1 \cdot V_1}{m_1 \cdot R}$	cylinder temperature in state 1	K
$V_1 = V_{max} \cdot \frac{\varepsilon_c}{\varepsilon_e}$	cylinder volume in state 1	m ³
$m_a = m_1 \cdot \frac{\varepsilon_x - 1}{\varepsilon_x}$	aspirated charge mass per cycle	kg
$m_{max} = m_1 + m_f$	maximal gas mas on cycle	kg
m_f	fuel mass per cycle	kg
γ	exhaust rest gase rate per cycle	-
$\lambda = \frac{m_1 \cdot (1 - \gamma)}{L_{st} \cdot m_f}$	air-exces ratio (AFR)	-
L_{st}	stoichiometric air requirement ratio	$\frac{kg}{kg}$
κ_c, κ_e	isentropic exponents and	-
$c_{p,c}, c_{v,c}$	isobaric (p) & isochoric (v) specific heat capacities on compression (c)	$\frac{J}{kg \cdot K}$
$c_{p,e}, c_{v,e}$	resp. expansion (e)	$\frac{J}{kg \cdot K}$
R	ideal gas constant	$\frac{J}{kg \cdot K}$
H_u, H_{vap}	fuel lower heating & vaporisation heat values	$\frac{J}{kg}$

APPENDIX / FORMULA

Formula for the ideal V,p,T-model

$$\delta = \frac{H_u \cdot \eta_v + \frac{Q_{wall}}{m_f}}{\left(\frac{\lambda \cdot L_{st}}{1 - \gamma} \cdot \frac{\varepsilon_x}{\varepsilon_x - 1} + 1\right) \cdot c_{v,c} \cdot T_1}$$

$$\psi = \frac{\kappa_c - 1}{\delta \cdot \varepsilon_c \cdot p_c} \cdot \frac{m_1}{m_{max}} \cdot \left(\frac{p_{max}}{\kappa_e - 1} - \frac{p_c}{\kappa_c - 1} \cdot \varepsilon_c^{\kappa_c} + \frac{\varepsilon_e}{V_{max}} \cdot Q_{vap}\right)$$

$$m_2 = m_1 \quad p_2 = p_1 \cdot \varepsilon_c^{\kappa_c} \quad V_2 = \frac{V_1}{\varepsilon_c} \quad T_2 = T_1 \cdot \varepsilon_c^{\kappa_c - 1}$$

$$m_{3v} = m_{max} = m_1 \cdot \left(1 + \frac{1 - \gamma}{\lambda \cdot L_{st}} \cdot \frac{\varepsilon_x - 1}{\varepsilon_x}\right)$$

$$p_{3v} = p_{max} \quad V_{3v} = V_2 \quad T_{3v} = \frac{m_1}{m_{max}} \cdot \frac{p_{max}}{p_c} \cdot \frac{T_1}{\varepsilon_c}$$

$$\theta = 1 - \psi - \frac{\kappa_e \cdot (\kappa_c - 1)}{(\kappa_e - 1) \cdot \delta} \cdot \left(\frac{T_{max}}{T_1} - \frac{m_1}{m_{max}} \cdot \frac{p_{max}}{p_c} \cdot \frac{1}{\varepsilon_c}\right)$$

$$m_{3p} = m_{max} \quad V_{3p} = V_{3v} \cdot \frac{T_{max}}{T_{3v}} \quad T_{3p} = T_3 = T_{max}$$

$$m_3 = m_{max} \quad V_3 = \frac{m_{max} \cdot R \cdot T_{max}}{p_{max}} \cdot \exp\left[\frac{\theta \cdot \delta \cdot T_1}{(\kappa_c - 1) \cdot T_{max}}\right]$$

$$m_4 = m_{max} \quad V_4 = V_{max} \quad p_4 = p_3 \cdot \left(\frac{V_3}{V_4}\right)^{\kappa_e} \quad T_4 = T_3 \cdot \left(\frac{V_3}{V_4}\right)^{\kappa_e - 1}$$

$$W_{CuC} = c_{p,c} \cdot \frac{m_a \cdot T_u}{\eta_{sC}} \cdot \left[\left(\frac{p_c}{p_u}\right)^{\frac{\kappa_c - 1}{\kappa_c}} - 1\right]$$

$$W_{TTu} = \eta_{sT} \cdot (m_a + m_f) \cdot c_{p,e} \cdot T_T \cdot \left[1 - \left(\frac{p_u}{p_T}\right)^{\frac{\kappa_e - 1}{\kappa_e}}\right]$$

$$W_{CuC} = W_{TTu} \quad k_1 = \eta_{TC} \cdot \frac{1 - \gamma + \lambda \cdot L_{st}}{\lambda \cdot L_{st}} \cdot \frac{\kappa_e}{\kappa_e - 1} \cdot \frac{\kappa_c - 1}{\kappa_c} \cdot \frac{1}{T_u}$$

$$p_T = p_4 \cdot \left[\left(\frac{p_u}{p_4}\right)^{\frac{\kappa_e - 1}{\kappa_e}} + \frac{1}{k_1 \cdot T_4} \cdot \left[\left(\frac{p_c}{p_u}\right)^{\frac{\kappa_c - 1}{\kappa_c}} - 1\right]\right]^{\frac{\kappa_e}{\kappa_e - 1}}$$

APPENDIX / DEFINITIONS

Symbol	Meaning	Units
$Q_{rel} = m_f \cdot H_u$	cylinder released heat	J
η_b	released fuel energy completeness	-
Q_{wall}	heat transfer to cylinder wall	J
$Q_{disp} = Q_{rel} \cdot \eta_b + Q_{wall}$	disposable heat on cycle	J
p_C	charge pressure after cooler	Pa
T_C	charge temperature after cooler	K
p_T	pressure before turbine	Pa
T_T	temperature before turbine	K
p_u	ambient pressure	Pa
$\delta = \frac{Q_{disp}}{m_{max} \cdot c_{v,c} \cdot T_1}$	relative released heat as measure of engine load	-
$Q_{disp.v}$	isochoric part of Q_{disp}	J
$\psi = \frac{Q_{disp.v}}{Q_{disp}}$	isochoric released heat fraction	-
$Q_{disp.t}$	isothermal part of Q_{disp}	J
$\theta = \frac{Q_{disp.t}}{Q_{disp}}$	isothermal released heat fraction	-
$1 - \psi - \theta = \frac{Q_{disp.p}}{Q_{disp}}$	isobaric released heat fraction	-
$Q_{disp.p}$	isobaric part of Q_{disp}	J
$\eta_i = \frac{-W_{cycle}}{Q_{rel}}$	indicated fuel conversion efficiency	-
W_{cycle}	work on the all cycle	J
$p_i = \frac{-W_{cycle}}{V_{disp}}$	indicated mean pressure IMEP	Pa
$\eta_{sC}, \eta_{sT}, \eta_{TC}$	isentropic efficiency of compressor, turbine and turbocharger	-
W_{TTu}	turbine work between p_T and p_u	J
W_{CuC}	compressor work between p_u and p_C	J

APPENDIX / FORMULA

$$\begin{aligned}
 T_5 &= T_4 \cdot \left(\frac{p_5}{p_4} \right)^{\frac{\kappa_e - 1}{\kappa_e}} & V_5 &= V_{max} & p_5 &= p_T \\
 p_6 &= p_5 & V_6 &= \frac{V_{max}}{\varepsilon_x} & T_6 &= 2 \cdot T_5 - T_4 \\
 m_6 &= \frac{p_6 \cdot V_6}{R \cdot T_6} & \gamma &= \frac{m_6}{m_1} \\
 W_{cycle} &= \frac{p_C \cdot V_{max}}{\kappa_c - 1} \cdot \frac{\varepsilon_c}{\varepsilon_e} \cdot \left(\varepsilon_c^{\kappa_c - 1} - 1 \right) + \frac{p_{max} \cdot V_{max}}{\varepsilon_e} \dots \\
 &+ (-m_{max}) \cdot R \cdot T_{max} - \theta \cdot \delta \cdot \frac{m_{max} \cdot R \cdot T_1}{\kappa_e - 1} \dots \\
 &+ \frac{m_{max} \cdot R \cdot T_{max}}{\kappa_e - 1} \cdot \left[\left(\frac{V_3}{V_{max}} \right)^{\kappa_e - 1} - 1 \right] \dots \\
 &+ p_T \cdot V_{max} \cdot \frac{\varepsilon_x - 1}{\varepsilon_x} - p_C \cdot V_{max} \cdot \left(\frac{\varepsilon_c}{\varepsilon_e} - \frac{1}{\varepsilon_x} \right)
 \end{aligned}$$

ABBREVIATIONS

AFR	Air-Fuel Ratio
BMEP	Break Mean Pressure
CA	Crank Angle
EOP	Engine Operating Point
ICE	Internal Combustion Engine
IFCE	Indicated Fuel Conversion Efficiency
IMEP	Indicated Mean Pressure
MPx	Measuring Point x in BOOST model
RE4T	Relative Energy for Turbo charging
SOC	Start of Combustion
TC	Turbocharger
Tx	Turbine x (here x = 1..3)
VCR	Volumetric Compression Ratio
VER	Volumetric Expansion Ratio
VIR	Volumetric Intake Ratio
VXR	Volumetric Exhaust Ratio
V,p,T	Model of an ideal cycle where the heat is partially released isochorically, isobarically and isothermally
eo	Exhaust Valve Open
ec	Exhaust Valve Close
io	Intake Valve Open
ic	Intake Valve Close
μ_{Tx}	Discharge Coefficient of Turbine x